

# FCC Test Report

Product Name	VoIP Phone
Model No.	UVP-Pro
FCC ID.	SWX-UVPPRO

Applicant	Ubiquiti Networks, Inc.
Address	12F, No. 105, Song Ren Rd., Sin Yi District, Taipei 110, Taiwan

Date of Receipt	Sep. 05, 2014
Issued Date	Nov. 14, 2014
Report No.	1490232R-RFUSP73V00
Report Version	V1.0



The test results relate only to the samples tested.

The test results shown in the test report are traceable to the national/international standard through the calibration report of the equipment and evaluated measurement uncertainty herein.

This report must not be used to claim product endorsement by TAF or any agency of the government.

The test report shall not be reproduced without the written approval of Quietek Corporation.

# Test Report

Issued Date: Nov. 14, 2014

Report No.: 1490232R-RFUSP73V00



Product Name	VoIP Phone
Applicant	Ubiquiti Networks, Inc.
Address	12F, No. 105, Song Ren Rd., Sin Yi District, Taipei 110, Taiwan
Manufacturer	Ubiquiti Networks, Inc.
Model No.	UVP-Pro
FCC ID.	SWX-UVPPRO
EUT Rated Voltage	DC 48V (Power by POE)
EUT Test Voltage	AC 120V/ 60Hz
Trade Name	UBIQUITI
Applicable Standard	FCC CFR Title 47 Part 15 Subpart C: 2014 ANSI C63.10: 2009
Test Result	Complied

Documented By : Rita Huang  
( Senior Adm. Specialist / Rita Huang )

Tested By : Benjamin Pan  
( Engineer / Benjamin Pan )

Approved By : Vincent Lin  
( Director / Vincent Lin )

TABLE OF CONTENTS

Description	Page
<b>1. GENERAL INFORMATION .....</b>	<b>5</b>
1.1. EUT Description.....	5
1.2. Operational Description.....	7
1.3. Tested System Details.....	8
1.4. Configuration of Tested System .....	8
1.5. EUT Exercise Software .....	8
1.6. Test Facility .....	9
<b>2. CONDUCTED EMISSION .....</b>	<b>10</b>
2.1. Test Equipment.....	10
2.2. Test Setup .....	10
2.3. Limits.....	11
2.4. Test Procedure .....	11
2.5. Uncertainty .....	11
2.6. Test Result of Conducted Emission.....	12
<b>3. PEAK POWER OUTPUT .....</b>	<b>14</b>
3.1. Test Equipment.....	14
3.2. Test Setup .....	14
3.3. Limit .....	14
3.4. Test Procedure .....	14
3.5. Uncertainty .....	14
3.6. Test Result of Peak Power Output.....	15
<b>4. RADIATED EMISSION .....</b>	<b>17</b>
4.1. Test Equipment.....	17
4.2. Test Setup .....	17
4.3. Limits.....	18
4.4. Test Procedure .....	19
4.5. Uncertainty .....	19
4.6. Test Result of Radiated Emission.....	20
<b>5. RF ANTENNA CONDUCTED TEST .....</b>	<b>28</b>
5.1. Test Equipment.....	28
5.2. Test Setup .....	28
5.3. Limits.....	28
5.4. Test Procedure .....	28
5.5. Uncertainty .....	28
5.6. Test Result of RF Antenna Conducted Test.....	29
<b>6. BAND EDGE .....</b>	<b>33</b>
6.1. Test Equipment.....	33
6.2. Test Setup .....	33
6.3. Limit .....	34
6.4. Test Procedure .....	34
6.5. Uncertainty .....	34

6.6.	Test Result of Band Edge .....	35
<b>7.</b>	<b>CHANNEL NUMBER.....</b>	<b>43</b>
7.1.	Test Equipment .....	43
7.2.	Test Setup .....	43
7.3.	Limit .....	43
7.4.	Test Procedure .....	43
7.5.	Uncertainty .....	43
7.6.	Test Result of Channel Number.....	44
<b>8.</b>	<b>CHANNEL SEPARATION.....</b>	<b>46</b>
8.1.	Test Equipment .....	46
8.2.	Test Setup .....	46
8.3.	Limit .....	46
8.4.	Test Procedure .....	46
8.5.	Uncertainty .....	46
8.6.	Test Result of Channel Separation.....	47
<b>9.</b>	<b>DWELL TIME.....</b>	<b>51</b>
9.1.	Test Equipment .....	51
9.2.	Test Setup .....	51
9.3.	Limit .....	51
9.4.	Test Procedure .....	51
9.5.	Uncertainty .....	51
9.6.	Test Result of Dwell Time .....	52
<b>10.</b>	<b>OCCUPIED BANDWIDTH .....</b>	<b>56</b>
10.1.	Test Equipment .....	56
10.2.	Test Setup .....	56
10.3.	Limits.....	56
10.4.	Test Procedure .....	56
10.5.	Uncertainty .....	56
10.6.	Test Result of Occupied Bandwidth .....	57
<b>11.</b>	<b>EMI REDUCTION METHOD DURING COMPLIANCE TESTING .....</b>	<b>63</b>

Attachment 1: EUT Test Photographs  
 Attachment 2: EUT Detailed Photographs

**1. GENERAL INFORMATION**

**1.1. EUT Description**

Product Name	VoIP Phone
Trade Name	UBIQUITI
Model No.	UVP-Pro
FCC ID.	SWX-UVPPRO
Frequency Range	2402 – 2480MHz
Channel Number	79
Type of Modulation	FHSS: GFSK(1Mbps) / $\pi$ /4DQPSK(2Mbps) / 8DPSK(3Mbps)
Antenna Type	Chip Antenna
Channel Control	Auto
Antenna Gain	Refer to the table “Antenna List”
Power Adapter	MFR: Ubiquiti, M/N: GP-B480-050G Input: 100-240V, 50/60Hz MAX 0.75A Output: 48V ---0.5A

**Antenna List**

No.	Manufacturer	Antenna Type	Peak Gain
1	TDK	Chip Antenna	2.27 dBi for 2.4 GHz

Note:

The antenna of EUT is conform to FCC 15.203.

Center Frequency of Each Channel:

Channel	Frequency	Channel	Frequency	Channel	Frequency	Channel	Frequency
Channel 00:	2402 MHz	Channel 20:	2422 MHz	Channel 40:	2442 MHz	Channel 60:	2462 MHz
Channel 01:	2403 MHz	Channel 21:	2423 MHz	Channel 41:	2443 MHz	Channel 61:	2463 MHz
Channel 02:	2404 MHz	Channel 22:	2424 MHz	Channel 42:	2444 MHz	Channel 62:	2464 MHz
Channel 03:	2405 MHz	Channel 23:	2425 MHz	Channel 43:	2445 MHz	Channel 63:	2465 MHz
Channel 04:	2406 MHz	Channel 24:	2426 MHz	Channel 44:	2446 MHz	Channel 64:	2466 MHz
Channel 05:	2407 MHz	Channel 25:	2427 MHz	Channel 45:	2447 MHz	Channel 65:	2467 MHz
Channel 06:	2408 MHz	Channel 26:	2428 MHz	Channel 46:	2448 MHz	Channel 66:	2468 MHz
Channel 07:	2409 MHz	Channel 27:	2429 MHz	Channel 47:	2449 MHz	Channel 67:	2469 MHz
Channel 08:	2410 MHz	Channel 28:	2430 MHz	Channel 48:	2450 MHz	Channel 68:	2470 MHz
Channel 09:	2411 MHz	Channel 29:	2431 MHz	Channel 49:	2451 MHz	Channel 69:	2471 MHz
Channel 10:	2412 MHz	Channel 30:	2432 MHz	Channel 50:	2452 MHz	Channel 70:	2472 MHz
Channel 11:	2413 MHz	Channel 31:	2433 MHz	Channel 51:	2453 MHz	Channel 71:	2473 MHz
Channel 12:	2414 MHz	Channel 32:	2434 MHz	Channel 52:	2454 MHz	Channel 72:	2474 MHz
Channel 13:	2415 MHz	Channel 33:	2435 MHz	Channel 53:	2455 MHz	Channel 73:	2475 MHz
Channel 14:	2416 MHz	Channel 34:	2436 MHz	Channel 54:	2456 MHz	Channel 74:	2476 MHz
Channel 15:	2417 MHz	Channel 35:	2437 MHz	Channel 55:	2457 MHz	Channel 75:	2477 MHz
Channel 16:	2418 MHz	Channel 36:	2438 MHz	Channel 56:	2458 MHz	Channel 76:	2478 MHz
Channel 17:	2419 MHz	Channel 37:	2439 MHz	Channel 57:	2459 MHz	Channel 77:	2479 MHz
Channel 18:	2420 MHz	Channel 38:	2440 MHz	Channel 58:	2460 MHz	Channel 78:	2480 MHz
Channel 19:	2421 MHz	Channel 39:	2441 MHz	Channel 59:	2461 MHz		

Note:

1. The EUT is a VoIP Phone with a built-in WLAN and Bluetooth transceiver, this report for Bluetooth.
2. These tests were conducted on a sample for the purpose of demonstrating compliance of Bluetooth transmitter with Part 15 Subpart C Paragraph 15.247 for spread spectrum devices.
3. Regarding to the operation frequency, the lowest, middle and highest frequency are selected to perform the test.
4. Bluetooth operation was evaluated at both 1Mb/s and 3Mb/s data rates. 2Mb/s data rate was found, through pre-testing, to produce emissions similar to those for 3Mb/s.

Test Mode	Mode 1: Transmit - 1Mbps (GFSK) Mode 2: Transmit - 3Mbps (8DPSK)
-----------	---

**1.3. Tested System Details**

The types for all equipment, plus descriptions of all cables used in the tested system (including inserted cards) are:

	Product	Manufacturer	Model No.	Serial No.	Power Cord
1	Notebook PC	DELL	PP18L	36119001664	Non-Shielded, 0.8m
2	POE	Ubiquiti	GP-B480-050	N/A	N/A
3	Earphone	Dr.AV	CD-806B	N/A	N/A

Signal Cable Type	Signal cable Description
A	USB Cable Shielded, 1.0m, with one ferrite core bonded.
B	RJ45 Cable Non-Shielded, 1.0m
C	Earphone Cable Non-Shielded, 1.0m
D	RJ45 Cable Non-Shielded, 2.0m, two PCS.

**1.4. Configuration of Tested System**

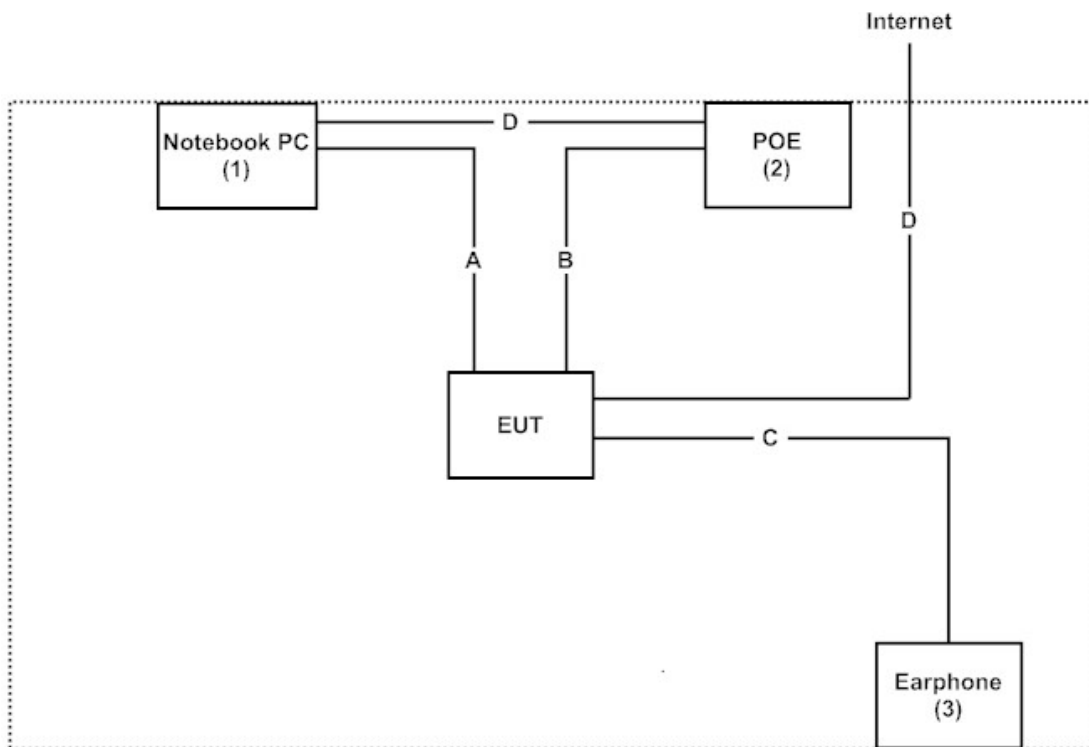

**1.5. EUT Exercise Software**

- (1) Setup the EUT as shown in Section 1.4
- (2) Execute software “USI BCM FCC CE REG Tool V1.4.11” on the Notebook PC.
- (3) Configure the test mode, the test channel, and the data rate.
- (4) Press “OK” to start the continuous Transmit.
- (5) Verify that the EUT works properly.

**1.6. Test Facility**

Ambient conditions in the laboratory:

Items	Required (IEC 68-1)	Actual
Temperature (°C)	15-35	20-35
Humidity (%RH)	25-75	30-65
Barometric pressure (mbar)	860-1060	950-1000

The related certificate for our laboratories about the test site and management system can be downloaded from Quietek Corporation’s Web Site: <http://www.quietek.com/tw/ctg/cts/accreditations.htm>  
 The address and introduction of Quietek Corporation’s laboratories can be founded in our Web site: <http://www.quietek.com/>

Site Description: File on  
 Federal Communications Commission  
 FCC Engineering Laboratory  
 7435 Oakland Mills Road  
 Columbia, MD 21046  
 Registration Number: 92195

Site Name: Quietek Corporation  
 Site Address: No.5-22, Ruishukeng,  
 Linkou Dist. New Taipei City 24451,  
 Taiwan, R.O.C.  
 TEL: 886-2-8601-3788 / FAX : 886-2-8601-3789  
 E-Mail : [service@quietek.com](mailto:service@quietek.com)

FCC Accreditation Number: TW1014



2. Conducted Emission

2.1. Test Equipment

	Equipment	Manufacturer	Model No. / Serial No.	Last Cal.	Remark
X	Test Receiver	R & S	ESCS 30 / 825442/018	Sep., 2014	
X	Artificial Mains Network	R & S	ENV4200 / 848411/10	Feb., 2014	Peripherals
X	LISN	R & S	ESH3-Z5 / 825562/002	Feb., 2014	EUT
	DC LISN	Schwarzbeck	8226 / 176	Mar, 2014	EUT
X	Pulse Limiter	R & S	ESH3-Z2 / 357.8810.52	Feb., 2014	
	No.1 Shielded Room				

Note:

1. All equipments are calibrated every one year.
2. The test instruments marked by “X” are used to measure the final test results.

2.2. Test Setup

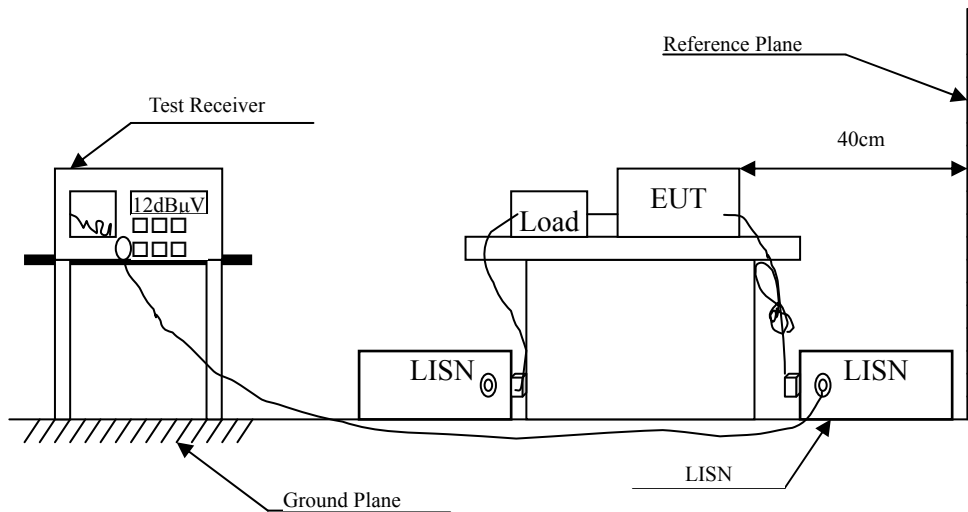

**2.3. Limits**

<b>FCC Part 15 Subpart C Paragraph 15.207 (dBμV) Limit</b>		
Frequency MHz	Limits	
	QP	AV
0.15 - 0.50	66-56	56-46
0.50-5.0	56	46
5.0 - 30	60	50

Remarks: In the above table, the tighter limit applies at the band edges.

**2.4. Test Procedure**

The EUT and Peripherals are connected to the main power through a line impedance stabilization network (L.I.S.N.). This provides a 50 ohm /50uH coupling impedance for the measuring equipment. The peripheral devices are also connected to the main power through a LISN that provides a 50ohm /50uH coupling impedance with 50ohm termination. (Please refer to the block diagram of the test setup and photographs.)

Both sides of A.C. line are checked for maximum conducted interference. In order to find the maximum emission, the relative positions of equipment and all the interface cables must be changed according to ANSI C63.10: 2009 on conducted measurement.

Conducted emissions were investigated over the frequency range from 0.15MHz to 30MHz using a receiver bandwidth of 9kHz.

The EUT was setup to ANSI C63.10, 2009; tested to FHSS test procedure of FCC Public Notice DA 00-705 for compliance to FCC 47CFR 15.247 requirements.

**2.5. Uncertainty**

± 2.26 dB

**2.6. Test Result of Conducted Emission**

Product : VoIP Phone  
 Test Item : Conducted Emission Test  
 Power Line : Line 1  
 Test Mode : Mode 2: Transmit - 3Mbps (8DPSK) (2441MHz)

Frequency MHz	Correct Factor dB	Reading Level dBμV	Measurement Level dBμV	Margin dB	Limit dBμV
<b>LINE 1</b>					
<b>Quasi-Peak</b>					
0.170	9.743	34.220	43.964	-21.465	65.429
0.216	9.739	30.030	39.769	-24.345	64.114
0.334	9.745	27.380	37.125	-23.618	60.743
0.490	9.752	32.180	41.932	-14.354	56.286
0.779	9.765	28.600	38.365	-17.635	56.000
7.920	9.910	27.320	37.230	-22.770	60.000
<b>Average</b>					
0.170	9.743	18.800	28.544	-26.885	55.429
0.216	9.739	22.700	32.439	-21.675	54.114
0.334	9.745	24.340	34.085	-16.658	50.743
0.490	9.752	24.580	34.332	-11.954	46.286
0.779	9.765	20.320	30.085	-15.915	46.000
7.920	9.910	21.530	31.440	-18.560	50.000

Note:

1. All Reading Levels are Quasi-Peak and average value.
2. "█" means the worst emission level.
3. Measurement Level = Reading Level + Correct Factor

Product : VoIP Phone  
 Test Item : Conducted Emission Test  
 Power Line : Line 2  
 Test Mode : Mode 2: Transmit - 3Mbps (8DPSK) (2441MHz)

Frequency MHz	Correct Factor dB	Reading Level dBμV	Measurement Level dBμV	Margin dB	Limit dBμV
<b>LINE 2</b>					
<b>Quasi-Peak</b>					
0.173	9.747	31.650	41.397	-23.946	65.343
0.509	9.753	33.100	42.853	-13.147	56.000
0.771	9.775	28.660	38.435	-17.565	56.000
1.974	9.839	19.840	29.679	-26.321	56.000
6.685	9.900	23.990	33.890	-26.110	60.000
20.920	10.100	24.460	34.560	-25.440	60.000
<b>Average</b>					
0.173	9.747	12.100	21.847	-33.496	55.343
0.509	9.753	21.120	30.873	-15.127	46.000
0.771	9.775	18.660	28.435	-17.565	46.000
1.974	9.839	6.030	15.869	-30.131	46.000
6.685	9.900	16.290	26.190	-23.810	50.000
20.920	10.100	19.050	29.150	-20.850	50.000

Note:

1. All Reading Levels are Quasi-Peak and average value.
2. "█" means the worst emission level.
3. Measurement Level = Reading Level + Correct Factor

**3. Peak Power Output**

**3.1. Test Equipment**

	Equipment	Manufacturer	Model No./Serial No.	Last Cal.
X	Power Meter	Anritsu	ML2495A/6K00003357	May, 2014
X	Power Sensor	Anritsu	MA2411B/0738448	Jun, 2014

Note: 1. All equipments are calibrated every one year.  
 2. The test instruments marked by “X” are used to measure the final test results.

**3.2. Test Setup**

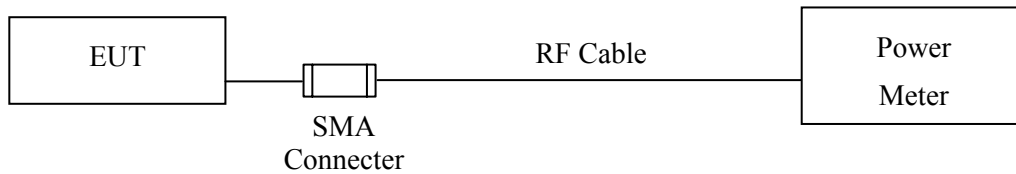

**3.3. Limit**

The maximum peak power shall be less 1Watt.

**3.4. Test Procedure**

The EUT was setup to ANSI C63.10, 2009; tested to FHSS test procedure of FCC Public Notice DA 00-705 for compliance to FCC 47CFR 15.247 requirements.

**3.5. Uncertainty**

± 1.27 dB

**3.6. Test Result of Peak Power Output**

Product : VoIP Phone  
 Test Item : Peak Power Output  
 Test Site : No.3 OATS  
 Test Mode : Mode 1: Transmit - 1Mbps (GFSK)

Channel No.	Frequency (MHz)	Measurement (dBm)	Required Limit	Result
Channel 00	2402.00	1.14	1 Watt= 30 dBm	Pass
Channel 39	2441.00	3.05	1 Watt= 30 dBm	Pass
Channel 78	2480.00	3.10	1 Watt= 30 dBm	Pass

Product : VoIP Phone  
 Test Item : Peak Power Output  
 Test Site : No.3 OATS  
 Test Mode : Mode 2: Transmit - 3Mbps (8DPSK)

Channel No.	Frequency (MHz)	Measurement (dBm)	Required Limit	Result
Channel 00	2402.00	1.20	1 Watt= 30 dBm	Pass
Channel 39	2441.00	2.94	1 Watt= 30 dBm	Pass
Channel 78	2480.00	3.05	1 Watt= 30 dBm	Pass

4. Radiated Emission

4.1. Test Equipment

The following test equipments are used during the radiated emission test:

Test Site		Equipment	Manufacturer	Model No./Serial No.	Last Cal.
Site # 3	X	Bilog Antenna	Schaffner Chase	CBL6112B/2673	Sep., 2014
	X	Horn Antenna	Schwarzbeck	BBHA9120D/D305	Sep., 2014
	X	Horn Antenna	Schwarzbeck	BBHA9170/208	Jul., 2014
	X	Pre-Amplifier	Agilent	8447D/2944A09549	Sep., 2014
	X	Spectrum Analyzer	Agilent	E4407B / US39440758	May, 2014
	X	Test Receiver	R & S	ESCS 30/ 825442/018	Sep., 2014
	X	Coaxial Cable	QuieTek	QTK-CABLE/ CAB5	Feb., 2014
	X	Controller	QuieTek	QTK-CONTROLLER/ CTRL3	N/A
	X	Coaxial Switch	Anritsu	MP59B/6200265729	N/A

- Note: 1. All equipments are calibrated every one year.  
 2. The test instruments marked by "X" are used to measure the final test results.

4.2. Test Setup

Below 1GHz

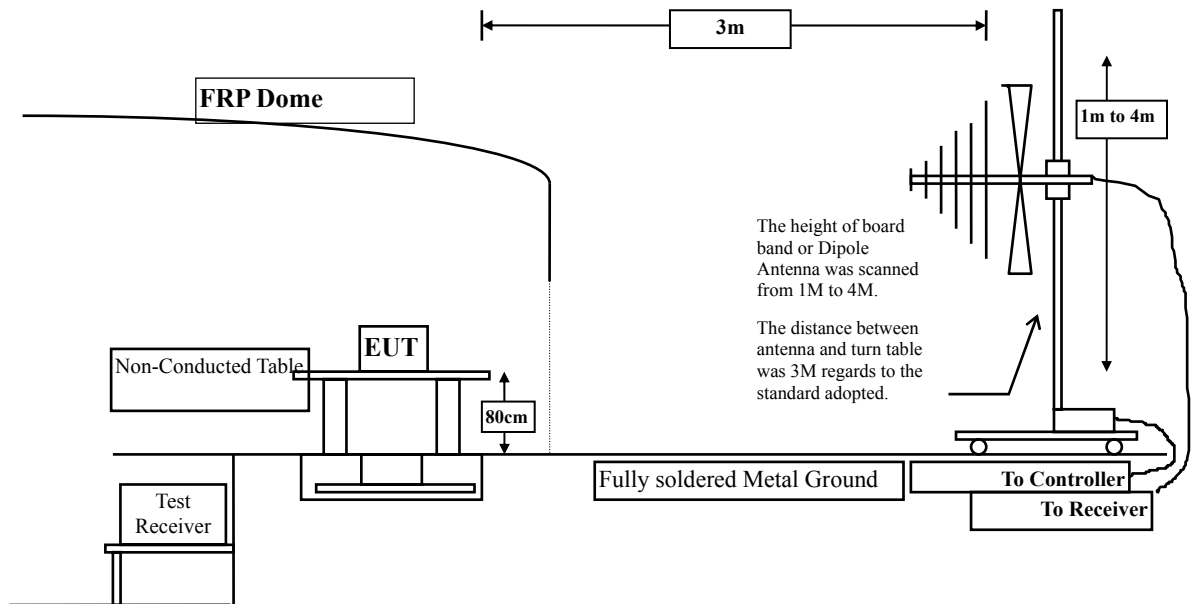



Above 1GHz

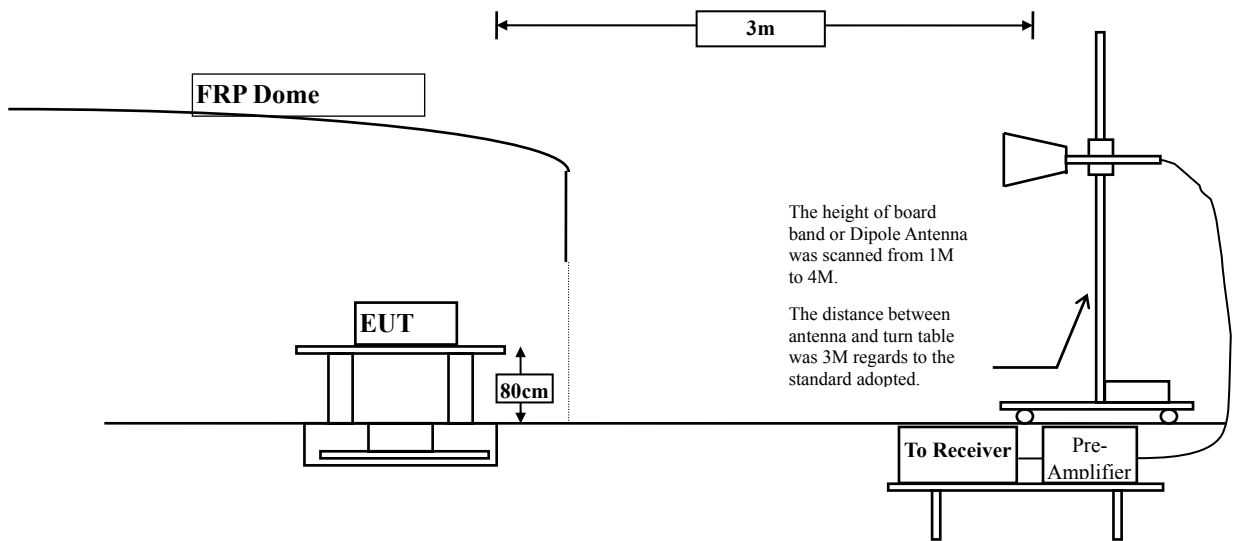

**4.3. Limits**

➤ **General Radiated Emission Limits**

Emissions radiated outside of the specified frequency bands, except for harmonics, shall be attenuated by at least 20dB below the level of the fundamental or to the general radiated emission limits in paragraph 15.209, whichever is the lesser attenuation.

FCC Part 15 Subpart C Paragraph 15.209 Limits		
Frequency MHz	uV/m @3m	dBµV/m@3m
30-88	100	40
88-216	150	43.5
216-960	200	46
Above 960	500	54

- Remarks:
1. RF Voltage (dBµV) = 20 log RF Voltage (uV)
  2. In the Above Table, the tighter limit applies at the band edges.
  3. Distance refers to the distance in meters between the measuring instrument antenna and the closed point of any part of the device or system.

#### 4.4. Test Procedure

The EUT was setup according to ANSI C63.10, 2009 and tested according to FHSS test procedure of FCC Public Notice DA 00-705 for compliance to FCC 47CFR 15.247 requirements.

The EUT is placed on a turn table which is 0.8 meter above ground. The turn table is rotated 360 degrees to determine the position of the maximum emission level. The EUT was positioned such that the distance from antenna to the EUT was 3 meters.

The antenna is scanned from 1 meter to 4 meters to find out the maximum emission level. This is repeated for both horizontal and vertical polarization of the antenna. In order to find the maximum emission, all of the interface cables were manipulated according to ANSI C63.10, 2009 on radiated measurement.

The resolution bandwidth below 1GHz setting on the field strength meter is 120 kHz and above 1GHz is 1MHz.

Radiated emission measurements below 1GHz are made using broadband Bilog antenna and above 1GHz are made using Horn Antennas.

The measurement is divided into the Preliminary Measurement and the Final Measurement.

The suspected frequencies are searched for in Preliminary Measurement with the measurement antenna kept pointed at the source of the emission both in azimuth and elevation, with the polarization of the antenna oriented for maximum response. The antenna is pointed at an angle towards the source of the emission, and the EUT is rotated in both height and polarization to maximize the measured emission. The emission is kept within the illumination area of the 3 dB bandwidth of the antenna.

The worst radiated emission is measured on the Final Measurement.

The measurement frequency range form 9kHz - 10th Harmonic of fundamental was investigated.

#### 4.5. Uncertainty

± 3.9 dB above 1GHz

± 3.8 dB below 1GHz

**4.6. Test Result of Radiated Emission**

Product : VoIP Phone  
 Test Item : Harmonic Radiated Emission  
 Test Site : No.3 OATS  
 Test Mode : Mode 1: Transmit - 1Mbps (GFSK)(2402MHz)

Frequency MHz	Correct Factor dB	Reading Level dBμV	Measurement Level dBμV/m	Margin dB	Limit dBμV/m
<b>Horizontal</b>					
<b>Peak Detector:</b>					
4804.000	2.511	41.941	44.451	-29.549	74.000
7206.000	9.511	38.717	48.228	-25.772	74.000
9608.000	10.394	37.011	47.405	-26.595	74.000
<b>Average Detector:</b>					
--					
<b>Vertical</b>					
<b>Peak Detector:</b>					
4804.000	2.923	43.720	46.642	-27.358	74.000
7206.000	9.988	37.980	47.969	-26.031	74.000
9608.000	10.847	37.430	48.277	-25.723	74.000
<b>Average Detector:</b>					
--					

Note:

1. All Readings below 1GHz are Quasi-Peak, above 1GHz are performed with peak and/or average measurements as necessary.
2. Peak measurements: RBW = 1MHz, VBW = 3 MHz, Sweep: Auto.
3. Average measurements: RBW = 1MHz, VBW = 10 Hz, Sweep: Auto.
4. Measurement Level = Reading Level + Correct Factor.
5. Correct Factor = Antenna factor + Cable loss – Amplifier gain.
6. The average measurement was not performed when the peak measured data under the limit of average detection.
7. The emission levels of other frequencies are very lower than the limit and not show in test report.

Product : VoIP Phone  
 Test Item : Harmonic Radiated Emission  
 Test Site : No.3 OATS  
 Test Mode : Mode 1: Transmit - 1Mbps (GFSK)(2441MHz)

Frequency MHz	Correct Factor dB	Reading Level dB $\mu$ V	Measurement Level dB $\mu$ V/m	Margin dB	Limit dB $\mu$ V/m
<b>Horizontal</b>					
<b>Peak Detector:</b>					
4882.000	2.025	45.631	47.656	-26.344	74.000
7323.000	9.762	37.748	47.509	-26.491	74.000
9764.000	9.682	37.592	47.273	-26.727	74.000
<b>Average Detector:</b>					
--					
<b>Vertical</b>					
<b>Peak Detector:</b>					
4882.000	2.488	46.518	49.006	-24.994	74.000
7323.000	10.375	38.772	49.146	-24.854	74.000
9764.000	10.315	37.152	47.467	-26.533	74.000
<b>Average Detector:</b>					
--					

Note:

1. All Readings below 1GHz are Quasi-Peak, above 1GHz are performed with peak and/or average measurements as necessary.
2. Peak measurements: RBW = 1MHz, VBW = 3 MHz, Sweep: Auto.
3. Average measurements: RBW = 1MHz, VBW = 10 Hz, Sweep: Auto.
4. Measurement Level = Reading Level + Correct Factor.
5. Correct Factor = Antenna factor + Cable loss – Amplifier gain.
6. The average measurement was not performed when the peak measured data under the limit of average detection.
7. The emission levels of other frequencies are very lower than the limit and not show in test report.

Product : VoIP Phone  
 Test Item : Harmonic Radiated Emission  
 Test Site : No.3 OATS  
 Test Mode : Mode 1: Transmit - 1Mbps (GFSK)(2480MHz)

Frequency MHz	Correct Factor dB	Reading Level dBμV	Measurement Level dBμV/m	Margin dB	Limit dBμV/m
<b>Horizontal</b>					
<b>Peak Detector:</b>					
4960.000	2.582	46.207	48.789	-25.211	74.000
7440.000	10.555	36.844	47.399	-26.601	74.000
9920.000	10.206	37.481	47.687	-26.313	74.000
<b>Average Detector:</b>					
--					
<b>Vertical</b>					
<b>Peak Detector:</b>					
4960.000	3.398	48.944	52.343	-21.657	74.000
7440.000	11.214	36.948	48.162	-25.838	74.000
9920.000	11.245	36.867	48.112	-25.888	74.000
<b>Average Detector:</b>					
--					

Note:

1. All Readings below 1GHz are Quasi-Peak, above 1GHz are performed with peak and/or average measurements as necessary.
2. Peak measurements: RBW = 1MHz, VBW = 3 MHz, Sweep: Auto.
3. Average measurements: RBW = 1MHz, VBW = 10 Hz, Sweep: Auto.
4. Measurement Level = Reading Level + Correct Factor.
5. Correct Factor = Antenna factor + Cable loss – Amplifier gain.
6. The average measurement was not performed when the peak measured data under the limit of average detection.
7. The emission levels of other frequencies are very lower than the limit and not show in test report.

Product : VoIP Phone  
 Test Item : Harmonic Radiated Emission  
 Test Site : No.3 OATS  
 Test Mode : Mode 2: Transmit - 3Mbps (8DPSK)(2402MHz)

Frequency MHz	Correct Factor dB	Reading Level dBμV	Measurement Level dBμV/m	Margin dB	Limit dBμV/m
<b>Horizontal</b>					
<b>Peak Detector:</b>					
4804.000	2.511	44.288	46.798	-27.202	74.000
7206.000	9.511	37.995	47.506	-26.494	74.000
9608.000	10.394	37.059	47.453	-26.547	74.000
<b>Average Detector:</b>					
--					
<b>Vertical</b>					
<b>Peak Detector:</b>					
4804.000	2.511	44.288	46.798	-27.202	74.000
7206.000	9.511	37.995	47.506	-26.494	74.000
9608.000	10.394	37.059	47.453	-26.547	74.000
<b>Average Detector:</b>					
--					

Note:

1. All Readings below 1GHz are Quasi-Peak, above 1GHz are performed with peak and/or average measurements as necessary.
2. Peak measurements: RBW = 1MHz, VBW = 3 MHz, Sweep: Auto.
3. Average measurements: RBW = 1MHz, VBW = 10 Hz, Sweep: Auto.
4. Measurement Level = Reading Level + Correct Factor.
5. Correct Factor = Antenna factor + Cable loss – Amplifier gain.
6. The average measurement was not performed when the peak measured data under the limit of average detection.
7. The emission levels of other frequencies are very lower than the limit and not show in test report.

Product : VoIP Phone  
 Test Item : Harmonic Radiated Emission  
 Test Site : No.3 OATS  
 Test Mode : Mode 2: Transmit - 3Mbps (8DPSK) (2441MHz)

Frequency MHz	Correct Factor dB	Reading Level dBµV	Measurement Level dBµV/m	Margin dB	Limit dBµV/m
<b>Horizontal</b>					
<b>Peak Detector:</b>					
4882.000	2.025	46.620	48.645	-25.355	74.000
7323.000	9.762	38.224	47.985	-26.015	74.000
9764.000	9.682	37.719	47.400	-26.600	74.000
<b>Average Detector:</b>					
--					
<b>Vertical</b>					
<b>Peak Detector:</b>					
4882.000	2.025	46.620	48.645	-25.355	74.000
7323.000	9.762	38.224	47.985	-26.015	74.000
9764.000	9.682	37.719	47.400	-26.600	74.000
<b>Average Detector:</b>					
--					

Note:

1. All Readings below 1GHz are Quasi-Peak, above 1GHz are performed with peak and/or average measurements as necessary.
2. Peak measurements: RBW = 1MHz, VBW = 3 MHz, Sweep: Auto.
3. Average measurements: RBW = 1MHz, VBW = 10 Hz, Sweep: Auto.
4. Measurement Level = Reading Level + Correct Factor.
5. Correct Factor = Antenna factor + Cable loss – Amplifier gain.
6. The average measurement was not performed when the peak measured data under the limit of average detection.
7. The emission levels of other frequencies are very lower than the limit and not show in test report.

Product : VoIP Phone  
 Test Item : Harmonic Radiated Emission  
 Test Site : No.3 OATS  
 Test Mode : Mode 2: Transmit - 3Mbps (8DPSK) (2480MHz)

Frequency MHz	Correct Factor dB	Reading Level dBμV	Measurement Level dBμV/m	Margin dB	Limit dBμV/m
<b>Horizontal</b>					
<b>Peak Detector:</b>					
4960.000	2.582	48.152	50.734	-23.266	74.000
7440.000	10.555	37.439	47.994	-26.006	74.000
9920.000	10.206	37.595	47.801	-26.199	74.000
<b>Average Detector:</b>					
--					
<b>Vertical</b>					
<b>Peak Detector:</b>					
4960.000	3.398	51.471	54.870	-19.130	74.000
7440.000	11.214	37.534	48.748	-25.252	74.000
9920.000	11.245	36.952	48.197	-25.803	74.000
<b>Average Detector:</b>					
4960.000	3.398	40.724	44.123	-9.877	54.000

Note:

1. All Readings below 1GHz are Quasi-Peak, above 1GHz are performed with peak and/or average measurements as necessary.
2. Peak measurements: RBW = 1MHz, VBW = 3 MHz, Sweep: Auto.
3. Average measurements: RBW = 1MHz, VBW = 10 Hz, Sweep: Auto.
4. Measurement Level = Reading Level + Correct Factor.
5. Correct Factor = Antenna factor + Cable loss – Amplifier gain.
6. The average measurement was not performed when the peak measured data under the limit of average detection.
7. The emission levels of other frequencies are very lower than the limit and not show in test report.



Product : VoIP Phone  
 Test Item : General Radiated Emission  
 Test Site : No.3 OATS  
 Test Mode : Mode 1: Transmit - 1Mbps (GFSK) (2441MHz)

Frequency MHz	Correct Factor dB	Reading Level dBµV	Measurement Level dBµV/m	Margin dB	Limit dBµV/m
<b>Horizontal</b>					
204.600	-10.493	44.731	34.238	-9.262	43.500
344.280	-1.814	41.486	39.672	-6.328	46.000
431.580	0.757	40.946	41.703	-4.297	46.000
601.330	3.563	34.471	38.034	-7.966	46.000
711.910	3.788	32.086	35.874	-10.126	46.000
911.730	6.471	35.119	41.590	-4.410	46.000
<b>Vertical</b>					
86.260	-4.042	35.587	31.545	-8.455	40.000
204.600	-5.473	44.753	39.280	-4.220	43.500
398.600	-2.371	41.757	39.386	-6.614	46.000
527.610	1.153	38.292	39.445	-6.555	46.000
601.330	1.463	34.016	35.479	-10.521	46.000
911.730	0.241	35.097	35.338	-10.662	46.000

Note:

1. All Readings below 1GHz are Quasi-Peak, above 1GHz are performed with peak and/or average measurements as necessary.
2. Peak measurements: RBW = 1MHz, VBW = 3 MHz, Sweep: Auto.
3. Average measurements: RBW = 1MHz, VBW = 10 Hz, Sweep: Auto.
4. Measurement Level = Reading Level + Correct Factor.
5. Correct Factor = Antenna factor + Cable loss –Amplifier gain.
6. The average measurement was not performed when the peak measured data under the limit of average detection.
7. The emission levels of other frequencies are very lower than the limit and not show in test report.
8. No emission found between lowest internal used/generated frequency to 30MHz.

Product : VoIP Phone  
 Test Item : General Radiated Emission  
 Test Site : No.3 OATS  
 Test Mode : Mode 2: Transmit - 3Mbps (8DPSK) (2441MHz)

Frequency MHz	Correct Factor dB	Reading Level dBμV	Measurement Level dBμV/m	Margin dB	Limit dBμV/m
<b>Horizontal</b>					
187.140	-11.217	48.747	37.530	-5.970	43.500
376.290	1.003	36.766	37.769	-8.231	46.000
500.450	2.035	36.804	38.839	-7.161	46.000
624.610	1.507	35.309	36.816	-9.184	46.000
815.700	6.451	29.584	36.035	-9.965	46.000
911.730	6.471	32.300	38.771	-7.229	46.000
<b>Vertical</b>					
204.600	-5.473	45.290	39.817	-3.683	43.500
398.600	-2.371	41.030	38.659	-7.341	46.000
527.610	1.153	38.123	39.276	-6.724	46.000
601.330	1.463	33.880	35.343	-10.657	46.000
711.910	-1.132	32.303	31.171	-14.829	46.000
911.730	0.241	34.888	35.129	-10.871	46.000

Note:

1. All Readings below 1GHz are Quasi-Peak, above 1GHz are performed with peak and/or average measurements as necessary.
2. Peak measurements: RBW = 1MHz, VBW = 3 MHz, Sweep: Auto.
3. Average measurements: RBW = 1MHz, VBW = 10 Hz, Sweep: Auto.
4. Measurement Level = Reading Level + Correct Factor.
5. Correct Factor = Antenna factor + Cable loss – Amplifier gain.
6. The average measurement was not performed when the peak measured data under the limit of average detection.
7. The emission levels of other frequencies are very lower than the limit and not show in test report.
8. No emission found between lowest internal used/generated frequency to 30MHz.

**5. RF Antenna Conducted Test**

**5.1. Test Equipment**

Equipment	Manufacturer	Model No./Serial No.	Last Cal.
Spectrum Analyzer	R&S	FSP40 / 100170	Jun, 2014
Spectrum Analyzer	Agilent	E4407B / US39440758	Jun, 2014
X Spectrum Analyzer	Agilent	N9010A / MY48030495	Apr., 2014

Note: 1. All equipments are calibrated every one year.  
 2. The test instruments Marked “X” are used to measure the final test results.

**5.2. Test Setup**

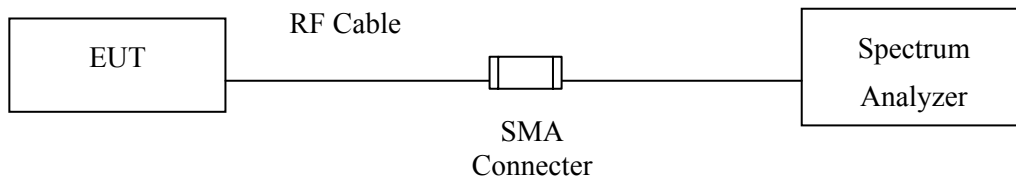

**5.3. Limits**

According to FCC Section 15.247(d). In any 100 kHz bandwidth outside the frequency band in which the spread spectrum or digitally modulated intentional radiator is operating, the radio frequency power that is produced by the intentional radiator shall be at least 20 dB below that in the 100 kHz bandwidth within the band that contains the highest level of the desired power, based on either an RF conducted or measurement, provided the transmitter demonstrates compliance with the peak conducted power limits. If the transmitter complies with the conducted power limits based on the use of RMS averaging over a time interval, the attenuation required under this paragraph shall be 30 dB instead of 20 dB.

**5.4. Test Procedure**

The EUT was setup to ANSI C63.10, 2009; tested to FHSS test procedure of FCC Public Notice DA 00-705 for compliance to FCC 47CFR 15.247 requirements.

**5.5. Uncertainty**

± 150Hz

**5.6. Test Result of RF Antenna Conducted Test**

Product : VoIP Phone  
 Test Item : RF Antenna Conducted Test  
 Test Site : No.3 OATS  
 Test Mode : Mode 1: Transmit - 1Mbps (GFSK)

**Figure Channel 00:**

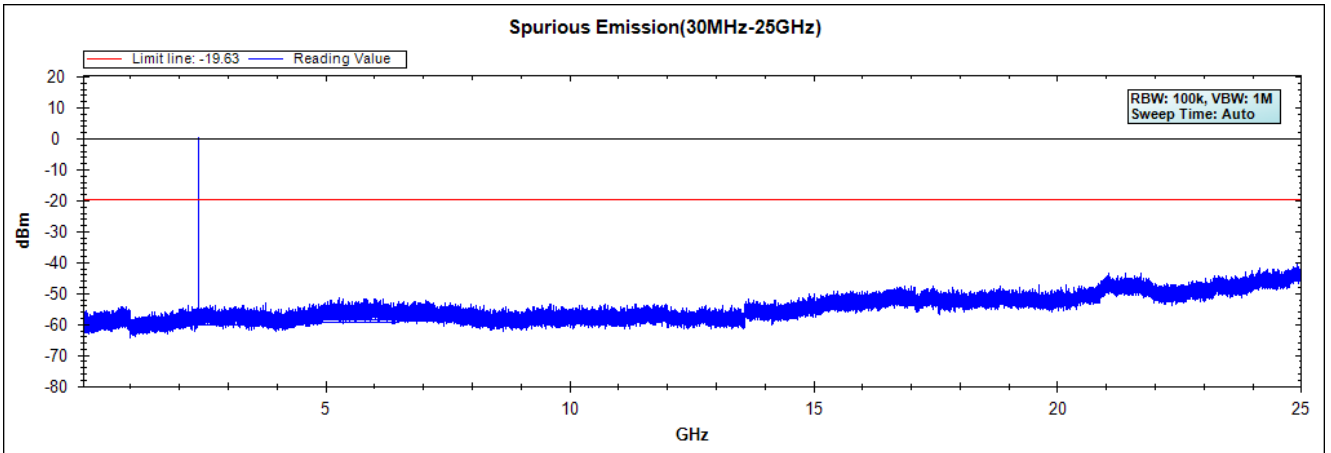

**Figure Channel 39:**

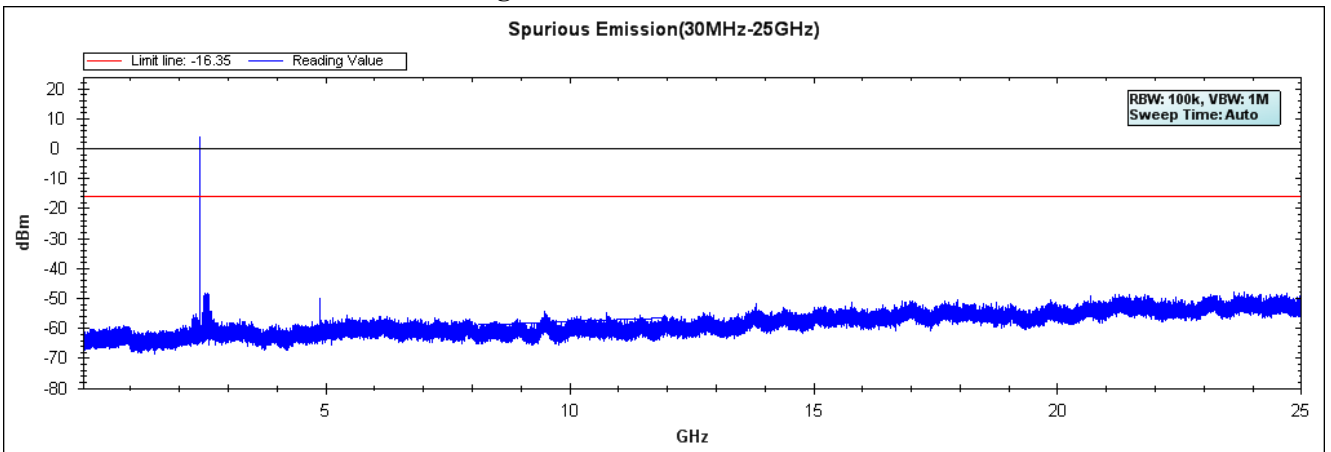

**Figure Channel 78:**

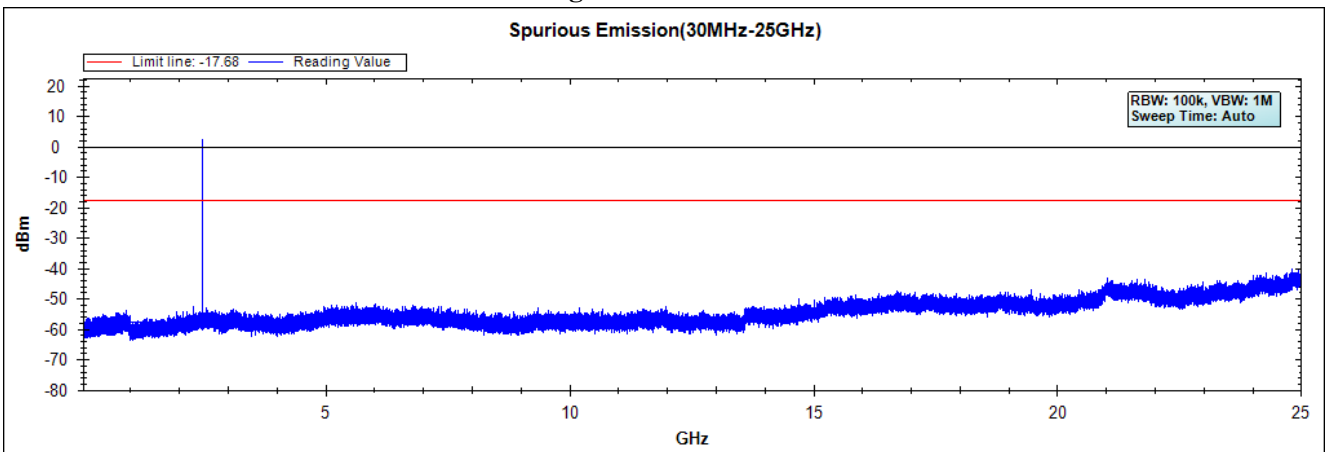

Note: The above test pattern is synthesized by multiple of the frequency range.

Product : VoIP Phone  
Test Item : RF Antenna Conducted Test  
Test Site : No.3 OATS  
Test Mode : Mode 2: Transmit - 3Mbps (8DPSK)

Figure Channel 00:

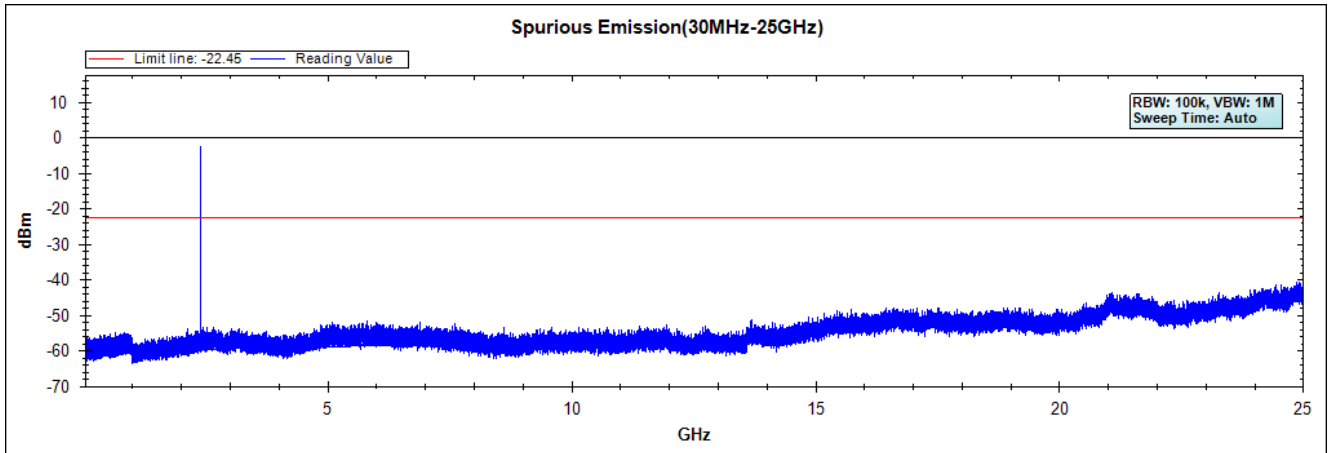

Figure Channel 39:

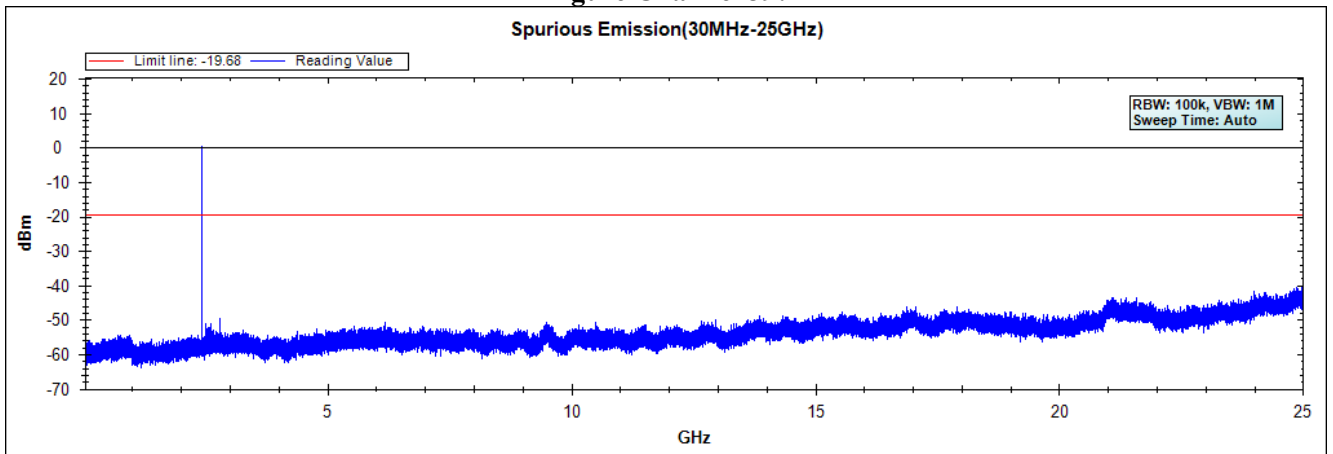
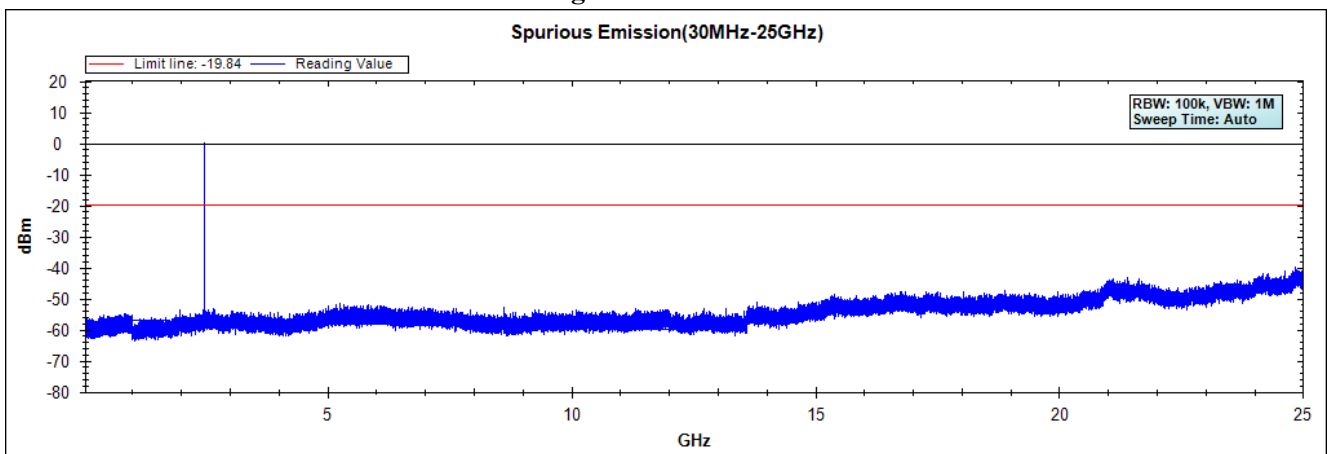

Figure Channel 78:



Note: The above test pattern is synthesized by multiple of the frequency range.

Product : VoIP Phone  
 Test Item : RF Antenna Conducted Test  
 Test Site : No.3 OATS  
 Test Mode : Mode 1: Transmit - 1Mbps (GFSK)-Hopping mode

**Hopping mode**

	Measurement Level (dBc)	Limit
Low channel	40.947	>20dBc
High channel	53.402	>20dBc

Conducted Band edge –Low channel

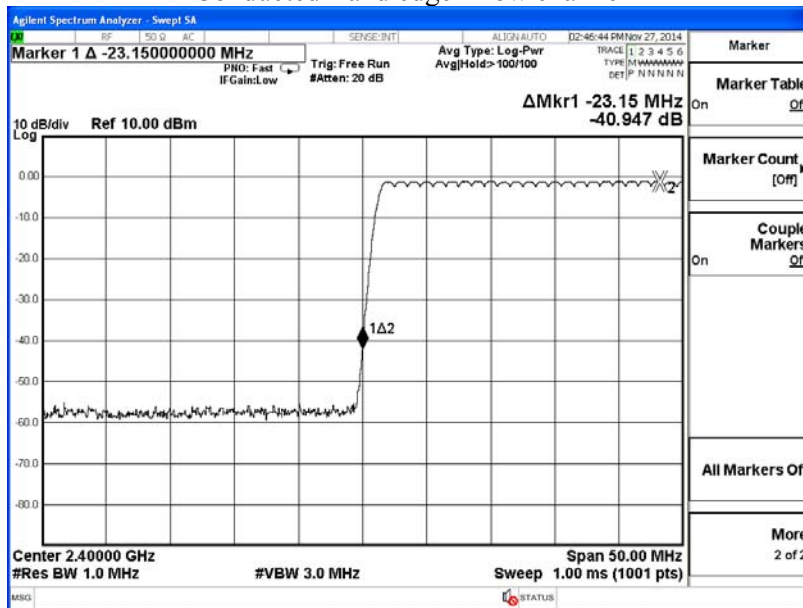

Conducted Band edge –High channel

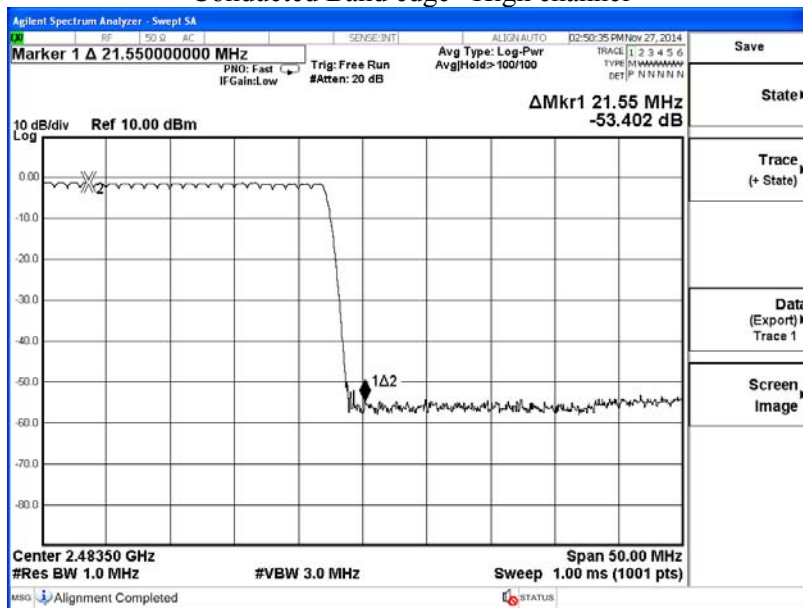

Product : VoIP Phone  
 Test Item : RF Antenna Conducted Test  
 Test Site : No.3 OATS  
 Test Mode : Mode 2: Transmit - 3Mbps (8DPSK)

**Hopping mode**

	Measurement Level (dBc)	Limit
Low channel	32.959	>20dBc
High channel	47.950	>20dBc

Conducted Band edge –Low channel

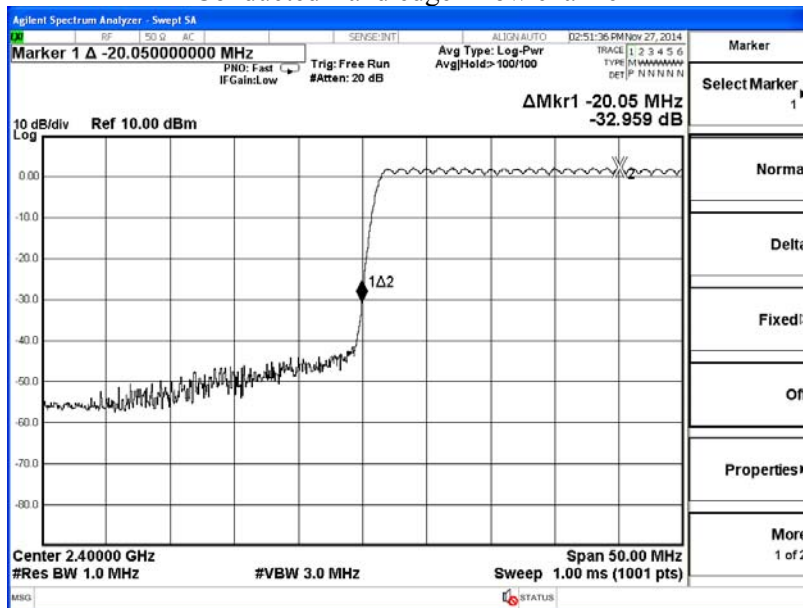

Conducted Band edge –High channel

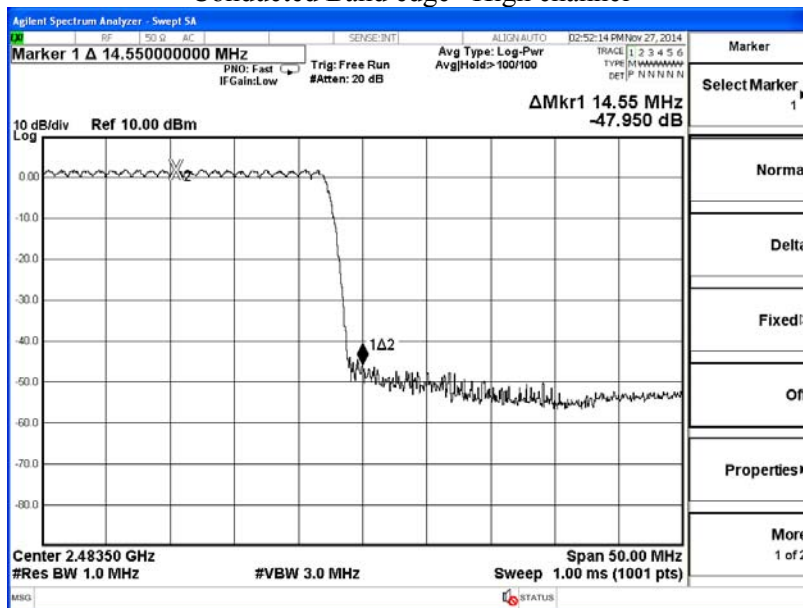

6. Band Edge

6.1. Test Equipment

**RF Radiated Measurement:**

The following test equipments are used during the band edge tests:

Test Site	Equipment	Manufacturer	Model No./Serial No.	Last Cal.
☒ Site # 3	Bilog Antenna	Schaffner Chase	CBL6112B/2673	Sep., 2014
	X Horn Antenna	Schwarzbeck	BBHA9120D/D305	Sep., 2014
	Horn Antenna	Schwarzbeck	BBHA9170/208	Jul., 2014
	X Pre-Amplifier	Agilent	8447D/2944A09549	Sep., 2014
	X Spectrum Analyzer	Agilent	E4407B / US39440758	May, 2014
	Test Receiver	R & S	ESCS 30/ 825442/018	Sep., 2014
	X Coaxial Cable	QuieTek	QTK-CABLE/ CAB5	Feb., 2014
	X Controller	QuieTek	QTK-CONTROLLER/ CTRL3	N/A
	X Coaxial Switch	Anritsu	MP59B/6200265729	N/A

- Note:
1. All equipments are calibrated every one year.
  2. The test instruments marked by “X” are used to measure the final test results.

6.2. Test Setup

**RF Radiated Measurement:**

Above 1GHz

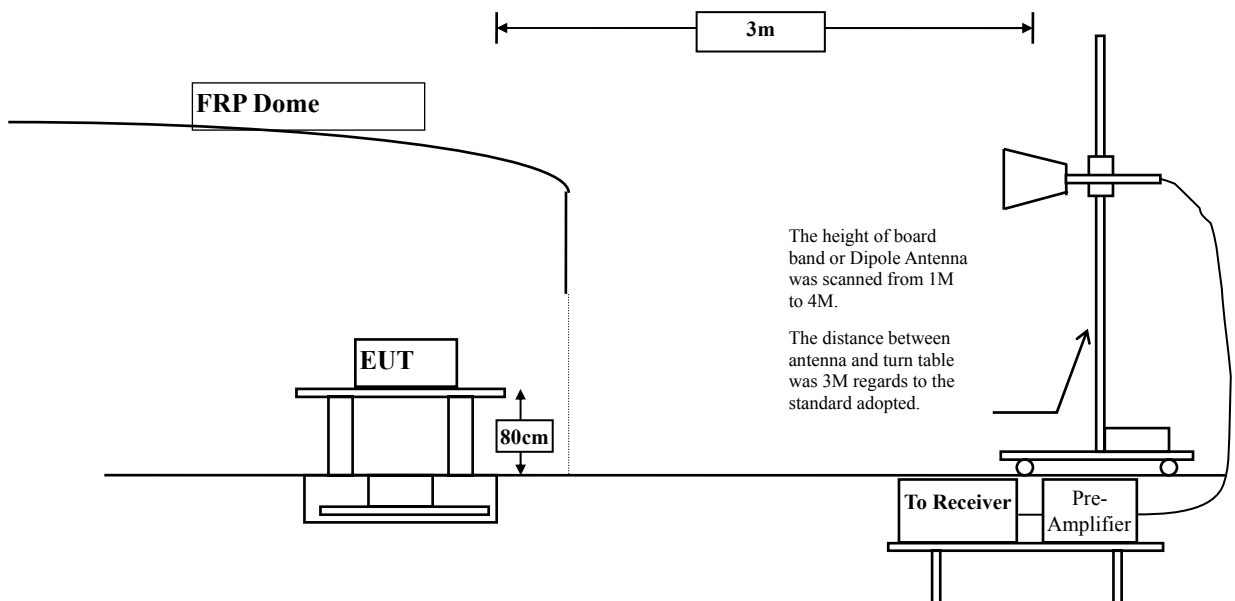



### 6.3. Limit

In any 100 kHz bandwidth outside the frequency band in which the spread spectrum intentional radiator is operating, the radio frequency power that is produced by the intentional radiator shall be at least 20 dB below that in the 100 kHz bandwidth within the band that contains the highest level of the desired power, based on either an RF conducted or a radiated measurement. Attenuation below the general limits specified in Section 15.209(a) is not required. In addition, radiated emissions which fall in the restricted bands, as defined in Section 15.205(a), must also comply with the radiated emission limits specified in Section 15.209(a) (see Section 15.205(c)).

### 6.4. Test Procedure

The EUT and its simulators are placed on a turn table which is 0.8 meter above ground. The turn table can rotate 360 degrees to determine the position of the maximum emission level. The EUT was positioned such that the distance from antenna to the EUT was 3 meters.

The antenna can move up and down between 1 meter and 4 meters to find out the maximum emission level.

Both horizontal and vertical polarization of the antenna are set on measurement. In order to find the maximum emission, all of the interface cables must be manipulated according to ANSI C63.4:2003 on radiated measurement.

The bandwidth below 1GHz setting on the field strength meter is 120 kHz, above 1GHz are 1 MHz. The EUT was setup to ANSI C63.10, 2009; tested to FHSS test procedure of FCC Public Notice DA 00-705 for compliance to FCC 47CFR 15.247 requirements.

### 6.5. Uncertainty

± 3.9 dB above 1GHz

± 3.8 dB below 1GHz

**6.6. Test Result of Band Edge**

Product : VoIP Phone  
 Test Item : Band Edge  
 Test Site : No.3 OATS  
 Test Mode : Mode 1: Transmit - 1Mbps (GFSK)

**RF Radiated Measurement (Horizontal):**

Channel No.	Frequency (MHz)	Correct Factor (dB)	Reading Level (dBμV)	Emission Level (dBμV/m)	Peak Limit (dBμV/m)	Average Limit (dBμV/m)	Result
00 (Peak)	2390.000	-2.687	50.919	48.232	74.00	54.00	Pass
00 (Peak)	2400.000	-2.660	62.290	59.630	--	--	--
00 (Peak)	2402.100	-2.657	96.469	93.812	--	--	--
00 (Average)	2390.000	-2.687	38.394	35.707	74.00	54.00	Pass
00 (Average)	2400.000	-2.660	44.732	42.072	--	--	--
00 (Average)	2402.100	-2.657	84.220	81.563	--	--	--

**Figure Channel 00: Horizontal (Peak)**

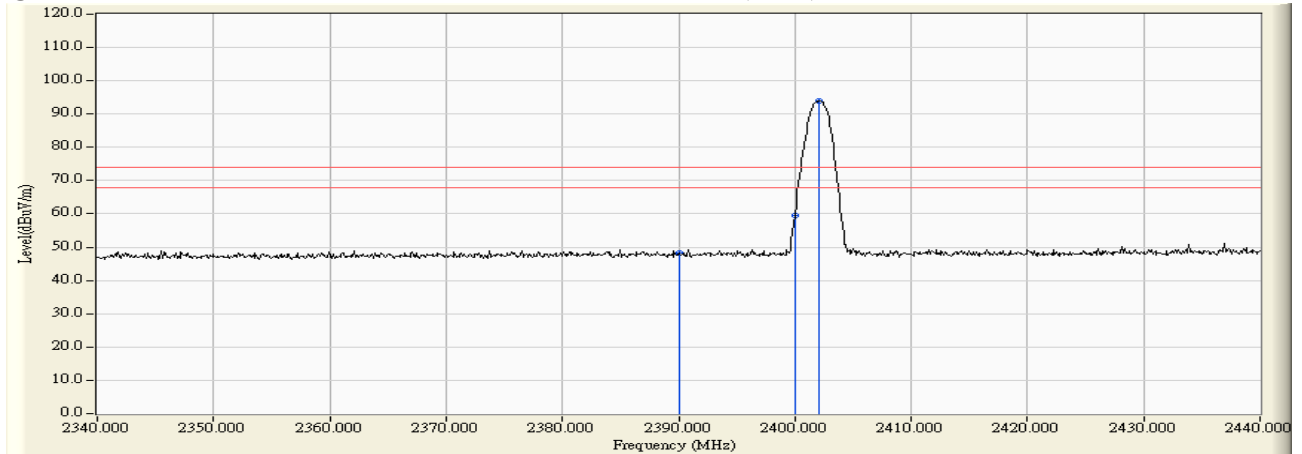

**Figure Channel 00: Horizontal (Average)**

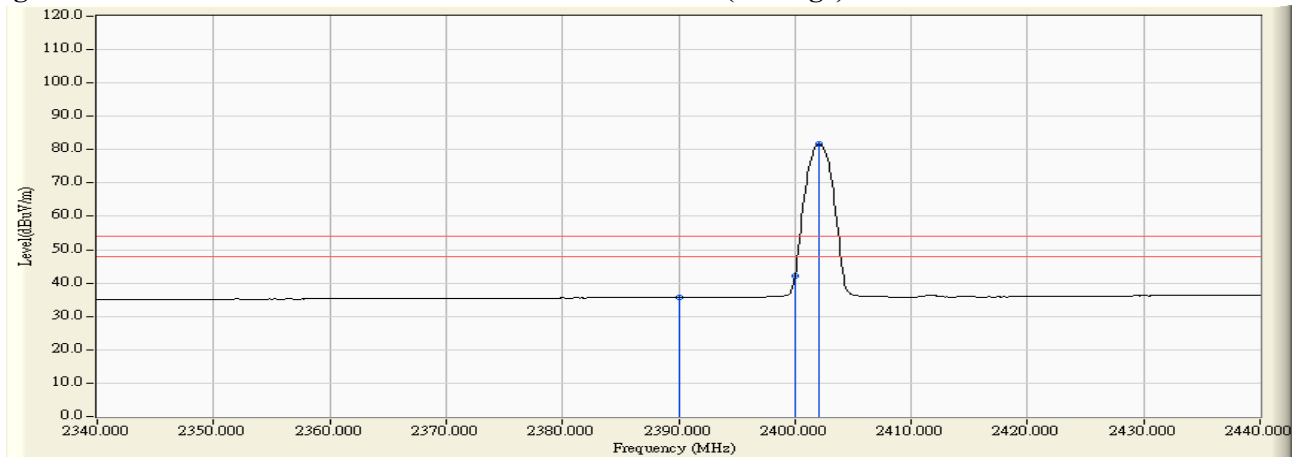

Note:

1. All readings above 1GHz are performed with peak and/or average measurements as necessary.
2. Peak measurements: RBW = 1MHz, VBW = 3 MHz, Sweep: Auto.
3. Average measurements: RBW = 1MHz, VBW = 10 Hz, Sweep: Auto.
4. “ \* ”, means this data is the worst emission level.
5. Measurement Level = Reading Level + Correct Factor.
6. The average measurement was not performed when the peak measured data under the limit of average detection.

Product : VoIP Phone  
 Test Item : Band Edge  
 Test Site : No.3 OATS  
 Test Mode : Mode 1: Transmit - 1Mbps (GFSK)

**RF Radiated Measurement (Vertical):**

Channel No.	Frequency (MHz)	Correct Factor (dB)	Reading Level (dBμV)	Emission Level (dBμV/m)	Peak Limit (dBμV/m)	Average Limit (dBμV/m)	Result
00 (Peak)	2388.300	-4.153	52.702	48.549	74.00	54.00	Pass
00 (Peak)	2390.000	-4.159	51.657	47.498	74.00	54.00	Pass
00 (Peak)	2400.000	-4.171	56.639	52.468	--	--	--
00 (Peak)	2402.200	-4.171	91.137	86.966	--	--	--
00 (Average)	2390.000	-4.159	38.283	34.124	74.00	54.00	Pass
00 (Average)	2400.000	-4.171	42.205	38.034	--	--	--
00 (Average)	2402.100	-4.171	79.959	75.788	--	--	--

**Figure Channel 00: Vertical (Peak)**

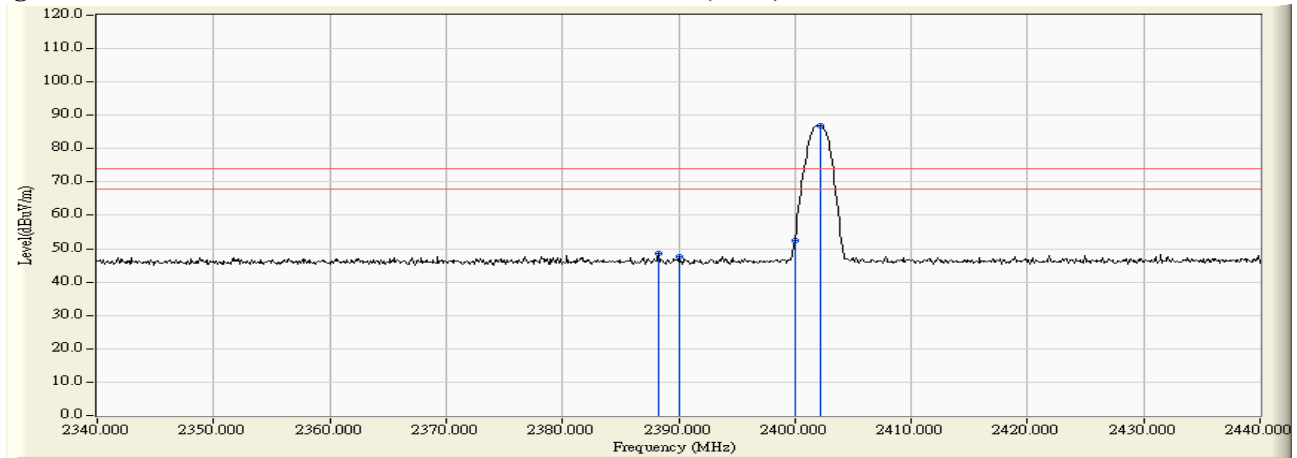

**Figure Channel 00: Vertical (Average)**

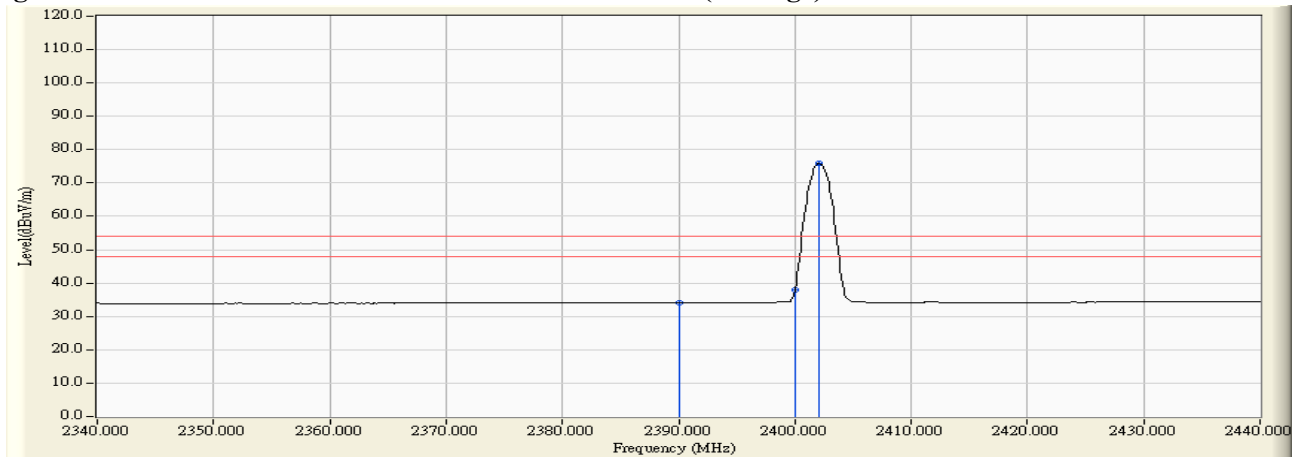

Note:

1. All readings above 1GHz are performed with peak and/or average measurements as necessary.
2. Peak measurements: RBW = 1MHz, VBW = 3 MHz, Sweep: Auto.
3. Average measurements: RBW = 1MHz, VBW = 10 Hz, Sweep: Auto.
4. “ \* ”, means this data is the worst emission level.
5. Measurement Level = Reading Level + Correct Factor.
6. The average measurement was not performed when the peak measured data under the limit of average detection.

Product : VoIP Phone  
 Test Item : Band Edge  
 Test Site : No.3 OATS  
 Test Mode : Mode 1: Transmit - 1Mbps (GFSK)

**RF Radiated Measurement (Horizontal):**

Channel No.	Frequency (MHz)	Correct Factor (dB)	Reading Level (dBμV)	Emission Level (dBμV/m)	Peak Limit (dBμV/m)	Average Limit (dBμV/m)	Result
78 (Peak)	2480.200	-2.605	101.796	99.191	--	--	--
78 (Peak)	2483.500	-2.601	51.732	49.130	74.00	54.00	Pass
78 (Peak)	2489.500	-2.595	52.816	50.220	74.00	54.00	Pass
78 (Average)	2480.100	-2.605	88.518	85.913	--	--	--
78 (Average)	2483.500	-2.601	39.567	36.965	74.00	54.00	Pass

**Figure Channel 78: Horizontal (Peak)**

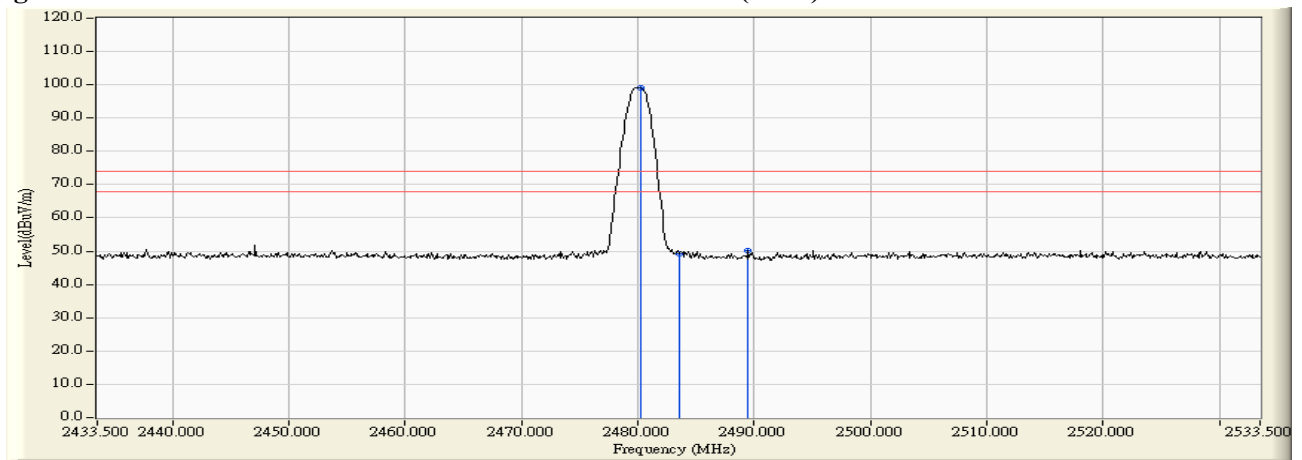

**Figure Channel 78: Horizontal (Average)**

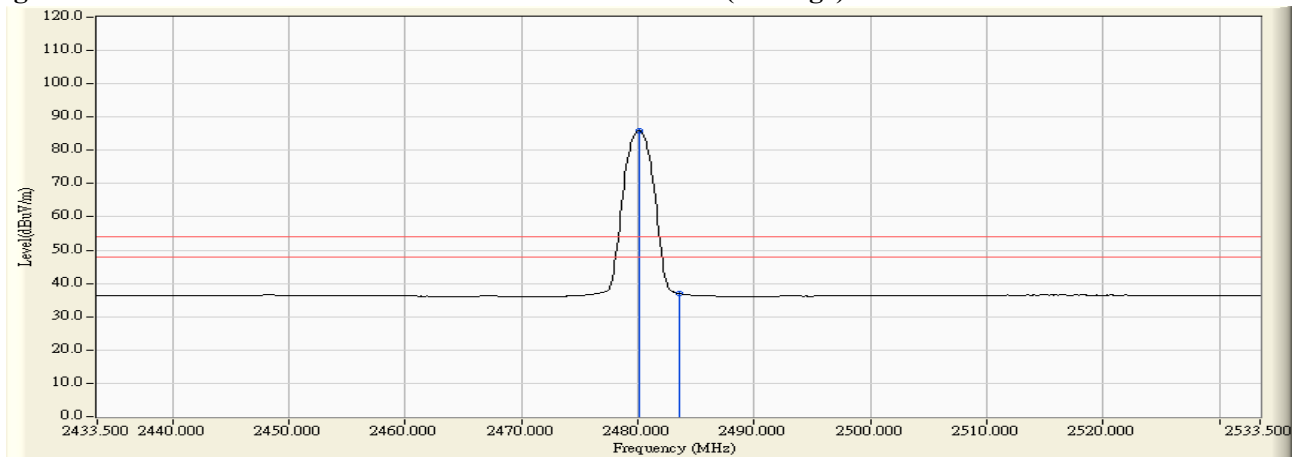

Note:

1. All readings above 1GHz are performed with peak and/or average measurements as necessary.
2. Peak measurements: RBW = 1MHz, VBW = 3 MHz, Sweep: Auto.
3. Average measurements: RBW = 1MHz, VBW = 10 Hz, Sweep: Auto.
4. “ \* ”, means this data is the worst emission level.
5. Measurement Level = Reading Level + Correct Factor.
6. The average measurement was not performed when the peak measured data under the limit of average detection.

Product : VoIP Phone  
 Test Item : Band Edge  
 Test Site : No.3 OATS  
 Test Mode : Mode 1: Transmit - 1Mbps (GFSK)

**RF Radiated Measurement (Vertical):**

Channel No.	Frequency (MHz)	Correct Factor (dB)	Reading Level (dBμV)	Emission Level (dBμV/m)	Peak Limit (dBμV/m)	Average Limit (dBμV/m)	Result
78 (Peak)	2479.900	-3.978	94.488	90.510	--	--	--
78 (Peak)	2483.500	-3.966	51.131	47.164	74.00	54.00	Pass
78 (Peak)	2485.600	-3.961	51.901	47.941	74.00	54.00	Pass
78 (Average)	2480.100	-3.977	82.672	78.695	--	--	--
78 (Average)	2483.500	-3.966	38.510	34.543	74.00	54.00	Pass

**Figure Channel 78: Vertical (Peak)**

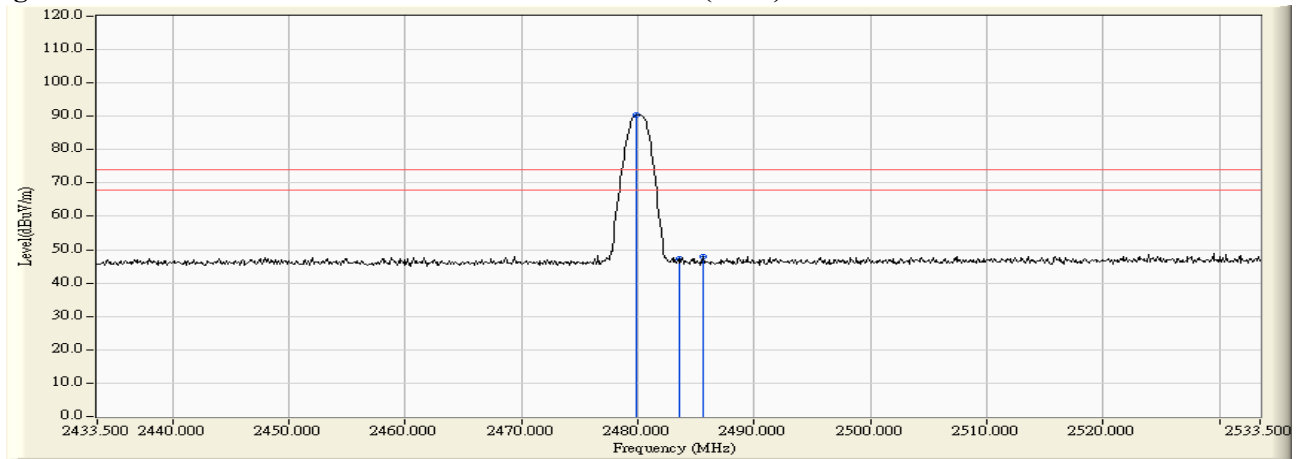

**Figure Channel 78: Vertical (Average)**

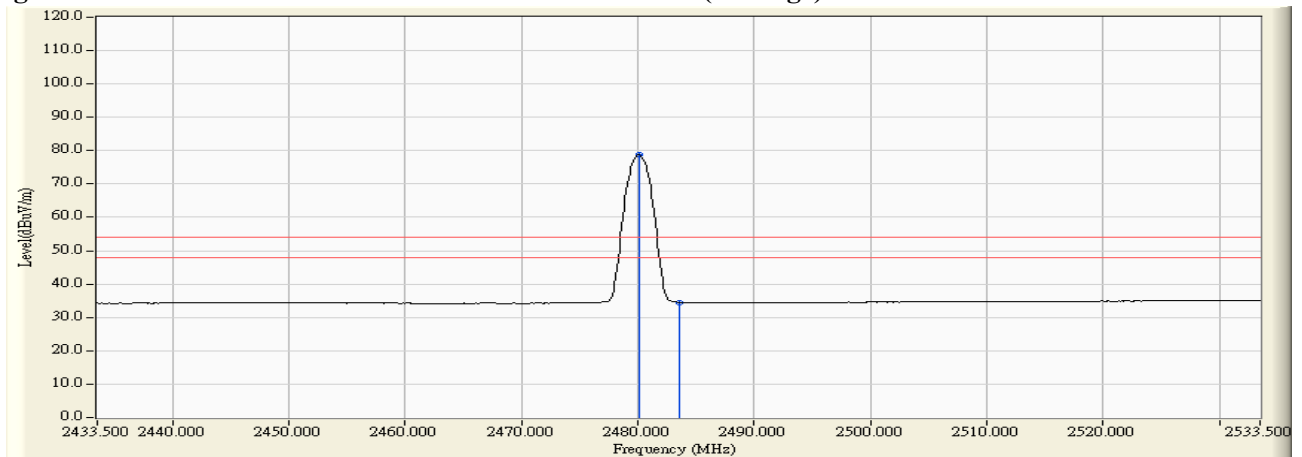

**Note:**

1. All readings above 1GHz are performed with peak and/or average measurements as necessary.
2. Peak measurements: RBW = 1MHz, VBW = 3 MHz, Sweep: Auto.
3. Average measurements: RBW = 1MHz, VBW = 10 Hz, Sweep: Auto.
4. “ \* ”, means this data is the worst emission level.
5. Measurement Level = Reading Level + Correct Factor.
6. The average measurement was not performed when the peak measured data under the limit of average detection.

Product : VoIP Phone  
 Test Item : Band Edge  
 Test Site : No.3 OATS  
 Test Mode : Mode 2: Transmit - 3Mbps (8DPSK)

**RF Radiated Measurement (Horizontal):**

Channel No.	Frequency (MHz)	Correct Factor (dB)	Reading Level (dBμV)	Emission Level (dBμV/m)	Peak Limit (dBμV/m)	Average Limit (dBμV/m)	Result
00 (Peak)	2374.400	-2.756	52.346	49.590	74.00	54.00	Pass
00 (Peak)	2390.000	-2.687	50.633	47.946	74.00	54.00	Pass
00 (Peak)	2400.000	-2.660	63.909	61.249	--	--	--
00 (Peak)	2402.000	-2.657	98.471	95.814	--	--	--
00 (Average)	2390.000	-2.687	38.391	35.704	74.00	54.00	Pass
00 (Average)	2400.000	-2.660	50.499	47.839	--	--	--
00 (Average)	2402.100	-2.657	83.231	80.574	--	--	--

**Figure Channel 00: Horizontal (Peak)**

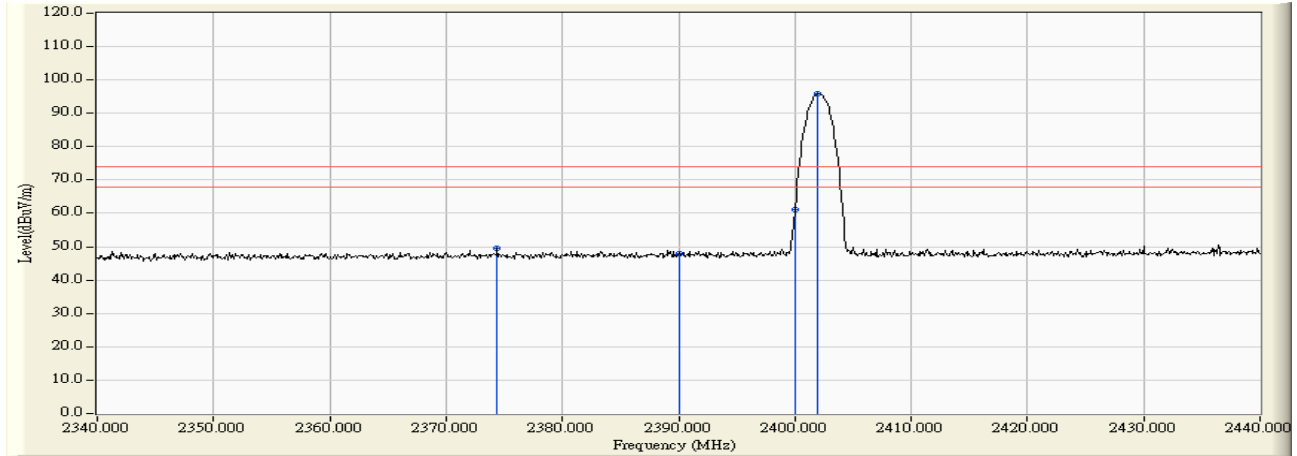

**Figure Channel 00: Horizontal (Average)**

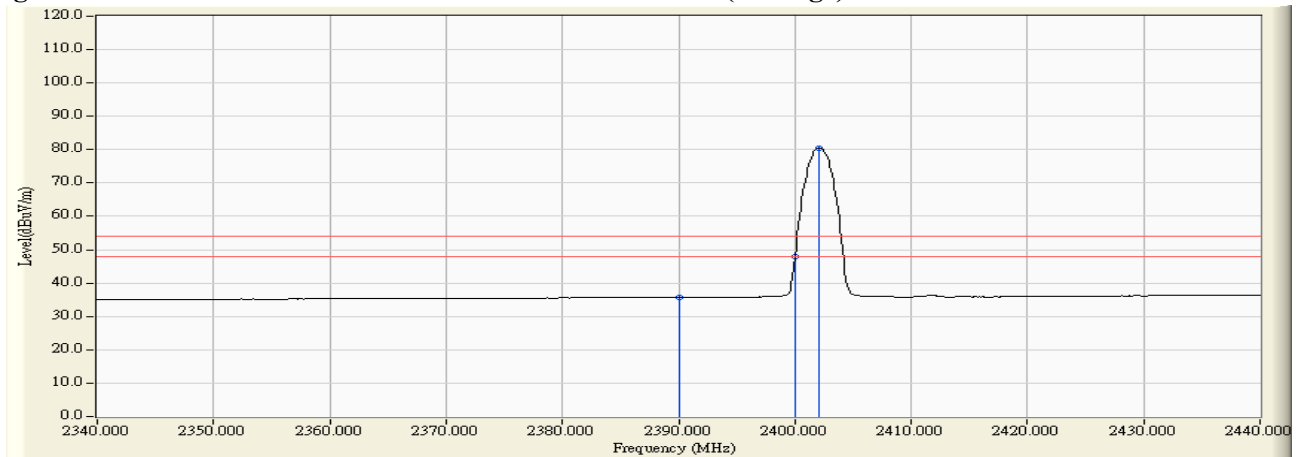

**Note:**

1. All readings above 1GHz are performed with peak and/or average measurements as necessary.
2. Peak measurements: RBW = 1MHz, VBW = 3 MHz, Sweep: Auto.
3. Average measurements: RBW = 1MHz, VBW = 10 Hz, Sweep: Auto.
4. “\*” , means this data is the worst emission level.
5. Measurement Level = Reading Level + Correct Factor.
6. The average measurement was not performed when the peak measured data under the limit of average detection.

Product : VoIP Phone  
 Test Item : Band Edge  
 Test Site : No.3 OATS  
 Test Mode : Mode 2: Transmit - 3Mbps (8DPSK)

**RF Radiated Measurement (Vertical):**

Channel No.	Frequency (MHz)	Correct Factor (dB)	Reading Level (dBμV)	Emission Level (dBμV/m)	Peak Limit (dBμV/m)	Average Limit (dBμV/m)	Result
00 (Peak)	2387.900	-4.152	52.422	48.270	74.00	54.00	Pass
00 (Peak)	2390.000	-4.159	49.631	45.472	74.00	54.00	Pass
00 (Peak)	2400.000	-4.171	58.458	54.287	--	--	--
00 (Peak)	2402.000	-4.171	92.627	88.456	--	--	--
00 (Average)	2390.000	-4.159	38.264	34.105	74.00	54.00	Pass
00 (Average)	2400.000	-4.171	46.599	42.428	--	--	--
00 (Average)	2402.100	-4.171	78.529	74.358	--	--	--

**Figure Channel 00: Vertical (Peak)**

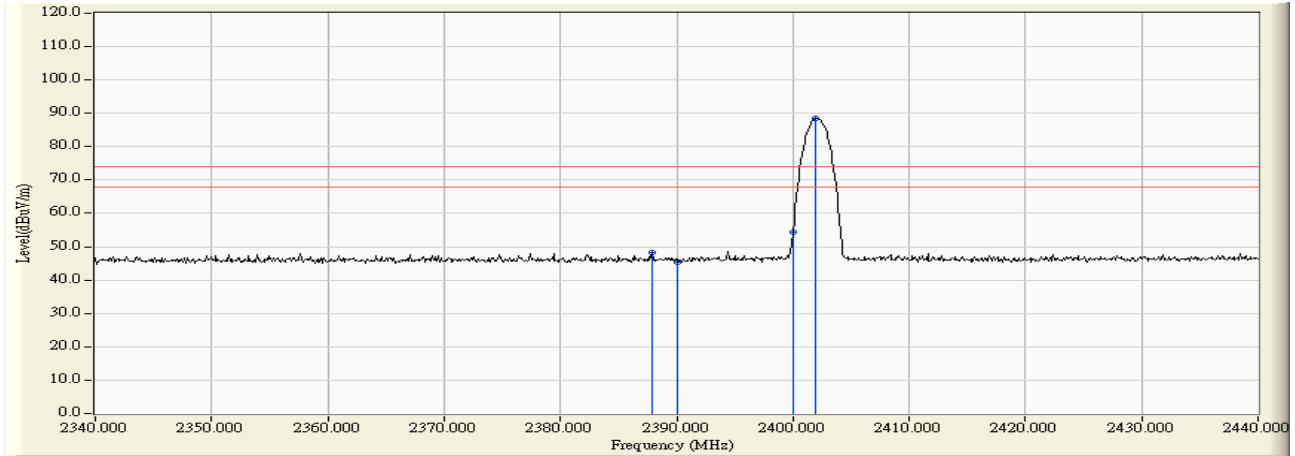

**Figure Channel 00: Vertical (Average)**

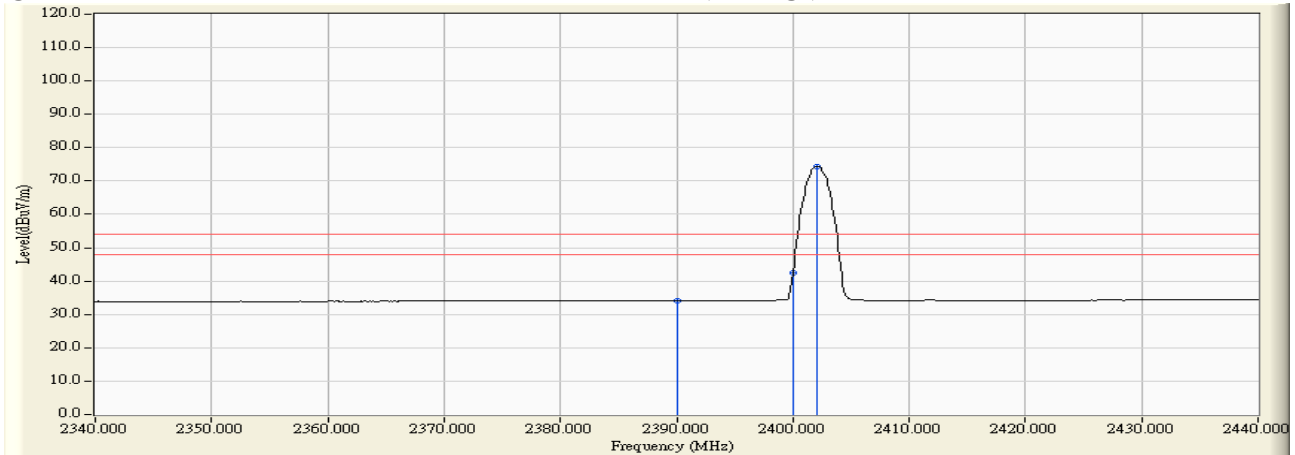

**Note:**

1. All readings above 1GHz are performed with peak and/or average measurements as necessary.
2. Peak measurements: RBW = 1MHz, VBW = 3 MHz, Sweep: Auto.
3. Average measurements: RBW = 1MHz, VBW = 10 Hz, Sweep: Auto.
4. “ \* ”, means this data is the worst emission level.
5. Measurement Level = Reading Level + Correct Factor.
6. The average measurement was not performed when the peak measured data under the limit of average detection.

Product : VoIP Phone  
 Test Item : Band Edge  
 Test Site : No.3 OATS  
 Test Mode : Mode 2: Transmit - 3Mbps (8DPSK)

**RF Radiated Measurement (Horizontal):**

Channel No.	Frequency (MHz)	Correct Factor (dB)	Reading Level (dBμV)	Emission Level (dBμV/m)	Peak Limit (dBμV/m)	Average Limit (dBμV/m)	Result
78 (Peak)	2480.000	-2.605	103.694	101.089	--	--	--
78 (Peak)	2483.500	-2.601	52.608	50.006	74.00	54.00	Pass
78 (Average)	2480.100	-2.605	87.392	84.787	--	--	--
78 (Average)	2483.500	-2.601	39.659	37.057	74.00	54.00	Pass

**Figure Channel 78: Horizontal (Peak)**

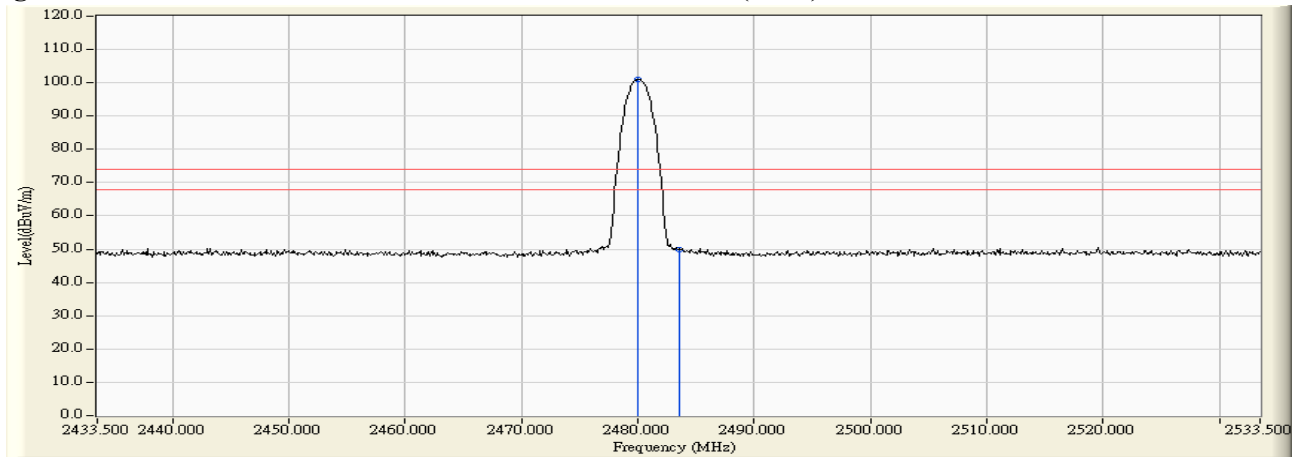

**Figure Channel 78: Horizontal (Average)**

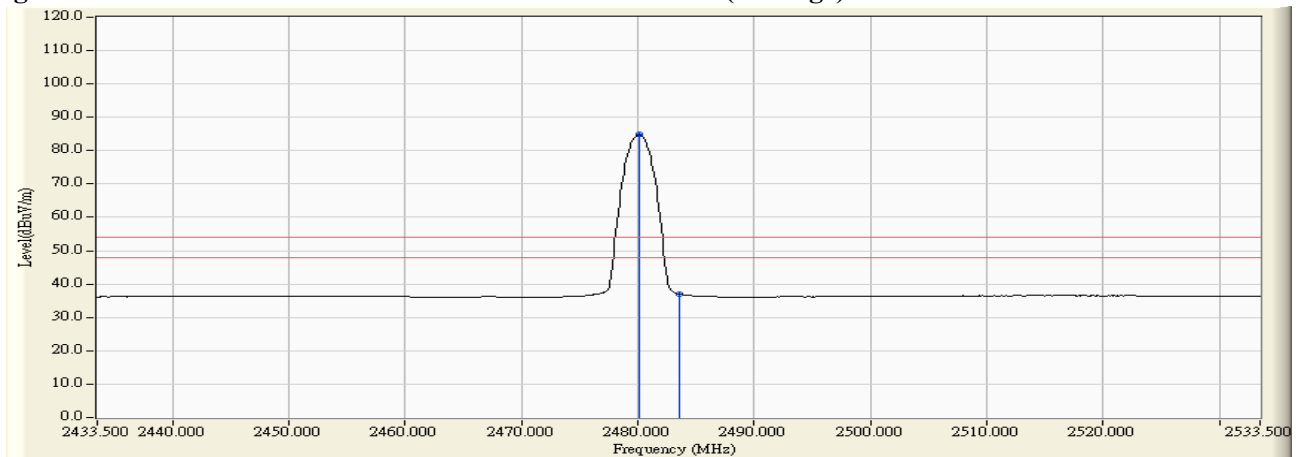

Note:

1. All readings above 1GHz are performed with peak and/or average measurements as necessary.
2. Peak measurements: RBW = 1MHz, VBW = 3 MHz, Sweep: Auto.
3. Average measurements: RBW = 1MHz, VBW = 10 Hz, Sweep: Auto.
4. “ \* ”, means this data is the worst emission level.
5. Measurement Level = Reading Level + Correct Factor.
6. The average measurement was not performed when the peak measured data under the limit of average detection.



Product : VoIP Phone  
 Test Item : Band Edge  
 Test Site : No.3 OATS  
 Test Mode : Mode 2: Transmit - 3Mbps (8DPSK)

**RF Radiated Measurement (Vertical):**

Channel No.	Frequency (MHz)	Correct Factor (dB)	Reading Level (dBμV)	Emission Level (dBμV/m)	Peak Limit (dBμV/m)	Average Limit (dBμV/m)	Result
78 (Peak)	2480.000	-3.978	96.270	92.292	--	--	--
78 (Peak)	2483.500	-3.966	50.162	46.195	74.00	54.00	Pass
78 (Peak)	2496.700	-3.924	52.204	48.280	74.00	54.00	Pass
78 (Average)	2480.100	-3.977	81.468	77.491	--	--	--
78 (Average)	2483.500	-3.966	38.510	34.543	74.00	54.00	Pass
78 (Average)	2510.200	-3.862	38.630	34.768	74.00	54.00	Pass

**Figure Channel 78: Vertical (Peak)**

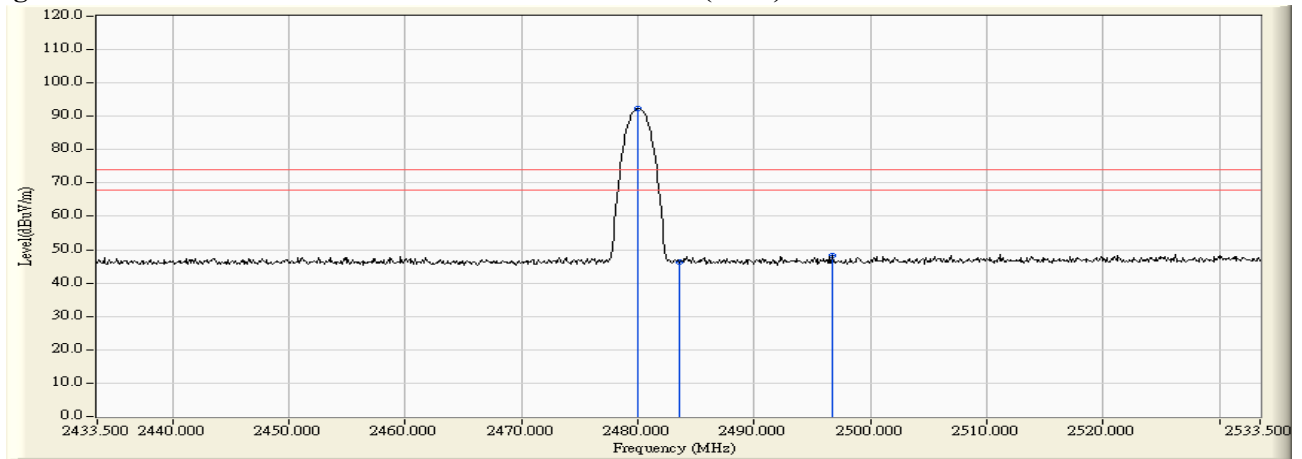

**Figure Channel 78: Vertical (Average)**

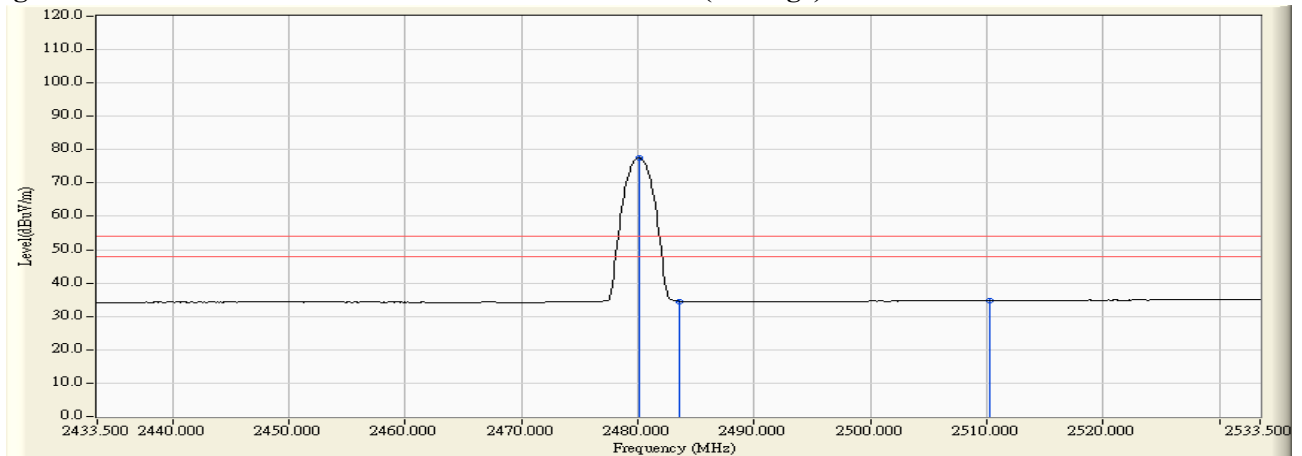

Note:

1. All readings above 1GHz are performed with peak and/or average measurements as necessary.
2. Peak measurements: RBW = 1MHz, VBW = 3 MHz, Sweep: Auto.
3. Average measurements: RBW = 1MHz, VBW = 10 Hz, Sweep: Auto.
4. “ \* ”, means this data is the worst emission level.
5. Measurement Level = Reading Level + Correct Factor.
6. The average measurement was not performed when the peak measured data under the limit of average detection.

**7. Channel Number**

**7.1. Test Equipment**

	Equipment	Manufacturer	Model No./Serial No.	Last Cal.
	Spectrum Analyzer	R&S	FSP40 / 100170	Jun, 2014
	Spectrum Analyzer	Agilent	E4407B / US39440758	Jun, 2014
X	Spectrum Analyzer	Agilent	N9010A / MY48030495	Apr., 2014

Note: 1. All equipments are calibrated every one year.  
 2. The test instruments marked by “X” are used to measure the final test results.

**7.2. Test Setup**

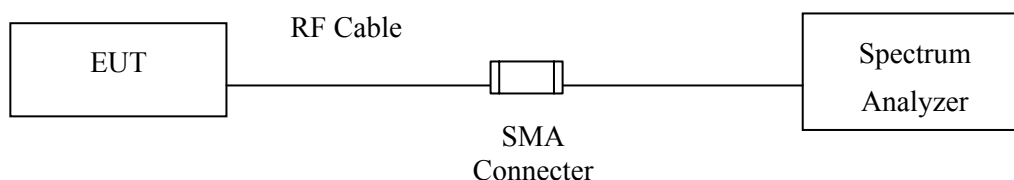

**7.3. Limit**

Frequency hopping systems operating in the 2400-2483.5 MHz bands shall use at least 75 hopping frequencies.

**7.4. Test Procedure**

The EUT was setup to ANSI C63.10, 2009; tested to FHSS test procedure of FCC Public Notice DA 00-705 for compliance to FCC 47CFR 15.247 requirements.

**7.5. Uncertainty**

N/A

7.6. Test Result of Channel Number

Product : VoIP Phone  
 Test Item : Channel Number  
 Test Site : No.3 OATS  
 Test Mode : Mode 1: Transmit - 1Mbps (GFSK)

Frequency Range (MHz)	Measurement (Hopping Channel)	Required Limit (Hopping Channel)	Result
2402 ~ 2480	79	>75	Pass

2402-2421MHz

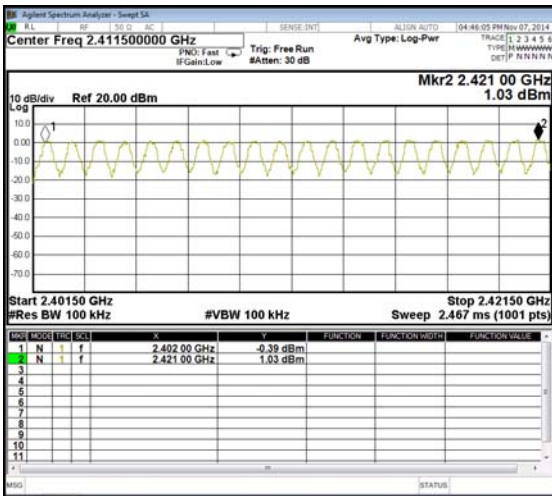

2422-2441MHz

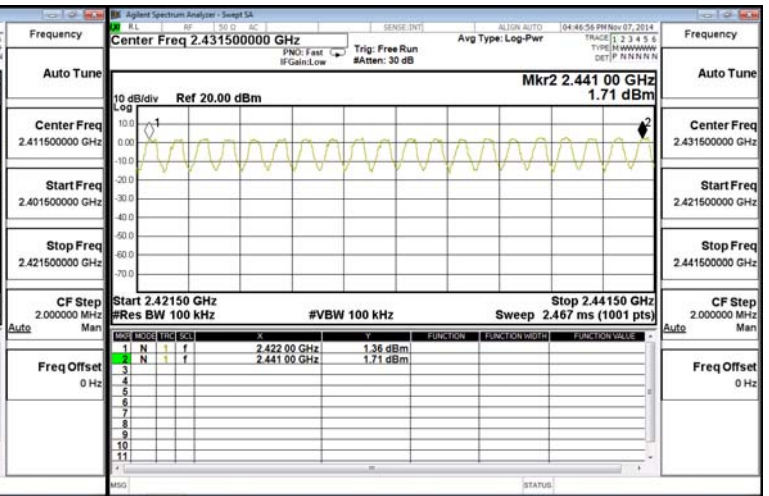

2442-2461MHz

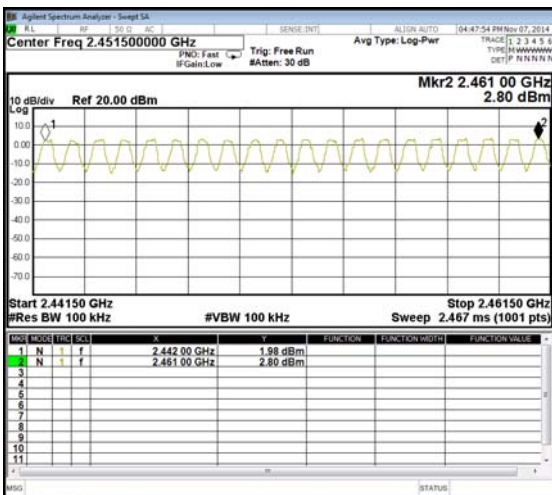

2462-2480MHz

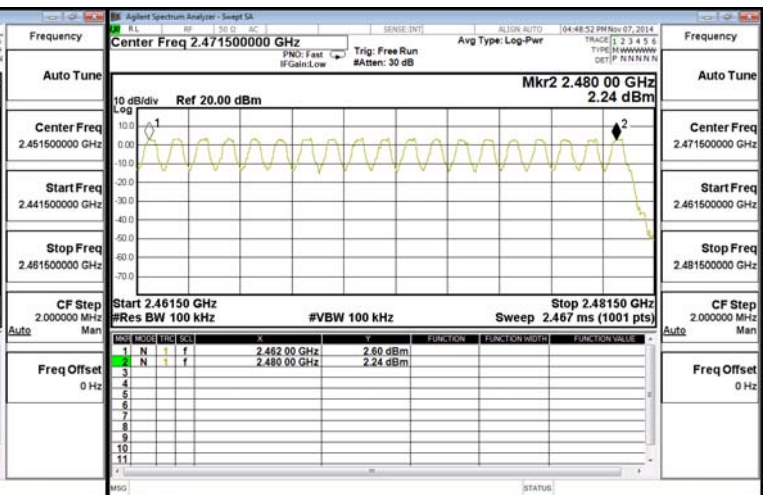

Product : VoIP Phone  
 Test Item : Channel Number  
 Test Site : No.3 OATS  
 Test Mode : Mode 2: Transmit - 3Mbps (8DPSK)

Frequency Range (MHz)	Measurement (Hopping Channel)	Required Limit (Hopping Channel)	Result
2402 ~ 2480	79	>75	Pass

2402-2421MHz

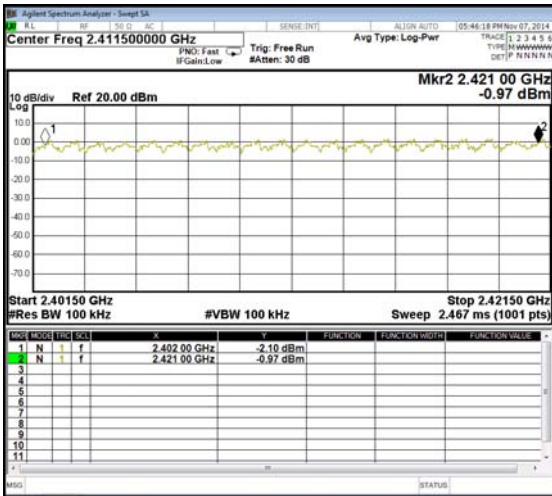

2422-2441MHz

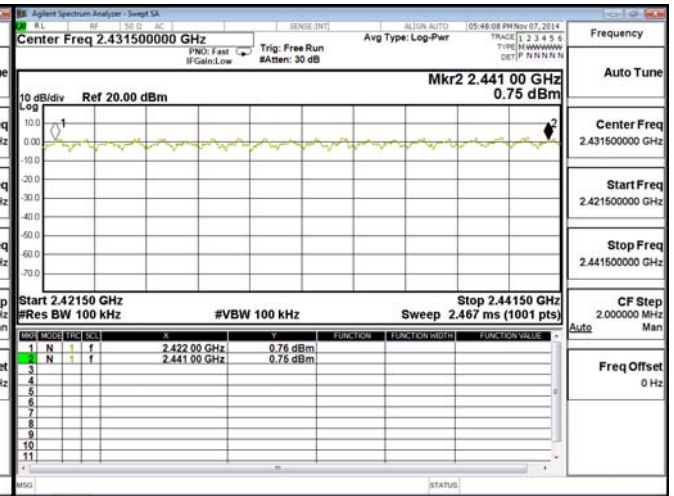

2442-2461MHz

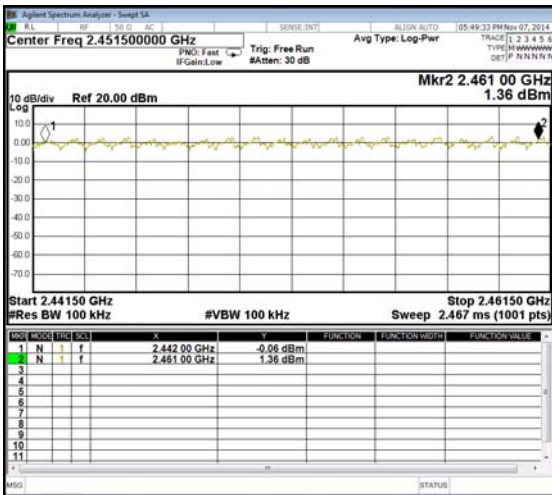

2462-2480MHz

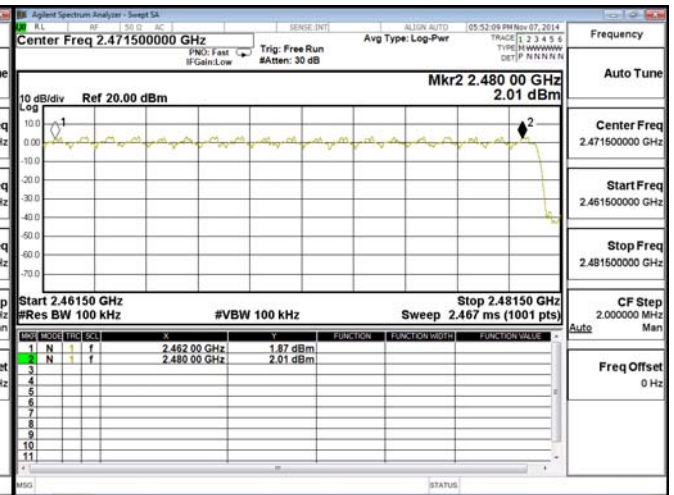

**8. Channel Separation**

**8.1. Test Equipment**

Equipment	Manufacturer	Model No./Serial No.	Last Cal.
Spectrum Analyzer	R&S	FSP40 / 100170	Jun, 2014
Spectrum Analyzer	Agilent	E4407B / US39440758	Jun, 2014
X Spectrum Analyzer	Agilent	N9010A / MY48030495	Apr., 2014

Note: 1. All equipments are calibrated every one year.  
 2. The test instruments mark by “X” are used to measure the final test results.

**8.2. Test Setup**

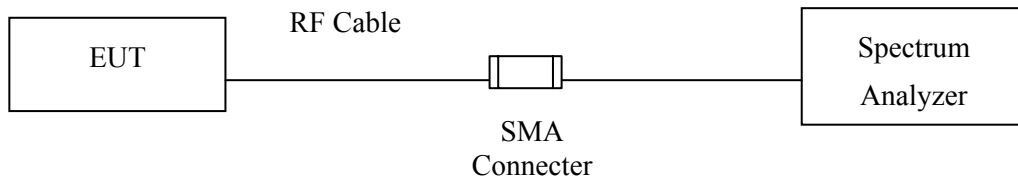

**8.3. Limit**

Frequency hopping systems shall have hopping channel carrier frequencies separated by a minimum of 25 kHz or the 20 dB bandwidth of the hopping channel, whichever is greater.

**8.4. Test Procedure**

The EUT was setup to ANSI C63.10, 2009; tested to FHSS test procedure of FCC Public Notice DA 00-705 for compliance to FCC 47CFR 15.247 requirements.

**8.5. Uncertainty**

± 150Hz

8.6. Test Result of Channel Separation

Product : VoIP Phone  
 Test Item : Channel Separation  
 Test Site : No.3 OATS  
 Test Mode : Mode 1: Transmit - 1Mbps (GFSK)

Channel No.	Frequency (MHz)	Measurement Level (kHz)	Limit (kHz)	Limit of (2/3)*20dB Bandwidth (kHz)	Result
00	2402	1000	>25 kHz	760.0	Pass
39	2441	1000	>25 kHz	753.3	Pass
78	2480	1000	>25 kHz	753.3	Pass

NOTE: The 20dB Bandwidth is refer to section 10.

Channel 00 2402MHz

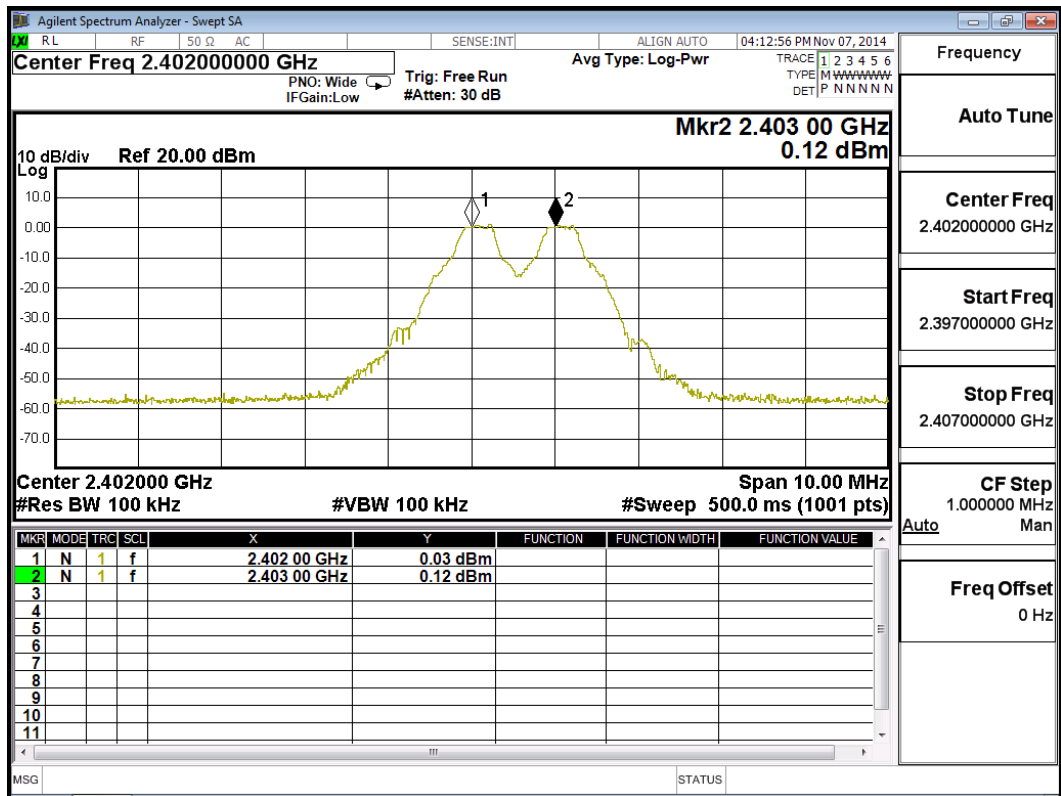

Channel 39 2441MHz

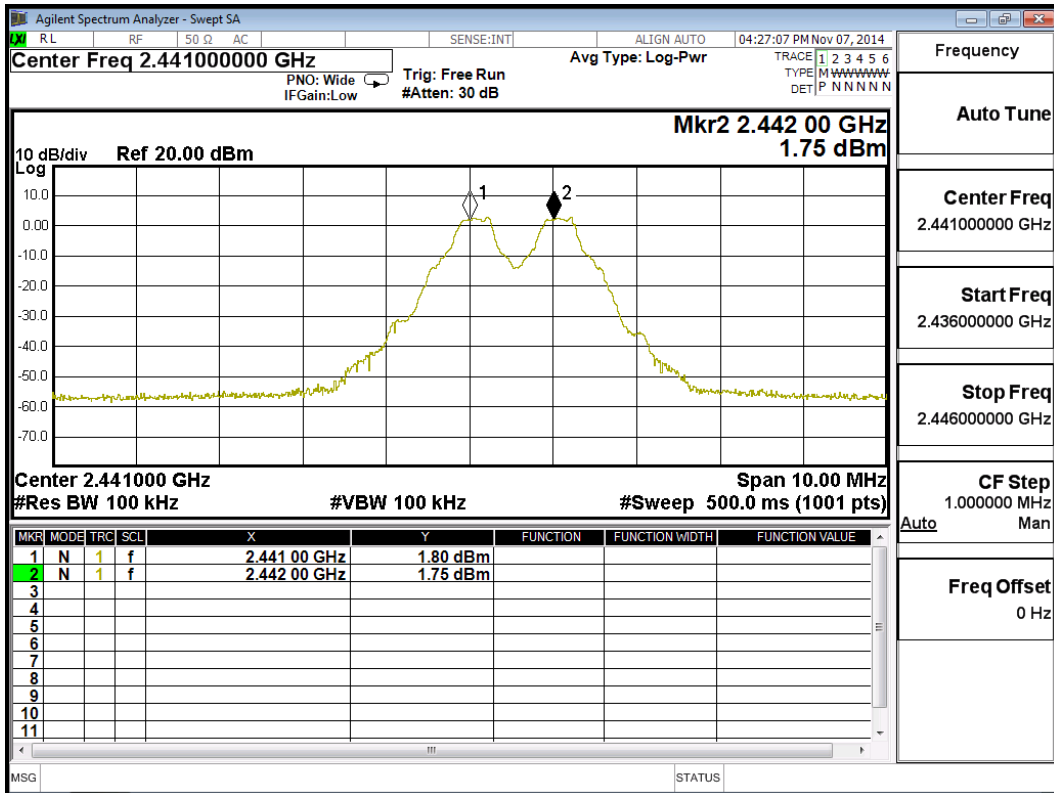

Channel 78 2480 MHz

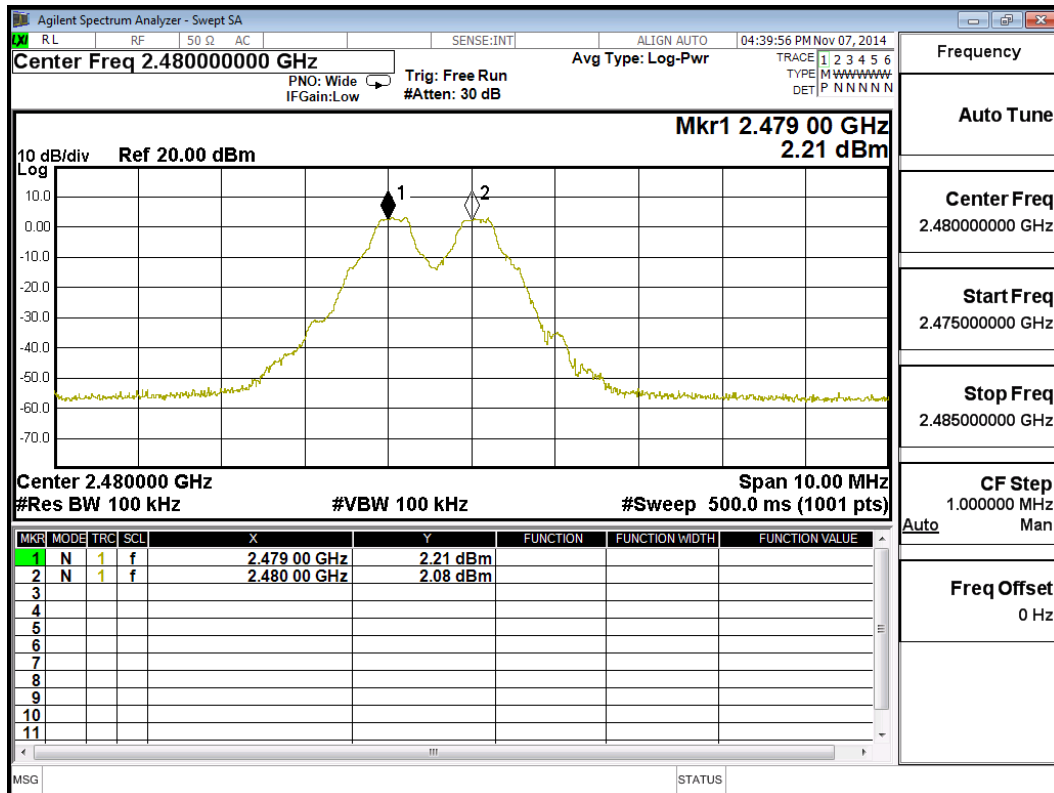

Product : VoIP Phone  
 Test Item : Channel Separation  
 Test Site : No.3 OATS  
 Test Mode : Mode 2: Transmit - 3Mbps (8DPSK)

Channel No.	Frequency (MHz)	Measurement Level (kHz)	Limit (kHz)	Limit of (2/3)*20dB Bandwidth (kHz)	Result
00	2402	1000	>25 kHz	946.7	Pass
39	2441	1000	>25 kHz	946.7	Pass
78	2480	1000	>25 kHz	946.7	Pass

NOTE: The 20dB Bandwidth is refer to section 10.

Channel 00 2402MHz

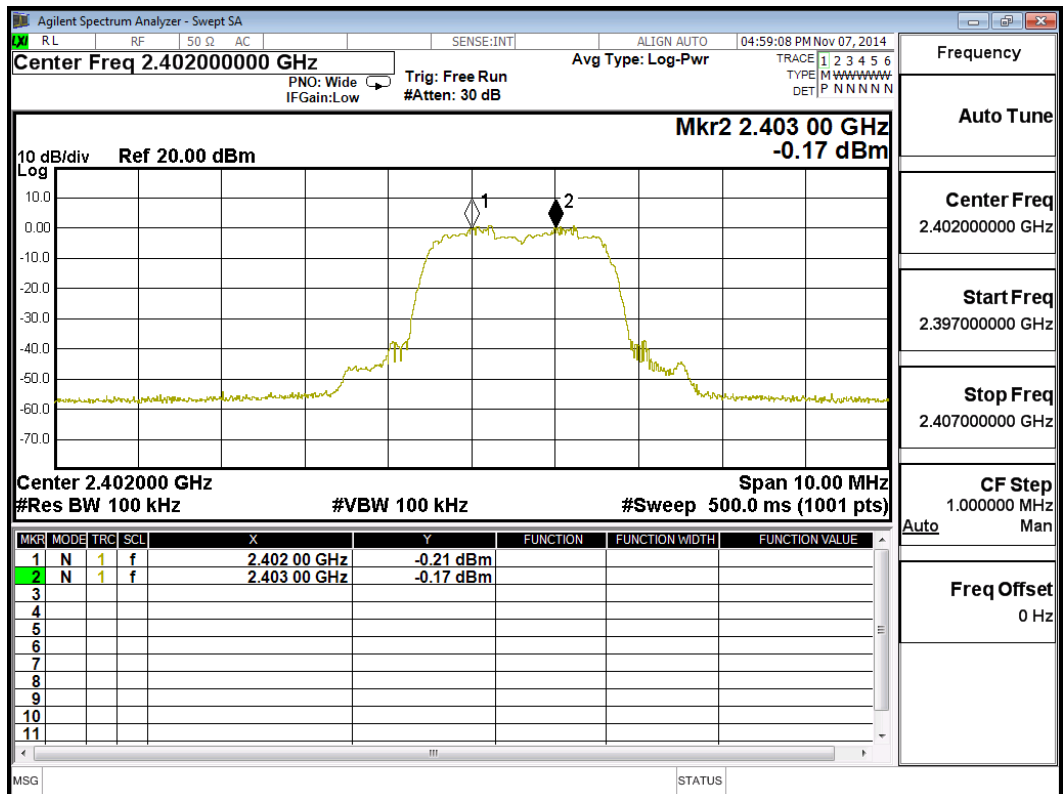



Channel 39 2441MHz

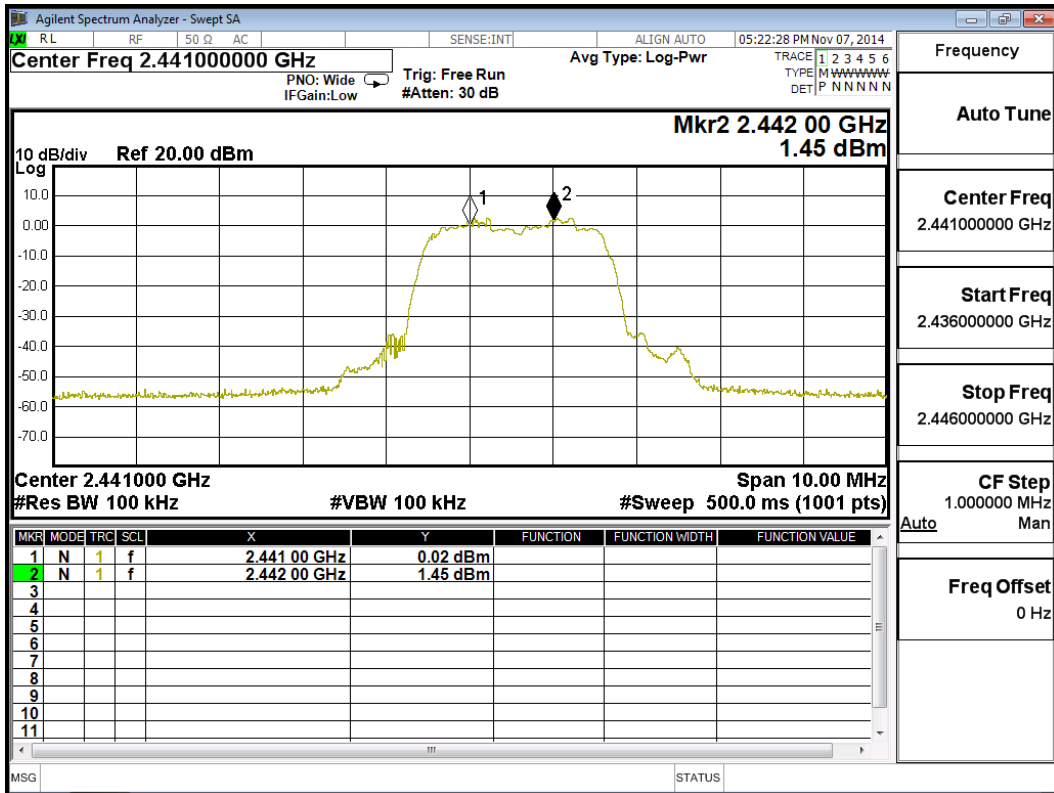

Channel 78 2480 MHz

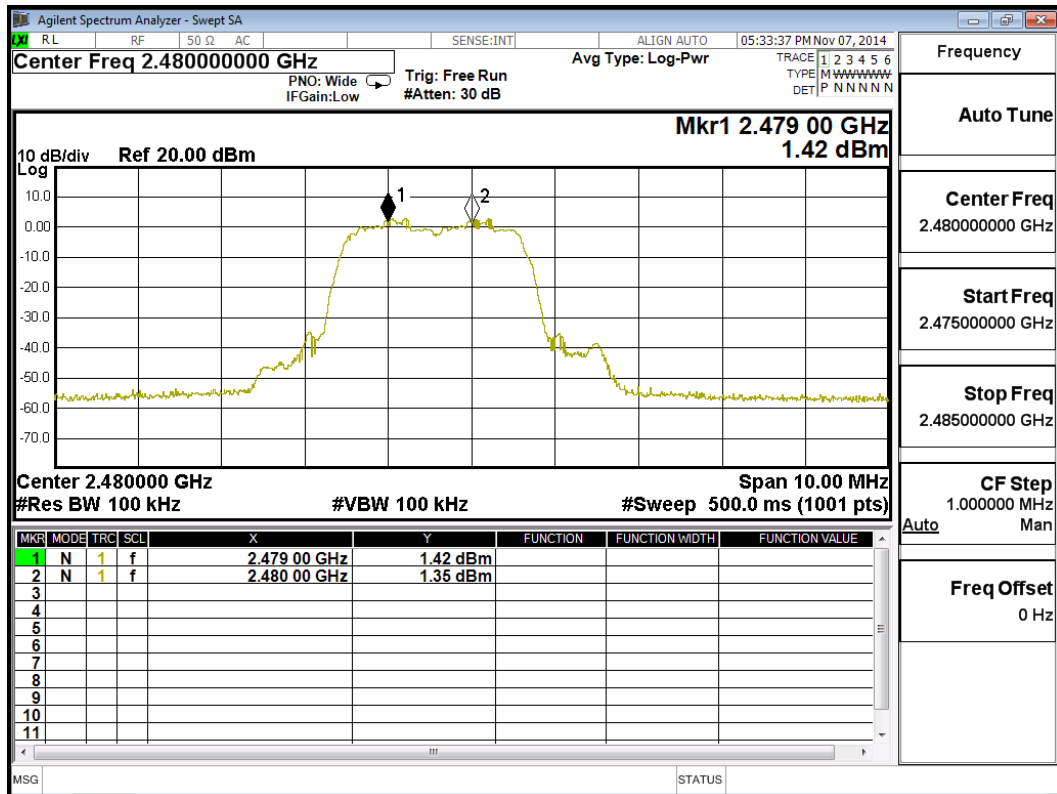

**9. Dwell Time**

**9.1. Test Equipment**

	Equipment	Manufacturer	Model No./Serial No.	Last Cal.
	Spectrum Analyzer	R&S	FSP40 / 100170	Jun, 2014
	Spectrum Analyzer	Agilent	E4407B / US39440758	Jun, 2014
X	Spectrum Analyzer	Agilent	N9010A / MY48030495	Apr., 2014

Note: 1. All equipments are calibrated every one year.  
 2. The test instruments marked by “X” are used to measure the final test results.

**9.2. Test Setup**

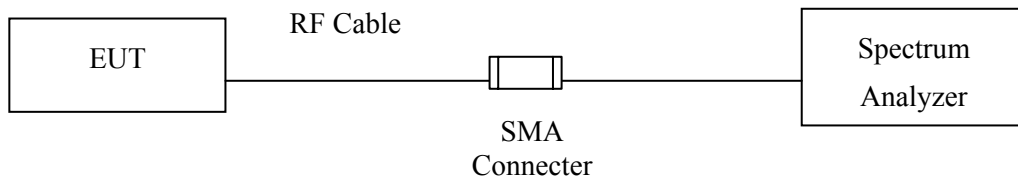

**9.3. Limit**

The dwell time shall be the average time of occupancy on any frequency shall not be greater than 0.4 seconds within a 30 second period.

**9.4. Test Procedure**

The EUT was setup to ANSI C63.10, 2009; tested to FHSS test procedure of FCC Public Notice DA 00-705 for compliance to FCC 47CFR 15.247 requirements.

**9.5. Uncertainty**

± 25msec

9.6. Test Result of Dwell Time

Product : VoIP Phone  
 Test Item : Dwell Time  
 Test Site : No.3 OATS  
 Test Mode : Mode 1: Transmit - 1Mbps (GFSK) (Channel 00,39,78 –DH5)

Frequency (MHz)	Time slot length (ms)	Hopping of Number	Sweep time (ms)	Duty cycle	Dwell Time (Sec)	Limit (Sec)	Result
2402	2.890	13	50	0.75	0.301	0.4	Pass
2441	2.880	13	50	0.75	0.300	0.4	Pass
2480	2.880	13	50	0.75	0.300	0.4	Pass

Duty cycle = ((Time slot length(ms)\*Hopping of Number) / Sweep time (ms))

Dwell time = (Duty cycle / 79) \* (79\*0.4)

CH 00 Time Interval between hops

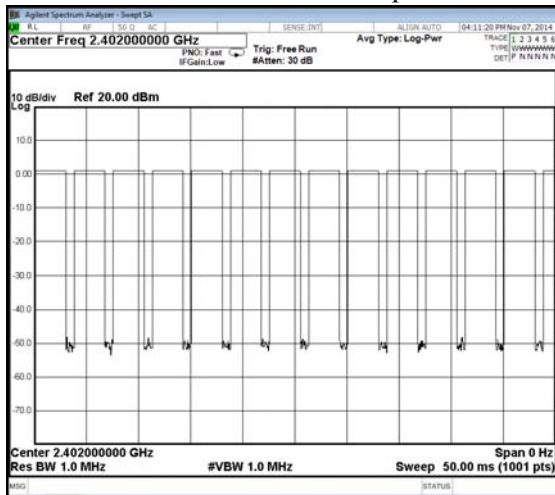

CH 00 Transmission Time

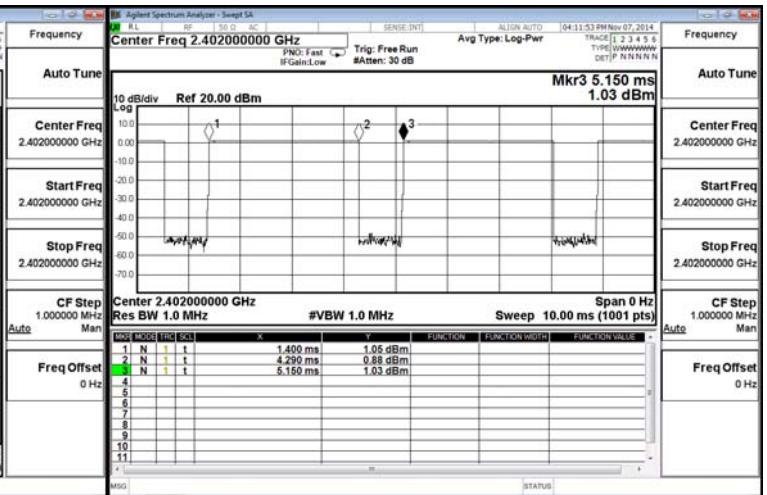

CH39 Time Interval between hops

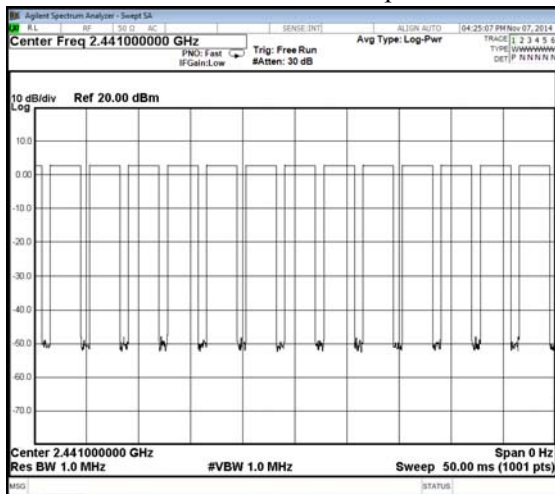

CH 39 Transmission Time

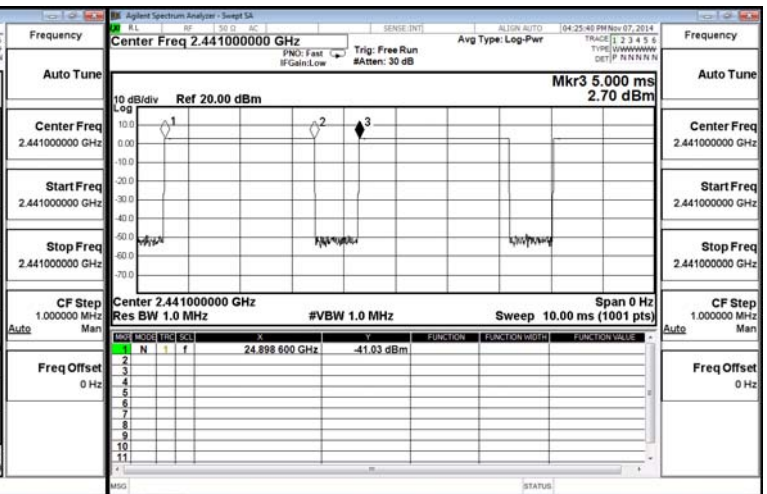

CH 78 Time Interval between hops

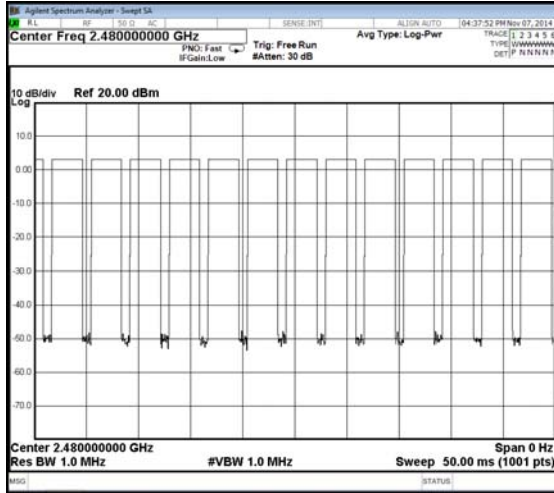

CH 78 Transmission Time

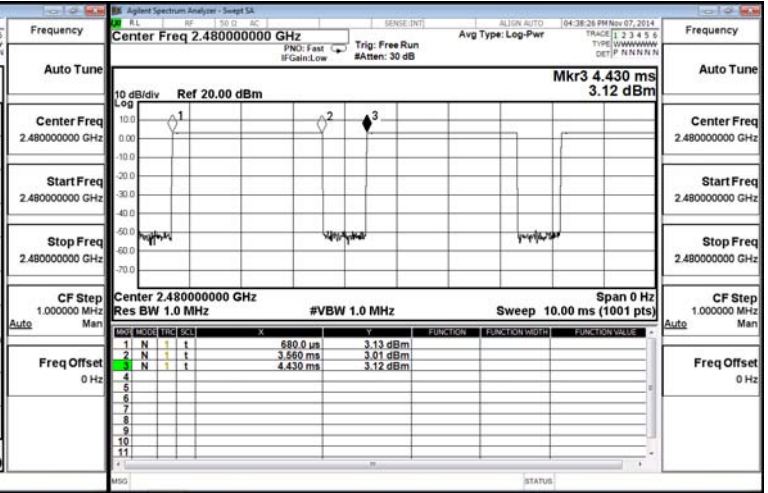

Note:

The dwell times of the packet type of DH1, DH3, and DH5 are tested. Only the worst case is shown on the report.

Product : VoIP Phone  
 Test Item : Dwell Time  
 Test Site : No.3 OATS  
 Test Mode : Mode 2: Transmit - 3Mbps (8DPSK) (Channel 00,39,78 –DH5)

Frequency (MHz)	Time slot length (ms)	Hopping of Number	Sweep time (ms)	Duty cycle	Dwell Time (Sec)	Limit (Sec)	Result
2402	2.890	13	50	0.75	0.301	0.4	Pass
2441	2.890	13	50	0.75	0.301	0.4	Pass
2480	2.890	13	50	0.75	0.301	0.4	Pass

Duty cycle = ((Time slot length(ms)\*Hopping of Number) / Sweep time (ms))

Dwell time = (Duty cycle / 79) \* (79\*0.4)

CH 00 Time Interval between hops

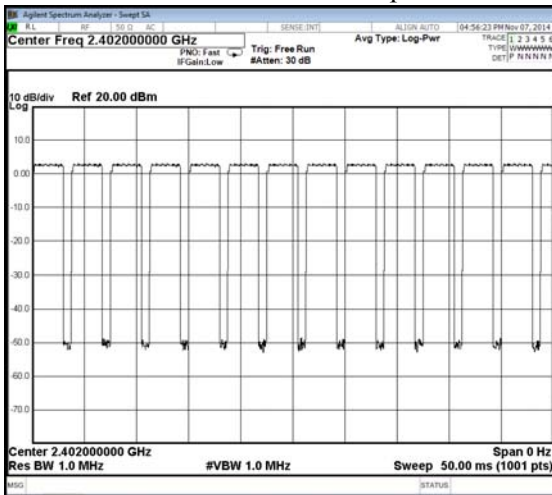

CH 00 Transmission Time

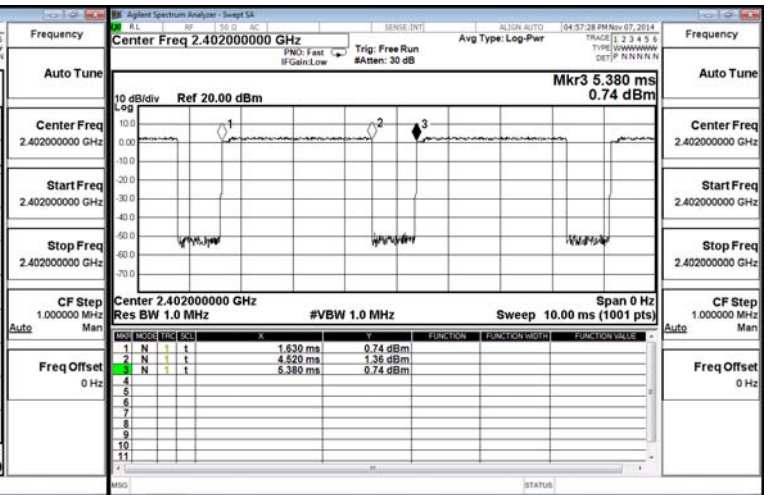

CH39 Time Interval between hops

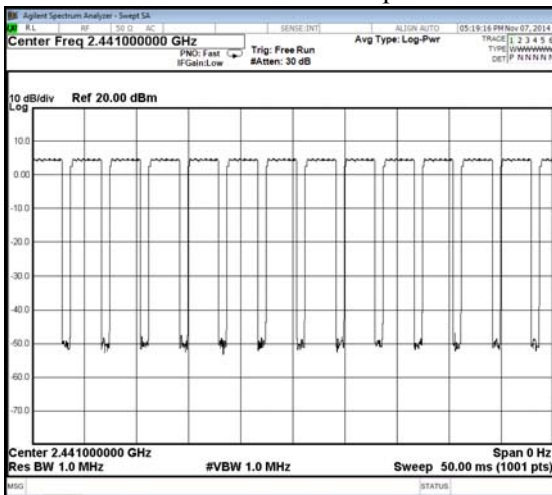

CH 39 Transmission Time

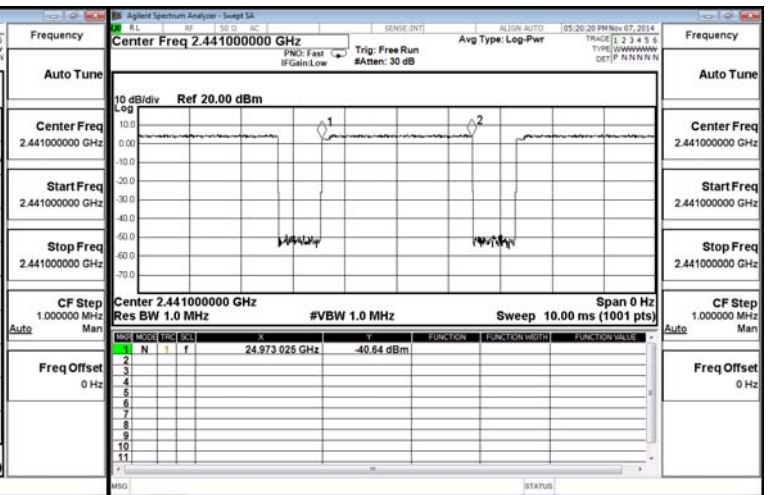

CH 78 Time Interval between hops

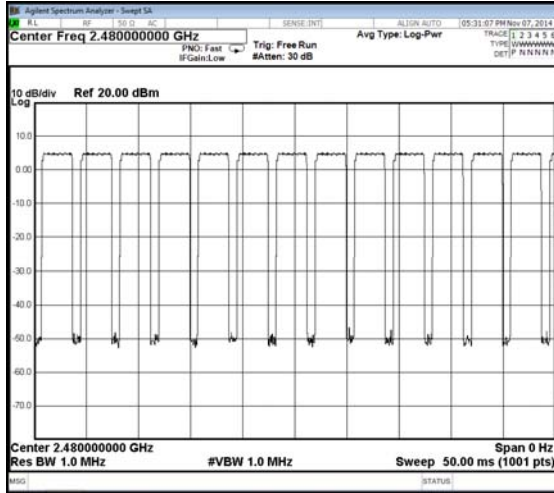

CH 78 Transmission Time

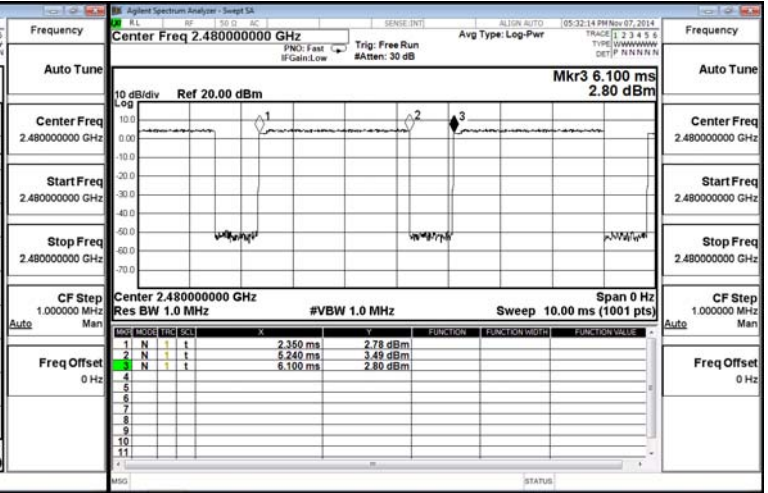

Note:

The dwell times of the packet type of DH1, DH3, and DH5 are tested. Only the worst case is shown on the report.

**10. Occupied Bandwidth**

**10.1. Test Equipment**

	Equipment	Manufacturer	Model No./Serial No.	Last Cal.
	Spectrum Analyzer	R&S	FSP40 / 100170	Jun, 2014
	Spectrum Analyzer	Agilent	E4407B / US39440758	Jun, 2014
X	Spectrum Analyzer	Agilent	N9010A / MY48030495	Apr., 2014

Note: 1. All equipments are calibrated every one year.  
 2. The test instruments marked by “X” are used to measure the final test results.

**10.2. Test Setup**

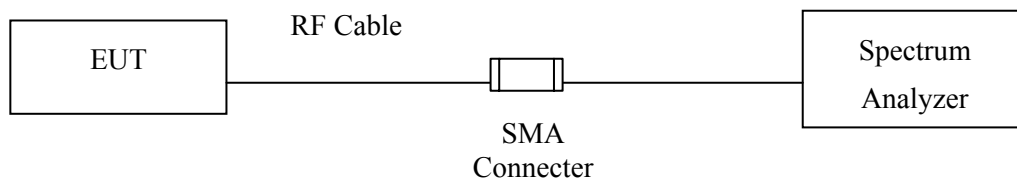

**10.3. Limits**

N/A

**10.4. Test Procedure**

The EUT was setup to ANSI C63.10, 2009; tested to FHSS test procedure of FCC Public Notice DA 00-705 for compliance to FCC 47CFR 15.247 requirements.

**10.5. Uncertainty**

± 150Hz

10.6. Test Result of Occupied Bandwidth

Product : VoIP Phone  
 Test Item : Occupied Bandwidth Data  
 Test Site : No.3 OATS  
 Test Mode : Mode 1: Transmit - 1Mbps (GFSK)(2402MHz)

Channel No.	Frequency (MHz)	Measurement Level (kHz)	Required Limit (kHz)	Result
00	2402	1140	--	NA

Figure Channel 00:

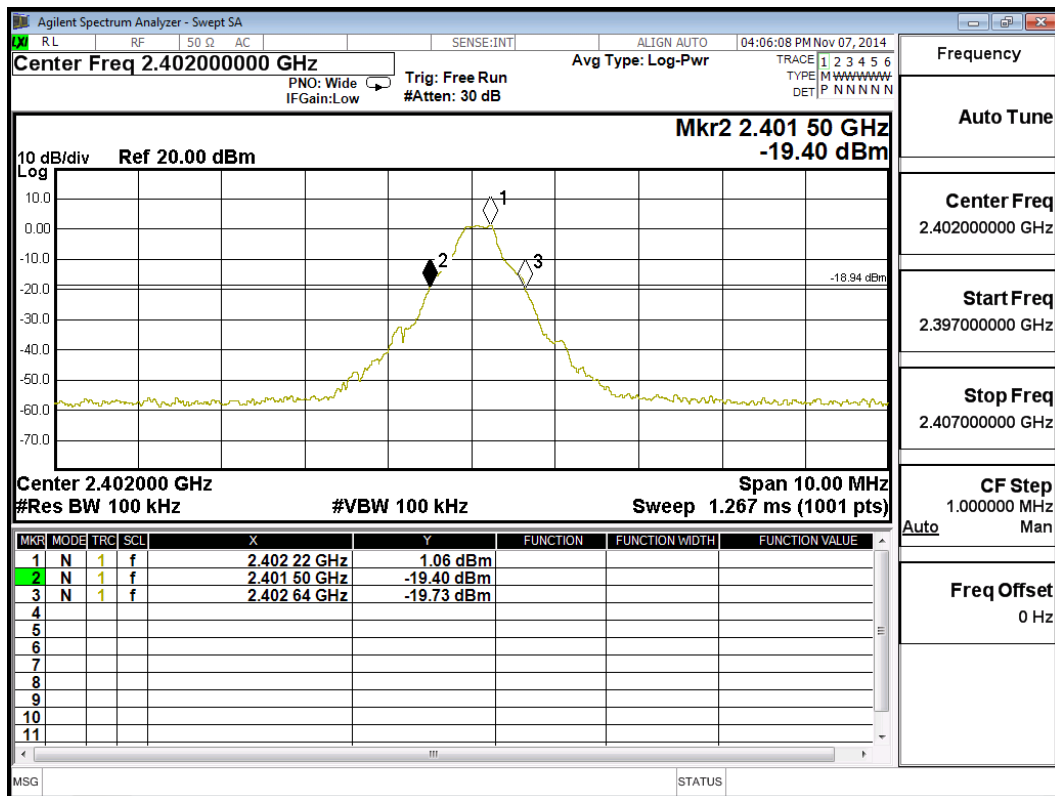



Product : VoIP Phone  
 Test Item : Occupied Bandwidth Data  
 Test Site : No.3 OATS  
 Test Mode : Mode 1: Transmit - 1Mbps (GFSK)(2441MHz)

Channel No.	Frequency (MHz)	Measurement Level (kHz)	Required Limit (kHz)	Result
39	2441	1130	--	NA

Figure Channel 39:

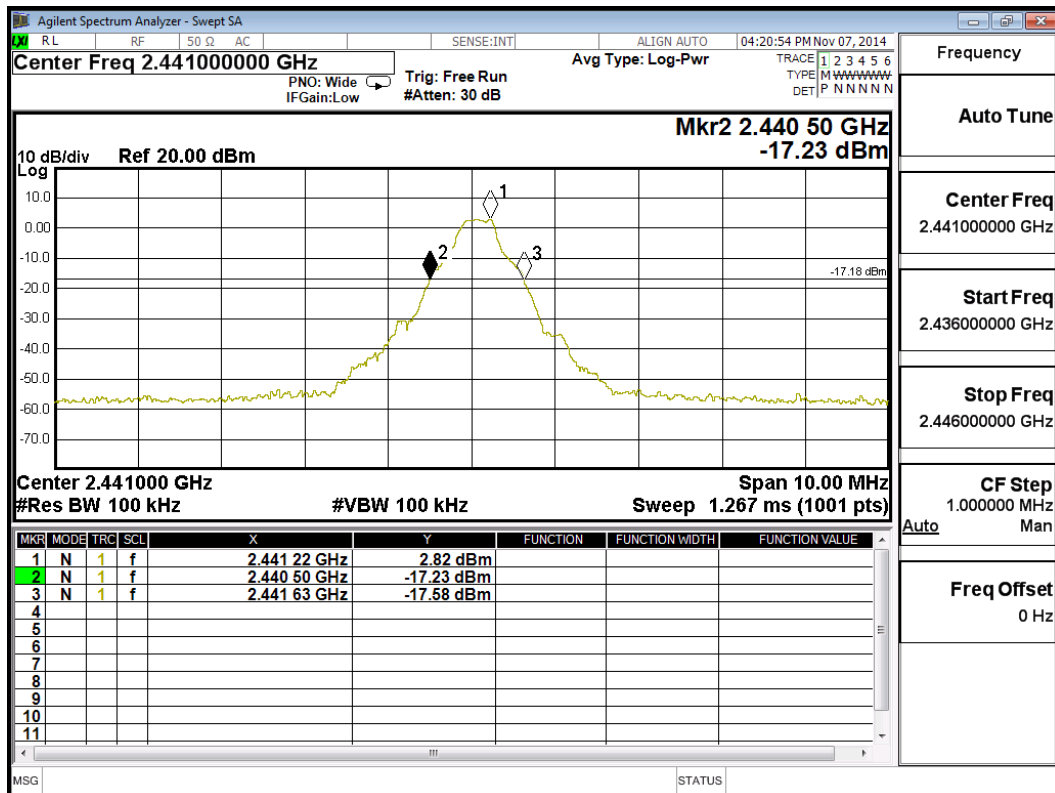

Product : VoIP Phone  
 Test Item : Occupied Bandwidth Data  
 Test Site : No.3 OATS  
 Test Mode : Mode 1: Transmit - 1Mbps (GFSK)(2480MHz)

Channel No.	Frequency (MHz)	Measurement Level (kHz)	Required Limit (kHz)	Result
78	2480	1130	--	NA

Figure Channel 78:

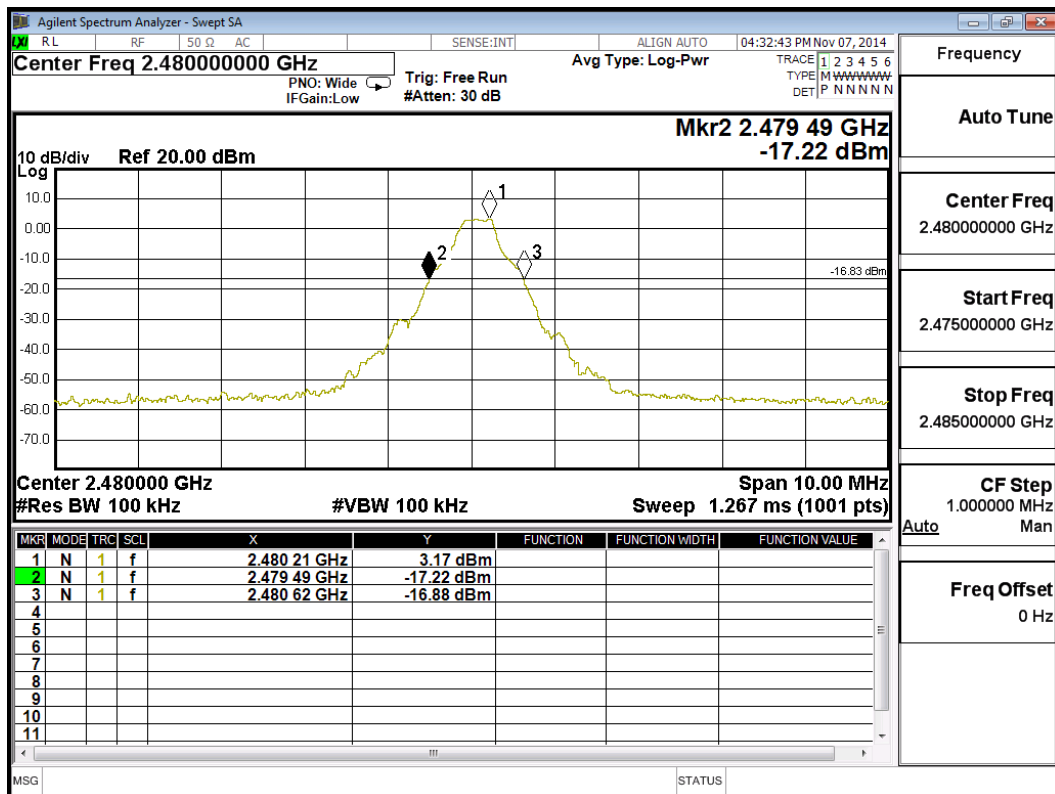

Product : VoIP Phone  
 Test Item : Occupied Bandwidth Data  
 Test Site : No.3 OATS  
 Test Mode : Mode 2: Transmit - 3Mbps (8DPSK) (2402MHz)

Channel No.	Frequency (MHz)	Measurement Level (kHz)	Required Limit (kHz)	Result
00	2402	1420	--	NA

Figure Channel 00:

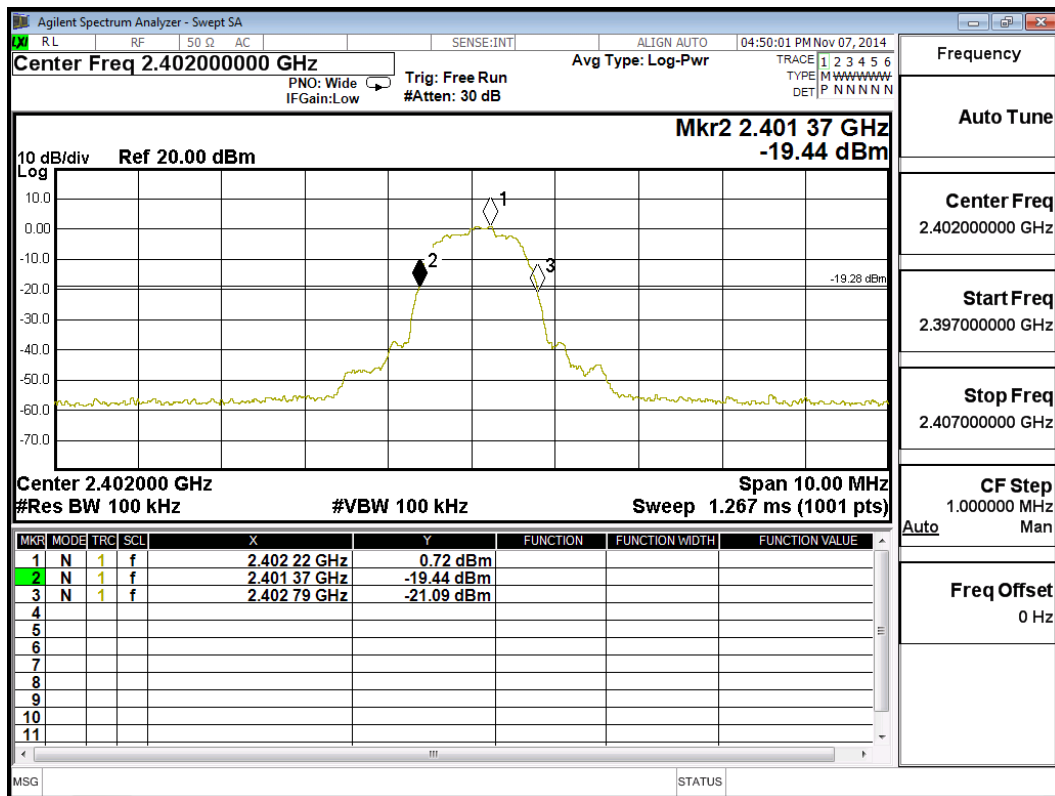

Product : VoIP Phone  
 Test Item : Occupied Bandwidth Data  
 Test Site : No.3 OATS  
 Test Mode : Mode 2: Transmit - 3Mbps (8DPSK) (2441MHz)

Channel No.	Frequency (MHz)	Measurement Level (kHz)	Required Limit (kHz)	Result
39	2441	1420	--	NA

Figure Channel 39:

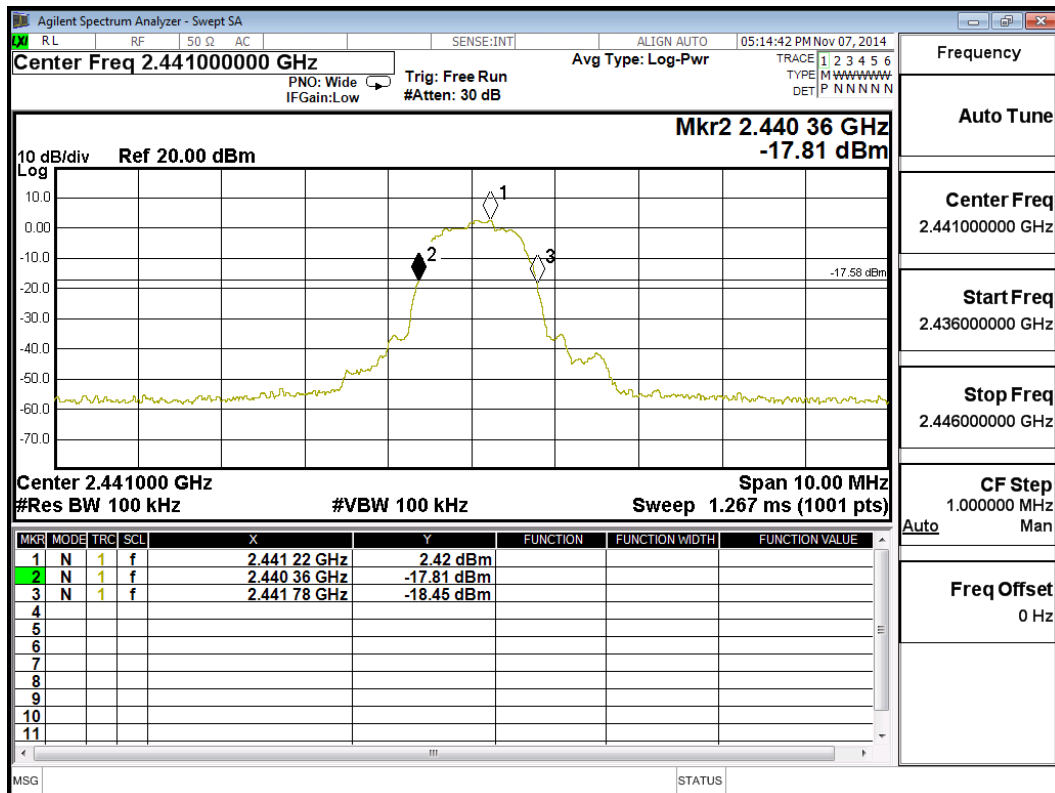

Product : VoIP Phone  
 Test Item : Occupied Bandwidth Data  
 Test Site : No.3 OATS  
 Test Mode : Mode 2: Transmit - 3Mbps (8DPSK)(2480MHz)

Channel No.	Frequency (MHz)	Measurement Level (kHz)	Required Limit (kHz)	Result
78	2480	1420	--	NA

Figure Channel 78:

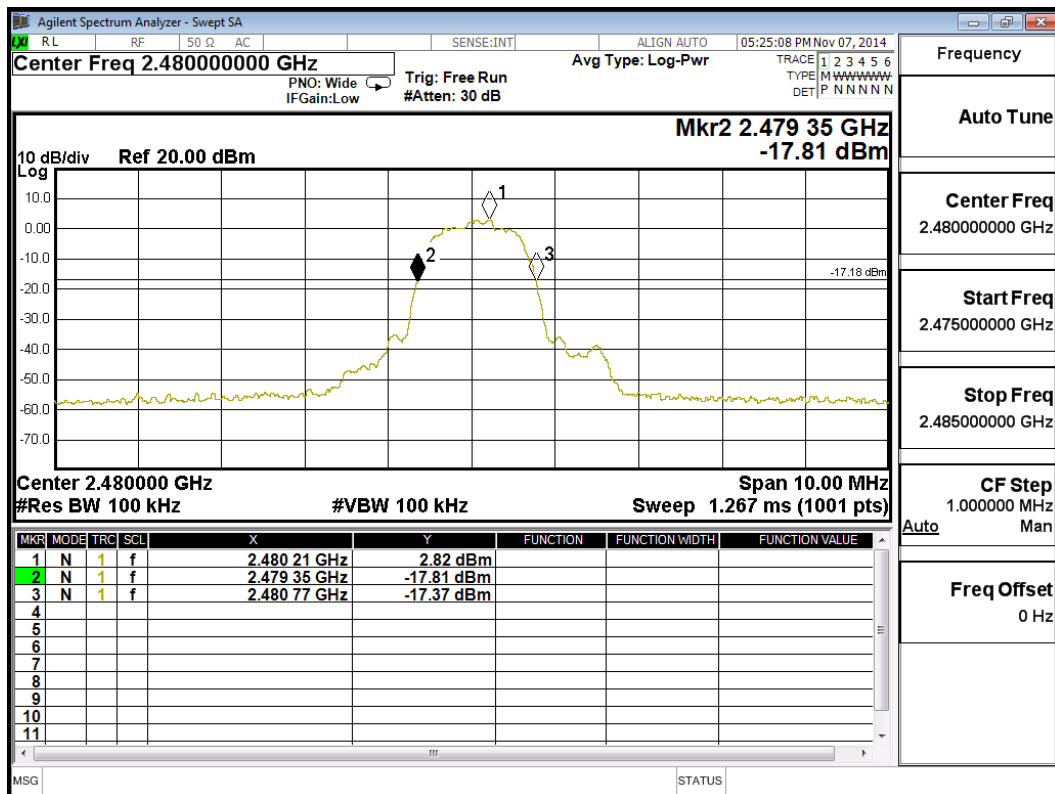

**11. EMI Reduction Method During Compliance Testing**

No modification was made during testing.

Attachment 1: EUT Test Photographs

Attachment 2: EUT Detailed Photographs