



FCC RADIO TEST REPORT

Applicant : Ubiquiti Inc.
Address : 685 Third Avenue, New York, New York 10017, USA
Equipment : UniFi Access Ultra
Model No. : UA-Ultra
Trade Name : UBIQUITI
FCC ID : SWX-UAU

I HEREBY CERTIFY THAT :

The sample was received on Nov. 28, 2023 and the testing was completed on Dec. 19, 2023 at CerpPASS Technology Corp. The test result refers exclusively to the test presented test model / sample. Without written approval of CerpPASS Technology Corp., the test report shall not be reproduced except in full.

Approved by:

Mark Liao / Supervisor

Laboratory Accreditation:

CerpPASS Technology Corporation Test Laboratory





Contents

1. Summary of Test Procedure and Test Results	4
1.1. Applicable Standards	4
2. Test Configuration of Equipment under Test	5
2.1. Feature of Equipment under Test	5
2.2. Carrier Frequency of Channels	5
2.3. Test Mode and Test Software	6
2.4. Description of Test System	7
2.5. General Information of Test	8
2.6. Measurement Uncertainty	8
3. Test Equipment and Ancillaries Used for Tests	9
4. Antenna Requirements	11
4.1. Standard Applicable	11
4.2. Antenna Construction and Directional Gain	11
5. Test of AC Power Line Conducted Emission	12
5.1. Test Limit	12
5.2. Test Procedures	12
5.3. Typical Test Setup	13
5.4. Test Result and Data	14
5.5. Test Photographs	16
6. Test of Radiated Emission	17
6.1. Test Limit	17
6.2. Test Procedures	18
6.3. Typical Test Setup Layout of Radiated Emission	19
6.4. Test Result and Data	20
6.5. 20dB Bandwidth	26
6.6. Test Photographs (9kHz ~ 30MHz)	27
6.7. Test Photographs (30MHz ~ 1GHz)	28
7. Frequency Stability	29
7.1. Test Procedure	29
7.2. Test Setup Layout	29
7.3. Test Result and Data	30
8. Radio Frequency Exposure	31
8.1. Applicable Standards	31
8.2. EUT Specification	32
8.3. Test Results	32



1. Summary of Test Procedure and Test Results

1.1. Applicable Standards

ANSI C63.10:2013

FCC Rules and Regulations Part 15 Subpart C §15.225

FCC Rule	Description of Test	Result
15.203	Antenna Requirement	PASS
15.207	AC Power Line Conducted Emission	PASS
15.209 15.225	Radiated Emission	PASS
15.225	20dB Bandwidth	PASS
15.225(e)	Frequency Stability	PASS

*The lab has reduced the uncertainty risk factor from test equipment, environment and staff technicians which according to the standard on contract. Therefore, the test result will only be determined by standard requirement, measurement uncertainty evaluation is not considered.



2. Test Configuration of Equipment under Test

2.1. Feature of Equipment under Test

Operation Frequency Range	NFC: 13.553MHz ~ 13.567MHz BLE: 2400MHz ~ 2483.5MHz
Center Frequency Range	NFC: 13.56MHz BLE: 2402MHz ~ 2480MHz
Modulation Type	NFC: ASK BLE: GFSK
Modulation Technology	BLE: DTS
Data Rate	BLE: 1Mbps
Antenna Type	NFC: Loop ANT BLE: PIFA ANT
Antenna Gain	NFC: 0 dBi BLE: 4 dBi

Note: For more details, please refer to the User’s manual of the EUT.

2.2. Carrier Frequency of Channels

Channel	Frequency(MHz)
*1	13.56

Note: Channel remarked “*” is selected to perform test.



2.3. Test Mode and Test Software

- a. During testing, the interface cables and equipment positions were varied according to ANSI C63.10.
- b. Hardware control was executed to transmit and receive data via NFC.
- c. The following test modes were performed for the test:

Conducted Emissions from the AC mains power ports	
Test Mode 1	TX Mode, Power from PoE (AC 120V/60Hz)
Test Mode 2	TX Mode, Power from PoE (AC 240V/60Hz)
caused "Test Mode 1" generated the worst case, it was reported as the final data.	
Radiation Emissions (9kHz ~ 30MHz)	
Test Mode 1	NFC-A ISO14443A, TX Mode, Power from PoE (AC 120V/60Hz)
Test Mode 2	NFC-B ISO14443B, TX Mode, Power from PoE (AC 120V/60Hz)
Test Mode 3	NFC-F Felica, TX Mode, Power from PoE (AC 120V/60Hz)
Test Mode 4	NFC-V ISO15693, TX Mode, Power from PoE (AC 120V/60Hz)
caused "Test Mode 1" generated the worst case, it was reported as the final data.	
Radiation Emissions (30MHz ~ 1GHz)	
Test Mode 1	TX Mode, Power from PoE (AC 120V/60Hz)
Test Mode 2	TX Mode, Power from PoE (AC 240V/60Hz)
caused "Test Mode 2" generated the worst case, it was reported as the final data.	



2.4. Description of Test System

Frequency Stability				
Equipment	Brand	Model	Length/Type	Power cord/ Length/Type
NFC Card	Tiananxin	NFC Tag Kit	N/A	N/A
RJ45 Cable	TE CONNECTIVITY	CAT5E	1.2m / NS	N/A
PoE	UBIQUITI	GP-V480-032G	N/A	N/A

Radiated Emissions				
Equipment	Brand	Model	Length/Type	Power cord/ Length/Type
NFC Card	Tiananxin	NFC Tag Kit	N/A	N/A
RJ45 Cable	TE CONNECTIVITY	CAT5E	15m / NS	N/A
PoE	UBIQUITI	GP-V480-032G	N/A	N/A

AC Power Line Conducted Emission				
Equipment	Brand	Model	Length/Type	Power cord/ Length/Type
NFC Card	Tiananxin	NFC Tag Kit	N/A	N/A
RJ45 Cable	TE CONNECTIVITY	CAT5E	1.2m / NS	N/A
PoE	UBIQUITI	GP-V480-032G	N/A	N/A



2.5. General Information of Test

Test Site	CerpPASS Technology Corporation Test Laboratory Address: No.10, Ln. 2, Lianfu St., Luzhu Dist., Taoyuan City 33848, Taiwan (R.O.C.) Tel:+886-3-3226-888 Fax:+886-3-3226-881	
	FCC	TW1439, TW1079
	IC	4934E-1, 4934E-2
Frequency Range Investigated:	Conducted: from 150kHz to 30 MHz Radiation: from 30 MHz to 1,000MHz	
Test Distance:	The test distance of radiated emission from antenna to EUT is 3 M.	

Test Item	Test Site	Test period	Environmental Conditions	Tested By
Frequency Stability	RFCON01-NK	2023/12/14 ~ 2023/12/15	25~27°C / 42~45%	Leon Huang
Radiated Emissions	3M02-NK	2023/12/11 ~ 2023/12/19	21~23°C / 51~56%	Leon Huang
AC Power Line Conducted Emission	CON02-NK	2023/12/15	21°C / 58%	Leon Huang

2.6. Measurement Uncertainty

ISO/IEC 17025 requires that an estimate of the measurement uncertainties associated with the emissions test results be included in the report. The measurement uncertainties given below are based on a 95% confidence level (based on a coverage factor (k=2))

Measurement Item	Uncertainty
Radiated Spurious Emission(9KHz~30MHz)	±3.5dB
Radiated Spurious Emission(30MHz~1GHz)	±5.1dB
20dB Bandwidth	±4.4%
Occupied Bandwidth	±4.5%
Frequency Stability	±0.23KHz



3. Test Equipment and Ancillaries Used for Tests

Test Item	Radiated Emissions				
Test Site	Semi Anechoic Room(3M02-NK)				
Instrument	Manufacturer	Model No	Serial No	Calibration Date	Valid Date
Bilog Antenna	Schwarzbeck	VULB9168	369	2023/03/15	2024/03/14
Active Loop Antenna	Schwarzbeck	FMZB 1513	414	2023/02/03	2024/02/02
Horn Antenna	EMCO	3115	31589	2023/03/23	2024/03/22
Horn Antenna	EMCO	3116	31970	2023/03/03	2024/03/02
EMI Receiver	R&S	ESCI	101423	2023/07/05	2024/07/04
Spectrum Analyzer	R&S	FSP 40	100047	2023/02/24	2024/02/23
Preamplifier	Agilent	8449B	3008A01954	2023/03/08	2024/03/07
Preamplifier	EMC INSTRUMENTS	EMC184045	980065	2023/10/13	2024/10/12
Preamplifier	EM Electronics corp.	EM330	60659	2023/03/10	2024/03/09
Cable-6m (9kHz~300MHz)	NA	EMC5D-BM-BM-6	130606	2023/03/13	2024/03/12
Cable-3in1 (30MHz-1GHz)	HARBOUR INDUSTRIES	LL142	CCE1315	2023/02/25	2024/02/24
Cable-0.5m (1GHz-40GHz)	HUBER SUHNER	SUCOFLEX 104	805443/4	2023/03/07	2024/03/06
Cable-3m (1GHz-40GHz)	HUBER SUHNER	SUCOFLEX 104	805796/4	2023/03/07	2024/03/06
Cable-8m (1GHz-26.5GHz)	WOKEN	WCBA-WCA203SM	CCE1374	2023/03/07	2024/03/06
Cable-1m (1GHz-40GHz)	HUBER SUHNER	HUBER SUHNER / SF102	552450	2023/06/08	2024/06/07
Cable-3m (1GHz-40GHz)	HUBER SUHNER	HUBER SUHNER / SF102	552451	2023/06/08	2024/06/07
E3	AUDIX	v8.2014-8-6	RK-000529	NA	NA
High Pass Filter	Warison	WFIL-H3000-18000F-03	WRJ5CFWC2J1	2023/07/03	2024/07/02
Notch Filter	Warison	WFIL-N5925-7125F-04	WRQ4BFWC4M1	2023/03/13	2024/03/12
Hipass Filter	Warison	WFIL-H7500-18000F	WRQ4BFWC2J1	2023/03/13	2024/03/12



Test Item	Frequency Stability				
Test Site	RFCON01-NK				
Instrument	Manufacturer	Model No	Serial No	Calibration Date	Valid Date
EXA Signal Analyzer	KEYSIGHT	N9010A	MY54200207	2023/03/14	2024/03/13
TEMP & HUMI CHAMBER	T-MACHINE	TMJ-9712	T-12-040111	2023/08/07	2024/08/06
Attenuator	KEYSIGHT	8491B	MY39250703	2023/03/08	2024/03/07
Power Meter	Anritsu	ML2495A	1224005	2023/03/07	2024/03/06
Power Sensor	Anritsu	MA2411B	1207295	2023/03/03	2024/03/02

Test Item	AC Power Line Conducted Emission				
Test Site	CON02-NK				
Instrument	Manufacturer	Model No	Serial No	Calibration Date	Valid Date
EMI Receiver	R&S	ESR 7	101906	2023/05/08	2024/05/07
TWO-LINE V-NETWORK	R&S	ENV216	102185	2023/08/29	2024/08/28
Cable-4m (9kHz-3GHz)	EMEC	RG-223	18274M	2023/07/31	2024/07/30
E3	AUDIX	v8.2014-8-6	RK-000531	NA	NA



4. Antenna Requirements

4.1. Standard Applicable

For intentional device, according to FCC 47 CFR Section 15.203, an intentional radiator shall be designed to ensure that no antenna other than that furnished by the responsible party shall be used with the device.

And according to FCC 47 CFR Section 15.249, if transmitting antennas of directional gain greater than 6dBi are used, the power shall be reduced by the amount in dB that the directional gain of the antenna exceeds 6dBi.

4.2. Antenna Construction and Directional Gain

Antenna Type	Loop Antenna
Antenna Gain	0 dBi



5. Test of AC Power Line Conducted Emission

5.1. Test Limit

Conducted Emissions were measured from 150 kHz to 30 MHz with a bandwidth of 9 KHz, according to the methods defined in ANSI C63.10-2013. The EUT was placed on a nonmetallic stand in a shielded room 0.8 meters above the ground plane. The interface cables and equipment positioning were varied within limits of reasonable applications to determine the position produced maximum conducted emissions.

Frequency (MHz)	Quasi Peak (dB μ V)	Average (dB μ V)
0.15 – 0.5	66-56*	56-46*
0.5 – 5.0	56	46
5.0 – 30.0	60	50

*Decreases with the logarithm of the frequency.

5.2. Test Procedures

- a. The EUT was placed 0.4 meter from the conducting wall of the shielding room was kept at least 80 centimeters from any other grounded conducting surface.
- b. Connect EUT to the power mains through a line impedance stabilization network (LISN).
- c. All the support units are connecting to the other LISN.
- d. The LISN provides 50 ohm coupling impedance for the measuring instrument.
- e. The FCC states that a 50 ohm, 50 micro-Henry LISN should be used.
- f. Both sides of AC line were checked for maximum conducted interference.
- g. The frequency range from 150 kHz to 30 MHz was searched.
- h. Set the test-receiver system to Peak Detect Function and Specified Bandwidth with Maximum Hold Mode.



5.3. Typical Test Setup

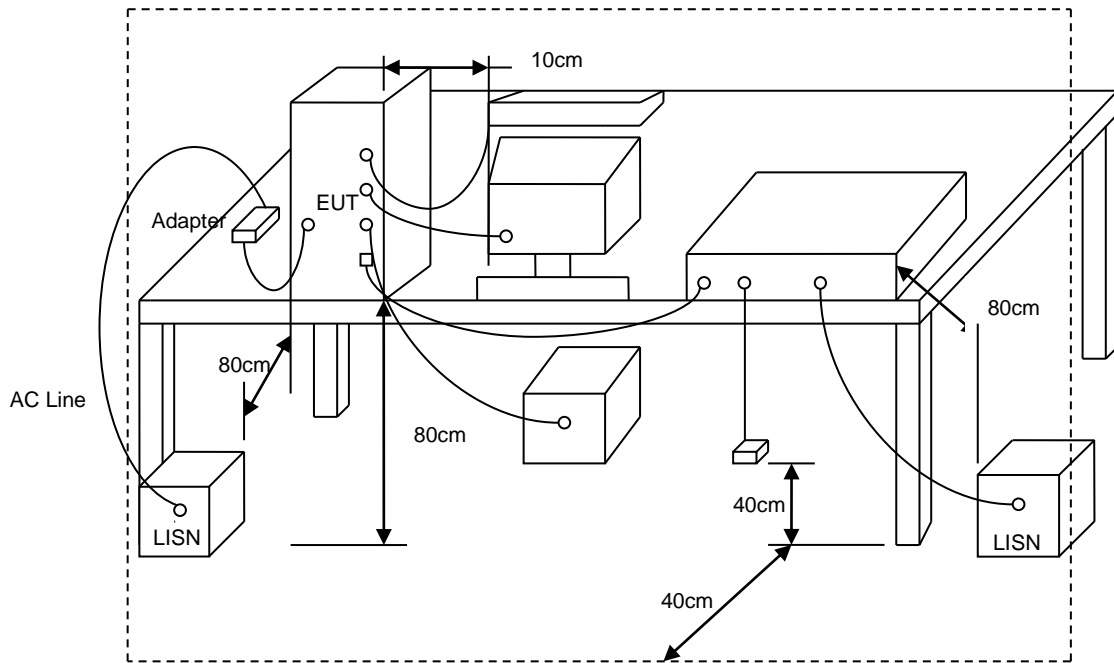



5.4. Test Result and Data

Test Mode : NFC 1TX 13.56MHz
Voltage : From POE(POE AC 120V/60Hz)
Phase : Line

Data: 17

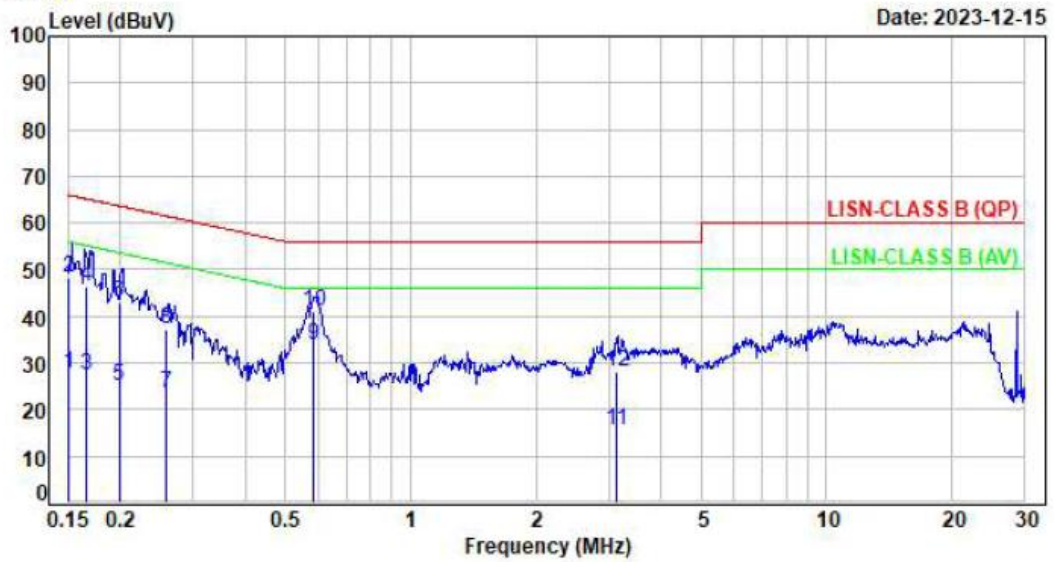

No.	Frequency (MHz)	Factor (dB)	Reading (dBuV)	Level (dBuV)	Limit (dBuV)	Margin (dB)	Detector	P/F
1	0.15	9.66	18.25	27.91	55.99	-28.08	Average	P
2	0.15	9.66	38.73	48.39	65.99	-17.60	QP	P
3	0.17	9.65	17.80	27.45	55.14	-27.69	Average	P
4	0.17	9.65	36.67	46.32	65.14	-18.82	QP	P
5	0.20	9.64	15.28	24.92	53.66	-28.74	Average	P
6	0.20	9.64	33.38	43.02	63.66	-20.64	QP	P
7	0.26	9.64	14.04	23.68	51.53	-27.85	Average	P
8	0.26	9.64	27.55	37.19	61.53	-24.34	QP	P
9	0.58	9.65	24.13	33.78	46.00	-12.22	Average	P
10	0.58	9.65	31.32	40.97	56.00	-15.03	QP	P
11	3.12	9.70	6.04	15.74	46.00	-30.26	Average	P
12	3.12	9.70	18.61	28.31	56.00	-27.69	QP	P

Note: Level=Reading+Factor
Margin=Level-Limit
Factor=(LISN or ISN or Current Probe)Factor + Cable Loss



Test Mode : NFC 1TX 13.56MHz
Voltage : From POE(POE AC 120V/60Hz)
Phase : Neutral

Data: 18

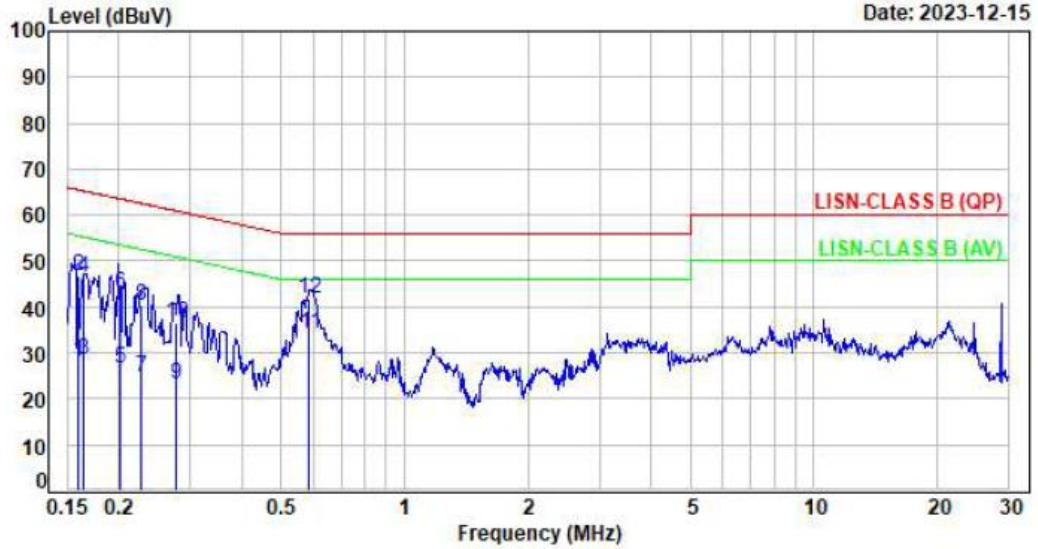

No.	Frequency (MHz)	Factor (dB)	Reading (dBuV)	Level (dBuV)	Limit (dBuV)	Margin (dB)	Detector	P/F
1	0.16	9.57	18.50	28.07	55.49	-27.42	Average	P
2	0.16	9.57	37.01	46.58	65.49	-18.91	QP	P
3	0.16	9.57	18.80	28.37	55.22	-26.85	Average	P
4	0.16	9.57	37.00	46.57	65.22	-18.65	QP	P
5	0.20	9.59	16.92	26.51	53.53	-27.02	Average	P
6	0.20	9.59	33.29	42.88	63.53	-20.65	QP	P
7	0.23	9.58	15.29	24.87	52.52	-27.65	Average	P
8	0.23	9.58	30.74	40.32	62.52	-22.20	QP	P
9	0.28	9.58	13.79	23.37	50.96	-27.59	Average	P
10	0.28	9.58	27.06	36.64	60.96	-24.32	QP	P
11	0.58	9.58	24.64	34.22	46.00	-11.78	Average	P
12	0.58	9.58	32.16	41.74	56.00	-14.26	QP	P

Note: Level=Reading+Factor
Margin=Level-Limit
Factor=(LISN or ISN or Current Probe)Factor + Cable Loss



6. Test of Radiated Emission

6.1. Test Limit

- (a) The field strength of any emissions within the band 13.553-13.567 MHz shall not exceed 15,848 microvolts/meter at 30 meters.
- (b) Within the bands 13.410-13.553 MHz and 13.567-13.710 MHz, the field strength of any emissions shall not exceed 334 microvolts/meter at 30 meters.
- (c) Within the bands 13.110-13.410 MHz and 13.710-14.010 MHz the field strength of any emissions shall not exceed 106 microvolts/meter at 30 meters.
- (d) The field strength of any emissions appearing outside of the 13.110-14.010 MHz band shall not exceed the general radiated emission limits in §15.209.

Frequency (MHz)	Distance	Limit (µV/ m)
0.09 ~ 0.490	300m	2400/F(kHz)
0.490 ~ 1.705	30m	24000/ F(kHz)
1.705 ~ 30	30m	30
30 ~ 88	3m	100
88 ~ 216	3m	150
216 ~ 960	3m	200
Above 960	3m	500

15.215 Additional provisions to the general radiated emission limitations.:

- (c) Intentional radiators operating under the alternative provisions to the general emission limits, as contained in §§15.217 through 15.257 and in subpart E of this part, must be designed to ensure that the 20 dB bandwidth of the emission, or whatever bandwidth may otherwise be specified in the specific rule section under which the equipment operates, is contained within the frequency band designated in the rule section under which the equipment is operated.



6.2. Test Procedures

- a. The EUT was placed on a rotatable table top 0.8 meter above ground.
- b. The EUT was set 3 meters from the interference receiving antenna which was mounted on the top of a variable height antenna tower.
- c. The table was rotated 360 degrees to determine the position of the highest radiation.
- d. The antenna is a broadband antenna and its height is varied between one meter and four meters above ground to find the maximum value of the field strength both horizontal polarization and vertical polarization of the antenna are set to make the measurement.
- e. For each suspected emission the EUT was arranged to its worst case and then tune the antenna tower (from 1 M to 4 M) and turn table (from 0 degree to 360 degrees) to find the maximum reading.
- f. Set the test-receiver system to Peak or CISPR quasi-peak Detect Function and specified bandwidth with Maximum Hold Mode.
- g. If the emission level of the EUT in peak mode was 3 dB lower than the limit specified, then testing will be stopped and peak values of EUT will be reported, otherwise, the emissions which do not have 3 dB margin will be repeated one by one using the quasi-peak method and reported.
- h. "Cone of radiation" has been considered to be 3dB beamwidth of the measurement antenna.

Note:

- 1. The resolution bandwidth of test receiver/spectrum analyzer is 300Hz or CISPS 200Hz(QP detector) at frequency Below 150 kHz.
- 2. The resolution bandwidth of test receiver/spectrum analyzer is 10KHz or CISPS 9KHz(QP detector) at frequency 150 kHz to 30 MHz.
- 3. The resolution bandwidth and video bandwidth of test receiver/spectrum analyzer is 120kHz for Peak detection (PK) and Quasi-peak detection (QP) at frequency below 1GHz.

Note: The supporting fixture shall permit orientation of the EUT in each of three orthogonal axis positions such that emissions from the EUT are maximized. (X-AXIS is the worst.)



6.3. Typical Test Setup Layout of Radiated Emission

Below 30MHz test setup

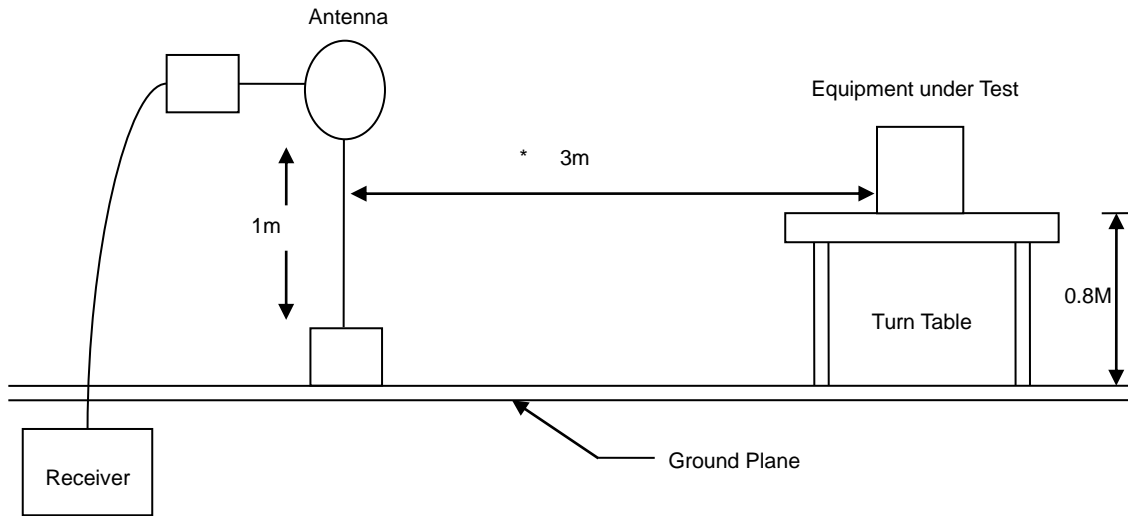

30MHz- 1GHz Test Setup

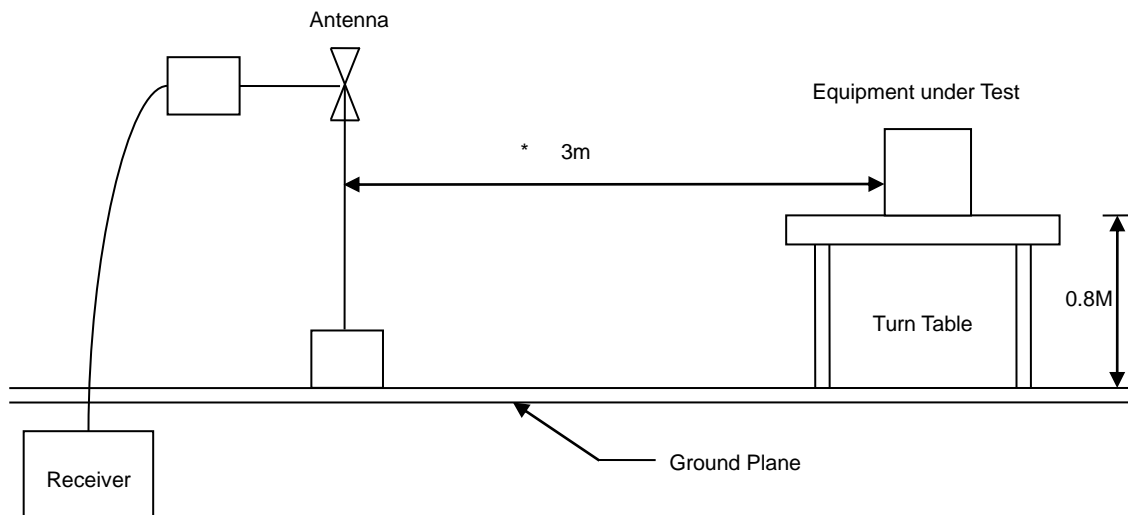



6.4. Test Result and Data

6.4.1. Test Result of Fundamental Emission

Test Mode : NFC 1TX 13.56MHz
 Voltage : From POE(AC120V/60Hz)
 Remark : Adapter:GP-V480-032G

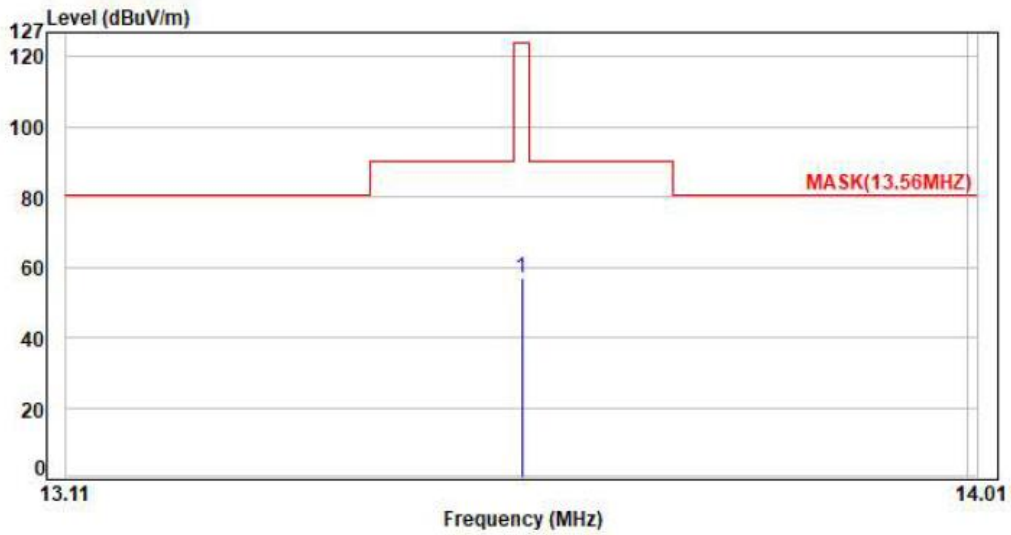

No.	Frequency (MHz)	Factor (dB)	Reading (dBuV)	Level (dBuV/m)	Limit (dBuV/m)	Margin (dB)	Detector	Height (cm)	Azimuth (deg)	P/F
1	13.56	21.75	34.99	56.74	124.00	-67.26	Peak	100	360	P

Note: Level=Reading+Factor
 Margin=Level-Limit
 Factor=Antenna Factor + cable loss - Amplifier Factor



Test Mode : NFC 1TX 13.56MHz
Voltage : From POE(AC120V/60Hz)
Remark : Adapter:GP-V480-032G

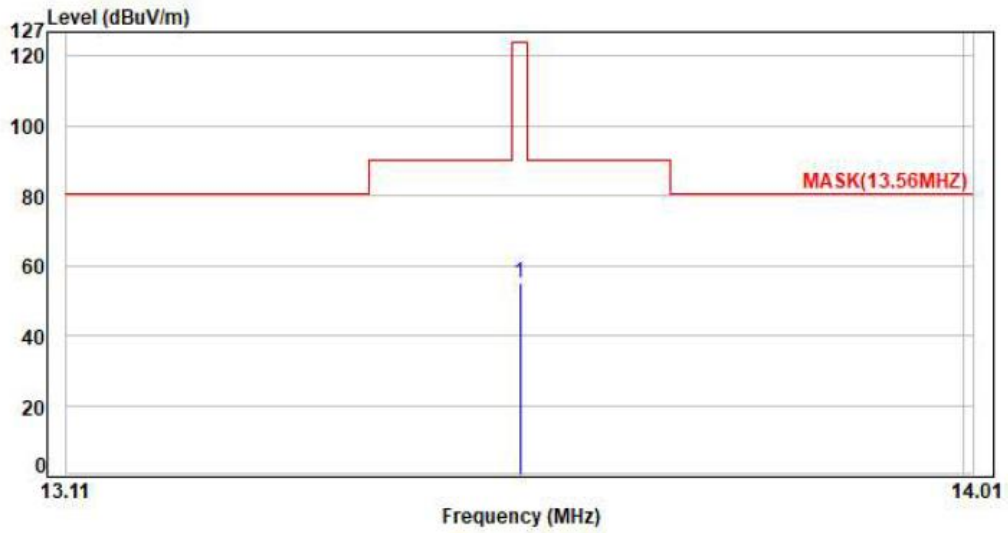

No.	Frequency (MHz)	Factor (dB)	Reading (dBuV)	Level (dBuV/m)	Limit (dBuV/m)	Margin (dB)	Detector	Height (cm)	Azimuth (deg)	P/F
1	13.56	21.75	33.25	55.00	124.00	-69.00	Peak	100	360	P

Note: Level=Reading+Factor
Margin=Level-Limit
Factor=Antenna Factor + cable loss - Amplifier Factor



6.4.2. Test Result of Unwanted Spurious emission (9KHz ~ 30MHz)

Test Mode : NFC 1TX 13.56MHz
Voltage : From POE(AC120V/60Hz)
Remark : LOOP OPEN

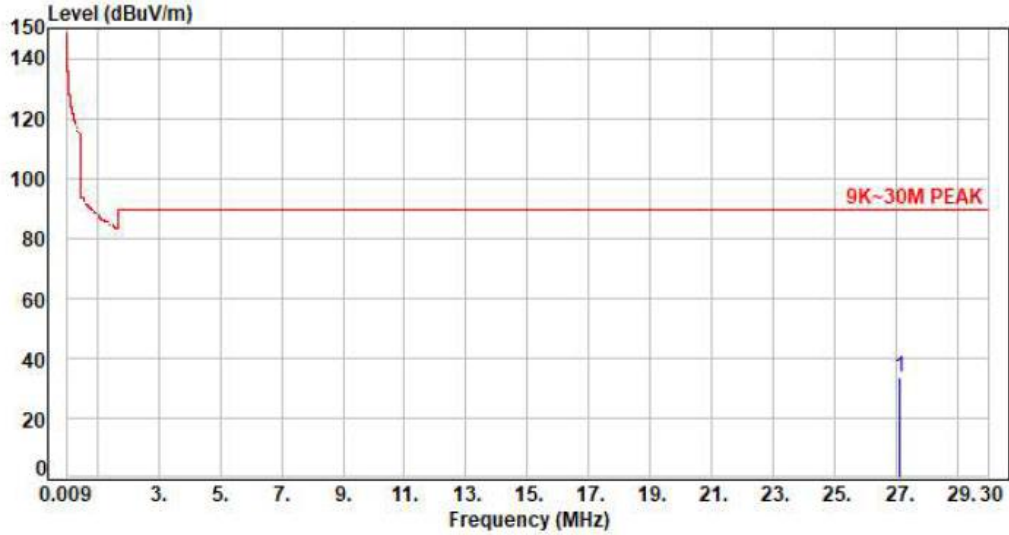
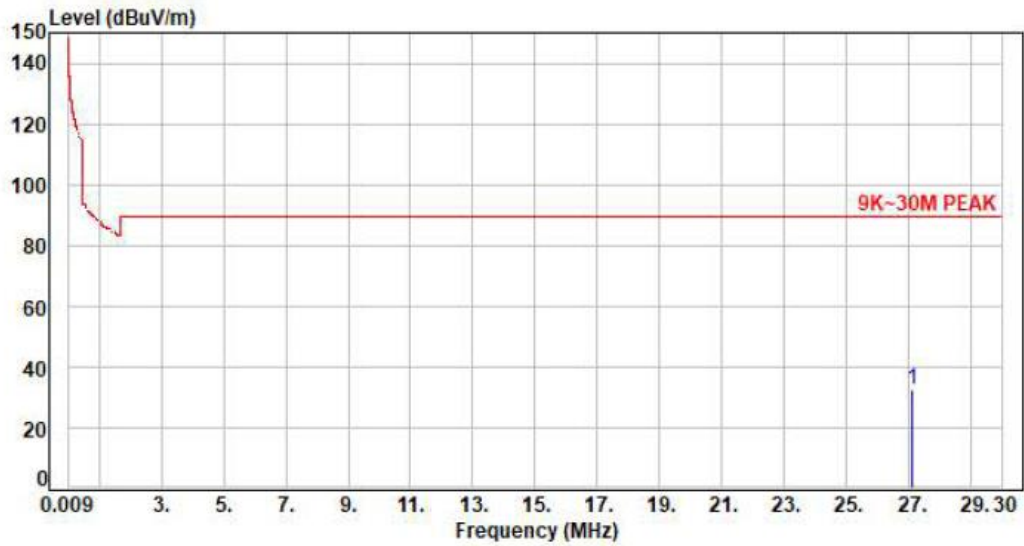

Table with 10 columns: No., Frequency (MHz), Factor (dB), Reading (dBuV), Level (dBuV/m), Limit (dBuV/m), Margin (dB), Detector, Height (cm), Azimuth (deg), P/F. Row 1: 1, 27.12, 22.02, 11.70, 33.72, 89.54, -55.82, Peak, 150, 360, P

Note: Level=Reading+Factor
Margin=Level-Limit
Factor=Antenna Factor + cable loss - Amplifier Factor



Test Mode : NFC 1TX 13.56MHz
Voltage : From POE(AC120V/60Hz)
Remark : LOOP CLOSE



No.	Frequency (MHz)	Factor (dB)	Reading (dBuV)	Level (dBuV/m)	Limit (dBuV/m)	Margin (dB)	Detector	Height (cm)	Azimuth (deg)	P/F
1	27.12	22.02	10.59	32.61	89.54	-56.93	Peak	150	360	P

Note: Level=Reading+Factor
Margin=Level-Limit
Factor=Antenna Factor + cable loss - Amplifier Factor



6.4.3. Test Result of Unwanted Spurious emission (30GHz ~ 1GHz)

Test Mode : NFC 1TX 13.56MHz
Voltage : From POE(AC240V/60Hz)
Pol : Vertical

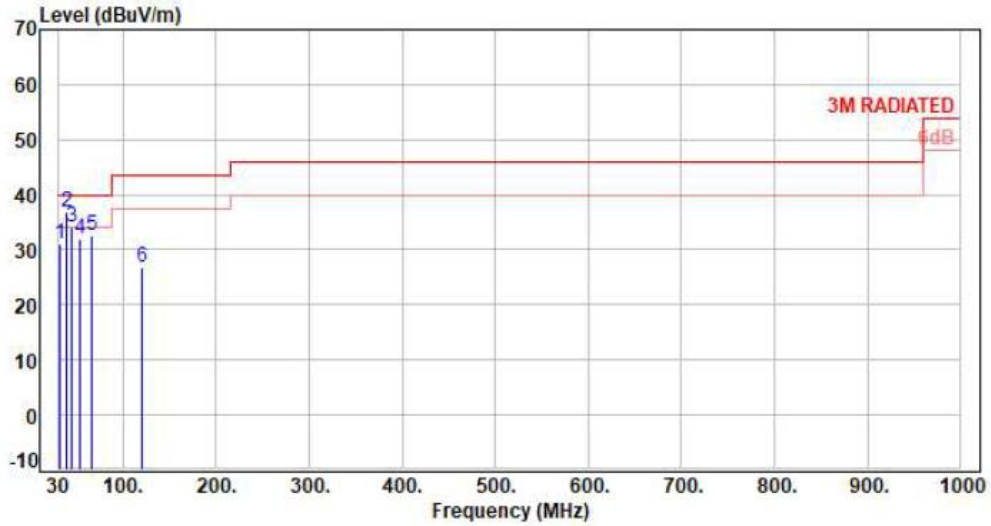

Table with 10 columns: No., Frequency (MHz), Factor (dB), Reading (dBuV), Level (dBuV/m), Limit (dBuV/m), Margin (dB), Detector, Height (cm), Azimuth P/F (deg). It contains 6 rows of data corresponding to the spikes in the graph.

Note: Level=Reading+Factor
Margin=Level-Limit
Factor=Antenna Factor + cable loss - Amplifier Factor



Test Mode : NFC 1TX 13.56MHz
Voltage : From POE(AC240V/60Hz)
Pol : Horizontal

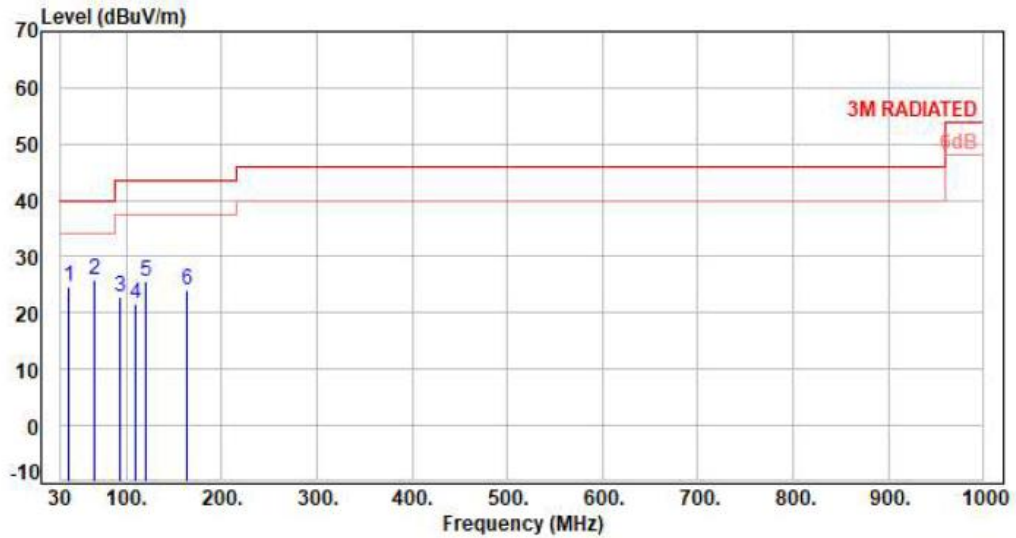

Table with 11 columns: No., Frequency (MHz), Factor (dB), Reading (dBuV), Level (dBuV/m), Limit (dBuV/m), Margin (dB), Detector, Height (cm), Azimuth (deg), P/F. It lists six data points corresponding to peaks 1-6.

Note: Level=Reading+Factor
Margin=Level-Limit
Factor=Antenna Factor + cable loss - Amplifier Factor



6.5. 20dB Bandwidth

Modulation Mode	Freq. (MHz)	20dB Bandwidth (kHz)	F _L at 20dB BW (MHz)	F _H at 20dB BW (MHz)
RFID	13.56	2.8	13.5589	13.5617
Limit		N/A	13.553	13.567
Result	Pass			

20dB Bandwidth
13.56 MHz

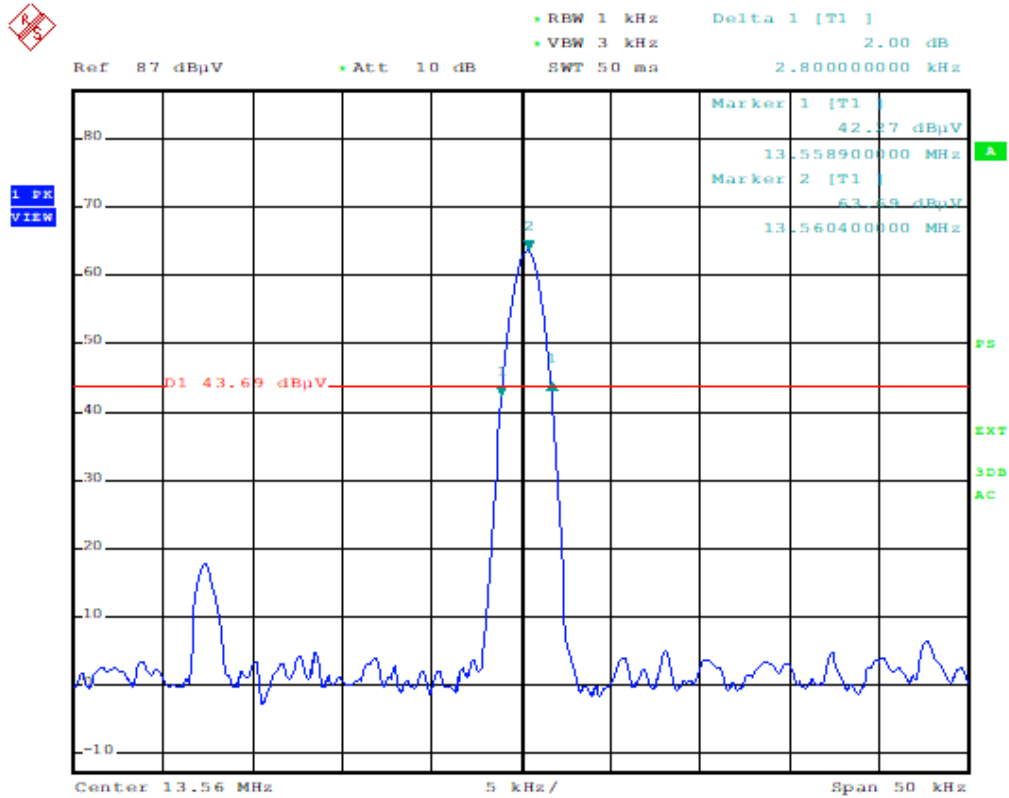



7. Frequency Stability

7.1. Test Procedure

According to the methods defined in ANSI C63.10-2013 Section 6.8

1. The EUT was placed inside the Temperature and Humidity chamber.
2. The transmitter output was connected to spectrum analyzer.
3. Turn the EUT on and couple its output to a spectrum analyzer.
4. Turn the EUT off and set the chamber to the highest temperature specified.
5. Allow sufficient time (approximately 30 min) for the temperature of the chamber to stabilize, turn the EUT on and measure the operating frequency after 2, 5, and 10 minutes.
6. Repeat step 2 and 3 with the temperature chamber set to the lowest temperature.
7. The test chamber was allowed to stabilize at +20 degree C for a minimum of 30 minutes. The supply voltage was then adjusted on the EUT from 85% to 115% and the frequency record.

7.2. Test Setup Layout

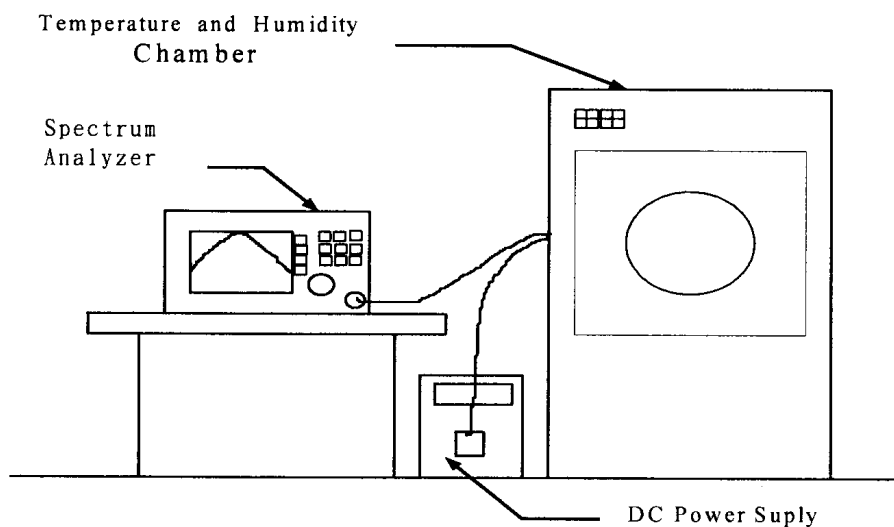



7.3. Test Result and Data

Operating frequency: 13.56MHz

NFC-A ISO14443A									
Temp (°C)	Power supply (V)	0 minute		2 minute		5 minute		10 minute	
		(MHz)	(%)	(MHz)	(%)	(MHz)	(%)	(MHz)	(%)
50	102	13.5599	-0.000590	13.5599	-0.000442	13.5600	-0.000295	13.5600	-0.000295
	120	13.5599	-0.000590	13.5599	-0.000442	13.5600	-0.000295	13.5600	-0.000295
	138	13.5599	-0.000590	13.5599	-0.000442	13.5600	-0.000295	13.5600	-0.000295
40	102	13.5599	-0.000590	13.5599	-0.000590	13.5599	-0.000590	13.5599	-0.000590
	120	13.5599	-0.000590	13.5599	-0.000590	13.5599	-0.000590	13.5599	-0.000590
	138	13.5592	-0.005900	13.5599	-0.000590	13.5599	-0.000590	13.5599	-0.000590
30	102	13.5599	-0.000590	13.5599	-0.000737	13.5599	-0.000737	13.5599	-0.000737
	120	13.5599	-0.000737	13.5599	-0.000737	13.5599	-0.000737	13.5599	-0.000737
	138	13.5599	-0.000590	13.5599	-0.000590	13.5599	-0.000737	13.5599	-0.000737
20	102	13.5599	-0.000590	13.5599	-0.000737	13.5599	-0.000737	13.5599	-0.000737
	120	13.5599	-0.000590	13.5599	-0.000737	13.5599	-0.000737	13.5599	-0.000737
	138	13.5599	-0.000590	13.5599	-0.000737	13.5599	-0.000737	13.5599	-0.000737
10	102	13.5599	-0.000590	13.5599	-0.000590	13.5599	-0.000590	13.5599	-0.000442
	120	13.5599	-0.000590	13.5599	-0.000590	13.5599	-0.000442	13.5599	-0.000442
	138	13.5599	-0.000590	13.5599	-0.000590	13.5599	-0.000442	13.5599	-0.000442
0	102	13.5600	-0.000295	13.5600	-0.000295	13.5600	-0.000295	13.5600	-0.000295
	120	13.5600	-0.000295	13.5600	-0.000295	13.5600	-0.000295	13.5600	-0.000295
	138	13.5600	-0.000295	13.5600	-0.000295	13.5600	-0.000295	13.5600	-0.000295
-10	102	13.5600	-0.000147	13.5600	-0.000147	13.5600	-0.000147	13.5600	-0.000147
	120	13.5600	-0.000147	13.5600	0.000000	13.5600	0.000000	13.5600	-0.000147
	138	13.5600	-0.000147	13.5600	0.000000	13.5600	-0.000147	13.5600	-0.000147
-20	102	13.5600	0.000147	13.5600	0.000147	13.5600	0.000147	13.5600	0.000147
	120	13.5600	0.000147	13.5600	0.000147	13.5600	0.000147	13.5600	0.000147
	138	13.5600	0.000147	13.5600	0.000147	13.5600	0.000147	13.5600	0.000147
-30	102	13.5600	0.000147	13.5600	0.000147	13.5600	0.000295	13.5600	0.000147
	120	13.5600	0.000000	13.5600	0.000295	13.5600	0.000147	13.5600	0.000147
	138	13.5600	0.000147	13.5600	0.000147	13.5600	0.000295	13.5600	0.000147