



427 West 12800 South  
 Draper, UT 84020

## Test Report Certification

<b>FCC ID</b>	SWX-U7PROP
<b>Canada ID</b>	6545A-U7PROP
<b>Equipment Under Test</b>	U7 Pro
<b>Test Report Serial Number</b>	TR9343_05
<b>Date of Test(s)</b>	19, 23, 29 and 30 August 2024
<b>Report Issue Date</b>	3 September 2024

Test Specification	Applicant
47 CFR FCC Part 15, Subpart E RSS-GEN	Ubiquiti Inc. 685 Third Avenue New York, NY 10019 U.S.A.



NVLAP LAB CODE 600241-0

---

## Certification of Engineering Report

This report has been prepared by Unified Compliance Laboratory (UCL) to document compliance of the device described below with the requirement of Federal Communication Commissions (FCC) Part 15, Subpart E. This report may be reproduced in full. Partial reproduction of this report may only be made with the written consent of the laboratory. The results in this report apply only to the sample tested.

<b>Applicant</b>	Ubiquiti Inc.
<b>Manufacturer</b>	Ubiquiti Inc.
<b>Brand Name</b>	UBIQUITI
<b>Model Number</b>	U7 Pro
<b>FCC ID</b>	SWX-U7PROP
<b>Canada ID</b>	6545A-U7PROP

On this 3<sup>rd</sup> day of September 2024, I individually and for Unified Compliance Laboratory certify that the statements made in this engineering report are true, complete, and correct to the best of my knowledge and are made in good faith.

Although NVLAP has accredited the Unified Compliance Laboratory testing facilities, this report must not be used to claim product certification, approval, or endorsement by NVLAP, NIST or any agency of the U.S. federal government.

Unified Compliance Laboratory

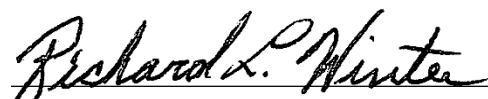
  
\_\_\_\_\_  
Written By: Joseph W. Jackson  
\_\_\_\_\_  
Reviewed By: Richard L. Winter

---

<b>Revision History</b>		
<b>Revision</b>	<b>Description</b>	<b>Date</b>
01	Original Report Release	3 September 2024
02	Added DFS Spot Check Data In Section 2	12 September 2024
03	Revised Sections 2.2 and 2.3. Added Sections 2.4 and 2.5	16 September 2024
04	Removed Section 2.5	16 September 2024
05	Revised Section 2.4 and add Section 2.5	25 September 2024

## Table of Contents

1	Client Information.....	5
1.1	Applicant.....	5
1.2	Manufacturer.....	5
2	Summary .....	6
2.1	Identification of EUT .....	6
2.2	Introduction.....	6
2.3	Description of EUT Differences and Justification .....	7
2.4	U7 Pro Spot Check Test Plan.....	8
2.5	Illustrations .....	9
3	Spot Check Test Data.....	10
3.1	Power and PSD .....	10
3.2	DFS .....	12
3.3	U7 Pro Spot Check – Radiated TX Spurious Emissions.....	17

# 1 Client Information

## 1.1 Applicant

<b>Company</b>	Ubiquiti Inc. 685 Third Avenue New York, NY 10017 U.S.A.
<b>Contact Name</b>	Alex Macon
<b>Title</b>	Compliance Manager

## 1.2 Manufacturer

<b>Company</b>	Ubiquiti Inc. 685 Third Avenue New York, NY 10017 U.S.A.
<b>Contact Name</b>	Alex Macon
<b>Title</b>	Compliance Manager

## 2 Summary

### 2.1 Identification of EUT

<b>Brand Name</b>	UBIQUITI
<b>Model Number</b>	U7 Pro
<b>Serial Number</b>	05B1B5
<b>Dimensions (cm)</b>	20.6 x 20.6 x 4.6

### 2.2 Introduction

The purpose of this document is to provide definition of the differences between models and evidence of their similarities. It will also identify the test data that is to be used between the models and identifies the data that will be new to the U7 Pro. This document is based on guidance provided in KDB 484596 DO1 Referencing Test Data. The applicant takes full responsibility for the fact that the test data referenced in this test report represents valid data for demonstrating compliance for the variants listed in this application. The following tables outline the identifying devices.

#### 2.2.1 U7-Pro – (Original Equipment) Certification

	<b>Equipment Class</b>	<b>Rule Part</b>	<b>Frequency Bands</b>
U7-Pro	DTS	Part 15 C	2412 – 2462 MHz
	NII	Part 15 E	5180 – 5240 MHz
	NII	Part 15 E	5260 – 5320 MHz
	NII	Part 15 E	5500 – 5720 MHz
	NII	Part 15 E	5745 – 5825 MHz
	NII (6ID)	Part 15 E	5955 – 7115 MHz
	NII (6PP)	Part 15 E	5955 – 7115 MHz

#### 2.2.2 U7 Pro – (New Original Equipment) Certification

	<b>Equipment Class</b>	<b>Rule Part</b>	<b>Frequency Bands</b>
U7 Pro	DTS	Part 15 C	2412 – 2462 MHz
	NII	Part 15 E	5180 – 5240 MHz
	NII	Part 15 E	5260 – 5320 MHz
	NII	Part 15 E	5500 – 5720 MHz
	NII	Part 15 E	5745 – 5825 MHz
	NII (6ID)	Part 15 E	5955 – 7115 MHz
	NII (6PP)	Part 15 E	5955 – 7115 MHz

---

## 2.3 Description of EUT Differences and Justification

U7-Pro (FCC ID: SWX-U7PRO / IC ID: 6545A-U7PRO) is identical to the U7 Pro (FCC ID: SWX-U7PROP / 6545A-U7PROP) in hardware and software other than the RF circuitry for the 2412 – 2462 MHz WiFi Band. In the 2412 – 2462 MHz WiFi Band the RF circuitry was changed from a one System on Chip (SOC) to a two chip set.

This change only affects the FCC Part 15 C of the FCC rules in the Equipment Class DTS. This band of the U7 Pro was completely retested and the testing results are found in test report “U7\_Pro\_FCC\_15.247\_WiFi\_01”

No changes have been made in the hardware or software for the UNII-1 Band (5180–5240 MHz), UNII-2a Band (5260–5320 MHz), UNII-2c Band (5500–5720 MHz), (UNII-3 Band (5745–5825 MHz), UNII-5 Band (5955–6415 MHz), UNII-6 Band (6435–6515 MHz), UNII-7 Band (6535–6875 MHz) and UNII-8 Band (6895–7115 MHz). Since no changes have been made in these bands the applicant declares that the test date referenced in this test report represents valid data for demonstrating compliance for the variants listed in this application.

This spot check test report along with the original test report for the NII bands listed above are provided to show that since no changes have been made to the equipment subject to FCC Part 15 E of the FCC rules, the U7 Pro continues to comply with the FCC Rules and Regulations.

### 2.3.1 U7-Pro (Original Equipment) Certification

The U7-Pro was originally granted on 12/08/2023 for the frequency bands of 2412–2462 MHz, per CFR Part 15C, 15.247; 5180–5240 MHz, 5260–5320 MHz, 5500–5720 MHz, 5745–5825 MHz, per CFR Part 47 Part 15E, 15.407 and originally granted on 01/04/2024 for the frequency bands of 5955–7115 MHz, per CFR Part 47 Part 15E.

### 2.3.2 U7 Pro (New Equipment Certification) Proposal

The U7 Pro is requesting a grant for the frequency bands of 2412–2462 MHz, per CFR Part 15C, 15.247; 5180–5240 MHz; 5260–5320 MHz; 5500–5720 MHz; 5745–5825 MHz; and 5955–7115 MHz, per CFR Part 47 Part 15E.

The frequency bands of 5180–5240 MHz; 5260–5320 MHz; 5500–5720 MHz; 5745–5825 MHz; and 5955 – 7115 MHz have no hardware or software changes from the original certification of the U7-Pro (SWX-U7PRO / 6545A-U7PRO).

The frequency band of 2412–2462 MHz will be covered by a new separate test report due to the changes in this frequency band as described in Section 2.3 above and is the reason for this application.

## 2.4 U7 Pro Spot Check Test Plan

The spot-check plan listed in this section was formulated using good engineering judgement based on the knowledge of the device design by the Ubiquiti Inc. engineering team. The grantee of this device takes full responsible for the continued compliance to the FCC Rules. With this good engineering judgement, the confidence is high that the variant device will continue to be compliance with all the relevant FCC Rule parts.

### 2.4.1 Cross Reference Table

Reference Device	Variant Device	Key Differences
Model U7-Pro FCC ID: SWX-U7PRO	Model U7 Pro FCC ID: SWX-U7PROP	2412 – 2462 MHz WiFi Band the RF circuitry was changed from a one System on Chip (SOC) to a two chip set  See Section 2.3 above

Rule Part	Test Item	Data Referencing	Comments
15.247	All testing	No	The 15.247 testing was completely retested. See test report U7_Pro_FCC_15.247_WiFi_01
U-NII Bands			
15.407	AC Mains Conducted	No	Note 1 Note 2
15.407	Bandwidth Requirement	No	Note 1 Note 2
15.407	Output Power	Yes	See Section 3.1
15.407	Spurious Emissions	Yes	See Section 3.3
15.407	Power Spectral Density	Yes	See Section 3.1
15.407 (U-NII-2)	DFS Requirement	Yes	See Section 3.2

Note 1: The following are the original test report references for UNII-1, UNII-2, UNII-3 and UNII-5 respectfully

- TR8594\_U7-Pro\_FCC\_15.407\_UNII-1\_02
- TR8570\_U7-Pro\_15.407\_UNII-2\_02
- TR8575\_U7-Pro\_15.407\_UNII-3\_01
- TR8585\_U7-Pro\_FCC\_15.407\_UNII-5\_04

Note 2: Combined Spot Check report combined with original report are:

- TR9367\_U7\_Pro\_FCC\_15.407\_UNII-1\_04
- TR9368\_U7\_Pro\_FCC\_15.407\_UNII-2\_04



- TR9369\_U7\_Pro\_FCC\_15.407\_UNII-3\_04
- TR9370\_U7\_Pro\_FCC\_15.407\_UNII-5\_04

## **2.4.2 Acceptance Criteria**

The accepted criteria is listed under sections 2.4.3, 2.4.4 and 2.4.5.

### **2.4.3 U7 Pro Spot Check – Power / PSD**

Per KDB 484596 DO1 a spot check was conducted for the bands that have no changes applied, 5180–5240 MHz; 5260–5320 MHz; 5500–5720 MHz; 5745–5825 MHz; and 5955–7115 MHz, to ensure the levels are still less than the original power reported during the certification process. Below is the spot check comparison with test report references. The test reports noted below will also be submitted to the TCB for reference.

The accepted criteria for the outcome of the spot check is continued compliance to the FCC Rules and reasonable close results to the original test data.

### **2.4.4 U7 Pro Spot Check – DFS**

Per KDB 484596 D01 a spot check was conducted for the bands that have no changes applied, 5500-5720 MHz to ensure the level are still less than the original reported DFS during the original certification process. Below is the spot check comparison for the DFS portion.

The accepted criteria for the outcome of the spot check is continued compliance to the FCC Rules and reasonable close results to the original test data.

### **2.4.5 U7 Pro Spot Check – Radiated Emissions**

Per KDB 484596 D01 a spot check was conducted for radiated emissions in the UNII-1, UNII-2 and UNII-5 bands that have no changes applied. Below is the spot check comparison for the Radiated Emissions portion.

The accepted criteria for the outcome of the spot check is continued compliance to the FCC Rules and reasonable close results to the original test data.

## **2.5 Illustrations**

The illustration exhibit is being submitted separately due to the size restrictions. The exhibit is titled, “U7\_Pro\_Internal\_Illustrations\_Comparison.”

### 3 Spot Check Test Data

#### 3.1 Power and PSD

**5180–5240 MHz Band UNII-1 Spot Check**

Mode	Frequency	UCL Results (10/3/2023)		UCL Results (8/29/2024)		Delta	
		RF Pwer	PSD	RF Pwer	PSD	RF Pwer	PSD
		W	dbm	W	dBm	W	dBm
HE20	5180	0.177	9.25	0.137	8.57	- 0.04	- 0.68
HE20	5210	0.415	12.86	0.334	12.44	- 0.08	- 0.42
HE20	5240	0.540	13.97	0.388	13.20	- 0.15	- 0.77
HE40	5190	0.113	4.37	0.088	4.05	- 0.03	- 0.32
HE40	5230	0.234	7.20	0.173	6.88	- 0.06	- 0.32
HE80	5210	0.134	1.75	0.099	1.39	- 0.04	- 0.36

#### 5260–5320 MHz Band

**UNII-2A Spot Check**

Mode	Frequency	UCL Results (9/8/2023)		UCL Results (8/29/2024)		Delta	
		RF Pwer	PSD	RF Pwer	PSD	RF Pwer	PSD
		W	dbm	W	dBm	W	dBm
HE20	5260	0.230	10.11	0.185	9.66	- 0.05	- 0.45
HE20	5280	0.211	9.90	0.183	9.64	- 0.03	- 0.26
HE20	5320	0.208	9.72	0.195	9.85	- 0.01	0.13
HE40	5270	0.226	7.03	0.184	6.80	- 0.04	- 0.23
HE40	5310	0.220	6.82	0.199	6.98	- 0.02	0.16
HE80	5290	0.202	3.58	0.180	3.67	- 0.02	0.09
HE160	5250	0.225	1.18	0.180	0.64	- 0.05	- 0.54

**5500–5720 MHz Band**
**UNII-2C Spot Check**

Mode	Frequency	UCL Results (9/8/2023)		UCL Results (8/30/2024)		Delta	
		RF Pwer	PSD	RF Pwer	PSD	RF Pwer	PSD
		W	dbm	W	dBm	W	dBm
HE20	5500	0.242	10.55	0.217	10.70	- 0.02	0.15
HE20	5600	0.201	9.96	0.163	9.68	- 0.04	- 0.28
HE20	5720	0.250	10.75	0.173	10.15	- 0.08	- 0.60
HE40	5510	0.242	7.53	0.215	7.67	- 0.03	0.14
HE40	5590	0.207	6.90	0.164	6.60	- 0.04	- 0.30
HE40	5710	0.203	6.81	0.137	5.99	- 0.07	- 0.82
HE80	5530	0.237	4.41	0.205	6.08	- 0.03	1.67
HE80	5610	0.248	4.72	0.188	4.41	- 0.06	- 0.31
HE80	5690	0.240	4.74	0.155	3.62	- 0.09	- 1.12
HE160	5570	0.229	1.46	0.204	1.79	- 0.03	0.33

### 3.2 DFS

#### DFS Spot Check – 10 Trials at 80 MHz – All wave Forms

Original Summary Table from 10/18/2023

Summary			
Type	Detections	Trials	Detection Probability
Type 1	29	30	97%
Type 2	28	30	93%
Type 3	25	30	83%
Type 4	28	30	93%
Type 5	30	30	100%
Type 6	30	30	100%
Aggregate 1-4	110	120	92%

New Summary Table and Data from 9/11/2024

Summary			
Type	Detections	Trials	Detection Probability
Type 1	9	10	90%
Type 2	9	10	90%
Type 3	9	10	90%
Type 4	8	10	80%
Type 5	10	10	100%
Type 6	10	10	100%
Aggregate 1-4	35	40	88%

#### Trials

RADAR TYPE 1				Rohde & Schwarz K350 Pulse Sequencer DFS
Trial #	Number of Pulses per Burst	Pulse Width (µsec)	PRI (µs)	Detection (yes/no)
1	46	1	1152	y
2	58	1	918	y
3	19	1	2877	n

4	31	1	1726	y
5	18	1	2948	y
6	53	1	996	y
7	19	1	2829	y
8	87	1	611	y
9	31	1	1733	y
10	25	1	2148	y

9/10=90%

RADAR TYPE 2				Rohde & Schwarz K350 Pulse Sequencer DFS
Trial #	Number of Pulses per Burst	Pulse Width (µsec)	PRI (µs)	Detection (yes/no)
1	28	3.9	169	y
2	29	2.2	182	y
3	28	1.4	222	n
4	29	2	166	y
5	28	2.7	203	y
6	25	4	196	y
7	26	1.5	152	y
8	27	2.4	225	y
9	28	4.5	169	y
10	24	3.2	170	y

9/10=90%

RADAR TYPE 3				Rohde & Schwarz K350 Pulse Sequencer DFS
Trial #	Number of Pulses per Burst	Pulse Width (µsec)	PRI (µs)	Detection (yes/no)
1	18	9	387	y
2	17	9	433	y
3	18	6.1	453	y
4	17	6.7	368	n
5	17	9.5	241	y
6	16	6.5	337	y
7	17	9.2	288	y
8	18	8.1	474	y
9	16	6.2	284	y
10	18	9.6	476	y

9/10=90%

RADAR TYPE 4				Rohde & Schwarz K350 Pulse Sequencer DFS
Trial #	Number of Pulses per Burst	Pulse Width (µsec)	PRI (µs)	Detection (yes/no)
1	12	14.8	237	y
2	15	17	437	n
3	13	19.9	352	y
4	15	14	389	y
5	12	16	304	y
6	15	12.7	350	y
7	12	12.2	204	y
8	16	12.9	367	y
9	12	18.6	422	n
10	13	18	484	y

8/10=80%

TYPE 5		Rohde & Schwarz K350 Pulse Sequencer DFS		
Trial #	Detection (yes/no)	Chirp Width (MHz)	Subset	Fc
1	y	11	1	5570
2	y	19	1	5570
3	y	17	1	5570
4	y	13	1	5570
5	y	12	1	5570
6	y	17	1	5570
7	y	18	1	5570
8	y	9	1	5570
9	y	6	1	5570
10	y	13	1	5570

10/10=100%

TYPE 6 S		Rohde & Schwarz K350 Pulse Sequencer DFS
Trial #	Detection (yes/no)	
1	y	
2	y	
3	y	
4	y	
5	y	
6	y	
7	y	
8	y	
9	y	
10	y	

10/10=100%

**5745–5825 MHz Band**
**UNII-3 Spot Check**

Mode	Frequency	UCL Results (10/4/2023)		UCL Results (8/30/2024)		Delta	
		RF Pwer	PSD	RF Pwer	PSD	RF Pwer	PSD
		W	dbm	W	dBm	W	dBm
HE20	5745	0.697	12.12	0.465	11.29	- 0.23	- 0.83
HE20	5775	0.840	13.03	0.594	11.50	- 0.25	- 1.53
HE20	5825	0.621	11.33	0.490	10.71	- 0.13	- 0.62
HE40	5755	0.540	7.90	0.364	7.50	- 0.18	- 0.40
HE40	5775	0.628	8.70	0.401	7.19	- 0.23	- 1.51
HE40	5795	0.587	8.27	0.378	7.75	- 0.21	- 0.52
HE80	5775	0.244	1.81	0.163	1.36	- 0.08	- 0.45

**5955–7115 MHz Band**
**UNII-5 Spot Check**

Mode	Frequency	UCL Results (11/16/2023)		UCL Results (8/30/2024)		Delta	
		RF Pwer	PSD	RF Pwer	PSD	RF Pwer	PSD
		W (eirp)	dbm	W (eirp)	dBm	W (eirp)	dBm
EHT20	5955	0.062	-1.27	0.038	-1.82	- 0.02	- 0.55
EHT20	6195	0.071	-0.87	0.056	-1.22	- 0.01	- 0.35
EHT20	6415	0.074	-1.33	0.043	-2.81	- 0.03	- 1.48
EHT40	5965	0.139	-1.72	0.084	-1.72	- 0.06	0.00
EHT40	6205	0.143	-1.11	0.113	-1.33	- 0.03	- 0.22
EHT40	6405	0.153	-1.27	0.094	-2.22	- 0.06	- 0.95
EHT80	5985	0.262	-0.99	0.187	-1.39	- 0.08	- 0.40
EHT80	6225	0.277	-1.16	0.223	-1.19	- 0.05	- 0.03
EHT80	6385	0.282	-1.49	0.187	-2.31	- 0.09	- 0.82
EHT160	6025	0.467	-1.24	0.300	-1.59	- 0.17	- 0.35
EHT160	6185	0.492	-1.02	0.445	-0.95	- 0.05	0.07
EHT160	6325	0.578	-1.37	0.438	-1.37	- 0.14	0.00
EHT320	6265	0.869	-1.56	0.676	-2.13	- 0.19	- 0.57



### 3.3 U7 Pro Spot Check – Radiated TX Spurious Emissions

Per KDB 484596 DO1 a spot was conducted for the bands that have no changes applied (5180–5240 MHz; 5260–5320 MHz; 5500–5720 MHz; 5745–5825 MHz; and 5955–7115 MHz) to ensure the levels of spurious / harmonic emissions comply with CFR 47 Part 15.209 and 15.255 respectively as reported during the certification process. Below is the spot check comparison with test report references. The test report noted below will also be submitted to the TCB for reference.

#### UNII-1 Spurious Low Channel 1 – 17 GHz

Previous Data as recorded in Report #: U7-Pro\_FCC\_15.407\_UNII-1\_02

Peak

Frequency	Level (dB $\mu$ V/m)	Limit (dB $\mu$ V/m)	Margin (dB)	Azimuth (°)	Height (m)	Pol.	Correction (dB)
10.37 GHz	55.017	74	-18.98	136	1.643	Vertical	8.55
11.91 GHz	58.708	74	-15.29	87	1.638	Vertical	10.05
15.54 GHz	66.609	74	-7.39	124	2.645	Vertical	10.59
10.35 GHz	55.596	74	-18.40	162	2.645	Horizontal	8.39
15.53 GHz	59.965	74	-14.04	148	3.154	Horizontal	10.60

Avg

Frequency	Level (dB $\mu$ V/m)	Limit (dB $\mu$ V/m)	Margin (dB)	Azimuth (°)	Height (m)	Pol.	Correction (dB)
10.37 GHz	41.564	54	-12.44	136	1.643	Vertical	8.55
11.91 GHz	52.136	54	-1.86	87	1.638	Vertical	10.05
15.54 GHz	52.195	54	-1.81	124	2.645	Vertical	10.59
10.35 GHz	42.29	54	-11.71	162	2.645	Horizontal	8.39
15.53 GHz	45.337	54	-8.63	148	3.154	Horizontal	10.60

#### UNII-1 Spurious Low Channel

Data taken 8/19/2024

Peak

Frequency	Level (dB $\mu$ V/m)	Limit (dB $\mu$ V/m)	Margin (dB)	Azimuth (°)	Height (m)	Pol.	Correction (dB)
12.40 GHz	54.732	74	-19.27	89	2.329	Vertical	13.99
14.82 GHz	56.135	74	-17.87	13	4	Vertical	14.43
16.17 GHz	56.786	74	-17.21	70	1.834	Vertical	16.14
12.30 GHz	54.805	74	-19.20	23	1.834	Horizontal	14.42

<b>Frequency</b>	<b>Level (dB<math>\mu</math>V/m)</b>	<b>Limit (dB<math>\mu</math>V/m)</b>	<b>Margin (dB)</b>	<b>Azimuth (<math>^{\circ}</math>)</b>	<b>Height (m)</b>	<b>Pol.</b>	<b>Correction (dB)</b>
16.20 GHz	57.609	74	-16.39	318	1.643	Horizontal	16.74

Avg

<b>Frequency</b>	<b>Level (dB<math>\mu</math>V/m)</b>	<b>Limit (dB<math>\mu</math>V/m)</b>	<b>Margin (dB)</b>	<b>Azimuth (<math>^{\circ}</math>)</b>	<b>Height (m)</b>	<b>Pol.</b>	<b>Correction (dB)</b>
12.40 GHz	41.342	54	-12.66	89	2.329	Vertical	13.99
14.82 GHz	42.375	54	-11.63	13	4	Vertical	14.43
16.17 GHz	43.689	54	-10.31	70	1.834	Vertical	16.14
12.30 GHz	41.656	54	-12.34	23	1.834	Horizontal	14.42
16.20 GHz	44.344	54	-9.66	318	1.643	Horizontal	16.74

**UNII-1 Spurious High Channel 1 – 17 GHz**

Previous Data as recorded in Report #: U7-Pro\_FCC\_15.407\_UNII-1\_02

Peak

Frequency	Level (dBμV/m)	Limit (dBμV/m)	Margin (dB)	Azimuth (°)	Height (m)	Pol.	Correction (dB)
10.47 GHz	52.904	74	-21.10	5	4	Vertical	8.01
11.91 GHz	58.719	74	-15.28	88	1.643	Vertical	10.05
15.74 GHz	64.193	74	-9.81	147	1.638	Vertical	11.14
10.47 GHz	52.743	74	-21.26	147	1.834	Horizontal	7.97
15.72 GHz	62.14	74	-11.86	129	1.833	Horizontal	11.19

Avg

Frequency	Level (dBμV/m)	Limit (dBμV/m)	Margin (dB)	Azimuth (°)	Height (m)	Pol.	Correction (dB)
10.47 GHz	39.40	54	-14.60	5	4	Vertical	8.01
11.91 GHz	51.94	54	-2.06	88	1.643	Vertical	10.05
15.74 GHz	51.12	54	-2.88	147	1.638	Vertical	11.14
10.47 GHz	40.02	54	-13.98	147	1.834	Horizontal	7.97
15.72 GHz	48.94	54	-5.06	129	1.833	Horizontal	11.19

**UNII-1 Spurious High Channel**

Data taken 8/19/2024

Peak

Frequency	Level (dBμV/m)	Limit (dBμV/m)	Margin (dB)	Azimuth (°)	Height (m)	Pol.	Correction (dB)
12.95 GHz	54.344	74	-19.66	11	2.325	Vertical	14.65
14.70 GHz	56.687	74	-17.31	143	2.142	Vertical	15.65
16.21 GHz	57.226	74	-16.77	1	3.153	Vertical	16.70
13.01 GHz	55.226	74	-18.77	27	3.802	Horizontal	15.171
16.10 GHz	55.962	74	-18.04	210	3.802	Horizontal	14.875

Avg

Frequency	Level (dBμV/m)	Limit (dBμV/m)	Margin (dB)	Azimuth (°)	Height (m)	Pol.	Correction (dB)
12.95 GHz	41.121	54	-12.88	11	2.325	Vertical	14.65
14.70 GHz	43.596	54	10.40	143	2.142	Vertical	15.65
16.21 GHz	44.143	54	-9.86	1	3.153	Vertical	16.70

---

<b>Frequency</b>	<b>Level (dB<math>\mu</math>V/m)</b>	<b>Limit (dB<math>\mu</math>V/m)</b>	<b>Margin (dB)</b>	<b>Azimuth (<math>^{\circ}</math>)</b>	<b>Height (m)</b>	<b>Pol.</b>	<b>Correction (dB)</b>
13.01 GHz	41.503	54	-12.50	27	3.802	Horizontal	15.171
16.10 GHz	42.627	54	-11.37	210	3.802	Horizontal	14.875

**UNII-5 Spurious Mid Channel 17 – 40 GHz**

Previous Data as recorded in Report #: U7-Pro\_FCC\_15.407\_UNII-5\_01

Peak

Frequency	Level (dB $\mu$ V/m)	Limit (dB $\mu$ V/m)	Margin (dB)	Azimuth (°)	Pol.	Correction (dB)
17.01 GHz	50.362	74	-23.64	259	Horizontal	-0.01

Avg

Frequency	Level (dB $\mu$ V/m)	Limit (dB $\mu$ V/m)	Margin (dB)	Azimuth (°)	Pol.	Correction (dB)
17.01	37.261	54	-16.74	259	Horizontal	-0.01

**UNII-5 Spurious Mid Channel**

Data Taken 8/23/2024

Peak

Frequency	Level (dB $\mu$ V/m)	Limit (dB $\mu$ V/m)	Margin (dB)	Azimuth (°)	Pol.	Correction (dB)
33.46 GHz	55.159	74	-18.84	255	Vertical	4.54
34.91 GHz	57.259	74	-16.74	243	Vertical	6.22
33.80 GHz	55.817	74	-18.18	39	Horizontal	5.27
34.95 GHz	57.085	74	-16.92	156	Horizontal	6.33

Avg

Frequency	Level (dB $\mu$ V/m)	Limit (dB $\mu$ V/m)	Margin (dB)	Azimuth (°)	Pol.	Correction (dB)
33.46 GHz	42.024	54	-11.98	255	Vertical	4.54
34.91 GHz	43.668	54	-10.33	243	Vertical	6.22
33.80 GHz	42.543	54	-11.46	39	Horizontal	5.27
34.95 GHz	43.939	54	-10.06	156	Horizontal	6.33

-- End of Test Report --



427 West 12800 South  
Draper, UT 84020

## Test Report Certification

<b>FCC ID</b>	SWX-U7PRO
<b>Equipment Under Test</b>	U7-Pro
<b>Test Report Serial Number</b>	TR8594_02
<b>Date of Test(s)</b>	8 September; 2 – 3 and 18 September 2023
<b>Report Issue Date</b>	13 December 2023

<b>Test Specification</b>	<b>Applicant</b>
47 CFR FCC Part 15, Subpart E	Ubiquiti Inc. 685 Third Avenue New York, NY 10017 U.S.A.



NVLAP LAB CODE 600241-0

---

## Certification of Engineering Report

This report has been prepared by Unified Compliance Laboratory (UCL) to document compliance of the device described below with the requirement of Federal Communication Commissions (FCC) Part 15, Subpart E. This report may be reproduced in full. Partial reproduction of this report may only be made with the written consent of the laboratory. The results in this report apply only to the sample tested.

<b>Applicant</b>	Ubiquiti Inc.
<b>Manufacturer</b>	Ubiquiti Inc.
<b>Brand Name</b>	UBIQUITI
<b>Model Number</b>	U7-Pro
<b>FCC ID</b>	SWX-U7PRO

On this 13<sup>th</sup> day of December 2023, I individually and for Unified Compliance Laboratory certify that the statements made in this engineering report are true, complete, and correct to the best of my knowledge and are made in good faith.

Although NVLAP has accredited the Unified Compliance Laboratory testing facilities, this report must not be used to claim product certification, approval, or endorsement by NVLAP, NIST or any agency of the U.S. federal government.

Unified Compliance Laboratory



Written By: Joseph W. Jackson



Reviewed By: Richard L. Winter



---

<b>Revision History</b>		
<b>Revision</b>	<b>Description</b>	<b>Date</b>
01	Original Report Release	26 October 2023
02	Updated Model number on Page 6	13 December 2023

## Table of Contents

1	Client Information.....	5
1.1	Applicant.....	5
1.2	Manufacturer.....	5
2	Equipment Under Test (EUT).....	6
2.1	Identification of EUT.....	6
2.2	Description of EUT.....	6
2.3	EUT and Support Equipment.....	6
2.4	Interface Ports on EUT.....	7
2.5	Operating Environment.....	7
2.6	Operating Modes.....	7
2.7	EUT Exercise Software.....	7
2.8	Block Diagram of Test Configuration.....	8
2.9	Modification Incorporated/Special Accessories on EUT.....	8
2.10	Deviation, Opinions Additional Information or Interpretations from Test Standard.....	8
3	Test Specification, Method and Procedures.....	9
3.1	Test Specification.....	9
3.2	Methods & Procedures.....	9
3.3	FCC Part 15, Subpart E.....	9
3.4	Results.....	9
3.5	Test Location.....	10
4	Test Equipment.....	11
4.1	Conducted Emissions at Mains Ports.....	11
4.2	Direct Connect at the Antenna Port Tests.....	11
4.3	Radiated Emissions.....	12
4.4	Equipment Calibration.....	13
4.5	Measurement Uncertainty.....	13
5	Test Results.....	14
5.1	§15.203 Antenna Requirements.....	14
5.2	Conducted Emissions at Mains Ports Data.....	14
5.3	§15.403(i) 26 dB Emissions Bandwidth.....	16
5.4	§15.407(a)(2) Maximum Average Output Power.....	17
5.5	§15.407(b) Spurious Emissions.....	19
5.6	§15.407(a) Maximum Power Spectral Density.....	31

# 1 Client Information

## 1.1 Applicant

<b>Company</b>	Ubiquiti Inc. 685 Third Avenue New York, NY 10017 U.S.A.
<b>Contact Name</b>	Alex Macon
<b>Title</b>	Compliance

## 1.2 Manufacturer

<b>Company</b>	Ubiquiti Inc. 685 Third Avenue New York, NY 10017 U.S.A.
<b>Contact Name</b>	Alex Macon
<b>Title</b>	Compliance

## 2 Equipment Under Test (EUT)

### 2.1 Identification of EUT

<b>Brand Name</b>	UBIQUITI
<b>Model Number</b>	U7-Pro
<b>Serial Number</b>	9AZ 003
<b>Dimensions (cm)</b>	20.6 x 20.6 x 4.6

### 2.2 Description of EUT

The U7-Pro is WiFi 7 access point that represents the next generation of competitively priced, prosumer wireless technology for home and enterprise users. The U7-Pro provides high aggregate throughput speeds. The U7-Pro transmit in the 2.4 GHz, 5 GHz and 6 GHz frequency bands and uses integrated antennas. The U7-Pro is powered from an 802.3at power adapter.

Band	WiFi Mode	Modulation Bandwidth	Modulation Type	Frequency (MHz)
UNII-1	a	20 MHz	OFDM	5180, 5200, 5210, 5240
	ax	20 MHz	HE	5180, 5200, 5210, 5240
	ax	40 MHz	HE	5190, 5230
	ax	80 MHz	HE	5210

This report covers the circuitry of the device subject to FCC Part 15, Subpart E. The circuitry of the device subject to FCC Part 15 Subpart B was found to be compliant and is covered under a separate Unified Compliance Laboratory test report.

### 2.3 EUT and Support Equipment

The EUT and support equipment used during the test are listed below.

<b>Brand Name Model Number Serial Number</b>	<b>Description</b>	<b>Name of Interface Ports / Interface Cables</b>
BN: UBIQUITI MN: U7-Pro SN: 9AZ 003	WiFi Access Point	See Section 2.4
BN: UBIQUITI MN: U-POE-at SN: N/A	PoE Power Adapter	Unshielded Cat 5e cable/1 meters
BN: Dell MN: XPS 13 SN: N/A	Laptop Personal Computer	Unshielded Cat 5e cable/1 meters

Notes: (1) EUT

(2) Interface port connected to EUT (See Section 2.4)

The support equipment listed above was not modified in order to achieve compliance with this standard.

## 2.4 Interface Ports on EUT

Name of Ports	No. of Ports Fitted to EUT	Cable Description/Length
AC Mains	1	3 conductor power cord/80 cm
POE (POE Injector)	1	Unshielded Cat 5e cable/8 meters
LAN (POE Injector)	1	Unshielded Cat 5e cable/1 meters

## 2.5 Operating Environment

<b>Power Supply</b>	120 Volts AC Mains to 48 Volts PoE
<b>AC Mains Frequency</b>	60 Hz
<b>Temperature</b>	23.7 – 25.4 °C
<b>Humidity</b>	28.4 – 33.9 %
<b>Barometric Pressure</b>	1009 mBar

## 2.6 Operating Modes

The U7-Pro was tested using test software in order to enable a constant transmission. The measurements within this report are corrected to reference a 100% duty cycle. All emission modes of 802.11 a/ax were investigated. All measurements are reported with the worst-case mode (802.11ax) unless otherwise stated.

## 2.7 EUT Exercise Software

EUT firmware version 1.0 was used to operate the transmitter using a constant transmit mode.

## 2.8 Block Diagram of Test Configuration

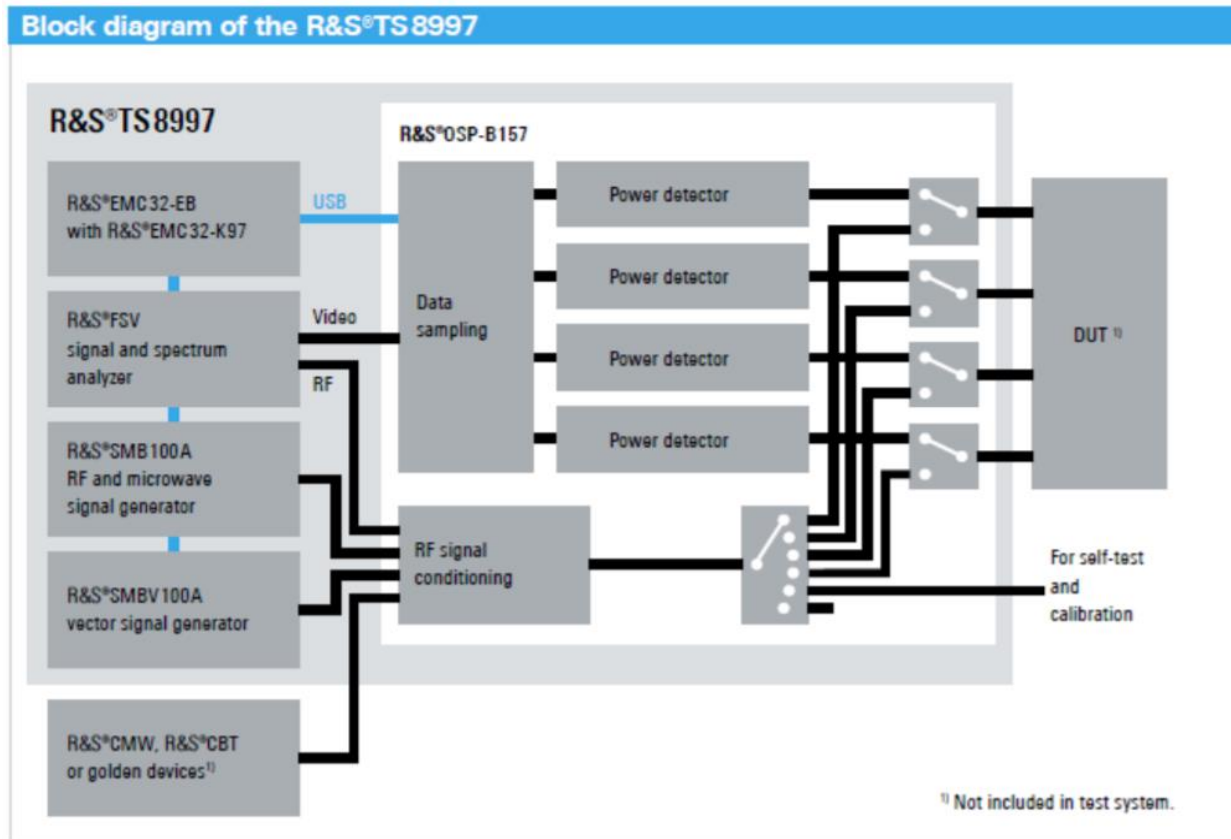

Diagram 1: Test Configuration Block Diagram

## 2.9 Modification Incorporated/Special Accessories on EUT

There were no modifications made to the EUT during testing to comply with the specification.

## 2.10 Deviation, Opinions Additional Information or Interpretations from Test Standard

There were no deviations, opinions, additional information or interpretations from the test specification.

## 3 Test Specification, Method and Procedures

### 3.1 Test Specification

<b>Title</b>	47 CFR FCC Part 15, Subpart E, Section 15.407 Limits and methods of measurement of radio interference characteristics of Unlicensed National Information Infrastructure Devices
<b>Purpose of Test</b>	The tests were performed to demonstrate initial compliance

### 3.2 Methods & Procedures

#### 3.2.1 47 CFR FCC Part 15 Section 15.407

See test standard for details.

### 3.3 FCC Part 15, Subpart E

#### 3.3.1 Summary of Tests

FCC Section	ISED Section	Environmental Phenomena	Frequency Range (MHZ)	Result
15.407(a)	N/A	Antenna requirements	Structural Requirement	Compliant
15.407(b)	RSS-Gen	Conducted Disturbance at Mains Port	0.15 to 30	Compliant
15.407(c)	RSS-247 §6.2.2, §6.2.3	Bandwidth Requirement	5180 to 5210	Compliant
15.407(e)	RSS-247 §6.2.2, §6.2.3	Peak Output Power	5180 to 5210	Compliant
15.407(f)	RSS-247 §6.2.2, §6.2.3	Antenna Conducted Spurious Emissions	0.009 to 40000	N/A
15.407(g)	RSS-247 §6.2.2, §6.2.3	Radiated Spurious Emissions	0.009 to 40000	Compliant
15.407(h)	RSS-247 §6.2.2, §6.2.3	Peak Power Spectral Density	5180 to 5210	Compliant

The testing was performed according to the procedures in ANSI C63.10-2013, KDB 789033 and 47 CFR Part 15. Where applicable, KDB 662911 was followed to sum required measurements.

### 3.4 Results

In the configuration tested, the EUT complied with the requirements of the specification.

### **3.5 Test Location**

Testing was performed at the Unified Compliance Laboratory 3-Meter and 10-Meter chambers located at 427 West 12800 South, Draper, UT 84020. Unified Compliance Laboratory is accredited by National Voluntary Laboratory Accreditation Program (NVLAP); NVLAP Code 600241-0 which is effective until 30 June 2024. This site has also been registered with Innovations, Science and Economic Development (ISED) department as was accepted under Appendix B, Phase 1 procedures of the APEC Tel MRA for Canadian recognition. ISED No.: 25346, effective until 30 June 2024.

Unified Compliance Laboratory has been assigned Designation Number US5037 by the FCC and Conformity Assessment Number US0223 by ISED.



## 4 Test Equipment

### 4.1 Conducted Emissions at Mains Ports

Type of Equipment	Manufacturer	Model Number	Asset Number	Date of Last Calibration	Due Date of Calibration
EMI Receiver	AFJ	FFT3010	UCL-6754	2/22/2023	2/22/2024
LISN	AFJ	LS16C/10	UCL-6749	12/6/2021	12/6/2023
ISN	Teseq	ISN T800	UCL-2974	6/27/2022	6/27/2024
LISN	Com-Power	LIN-120C	UCL-2612	1/24/2023	1/24/2024
AC Power Source	Laplace Instruments	AC1000A	UCL-2857	N/A	N/A
Test Software	UCL	Revision 1	UCL-3107	N/A	N/A

Table 1: List of equipment used for Conducted Emissions Testing at Mains Port

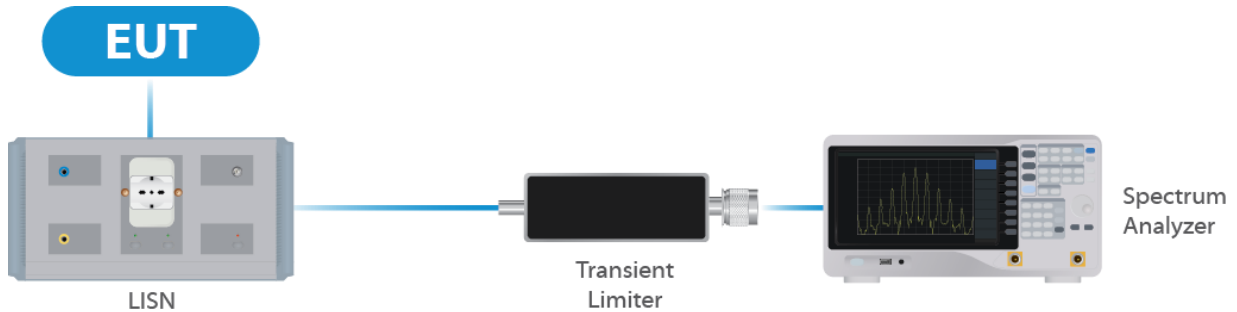
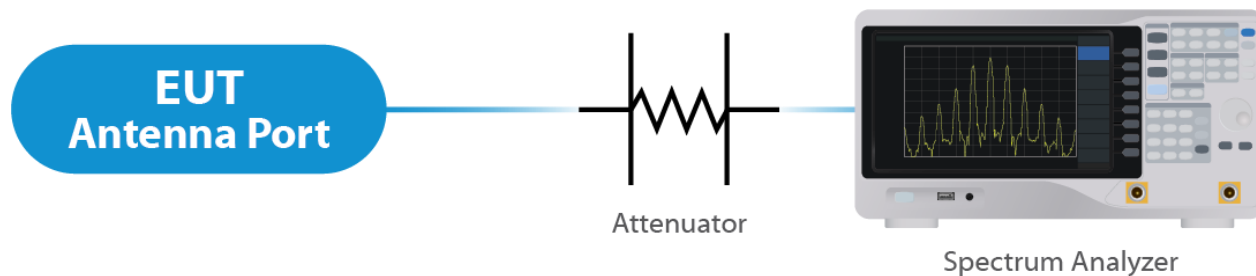

Figure 1: Conducted Emissions Test

### 4.2 Direct Connect at the Antenna Port Tests

Type of Equipment	Manufacturer	Model Number	Asset Number	Date of Last Calibration	Due Date of Calibration
Spectrum Analyzer	R&S	FSV40	UCL-2861	11/7/2022	11/7/2023
Signal Generator	R&S	SMB100A	UCL-2864	N/A	N/A
Vector Signal Generator	R&S	SMBV100A	UCL-2873	N/A	N/A
Switch Extension	R&S	OSP-B157WX	UCL-2867	2/22/2023	2/22/2024
Switch Extension	R&S	OSP-150W	UCL-2870	2/22/2023	2/22/2024

Table 2: List of equipment used for Direct Connect at the Antenna Port



**Figure 2: Direct Connect at the Antenna Port Test**

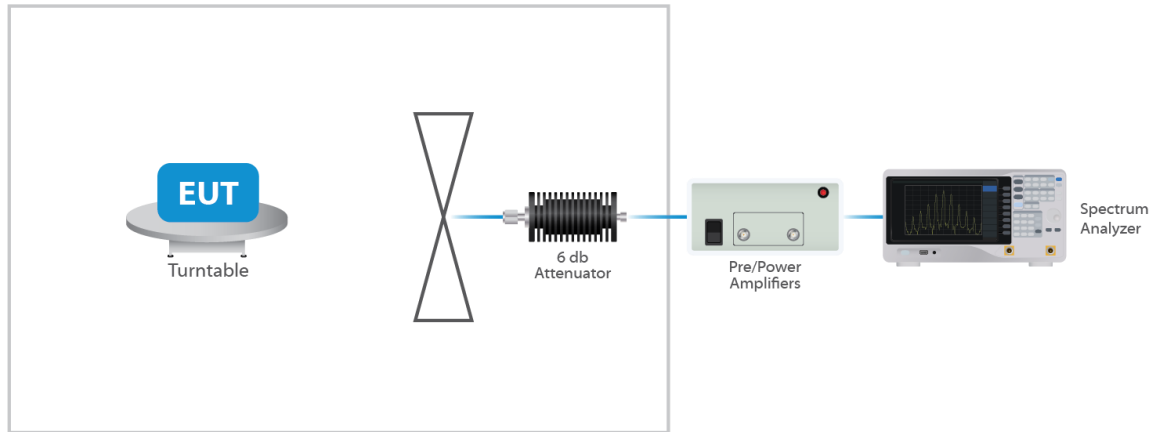

**Figure 3: Output Power Measurement**

### 4.3 Radiated Emissions

Type of Equipment	Manufacturer	Model Number	Asset Number	Date of Last Calibration	Due Date of Calibration
EMI Receiver	Keysight	N9038A	UCL-2778	1/27/2023	1/27/2024
Pre-Amplifier 9 kHz – 1 GHz	Sonoma Instruments	310N	UCL-2889	10/7/2021	10/7/2023
Broadband Antenna	Scwarzbeck	VULB 9163	UCL-3062	2/22/2023	2/22/2025
Broadband Antenna	Scwarzbeck	VULB 9163	UCL-3071	1/11/2023	1/11/2025
Double Ridge Horn Antenna	Scwarzbeck	BBHA 9120D	UCL-3065	9/22/2022	9/22/2024
Log Periodic	Scwarzbeck	STLP 9129	UCL-3068	1/27/2023	1/27/2025
15 - 40 GHz Horn Antenna	Scwarzbeck	BBHA 9170	UCL-2487	6/09/2022	6/09/2024
1 – 18 GHz Amplifier	Com-Power	PAM 118A	UCL-3833	12/9/2022	12/9/2023
Test Software	UCL	Revision 1	UCL-3108	N/A	N/A

**Table 3: List of equipment used for Radiated Emissions**



**Figure 4: Radiated Emissions Test**

### 4.4 Equipment Calibration

All applicable equipment is calibrated using either an independent calibration laboratory or Unified Compliance Laboratory personnel at intervals defined in ANSI C63.4:2014 following outlined calibration procedures. All measurement instrumentation is traceable to the National Institute of Standards and Technology (NIST). Supporting documentation relative to traceability is on file and is available for examination upon request.

### 4.5 Measurement Uncertainty

Test	Uncertainty ( $\pm$ dB)	Confidence (%)
Conducted Emissions	1.44	95
Radiated Emissions (9 kHz to 30 MHz)	2.50	95
Radiated Emissions (30 MHz to 1 GHz)	4.38	95
Radiated Emissions (1 GHz to 18 GHz)	4.37	95
Radiated Emissions (18 GHz to 40 GHz)	3.93	95
<b>Direct Connect Tests</b>	<b>K Factor</b>	<b>Value</b>
Emissions Bandwidth	2	2.0%
Output Power	2	1.0 dB
Peak Power Spectral Density	2	1.3 dB
Band Edge	2	0.8 dB
Transmitter Spurious Emissions	2	1.8 dB

## 5 Test Results

### 5.1 §15.203 Antenna Requirements

The EUT uses an integrated antenna structure. Per the manufacturer, the maximum gain of the antenna per chain is 6 dBi. This is an 802.11 device and utilizes CDD as described in KDB 662911 D01. The antenna is not user replaceable.

For power measurements on IEEE 802.11 devices, Array Gain = 0 dB for NANT ≤ 4;

For PSD measurements when Nss=1: Array Gain = 10 log(Nant/Nss) dB = 3.01dB

#### Results

The EUT complied with the specification

### 5.2 Conducted Emissions at Mains Ports Data

#### 5.2.1 Line

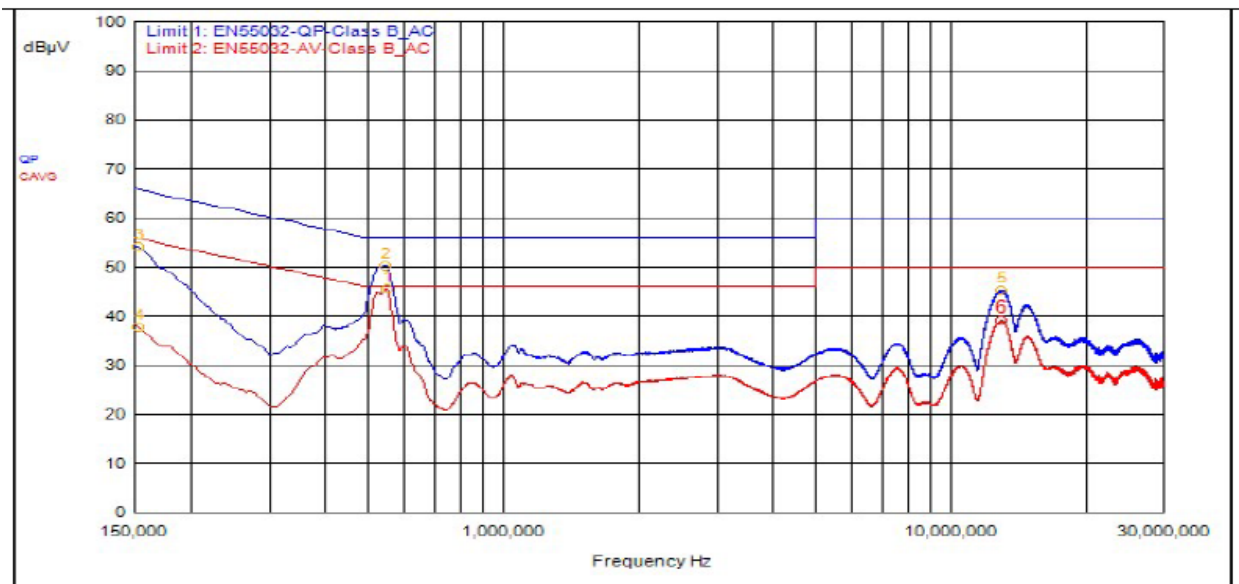

ID	Frequency	Probe	Cable	Atten.	Detector	Meter Read	Meas Level	Limit 1	Limit 1 Dist.	Limit 2	Limit 2 Dist.	P/F
MU	MHz	dB	dB	dB	Type	dBµV	dBµV	dBµV	dB	dBµV	dB	P/F
2	546,000kHz	12.23	0.00		QPeak	38.16	50.39	56.00	-5.61			
3	153,000kHz	12.26	0.00		QPeak	41.82	54.08	65.84	-11.76			
5	12.996	12.27	0.00		QPeak	33.02	45.29	60.00	-14.71			
1	549,000kHz	12.23	0.00		C_AVG	33.22	45.45			46.00	-0.55	
4	153,000kHz	12.26	0.00		C_AVG	25.61	37.87			55.84	-17.96	
6	12.981	12.27	0.00		C_AVG	26.77	39.04			50.00	-10.96	

### 5.2.2 Neutral

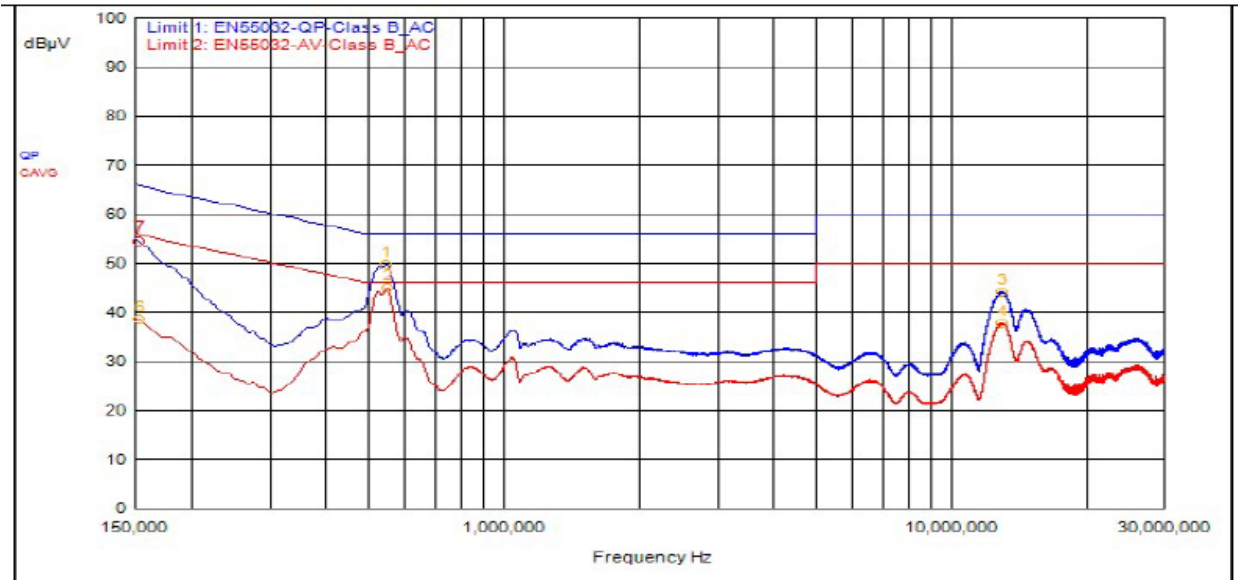

ID	Frequency	Probe	Cable	Atten.	Detector	Meter Read	Meas Level	Limit 1	Limit 1 Dist.	Limit 2	Limit 2 Dist.	P/F
MU	MHz	dB	dB	dB	Type	dBµV	dBµV	dBµV	dB	dBµV	dB	P/F
1	546,000kHz	12.18	0.00		QPeak	37.58	49.76	56.00	-6.24			
5	150,000kHz	12.21	0.00		QPeak	42.89	55.10	66.00	-10.90			
7	153,000kHz	12.21	0.00		QPeak	42.12	54.33	65.84	-11.50			
3	12.993	12.29	0.00		QPeak	31.97	44.26	60.00	-15.74			
2	549,000kHz	12.18	0.00		C_AVG	32.76	44.94			46.00	-1.06	
4	12.966	12.29	0.00		C_AVG	25.48	37.77			50.00	-12.23	
6	153,000kHz	12.21	0.00		C_AVG	26.39	38.60			55.84	-17.24	

### Result

The EUT complied with the specification limit.

### 5.3 §15.403(i) 26 dB Emissions Bandwidth

Nominal BW (MHz)	Frequency (MHz)	99% Bandwidth (MHz)	Emissions 26 dB Bandwidth (MHz)
ax 20 MHz	5180	16.8	22.4
ax 20 MHz	5210	19.7	35.6
ax 20 MHz	5240	18.1	33.9
ax 20 MHz	5180	19.1	22.5
ax 20 MHz	5210	19.1	24.3
ax 20 MHz	5240	19.2	39.1
ax 40 MHz	5190	38.0	41.9
ax 40 MHz	5230	38.3	43.4
ax 80 MHz	5210	78.0	91.5

#### Result

All chains were tested and the highest bandwidth per chain is reported above.

The 26 dB bandwidths are reported for information purposes. Please see Annex for all bandwidth measurements.

## 5.4 §15.407(a)(2) Maximum Average Output Power

All chains were measured and summed under the guidance of KDB 789033 Section II. E.2. and KDB 66291 D01. Please see associated annex for details on instrument settings.

The maximum average RF conducted output power measured for this device was 27.32 dBm or 539.51 mW. The limit is 30 dBm, or 1 Watt when using an antenna with 6 dBi (indoor/outdoor access point) or less gain. The antenna has a gain of 6.0 dBi.

Modulation (BW)	Frequency (MHz)	Data Rate	TP Setting	Conducted Output Power	Measured EIRP	Measured PSD
a 20 MHz	5180	Mcs0_Nss2	20	22.46	28.46	9.68
a 20 MHz	5210	Mcs0_Nss2	25	26.98	32.98	14.21
a 20 MHz	5240	Mcs0_Nss2	25	27.28	33.28	14.43
ax 20 MHz	5180	Mcs0_Nss2	20	22.48	28.48	9.25
ax 20 MHz	5210	Mcs0_Nss2	24	26.18	32.18	12.86
ax 20 MHz	5240	Mcs0_Nss2	25	27.32	33.32	13.97
ax 40 MHz	5190	Mcs0_Nss2	18	20.53	26.53	4.37
ax 40 MHz	5230	Mcs0_Nss2	21	23.70	29.70	7.20
ax 80 MHz	5210	Mcs0_Nss2	19	21.28	27.28	1.75

Modulation (BW)	Frequency (MHz)	Data Rate	TP Setting	Conducted Output Power	Measured EIRP	Measured PSD
a 20 MHz	5180	Mcs0_Nss1	20	22.46	28.46	9.68
a 20 MHz	5210	Mcs0_Nss1	25	25.98	31.98	14.21
a 20 MHz	5240	Mcs0_Nss1	25	26.28	32.28	14.43
ax 20 MHz	5180	Mcs0_Nss1	20	22.48	28.48	9.25
ax 20 MHz	5210	Mcs0_Nss1	24	26.18	32.18	12.86
ax 20 MHz	5240	Mcs0_Nss1	25	27.32	33.32	13.97
ax 40 MHz	5190	Mcs0_Nss1	18	20.53	26.53	4.37
ax 40 MHz	5230	Mcs0_Nss1	21	23.70	29.70	7.20
ax 80 MHz	5210	Mcs0_Nss1	19	21.28	27.28	1.75

### Result

In the configuration tested, the maximum summed average RF output power was less than 1 watt; therefore, the EUT complied with the requirements of the specification (see spectrum analyzer plots in attached Annex).

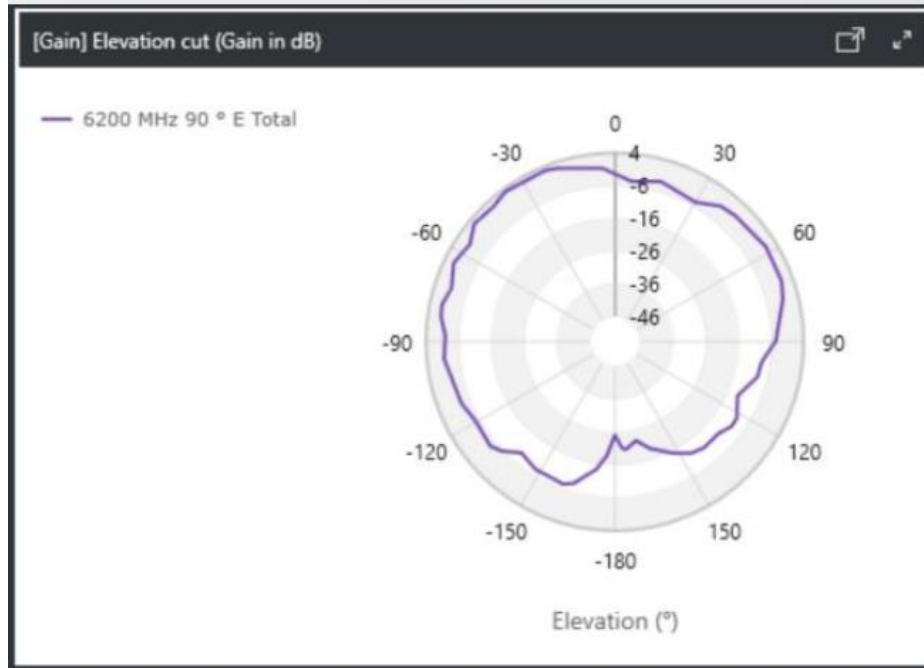

**Plot 1: Elevation Plot Greater Than 30-Degrees From Horizon**



## **5.5 §15.407(b) Spurious Emissions**

### **5.5.1 Conducted Spurious Emissions**

The frequency range from the lowest frequency generated or used in the device to the tenth harmonic of the highest fundamental frequency was investigated to measure any antenna-conducted emissions. The graphs show the measurement data from spurious emissions noted across the frequency range when transmitting at the lowest frequency, middle frequency and upper frequency. Shown below are plots with the EUT turned to the upper and lower channels with the antenna gain of 6 dBi accounted for. These demonstrate compliance with the provisions of this section at the band edges.

The emissions must be remain below -27 dBm EIRP.

#### **Result**

Conducted spurious emissions were below -27 dBm; therefore, the EUT complies with the specification.

### **5.5.2 Radiated Spurious Emissions in the Restricted Bands of § 15.205**

The EUT uses various power settings based on the channel in use. In order to reduce test time, the radiated spurious emissions at the lowest, middle, and highest channel were measured at the maximum power of TP25, as this setting was found to be worst case for spurious emissions. Power was subsequently reduced during in-band and band edge testing. The band edge at the restricted band ending at 5150 MHz was measured using radiated measurement or conducted at the antenna port methods. [For radiated] All emissions modes were tested, and the worst-case measurement are shown below. For frequencies above 1 GHz, a measurement of 3 meters was used. For frequencies below 1 GHz, a measurement distance of 10 meters was used.

Correction Factor = Antenna Factor + Cable Loss - Pre-Amplifier Gain, and is added to the Receiver reading.

#### **Result**

All emissions in the restricted bands of § 15.205 met the limits specified in § 15.209; therefore, the EUT complies with the specification. All emissions me the limits specified in § 15.407(b). Representative band edge plots are included in this report. See Annex for Conducted Band edge plots.

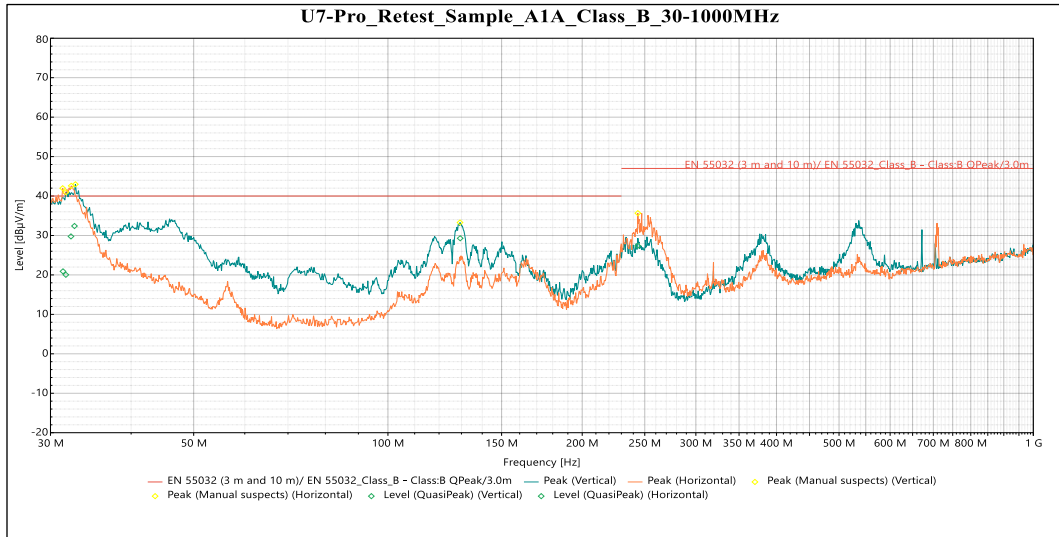

**QuasiPeak**

Frequency	Level (dBµV/m)	Limit (dBµV/m)	Margin	Azimuth (°)	Height	Pol.	Correction (dB)
31.692 MHz	20.029	40	-19.971	69	2.759	Vertical	-8.569
32.681 MHz	32.403	40	-7.597	199	1	Vertical	-9.148
129.41 MHz	29.287	40	-10.713	341	1.138	Vertical	-14.232
31.369 MHz	20.912	40	-19.088	251	1.143	Horizontal	-8.51
32.273 MHz	29.759	40	-10.241	50	3.298	Horizontal	-8.831
243.82 MHz	27.376	47	-19.624	278	1.52	Horizontal	-15.915

**Table 4: Radiated Emissions 30 – 1000 MHz**

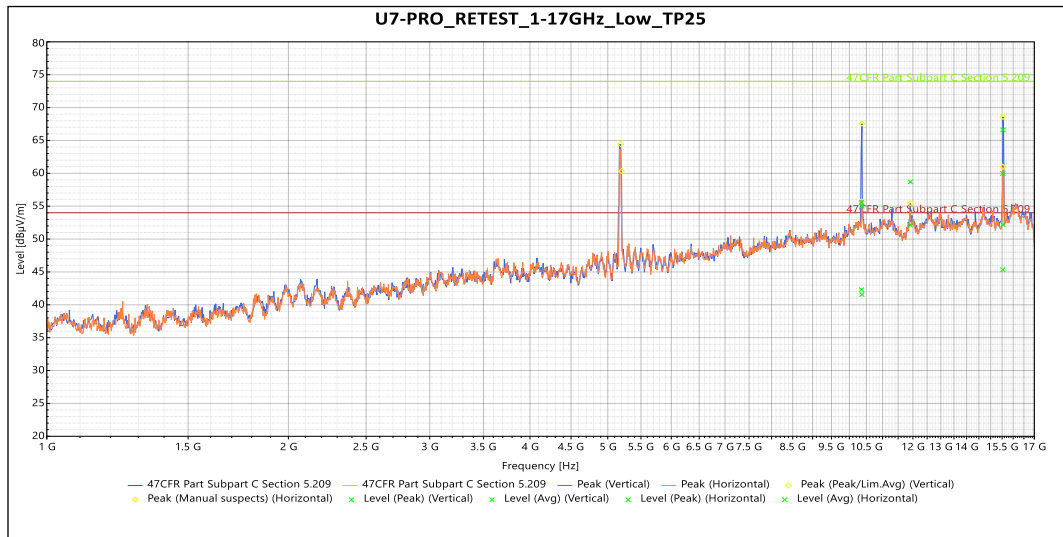

**Peak**

Frequency	Level (dBµV/m)	Limit (dBµV/m)	Margin (dB)	Azimuth (°)	Height (m)	Pol.	Correction (dB)
10.367 GHz	55.017	74	-18.983	136	1.643	Vertical	8.553
11.91 GHz	58.708	74	-15.292	87	1.638	Vertical	10.047
15.538 GHz	66.609	74	-7.391	124	2.645	Vertical	10.592
10.354 GHz	55.596	74	-18.404	162	2.645	Horizontal	8.387
15.53 GHz	59.965	74	-14.035	148	3.154	Horizontal	10.603

**Avg**

Frequency	Level (dBµV/m)	Limit (dBµV/m)	Margin (dB)	Azimuth (°)	Height (m)	Pol.	Correction (dB)
10.367 GHz	41.564	54	-12.436	136	1.643	Vertical	8.553
11.91 GHz	52.136	54	-1.864	87	1.638	Vertical	10.047
15.538 GHz	52.195	54	-1.805	124	2.645	Vertical	10.592
10.354 GHz	42.29	54	-11.71	162	2.645	Horizontal	8.387
15.53 GHz	45.337	54	-8.663	148	3.154	Horizontal	10.603

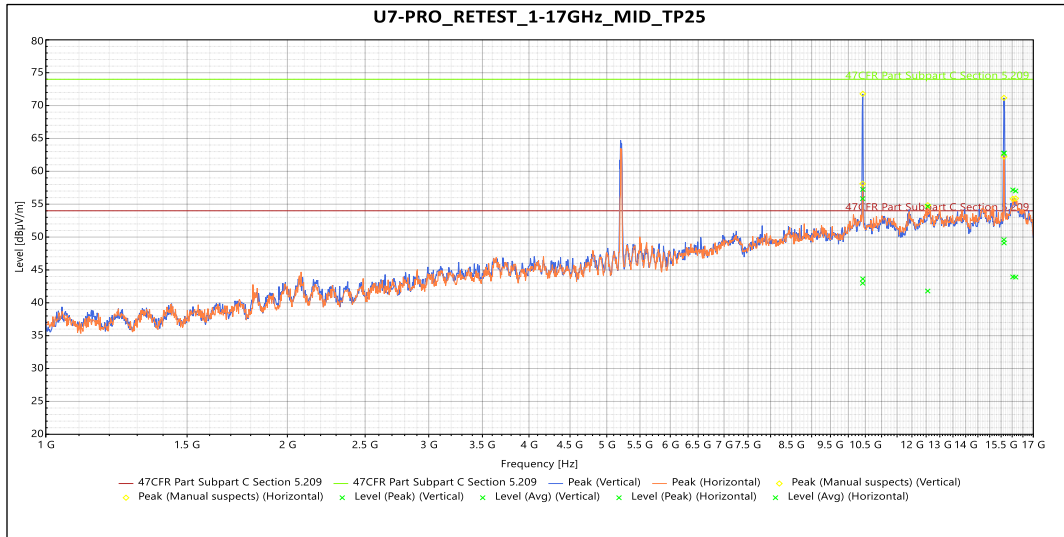
**Table 5: Radiated Emissions 1 – 17 GHz on the Lowest Frequency 5180 MHz**



**Peak**

Frequency	Level (dBµV/m)	Limit (dBµV/m)	Margin (dB)	Azimuth (°)	Height (m)	Pol.	Correction (dB)
10.424 GHz	57.241	74	-16.759	162	2.142	Vertical	8.686
15.626 GHz	62.739	74	-11.261	140	2.65	Vertical	10.663
16.161 GHz	57.01	74	-16.99	287	4	Vertical	13.038
10.419 GHz	55.85	74	-18.15	124	3.307	Horizontal	8.741
12.558 GHz	54.672	74	-19.328	342	2.325	Horizontal	10.128
15.631 GHz	62.776	74	-11.224	126	3.154	Horizontal	10.685
16.034 GHz	57.171	74	-16.829	332	2.325	Horizontal	12.42

**Avg**

Frequency	Level (dBµV/m)	Limit (dBµV/m)	Margin (dB)	Azimuth (°)	Height (m)	Pol.	Correction (dB)
10.424 GHz	43.64	54	-10.36	162	2.142	Vertical	8.686
15.626 GHz	49.599	54	-4.401	140	2.65	Vertical	10.663
16.161 GHz	43.911	54	-10.089	287	4	Vertical	13.038
10.419 GHz	42.977	54	-11.023	124	3.307	Horizontal	8.741
12.558 GHz	41.791	54	-12.209	342	2.325	Horizontal	10.128
15.631 GHz	49.103	54	-4.897	126	3.154	Horizontal	10.685
16.034 GHz	43.936	54	-10.064	332	2.325	Horizontal	12.42

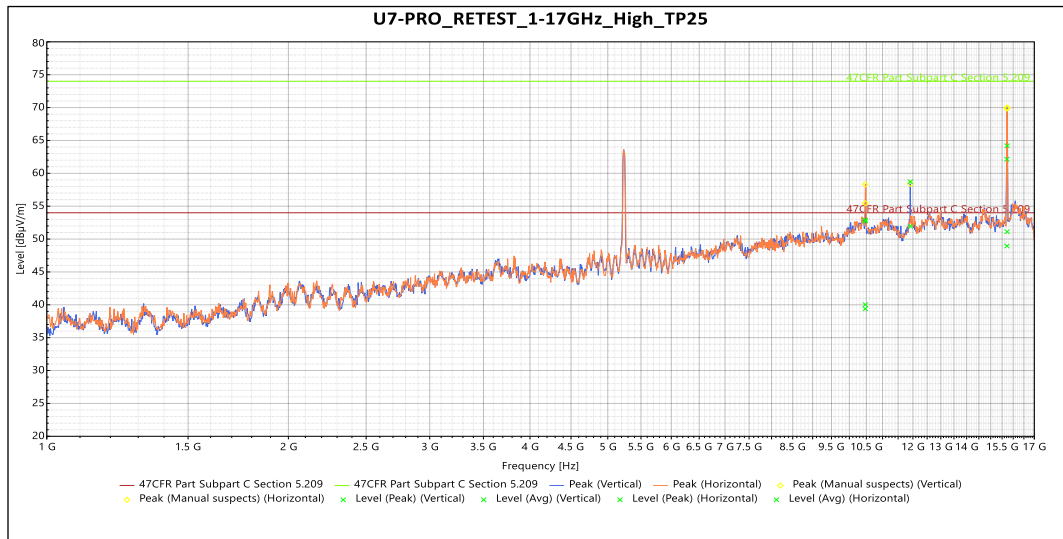
**Table 6: Transmitting on the Middle Frequency 5200 MHz**



**Peak**

Frequency	Level (dBµV/m)	Limit (dBµV/m)	Margin (dB)	Azimuth (°)	Height (m)	Pol.	Correction (dB)
10.468 GHz	52.904	74	-21.096	5	4	Vertical	8.007
11.91 GHz	58.719	74	-15.281	88	1.643	Vertical	10.047
15.724 GHz	64.193	74	-9.807	147	1.638	Vertical	11.138
10.47 GHz	52.743	74	-21.257	147	1.834	Horizontal	7.971
15.715 GHz	62.14	74	-11.86	129	1.833	Horizontal	11.192

**Avg**

Frequency	Level (dBµV/m)	Limit (dBµV/m)	Margin (dB)	Azimuth (°)	Height (m)	Pol.	Correction (dB)
10.468 GHz	39.4	54	-14.6	5	4	Vertical	8.007
11.91 GHz	51.942	54	-2.058	88	1.643	Vertical	10.047
15.724 GHz	51.119	54	-2.881	147	1.638	Vertical	11.138
10.47 GHz	40.016	54	-13.984	147	1.834	Horizontal	7.971
15.715 GHz	48.941	54	-5.059	129	1.833	Horizontal	11.192

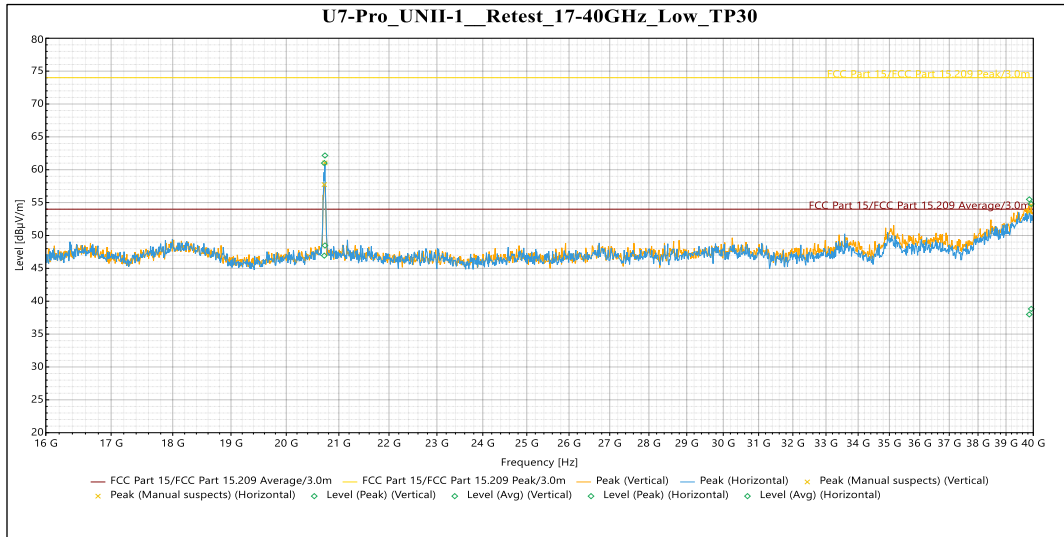
**Table 7: Transmitting on the Highest Frequency 5240 MHz**



**Peak**

Frequency	Level (dBµV/m)	Limit (dBµV/m)	Margin (dB)	Azimuth (°)	Pol.	Correction (dB)
20.718 GHz	61.009	74	-12.991	46	Vertical	-0.381
39.924 GHz	54.801	74	-19.199	225	Vertical	5.178
20.731 GHz	62.172	74	-11.828	60	Horizontal	-0.391
39.852 GHz	55.494	74	-18.506	187	Horizontal	5.234

**Avg**

Frequency	Level (dBµV/m)	Limit (dBµV/m)	Margin (dB)	Azimuth (°)	Pol.	Correction (dB)
20.718 GHz	46.928	54	-7.072	46	Vertical	-0.381
39.924 GHz	38.832	54	-15.168	225	Vertical	5.178
20.731 GHz	48.484	54	-5.516	60	Horizontal	-0.391
39.852 GHz	37.988	54	-16.012	187	Horizontal	5.234

**Table 8: Radiated Emissions 17 – 40 GHz on the Lowest Frequency 5180 MHz (worse case)**

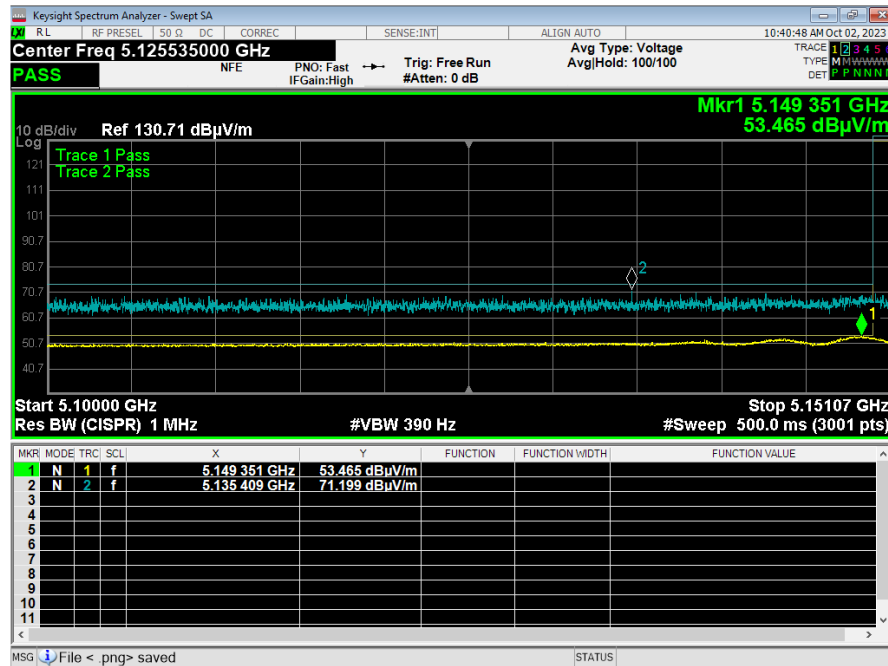

**Graph 5: Band Edge a Mode 20 MHz – 5180 MHz**

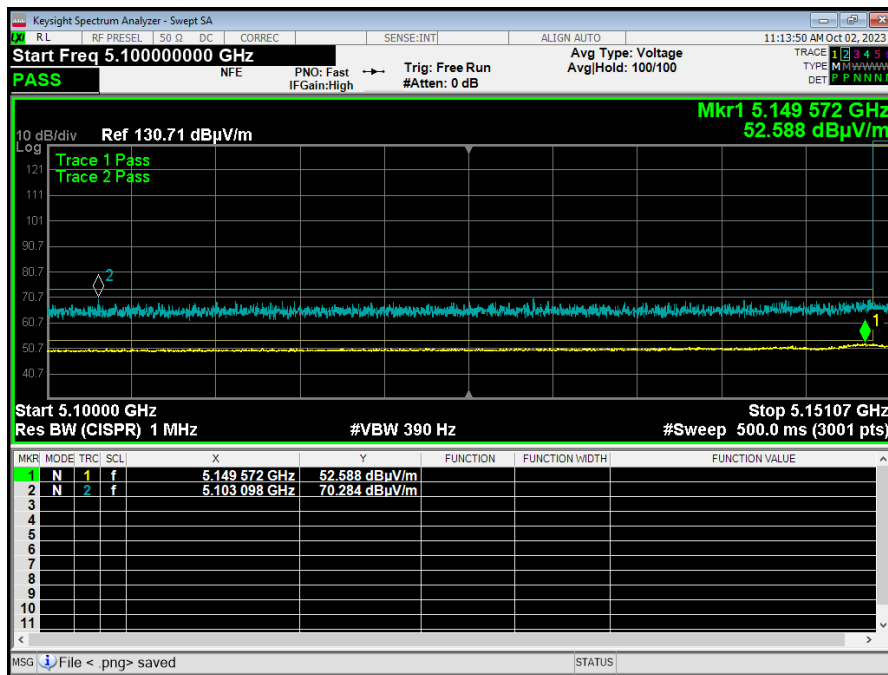

**Graph 6: Band Edge a Mode 20 MHz - 5200 MHz**

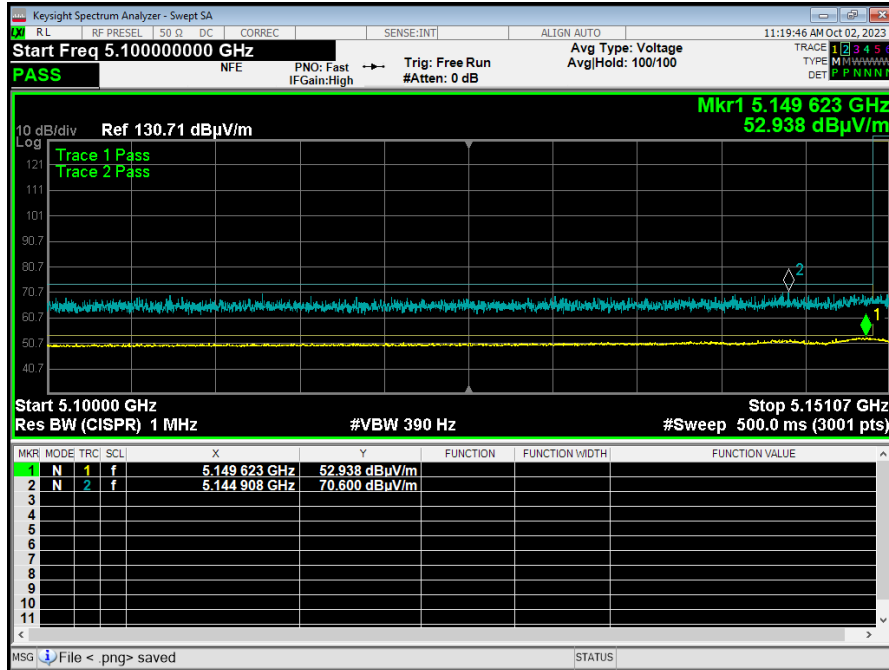

**Graph 7: Band Edge a Mode 20 MHz – 5210 MHz**

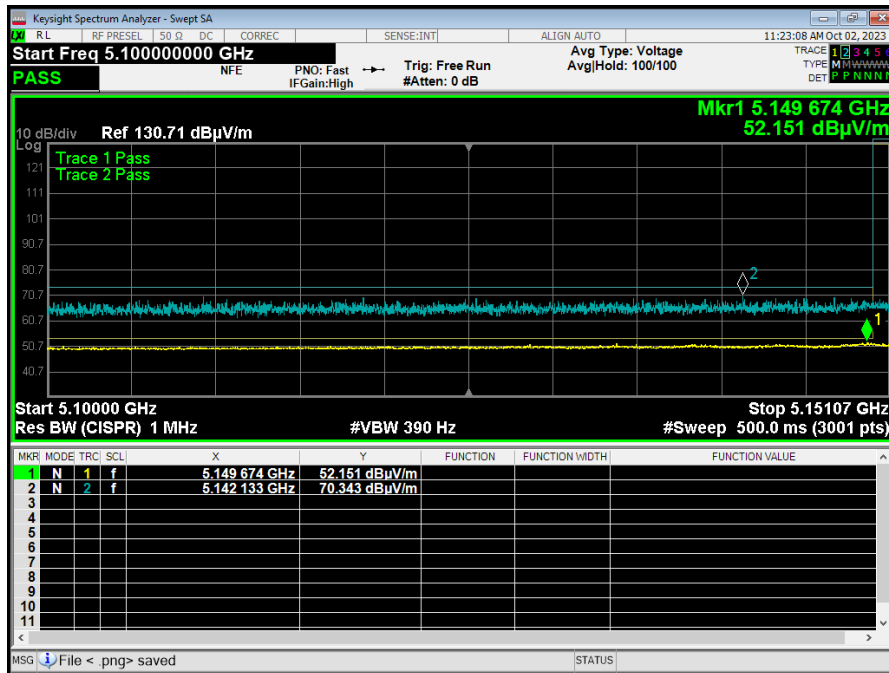

**Graph 8: Band Edge a Mode 20 MHz - 5240 MHz**



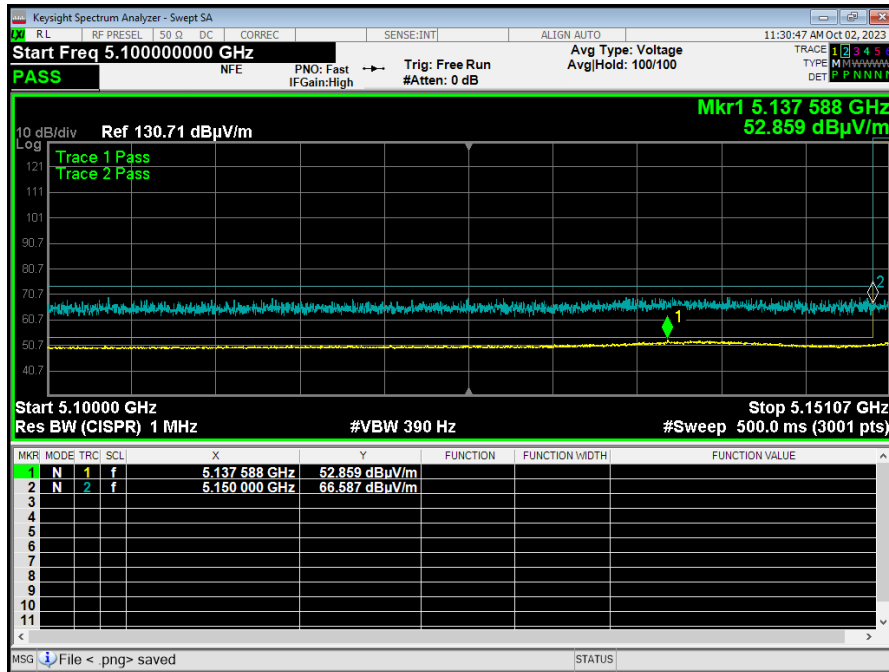

Graph 9: Band Edge ax Mode 20 MHz - 5180 MHz

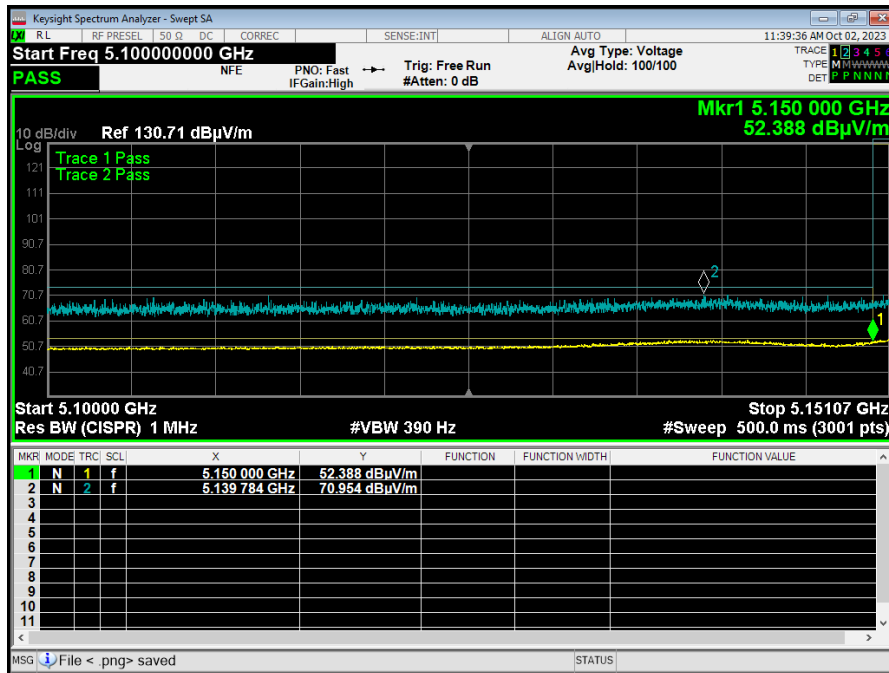

Graph 10: Band Edge ax Mode 20 MHz – 5200 MHz

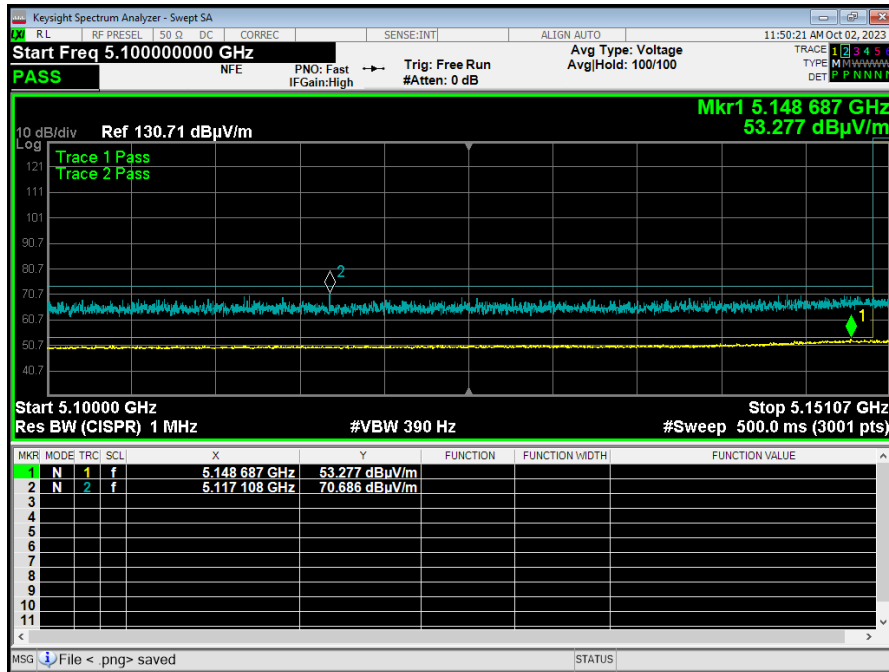

Graph 11: Band Edge ax Mode 20 MHz - 5210 MHz

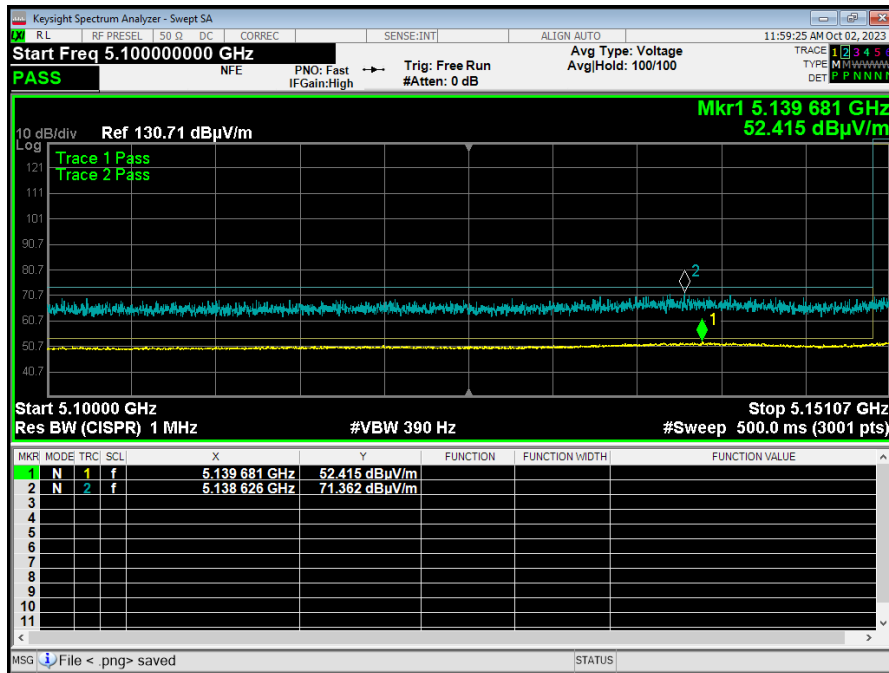

Graph 12: Band Edge ax Mode 20 MHz - 5240 MHz

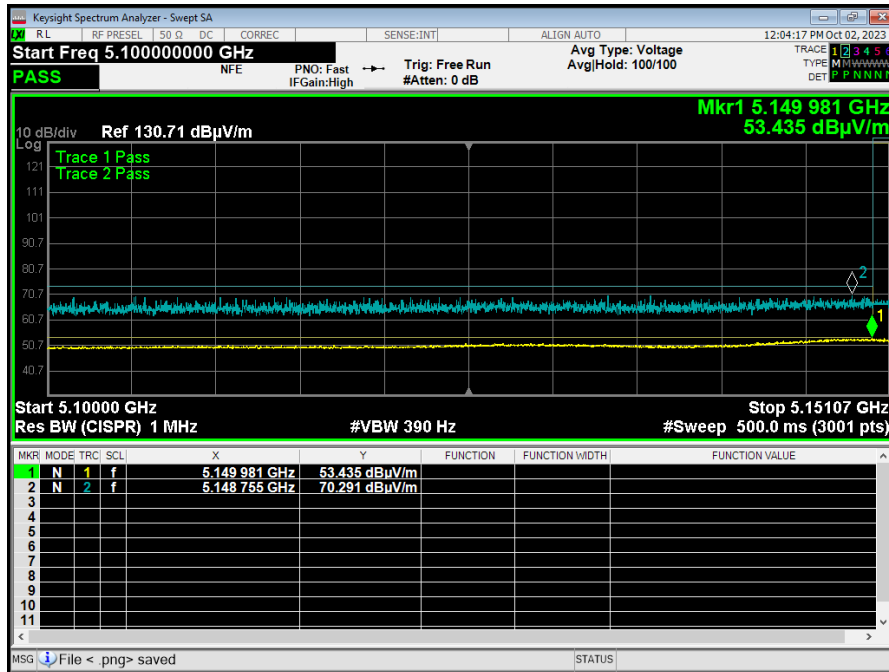

Graph 13: Band Edge ax Mode 40 MHz - 5190 MHz

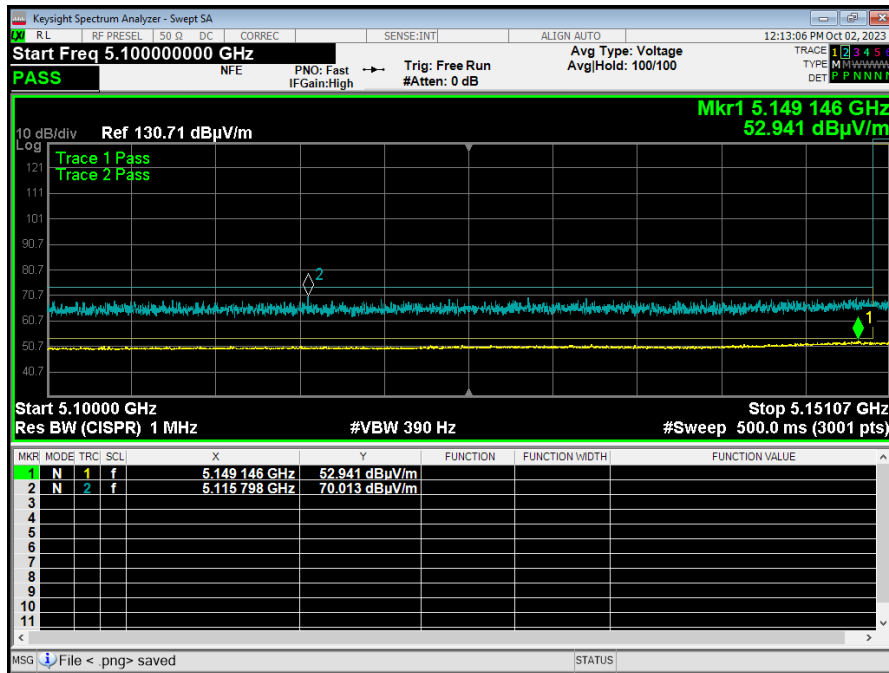

Graph 14: Band Edge ax Mode 40 MHz - 5230 MHz

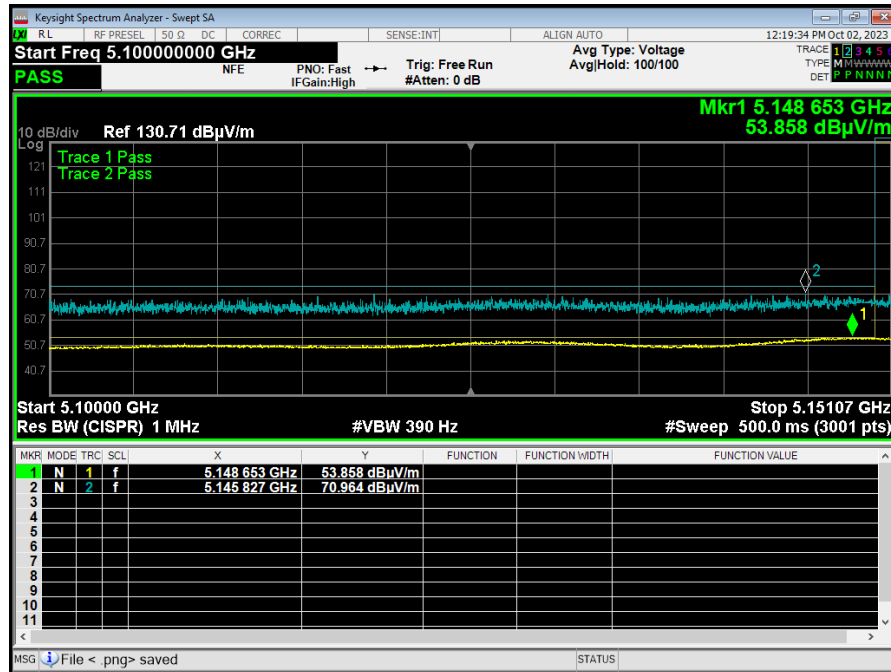

Graph 15: Band Edge ax Mode 40 MHz - 5210 MHz

## 5.6 §15.407(a) Maximum Power Spectral Density

All chains were measured and summed under the guidance of KDB 789033 Section II. F. and KDB 66291 D01. Please see associated annex for details on instrument settings.

The maximum average power spectral density conducted from the intentional radiator of the antenna shall not be greater than 17 dBm in any 1 MHz band during any time interval of continuous transmission.

As per KDB 662911, when the EUT is using spatial-multiplexing in HT to HE modes, there is not additional array gain to accommodate. When the EUT uses Nss=1 data rates, the antenna gain is 6 dBi + Array gain of 3.01 dB which is a total of 9.01 dBi.

Results of this testing are summarized.

Modulation (BW)	Frequency (MHz)	Data Rate	TP Setting	Measured PSD
a 20 MHz	5180	Mcs0_Nss2	20	9.68
a 20 MHz	5210	Mcs0_Nss2	25	14.21
a 20 MHz	5240	Mcs0_Nss2	25	14.43
ax 20 MHz	5180	Mcs0_Nss2	20	9.25
ax 20 MHz	5210	Mcs0_Nss2	24	12.86
ax 20 MHz	5240	Mcs0_Nss2	25	13.97
ax 40 MHz	5190	Mcs0_Nss2	18	4.37
ax 40 MHz	5230	Mcs0_Nss2	21	7.20
ax 80 MHz	5210	Mcs0_Nss2	19	1.75

Modulation (BW)	Frequency (MHz)	Data Rate	TP Setting	Measured PSD
a 20 MHz	5180	Mcs0_Nss1	20	9.68
a 20 MHz	5210	Mcs0_Nss1	25	14.21
a 20 MHz	5240	Mcs0_Nss1	25	14.43
ax 20 MHz	5180	Mcs0_Nss1	20	9.25
ax 20 MHz	5210	Mcs0_Nss1	24	12.86
ax 20 MHz	5240	Mcs0_Nss1	25	13.97
ax 40 MHz	5190	Mcs0_Nss1	18	4.37
ax 40 MHz	5230	Mcs0_Nss1	21	7.20
ax 80 MHz	5210	Mcs0_Nss1	19	1.75

**Result**

The maximum summed average power spectral density was less than the limit of 17dBm; therefore, the EUT complies with the specification.

-- End of Test Report --