



427 West 12800 South
Draper, UT 84020

Test Report Certification

FCC ID	SWX-U7PROP
Canada ID	6545A-U7PROP
Equipment Under Test	U7 Pro
Test Report Serial Number	TR9343_05
Date of Test(s)	19, 23, 29 and 30 August 2024
Report Issue Date	3 September 2024

Test Specification	Applicant
47 CFR FCC Part 15, Subpart E RSS-GEN	Ubiquiti Inc. 685 Third Avenue New York, NY 10019 U.S.A.



NVLAP LAB CODE 600241-0

Certification of Engineering Report

This report has been prepared by Unified Compliance Laboratory (UCL) to document compliance of the device described below with the requirement of Federal Communication Commissions (FCC) Part 15, Subpart E. This report may be reproduced in full. Partial reproduction of this report may only be made with the written consent of the laboratory. The results in this report apply only to the sample tested.

Applicant	Ubiquiti Inc.
Manufacturer	Ubiquiti Inc.
Brand Name	UBIQUITI
Model Number	U7 Pro
FCC ID	SWX-U7PROP
Canada ID	6545A-U7PROP

On this 3rd day of September 2024, I individually and for Unified Compliance Laboratory certify that the statements made in this engineering report are true, complete, and correct to the best of my knowledge and are made in good faith.

Although NVLAP has accredited the Unified Compliance Laboratory testing facilities, this report must not be used to claim product certification, approval, or endorsement by NVLAP, NIST or any agency of the U.S. federal government.

Unified Compliance Laboratory

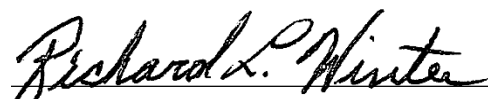

Written By: Joseph W. Jackson

Reviewed By: Richard L. Winter

Revision History		
Revision	Description	Date
01	Original Report Release	3 September 2024
02	Added DFS Spot Check Data In Section 2	12 September 2024
03	Revised Sections 2.2 and 2.3. Added Sections 2.4 and 2.5	16 September 2024
04	Removed Section 2.5	16 September 2024
05	Revised Section 2.4 and add Section 2.5	25 September 2024

Table of Contents

1	Client Information.....	5
1.1	Applicant.....	5
1.2	Manufacturer.....	5
2	Summary	6
2.1	Identification of EUT	6
2.2	Introduction.....	6
2.3	Description of EUT Differences and Justification	7
2.4	U7 Pro Spot Check Test Plan.....	8
2.5	Illustrations	9
3	Spot Check Test Data.....	10
3.1	Power and PSD	10
3.2	DFS	12
3.3	U7 Pro Spot Check – Radiated TX Spurious Emissions.....	17

1 Client Information

1.1 Applicant

Company	Ubiquiti Inc. 685 Third Avenue New York, NY 10017 U.S.A.
Contact Name	Alex Macon
Title	Compliance Manager

1.2 Manufacturer

Company	Ubiquiti Inc. 685 Third Avenue New York, NY 10017 U.S.A.
Contact Name	Alex Macon
Title	Compliance Manager

2 Summary

2.1 Identification of EUT

Brand Name	UBIQUITI
Model Number	U7 Pro
Serial Number	05B1B5
Dimensions (cm)	20.6 x 20.6 x 4.6

2.2 Introduction

The purpose of this document is to provide definition of the differences between models and evidence of their similarities. It will also identify the test data that is to be used between the models and identifies the data that will be new to the U7 Pro. This document is based on guidance provided in KDB 484596 DO1 Referencing Test Data. The applicant takes full responsibility for the fact that the test data referenced in this test report represents valid data for demonstrating compliance for the variants listed in this application. The following tables outline the identifying devices.

2.2.1 U7-Pro – (Original Equipment) Certification

	Equipment Class	Rule Part	Frequency Bands
U7-Pro	DTS	Part 15 C	2412 – 2462 MHz
	NII	Part 15 E	5180 – 5240 MHz
	NII	Part 15 E	5260 – 5320 MHz
	NII	Part 15 E	5500 – 5720 MHz
	NII	Part 15 E	5745 – 5825 MHz
	NII (6ID)	Part 15 E	5955 – 7115 MHz
	NII (6PP)	Part 15 E	5955 – 7115 MHz

2.2.2 U7 Pro – (New Original Equipment) Certification

	Equipment Class	Rule Part	Frequency Bands
U7 Pro	DTS	Part 15 C	2412 – 2462 MHz
	NII	Part 15 E	5180 – 5240 MHz
	NII	Part 15 E	5260 – 5320 MHz
	NII	Part 15 E	5500 – 5720 MHz
	NII	Part 15 E	5745 – 5825 MHz
	NII (6ID)	Part 15 E	5955 – 7115 MHz
	NII (6PP)	Part 15 E	5955 – 7115 MHz

2.3 Description of EUT Differences and Justification

U7-Pro (FCC ID: SWX-U7PRO / IC ID: 6545A-U7PRO) is identical to the U7 Pro (FCC ID: SWX-U7PROP / 6545A-U7PROP) in hardware and software other than the RF circuitry for the 2412 – 2462 MHz WiFi Band. In the 2412 – 2462 MHz WiFi Band the RF circuitry was changed from a one System on Chip (SOC) to a two chip set.

This change only affects the FCC Part 15 C of the FCC rules in the Equipment Class DTS. This band of the U7 Pro was completely retested and the testing results are found in test report “U7_Pro_FCC_15.247_WiFi_01”

No changes have been made in the hardware or software for the UNII-1 Band (5180–5240 MHz), UNII-2a Band (5260–5320 MHz), UNII-2c Band (5500–5720 MHz), (UNII-3 Band (5745–5825 MHz), UNII-5 Band (5955–6415 MHz), UNII-6 Band (6435–6515 MHz), UNII-7 Band (6535–6875 MHz) and UNII-8 Band (6895–7115 MHz). Since no changes have been made in these bands the applicant declares that the test date referenced in this test report represents valid data for demonstrating compliance for the variants listed in this application.

This spot check test report along with the original test report for the NII bands listed above are provided to show that since no changes have been made to the equipment subject to FCC Part 15 E of the FCC rules, the U7 Pro continues to comply with the FCC Rules and Regulations.

2.3.1 U7-Pro (Original Equipment) Certification

The U7-Pro was originally granted on 12/08/2023 for the frequency bands of 2412–2462 MHz, per CFR Part 15C, 15.247; 5180–5240 MHz, 5260–5320 MHz, 5500–5720 MHz, 5745–5825 MHz, per CFR Part 47 Part 15E, 15.407 and originally granted on 01/04/2024 for the frequency bands of 5955–7115 MHz, per CFR Part 47 Part 15E.

2.3.2 U7 Pro (New Equipment Certification) Proposal

The U7 Pro is requesting a grant for the frequency bands of 2412–2462 MHz, per CFR Part 15C, 15.247; 5180–5240 MHz; 5260–5320 MHz; 5500–5720 MHz; 5745–5825 MHz; and 5955–7115 MHz, per CFR Part 47 Part 15E.

The frequency bands of 5180–5240 MHz; 5260–5320 MHz; 5500–5720 MHz; 5745–5825 MHz; and 5955 – 7115 MHz have no hardware or software changes from the original certification of the U7-Pro (SWX-U7PRO / 6545A-U7PRO).

The frequency band of 2412–2462 MHz will be covered by a new separate test report due to the changes in this frequency band as described in Section 2.3 above and is the reason for this application.

2.4 U7 Pro Spot Check Test Plan

The spot-check plan listed in this section was formulated using good engineering judgement based on the knowledge of the device design by the Ubiquiti Inc. engineering team. The grantee of this device takes full responsible for the continued compliance to the FCC Rules. With this good engineering judgement, the confidence is high that the variant device will continue to be compliance with all the relevant FCC Rule parts.

2.4.1 Cross Reference Table

Reference Device	Variant Device	Key Differences
Model U7-Pro FCC ID: SWX-U7PRO	Model U7 Pro FCC ID: SWX-U7PROP	2412 – 2462 MHz WiFi Band the RF circuitry was changed from a one System on Chip (SOC) to a two chip set See Section 2.3 above

Rule Part	Test Item	Data Referencing	Comments
15.247	All testing	No	The 15.247 testing was completely retested. See test report U7_Pro_FCC_15.247_WiFi_01
U-NII Bands			
15.407	AC Mains Conducted	No	Note 1 Note 2
15.407	Bandwidth Requirement	No	Note 1 Note 2
15.407	Output Power	Yes	See Section 3.1
15.407	Spurious Emissions	Yes	See Section 3.3
15.407	Power Spectral Density	Yes	See Section 3.1
15.407 (U-NII-2)	DFS Requirement	Yes	See Section 3.2

Note 1: The following are the original test report references for UNII-1, UNII-2, UNII-3 and UNII-5 respectfully

- TR8594_U7-Pro_FCC_15.407_UNII-1_02
- TR8570_U7-Pro_15.407_UNII-2_02
- TR8575_U7-Pro_15.407_UNII-3_01
- TR8585_U7-Pro_FCC_15.407_UNII-5_04

Note 2: Combined Spot Check report combined with original report are:

- TR9367_U7_Pro_FCC_15.407_UNII-1_04
- TR9368_U7_Pro_FCC_15.407_UNII-2_04

- TR9369_U7_Pro_FCC_15.407_UNII-3_04
- TR9370_U7_Pro_FCC_15.407_UNII-5_04

2.4.2 Acceptance Criteria

The accepted criteria is listed under sections 2.4.3, 2.4.4 and 2.4.5.

2.4.3 U7 Pro Spot Check – Power / PSD

Per KDB 484596 DO1 a spot check was conducted for the bands that have no changes applied, 5180–5240 MHz; 5260–5320 MHz; 5500–5720 MHz; 5745–5825 MHz; and 5955–7115 MHz, to ensure the levels are still less than the original power reported during the certification process. Below is the spot check comparison with test report references. The test reports noted below will also be submitted to the TCB for reference.

The accepted criteria for the outcome of the spot check is continued compliance to the FCC Rules and reasonable close results to the original test data.

2.4.4 U7 Pro Spot Check – DFS

Per KDB 484596 D01 a spot check was conducted for the bands that have no changes applied, 5500-5720 MHz to ensure the level are still less than the original reported DFS during the original certification process. Below is the spot check comparison for the DFS portion.

The accepted criteria for the outcome of the spot check is continued compliance to the FCC Rules and reasonable close results to the original test data.

2.4.5 U7 Pro Spot Check – Radiated Emissions

Per KDB 484596 D01 a spot check was conducted for radiated emissions in the UNII-1, UNII-2 and UNII-5 bands that have no changes applied. Below is the spot check comparison for the Radiated Emissions portion.

The accepted criteria for the outcome of the spot check is continued compliance to the FCC Rules and reasonable close results to the original test data.

2.5 Illustrations

The illustration exhibit is being submitted separately due to the size restrictions. The exhibit is titled, “U7_Pro_Internal_Illustrations_Comparison.”

3 Spot Check Test Data

3.1 Power and PSD

5180–5240 MHz Band UNII-1 Spot Check

Mode	Frequency	UCL Results (10/3/2023)		UCL Results (8/29/2024)		Delta	
		RF Pwer	PSD	RF Pwer	PSD	RF Pwer	PSD
		W	dbm	W	dBm	W	dBm
HE20	5180	0.177	9.25	0.137	8.57	- 0.04	- 0.68
HE20	5210	0.415	12.86	0.334	12.44	- 0.08	- 0.42
HE20	5240	0.540	13.97	0.388	13.20	- 0.15	- 0.77
HE40	5190	0.113	4.37	0.088	4.05	- 0.03	- 0.32
HE40	5230	0.234	7.20	0.173	6.88	- 0.06	- 0.32
HE80	5210	0.134	1.75	0.099	1.39	- 0.04	- 0.36

5260–5320 MHz Band

UNII-2A Spot Check

Mode	Frequency	UCL Results (9/8/2023)		UCL Results (8/29/2024)		Delta	
		RF Pwer	PSD	RF Pwer	PSD	RF Pwer	PSD
		W	dbm	W	dBm	W	dBm
HE20	5260	0.230	10.11	0.185	9.66	- 0.05	- 0.45
HE20	5280	0.211	9.90	0.183	9.64	- 0.03	- 0.26
HE20	5320	0.208	9.72	0.195	9.85	- 0.01	0.13
HE40	5270	0.226	7.03	0.184	6.80	- 0.04	- 0.23
HE40	5310	0.220	6.82	0.199	6.98	- 0.02	0.16
HE80	5290	0.202	3.58	0.180	3.67	- 0.02	0.09
HE160	5250	0.225	1.18	0.180	0.64	- 0.05	- 0.54

5500–5720 MHz Band
UNII-2C Spot Check

Mode	Frequency	UCL Results (9/8/2023)		UCL Results (8/30/2024)		Delta	
		RF Pwer	PSD	RF Pwer	PSD	RF Pwer	PSD
		W	dbm	W	dBm	W	dBm
HE20	5500	0.242	10.55	0.217	10.70	- 0.02	0.15
HE20	5600	0.201	9.96	0.163	9.68	- 0.04	- 0.28
HE20	5720	0.250	10.75	0.173	10.15	- 0.08	- 0.60
HE40	5510	0.242	7.53	0.215	7.67	- 0.03	0.14
HE40	5590	0.207	6.90	0.164	6.60	- 0.04	- 0.30
HE40	5710	0.203	6.81	0.137	5.99	- 0.07	- 0.82
HE80	5530	0.237	4.41	0.205	6.08	- 0.03	1.67
HE80	5610	0.248	4.72	0.188	4.41	- 0.06	- 0.31
HE80	5690	0.240	4.74	0.155	3.62	- 0.09	- 1.12
HE160	5570	0.229	1.46	0.204	1.79	- 0.03	0.33

3.2 DFS

DFS Spot Check – 10 Trials at 80 MHz – All wave Forms

Original Summary Table from 10/18/2023

Summary			
Type	Detections	Trials	Detection Probability
Type 1	29	30	97%
Type 2	28	30	93%
Type 3	25	30	83%
Type 4	28	30	93%
Type 5	30	30	100%
Type 6	30	30	100%
Aggregate 1-4	110	120	92%

New Summary Table and Data from 9/11/2024

Summary			
Type	Detections	Trials	Detection Probability
Type 1	9	10	90%
Type 2	9	10	90%
Type 3	9	10	90%
Type 4	8	10	80%
Type 5	10	10	100%
Type 6	10	10	100%
Aggregate 1-4	35	40	88%

Trials

RADAR TYPE 1				Rohde & Schwarz K350 Pulse Sequencer DFS
Trial #	Number of Pulses per Burst	Pulse Width (µsec)	PRI (µs)	Detection (yes/no)
1	46	1	1152	y
2	58	1	918	y
3	19	1	2877	n

4	31	1	1726	y
5	18	1	2948	y
6	53	1	996	y
7	19	1	2829	y
8	87	1	611	y
9	31	1	1733	y
10	25	1	2148	y

9/10=90%

RADAR TYPE 2				Rohde & Schwarz K350 Pulse Sequencer DFS
Trial #	Number of Pulses per Burst	Pulse Width (µsec)	PRI (µs)	Detection (yes/no)
1	28	3.9	169	y
2	29	2.2	182	y
3	28	1.4	222	n
4	29	2	166	y
5	28	2.7	203	y
6	25	4	196	y
7	26	1.5	152	y
8	27	2.4	225	y
9	28	4.5	169	y
10	24	3.2	170	y

9/10=90%

RADAR TYPE 3				Rohde & Schwarz K350 Pulse Sequencer DFS
Trial #	Number of Pulses per Burst	Pulse Width (µsec)	PRI (µs)	Detection (yes/no)
1	18	9	387	y
2	17	9	433	y
3	18	6.1	453	y
4	17	6.7	368	n
5	17	9.5	241	y
6	16	6.5	337	y
7	17	9.2	288	y
8	18	8.1	474	y
9	16	6.2	284	y
10	18	9.6	476	y

9/10=90%

RADAR TYPE 4				Rohde & Schwarz K350 Pulse Sequencer DFS
Trial #	Number of Pulses per Burst	Pulse Width (µsec)	PRI (µs)	Detection (yes/no)
1	12	14.8	237	y
2	15	17	437	n
3	13	19.9	352	y
4	15	14	389	y
5	12	16	304	y
6	15	12.7	350	y
7	12	12.2	204	y
8	16	12.9	367	y
9	12	18.6	422	n
10	13	18	484	y

8/10=80%

TYPE 5		Rohde & Schwarz K350 Pulse Sequencer DFS		
Trial #	Detection (yes/no)	Chirp Width (MHz)	Subset	Fc
1	y	11	1	5570
2	y	19	1	5570
3	y	17	1	5570
4	y	13	1	5570
5	y	12	1	5570
6	y	17	1	5570
7	y	18	1	5570
8	y	9	1	5570
9	y	6	1	5570
10	y	13	1	5570

10/10=100%

TYPE 6 S		Rohde & Schwarz K350 Pulse Sequencer DFS
Trial #	Detection (yes/no)	
1	y	
2	y	
3	y	
4	y	
5	y	
6	y	
7	y	
8	y	
9	y	
10	y	

10/10=100%

5745–5825 MHz Band
UNII-3 Spot Check

Mode	Frequency	UCL Results (10/4/2023)		UCL Results (8/30/2024)		Delta	
		RF Pwer	PSD	RF Pwer	PSD	RF Pwer	PSD
		W	dbm	W	dBm	W	dBm
HE20	5745	0.697	12.12	0.465	11.29	- 0.23	- 0.83
HE20	5775	0.840	13.03	0.594	11.50	- 0.25	- 1.53
HE20	5825	0.621	11.33	0.490	10.71	- 0.13	- 0.62
HE40	5755	0.540	7.90	0.364	7.50	- 0.18	- 0.40
HE40	5775	0.628	8.70	0.401	7.19	- 0.23	- 1.51
HE40	5795	0.587	8.27	0.378	7.75	- 0.21	- 0.52
HE80	5775	0.244	1.81	0.163	1.36	- 0.08	- 0.45

5955–7115 MHz Band
UNII-5 Spot Check

Mode	Frequency	UCL Results (11/16/2023)		UCL Results (8/30/2024)		Delta	
		RF Pwer	PSD	RF Pwer	PSD	RF Pwer	PSD
		W (eirp)	dbm	W (eirp)	dBm	W (eirp)	dBm
EHT20	5955	0.062	-1.27	0.038	-1.82	- 0.02	- 0.55
EHT20	6195	0.071	-0.87	0.056	-1.22	- 0.01	- 0.35
EHT20	6415	0.074	-1.33	0.043	-2.81	- 0.03	- 1.48
EHT40	5965	0.139	-1.72	0.084	-1.72	- 0.06	0.00
EHT40	6205	0.143	-1.11	0.113	-1.33	- 0.03	- 0.22
EHT40	6405	0.153	-1.27	0.094	-2.22	- 0.06	- 0.95
EHT80	5985	0.262	-0.99	0.187	-1.39	- 0.08	- 0.40
EHT80	6225	0.277	-1.16	0.223	-1.19	- 0.05	- 0.03
EHT80	6385	0.282	-1.49	0.187	-2.31	- 0.09	- 0.82
EHT160	6025	0.467	-1.24	0.300	-1.59	- 0.17	- 0.35
EHT160	6185	0.492	-1.02	0.445	-0.95	- 0.05	0.07
EHT160	6325	0.578	-1.37	0.438	-1.37	- 0.14	0.00
EHT320	6265	0.869	-1.56	0.676	-2.13	- 0.19	- 0.57

3.3 U7 Pro Spot Check – Radiated TX Spurious Emissions

Per KDB 484596 DO1 a spot was conducted for the bands that have no changes applied (5180–5240 MHz; 5260–5320 MHz; 5500–5720 MHz; 5745–5825 MHz; and 5955–7115 MHz) to ensure the levels of spurious / harmonic emissions comply with CFR 47 Part 15.209 and 15.255 respectively as reported during the certification process. Below is the spot check comparison with test report references. The test report noted below will also be submitted to the TCB for reference.

UNII-1 Spurious Low Channel 1 – 17 GHz

Previous Data as recorded in Report #: U7-Pro_FCC_15.407_UNII-1_02

Peak

Frequency	Level (dB μ V/m)	Limit (dB μ V/m)	Margin (dB)	Azimuth (°)	Height (m)	Pol.	Correction (dB)
10.37 GHz	55.017	74	-18.98	136	1.643	Vertical	8.55
11.91 GHz	58.708	74	-15.29	87	1.638	Vertical	10.05
15.54 GHz	66.609	74	-7.39	124	2.645	Vertical	10.59
10.35 GHz	55.596	74	-18.40	162	2.645	Horizontal	8.39
15.53 GHz	59.965	74	-14.04	148	3.154	Horizontal	10.60

Avg

Frequency	Level (dB μ V/m)	Limit (dB μ V/m)	Margin (dB)	Azimuth (°)	Height (m)	Pol.	Correction (dB)
10.37 GHz	41.564	54	-12.44	136	1.643	Vertical	8.55
11.91 GHz	52.136	54	-1.86	87	1.638	Vertical	10.05
15.54 GHz	52.195	54	-1.81	124	2.645	Vertical	10.59
10.35 GHz	42.29	54	-11.71	162	2.645	Horizontal	8.39
15.53 GHz	45.337	54	-8.63	148	3.154	Horizontal	10.60

UNII-1 Spurious Low Channel

Data taken 8/19/2024

Peak

Frequency	Level (dB μ V/m)	Limit (dB μ V/m)	Margin (dB)	Azimuth (°)	Height (m)	Pol.	Correction (dB)
12.40 GHz	54.732	74	-19.27	89	2.329	Vertical	13.99
14.82 GHz	56.135	74	-17.87	13	4	Vertical	14.43
16.17 GHz	56.786	74	-17.21	70	1.834	Vertical	16.14
12.30 GHz	54.805	74	-19.20	23	1.834	Horizontal	14.42

Frequency	Level (dBμV/m)	Limit (dBμV/m)	Margin (dB)	Azimuth ($^{\circ}$)	Height (m)	Pol.	Correction (dB)
16.20 GHz	57.609	74	-16.39	318	1.643	Horizontal	16.74

Avg

Frequency	Level (dBμV/m)	Limit (dBμV/m)	Margin (dB)	Azimuth ($^{\circ}$)	Height (m)	Pol.	Correction (dB)
12.40 GHz	41.342	54	-12.66	89	2.329	Vertical	13.99
14.82 GHz	42.375	54	-11.63	13	4	Vertical	14.43
16.17 GHz	43.689	54	-10.31	70	1.834	Vertical	16.14
12.30 GHz	41.656	54	-12.34	23	1.834	Horizontal	14.42
16.20 GHz	44.344	54	-9.66	318	1.643	Horizontal	16.74

UNII-1 Spurious High Channel 1 – 17 GHz

Previous Data as recorded in Report #: U7-Pro_FCC_15.407_UNII-1_02

Peak

Frequency	Level (dBμV/m)	Limit (dBμV/m)	Margin (dB)	Azimuth (°)	Height (m)	Pol.	Correction (dB)
10.47 GHz	52.904	74	-21.10	5	4	Vertical	8.01
11.91 GHz	58.719	74	-15.28	88	1.643	Vertical	10.05
15.74 GHz	64.193	74	-9.81	147	1.638	Vertical	11.14
10.47 GHz	52.743	74	-21.26	147	1.834	Horizontal	7.97
15.72 GHz	62.14	74	-11.86	129	1.833	Horizontal	11.19

Avg

Frequency	Level (dBμV/m)	Limit (dBμV/m)	Margin (dB)	Azimuth (°)	Height (m)	Pol.	Correction (dB)
10.47 GHz	39.40	54	-14.60	5	4	Vertical	8.01
11.91 GHz	51.94	54	-2.06	88	1.643	Vertical	10.05
15.74 GHz	51.12	54	-2.88	147	1.638	Vertical	11.14
10.47 GHz	40.02	54	-13.98	147	1.834	Horizontal	7.97
15.72 GHz	48.94	54	-5.06	129	1.833	Horizontal	11.19

UNII-1 Spurious High Channel

Data taken 8/19/2024

Peak

Frequency	Level (dBμV/m)	Limit (dBμV/m)	Margin (dB)	Azimuth (°)	Height (m)	Pol.	Correction (dB)
12.95 GHz	54.344	74	-19.66	11	2.325	Vertical	14.65
14.70 GHz	56.687	74	-17.31	143	2.142	Vertical	15.65
16.21 GHz	57.226	74	-16.77	1	3.153	Vertical	16.70
13.01 GHz	55.226	74	-18.77	27	3.802	Horizontal	15.171
16.10 GHz	55.962	74	-18.04	210	3.802	Horizontal	14.875

Avg

Frequency	Level (dBμV/m)	Limit (dBμV/m)	Margin (dB)	Azimuth (°)	Height (m)	Pol.	Correction (dB)
12.95 GHz	41.121	54	-12.88	11	2.325	Vertical	14.65
14.70 GHz	43.596	54	10.40	143	2.142	Vertical	15.65
16.21 GHz	44.143	54	-9.86	1	3.153	Vertical	16.70

Frequency	Level (dBμV/m)	Limit (dBμV/m)	Margin (dB)	Azimuth ($^{\circ}$)	Height (m)	Pol.	Correction (dB)
13.01 GHz	41.503	54	-12.50	27	3.802	Horizontal	15.171
16.10 GHz	42.627	54	-11.37	210	3.802	Horizontal	14.875

UNII-5 Spurious Mid Channel 17 – 40 GHz

Previous Data as recorded in Report #: U7-Pro_FCC_15.407_UNII-5_01

Peak

Frequency	Level (dB μ V/m)	Limit (dB μ V/m)	Margin (dB)	Azimuth (°)	Pol.	Correction (dB)
17.01 GHz	50.362	74	-23.64	259	Horizontal	-0.01

Avg

Frequency	Level (dB μ V/m)	Limit (dB μ V/m)	Margin (dB)	Azimuth (°)	Pol.	Correction (dB)
17.01	37.261	54	-16.74	259	Horizontal	-0.01

UNII-5 Spurious Mid Channel

Data Taken 8/23/2024

Peak

Frequency	Level (dB μ V/m)	Limit (dB μ V/m)	Margin (dB)	Azimuth (°)	Pol.	Correction (dB)
33.46 GHz	55.159	74	-18.84	255	Vertical	4.54
34.91 GHz	57.259	74	-16.74	243	Vertical	6.22
33.80 GHz	55.817	74	-18.18	39	Horizontal	5.27
34.95 GHz	57.085	74	-16.92	156	Horizontal	6.33

Avg

Frequency	Level (dB μ V/m)	Limit (dB μ V/m)	Margin (dB)	Azimuth (°)	Pol.	Correction (dB)
33.46 GHz	42.024	54	-11.98	255	Vertical	4.54
34.91 GHz	43.668	54	-10.33	243	Vertical	6.22
33.80 GHz	42.543	54	-11.46	39	Horizontal	5.27
34.95 GHz	43.939	54	-10.06	156	Horizontal	6.33

-- End of Test Report --



427 West 12800 South
Draper, UT 84020

Test Report Certification

FCC ID	SWX-U7PRO
ISED ID	6545A-U7PRO
Equipment Under Test	U7-Pro
Test Report Serial Number	TR8570_02
Date of Test(s)	7, 8, 19 September; 17-19 October 2023
Report Issue Date	13 November 2023

Test Specification	Applicant
47 CFR FCC Part 15, Subpart E	Ubiquiti Inc. 685 Third Avenue New York, NY 10017 U.S.A.



NVLAP LAB CODE 600241-0

Certification of Engineering Report

This report has been prepared by Unified Compliance Laboratory (UCL) to document compliance of the device described below with the requirement of Federal Communication Commissions (FCC) Part 15, Subpart E. This report may be reproduced in full. Partial reproduction of this report may only be made with the written consent of the laboratory. The results in this report apply only to the sample tested.

Applicant	Ubiquiti Inc.
Manufacturer	Ubiquiti Inc.
Brand Name	UBIQUITI
Model Number	U7-Pro
FCC ID	SWX-U7PRO
ISED ID	6545A-U7PRO

On this 20th day of October 2023, I individually and for Unified Compliance Laboratory certify that the statements made in this engineering report are true, complete and correct to the best of my knowledge and are made in good faith.

Although NVLAP has accredited the Unified Compliance Laboratory testing facilities, this report must not be used to claim product certification, approval, or endorsement by NVLAP, NIST or any agency of the U.S. federal government.

Unified Compliance Laboratory



Written By: Tanner Langley

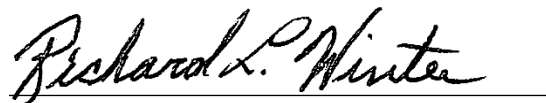

Reviewed By: Richard L. Winter

Revision History		
Revision	Description	Date
01	Original Report Release	20 October 2023
02	Added NSS -1 Data	13 November 2023

Table of Contents

1	Client Information.....	5
1.1	Applicant.....	5
1.2	Manufacturer.....	5
2	Equipment Under Test (EUT).....	6
2.1	Identification of EUT.....	6
2.2	Description of EUT.....	6
2.3	EUT and Support Equipment.....	7
2.4	Interface Ports on EUT.....	7
2.5	Operating Environment.....	7
2.6	Operating Modes.....	8
2.7	EUT Exercise Software.....	8
2.8	Block Diagram of Test Configuration.....	8
2.9	Modification Incorporated/Special Accessories on EUT.....	8
2.10	Deviation, Opinions Additional Information or Interpretations from Test Standard.....	8
3	Test Specification, Method and Procedures.....	9
3.1	Test Specification.....	9
3.2	Methods & Procedures.....	9
3.3	FCC Part 15, Subpart E.....	9
3.4	Results.....	9
3.5	Test Location.....	10
4	Test Equipment.....	11
4.1	Conducted Emissions at Mains Ports.....	11
4.2	Direct Connect at the Antenna Port Tests.....	11
4.3	Radiated Emissions.....	12
4.4	DFS Testing.....	13
4.5	Equipment Calibration.....	14
4.6	Measurement Uncertainty.....	14
5	Test Results.....	15
5.1	§15.203 Antenna Requirements.....	15
5.2	Conducted Emissions at Mains Ports Data.....	15
5.3	§15.403(i) 26 dB Emissions Bandwidth.....	16
5.4	§15.407(a)(2) Maximum Average Output Power.....	17
5.5	§15.407(b) Spurious Emissions.....	19
5.6	§15.407(a) Maximum Power Spectral Density.....	24
5.7	DFS Requirement.....	27

1 Client Information

1.1 Applicant

Company	Ubiquiti Inc. 685 Third Avenue New York, NY 10017 U.S.A.
Contact Name	Alex Macon
Title	Compliance

1.2 Manufacturer

Company	Ubiquiti Inc. 685 Third Avenue New York, NY 10017 U.S.A.
Contact Name	Alex Macon
Title	Compliance

2 Equipment Under Test (EUT)

2.1 Identification of EUT

Brand Name	UBIQUITI
Model Number	U7-Pro
Serial Number	9AZ 003
Dimensions (cm)	20.6 x 20.6 x 4.6

2.2 Description of EUT

The U7-Pro is WiFi 7 access point that represents the next generation of competitively priced, prosumer wireless technology for home and enterprise users. The U7-Pro provides high aggregate throughput speeds. The U7-Pro transmit in the 2.4 GHz, 5 GHz and 6 GHz frequency bands and uses integrated antennas. The U7-Pro is powered from an 802.3at power adapter.

Band	Modulation Bandwidth	Frequency (MHz)
UNII-2A	20 MHz	5260, 5265, 5270, 5275, 5280, 5285, 5290, 5295, 5300, 5305, 5310, 5315, 5320
	40 MHz	5270, 5275, 5280, 5285, 5290, 5295, 5300, 5305, 5310
	80 MHz	5290
	160 MHz	5250
UNII-2C	20 MHz	5500, 5505, 5510, 5515, 5520, 5525, 5530, 5535, 5540, 5545, 5550, 5555, 5560, 5565, 5570, 5575, 5580, 5585, 5590, 5595, 5600*, 5605*, 5610*, 5615*, 5620*, 5625*, 5630*, 5635*, 5640*, 5645*, 5650, 5655, 5660, 5665, 5670, 5675, 5680, 5685, 5690, 5695, 5700, 5705, 5710, 5715, 5720
	40 MHz	5510, 5515, 5520, 5525, 5530, 5535, 5540, 5545, 5550, 5555, 5560, 5565, 5570, 5575, 5580, 5585, 5590, 5595, 5600*, 5605*, 5610*, 5615*, 5620*, 5625*, 5630*, 5635*, 5640*, 5645*, 5650, 5655, 5660, 5665, 5670, 5675, 5680, 5685, 5690, 5695, 5700, 5705, 5710
	80 MHz	5530, 5535, 5540, 5545, 5550, 5555, 5560, 5565, 5570, 5575, 5580, 5585, 5590, 5595, 5600*, 5605*, 5610*, 5615*, 5620*, 5625*, 5630*, 5635*, 5640*, 5645*, 5650, 5655, 5660, 5665, 5670, 5675, 5680, 5685, 5690
	160 MHz	5570
* Frequency not applicable in Canada		

Table 1: UNII-2A and UNII-2C Channel Settings

This report covers the circuitry of the device subject to FCC Part 15, Subpart E. The circuitry of the device subject to FCC Part 15 Subpart B was found to be compliant and is covered under a separate Unified Compliance Laboratory test report.

2.3 EUT and Support Equipment

The EUT and support equipment used during the test are listed below.

Brand Name Model Number Serial Number	Description	Name of Interface Ports / Interface Cables
BN: UBIQUITI MN: U7-Pro SN: 9AZ 003	WiFi Access Point	See Section 2.4
BN: UBIQUITI MN: U-POE-at SN: N/A	PoE Power Adapter	Unshielded Cat 5e cable/1 meters
BN: Dell MN: XPS 13 SN: N/A	Laptop Personal Computer	Unshielded Cat 5e cable/1 meters

Notes: (1) EUT

(2) Interface port connected to EUT (See Section 2.4)

The support equipment listed above was not modified in order to achieve compliance with this standard.

2.4 Interface Ports on EUT

Name of Ports	No. of Ports Fitted to EUT	Cable Description/Length
AC Mains	1	3 conductor power cord/80 cm
POE (POE Injector)	1	Unshielded Cat 5e cable/8 meters
LAN (POE Injector)	1	Unshielded Cat 5e cable/1 meters

2.5 Operating Environment

Power Supply	120 Volts AC Mains to 48 Volts PoE
AC Mains Frequency	60 Hz
Temperature	22.2 – 27.6 °C
Humidity	26.72 – 37.95 %
Barometric Pressure	1020 mBar

2.6 Operating Modes

The U7-Pro was tested using test software in order to enable to constant transmission. The measurements within this report are corrected to reference a 100% duty cycle. All emission modes of 802.11 ax were investigated. All measurements are reported with the worst-case mode (802.11ax) unless otherwise stated.

2.7 EUT Exercise Software

EUT firmware version 1.0 was used to operate the transmitter using a constant transmit mode.

2.8 Block Diagram of Test Configuration

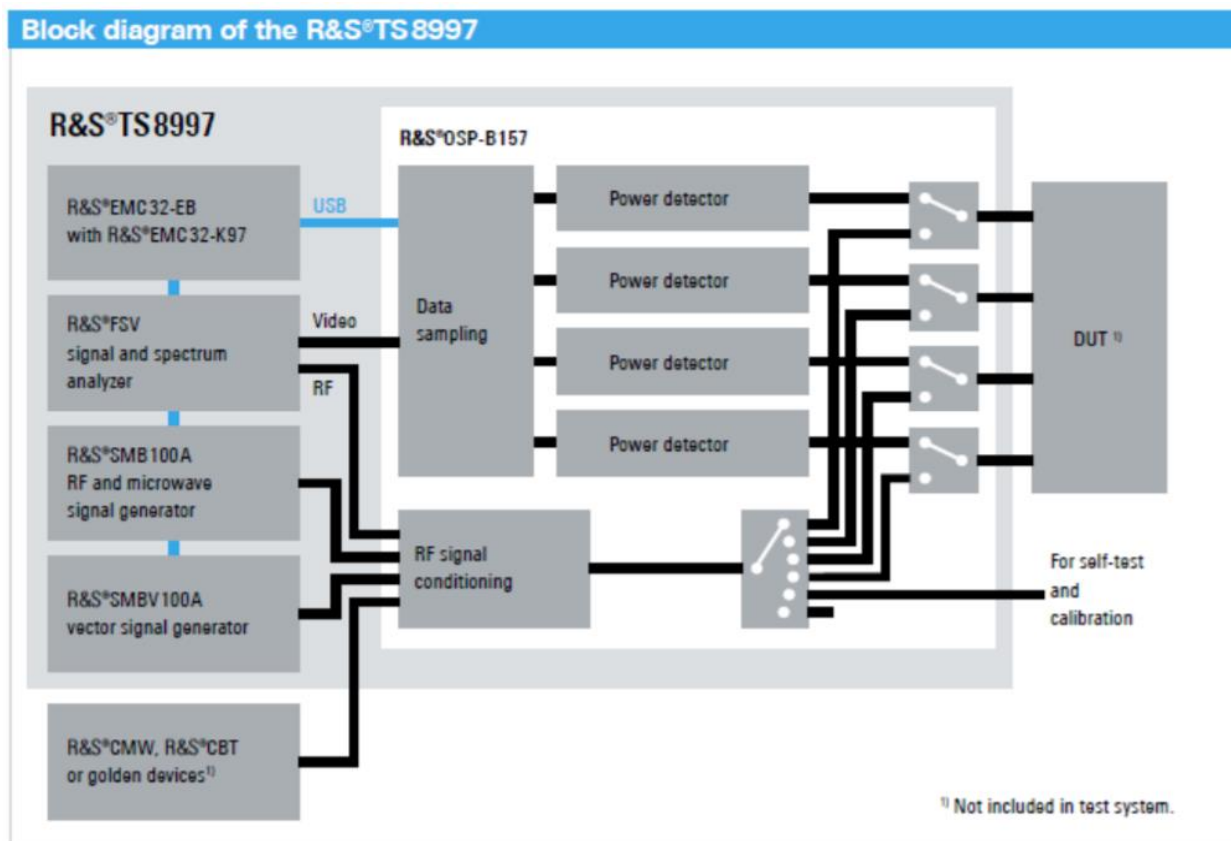

Diagram 1: Test Configuration Block Diagram

2.9 Modification Incorporated/Special Accessories on EUT

There were no modifications made to the EUT during testing to comply with the specification.

2.10 Deviation, Opinions Additional Information or Interpretations from Test Standard

There were no deviations, opinions, additional information or interpretations from the test specification.

3 Test Specification, Method and Procedures

3.1 Test Specification

Title	47 CFR FCC Part 15, Subpart E, Section 15.407 Limits and methods of measurement of radio interference characteristics of Unlicensed National Information Infrastructure Devices
Purpose of Test	The tests were performed to demonstrate initial compliance

3.2 Methods & Procedures

3.2.1 47 CFR FCC Part 15 Section 15.407

See test standard for details.

3.3 FCC Part 15, Subpart E

3.3.1 Summary of Tests

FCC Section	ISED Section	Environmental Phenomena	Frequency Range (MHZ)	Result
15.407(a)	N/A	Antenna requirements	Structural Requirement	Compliant
15.407(b)	RSS-Gen	Conducted Disturbance at Mains Port	0.15 to 30	Compliant
15.407(a)	RSS-247 §6.2.2, §6.2.3	Bandwidth Requirement	5260 to 5570	Compliant
15.407(a)	RSS-247 §6.2.2, §6.2.3	Peak Output Power	5260 to 5570	Compliant
15.407(b)	RSS-247 §6.2.2, §6.2.3	Antenna Conducted Spurious Emissions	0.009 to 40000	Compliant
15.407(b)	RSS-247 §6.2.2, §6.2.3	Radiated Spurious Emissions	0.009 to 40000	Compliant
15.407(a)	RSS-247 §6.2.2, §6.2.3	Peak Power Spectral Density	5260 to 5570	Compliant
15.407(h)	RSS-247 §6.3	DFS Requirements	5260 to 5570	Compliant

The testing was performed according to the procedures in ANSI C63.10-2013, KDB 558074 and 47 CFR Part 15. Where applicable, KDB 662911 was followed to sum required measurements.

3.4 Results

In the configuration tested, the EUT complied with the requirements of the specification.

3.5 Test Location

Testing was performed at the Unified Compliance Laboratory 3-Meter and 10-Meter chambers located at 427 West 12800 South, Draper, UT 84020. Unified Compliance Laboratory is accredited by National Voluntary Laboratory Accreditation Program (NVLAP); NVLAP Code 600241-0 which is effective until 30 June 2024. This site has also been registered with Innovations, Science and Economic Development (ISED) department as was accepted under Appendix B, Phase 1 procedures of the APEC Tel MRA for Canadian recognition. ISED No.: 25346, effective until 30 June 2024.

Unified Compliance Laboratory has been assigned Designation Number US5037 by the FCC and Conformity Assessment Number US0223 by ISED.

4 Test Equipment

4.1 Conducted Emissions at Mains Ports

Type of Equipment	Manufacturer	Model Number	Asset Number	Date of Last Calibration	Due Date of Calibration
EMI Receiver	AFJ	FFT3010	UCL-6754	2/22/2023	2/22/2024
LISN	AFJ	LS16C/10	UCL-6749	12/6/2021	12/6/2023
ISN	Teseq	ISN T800	UCL-2974	6/27/2022	6/27/2024
LISN	Com-Power	LIN-120C	UCL-2612	1/24/2023	1/24/2024
AC Power Source	Laplace Instruments	AC1000A	UCL-2857	N/A	N/A
Test Software	UCL	Revision 1	UCL-3107	N/A	N/A

Table 2: List of equipment used for Conducted Emissions Testing at Mains Port

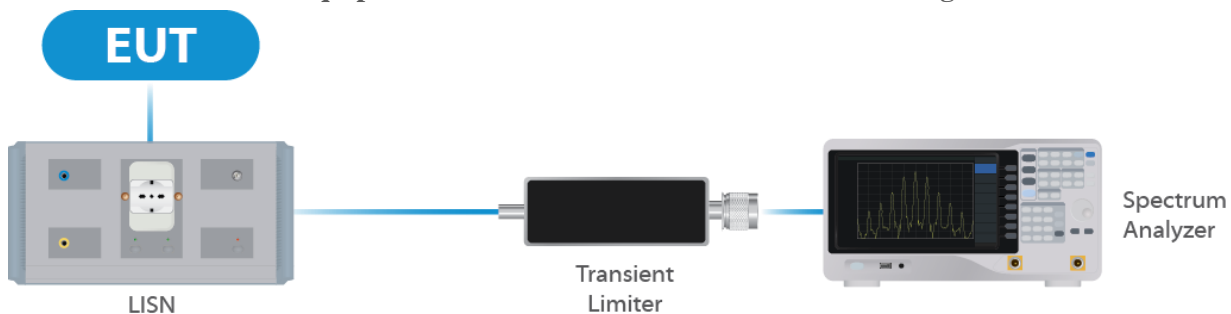

Figure 1: Conducted Emissions Test

4.2 Direct Connect at the Antenna Port Tests

Type of Equipment	Manufacturer	Model Number	Asset Number	Date of Last Calibration	Due Date of Calibration
Spectrum Analyzer	R&S	FSV40	UCL-2861	11/7/2022	11/7/2023
Signal Generator	R&S	SMB100A	UCL-2864	N/A	N/A
Vector Signal Generator	R&S	SMBV100A	UCL-2873	N/A	N/A
Switch Extension	R&S	OSP-B157WX	UCL-2867	2/22/2023	2/22/2024
Switch Extension	R&S	OSP-150W	UCL-2870	2/22/2023	2/22/2024

Table 3: List of equipment used for Direct Connect at the Antenna Port

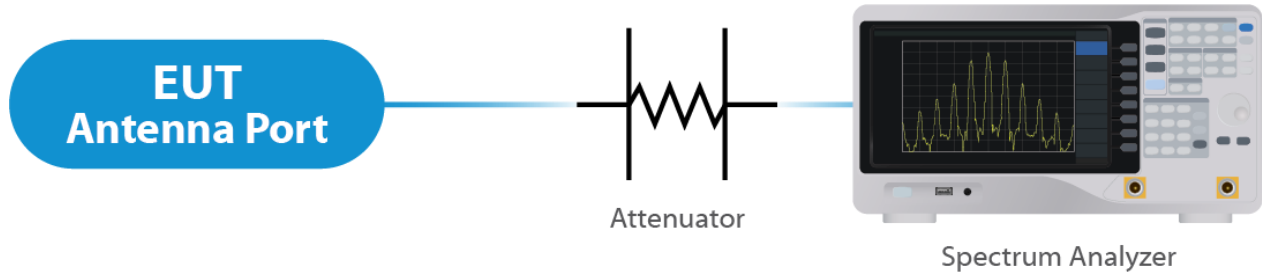

Figure 2: Direct Connect at the Antenna Port Test

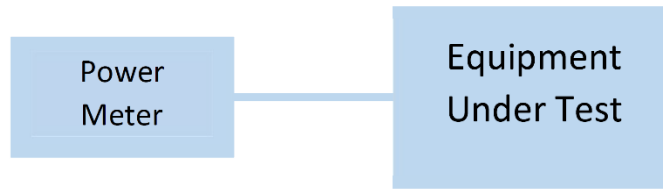

Figure 3: Output Power Measurement

4.3 Radiated Emissions

Type of Equipment	Manufacturer	Model Number	Asset Number	Date of Last Calibration	Due Date of Calibration
EMI Receiver	Keysight	N9038A	UCL-2778	1/27/2023	1/27/2024
Pre-Amplifier 9 kHz – 1 GHz	Sonoma Instruments	310N	UCL-2889	10/7/2021	11/7/2023
Broadband Antenna	Scwarzbeck	VULB 9163	UCL-3062	2/22/2023	2/22/2025
Broadband Antenna	Scwarzbeck	VULB 9163	UCL-3071	1/11/2023	1/11/2025
Double Ridge Horn Antenna	Scwarzbeck	BBHA 9120D	UCL-3065	9/22/2022	9/22/2024
Log Periodic	Scwarzbeck	STLP 9129	UCL-3068	1/27/2023	1/27/2025
15 - 40 GHz Horn Antenna	Scwarzbeck	BBHA 9170	UCL-2487	6/09/2022	6/09/2024
1 – 18 GHz Amplifier	Com-Power	PAM 118A	UCL-3833	12/9/2022	12/9/2023
Test Software	UCL	Revision 1	UCL-3108	N/A	N/A

Table 4: List of equipment used for Radiated Emissions

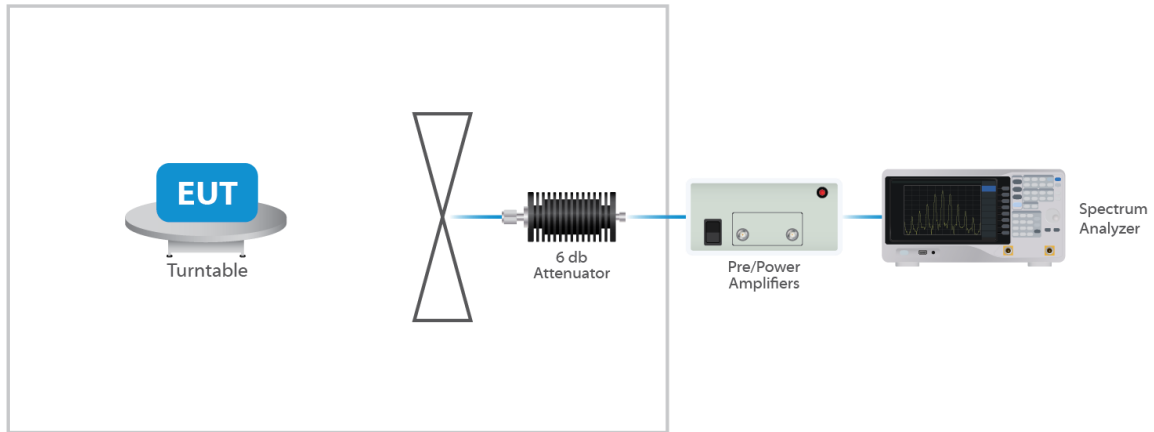

Figure 4: Radiated Emissions Test

4.4 DFS Testing

Type of Equipment	Manufacturer	Model Number	Asset Number	Date of Last Calibration	Due Date of Calibration
Vector Signal Generator	R&S	SMBV100A	UCL-2873	N/A	N/A
Spectrum Analyzer	Keysight	N9010B	UCL-7069	4/25/2023	4/26/2024

4.4.1 Master Test Set Up

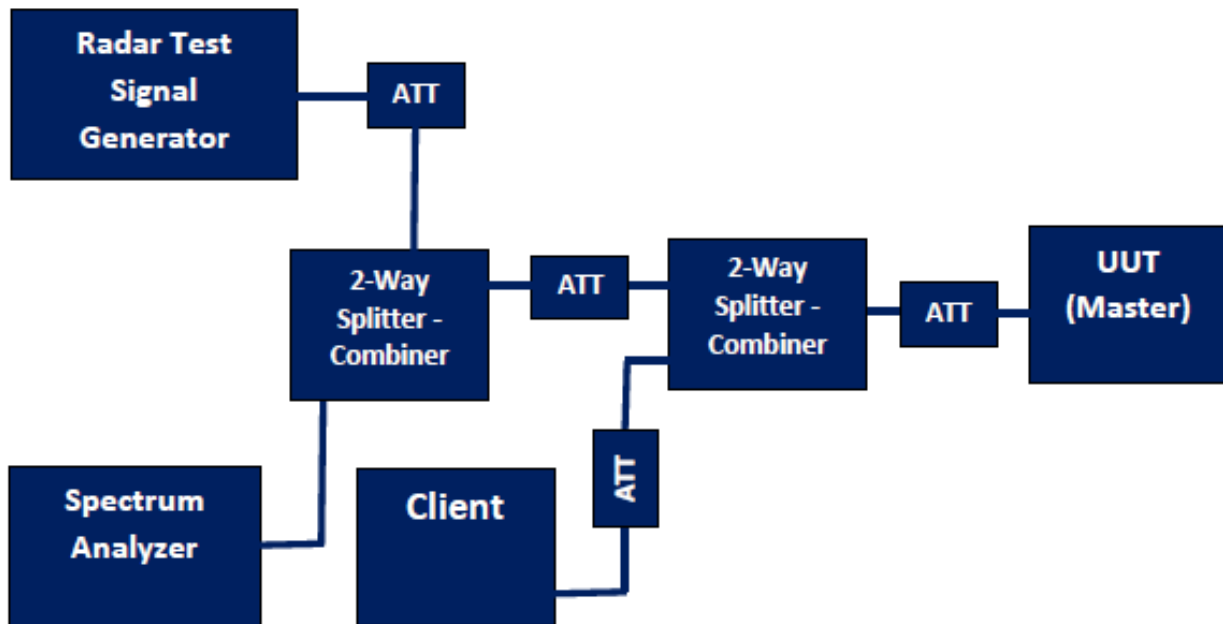

Figure 5: DFS Test Set Up - Master

4.5 Equipment Calibration

All applicable equipment is calibrated using either an independent calibration laboratory or Unified Compliance Laboratory personnel at intervals defined in ANSI C63.4:2014 following outlined calibration procedures. All measurement instrumentation is traceable to the National Institute of Standards and Technology (NIST). Supporting documentation relative to traceability is on file and is available for examination upon request.

4.6 Measurement Uncertainty

Test	Uncertainty (\pm dB)	Confidence (%)
Conducted Emissions	1.44	95
Radiated Emissions (9 kHz to 30 MHz)	2.50	95
Radiated Emissions (30 MHz to 1 GHz)	4.38	95
Radiated Emissions (1 GHz to 18 GHz)	4.37	95
Radiated Emissions (18 GHz to 40 GHz)	3.93	95
Direct Connect Tests	K Factor	Value
Emissions Bandwidth	2	2.0%
Output Power	2	1.0 dB
Peak Power Spectral Density	2	1.3 dB
Band Edge	2	0.8 dB
Transmitter Spurious Emissions	2	1.8 dB

5 Test Results

5.1 §15.203 Antenna Requirements

The EUT uses a integrated antenna. Per the manufacturer, the Maximum gain of the antenna is 6 dBi. This is an 802.11 device and utilizes CDD as described in KDB 662911 D01. The antenna is not user replaceable.

For power measurements on IEEE 802.11 devices, Array Gain = 0 dB for NANT ≤ 4;

For PSD measurements when Nss=1: Array Gain = 10 log(Nant/Nss) dB = 3.01dB

Results

The EUT complied with the specification

5.2 Conducted Emissions at Mains Ports Data

5.2.1 Line

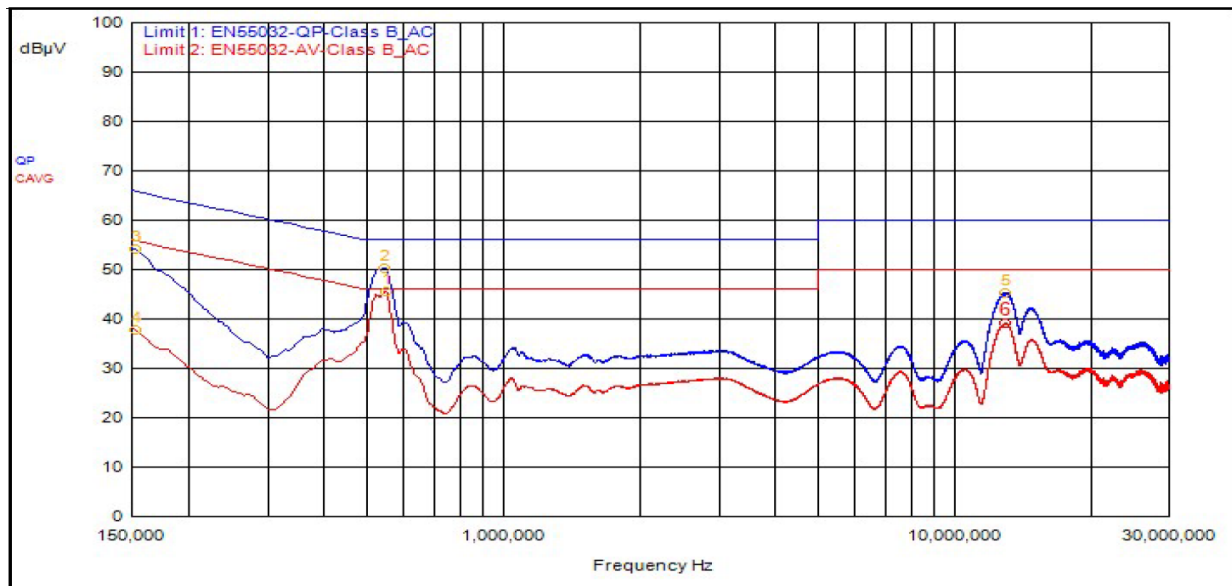

ID	Frequency	Probe	Cable	Atten.	Detector	Meter Read	Meas Level	Limit 1	Limit 1 Dist.	Limit 2	Limit 2 Dist.	P/F
MU	MHz	dB	dB	dB	Type	dBµV	dBµV	dBµV	dB	dBµV	dB	P/F
2	546,000kHz	12.23	0.00		QPeak	38.16	50.39	56.00	-5.61			
3	153,000kHz	12.26	0.00		QPeak	41.82	54.08	65.84	-11.76			
5	12.996	12.27	0.00		QPeak	33.02	45.29	60.00	-14.71			
1	549,000kHz	12.23	0.00		C_AVG	33.22	45.45			46.00	-0.55	
4	153,000kHz	12.26	0.00		C_AVG	25.61	37.87			55.84	-17.96	
6	12.981	12.27	0.00		C_AVG	26.77	39.04			50.00	-10.96	

5.2.2 Neutral

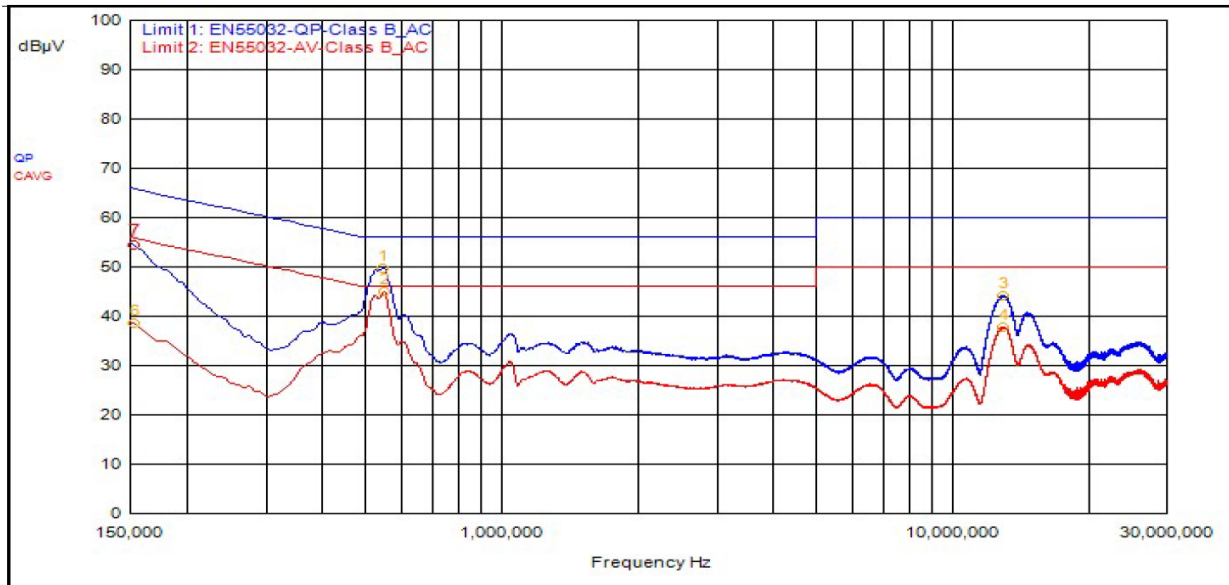

ID	Frequency	Probe	Cable	Atten.	Detector	Meter Read	Meas Level	Limit 1	Limit 1 Dist.	Limit 2	Limit 2 Dist.	P/F
MU	MHz	dB	dB	dB	Type	dBµV	dBµV	dBµV	dB	dBµV	dB	P/F
1	546,000kHz	12.18	0.00		QPeak	37.58	49.76	56.00	-6.24			
5	150,000kHz	12.21	0.00		QPeak	42.89	55.10	66.00	-10.90			
7	153,000kHz	12.21	0.00		QPeak	42.12	54.33	65.84	-11.50			
3	12.993	12.29	0.00		QPeak	31.97	44.26	60.00	-15.74			
2	549,000kHz	12.18	0.00		C_AVG	32.76	44.94			46.00	-1.06	
4	12.966	12.29	0.00		C_AVG	25.48	37.77			50.00	-12.23	
6	153,000kHz	12.21	0.00		C_AVG	26.39	38.60			55.84	-17.24	

Result

The EUT complied with the specification limit.

5.3 §15.403(i) 26 dB Emissions Bandwidth

All chains were measured under the guidance of KDB 789033 Section II.C. and KDB 66291 D01. Please see associated annex for details on instrument settings.

5.3.1 UNII-2A

Bandwidth	Frequency (MHz)	99% Bandwidth (MHz)	Emissions 26 dB Bandwidth (MHz)
20	5260	19.1	22.5

20	5280	19.1	22.9
20	5320	19.1	23.0
40	5270	38.25	43.35
40	5310	38.25	43.8
80	5290	78.0	90.0
160	5250	158.0	172.0

5.3.2 UNII-2C

Bandwidth	Frequency (MHz)	99% Bandwidth (MHz)	Emissions 26 dB Bandwidth (MHz)
20	5500	19.1	23.2
20	5600	19.2	22.9
20	5720	19.2	22.8
40	5510	38.25	43.05
40	5590	38.25	43.2
40	5710	38.25	43.95
80	5530	77.5	87.5
80	5610	78.5	89.5
80	5690	77.5	88.5
160	5570	157	173.0

Result

The 26 dB bandwidths are reported for information purposes. Please see Annex for all bandwidth measurements.

5.4 §15.407(a)(2) Maximum Average Output Power

All chains were measured and summed under the guidance of KDB 789033 Section II. E.2. and KDB 66291 D01. Please see associated annex for details on instrument settings.

The maximum average RF conducted output power measured for this device was 23.99 dBm or 250 mW. The limit is 24 dBm or 250 mW when using antennas with 6 dBi or less gain. The antenna has a maximum gain of 6 dBi.

5.4.1 UNII-2A

Modulation (BW)	Frequency (MHz)	Data Rate	TP Setting	Conducted Output Power*	Measured PSD
OFDM 20	5260	Mcs0	21	23.48	10.84
OFDM 20	5280	Mcs0	21	23.16	10.60
OFDM 20	5320	Mcs0	21	23.06	10.46
HE20	5260	Mcs0	21	23.59	10.11
HE20	5280	Mcs0	21	23.25	9.90
HE20	5320	Mcs0	21	23.18	9.72
HE40	5270	Mcs0	21	23.54	7.03
HE40	5310	Mcs0	21	23.42	6.82
HE80	5290	Mcs0	21	23.06	3.58
HE160	5250	Mcs0	21	23.53	1.18

5.4.2 UNII-2C

Modulation (BW)	Frequency (MHz)	Data Rate	TP Setting	Conducted Output Power*	Measured PSD
OFDM 20	5500	Mcs0	22	23.71	10.96
OFDM 20	5600	Mcs0	21	22.85	10.34
OFDM 20	5720	Mcs0	21	22.82	10.09
HE20	5500	Mcs0	22	23.84	10.55
HE20	5600	Mcs0	21	23.03	9.96
HE20	5720	Mcs0	22	23.99	10.75
HE40	5510	Mcs0	22	23.83	7.53
HE40	5590	Mcs0	21	23.15	6.90
HE40	5710	Mcs0	21	23.07	6.81
HE80	5530	Mcs0	22	23.74	4.41
HE80	5610	Mcs0	22	23.94	4.72
HE80	5690	Mcs0	22	23.81	4.74
HE160	5570	Mcs0	22	23.59	1.46

Result

In the configuration tested, the maximum average RF output power was less than 1 watt; therefore, the EUT complied with the requirements of the specification.

5.5 §15.407(b) Spurious Emissions

5.5.1 Conducted Spurious Emissions

The frequency range from the lowest frequency generated or used in the device to the tenth harmonic of the highest fundamental frequency was investigated to measure any antenna-conducted emissions. The graphs show the measurement data from spurious emissions noted across the frequency range when transmitting at the lowest frequency, middle frequency and upper frequency. Shown below are plots with the EUT turned to the upper and lower channels with the antenna gain of 6 dBi accounted for. These demonstrate compliance with the provisions of this section at the band edges.

The emissions must be below -27 dBm EIRP.

Result

Conducted spurious emissions were below -27 dBm; therefore, the EUT complies with the specification. See Annex for results.

5.5.2 Radiated Spurious Emissions in the Restricted Bands of § 15.205

The frequency range from the lowest frequency generated or used in the device to the tenth harmonic of the highest fundamental emissions was investigated to measure any radiated emissions in the restricted bands. For frequencies above 18.0 GHz. The emissions in the restricted bands must meet the limits specified in § 15.209. Conducted measurement results are included in the Annex. Radiated data with the EUT transmitting into a load is included below. All emissions between the required frequencies were investigated, the following plots represent the worst case. The “fail” is the transmitted signal exceeding the spurious limit.

Correction Factor = Antenna Factor + Cable Loss - Pre-Amplifier Gain, and is added to the Receiver reading.

5.5.3 UNII-2A

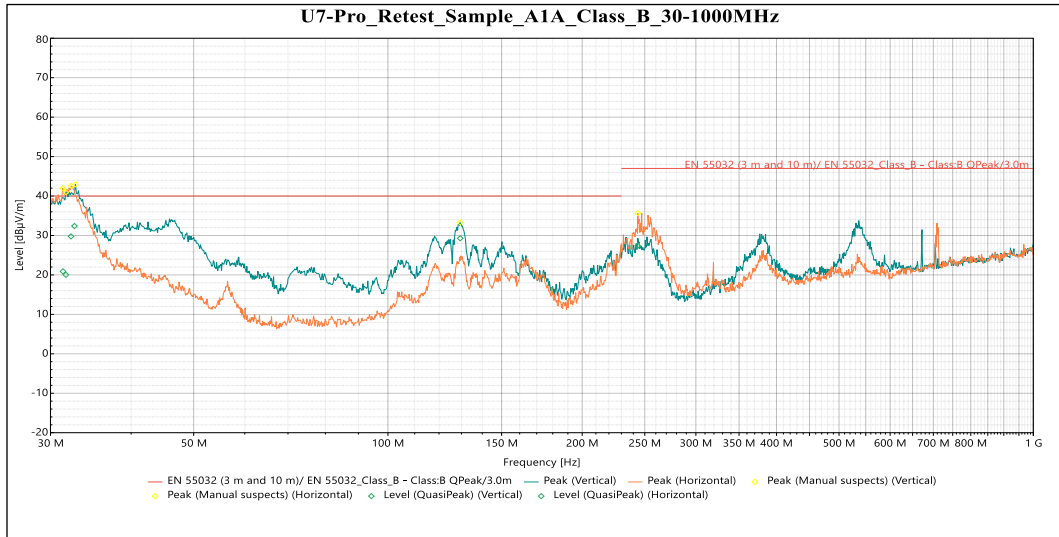

Frequency	SR #	Level (dBµV/m)	Limit (dBµV/m)	Margin	Azimuth (°)	Height	Pol.	Meas. Time	RBW (Hz)	Meas.Time (s)	Correction (dB)
31.692 MHz	1	20.029	40	-19.971	69	2.759	Vertical	15	120 k	0.001	-8.569
32.681 MHz	1	32.403	40	-7.597	199	1	Vertical	15	120 k	0.001	-9.148
129.41 MHz	1	29.287	40	-10.713	341	1.138	Vertical	15	120 k	0.001	-14.232
31.369 MHz	2	20.912	40	-19.088	251	1.143	Horizontal	15	120 k	0.001	-8.51
32.273 MHz	2	29.759	40	-10.241	50	3.298	Horizontal	15	120 k	0.001	-8.831
243.82 MHz	2	27.376	47	-19.624	278	1.52	Horizontal	15	120 k	0.001	-15.915

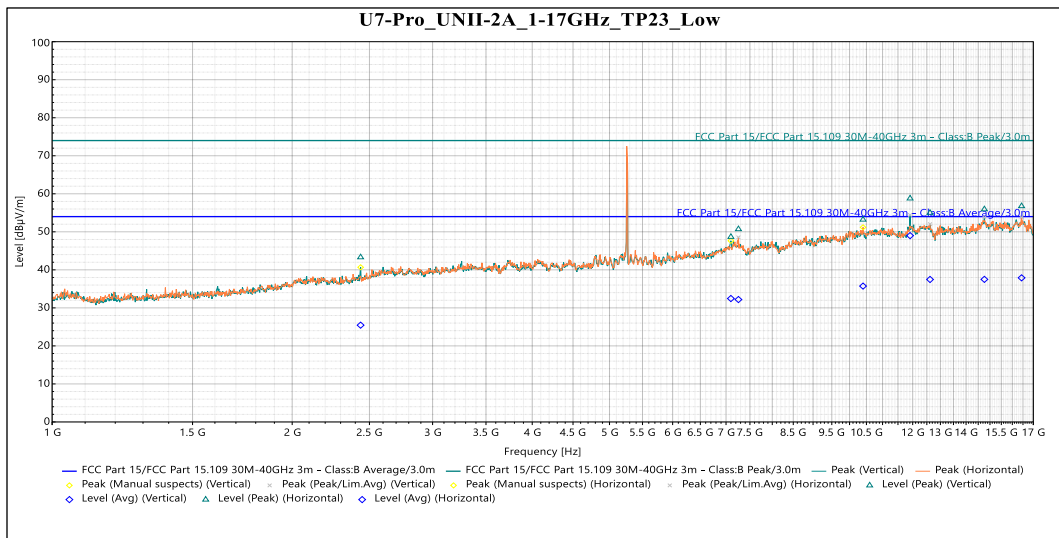
Graph 1: Radiated Emissions within 30MHz - 1GHz

Final source: Peak

Frequency	SR #	Level (dBµV/m)	Limit (dBµV/m)	Margin (dB)	Azimuth (°)	Height (m)	Pol.	Meas. Time (s)	RBW (Hz)	Meas.Time (s)	Correction (dB)
2.4369 GHz	1	43.311	74	-30.689	352	1.872	Vertical	15	1 M	0	-3.484
7.0991 GHz	1	48.669	74	-25.331	120	3.083	Vertical	15	1 M	0	10.546
11.91 GHz	1	58.782	74	-15.218	359	1.692	Vertical	15	1 M	0	16.544
14.76 GHz	1	55.932	74	-18.068	109	2.923	Vertical	15	1 M	0	16.995
7.2554 GHz	2	50.711	74	-23.289	333	1.521	Horizontal	5	1 M	0	11.219

Frequency	SR #	Level (dB μ V/m)	Limit (dB μ V/m)	Margin (dB)	Azimuth (°)	Height (m)	Pol.	Meas. Time (s)	RBW (Hz)	Meas.Time (s)	Correction (dB)
10.397 GHz	2	53.211	74	-20.789	345	2.721	Horizontal	5	1 M	0	14.909
12.616 GHz	2	54.989	74	-19.011	247	2.721	Horizontal	5	1 M	0	16.51
16.434 GHz	2	56.763	74	-17.237	233	3.264	Horizontal	5	1 M	0	18.22

Final source: Avg

Frequency	SR #	Level (dB μ V/m)	Limit (dB μ V/m)	Margin (dB)	Azimuth (°)	Height (m)	Pol.	Meas. Time (s)	RBW (Hz)	Meas.Time (s)	Correction (dB)
2.4369 GHz	1	25.446	54	-28.554	352	1.872	Vertical	15	1 M	0	-3.484
7.0991 GHz	1	32.461	54	-21.539	120	3.083	Vertical	15	1 M	0	10.546
11.91 GHz	1	49	54	-5	359	1.692	Vertical	15	1 M	0	16.544
14.76 GHz	1	37.5	54	-16.5	109	2.923	Vertical	15	1 M	0	16.995
7.2554 GHz	2	32.189	54	-21.811	333	1.521	Horizontal	5	1 M	0	11.219
10.397 GHz	2	35.735	54	-18.265	345	2.721	Horizontal	5	1 M	0	14.909
12.616 GHz	2	37.468	54	-16.532	247	2.721	Horizontal	5	1 M	0	16.51
16.434 GHz	2	37.904	54	-16.096	233	3.264	Horizontal	5	1 M	0	18.22

Graph 2: 1 GHz – 17 GHz Middle Channel (Worst Case)

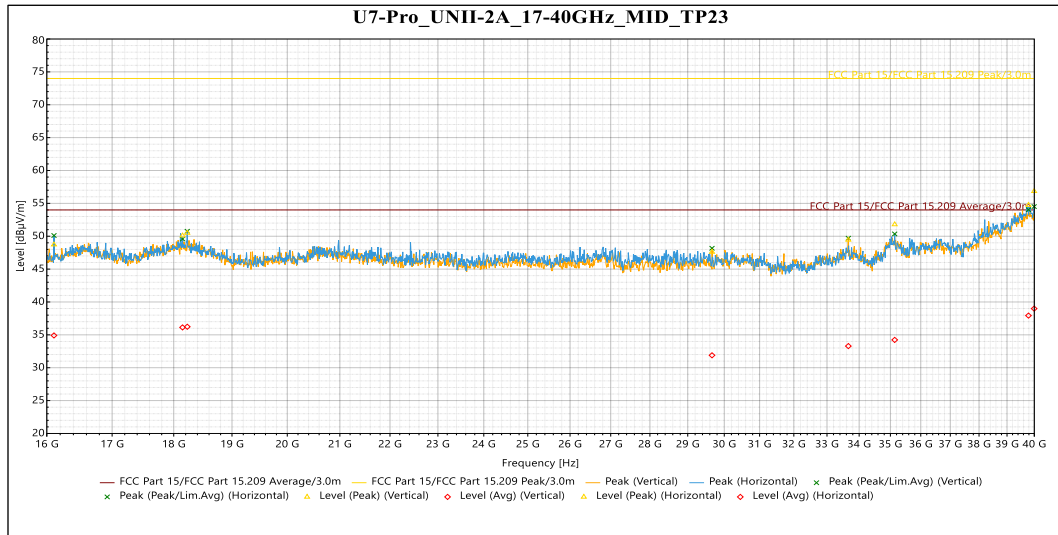

Final source: Peak

Frequency	SR #	Level (dB μ V/m)	Limit (dB μ V/m)	Margin (dB)	Azimuth (°)	Pol.	Meas. Time (s)	RBW (Hz)	Meas.Time (s)	Correction (dB)
18.148 GHz	1	50.087	74	-23.913	75	Vertical	5	1 M	0	-0.513
29.661 GHz	1	47.61	74	-26.39	82	Vertical	5	1 M	0	-1.215
33.661 GHz	1	49.454	74	-24.546	359	Vertical	5	1 M	0	0.443
39.784 GHz	1	54.74	74	-19.26	121	Vertical	5	1 M	0	5.287
16.107 GHz	2	48.722	74	-25.278	133	Horizontal	5	1 M	0	0.661
18.228 GHz	2	50.502	74	-23.498	287	Horizontal	5	1 M	0	-0.511
35.14 GHz	2	51.786	74	-22.214	311	Horizontal	5	1 M	0	2.575
39.994 GHz	2	56.846	74	-17.154	318	Horizontal	5	1 M	0	5.125

Final source: Avg

Frequency	SR #	Level (dB μ V/m)	Limit (dB μ V/m)	Margin (dB)	Azimuth (°)	Pol.	Meas. Time (s)	RBW (Hz)	Meas.Time (s)	Correction (dB)
18.148 GHz	1	36.135	54	-17.865	75	Vertical	5	1 M	0	-0.513
29.661 GHz	1	31.886	54	-22.114	82	Vertical	5	1 M	0	-1.215
33.661 GHz	1	33.288	54	-20.712	359	Vertical	5	1 M	0	0.443
39.784 GHz	1	37.926	54	-16.074	121	Vertical	5	1 M	0	5.287

Frequency	SR #	Level (dBµV/m)	Limit (dBµV/m)	Margin (dB)	Azimuth (°)	Pol.	Meas. Time (s)	RBW (Hz)	Meas.Time (s)	Correction (dB)
16.107 GHz	2	34.911	54	-19.089	133	Horizontal	5	1 M	0	0.661
18.228 GHz	2	36.231	54	-17.769	287	Horizontal	5	1 M	0	-0.511
35.14 GHz	2	34.232	54	-19.768	311	Horizontal	5	1 M	0	2.575
39.994 GHz	2	38.99	54	-15.01	318	Horizontal	5	1 M	0	5.125

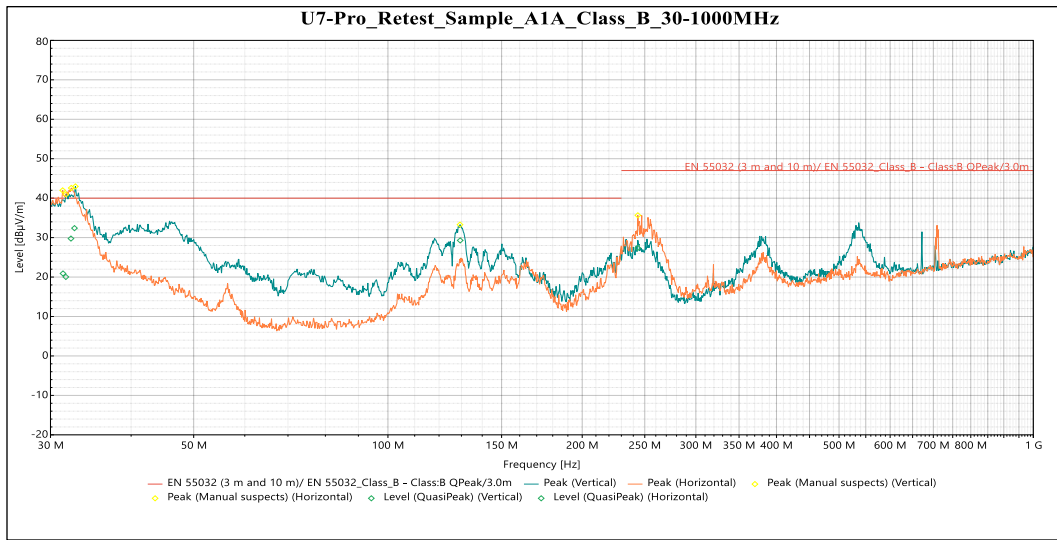
Graph 3: 17 GHz – 40 GHz Middle Channel (Worst Case)
5.5.4 UNII-2C

Frequency	SR #	Level (dBµV/m)	Limit (dBµV/m)	Margin	Azimuth (°)	Height	Pol.	Meas. Time	RBW (Hz)	Meas.Time (s)	Correction (dB)
31.692 MHz	1	20.029	40	-19.971	69	2.759	Vertical	15	120 k	0.001	-8.569
32.681 MHz	1	32.403	40	-7.597	199	1	Vertical	15	120 k	0.001	-9.148
129.41 MHz	1	29.287	40	-10.713	341	1.138	Vertical	15	120 k	0.001	-14.232
31.369 MHz	2	20.912	40	-19.088	251	1.143	Horizontal	15	120 k	0.001	-8.51
32.273 MHz	2	29.759	40	-10.241	50	3.298	Horizontal	15	120 k	0.001	-8.831
243.82 MHz	2	27.376	47	-19.624	278	1.52	Horizontal	15	120 k	0.001	-15.915

Graph 4: Radiated Emissions within 30MHz - 1GHz

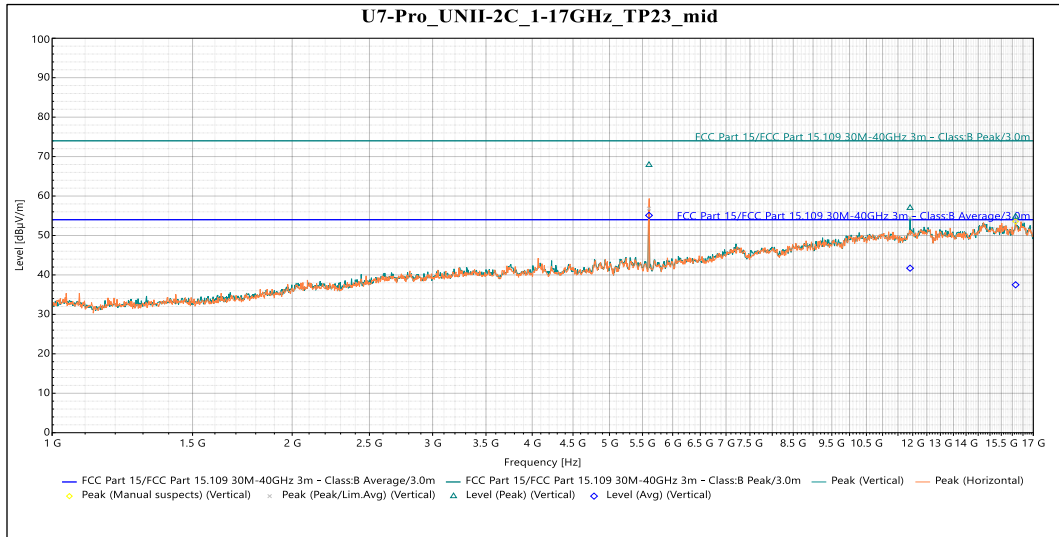

Final source: Peak

Frequency	SR #	Level (dBµV/m)	Limit (dBµV/m)	Margin (dB)	Azimuth (°)	Height (m)	Pol.	Meas. Time (s)	RBW (Hz)	Meas.Time (s)	Correction (dB)
11.91 GHz	1	56.992	74	-17.008	20	1.5	Vertical	15	1 M	0	16.544
16.152 GHz	1	54.748	74	-19.252	138	2.923	Vertical	15	1 M	0	17.436

Final source: Avg

Frequency	SR #	Level (dBµV/m)	Limit (dBµV/m)	Margin (dB)	Azimuth (°)	Height (m)	Pol.	Meas. Time (s)	RBW (Hz)	Meas.Time (s)	Correction (dB)
11.91 GHz	1	41.706	54	-12.294	20	1.5	Vertical	15	1 M	0	16.544
16.152 GHz	1	37.502	54	-16.498	138	2.923	Vertical	15	1 M	0	17.436

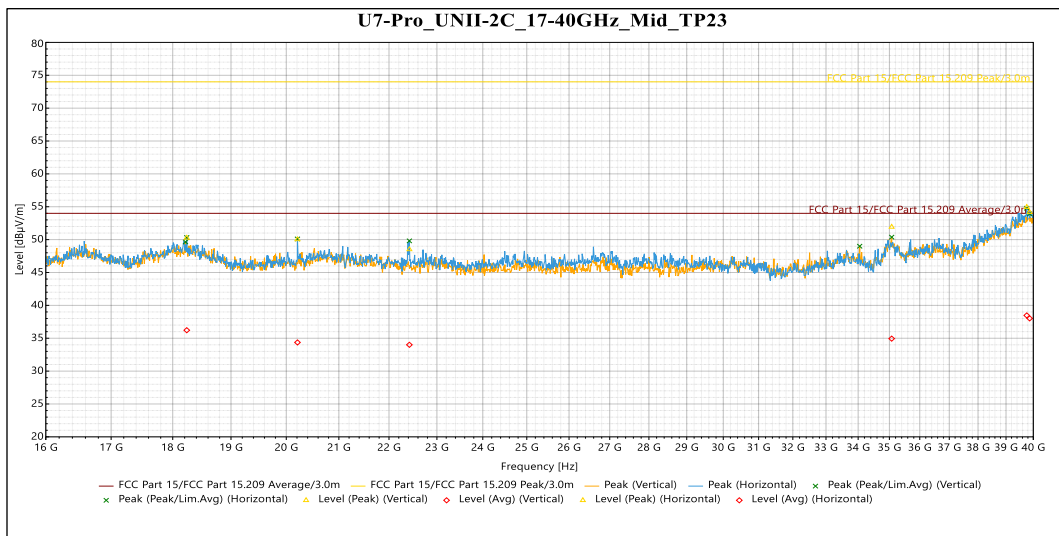
Graph 5: 1 GHz – 16 GHz Middle Channel (Worst Case)

Final source: Peak

Frequency	SR #	Level (dBµV/m)	Limit (dBµV/m)	Margin (dB)	Azimuth (°)	Pol.	Meas. Time (s)	RBW (Hz)	Meas.Time (s)	Correction (dB)
35.074 GHz	1	51.935	74	-22.065	265	Vertical	5	1 M	0	2.726

Frequency	SR #	Level (dBμV/m)	Limit (dBμV/m)	Margin (dB)	Azimuth (°)	Pol.	Meas. Time (s)	RBW (Hz)	Meas.Time (s)	Correction (dB)
39.864 GHz	1	54.156	74	-19.844	271	Vertical	5	1 M	0	5.225
18.236 GHz	2	50.273	74	-23.727	278	Horizontal	5	1 M	0	-0.511
20.209 GHz	2	50.026	74	-23.974	167	Horizontal	5	1 M	0	-0.867
22.42 GHz	2	48.513	74	-25.487	25	Horizontal	5	1 M	0	-1.229
39.758 GHz	2	54.946	74	-19.054	198	Horizontal	5	1 M	0	5.307

Final source: Avg

Frequency	SR #	Level (dBμV/m)	Limit (dBμV/m)	Margin (dB)	Azimuth (°)	Pol.	Meas. Time (s)	RBW (Hz)	Meas.Time (s)	Correction (dB)
35.074 GHz	1	34.943	54	-19.057	265	Vertical	5	1 M	0	2.726
39.864 GHz	1	38.023	54	-15.977	271	Vertical	5	1 M	0	5.225
18.236 GHz	2	36.223	54	-17.777	278	Horizontal	5	1 M	0	-0.511
20.209 GHz	2	34.361	54	-19.639	167	Horizontal	5	1 M	0	-0.867
22.42 GHz	2	34.005	54	-19.995	25	Horizontal	5	1 M	0	-1.229
39.758 GHz	2	38.47	54	-15.53	198	Horizontal	5	1 M	0	5.307

Graph 6: 16 GHz – 40 GHz Middle Channel (Worst Case)

5.6 §15.407(a) Maximum Power Spectral Density

All chains were measured and summed under the guidance of KDB 789033 Section II. F. and KDB 66291 D01. Please see associated annex for details on instrument settings.

The maximum average power spectral density conducted from the intentional radiator of the antenna shall not be greater than 11 dBm in any 1 MHz band during any time interval of continuous transmission.

Results of this testing are summarized. With a 6 dBi antenna, the conducted limit for power spectral density is 11 dBm. As per KDB 662911, When the EUT is using spatial-multiplexing in HT to HE modes, there is not additional array gain to accommodate. When the EUT uses N_{ss}=1 data rates, the antenna gain is 6 dBi + Array gain of 3.01 dB which is a total of 9.01 dBi

Results of this testing are summarized.

5.6.1 UNII-2A

Modulation (BW)	Frequency (MHz)	Data Rate	TP Setting	Conducted Output Power	Measured PSD
OFDM 20	5260	Mcs0_Nss4	21	23.48	10.84
OFDM 20	5280	Mcs0_Nss4	21	23.16	10.60
OFDM 20	5320	Mcs0_Nss4	21	23.06	10.46
HE20	5260	Mcs0_Nss4	21	23.59	10.11
HE20	5280	Mcs0_Nss4	21	23.25	9.90
HE20	5320	Mcs0_Nss4	21	23.18	9.72
HE40	5270	Mcs0_Nss4	21	23.54	7.03

HE40	5310	Mcs0_Nss4	21	23.42	6.82
HE80	5290	Mcs0_Nss4	21	23.06	3.58
HE160	5250	Mcs0_Nss4	21	23.53	1.18

Modulation (BW)	Frequency (MHz)	Data Rate	TP Setting	Conducted Output Power	Measured PSD
OFDM 20	5260	Mcs0_Nss1	18	20.48	7.84
OFDM 20	5280	Mcs0_Nss1	18	20.16	7.60
OFDM 20	5320	Mcs0_Nss1	18	20.06	7.46
HE20	5260	Mcs0_Nss1	18	20.59	7.11
HE20	5280	Mcs0_Nss1	19	21.25	7.90
HE20	5320	Mcs0_Nss1	19	21.18	7.72

5.6.2 UNII-2C

Modulation (BW)	Frequency (MHz)	Data Rate	TP Setting	Conducted Output Power	Measured PSD
OFDM 20	5500	Mcs0_Nss4	22	23.71	10.96
OFDM 20	5600	Mcs0_Nss4	21	22.85	10.34
OFDM 20	5720	Mcs0_Nss4	21	22.82	10.09
HE20	5500	Mcs0_Nss4	22	23.84	10.55
HE20	5600	Mcs0_Nss4	21	23.03	9.96
HE20	5720	Mcs0_Nss4	22	23.99	10.75
HE40	5510	Mcs0_Nss4	22	23.83	7.53
HE40	5590	Mcs0_Nss4	21	23.15	6.90
HE40	5710	Mcs0_Nss4	21	23.07	6.81
HE80	5530	Mcs0_Nss4	22	23.74	4.41
HE80	5610	Mcs0_Nss4	22	23.94	4.72
HE80	5690	Mcs0_Nss4	22	23.81	4.74
HE160	5570	Mcs0_Nss4	22	23.59	1.46

Modulation (BW)	Frequency (MHz)	Data Rate	TP Setting	Conducted Output Power	Measured PSD
OFDM 20	5500	Mcs0_Nss1	19	20.71	7.96
OFDM 20	5600	Mcs0_Nss1	18	19.85	7.34
OFDM 20	5720	Mcs0_Nss1	18	19.82	7.09
HE20	5500	Mcs0_Nss1	19	20.84	7.55
HE20	5600	Mcs0_Nss1	19	21.03	7.96
HE20	5720	Mcs0_Nss1	19	20.99	7.75

Result

The maximum average power spectral density was less than the limit of 8 dBm; therefore, the EUT complies with the specification.

5.7 DFS Requirement

This product is a master with radar detection. The outcome of the required DFS tests is located in this section. DFS testing was performed following the test procedures as outlined in KDB 905462.

The product passes all required DFS tests for a master with radar detection.

Information	Status	
Possible Antenna/s	Integral	
Antenna used for test	Integral	
Operating mode	Master	
If Client	NA	
Port used for testing	J1 and J2	
EIRP range	> 200 milliwatts	
Impedance of port	50 ohms	
Channel loading technique	Data transfer was enacted to achieve a minimum channel loading of approximately 17%	
Antenna measurement technique	See note 1	
Time of power-on cycle	80s2	
Detection threshold level	-64 dBm	

Requirement	Operational Mode		
	Master	Client Without Radar Detection	Client With Radar Detection
<i>Non-Occupancy Period</i>	Yes	Not Required	Yes
<i>DFS Detection Threshold</i>	Yes	Not Required	Yes
<i>Channel Availability Check Time</i>	Yes	Not Required	Not Required
<i>U-NII Detection Bandwidth</i>	Yes	Not Required	Yes

Requirement	Operational Mode	
	Master or Client Client Without Radar Detection	Client Without Radar Detection
<i>DFS Detection Threshold</i>	Yes	Not Required
<i>Channel Closing Transmission Time</i>	Yes	Yes
<i>Channel Move Time</i>	Yes	Yes
<i>U-NII Detection Bandwidth</i>	Yes	Not Required

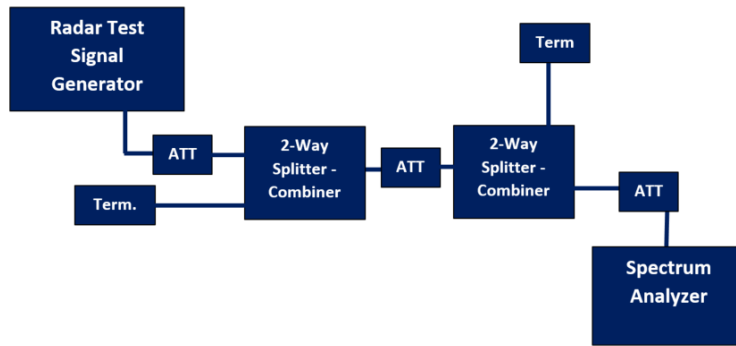

Maximum Transmit Power	Value (See Notes 1, 2, and 3)
EIRP \geq 200 milliwatt	-64 dBm
EIRP < 200 milliwatt and power spectral density < 10 dBm/MHz	-62 dBm
EIRP < 200 milliwatt that do not meet the power spectral density requirement	-64 dBm
<p>Note 1: This is the level at the input of the receiver assuming a 0 dBi receive antenna.</p> <p>Note 2: Throughout these test procedures an additional 1 dB has been added to the amplitude of the test transmission waveforms to account for variations in measurement equipment. This will ensure that the test signal is at or above the detection threshold level to trigger a DFS response.</p> <p>Note3: EIRP is based on the highest antenna gain. For MIMO devices refer to KDB Publication 662911 D01.</p>	

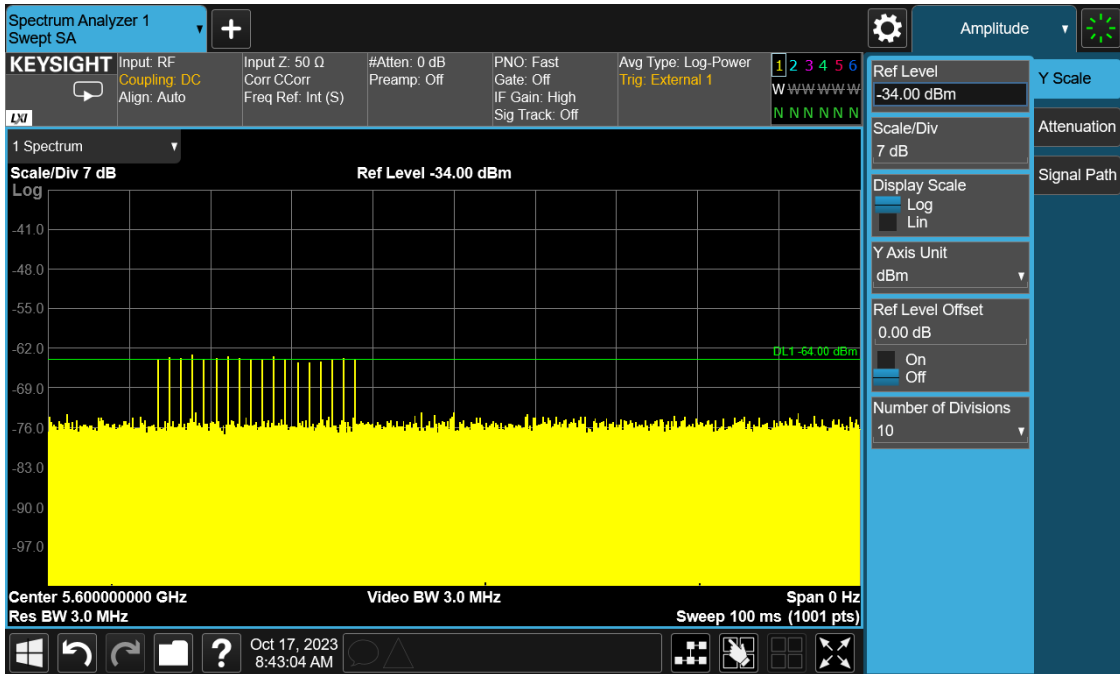

Plot 1: Radar Level 0

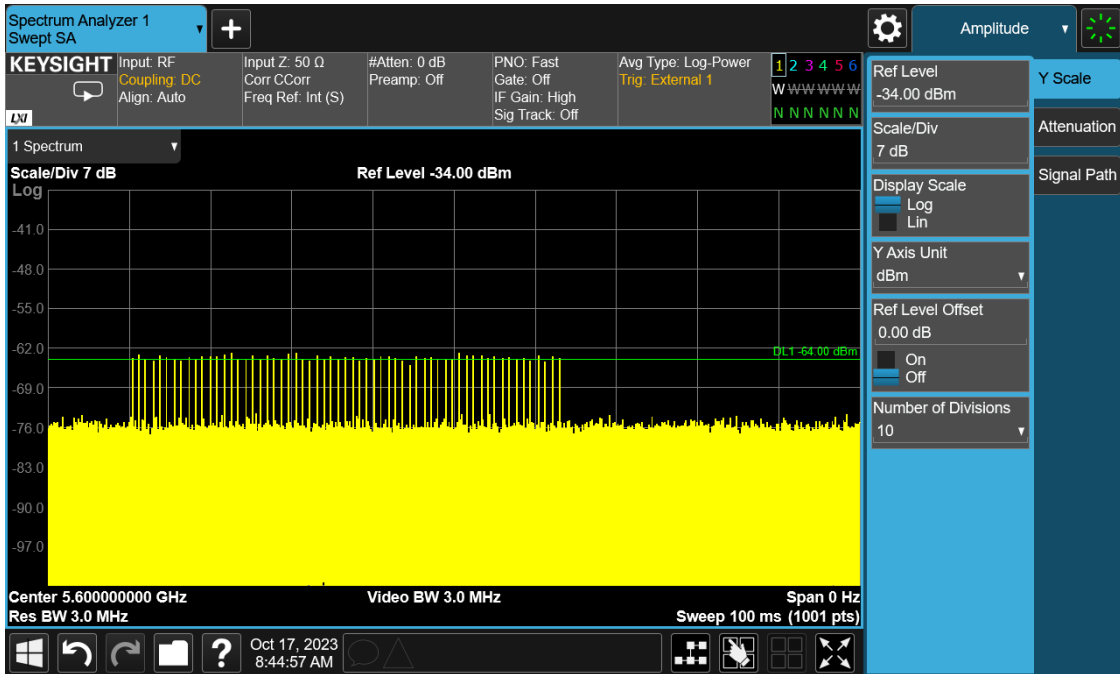

Plot 2: Radar Level 1

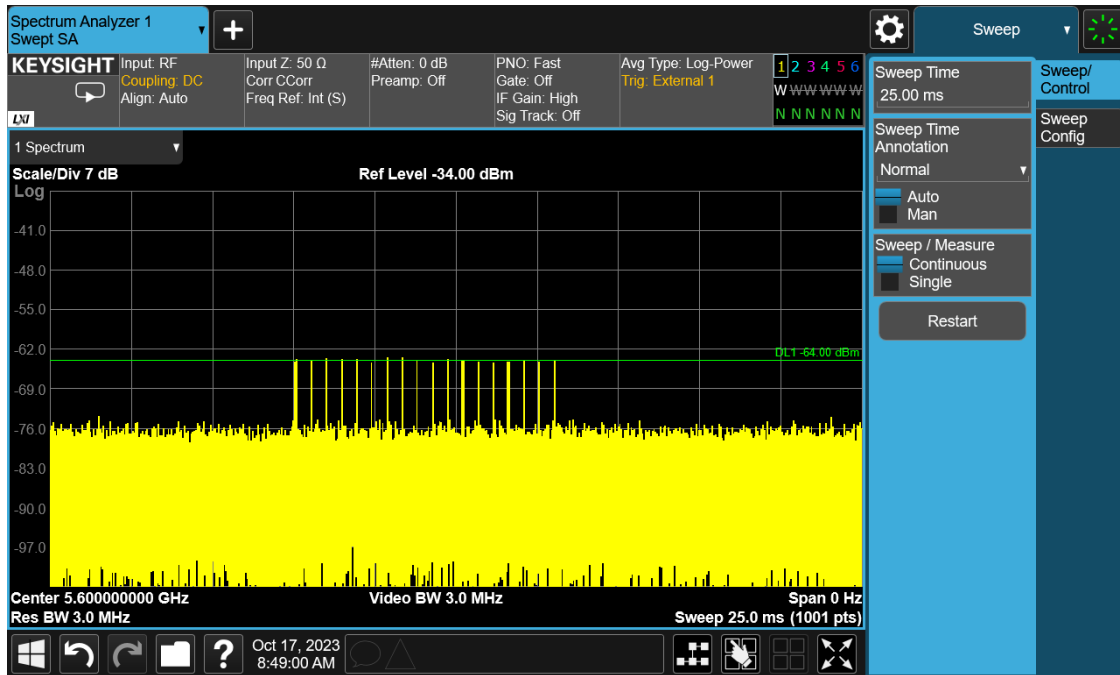
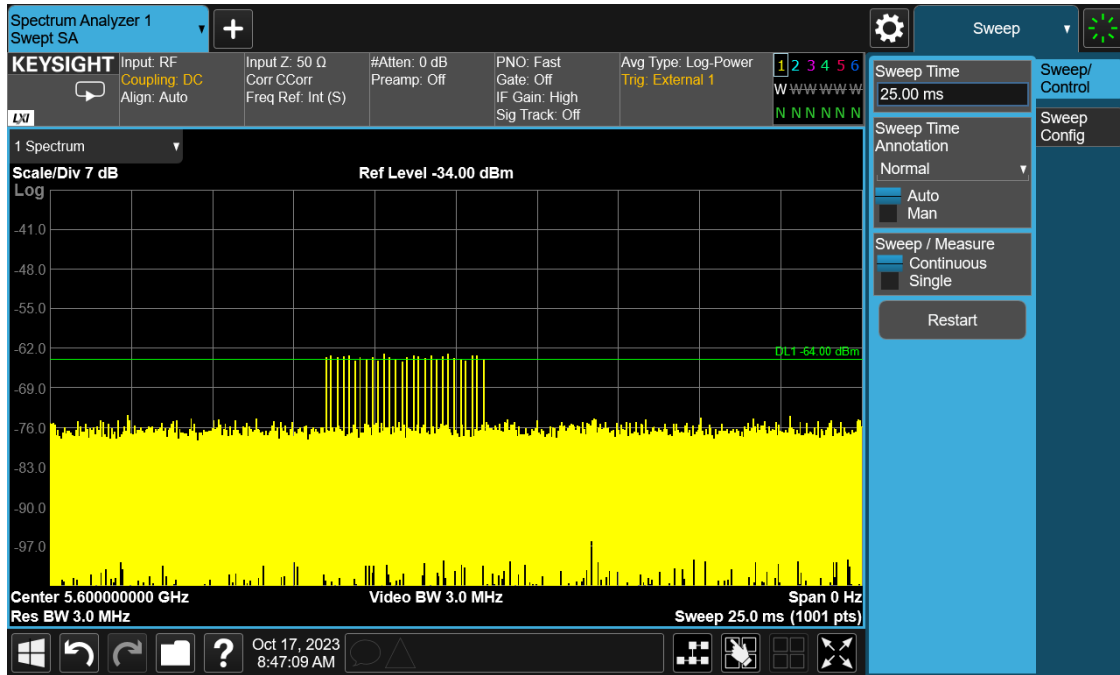

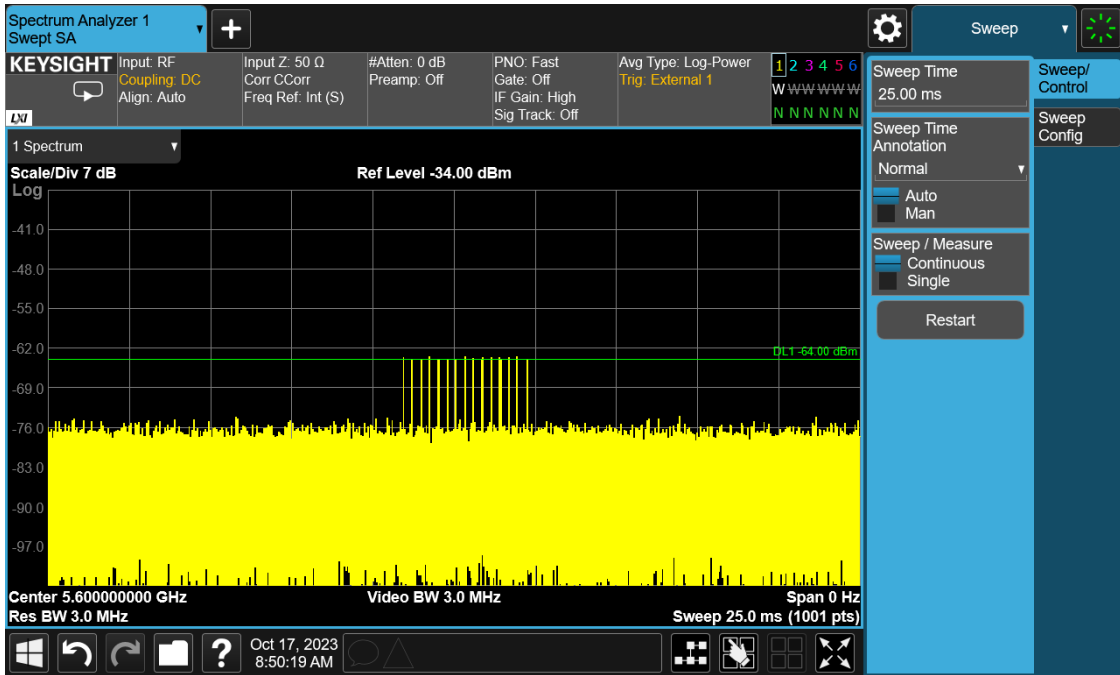

Plot 5: Radar Level 4

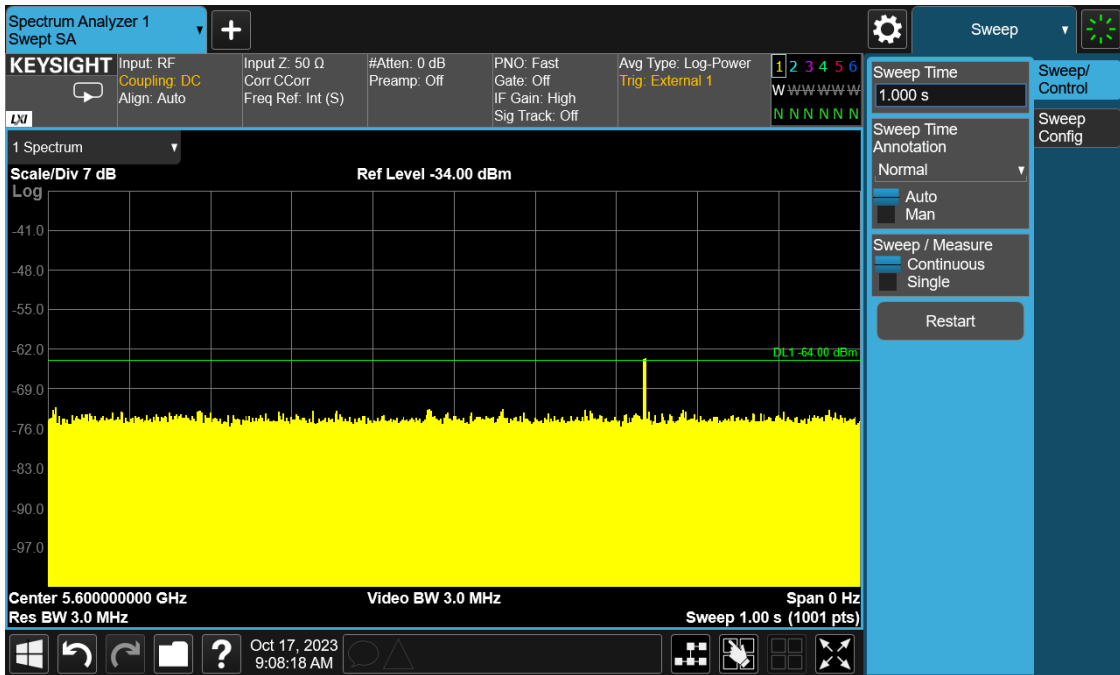

Plot 6: Radar Level 5

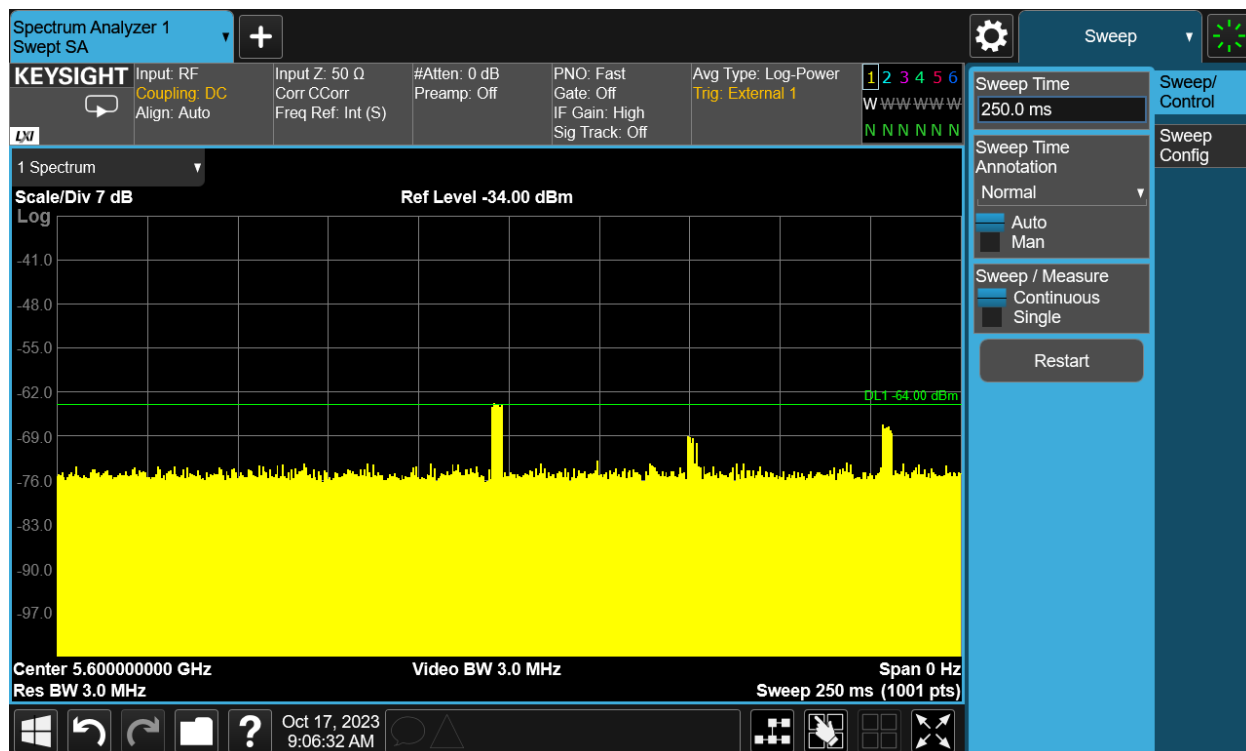

Plot 7: Radar Level 6

5.7.1 Channel Availability Check (CAC)

The EUT shall perform a CAC to ensure that there is no radar operating on the channel. After the power-up sequence, at-least 1 minute shall be monitored on the intended operating frequency. For initial CAC, the EUT does not emit beacon, control, or data signals on the test channel until the power-up sequence has been completed and the UNII device checks for radar waveforms for one minute on the test channel. This test does not use any radar waveforms. The markers in the associated plots indicate initial beacons.

For radar burst at the beginning of the CAC. To verify successful radar detection on the selected channel during a period equal to the beginning of the CAC time, visual indication on the EUT of successful detection of the radar burst will be recorded and reported. Observation of the radar burst is show on the associated plot to be within the beginning of the CAC time. Emissions will continue to be monitored for the remaining 300 seconds.

For radar burst at the end of the CAC. To verify successful radar detection on the selected channel during a period equal to the end of the CAC time, visual indication on the EUT of

successful detection of the radar burst will be recorded and reported. Observation of the radar burst is show on the associated plot to be within the end of the CAC time. Emissions will continue to be monitored for the remaining 300 seconds.

A spectrum analyzer is used as a monitor to verify that the EUT has vacated the channel within the channel closing transmission time and channel move time, and does not transmit on a channel during the non-occupancy period after the detection and channel move.

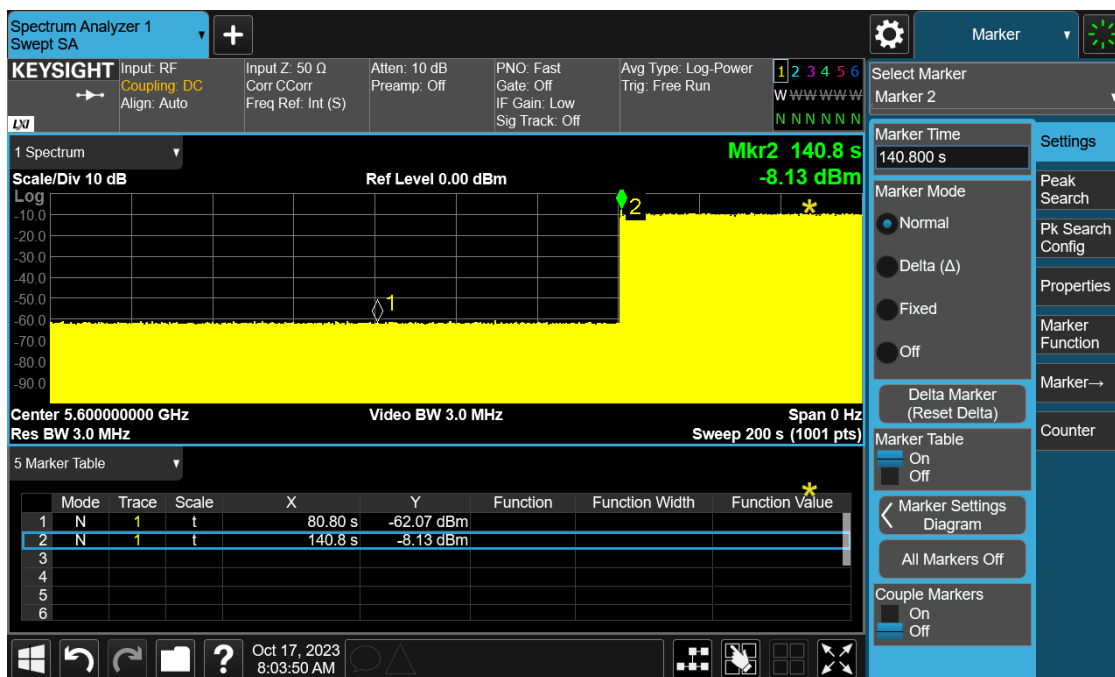

Plot 8: DUT Turn On

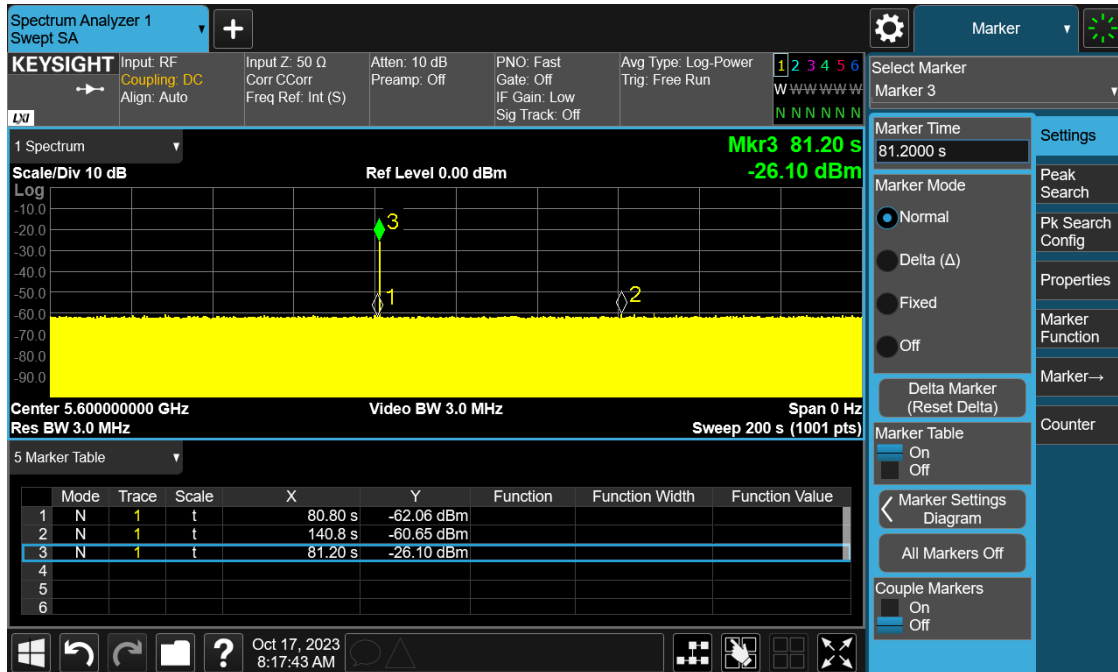

Plot 9: Beginning

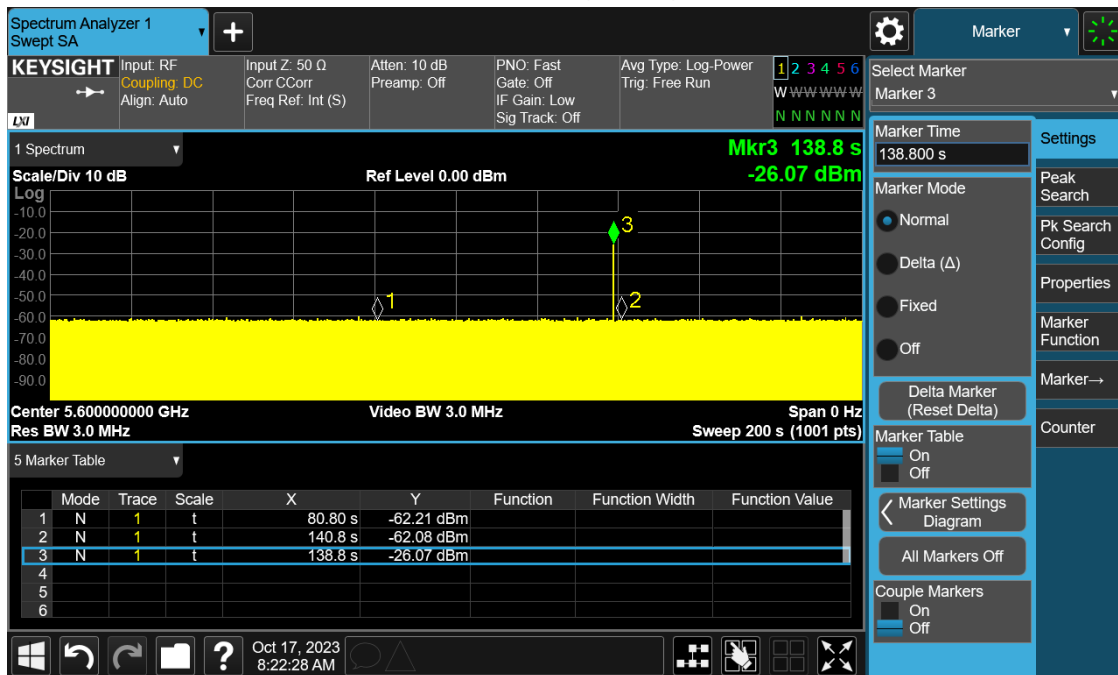

Plot 10: End

5.7.2 In-service Monitoring

Channel Move Time	10 seconds
Channel Closing Transmission Time	200 ms + aggregate of 60 ms over remaining 10 second period
Non-occupancy period	Minimum 30 minutes

Verified during in-service monitoring: channel closing transmission time and channel move time. The transmissions were observed at the end of the radar burst on the operating channel for a duration of greater than 10 seconds. The transmissions were measured and recorded during the observation time. This was compared to the channel move time and channel closing time limits. One 12 second plot is reported for the short pulse radar type 0. A 60 ms plot is also provided to verify closing time for the aggregate transmission time starting from 200 ms after the end of the radar signal to the completion of the channel move.

During the 30 minutes observation time, the EUT did not make any transmissions on a channel after a radar signal was detected.

Please see plots below.

A spectrum analyzer is used as a monitor to verify that the EUT has vacated the channel within the channel closing transmission time and channel move time, and does not transmit on a channel during the non-occupancy period after the detection and channel move.

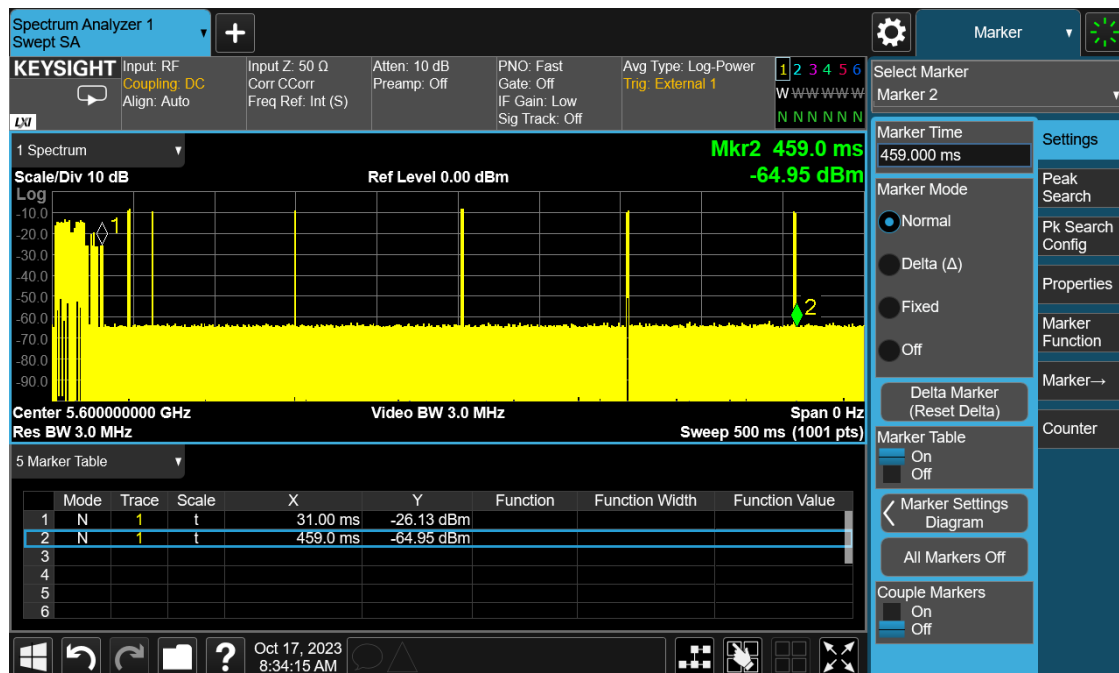

Plot 11: Channel Close (400 ms)

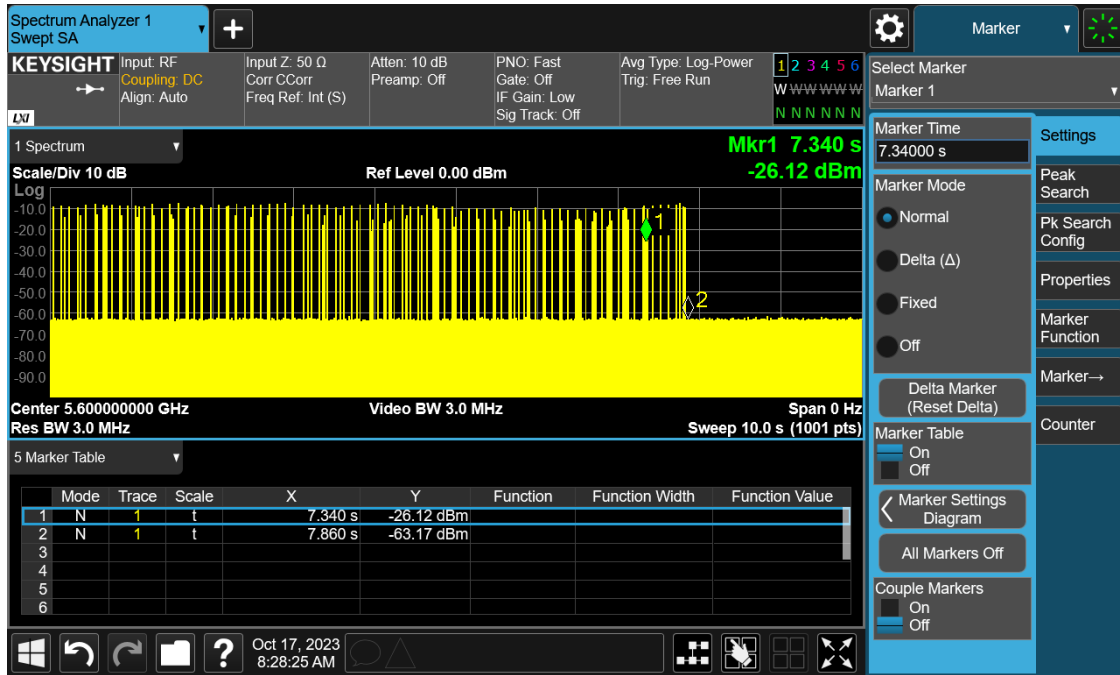

Plot 12: Channel Move

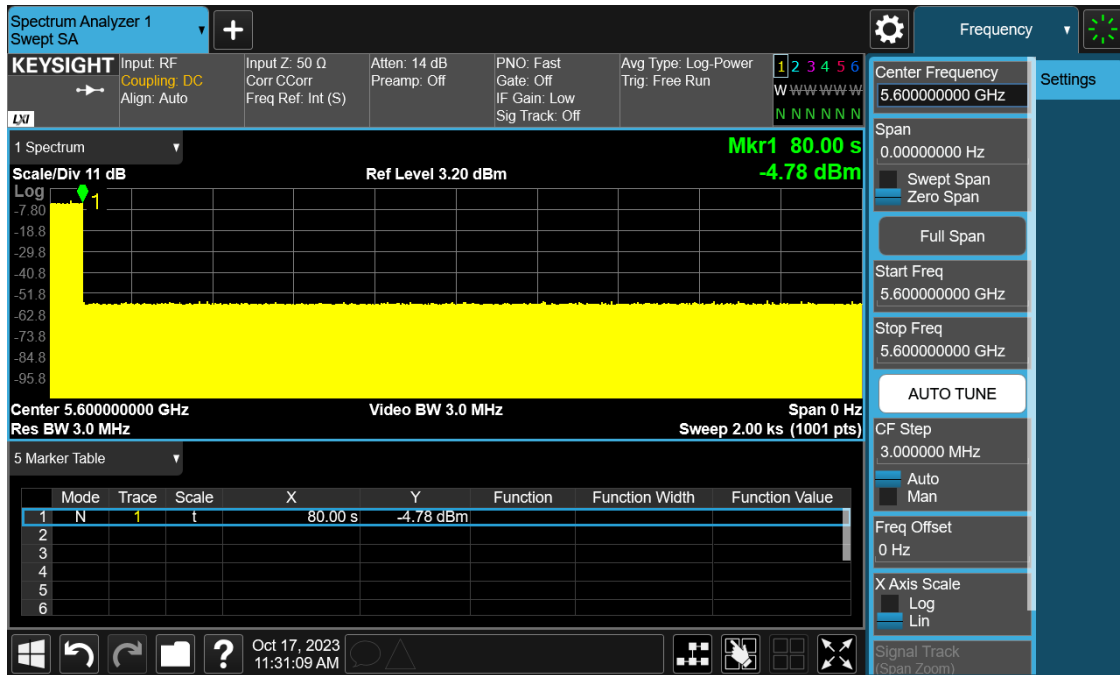

Plot 13: Non-Occupancy

5.7.3 DFS Detection Bandwidth

20 MHz

EUT Frequency = 5600 MHz ; Bandwidth = 20 MHz											
Radar Frequency MHz	DFS Detection Trials (1 = Detection, 0 = No Detection)										Detection Rate %
	Trials										
	1	2	3	4	5	6	7	8	9	10	
F_Low 5590	1	1	1	1	1	1	1	1	1	1	100
5595	1	1	1	1	1	1	1	1	1	1	100
5600	1	1	1	1	1	1	1	1	1	1	100
5605	1	1	1	1	1	1	1	1	1	1	100
F_High 5610	1	1	1	1	1	1	1	1	1	1	100
Total Detection Percentage											100
Detection Bandwidth = FH-FL = 5590 MHz - 5610 MHz = 20 MHz											
99% Bandwidth = 19.8 MHz											

40 MHz

EUT Frequency = 5590 MHz ; Bandwidth = 40 MHz											
Radar Frequency MHz	DFS Detection Trials (1 = Detection, 0 = No Detection)										Detection Rate %
	Trials										
	1	2	3	4	5	6	7	8	9	10	
F_Low 5570	1	1	1	1	1	1	1	1	1	1	100
5580	1	1	1	1	1	1	1	1	1	1	100
5590	1	1	1	1	1	1	1	1	1	1	100
5600	1	1	1	1	1	1	1	1	1	1	100
F_High 5610	1	1	1	1	1	1	1	1	1	1	100
Total Detection Percentage											100
Detection Bandwidth = FH-FL = 5570 MHz - 5610 MHz = 40 MHz											
99% Bandwidth = 39.6 MHz											

80 MHz

EUT Frequency = 5610 MHz ; Bandwidth = 80 MHz											
Radar Frequency MHz	DFS Detection Trials (1 = Detection, 0 = No Detection)										Detection Rate %
	Trials										
	1	2	3	4	5	6	7	8	9	10	
F_Low 5570	1	1	1	1	1	1	1	1	1	1	100
5590	1	1	1	1	1	1	1	1	1	1	100
5610	1	1	1	1	1	1	1	1	1	1	100
5630	1	1	1	1	1	1	1	1	1	1	100
F_High 5650	1	1	1	1	1	1	1	1	1	1	100
Total Detection Percentage											100
Detection Bandwidth = FH-FL = 5570 MHz - 5650 MHz = 80 MHz											
99% Bandwidth = 79.2 MHz											

160 MHz

EUT Frequency = 5570 MHz ; Bandwidth = 160 MHz												
Radar Frequency MHz	DFS Detection Trials (1 = Detection, 0 = No Detection)										Detection Rate %	
	Trials											
	1	2	3	4	5	6	7	8	9	10		
F_Low 5490	1	1	1	1	1	1	1	1	1	1	1	100
5530	1	1	1	1	1	1	1	1	1	1	1	100
5570	1	1	1	1	1	1	1	1	1	1	1	100
5610	1	1	1	1	1	1	1	1	1	1	1	100
F_High 5650	1	1	1	1	1	1	1	1	1	1	1	100
Total Detection Percentage											100	
Detection Bandwidth = FH-FL = 5490 MHz - 5650 MHz = 160 MHz												
99% Bandwidth = 158.4 MHz												

5.7.4 Detection Probability

For statistical performance check. Demonstrating a minimum channel loading of approximately 17% or greater of the test. Observe the transmissions of the EUT at the end of the burst on the operating channel for duration greater than 10 seconds for short pulse radar type 1-4 and 6 to ensure detection occurs. Then observe the transmissions of the EUT at the end of the burst on the operating channel for duration greater than 22 seconds for long pulse radar type 5 to ensure detection occurs. The device can utilize a test mode to demonstrate when detection occurs to prevent the need to reset the device between trial runs.

Please see data below.

Radar Type	Min successful detection (%)	Maximum Trials
1	60	30
2	60	30
3	60	30
4	60	30
Types 1 - 4	80	120
5	80	30
6	70	30

20 MHz

Summary			
Type	Detections	Trials	Detection Probability
Type 1	27	30	90%
Type 2	29	30	97%
Type 3	27	30	90%
Type 4	21	30	70%
Type 5	29	30	97%
Type 6	29	30	97%
Aggregate 1-4	104	120	87%

RADAR TYPE 1					RADAR TYPE 2				
Rohde & Schwarz K350 Pulse Sequencer DFS					Rohde & Schwarz K350 Pulse Sequencer DFS				
Trial #	Number of Pulses per Burst	Pulse Width (µsec)	PRI (µs)	Detection (yes/no)	Trial #	Number of Pulses per Burst	Pulse Width (µsec)	PRI (µs)	Detection (yes/no)
1	67	1	787	y	1	25	3.5	151	y
2	21	1	2575	y	2	26	1.6	182	y
3	21	1	2633	n	3	28	4.3	192	y
4	21	1	2549	n	4	24	1.5	202	y
5	22	1	2473	y	5	26	4.2	211	y
6	22	1	2439	y	6	26	4.7	175	y
7	23	1	2346	y	7	27	4.5	168	y
8	64	1	832	y	8	24	2.5	228	y
9	22	1	2441	y	9	25	2.6	228	y
10	21	1	2619	y	10	27	4.2	155	y
11	27	1	1972	y	11	29	1.5	190	y
12	37	1	1463	y	12	24	3.4	182	y
13	28	1	1886	y	13	25	2.6	223	y
14	62	1	854	y	14	29	2.1	219	y
15	20	1	2640	y	15	28	4.4	154	y
16	21	1	2550	y	16	27	3.3	226	y
17	69	1	771	y	17	27	2.7	211	y
18	18	1	2988	y	18	23	3.1	214	y
19	66	1	807	y	19	25	1.5	221	y
20	56	1	946	y	20	27	1.6	216	y
21	34	1	1587	y	21	28	1.9	194	y
22	63	1	845	y	22	26	3.4	196	y
23	24	1	2258	y	23	28	1.8	163	y
24	54	1	982	y	24	24	1.9	222	y
25	18	1	3059	y	25	24	4.7	171	y
26	28	1	1936	n	26	23	1.5	196	y
27	22	1	2462	y	27	24	4.3	193	y
28	18	1	3013	y	28	27	1.5	215	y
29	36	1	1464	y	29	26	2.3	224	y
30	32	1	1652	y	30	29	1	192	n
27/30: 90%					29/30: 96.7%				

RADAR TYPE 3					RADAR TYPE 4				
Rohde & Schw arz K350 Pulse Sequencer DFS					Rohde & Schw arz K350 Pulse Sequencer DFS				
Trial #	Number of Pulses per Burst	Pulse Width (µsec)	PRI (µs)	Detection (yes/no)	Trial #	Number of Pulses per Burst	Pulse Width (µsec)	PRI (µs)	Detection (yes/no)
1	16	6.4	312	y	1	14	16.2	251	y
2	18	8.6	233	y	2	13	18	431	n
3	17	6.2	236	y	3	14	15.2	303	y
4	16	9	436	y	4	15	12.9	412	y
5	17	8	339	y	5	14	13.9	230	y
6	16	9.6	220	y	6	14	14.1	374	y
7	17	6.7	432	y	7	16	19	407	y
8	17	9.7	223	y	8	14	12.5	208	y
9	18	6.6	386	y	9	16	12.8	216	n
10	17	6.2	383	y	10	13	11.7	395	y
11	17	7.8	444	n	11	12	12.3	367	y
12	16	7.7	379	y	12	15	15.8	278	n
13	17	7.2	405	y	13	13	19.3	339	y
14	17	6.8	347	y	14	14	18.7	261	y
15	16	6.1	375	y	15	15	18	434	y
16	17	6.1	293	y	16	16	13.6	298	y
17	17	7.9	212	y	17	13	16.9	287	y
18	17	7.3	365	y	18	12	19.3	461	y
19	17	9.7	457	y	19	12	15.9	486	n
20	16	8.6	309	y	20	14	14.9	382	y
21	16	9	287	y	21	14	15.3	335	n
22	18	8	418	y	22	13	14.2	239	y
23	17	7.8	460	y	23	13	13.8	247	y
24	17	6.6	468	n	24	13	18.7	453	y
25	17	8.9	389	y	25	15	18.1	332	y
26	18	7	442	n	26	16	17.3	225	n
27	18	6.6	374	y	27	15	11.5	285	n
28	16	7.1	429	y	28	14	19.8	324	n
29	17	8.4	343	y	29	15	14.6	262	n
30	17	8.1	237	y	30	16	16.9	215	y
27/30: 90%					21/30: 70%				

TYPE 5				
Rohde & Schw arz K350 Pulse Sequencer DFS				
Trial #	Detection (yes/no)	Chirp Width (MHz)	Subset	Fc
1	y	5	1	5600
2	y	16	1	5600
3	y	18	1	5600
4	y	13	1	5600
5	y	12	1	5600
6	y	10	1	5600
7	n	16	1	5600
8	y	17	1	5600
9	y	14	1	5600
10	y	9	1	5600
11	y	18	2	5597.2
12	y	9	2	5593.6
13	y	9	2	5593.6
14	y	5	2	5592
15	y	16	2	5596.4
16	y	5	2	5592
17	y	19	2	5597.6
18	y	5	2	5592
19	y	8	2	5593.2
20	y	9	2	5593.6
21	y	14	3	5604.4
22	y	17	3	5603.2
23	y	16	3	5603.6
24	y	18	3	5602.8
25	y	19	3	5602.4
26	y	16	3	5603.6
27	y	5	3	5608
28	y	14	3	5604.4
29	y	9	3	5606.4
30	y	19	3	5602.4
29/30: 96.7%				

TYPE 6 S	
Rohde & Schwarz K350 Pulse Sequencer DFS	
Trial #	Detection (yes/no)
1	y
2	y
3	y
4	y
5	y
6	y
7	y
8	y
9	y
10	y
11	y
12	y
13	y
14	y
15	y
16	y
17	y
18	y
19	y
20	y
21	y
22	y
23	y
24	y
25	y
26	y
27	y
28	y
29	n
30	y
29/30: 96.7%	

40 MHz

Summary			
Type	Detections	Trials	Detection Probability
Type 1	30	30	100%
Type 2	24	30	80%
Type 3	27	30	90%
Type 4	26	30	87%
Type 5	30	30	100%
Type 6	29	30	97%
Aggregate 1-4	107	120	89%

RADAR TYPE 1					RADAR TYPE 2				
Rohde & Schw arz K350 Pulse Sequencer DFS					Rohde & Schw arz K350 Pulse Sequencer DFS				
Trial #	Number of Pulses per Burst	Pulse Width (µsec)	PRI (µs)	Detection (yes/no)	Trial #	Number of Pulses per Burst	Pulse Width (µsec)	PRI (µs)	Detection (yes/no)
1	24	1	2211	y	1	28	2.1	164	y
2	24	1	2225	y	2	24	2.2	177	n
3	49	1	1084	y	3	26	1	160	y
4	47	1	1123	y	4	25	4.6	161	y
5	65	1	813	y	5	24	2.6	208	y
6	19	1	2832	y	6	26	2.9	221	y
7	31	1	1740	y	7	25	1.5	180	n
8	25	1	2137	y	8	26	3.8	160	y
9	51	1	1037	y	9	27	3.7	219	y
10	33	1	1601	y	10	27	4.5	227	n
11	41	1	1286	y	11	26	2.5	169	y
12	68	1	782	y	12	25	3.8	220	y
13	50	1	1062	y	13	24	1.4	223	y
14	40	1	1335	y	14	25	4.1	200	y
15	26	1	2085	y	15	27	4.9	190	y
16	53	1	1013	y	16	27	2.1	189	y
17	33	1	1631	y	17	24	4.9	180	y
18	88	1	604	y	18	27	2.9	170	y
19	42	1	1280	y	19	28	2.9	211	y
20	73	1	729	y	20	27	2.9	179	n
21	35	1	1508	y	21	27	4.7	163	n
22	73	1	724	y	22	24	1.1	212	y
23	71	1	744	y	23	29	3	173	y
24	35	1	1513	y	24	26	2	179	y
25	20	1	2756	y	25	27	4	160	y
26	21	1	2522	y	26	28	2.6	172	y
27	27	1	2015	y	27	26	2.9	218	n
28	27	1	1964	y	28	24	3.9	218	y
29	25	1	2108	y	29	28	3.8	211	y
30	27	1	2007	y	30	28	1	210	y
30/30: 100%					24/30: 80%				

RADAR TYPE 3					RADAR TYPE 4				
Rohde & Schw arz K350 Pulse Sequencer DFS					Rohde & Schw arz K350 Pulse Sequencer DFS				
Trial #	Number of Pulses per Burst	Pulse Width (µsec)	PRI (µs)	Detection (yes/no)	Trial #	Number of Pulses per Burst	Pulse Width (µsec)	PRI (µs)	Detection (yes/no)
1	17	6.2	403	y	1	16	11.4	231	y
2	16	8.3	445	y	2	14	11.4	266	n
3	18	6.9	454	y	3	13	15.4	355	y
4	17	6.9	359	y	4	14	17.1	405	y
5	17	8.4	352	y	5	14	11.7	351	y
6	17	6.2	282	y	6	12	18.6	287	y
7	17	6.6	379	n	7	16	14.7	349	y
8	17	8.1	372	y	8	15	12.6	328	y
9	17	8	263	y	9	16	16.3	274	y
10	17	7.9	478	y	10	13	13.3	311	y
11	17	8.7	475	y	11	15	16.4	287	y
12	17	8.8	440	y	12	16	19.8	473	y
13	17	7.6	247	y	13	14	15.4	264	n
14	17	8.9	287	y	14	15	17.1	377	y
15	16	7.1	336	y	15	15	18.7	328	y
16	17	6.3	499	y	16	12	15.9	453	n
17	18	8.3	282	y	17	15	17.9	203	y
18	16	8.3	441	y	18	13	18.9	352	y
19	18	7.9	312	y	19	13	18.8	321	y
20	18	9.9	497	y	20	14	18.2	259	y
21	17	9	451	y	21	13	12.4	332	y
22	16	8.4	316	y	22	15	15.5	367	y
23	18	8.9	408	n	23	14	17.9	350	n
24	17	7.9	341	y	24	16	18.3	320	y
25	18	7.1	339	y	25	13	12.6	286	y
26	16	7.9	479	y	26	13	15.1	401	y
27	17	8.9	414	n	27	14	12.5	288	y
28	17	8.1	472	y	28	14	15.1	340	y
29	17	6.5	317	y	29	15	12.2	383	y
30	17	8.1	285	y	30	14	18.8	233	y
27/30: 90%					26/30: 86.7%				

TYPE 5		Rohde & Schwarz K350 Pulse Sequencer DFS		
Trial #	Detection (yes/no)	Chirp Width (MHz)	Subset	Fc
1	y	6	1	5600
2	y	6	1	5600
3	y	7	1	5600
4	y	14	1	5600
5	y	10	1	5600
6	y	6	1	5600
7	y	19	1	5600
8	y	6	1	5600
9	y	13	1	5600
10	y	15	1	5600
11	y	14	2	5575.6
12	y	13	2	5575.2
13	y	11	2	5574.4
14	y	18	2	5577.2
15	y	9	2	5573.6
16	y	15	2	5576
17	y	11	2	5574.4
18	y	19	2	5577.6
19	y	16	2	5576.4
20	y	13	2	5575.2
21	y	6	3	5607.6
22	y	5	3	5608
23	y	16	3	5603.6
24	y	7	3	5607.2
25	y	7	3	5607.2
26	y	5	3	5608
27	y	15	3	5604
28	y	14	3	5604.4
29	y	18	3	5602.8
30	y	6	3	5607.6
30/30: 100%				

TYPE 6 S		Rohde & Schwarz K350 Pulse Sequencer DFS
Trial #	Detection (yes/no)	
1	y	
2	y	
3	n	
4	y	
5	y	
6	y	
7	y	
8	y	
9	y	
10	y	
11	y	
12	y	
13	y	
14	y	
15	y	
16	y	
17	y	
18	y	
19	y	
20	y	
21	y	
22	y	
23	y	
24	y	
25	y	
26	y	
27	y	
28	y	
29	y	
30	y	
29/30: 96.7%		

80 MHz

Summary			
Type	Detections	Trials	Detection Probability
Type 1	29	30	97%
Type 2	28	30	93%
Type 3	25	30	83%
Type 4	28	30	93%
Type 5	30	30	100%
Type 6	30	30	100%
Aggregate 1-4	110	120	92%

RADAR TYPE 1					RADAR TYPE 2				
Rohde & Schwarz K350 Pulse Sequencer DFS					Rohde & Schwarz K350 Pulse Sequencer DFS				
Trial #	Number of Pulses per Burst	Pulse Width (µsec)	PRI (µs)	Detection (yes/no)	Trial #	Number of Pulses per Burst	Pulse Width (µsec)	PRI (µs)	Detection (yes/no)
1	23	1	2325	y	1	24	4.7	155	y
2	57	1	939	y	2	27	3.5	181	y
3	33	1	1604	y	3	25	3.8	159	y
4	43	1	1246	y	4	27	3.9	206	y
5	19	1	2809	y	5	24	2.3	155	y
6	19	1	2833	y	6	28	1.7	215	y
7	22	1	2477	y	7	26	1.9	182	n
8	35	1	1521	y	8	24	2.3	178	y
9	20	1	2679	y	9	28	3.6	226	y
10	90	1	588	y	10	26	3	157	y
11	27	1	2023	y	11	28	4.1	194	y
12	44	1	1224	y	12	29	3.4	151	y
13	21	1	2573	y	13	27	2.7	152	y
14	18	1	2975	n	14	27	1.7	186	y
15	37	1	1430	y	15	29	3.7	182	y
16	77	1	691	y	16	28	2.6	160	y
17	18	1	2986	y	17	25	1.5	192	y
18	38	1	1415	y	18	24	3.1	154	y
19	23	1	2350	y	19	23	2.1	197	y
20	40	1	1347	y	20	24	2.1	159	y
21	69	1	769	y	21	28	3.9	204	y
22	25	1	2109	y	22	25	1	150	y
23	22	1	2424	y	23	25	1.2	182	y
24	42	1	1274	y	24	27	4.6	201	y
25	25	1	2163	y	25	26	2.1	184	y
26	25	1	2157	y	26	26	4.6	198	y
27	39	1	1374	y	27	27	4.2	208	y
28	49	1	1095	y	28	29	2.9	184	y
29	87	1	606	y	29	26	3.6	191	y
30	37	1	1436	y	30	27	1.6	226	n
29/30: 96.7%					28/30: 93.3%				

RADAR TYPE 3					RADAR TYPE 4				
Rohde & Schw arz K350 Pulse Sequencer DFS					Rohde & Schw arz K350 Pulse Sequencer DFS				
Trial #	Number of Pulses per Burst	Pulse Width (µsec)	PRI (µs)	Detection (yes/no)	Trial #	Number of Pulses per Burst	Pulse Width (µsec)	PRI (µs)	Detection (yes/no)
1	17	8.2	392	y	1	14	11.2	392	y
2	16	6.8	383	y	2	14	17.5	445	y
3	17	8.1	477	n	3	12	17.4	472	y
4	18	9.4	339	y	4	15	17	488	y
5	17	8.5	378	y	5	12	14.3	277	y
6	16	8.6	336	y	6	13	14.1	431	y
7	16	7.2	345	y	7	15	13	314	n
8	16	9.1	401	y	8	15	14.6	444	y
9	16	7.7	472	y	9	12	14.2	432	y
10	17	9.9	465	y	10	14	16.9	260	y
11	17	6.6	237	n	11	13	17.5	457	n
12	18	9	324	y	12	14	15.6	442	y
13	18	7.1	345	y	13	15	17.5	201	y
14	16	8.5	477	y	14	15	17.3	369	y
15	17	9.5	308	y	15	14	15.1	210	y
16	17	7.9	278	y	16	13	11.4	378	y
17	18	9.6	421	y	17	16	13.9	321	y
18	17	9.2	400	y	18	15	13	328	y
19	18	8.4	405	y	19	14	14.5	356	y
20	16	6.8	328	y	20	14	14.4	449	y
21	17	7.2	404	y	21	14	13.5	306	y
22	17	8.1	385	n	22	15	18.2	236	y
23	18	6	338	n	23	13	11.9	486	y
24	18	7.6	463	n	24	12	15.9	263	y
25	17	8.5	433	y	25	16	19.5	347	y
26	18	9.4	484	y	26	16	16	353	y
27	16	6	496	y	27	15	11	498	y
28	16	7.6	400	y	28	14	11.1	218	y
29	17	7.5	408	y	29	13	11.3	426	y
30	16	7.7	488	y	30	15	17.2	378	y
25/30: 83.3%					28/30: 93.3%				

TYPE 5				
Rohde & Schw arz K350 Pulse Sequencer DFS				
Trial #	Detection (yes/no)	Chirp Width (MHz)	Subset	Fc
1	y	5	1	5600
2	y	6	1	5600
3	y	13	1	5600
4	y	14	1	5600
5	y	18	1	5600
6	y	6	1	5600
7	y	8	1	5600
8	y	7	1	5600
9	y	12	1	5600
10	y	10	1	5600
11	y	13	2	5575.2
12	y	16	2	5576.4
13	y	11	2	5574.4
14	y	16	2	5576.4
15	y	14	2	5575.6
16	y	16	2	5576.4
17	y	10	2	5574
18	y	12	2	5574.8
19	y	6	2	5572.4
20	y	16	2	5576.4
21	y	19	3	5642.4
22	y	16	3	5643.6
23	y	7	3	5647.2
24	y	6	3	5647.6
25	y	6	3	5647.6
26	y	16	3	5643.6
27	y	11	3	5645.6
28	y	7	3	5647.2
29	y	16	3	5643.6
30	y	17	3	5643.2

TYPE 6 S	
Rohde & Schwarz K350 Pulse Sequencer DFS	
Trial #	Detection (yes/no)
1	y
2	y
3	y
4	y
5	y
6	y
7	y
8	y
9	y
10	y
11	y
12	y
13	y
14	y
15	y
16	y
17	y
18	y
19	y
20	y
21	y
22	y
23	y
24	y
25	y
26	y
27	y
28	y
29	y
30	y
30/30: 100%	

160 MHz

Summary			
Type	Detections	Trials	Detection Probability
Type 1	29	30	97%
Type 2	26	30	87%
Type 3	20	30	67%
Type 4	26	30	87%
Type 5	27	30	90%
Type 6	29	30	97%
Aggregate 1-4	101	120	84%

RADAR TYPE 1					RADAR TYPE 2				
Rohde & Schw arz K350 Pulse Sequencer DFS					Rohde & Schw arz K350 Pulse Sequencer DFS				
Trial #	Number of Pulses per Burst	Pulse Width (µsec)	PRI (µs)	Detection (yes/no)	Trial #	Number of Pulses per Burst	Pulse Width (µsec)	PRI (µs)	Detection (yes/no)
1	23	1	2325	y	1	24	4.7	155	y
2	57	1	939	y	2	27	3.5	181	y
3	33	1	1604	y	3	25	3.8	159	n
4	43	1	1246	y	4	27	3.9	206	n
5	19	1	2809	y	5	24	2.3	155	y
6	19	1	2833	y	6	28	1.7	215	y
7	22	1	2477	y	7	26	1.9	182	y
8	35	1	1521	y	8	24	2.3	178	y
9	20	1	2679	y	9	28	3.6	226	y
10	90	1	588	y	10	26	3	157	y
11	27	1	2023	y	11	28	4.1	194	y
12	44	1	1224	y	12	29	3.4	151	y
13	21	1	2573	y	13	27	2.7	152	y
14	18	1	2975	y	14	27	1.7	186	y
15	37	1	1430	y	15	29	3.7	182	y
16	77	1	691	y	16	28	2.6	160	n
17	18	1	2986	y	17	25	1.5	192	n
18	38	1	1415	y	18	24	3.1	154	y
19	23	1	2350	y	19	23	2.1	197	y
20	40	1	1347	y	20	24	2.1	159	y
21	69	1	769	y	21	28	3.9	204	y
22	25	1	2109	y	22	25	1	150	y
23	22	1	2424	n	23	25	1.2	182	y
24	42	1	1274	y	24	27	4.6	201	y
25	25	1	2163	y	25	26	2.1	184	y
26	25	1	2157	y	26	26	4.6	198	y
27	39	1	1374	y	27	27	4.2	208	y
28	49	1	1095	y	28	29	2.9	184	y
29	87	1	606	y	29	26	3.6	191	y
30	37	1	1436	y	30	27	1.6	226	y
29/30: 96.7%					26/30: 86.7%				

RADAR TYPE 3					RADAR TYPE 4				
Rohde & Schw arz K350 Pulse Sequencer DFS					Rohde & Schw arz K350 Pulse Sequencer DFS				
Trial #	Number of Pulses per Burst	Pulse Width (µsec)	PRI (µs)	Detection (yes/no)	Trial #	Number of Pulses per Burst	Pulse Width (µsec)	PRI (µs)	Detection (yes/no)
1	17	8.2	392	y	1	13	14.5	286	y
2	16	6.8	383	n	2	12	18.7	225	y
3	17	8.1	477	y	3	13	11.2	432	n
4	18	9.4	339	n	4	12	12.6	235	y
5	17	8.5	378	y	5	14	11.5	204	y
6	16	8.6	336	y	6	15	19	442	y
7	16	7.2	345	y	7	15	13.3	427	y
8	16	9.1	401	y	8	12	19.4	327	y
9	16	7.7	472	y	9	16	18.5	231	y
10	17	9.9	465	y	10	13	16.1	251	y
11	17	6.6	237	n	11	13	11.7	301	y
12	18	9	324	y	12	15	15.1	475	y
13	18	7.1	345	y	13	14	12.3	248	y
14	16	8.5	477	y	14	13	12.8	324	y
15	17	9.5	308	y	15	12	17.1	285	y
16	17	7.9	278	n	16	13	13.2	337	y
17	18	9.6	421	y	17	16	13.7	322	n
18	17	9.2	400	y	18	14	19.1	346	n
19	18	8.4	405	y	19	15	16.9	438	y
20	16	6.8	328	y	20	15	17.5	432	n
21	17	7.2	404	n	21	14	14.5	339	y
22	17	8.1	385	n	22	15	19	218	y
23	18	6	338	n	23	14	16	347	y
24	18	7.6	463	n	24	16	17.3	262	y
25	17	8.5	433	y	25	15	13.4	309	y
26	18	9.4	484	y	26	14	11.8	253	y
27	16	6	496	n	27	12	13.3	305	y
28	16	7.6	400	y	28	15	12.2	359	y
29	17	7.5	408	y	29	16	11.4	497	y
30	16	7.7	488	n	30	14	17.1	284	y
20/30: 66.7%					26/30: 86.7%				

TYPE 5		Rohde & Schwarz K350 Pulse Sequencer DFS		
Trial #	Detection (yes/no)	Chirp Width (MHz)	Subset	Fc
1	y	18	1	5500
2	y	13	1	5500
3	y	5	1	5500
4	y	9	1	5500
5	y	11	1	5500
6	y	6	1	5500
7	y	8	1	5500
8	n	13	1	5500
9	y	14	1	5500
10	y	18	1	5500
11	y	16	2	5497.4
12	y	15	2	5497
13	y	7	2	5493.8
14	y	7	2	5493.8
15	n	6	2	5493.4
16	y	13	2	5496.2
17	y	17	2	5497.8
18	y	17	2	5497.8
19	y	13	2	5496.2
20	y	17	2	5497.8
21	y	6	3	5506.6
22	y	9	3	5505.4
23	y	14	3	5503.4
24	y	12	3	5504.2
25	y	18	3	5501.8
26	y	18	3	5501.8
27	y	11	3	5504.6
28	y	14	3	5503.4
29	y	5	3	5507
30	n	5	3	5507
27/30: 90%				

TYPE 6 S		Rohde & Schwarz K350 Pulse Sequencer DFS
Trial #	Detection (yes/no)	
1	y	
2	y	
3	y	
4	y	
5	n	
6	y	
7	y	
8	y	
9	y	
10	y	
11	y	
12	y	
13	y	
14	y	
15	y	
16	y	
17	y	
18	y	
19	y	
20	y	
21	y	
22	y	
23	y	
24	y	
25	y	
26	y	
27	y	
28	y	
29	y	
30	y	
29/30: 96.7%		

-- End of Test Report --