



427 West 12800 South  
 Draper, UT 84020

## Test Report Certification

<b>FCC ID</b>	SWX-U6EP
<b>ISED ID</b>	6545A-U6EP
<b>Equipment Under Test</b>	U6-Enterprise
<b>Test Report Serial Number</b>	TR6139_02
<b>Date of Test(s)</b>	10, 14, 17, 18, 25 May and 2 June 2021
<b>Report Issue Date</b>	9 June 2021

Test Specification	Applicant
47 CFR FCC Part 15, Subpart E	Ubiquiti Inc. 685 Third Avenue New York, NY 10019 U.S.A.



NVLAP LAB CODE 600241-0

## Certification of Engineering Report

This report has been prepared by Unified Compliance Laboratory (UCL) to document compliance of the device described below with the requirement of Federal Communication Commissions (FCC) Part 15, Subpart E. This report may be reproduced in full. Partial reproduction of this report may only be made with the written consent of the laboratory. The results in this report apply only to the sample tested.

<b>Applicant</b>	Ubiquiti Inc.
<b>Manufacturer</b>	Ubiquiti Inc.
<b>Brand Name</b>	UniFi
<b>Model Number</b>	U6-Enterprise
<b>FCC ID</b>	SWX-U6EP
<b>ISED ID</b>	6545A-U6EP

On this 9<sup>th</sup> day of June 2021, I individually and for Unified Compliance Laboratory certify that the statements made in this engineering report are true, complete, and correct to the best of my knowledge and are made in good faith.

Although NVLAP has accredited the Unified Compliance Laboratory testing facilities, this report must not be used to claim product certification, approval, or endorsement by NVLAP, NIST or any agency of the U.S. federal government.

Unified Compliance Laboratory



Written By: Joseph W. Jackson



Reviewed By: Alex Macon

---

<b>Revision History</b>		
<b>Revision</b>	<b>Description</b>	<b>Date</b>
01	Original Report Release	9 June 2021
02	Amended Sections 3.3.1 and 5.4	11 June 2021

## Table of Contents

1	Client Information.....	5
1.1	Applicant.....	5
1.2	Manufacturer.....	5
2	Equipment Under Test (EUT).....	6
2.1	Identification of EUT.....	6
2.2	Description of EUT.....	6
2.3	EUT and Support Equipment.....	7
2.4	Interface Ports on EUT.....	7
2.5	Operating Environment.....	7
2.6	Operating Modes.....	7
2.7	EUT Exercise Software.....	8
2.8	Block Diagram of Test Configuration.....	8
2.9	Modification Incorporated/Special Accessories on EUT.....	8
2.10	Deviation, Opinions Additional Information or Interpretations from Test Standard.....	8
3	Test Specification, Method and Procedures.....	9
3.1	Test Specification.....	9
3.2	Methods & Procedures.....	9
3.3	FCC Part 15, Subpart E.....	9
3.4	Results.....	9
3.5	Test Location.....	10
4	Test Equipment.....	11
4.1	Conducted Emissions at Mains Ports.....	11
4.2	Direct Connect at the Antenna Port Tests.....	11
4.3	Radiated Emissions.....	12
4.4	Equipment Calibration.....	13
4.5	Measurement Uncertainty.....	13
5	Test Results.....	14
5.1	§15.203 Antenna Requirements.....	14
5.2	Conducted Emissions at Mains Ports Data.....	14
5.3	§15.403(i) 26 dB Emissions Bandwidth.....	16
5.4	§15.403(a)(3) Maximum Average Output Power.....	17
5.5	§15.407(b)(7) Spurious Emissions.....	18
5.6	§15.407(a) Maximum Power Spectral Density.....	26
5.7	§15.407(d) Contention Based Protocol.....	27

# 1 Client Information

## 1.1 Applicant

<b>Company</b>	Ubiquiti Inc. 685 Third Avenue New York, NY 10017 U.S.A.
<b>Contact Name</b>	Mark Feil
<b>Title</b>	Compliance Manager

## 1.2 Manufacturer

<b>Company</b>	Ubiquiti Inc. 685 Third Avenue New York, NY 10017 U.S.A.
<b>Contact Name</b>	Mark Feil
<b>Title</b>	Compliance Manager

## 2 Equipment Under Test (EUT)

### 2.1 Identification of EUT

<b>Brand Name</b>	UniFi
<b>Model Number</b>	U6-Enterprise
<b>Serial Number</b>	68D79A1F0D5A
<b>Dimensions (cm)</b>	22.0 x 22.0 x 4.8

### 2.2 Description of EUT

The U6-Enterprise is a four-stream WiFi 6 access point that provides up to 2.4 Gbps aggregate radio rate with 2.4 GHz (2x2), 5 GHz (4x4) and 6 GHz (4x4) radios. The U6-Enterprise is designed for indoor use. The U6-Enterprise has an Ethernet port for data transfer and is powered by an 803.2at PoE power adapter. The U6-Enterprise has a Bluetooth management radio to achieve setup and operation.

The table below show the channels used within the different modulation bandwidths.

<b>Band</b>	<b>Modulation Bandwidth</b>	<b>Frequency (MHz)</b>	<b>Maximum Power Setting</b>
UNII-7	ax (HEW20)	6535, 6555, 6575, 6595, 6615, 6635, 6655, 6675	TP23
		6695, 6715, 6735, 6755, 6775, 6795, 6815, 6835, 6855	TP22
		6875	TP25
	ax (HEW40)	6525, 6565, 6605, 6645,	TP29
		6685, 6725, 6765, 6805, 6845	TP27
		6885	TP30
	ax (HEW80)	6545, 6625	TP35
		6705, 6785	TP34
		6865	TP36
	ax (HEW160)	6505, 6665	TP40
		6825	TP42

This report covers the circuitry of the device subject to FCC Part 15, Subpart E. The circuitry of the device subject to FCC Part 15 Subpart B was found to be compliant and is covered under a separate Unified Compliance Laboratory test report.

## 2.3 EUT and Support Equipment

The EUT and support equipment used during the test are listed below.

<b>Brand Name Model Number Serial Number</b>	<b>Description</b>	<b>Name of Interface Ports / Interface Cables</b>
BN: UniFi MN: U6-Enterprise SN: 68D79A1F0D5A	WiFi Access Point	See Section 2.4
BN: Ubiquiti MN: UPOE-at SN: N/A	PoE Power Adapter	Shielded or Un-Shielded Cat 5e cable (Note 2)
BN: Dell MN: XPS 13 SN: N/A	Laptop Personal Computer	Shielded or Un-Shielded Cat 5e cable (Note 2)

Notes: (1) EUT

(2) Interface port connected to EUT (See Section 2.4)

The support equipment listed above was not modified in order to achieve compliance with this standard.

## 2.4 Interface Ports on EUT

<b>Name of Ports</b>	<b>No. of Ports Fitted to EUT</b>	<b>Cable Description/Length</b>
PoE	1	Shielded or Un-Shielded Cat 5e Cable/> 3 meters
Data	1	Shielded or Un-Shielded Cat 5e Cable/> 3 Meters

## 2.5 Operating Environment

<b>Power Supply</b>	120 Volts ac to 48 Volts PoE Power
<b>AC Mains Frequency</b>	60 Hz
<b>Temperature</b>	21.3 – 21.8 °C
<b>Humidity</b>	22.0 – 24.7 %
<b>Barometric Pressure</b>	1019 mBar

## 2.6 Operating Modes

The U6-Enterprise was tested using test software in order to enable to constant transmission of over 98% All emission modes of 802.11ax were investigated. All measurements are reported with the worst-case mode (802.11ax) unless otherwise stated.

## 2.7 EUT Exercise Software

EUT firmware version 1.0 was used to operate the transmitter using a constant transmit mode.

## 2.8 Block Diagram of Test Configuration

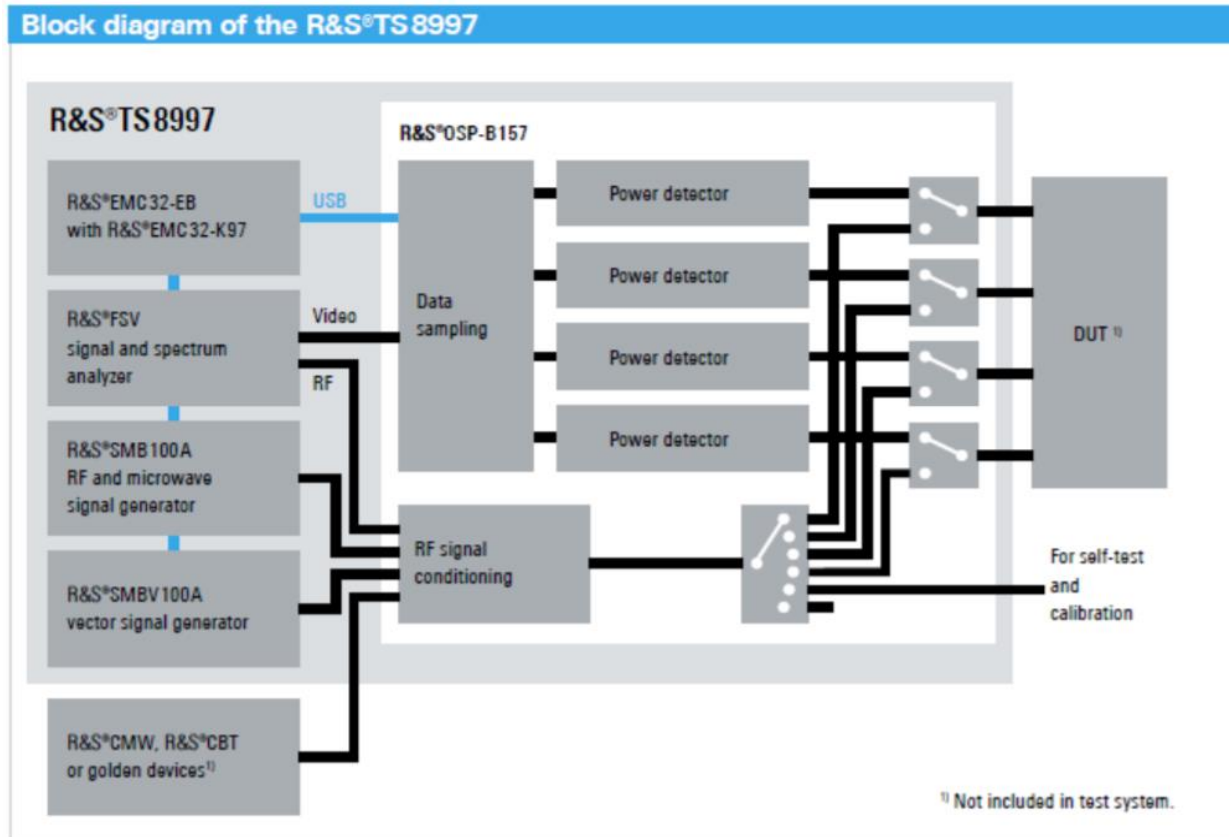

Diagram 1: Test Configuration Block Diagram

## 2.9 Modification Incorporated/Special Accessories on EUT

There were no modifications made to the EUT during testing to comply with the specification.

## 2.10 Deviation, Opinions Additional Information or Interpretations from Test Standard

There were no deviations, opinions, additional information or interpretations from the test specification.



## 3 Test Specification, Method and Procedures

### 3.1 Test Specification

<b>Title</b>	47 CFR FCC Part 15, Subpart E, Section 15.407 Limits and methods of measurement of radio interference characteristics of Unlicensed National Information Infrastructure Devices
<b>Purpose of Test</b>	The tests were performed to demonstrate initial compliance

### 3.2 Methods & Procedures

#### 3.2.1 47 CFR FCC Part 15 Section 15.407

See test standard for details.

### 3.3 FCC Part 15, Subpart E

#### 3.3.1 Summary of Tests

FCC Section	ISED Section	Environmental Phenomena	Frequency Range (MHZ)	Result
15.203	N/A	Antenna requirements	Structural Requirement	Compliant
15.207	RSS-Gen	Conducted Disturbance at Mains Port	0.15 to 30	Compliant
15.407(a)	RSS-247 §6.2.2, §6.2.3	Bandwidth Requirement	6535 to 6865	Compliant
15.407(a)	RSS-247 §6.2.2, §6.2.3	Peak Output Power	6535 to 6865	Compliant
15.407(f)	RSS-247 §6.2.2, §6.2.3	Antenna Conducted Spurious Emissions	0.009 to 40000	N/A
15.407(a)	RSS-247 §6.2.2, §6.2.3	Radiated Spurious Emissions	0.009 to 40000	Compliant
15.407(a)	RSS-247 §6.2.2, §6.2.3	Peak Power Spectral Density	6535 to 6865	Compliant
15.407(d)	RSS-247 §6.2.2, §6.2.3	Contention Based Protocol	6535 to 6865	Compliant
The testing was performed according to the procedures in ANSI C63.10-2013, KDB 789033 and 47 CFR Part 15. Where applicable, KDB 662911 was followed to sum required measurements.				

### 3.4 Results

In the configuration tested, the EUT complied with the requirements of the specification.

### **3.5 Test Location**

Testing was performed at the Unified Compliance Laboratory 3-Meter and 10-Meter chambers located at 427 West 12800 South, Draper, UT 84020. Unified Compliance Laboratory is accredited by National Voluntary Laboratory Accreditation Program (NVLAP); NVLAP Code 600241-0 which is effective until 30 June 2021. This site has also been registered with Innovations, Science and Economic Development (ISED) department as was accepted under Appendix B, Phase 1 procedures of the APEC Tel MRA for Canadian recognition. ISED No.: 25346, effective until June 30, 2021. Unified Compliance Laboratory has been assigned Conformity Assessment Number US0223 by ISED.

## 4 Test Equipment

### 4.1 Conducted Emissions at Mains Ports

Type of Equipment	Manufacturer	Model Number	Asset Number	Date of Last Calibration	Due Date of Calibration
EMI Receiver	AFJ	FFT3010	UCL-2500	9/18/2020	9/17/2021
LISN	AFJ	LS16C/10	UCL-2512	5/26/2020	5/26/2022
Cat6 ISN	Teseq	ISN T8-Cat6	UCL-2971	5/18/2020	5/18/2022
ISN	Teseq	ISN T800	UCL-2974	6/1/2020	6/1/2021
LISN	Com-Power	LIN-120C	UCL-2612	5/19/2021	5/19/2022
AC Power Source	Laplace Instruments	AC1000A	UCL-2857	N/A	N/A
Test Software	UCL	Revision 1	UCL-3107	N/A	N/A

Table 1: List of equipment used for Conducted Emissions Testing at Mains Port

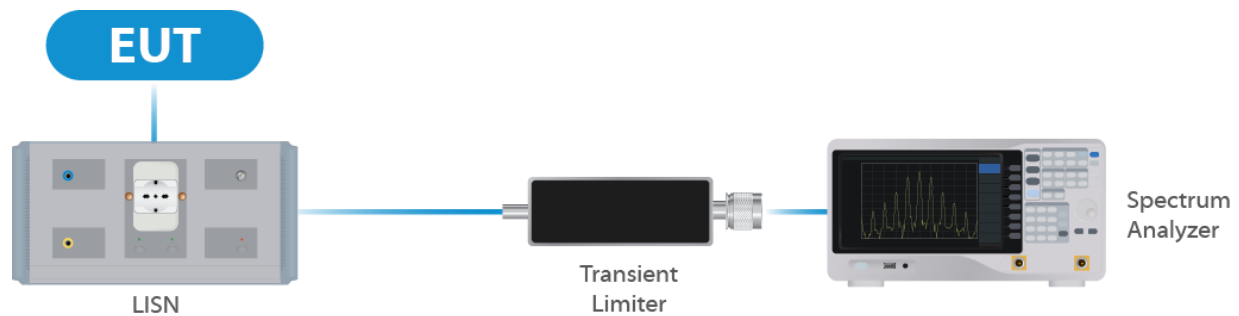

Figure 1: Conducted Emissions Test

### 4.2 Direct Connect at the Antenna Port Tests

Type of Equipment	Manufacturer	Model Number	Asset Number	Date of Last Calibration	Due Date of Calibration
Spectrum Analyzer	R&S	FSV40	UCL-2861	8/24/2020	8/24/2021
Signal Generator	R&S	SMB100A	UCL-2864	N/A	N/A
Vector Signal Generator	R&S	SMBV100A	UCL-2873	N/A	N/A
Switch Extension	R&S	OSP-B157WX	UCL-2867	9/8/2020	9/8/2021
Switch Extension	R&S	OSP-150W	UCL-2870	3/3/2021	3/3/2022

Table 2: List of equipment used for Direct Connect at the Antenna Port

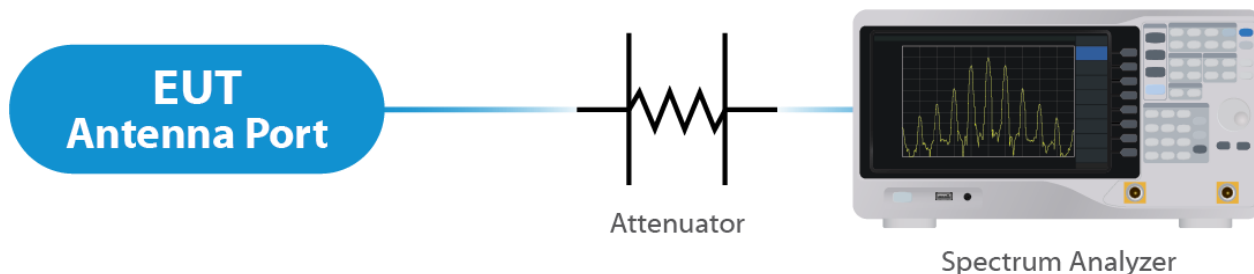

Figure 2: Direct Connect at the Antenna Port Test

### 4.3 Radiated Emissions

Type of Equipment	Manufacturer	Model Number	Asset Number	Date of Last Calibration	Due Date of Calibration
EMI Receiver	Keysight	N9038A	UCL-2778	6/1/2020	8/1/2021
Pre-Amplifier 9 kHz – 1 GHz	Sonoma Instruments	310N	UCL-2889	9/10/2020	9/10/2021
Double Ridge Horn Antenna	Scwarzbeck	BBHA 9120D	UCL-3065	7/8/2020	7/8/2021
Log Periodic	Scwarzbeck	STLP 9129	UCL-3068	11/16/2020	11/16/2021
15 - 40 GHz Horn Antenna	Scwarzbeck	BBHA 9170	UCL-2487	5/21/2020	5/21/2022
1 – 18 GHz Amplifier	Com-Power	PAM 118A	UCL-3833	9/29/2020	9/29/2021
Test Software	UCL	Revision 1	UCL-3108	N/A	N/A

Table 3:List of equipment used for Radiated Emissions

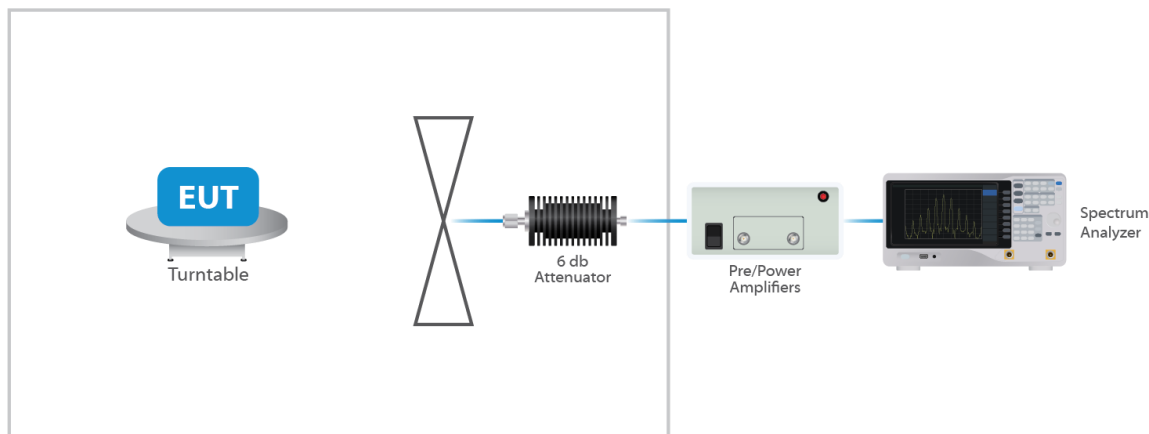

Figure 3: Radiated Emissions Test

## 4.4 Equipment Calibration

All applicable equipment is calibrated using either an independent calibration laboratory or Unified Compliance Laboratory personnel at intervals defined in ANSI C63.4:2014 following outlined calibration procedures. All measurement instrumentation is traceable to the National Institute of Standards and Technology (NIST). Supporting documentation relative to traceability is on file and is available for examination upon request.

## 4.5 Measurement Uncertainty

Test	Uncertainty ( $\pm$ dB)	Confidence (%)
Conducted Emissions	1.44	95
Radiated Emissions (9 kHz to 30 MHz)	2.50	95
Radiated Emissions (30 MHz to 1 GHz)	4.38	95
Radiated Emissions (1 GHz to 18 GHz)	4.37	95
Radiated Emissions (18 GHz to 40 GHz)	3.93	95
<b>Direct Connect Tests</b>	<b>K Factor</b>	<b>Value</b>
Emissions Bandwidth	2	2.0%
Output Power	2	1.0 dB
Peak Power Spectral Density	2	1.3 dB
Band Edge	2	0.8 dB
Transmitter Spurious Emissions	2	1.8 dB

## 5 Test Results

### 5.1 §15.203 Antenna Requirements

The EUT uses an integral antenna. The Maximum gain of the antenna is 6.0 dBi. The antenna is not user replaceable.

#### Results

The EUT complied with the specification

### 5.2 Conducted Emissions at Mains Ports Data

#### 5.2.1 Line

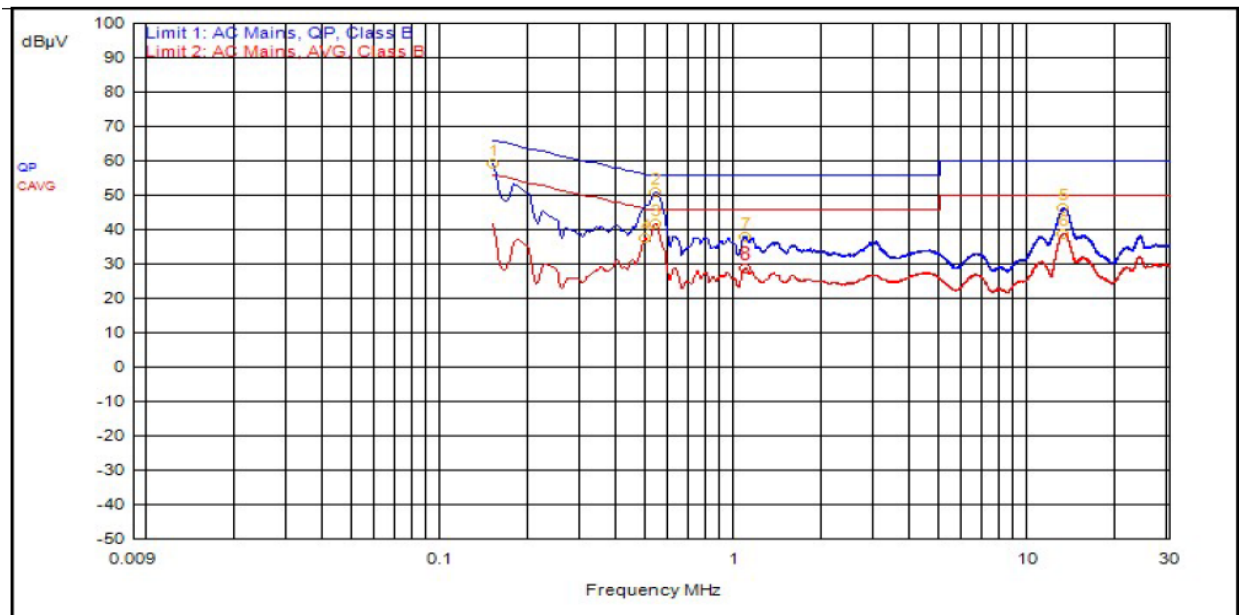

ID	Frequency	Probe	Cable	Atten.	Detector	Meter Read	Meas Level	Limit 1	Limit 1 Dist.	Limit 2	Limit 2 Dist.
2	534,000kHz	12.4			QPeak	38.3	50.7	56.0	-5.3		
1	150,000kHz	12.4			QPeak	46.8	59.2	66.0	-6.8		
5	13.041MHz	12.4			QPeak	33.7	46.2	60.0	-13.8		
7	1.083MHz	12.4			QPeak	25.4	37.8	56.0	-18.2		
3	537,000kHz	12.4			C_AVG	29.2	41.6			46.0	-4.4
4	495,000kHz	12.4			C_AVG	25.1	37.5			46.1	-8.6
6	13.041MHz	12.4			C_AVG	26.4	38.8			50.0	-11.2
8	1.083MHz	12.4			C_AVG	16.3	28.7			46.0	-17.3

## 5.2.2 Neutral

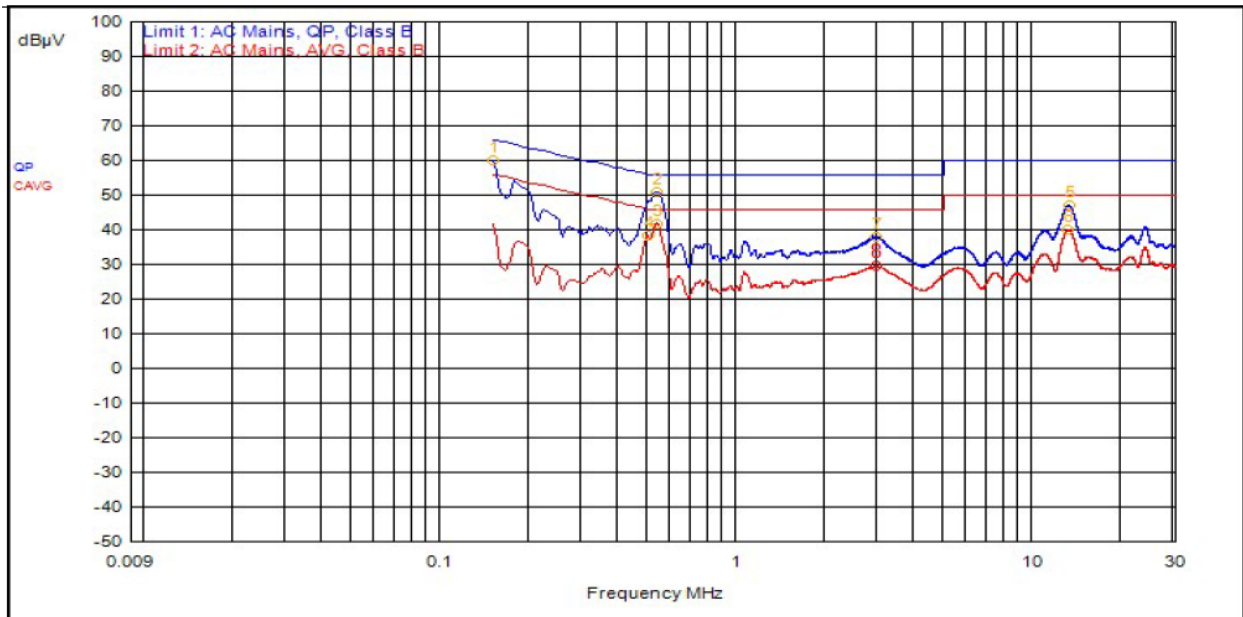

ID	Frequency	Probe	Cable	Atten.	Detector	Meter Read	Meas Level	Limit 1	Limit 1 Dist.	Limit 2	Limit 2 Dist.
2	531,000kHz	12.4			QPeak	38.4	50.8	56.0	-5.2		
1	150,000kHz	12.4			QPeak	47.5	59.9	66.0	-6.1		
5	13.080MHz	12.4			QPeak	34.5	46.9	60.0	-13.1		
7	2.940MHz	12.3			QPeak	25.7	38.0	56.0	-18.0		
3	531,000kHz	12.4			C_AVG	29.4	41.8			46.0	-4.2
4	498,000kHz	12.4			C_AVG	25.9	38.3			46.0	-7.8
6	12.963MHz	12.4			C_AVG	27.5	39.9			50.0	-10.1
8	2.928MHz	12.3			C_AVG	17.2	29.5			46.0	-16.5

### Result

The EUT complied with the specification limit.

### 5.3 §15.403(i) 26 dB Emissions Bandwidth

Nominal BW (MHz)	Frequency (MHz)	99% Bandwidth (MHz)	26 dB Bandwidth (MHz)
20	6535	17.8	21.6
20	6695	17.8	21.3
20	6875	17.9	21.9
40	6525	36.3	38.9
40	6685	36.3	39.5
40	6885	36.3	39.2
80	6545	76.0	82.5
80	6705	75.5	83.5
80	6865	75.5	82.0
160	6505	156.0	165.0
160	6665	154.0	164.0
160	6825	156.0	164.0

#### Result

The 26 dB bandwidths are reported for information purposes. Please see Annex for all bandwidth measurements.



## 5.4 §15.403(a)(3) Maximum Average Output Power

The maximum average RF conducted output power measured for this device was 23.62 dBm or 230.14 mW. The limit is 30 dBm EIRP, or 1 Watt EIRP. The antenna has a gain of 6.0 dBi.

Modulation (BW)	Frequency (MHz)	Data Rate	TP Setting	Conducted Output Power *	Output Power EIRP	Measured PSD
HE20	6535	Mcs0	23	14.55	20.55	-1.23
HE20	6695	Mcs0	22	14.44	20.44	-1.49
HE20	6875	Mcs0	25	14.82	20.82	-1.00
HE40	6525	Mcs0	29	17.94	23.94	-1.20
HE40	6685	Mcs0	27	17.48	23.48	-1.32
HE40	6885	Mcs0	30	17.88	23.88	-1.13
HE80	6545	Mcs0	35	20.79	26.79	-1.19
HE80	6705	Mcs0	34	20.74	26.74	-1.47
HE80	6865	Mcs0	36	20.56	26.56	-1.46
HE160	6505	Mcs0	40	23.38	29.38	-1.25
HE160	6665	Mcs0	40	23.62	29.62	-1.12
HE160	6825	Mcs0	42	23.54	29.54	-1.14

### Result

In the configuration tested, the maximum average RF outpower was less than 1 watt EIRP; therefore, the EUT complied with the requirements of the specification (see spectrum analyzer plots in attached Annex).

\* Gated EIRP shown in the Annex is the conducted measurement

## 5.5 §15.407(b)(7) Spurious Emissions

### 5.5.1 Conducted Spurious Emissions

The frequency range from the lowest frequency generated or used in the device to the tenth harmonic of the highest fundamental frequency was investigated to measure any antenna-conducted emissions. The graphs show the measurement data from spurious emissions noted across the frequency range when transmitting at the lowest frequency, middle frequency and upper frequency. Shown below are plots with the EUT turned to the upper and lower channels with the antenna gain of 6.0 dBi accounted for. These demonstrate compliance with the provisions of this section at the band edges.

The emissions must remain below -27 dBm EIRP.

#### Result

Conducted spurious emissions were attenuated below the limit; therefore, the EUT complies with the specification.

### 5.5.2 Radiated Spurious Emissions in the Restricted Bands of § 15.205

The EUT uses various power settings based on the channel in use. In order to reduce test time, the radiated spurious emissions at the lowest, middle, and highest channel were measured at the maximum power of TP42.

#### Result

All emissions in the restricted bands of § 15.205 met the limits specified in § 15.209; therefore, the EUT complies with the specification. See Annex for Conducted Band edge plots.

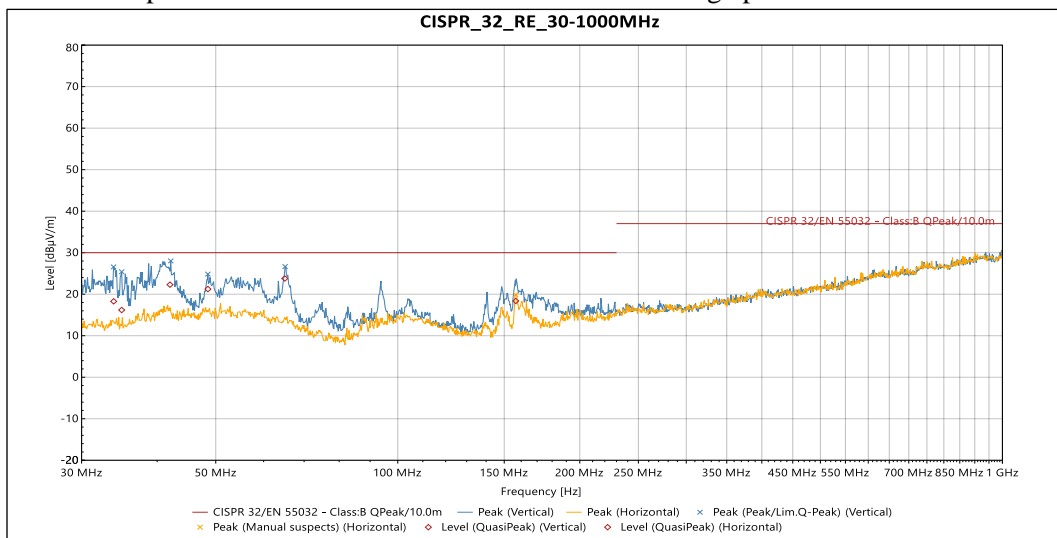

#### Vertical

Source	Frequency	Level (dBµV/m)	Limit (dBµV/m)	Margin	Azimuth (°)	Height	Pol.	Correction (dB)
QuasiPeak	33.896 MHz	18.279	30	-11.721	81	1.106	Vertical	-15.184
QuasiPeak	34.945 MHz	16.188	30	-13.812	319	1.946	Vertical	-14.833
QuasiPeak	42.009 MHz	22.297	30	-7.703	73	2.164	Vertical	-12.832
QuasiPeak	48.534 MHz	21.24	30	-8.76	20	2.62	Vertical	-12.359
QuasiPeak	65.031 MHz	23.786	30	-6.214	108	2.835	Vertical	-14.684

**Horizontal**

Source	Frequency	Level (dB $\mu$ V/m)	Limit (dB $\mu$ V/m)	Margin	Azimuth (°)	Height	Pol.	Correction (dB)
QuasiPeak	156.72 MHz	18.377	30	-11.623	235	3.995	Horizontal	-17.354

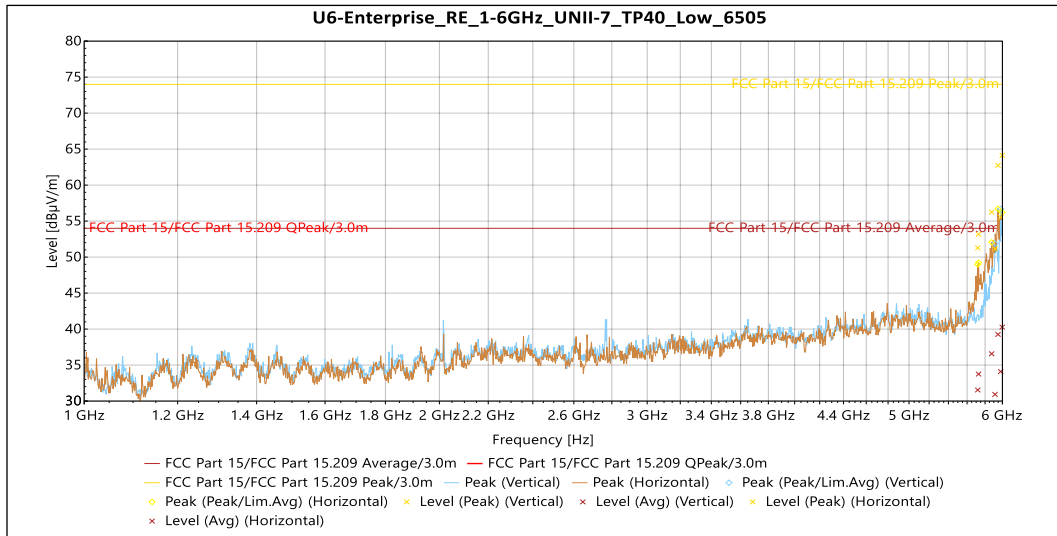
**Table 4: Radiated Emissions 30 – 1000 MHz**

Vertical – No significant emissions were observed in this orientation of the antenna from 1 – 6 GHz

Horizontal – No significant emissions were observed in this orientation of the antenna from 1 – 6 GHz

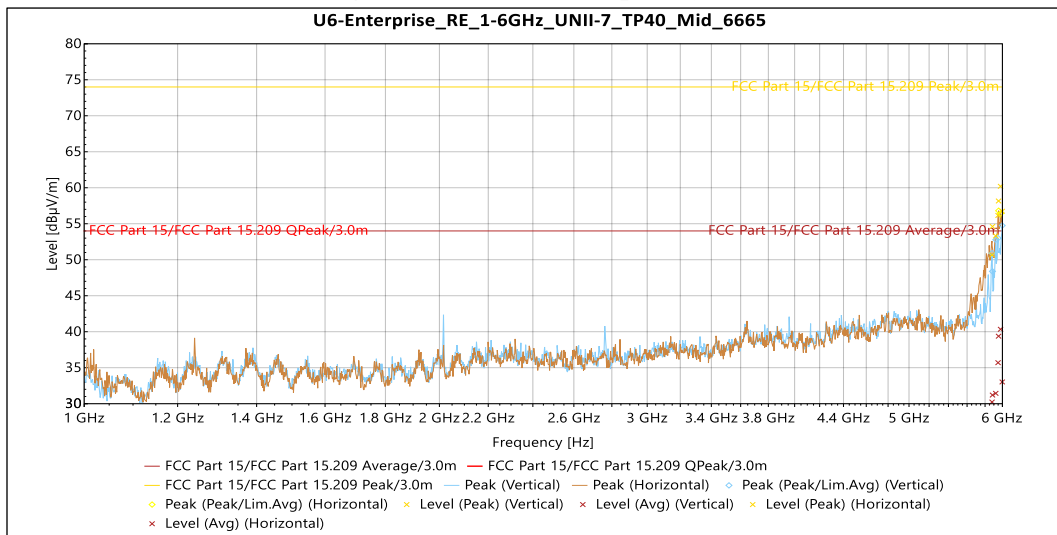
**Table 5: Transmitting on the Lowest Frequency 6505 MHz – 1 – 6 GHz**

Vertical – No significant emissions were observed in this orientation of the antenna from 1 – 6 GHz

Horizontal – No significant emissions were observed in this orientation of the antenna from 1 – 6 GHz

**Table 6: Transmitting on the Middle Frequency 6665 MHz – 1 – 6 GHz**

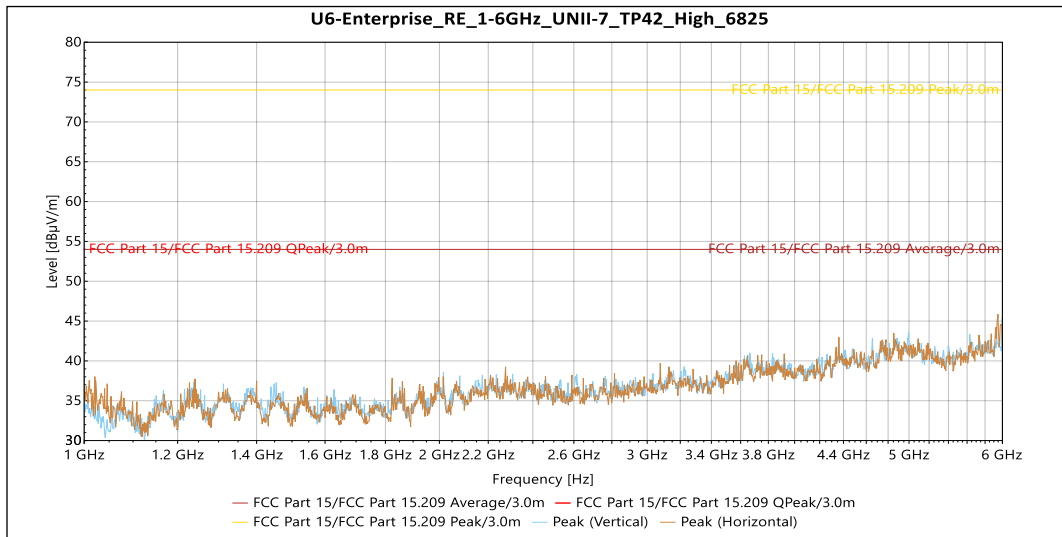

Vertical – No significant emissions were observed in this orientation of the antenna from 1 – 6 GHz  
 Horizontal – No significant emissions were observed in this orientation of the antenna from 1 – 6 GHz

**Table 7: Transmitting on the Highest Frequency 6825 MHz – 1 – 6 GHz**

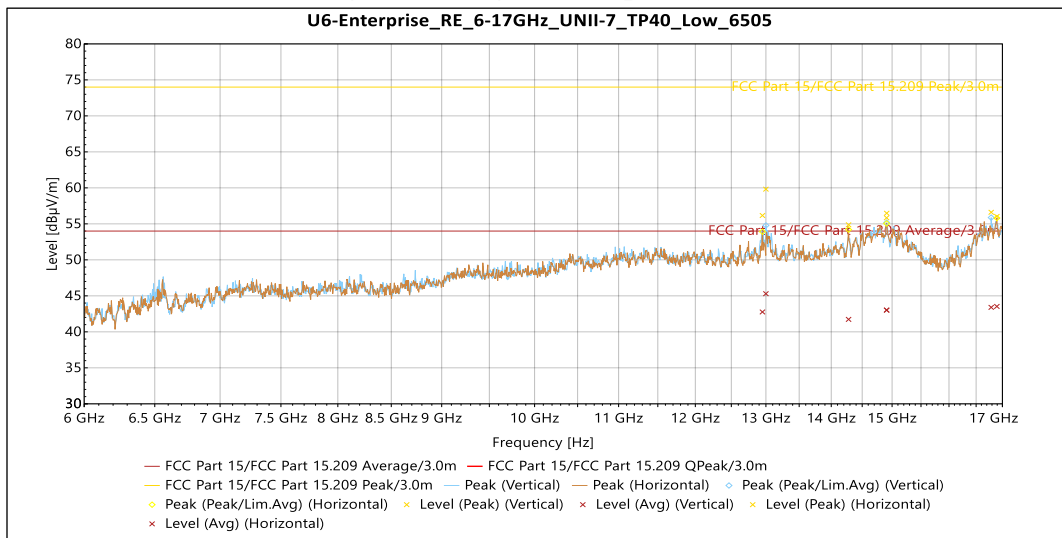

**Vertical**

Source	Frequency	Level (dBµV/m)	Limit (dBµV/m)	Margin (dB)	Azimuth (°)	Height (m)	Pol.	Correction (dB)
Peak	13 GHz	59.815	74	-14.185	28	2.812	Vertical	5.607
Peak	14.909 GHz	56.481	74	-17.519	181	1.83	Vertical	10.045
Peak	16.785 GHz	56.609	74	-17.391	99	2.654	Vertical	11.587

Source	Frequency	Level (dBµV/m)	Limit (dBµV/m)	Margin (dB)	Azimuth (°)	Height (m)	Pol.	Correction (dB)
Avg	13 GHz	45.296	54	-8.704	28	2.812	Vertical	5.607
Avg	14.909 GHz	43.013	54	-10.987	181	1.83	Vertical	10.045
Avg	16.785 GHz	43.403	54	-10.597	99	2.654	Vertical	11.587

**Horizontal**

Source	Frequency	Level (dBµV/m)	Limit (dBµV/m)	Margin (dB)	Azimuth (°)	Height (m)	Pol.	Correction (dB)
Peak	12.949 GHz	56.157	74	-17.843	29	1.5	Horizontal	6.079
Peak	14.278 GHz	54.871	74	-19.129	111	4	Horizontal	8.151
Peak	14.907 GHz	55.835	74	-18.165	3	1.5	Horizontal	10.092
Peak	16.893 GHz	56.031	74	-17.969	42	1.704	Horizontal	11.968

Source	Frequency	Level (dBµV/m)	Limit (dBµV/m)	Margin (dB)	Azimuth (°)	Height (m)	Pol.	Correction (dB)
Avg	12.949 GHz	42.756	54	-11.244	29	1.5	Horizontal	6.079
Avg	14.278 GHz	41.728	54	-12.272	111	4	Horizontal	8.151
Avg	14.907 GHz	43.028	54	-10.972	3	1.5	Horizontal	10.092
Avg	16.893 GHz	43.525	54	-10.475	42	1.704	Horizontal	11.968

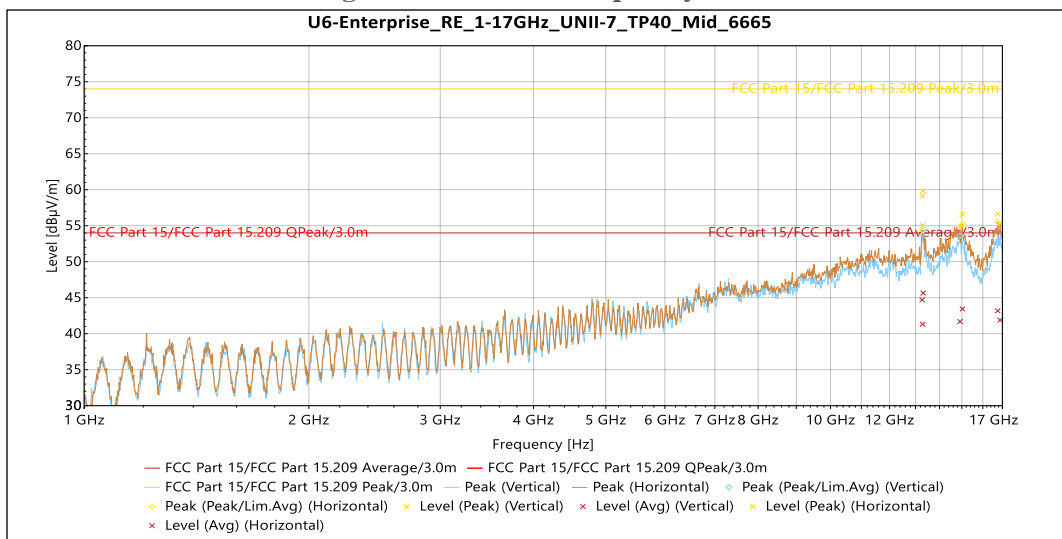
**Table 8: Transmitting on the Lowest Frequency 6505 MHz – 6 – 17 GHz**

**Vertical**

Source	Frequency	Level (dBµV/m)	Limit (dBµV/m)	Margin (dB)	Azimuth (°)	Height (m)	Pol.	Correction (dB)
Peak	13.27 GHz	59.154	74	-14.846	21	2.29	Vertical	6.849
Peak	13.31 GHz	59.845	74	-14.155	27	4	Vertical	5.475
Peak	14.918 GHz	54.842	74	-19.158	25	1.821	Vertical	9.834
Peak	16.88 GHz	55.266	74	-18.734	205	2.15	Vertical	12.138

Source	Frequency	Level (dBµV/m)	Limit (dBµV/m)	Margin (dB)	Azimuth (°)	Height (m)	Pol.	Correction (dB)
Avg	13.27 GHz	44.711	54	-9.289	21	2.29	Vertical	6.849
Avg	13.31 GHz	45.641	54	-8.359	27	4	Vertical	5.475
Avg	14.918 GHz	41.686	54	-12.314	25	1.821	Vertical	9.834
Avg	16.88 GHz	41.894	54	-12.106	205	2.15	Vertical	12.138

**Horizontal**

Source	Frequency	Level (dBµV/m)	Limit (dBµV/m)	Margin (dB)	Azimuth (°)	Height (m)	Pol.	Correction (dB)
Peak	13.288 GHz	55.02	74	-18.98	343	1.5	Horizontal	6.037
Peak	15.025 GHz	56.578	74	-17.422	37	2.65	Horizontal	10.399
Peak	16.754 GHz	56.627	74	-17.373	304	3.157	Horizontal	11.214

Source	Frequency	Level (dBµV/m)	Limit (dBµV/m)	Margin (dB)	Azimuth (°)	Height (m)	Pol.	Correction (dB)
Avg	13.288 GHz	41.314	54	-12.686	343	1.5	Horizontal	6.037
Avg	15.025 GHz	43.436	54	-10.564	37	2.65	Horizontal	10.399

Source	Frequency	Level (dB $\mu$ V/m)	Limit (dB $\mu$ V/m)	Margin (dB)	Azimuth (°)	Height (m)	Pol.	Correction (dB)
Avg	16.754 GHz	43.176	54	-10.824	304	3.157	Horizontal	11.214

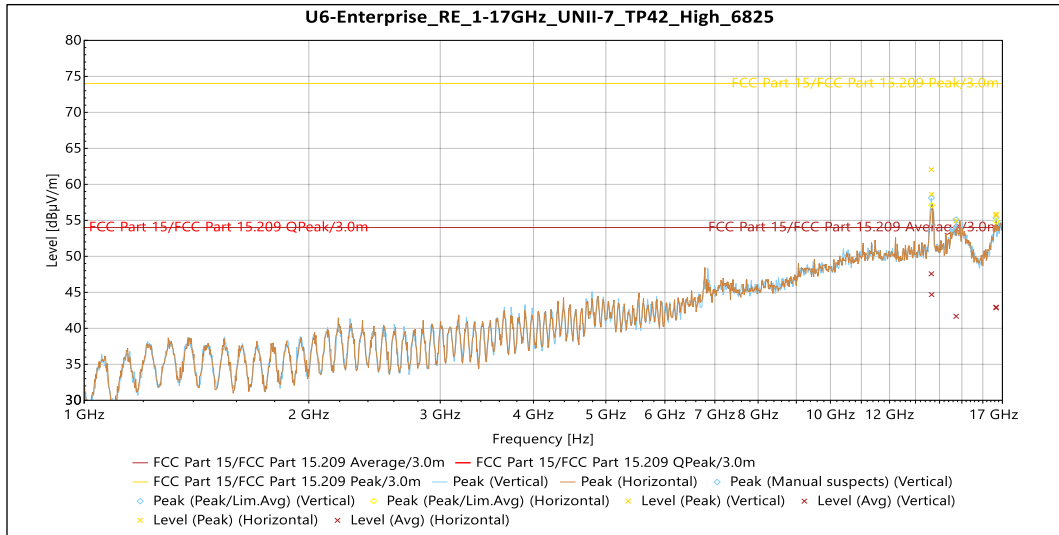
**Table 9: Transmitting on the Middle Frequency 6665 MHz – 6 – 17 GHz**

**Vertica**

Source	Frequency	Level (dB $\mu$ V/m)	Limit (dB $\mu$ V/m)	Margin (dB)	Azimuth (°)	Height (m)	Pol.	Correction (dB)
Peak	13.654 GHz	62.052	74	-11.948	347	2.335	Vertical	5.972
Peak	14.739 GHz	54.934	74	-19.066	19	3.144	Vertical	8.397
Peak	16.671 GHz	55.659	74	-18.341	228	1.84	Vertical	11.407

Source	Frequency	Level (dB $\mu$ V/m)	Limit (dB $\mu$ V/m)	Margin (dB)	Azimuth (°)	Height (m)	Pol.	Correction (dB)
Avg	13.654 GHz	47.569	54	-6.431	347	2.335	Vertical	5.972
Avg	14.739 GHz	41.668	54	-12.332	19	3.144	Vertical	8.397
Avg	16.671 GHz	42.843	54	-11.157	228	1.84	Vertical	11.407

**Horizontal**

Source	Frequency	Level (dB $\mu$ V/m)	Limit (dB $\mu$ V/m)	Margin (dB)	Azimuth (°)	Height (m)	Pol.	Correction (dB)
Peak	13.663 GHz	58.627	74	-15.373	80	3.805	Horizontal	5.71
Peak	16.673 GHz	55.857	74	-18.143	283	3.312	Horizontal	11.444

Source	Frequency	Level (dB $\mu$ V/m)	Limit (dB $\mu$ V/m)	Margin (dB)	Azimuth (°)	Height (m)	Pol.	Correction (dB)
Avg	13.663 GHz	44.679	54	-9.321	80	3.805	Horizontal	5.71
Avg	16.673 GHz	42.935	54	-11.065	283	3.312	Horizontal	11.444

**Table 10: Transmitting on the Highest Frequency 6825 MHz – 6 – 17 GHz**

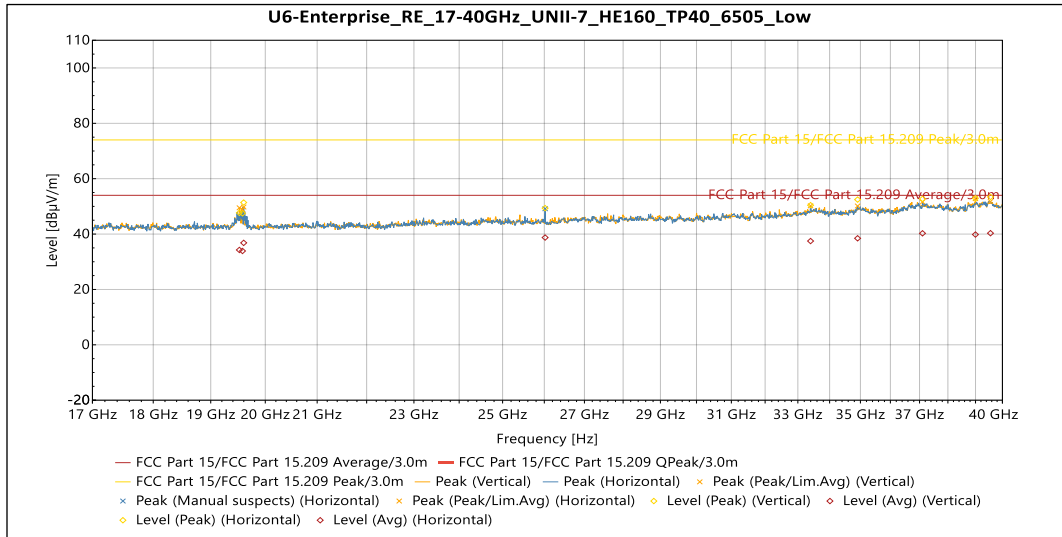

### Vertical

Source	Frequency	Level (dBµV/m)	Limit (dBµV/m)	Margin (dB)	Azimuth (°)	Pol.	Correction (dB)
Peak	19.519 GHz	47.661	74	-26.339	321	Vertical	-6.187
Peak	19.576 GHz	47.494	74	-26.506	38	Vertical	-5.959
Peak	37.104 GHz	52.702	74	-21.298	201	Vertical	1.409
Peak	38.997 GHz	52.926	74	-21.074	164	Vertical	3.051

Source	Frequency	Level (dBµV/m)	Limit (dBµV/m)	Margin (dB)	Azimuth (°)	Pol.	Correction (dB)
Avg	19.519 GHz	34.26	54	-19.74	321	Vertical	-6.187
Avg	19.576 GHz	33.894	54	-20.106	38	Vertical	-5.959
Avg	37.104 GHz	40.269	54	-13.731	201	Vertical	1.409
Avg	38.997 GHz	39.827	54	-14.173	164	Vertical	3.051

### Horizontal

Source	Frequency	Level (dBµV/m)	Limit (dBµV/m)	Margin (dB)	Azimuth (°)	Pol.	Correction (dB)
Peak	19.598 GHz	51.39	74	-22.61	336	Horizontal	-6.16
Peak	26.02 GHz	49.371	74	-24.629	353	Horizontal	-5.704
Peak	33.397 GHz	50.428	74	-23.572	117	Horizontal	1.112
Peak	34.907 GHz	52.457	74	-21.543	148	Horizontal	0.902
Peak	39.553 GHz	53.411	74	-20.589	98	Horizontal	3.281

Source	Frequency	Level (dBµV/m)	Limit (dBµV/m)	Margin (dB)	Azimuth (°)	Pol.	Correction (dB)
Avg	19.598 GHz	36.817	54	-17.183	336	Horizontal	-6.16
Avg	26.02 GHz	38.744	54	-15.256	353	Horizontal	-5.704
Avg	33.397 GHz	37.476	54	-16.524	117	Horizontal	1.112
Avg	34.907 GHz	38.466	54	-15.534	148	Horizontal	0.902
Avg	39.553 GHz	40.313	54	-13.687	98	Horizontal	3.281

**Table 11: Transmitting on the Lowest Frequency 6505 MHz – 17 – 40 GHz**

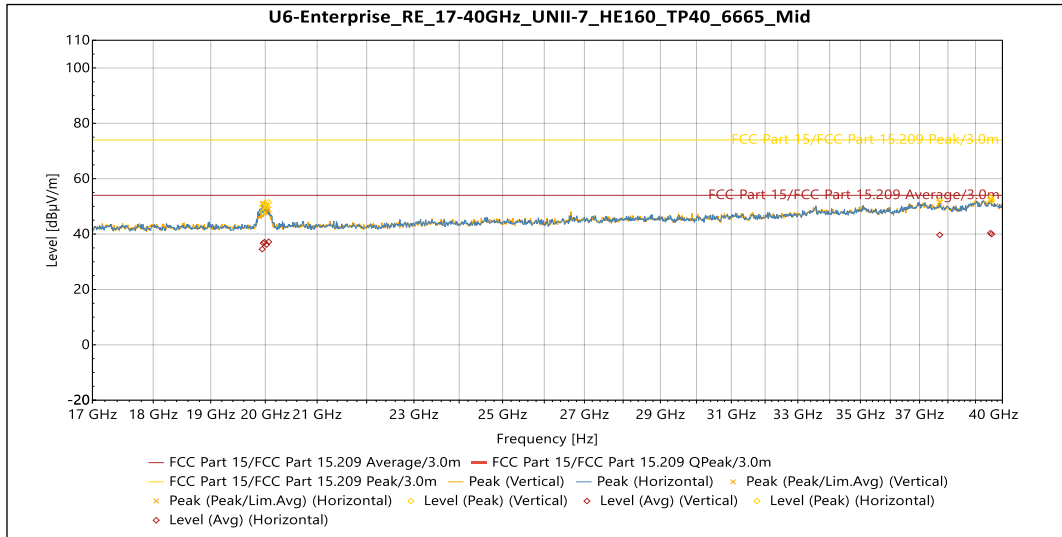
**Vertical**

Source	Frequency	Level (dBµV/m)	Limit (dBµV/m)	Margin (dB)	Azimuth (°)	Pol.	Correction (dB)
Peak	19.985 GHz	51.118	74	-22.882	23	Vertical	-5.938
Peak	20.024 GHz	50.014	74	-23.986	2	Vertical	-5.978
Peak	20.064 GHz	51.484	74	-22.516	1	Vertical	-5.937
Peak	39.6 GHz	52.243	74	-21.757	187	Vertical	3.364

Source	Frequency	Level (dBµV/m)	Limit (dBµV/m)	Margin (dB)	Azimuth (°)	Pol.	Correction (dB)
Avg	19.985 GHz	37.088	54	-16.912	23	Vertical	-5.938
Avg	20.024 GHz	36.186	54	-17.814	2	Vertical	-5.978
Avg	20.064 GHz	37.227	54	-16.773	1	Vertical	-5.937
Avg	39.6 GHz	39.961	54	-14.039	187	Vertical	3.364

**Horizontal**

Source	Frequency	Level (dBµV/m)	Limit (dBµV/m)	Margin (dB)	Azimuth (°)	Pol.	Correction (dB)
Peak	19.943 GHz	47.924	74	-26.076	36	Horizontal	-6.187
Peak	19.962 GHz	50.026	74	-23.974	35	Horizontal	-6.105
Peak	37.709 GHz	52.163	74	-21.837	74	Horizontal	1.213
Peak	39.554 GHz	53.245	74	-20.755	260	Horizontal	3.287

Source	Frequency	Level (dBµV/m)	Limit (dBµV/m)	Margin (dB)	Azimuth (°)	Pol.	Correction (dB)
Avg	19.943 GHz	34.554	54	-19.446	36	Horizontal	-6.187
Avg	19.962 GHz	36.723	54	-17.277	35	Horizontal	-6.105
Avg	37.709 GHz	39.69	54	-14.31	74	Horizontal	1.213
Avg	39.554 GHz	40.359	54	-13.641	260	Horizontal	3.287

**Table 12: Transmitting on the Middle Frequency 6665 MHz – 17 – 40 GHz**

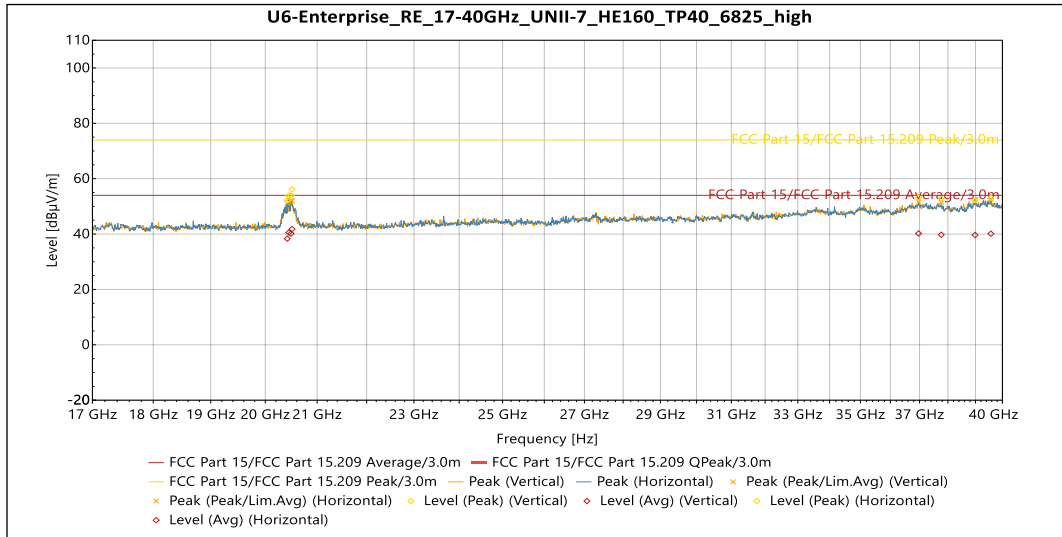

**Vertical**

Source	Frequency	Level (dBµV/m)	Limit (dBµV/m)	Margin (dB)	Azimuth (°)	Pol.	Correction (dB)
Peak	20.418 GHz	52.194	74	-21.806	359	Vertical	-5.765
Peak	20.509 GHz	56.106	74	-17.894	358	Vertical	-5.51
Peak	37.765 GHz	52.779	74	-21.221	133	Vertical	1.295
Peak	38.984 GHz	52.258	74	-21.742	281	Vertical	3.044

Source	Frequency	Level (dBµV/m)	Limit (dBµV/m)	Margin (dB)	Azimuth (°)	Pol.	Correction (dB)
Avg	20.418 GHz	38.335	54	-15.665	359	Vertical	-5.765
Avg	20.509 GHz	41.802	54	-12.198	358	Vertical	-5.51
Avg	37.765 GHz	39.763	54	-14.237	133	Vertical	1.295
Avg	38.984 GHz	39.659	54	-14.341	281	Vertical	3.044

**Horizontal**

Source	Frequency	Level (dBµV/m)	Limit (dBµV/m)	Margin (dB)	Azimuth (°)	Pol.	Correction (dB)
Peak	20.449 GHz	53.908	74	-20.092	44	Horizontal	-5.482
Peak	20.491 GHz	53.869	74	-20.131	70	Horizontal	-5.641
Peak	36.967 GHz	53.276	74	-20.724	284	Horizontal	1.54
Peak	39.569 GHz	53.13	74	-20.87	110	Horizontal	3.348

Source	Frequency	Level (dBµV/m)	Limit (dBµV/m)	Margin (dB)	Azimuth (°)	Pol.	Correction (dB)
Avg	20.449 GHz	40.552	54	-13.448	44	Horizontal	-5.482
Avg	20.491 GHz	40.195	54	-13.805	70	Horizontal	-5.641
Avg	36.967 GHz	40.215	54	-13.785	284	Horizontal	1.54
Avg	39.569 GHz	40.116	54	-13.884	110	Horizontal	3.348

**Table 13: Transmitting on the Highest Frequency 6825 MHz – 17 – 40 GHz**

## 5.6 §15.407(a) Maximum Power Spectral Density

The maximum average power spectral density conducted from the intentional radiator of the antenna shall not be greater than 5 dBm EIRP in any 1 MHz band during any time interval of continuous transmission. Results of this testing are summarized.

Modulation (BW)	Frequency (MHz)	Data Rate	TP Setting	Conducted Output Power	Measured PSD	PSD EIRP
HE20	6535	Mcs0	23	14.55	-1.23	4.77
HE20	6695	Mcs0	22	14.44	-1.49	4.51
HE20	6875	Mcs0	25	14.82	-1.00	5.00
HE40	6525	Mcs0	29	17.94	-1.20	4.80
HE40	6685	Mcs0	27	17.48	-1.32	4.68
HE40	6885	Mcs0	30	17.88	-1.13	4.87
HE80	6545	Mcs0	35	20.79	-1.19	4.81
HE80	6705	Mcs0	34	20.74	-1.47	4.53
HE80	6865	Mcs0	36	20.56	-1.46	4.54
HE160	6505	Mcs0	40	23.38	-1.25	4.75
HE160	6665	Mcs0	40	23.62	-1.12	4.88
HE160	6825	Mcs0	42	23.54	-1.14	4.88

### Result

The maximum average power spectral density was less than the limit of 5 dBm EIRP; therefore, the EUT complies with the specification.

## 5.7 §15.407(d) Contention Based Protocol

This product was tested and found to be compliant with the requirements of Contention-based Protocol as specified in FCC Part 15.407 and KDB 987594 D02.

Frequency (MHz)	Sensitivity Level (dBm)	Sensitivity Requirement (dBm)	Trial #									
			1	2	3	4	5	6	7	8	9	10
<b>Bandwidth: 20 MHz</b>			<b>1</b>	<b>2</b>	<b>3</b>	<b>4</b>	<b>5</b>	<b>6</b>	<b>7</b>	<b>8</b>	<b>9</b>	<b>10</b>
6115	-80.39	-62	X	X	X	X	X	X	X	X	X	X
6435	-78.78	-62	X	X	X	X	X	X	X	X	X	X
6535	-79.11	-62	X	X	X	X	X	X	X	X	X	X
6895	-78.55	-62	X	X	X	X	X	X	X	X	X	X
<b>Bandwidth: 160 MHz</b>			<b>1</b>	<b>2</b>	<b>3</b>	<b>4</b>	<b>5</b>	<b>6</b>	<b>7</b>	<b>8</b>	<b>9</b>	<b>10</b>
6112.5 (L)	-67.95	-62	X	X	X	X	X	X	X	X	X	X
6185 (M)	-71.56	-62	X	X	X	X	X	X	X	X	X	X
6257.5 (H)	-67.78	-62	X	X	X	X	X	X	X	X	X	X
6432.5 (L)	-66.32	-62	X	X	X	X	X	X	X	X	X	X
6505 (M)	-72.62	-62	X	X	X	X	X	X	X	X	X	X
6577.5 (H)	-70.22	-62	X	X	X	X	X	X	X	X	X	X
6592.5 (L)	-66.99	-62	X	X	X	X	X	X	X	X	X	X
6665 (M)	-69.63	-62	X	X	X	X	X	X	X	X	X	X
6737.5 (H)	-67.56	-62	X	X	X	X	X	X	X	X	X	X
6912.5 (L)	-65.04	-62	X	X	X	X	X	X	X	X	X	X
6985 (M)	-71.27	-62	X	X	X	X	X	X	X	X	X	X
7057.5 (H)	-70.73	-62	X	X	X	X	X	X	X	X	X	X

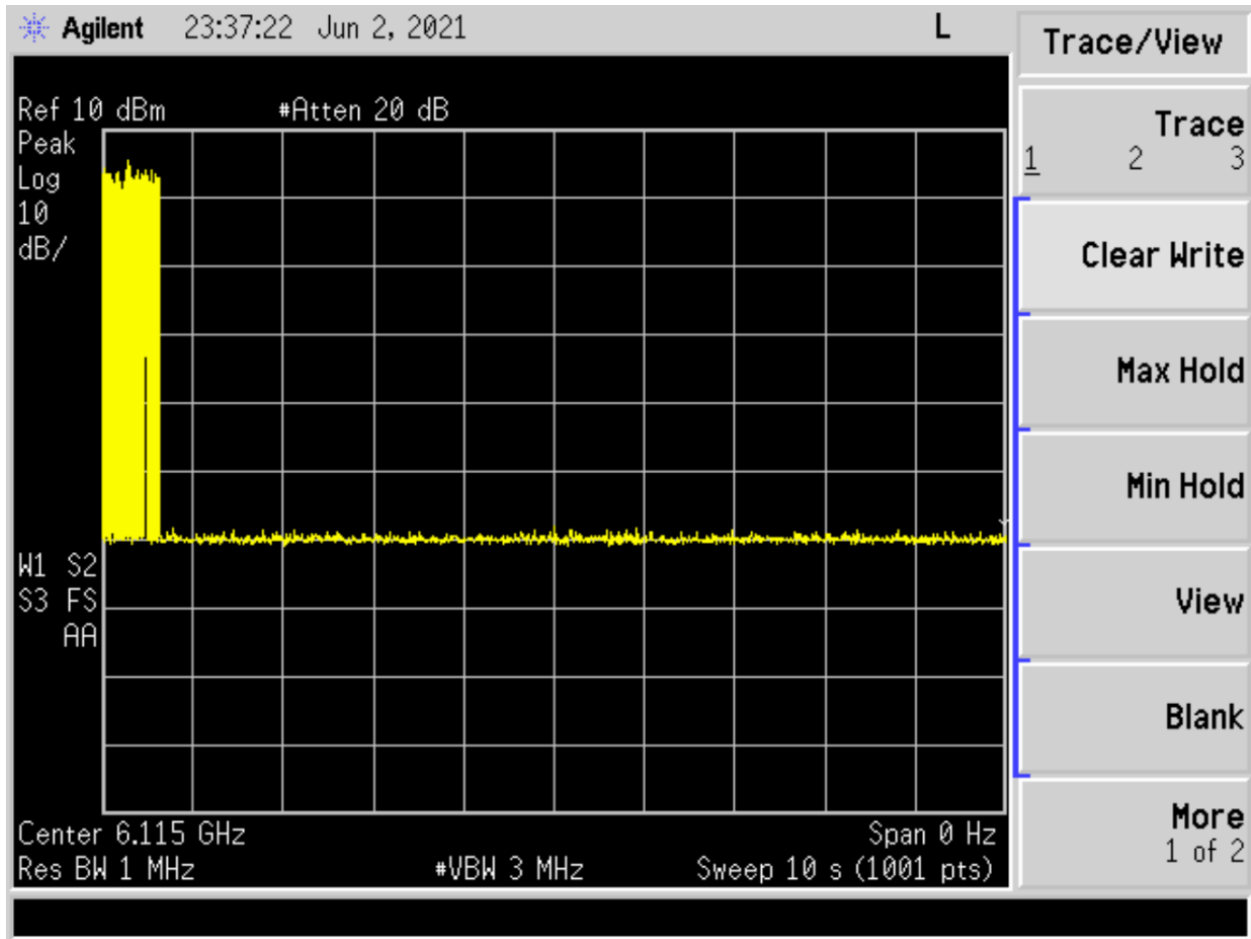

**Plot 1: Example Detection Trace**

**Result**

The EUT complies with the specification.

-- End of Test Report --