



427 West 12800 South
 Draper, UT 84020

Test Report Certification

FCC ID	SWX-U6EP
ISED ID	6545A-U6EP
Equipment Under Test	U6-Enterprise
Test Report Serial Number	TR6137_02
Date of Test(s)	7, 14, 17, 18, 25 May and 2 June 2021
Report Issue Date	8 June 2021

Test Specification	Applicant
47 CFR FCC Part 15, Subpart E	Ubiquiti Inc. 685 Third Avenue New York, NY 10019 U.S.A.



NVLAP LAB CODE 600241-0

Certification of Engineering Report

This report has been prepared by Unified Compliance Laboratory (UCL) to document compliance of the device described below with the requirement of Federal Communication Commissions (FCC) Part 15, Subpart E. This report may be reproduced in full. Partial reproduction of this report may only be made with the written consent of the laboratory. The results in this report apply only to the sample tested.

Applicant	Ubiquiti Inc.
Manufacturer	Ubiquiti Inc.
Brand Name	UniFi
Model Number	U6-Enterprise
FCC ID	SWX-U6EP
ISED ID	6545A-U6EP

On this 8th day of June 2021, I individually and for Unified Compliance Laboratory certify that the statements made in this engineering report are true, complete, and correct to the best of my knowledge and are made in good faith.

Although NVLAP has accredited the Unified Compliance Laboratory testing facilities, this report must not be used to claim product certification, approval, or endorsement by NVLAP, NIST or any agency of the U.S. federal government.

Unified Compliance Laboratory



Written By: Joseph W. Jackson



Reviewed By: Alex Macon

Revision History		
Revision	Description	Date
01	Original Report Release	8 June 2021
02	Amended Sections 3.3.1 and 5.4	11 June 2021

Table of Contents

1	Client Information.....	5
1.1	Applicant.....	5
1.2	Manufacturer.....	5
2	Equipment Under Test (EUT).....	6
2.1	Identification of EUT.....	6
2.2	Description of EUT.....	6
2.3	EUT and Support Equipment.....	7
2.4	Interface Ports on EUT.....	7
2.5	Operating Environment.....	7
2.6	Operating Modes.....	7
2.7	EUT Exercise Software.....	8
2.8	Block Diagram of Test Configuration.....	8
2.9	Modification Incorporated/Special Accessories on EUT.....	8
2.10	Deviation, Opinions Additional Information or Interpretations from Test Standard.....	8
3	Test Specification, Method and Procedures.....	9
3.1	Test Specification.....	9
3.2	Methods & Procedures.....	9
3.3	FCC Part 15, Subpart E.....	9
3.4	Results.....	9
3.5	Test Location.....	9
4	Test Equipment.....	11
4.1	Conducted Emissions at Mains Ports.....	11
4.2	Direct Connect at the Antenna Port Tests.....	11
4.3	Radiated Emissions.....	12
4.4	Equipment Calibration.....	13
4.5	Measurement Uncertainty.....	13
5	Test Results.....	14
5.1	§15.203 Antenna Requirements.....	14
5.2	Conducted Emissions at Mains Ports Data.....	14
5.3	§15.403(i) 26 dB Emissions Bandwidth.....	16
5.4	§15.403(a)(3) Maximum Average Output Power.....	17
5.5	§15.407(b)(7) Spurious Emissions.....	18
5.6	§15.407(a) Maximum Power Spectral Density.....	24
5.7	§15.407(d) Contention Based Protocol.....	25

1 Client Information

1.1 Applicant

Company	Ubiquiti Inc. 685 Third Avenue New York, NY 10017 U.S.A.
Contact Name	Mark Feil
Title	Compliance Manager

1.2 Manufacturer

Company	Ubiquiti Inc. 685 Third Avenue New York, NY 10017 U.S.A.
Contact Name	Mark Feil
Title	Compliance Manager

2 Equipment Under Test (EUT)

2.1 Identification of EUT

Brand Name	UniFi
Model Number	U6-Enterprise
Serial Number	68D79A1F0D5A
Dimensions (cm)	22.0 x 22.0 x 4.8

2.2 Description of EUT

The U6-Enterprise is a four-stream WiFi 6 access point that provides up to 2.4 Gbps aggregate radio rate with 2.4 GHz (2x2), 5 GHz (4x4) and 6 GHz (4x4) radios. The U6-Enterprise is designed for indoor use. The U6-Enterprise has an Ethernet port for data transfer and is powered by an 803.2at PoE power adapter. The U6-Enterprise has a Bluetooth management radio to achieve setup and operation. The table below show the channels used within the different modulation bandwidths.

Band	Modulation Bandwidth	Frequency (MHz)	Maximum Power Setting
UNII-5	ax (HEW20)	6115, 6135, 6155, 6175	TP25
		6195, 6215, 6235, 6255, 6275, 6295, 6315, 6335, 6355, 6375, 6395	TP22
		6415	TP21
	ax (HEW40)	6125, 6165	TP28
		6205, 6245, 6285, 6325, 6385	TP27
		6405	TP26
	ax (HEW80)	6145, 6225, 6305	TP34
		6385	TP33
	ax (HEW160)	6185, 6325	TP39

This report covers the circuitry of the device subject to FCC Part 15, Subpart E. The circuitry of the device subject to FCC Part 15 Subpart B was found to be compliant and is covered under a separate Unified Compliance Laboratory test report.

2.3 EUT and Support Equipment

The EUT and support equipment used during the test are listed below.

Brand Name Model Number Serial Number	Description	Name of Interface Ports / Interface Cables
BN: UniFi MN: U6-Enterprise SN: 68D79A1F0D5A	WiFi Access Point	See Section 2.4
BN: Ubiquiti MN: UPOE-at SN: N/A	PoE Power Adapter	Shielded or Un-Shielded Cat 5e cable (Note 2)
BN: Dell MN: XPS 13 SN: N/A	Laptop Personal Computer	Shielded or Un-Shielded Cat 5e cable (Note 2)

Notes: (1) EUT

(2) Interface port connected to EUT (See Section 2.4)

The support equipment listed above was not modified in order to achieve compliance with this standard.

2.4 Interface Ports on EUT

Name of Ports	No. of Ports Fitted to EUT	Cable Description/Length
PoE	1	Shielded or Un-Shielded Cat 5e Cable/> 3 meters
Data	1	Shielded or Un-Shielded Cat 5e Cable/> 3 Meters

2.5 Operating Environment

Power Supply	120 Volts ac to 48 Volts PoE Power
AC Mains Frequency	60 Hz
Temperature	21.3 – 21.8 °C
Humidity	22.0 – 24.7 %
Barometric Pressure	1019 mBar

2.6 Operating Modes

The U6-Enterprise was tested using test software in order to enable to constant transmission of over 98% All emission modes of 802.11ax were investigated. All measurements are reported with the worst-case mode (802.11ax) unless otherwise stated.

2.7 EUT Exercise Software

EUT firmware version 1.0 was used to operate the transmitter using a constant transmit mode.

2.8 Block Diagram of Test Configuration

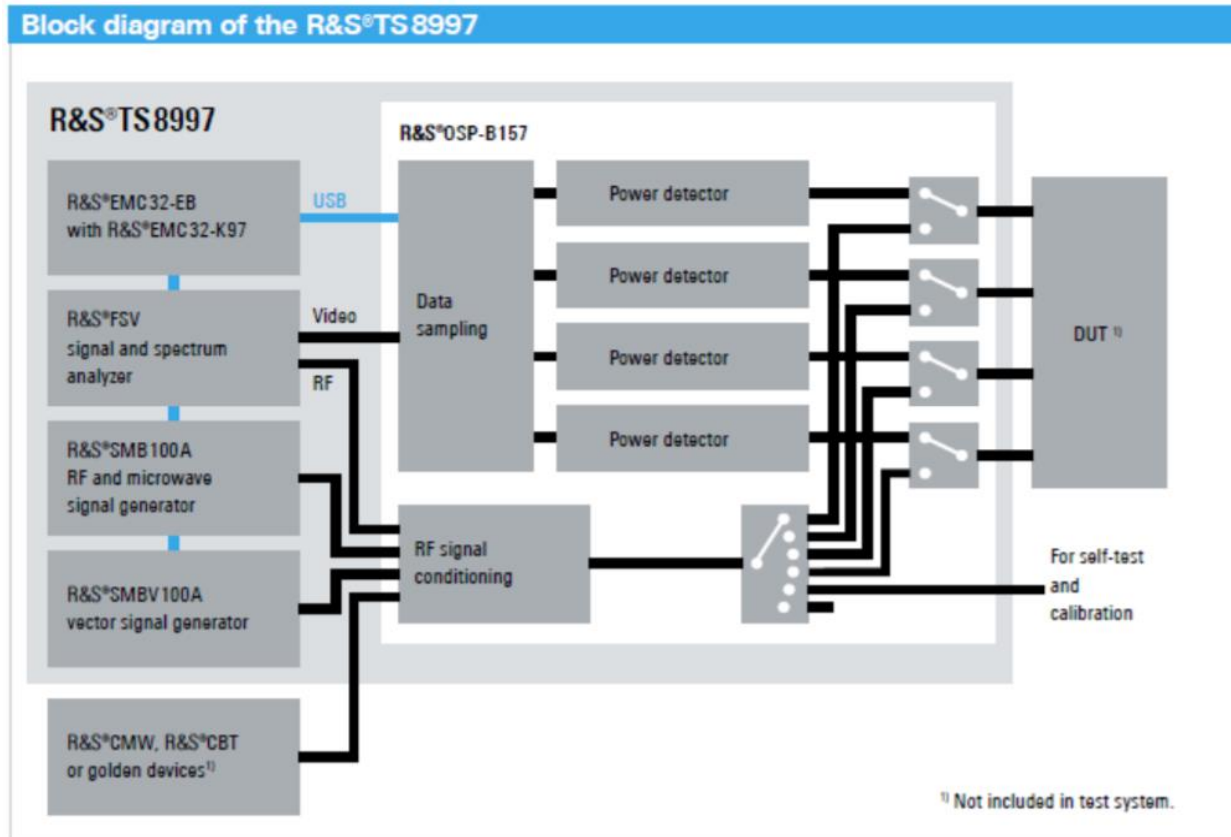

Diagram 1: Test Configuration Block Diagram

2.9 Modification Incorporated/Special Accessories on EUT

There were no modifications made to the EUT during testing to comply with the specification.

2.10 Deviation, Opinions Additional Information or Interpretations from Test Standard

There were no deviations, opinions, additional information or interpretations from the test specification.

3 Test Specification, Method and Procedures

3.1 Test Specification

Title	47 CFR FCC Part 15, Subpart E, Section 15.407 Limits and methods of measurement of radio interference characteristics of Unlicensed National Information Infrastructure Devices
Purpose of Test	The tests were performed to demonstrate initial compliance

3.2 Methods & Procedures

3.2.1 47 CFR FCC Part 15 Section 15.407

See test standard for details.

3.3 FCC Part 15, Subpart E

3.3.1 Summary of Tests

FCC Section	ISED Section	Environmental Phenomena	Frequency Range (MHZ)	Result
15.203	N/A	Antenna requirements	Structural Requirement	Compliant
15.207	RSS-Gen	Conducted Disturbance at Mains Port	0.15 to 30	Compliant
15.407(a)	RSS-247 §6.2.2, §6.2.3	Bandwidth Requirement	5955 to 6415	Compliant
15.407(a)	RSS-247 §6.2.2, §6.2.3	Peak Output Power	5955 to 6415	Compliant
15.407(f)	RSS-247 §6.2.2, §6.2.3	Antenna Conducted Spurious Emissions	0.009 to 40000	N/A
15.407(a)	RSS-247 §6.2.2, §6.2.3	Radiated Spurious Emissions	0.009 to 40000	Compliant
15.407(a)	RSS-247 §6.2.2, §6.2.3	Peak Power Spectral Density	5955 to 6415	Compliant
15.407(d)	RSS-247 §6.2.2, §6.2.3	Contention Based Protocol	5955 to 6415	Compliant

The testing was performed according to the procedures in ANSI C63.10-2013, KDB 789033 and 47 CFR Part 15. Where applicable, KDB 662911 was followed to sum required measurements.

3.4 Results

In the configuration tested, the EUT complied with the requirements of the specification.

3.5 Test Location

Testing was performed at the Unified Compliance Laboratory 3-Meter and 10-Meter chambers located at 427 West 12800 South, Draper, UT 84020. Unified Compliance Laboratory is accredited by National

Voluntary Laboratory Accreditation Program (NVLAP); NVLAP Code 600241-0 which is effective until 30 June 2021. This site has also been registered with Innovations, Science and Economic Development (ISED) department as was accepted under Appendix B, Phase 1 procedures of the APEC Tel MRA for Canadian recognition. ISED No.: 25346, effective until June 30, 2021. Unified Compliance Laboratory has been assigned Conformity Assessment Number US0223 by ISED.

4 Test Equipment

4.1 Conducted Emissions at Mains Ports

Type of Equipment	Manufacturer	Model Number	Asset Number	Date of Last Calibration	Due Date of Calibration
EMI Receiver	AFJ	FFT3010	UCL-2500	9/18/2020	9/17/2021
LISN	AFJ	LS16C/10	UCL-2512	5/26/2020	5/26/2022
Cat6 ISN	Teseq	ISN T8-Cat6	UCL-2971	5/18/2020	5/18/2022
ISN	Teseq	ISN T800	UCL-2974	6/1/2020	6/1/2021
LISN	Com-Power	LIN-120C	UCL-2612	5/19/2021	5/19/2022
AC Power Source	Laplace Instruments	AC1000A	UCL-2857	N/A	N/A
Test Software	UCL	Revision 1	UCL-3107	N/A	N/A

Table 1: List of equipment used for Conducted Emissions Testing at Mains Port

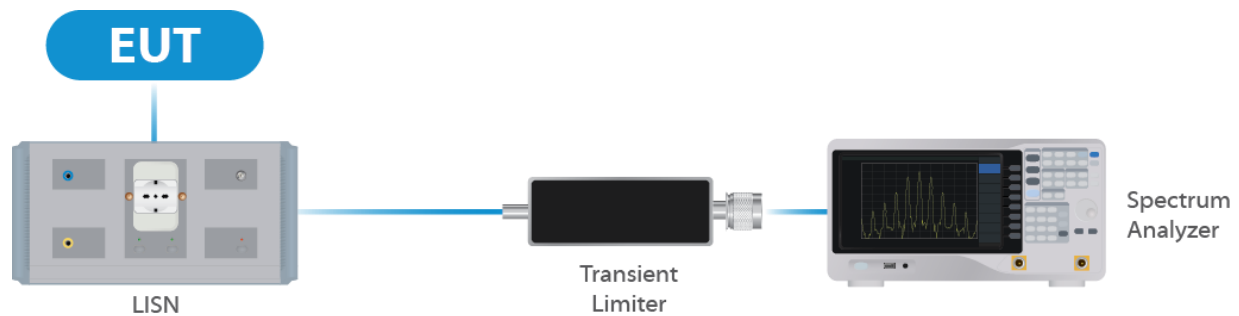

Figure 1: Conducted Emissions Test

4.2 Direct Connect at the Antenna Port Tests

Type of Equipment	Manufacturer	Model Number	Asset Number	Date of Last Calibration	Due Date of Calibration
Spectrum Analyzer	R&S	FSV40	UCL-2861	8/24/2020	8/24/2021
Signal Generator	R&S	SMB100A	UCL-2864	N/A	N/A
Vector Signal Generator	R&S	SMBV100A	UCL-2873	N/A	N/A
Switch Extension	R&S	OSP-B157WX	UCL-2867	9/8/2020	9/8/2021
Switch Extension	R&S	OSP-150W	UCL-2870	3/3/2021	3/3/2022

Table 2: List of equipment used for Direct Connect at the Antenna Port

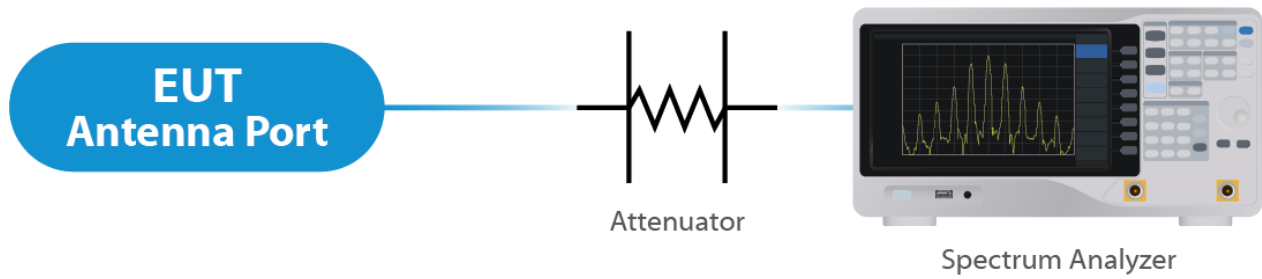

Figure 2: Direct Connect at the Antenna Port Test

4.3 Radiated Emissions

Type of Equipment	Manufacturer	Model Number	Asset Number	Date of Last Calibration	Due Date of Calibration
EMI Receiver	Keysight	N9038A	UCL-2778	6/1/2020	6/1/2021
Pre-Amplifier 9 kHz – 1 GHz	Sonoma Instruments	310N	UCL-2889	9/10/2020	9/10/2021
Double Ridge Horn Antenna	Scwarzbeck	BBHA 9120D	UCL-3065	7/8/2020	7/8/2021
Log Periodic	Scwarzbeck	STLP 9129	UCL-3068	11/16/2020	11/16/2021
15 - 40 GHz Horn Antenna	Scwarzbeck	BBHA 9170	UCL-2487	5/21/2020	5/21/2022
1 – 18 GHz Amplifier	Com-Power	PAM 118A	UCL-3833	9/29/2020	9/29/2021
Test Software	UCL	Revision 1	UCL-3108	N/A	N/A

Table 3:List of equipment used for Radiated Emissions

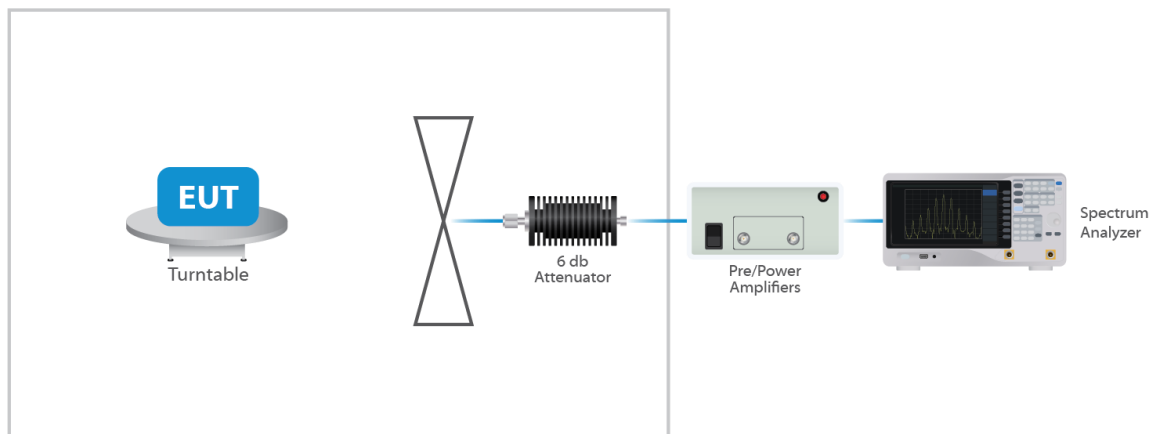

Figure 3: Radiated Emissions Test

4.4 Equipment Calibration

All applicable equipment is calibrated using either an independent calibration laboratory or Unified Compliance Laboratory personnel at intervals defined in ANSI C63.4:2014 following outlined calibration procedures. All measurement instrumentation is traceable to the National Institute of Standards and Technology (NIST). Supporting documentation relative to traceability is on file and is available for examination upon request.

4.5 Measurement Uncertainty

Test	Uncertainty (\pm dB)	Confidence (%)
Conducted Emissions	1.44	95
Radiated Emissions (9 kHz to 30 MHz)	2.50	95
Radiated Emissions (30 MHz to 1 GHz)	4.38	95
Radiated Emissions (1 GHz to 18 GHz)	4.37	95
Radiated Emissions (18 GHz to 40 GHz)	3.93	95
Direct Connect Tests	K Factor	Value
Emissions Bandwidth	2	2.0%
Output Power	2	1.0 dB
Peak Power Spectral Density	2	1.3 dB
Band Edge	2	0.8 dB
Transmitter Spurious Emissions	2	1.8 dB

5 Test Results

5.1 §15.203 Antenna Requirements

The EUT uses an integral antenna. The Maximum gain of the antenna is 6.0 dBi. The antenna is not user replaceable.

Results

The EUT complied with the specification

5.2 Conducted Emissions at Mains Ports Data

5.2.1 Line

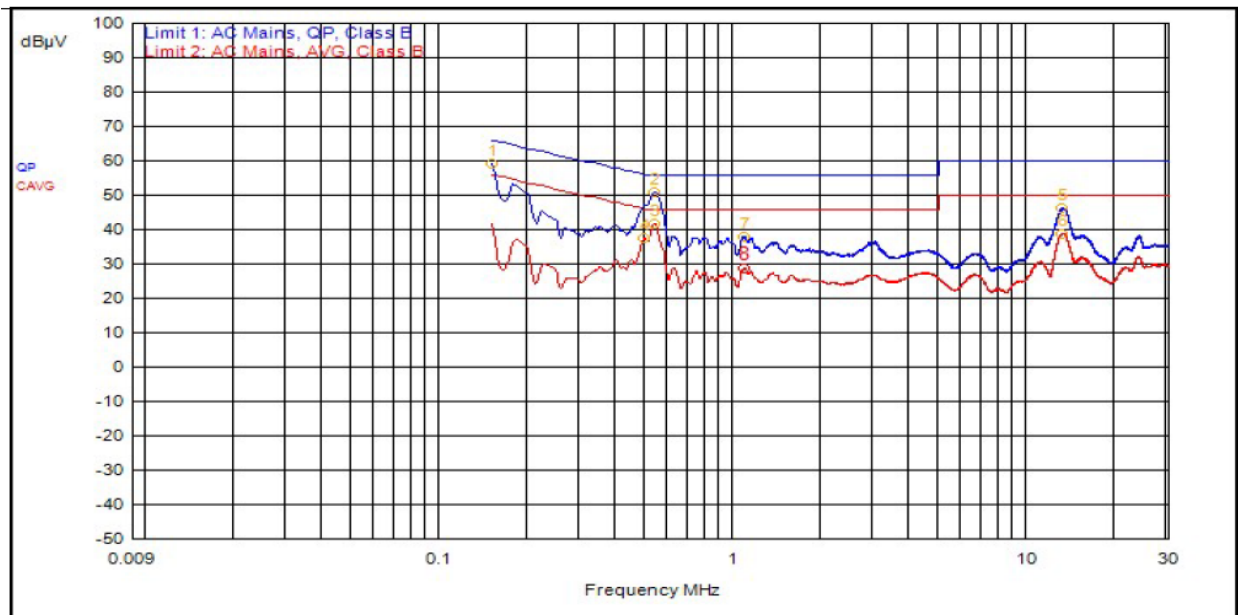

ID	Frequency	Probe	Cable	Atten.	Detector	Meter Read	Meas Level	Limit 1	Limit 1 Dist.	Limit 2	Limit 2 Dist.
2	534,000kHz	12.4			QPeak	38.3	50.7	56.0	-5.3		
1	150,000kHz	12.4			QPeak	46.8	59.2	66.0	-6.8		
5	13.041MHz	12.4			QPeak	33.7	46.2	60.0	-13.8		
7	1.083MHz	12.4			QPeak	25.4	37.8	56.0	-18.2		
3	537,000kHz	12.4			C_AVG	29.2	41.6			46.0	-4.4
4	495,000kHz	12.4			C_AVG	25.1	37.5			46.1	-8.6
6	13.041MHz	12.4			C_AVG	26.4	38.8			50.0	-11.2
8	1.083MHz	12.4			C_AVG	16.3	28.7			46.0	-17.3

5.2.2 Neutral

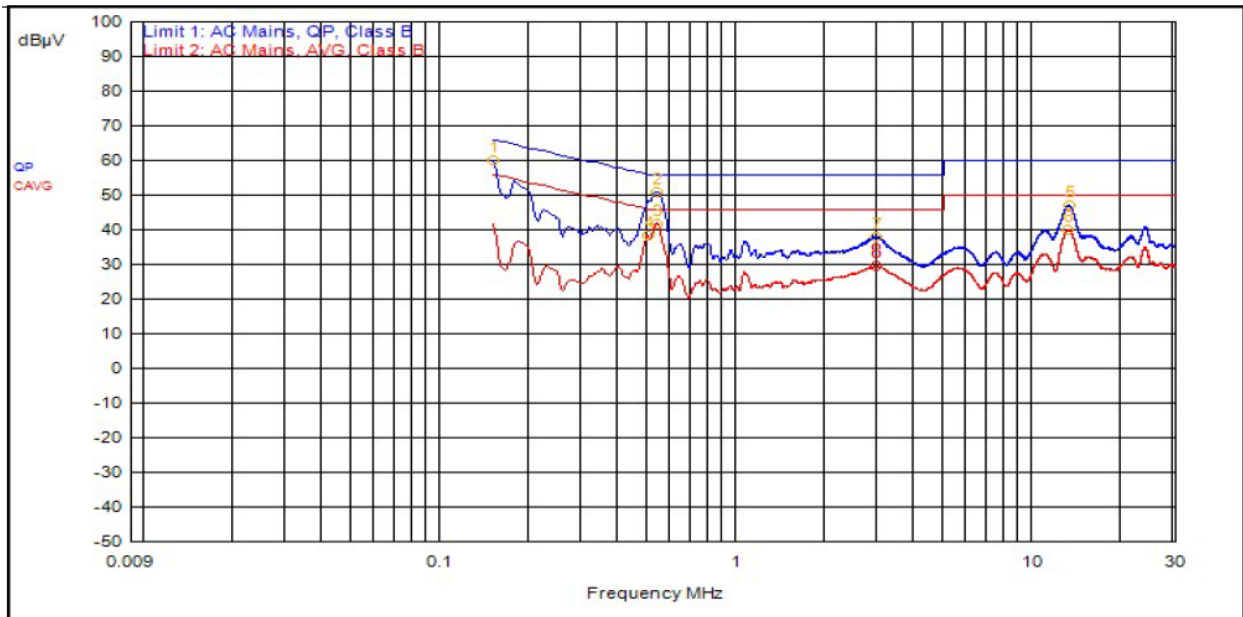

ID	Frequency	Probe	Cable	Atten.	Detector	Meter Read	Meas Level	Limit 1	Limit 1 Dist.	Limit 2	Limit 2 Dist.
2	531,000kHz	12.4			QPeak	38.4	50.8	56.0	-5.2		
1	150,000kHz	12.4			QPeak	47.5	59.9	66.0	-6.1		
5	13.080MHz	12.4			QPeak	34.5	46.9	60.0	-13.1		
7	2.940MHz	12.3			QPeak	25.7	38.0	56.0	-18.0		
3	531,000kHz	12.4			C_AVG	29.4	41.8			46.0	-4.2
4	498,000kHz	12.4			C_AVG	25.9	38.3			46.0	-7.8
6	12.963MHz	12.4			C_AVG	27.5	39.9			50.0	-10.1
8	2.928MHz	12.3			C_AVG	17.2	29.5			46.0	-16.5

Result

The EUT complied with the specification limit.

5.3 §15.403(i) 26 dB Emissions Bandwidth

Nominal BW (MHz)	Frequency (MHz)	99% Bandwidth (MHz)	26 dB Bandwidth (MHz)
20	6115	17.8	20.8
20	6195	17.8	21.9
20	6415	17.8	21.4
40	6125	36.3	39.3
40	6205	36.3	39.5
40	6405	36.3	39.2
80	6145	75.5	82.5
80	6225	75.5	82.0
80	6385	75.5	81.5
160	6185	155.0	164.0
160	6325	155.0	165.0

Result

The 26 dB bandwidths are reported for information purposes. Please see Annex for all bandwidth measurements.

5.4 §15.403(a)(3) Maximum Average Output Power

The maximum average RF conducted output power measured for this device was 22.78 dBm or 189.67 mW. The limit is 30 dBm EIRP, or 1 Watt EIRP. The antenna has a gain of 6.0 dBi.

Modulation (BW)	Frequency (MHz)	Data Rate	TP Setting	Conducted Output Power *	Output Power EIRP	Measured PSD
HE20	6115	Mcs0	25	15.36	21.36	-1.21
HE20	6195	Mcs0	22	13.88	19.88	-1.24
HE20	6415	Mcs0	21	14.51	20.51	-1.26
HE40	6125	Mcs0	28	17.20	23.20	-1.02
HE40	6205	Mcs0	27	16.84	22.84	-1.46
HE40	6405	Mcs0	26	17.41	23.41	-1.58
HE80	6145	Mcs0	34	20.18	26.18	-1.27
HE80	6225	Mcs0	34	20.59	26.59	-1.31
HE80	6385	Mcs0	33	20.68	26.68	-1.39
HE160	6185	Mcs0	39	22.69	28.69	-1.29
HE160	6325	Mcs0	39	22.78	28.78	-1.40

Result

In the configuration tested, the maximum average RF outpower was less than 1 watt EIRP; therefore, the EUT complied with the requirements of the specification (see spectrum analyzer plots in attached Annex).

* Gated EIRP shown in the Annex is the conducted measurement

5.5 §15.407(b)(7) Spurious Emissions

5.5.1 Conducted Spurious Emissions

The frequency ranges from the lowest frequency generated or used in the device to the tenth harmonic of the highest fundamental frequency was investigated to measure any antenna-conducted emissions. The graphs show the measurement data from spurious emissions noted across the frequency range when transmitting at the lowest frequency, middle frequency and upper frequency. Shown below are plots with the EUT turned to the upper and lower channels with the antenna gain of 6.0 dBi accounted for. These demonstrate compliance with the provisions of this section at the band edges.

The emissions must be remaining below -27 dBm EIRP.

Result

Conducted spurious emissions were attenuated below the limit; therefore, the EUT complies with the specification.

5.5.2 Radiated Spurious Emissions in the Restricted Bands of § 15.205

The EUT uses various power settings based on the channel in use. In order to reduce test time, the radiated spurious emissions at the lowest, middle, and highest channel were measured at the maximum power of TP39.

Result

All emissions in the restricted bands of § 15.205 met the limits specified in § 15.209; therefore, the EUT complies with the specification. See Annex for Conducted Band edge plots.

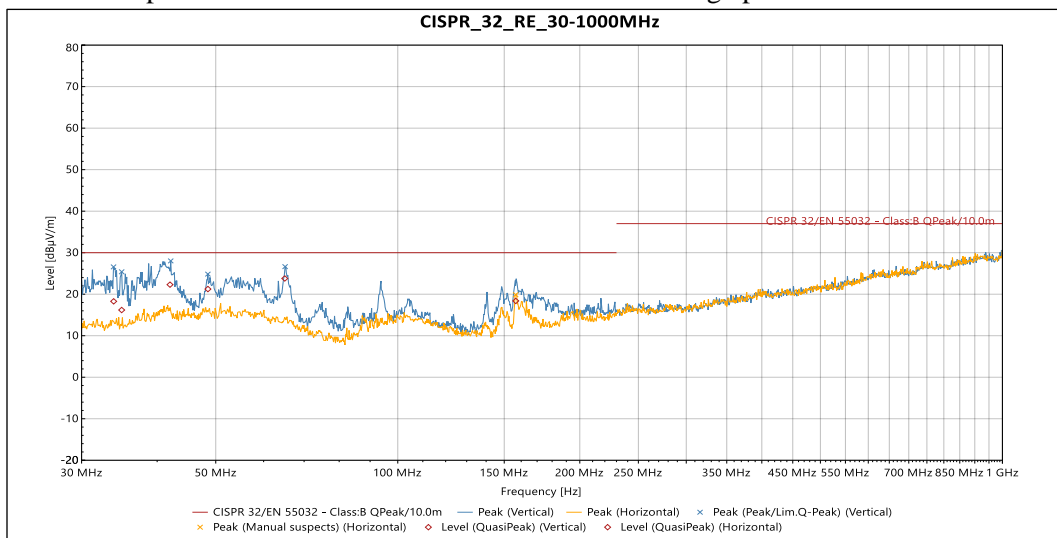

Vertical

Source	Frequency	Level (dBµV/m)	Limit (dBµV/m)	Margin	Azimuth (°)	Height	Pol.	Correction (dB)
QuasiPeak	33.896 MHz	18.279	30	-11.721	81	1.106	Vertical	-15.184
QuasiPeak	34.945 MHz	16.188	30	-13.812	319	1.946	Vertical	-14.833
QuasiPeak	42.009 MHz	22.297	30	-7.703	73	2.164	Vertical	-12.832
QuasiPeak	48.534 MHz	21.24	30	-8.76	20	2.62	Vertical	-12.359
QuasiPeak	65.031 MHz	23.786	30	-6.214	108	2.835	Vertical	-14.684

Horizontal

Source	Frequency	Level (dBμV/m)	Limit (dBμV/m)	Margin	Azimuth (°)	Height	Pol.	Correction (dB)
QuasiPeak	156.72 MHz	18.377	30	-11.623	235	3.995	Horizontal	-17.354

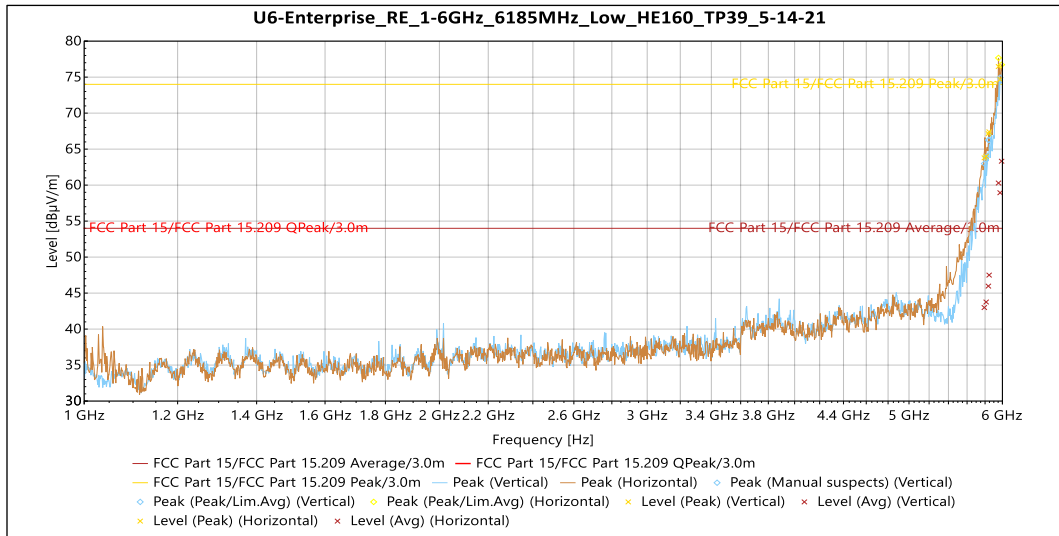
Table 4: Radiated Emissions 30 – 1000 MHz

Vertical – No significant emissions were observed in this orientation of the antenna from 1 – 6 GHz

Horizontal – No significant emission were observed in this orientation of the antenna from 1 – 6 GHz.

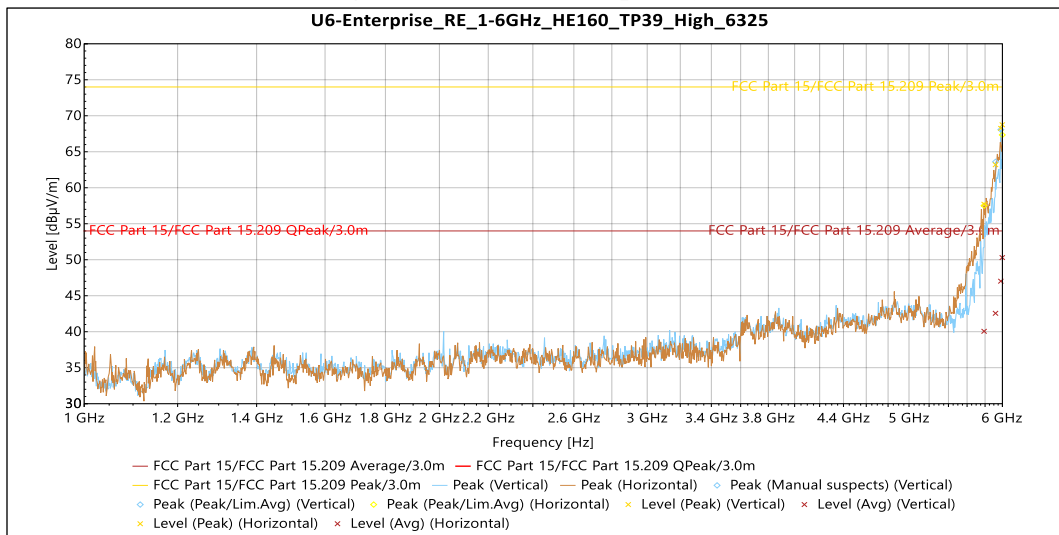
Table 5: Transmitting on the Lowest Frequency 6185 MHz – 1 – 6 GHz

Vertical – No significant emissions were observed in this orientation of the antenna from 1 – 6 GHz

Horizontal – No significant emissions were observed in this orientation of the antenna from 1 – 6 GHz.

Table 6: Transmitting on the Highest Frequency 6325 MHz – 1 – 6 GHz

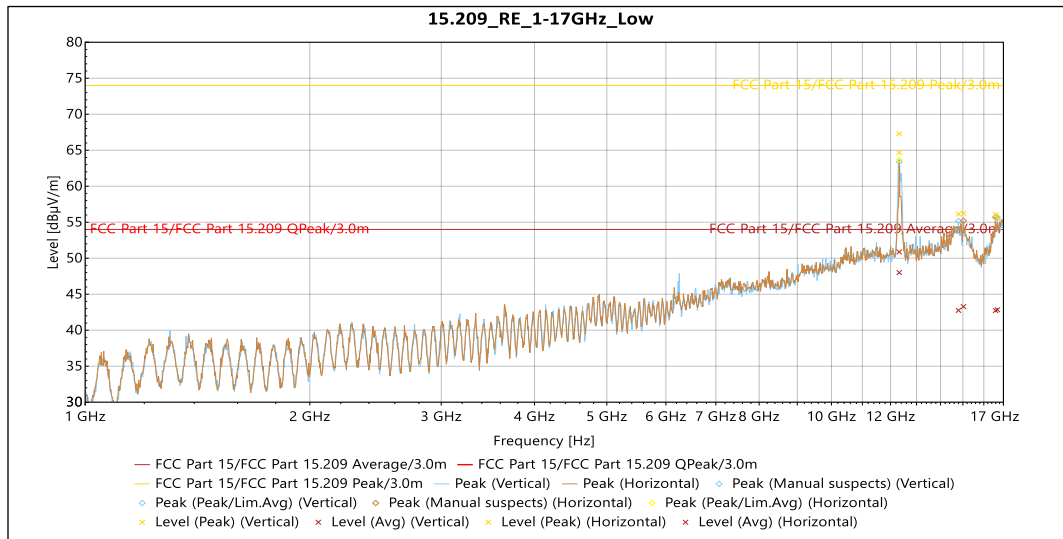
Vertical

Source	Frequency	Level (dBµV/m)	Limit (dBµV/m)	Margin (dB)	Azimuth (°)	Height (m)	Pol.	Correction (dB)
Peak	12.327 GHz	67.287	74	-6.713	29	1.5	Vertical	6.222
Peak	14.8 GHz	56.123	74	-17.877	134	1.635	Vertical	9.461
Peak	16.688 GHz	55.536	74	-18.464	39	1.631	Vertical	11.172

Source	Frequency	Level (dBµV/m)	Limit (dBµV/m)	Margin (dB)	Azimuth (°)	Height (m)	Pol.	Correction (dB)
Avg	12.327 GHz	50.879	54	-3.121	29	1.5	Vertical	6.222
Avg	14.8 GHz	42.75	54	-11.25	134	1.635	Vertical	9.461
Avg	16.688 GHz	42.835	54	-11.165	39	1.631	Vertical	11.172

Horizontal

Source	Frequency	Level (dBµV/m)	Limit (dBµV/m)	Margin (dB)	Azimuth (°)	Height (m)	Pol.	Correction (dB)
Peak	12.327 GHz	64.659	74	-9.341	297	2.138	Horizontal	6.222
Peak	15.029 GHz	56.236	74	-17.764	273	2.138	Horizontal	10.174
Peak	16.592 GHz	56.075	74	-17.925	239	2.138	Horizontal	10.828

Source	Frequency	Level (dBµV/m)	Limit (dBµV/m)	Margin (dB)	Azimuth (°)	Height (m)	Pol.	Correction (dB)
Avg	12.327 GHz	47.998	54	-6.002	297	2.138	Horizontal	6.222
Avg	15.029 GHz	43.278	54	-10.722	273	2.138	Horizontal	10.174
Avg	16.592 GHz	42.73	54	-11.27	239	2.138	Horizontal	10.828

Table 7: Transmitting on the Lowest Frequency 6185 MHz – 6 – 17 GHz

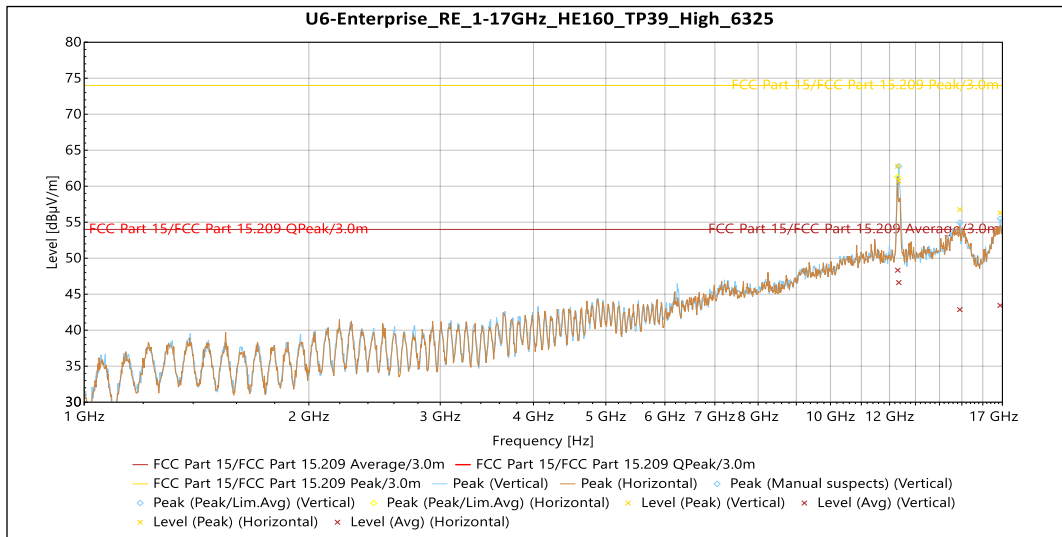
Vertical

Source	Frequency	Level (dBµV/m)	Limit (dBµV/m)	Margin (dB)	Azimuth (°)	Height (m)	Pol.	Correction (dB)
Peak	12.347 GHz	60.725	74	-13.275	20	3.315	Vertical	5.614
Peak	14.907 GHz	56.757	74	-17.243	356	2.824	Vertical	10.092
Peak	16.886 GHz	56.3	74	-17.7	240	2.333	Vertical	12.057

Source	Frequency	Level (dBµV/m)	Limit (dBµV/m)	Margin (dB)	Azimuth (°)	Height (m)	Pol.	Correction (dB)
Avg	12.347 GHz	46.618	54	-7.382	20	3.315	Vertical	5.614
Avg	14.907 GHz	42.862	54	-11.138	356	2.824	Vertical	10.092
Avg	16.886 GHz	43.438	54	-10.562	240	2.333	Vertical	12.057

Horizontal

Source	Frequency	Level (dBµV/m)	Limit (dBµV/m)	Margin (dB)	Azimuth (°)	Height (m)	Pol.	Correction (dB)
Peak	12.308 GHz	62.771	74	-11.229	59	1.5	Horizontal	6.518

Source	Frequency	Level (dBµV/m)	Limit (dBµV/m)	Margin (dB)	Azimuth (°)	Height (m)	Pol.	Correction (dB)
Avg	12.308 GHz	48.328	54	-5.672	59	1.5	Horizontal	6.518

Table 8: Transmitting on the Highest Frequency 6325 MHz – 6 – 17 GHz

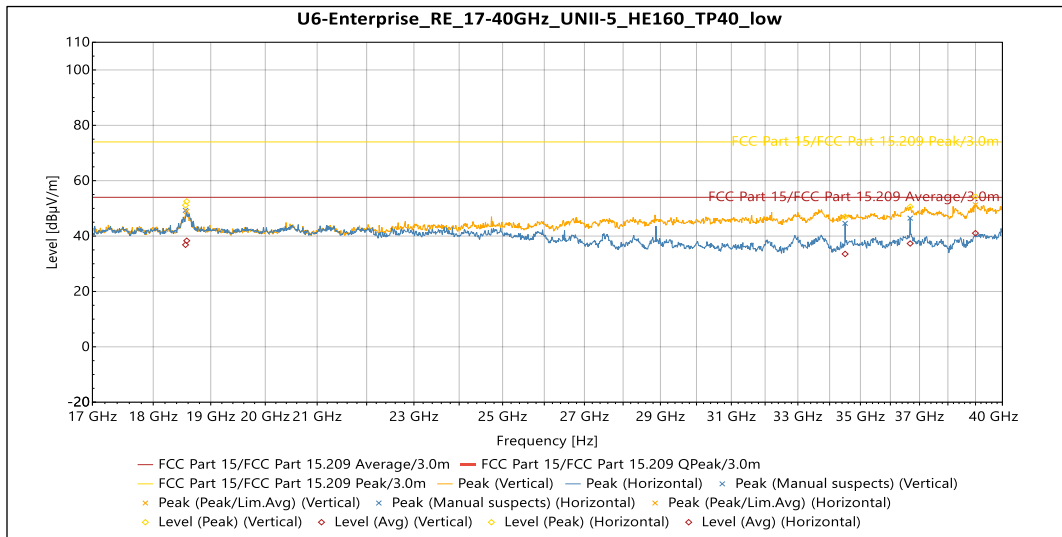
Vertical

Source	Frequency	Level (dBµV/m)	Limit (dBµV/m)	Margin (dB)	Azimuth (°)	Pol.	Correction (dB)
Peak	18.555 GHz	51.117	74	-22.883	22	Vertical	-6.191
Peak	38.998 GHz	54.261	74	-19.739	262	Vertical	3.056

Source	Frequency	Level (dBµV/m)	Limit (dBµV/m)	Margin (dB)	Azimuth (°)	Pol.	Correction (dB)
Avg	18.555 GHz	36.832	54	-17.168	22	Vertical	-6.191
Avg	38.998 GHz	41.045	54	-12.955	262	Vertical	3.056

Horizontal

Source	Frequency	Level (dBµV/m)	Limit (dBµV/m)	Margin (dB)	Azimuth (°)	Pol.	Correction (dB)
Peak	18.576 GHz	52.521	74	-21.479	289	Horizontal	-6.01
Peak	34.5 GHz	46.998	74	-27.002	102	Horizontal	0.37
Peak	36.677 GHz	50.578	74	-23.422	60	Horizontal	1.102

Source	Frequency	Level (dBµV/m)	Limit (dBµV/m)	Margin (dB)	Azimuth (°)	Pol.	Correction (dB)
Avg	18.576 GHz	38.321	54	-15.679	289	Horizontal	-6.01
Avg	34.5 GHz	33.531	54	-20.469	102	Horizontal	0.37
Avg	36.677 GHz	37.307	54	-16.693	60	Horizontal	1.102

Table 9: Transmitting on the Lowest Frequency 6185 MHz – 17 – 40 GHz

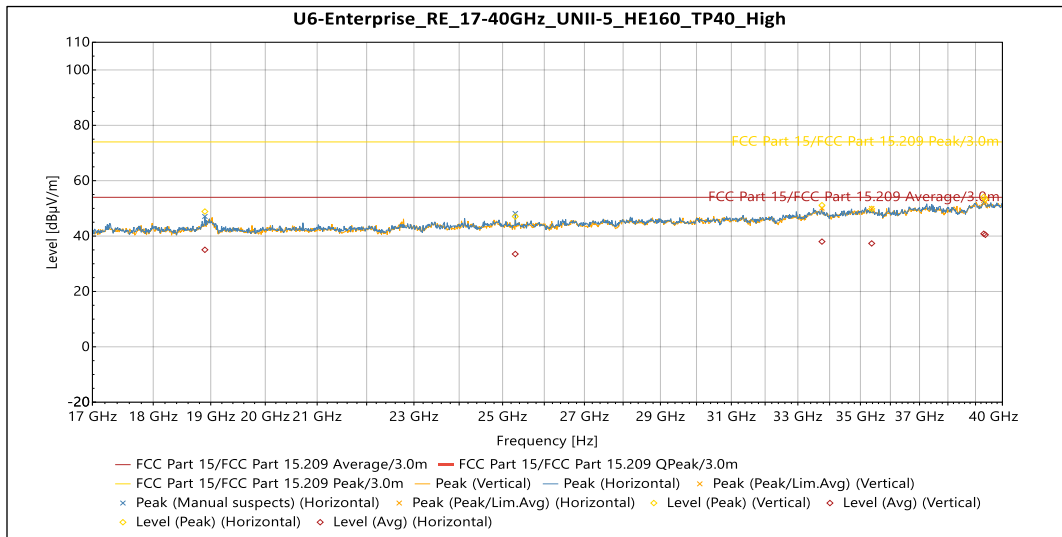
Vertical

Source	Frequency	Level (dBµV/m)	Limit (dBµV/m)	Margin (dB)	Azimuth (°)	Pol.	Correction (dB)
Peak	33.757 GHz	51.152	74	-22.848	268	Vertical	1.299
Peak	35.373 GHz	49.828	74	-24.172	18	Vertical	0.567
Peak	39.363 GHz	53.353	74	-20.647	11	Vertical	3.095

Source	Frequency	Level (dBµV/m)	Limit (dBµV/m)	Margin (dB)	Azimuth (°)	Pol.	Correction (dB)
Avg	33.757 GHz	38.004	54	-15.996	268	Vertical	1.299
Avg	35.373 GHz	37.34	54	-16.66	18	Vertical	0.567
Avg	39.363 GHz	40.463	54	-13.537	11	Vertical	3.095

Horizontal

Source	Frequency	Level (dBµV/m)	Limit (dBµV/m)	Margin (dB)	Azimuth (°)	Pol.	Correction (dB)
Peak	18.896 GHz	48.87	74	-25.13	331	Horizontal	-6.214
Peak	25.3 GHz	47.027	74	-26.973	32	Horizontal	-5.624
Peak	39.304 GHz	54.127	74	-19.873	29	Horizontal	3.317

Source	Frequency	Level (dBµV/m)	Limit (dBµV/m)	Margin (dB)	Azimuth (°)	Pol.	Correction (dB)
Avg	18.896 GHz	35.037	54	-18.963	331	Horizontal	-6.214
Avg	25.3 GHz	33.521	54	-20.479	32	Horizontal	-5.624
Avg	39.304 GHz	40.827	54	-13.173	29	Horizontal	3.317

Table 10: Transmitting on the Highest Frequency 6325 MHz – 17 – 40 GHz

5.6 §15.407(a) Maximum Power Spectral Density

The maximum average power spectral density conducted from the intentional radiator of the antenna shall not be greater than 5 dBm EIRP in any 1 MHz band during any time interval of continuous transmission. Results of this testing are summarized.

Modulation (BW)	Frequency (MHz)	Data Rate	TP Setting	Conducted Output Power	Measured PSD	PSD EIRP
HE20	6115	Mcs0	25	15.36	-1.21	4.79
HE20	6195	Mcs0	22	13.88	-1.24	4.76
HE20	6415	Mcs0	21	14.51	-1.26	4.74
HE40	6125	Mcs0	28	17.20	-1.02	4.98
HE40	6205	Mcs0	27	16.84	-1.46	4.54
HE40	6405	Mcs0	26	17.41	-1.58	4.42
HE80	6145	Mcs0	34	20.18	-1.27	4.73
HE80	6225	Mcs0	34	20.59	-1.31	4.69
HE80	6385	Mcs0	33	20.68	-1.39	4.61
HE160	6185	Mcs0	39	22.69	-1.29	4.71
HE160	6325	Mcs0	39	22.78	-1.40	4.60

Result

The maximum average power spectral density was less than the limit of 5 dBm EIRP; therefore, the EUT complies with the specification.

5.7 §15.407(d) Contention Based Protocol

This product was tested and found to be compliant with the requirements of Contention-based Protocol as specified in FCC Part 15.407 and KDB 987594 D02.

Frequency (MHz)	Sensitivity Level (dBm)	Sensitivity Requirement (dBm)	Trial #									
			1	2	3	4	5	6	7	8	9	10
Bandwidth: 20 MHz			1	2	3	4	5	6	7	8	9	10
6115	-80.39	-62	X	X	X	X	X	X	X	X	X	X
6435	-78.78	-62	X	X	X	X	X	X	X	X	X	X
6535	-79.11	-62	X	X	X	X	X	X	X	X	X	X
6895	-78.55	-62	X	X	X	X	X	X	X	X	X	X
Bandwidth: 160 MHz			1	2	3	4	5	6	7	8	9	10
6112.5 (L)	-67.95	-62	X	X	X	X	X	X	X	X	X	X
6185 (M)	-71.56	-62	X	X	X	X	X	X	X	X	X	X
6257.5 (H)	-67.78	-62	X	X	X	X	X	X	X	X	X	X
6432.5 (L)	-66.32	-62	X	X	X	X	X	X	X	X	X	X
6505 (M)	-72.62	-62	X	X	X	X	X	X	X	X	X	X
6577.5 (H)	-70.22	-62	X	X	X	X	X	X	X	X	X	X
6592.5 (L)	-66.99	-62	X	X	X	X	X	X	X	X	X	X
6665 (M)	-69.63	-62	X	X	X	X	X	X	X	X	X	X
6737.5 (H)	-67.56	-62	X	X	X	X	X	X	X	X	X	X
6912.5 (L)	-65.04	-62	X	X	X	X	X	X	X	X	X	X
6985 (M)	-71.27	-62	X	X	X	X	X	X	X	X	X	X
7057.5 (H)	-70.73	-62	X	X	X	X	X	X	X	X	X	X

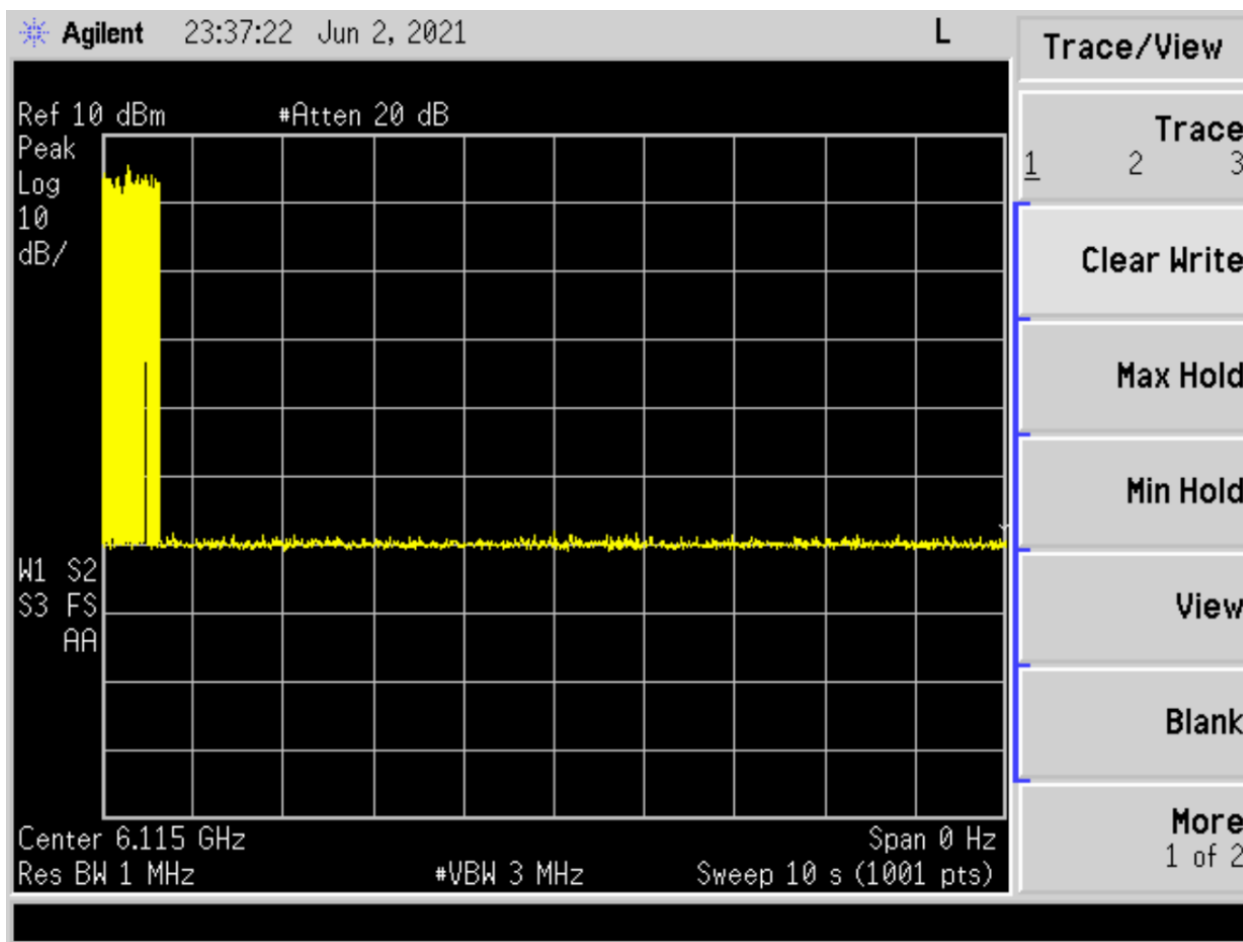

Plot 1: Example Detection Trace

Result

The EUT complies with the specification.

-- End of Test Report --