



427 West 12800 South
 Draper, UT 84020

Test Report Certification

FCC ID	SWX-U6EP
ISED ID	6545A-U6EP
Equipment Under Test	U6-Enterprise
Test Report Serial Number	TR6129_02
Date of Test(s)	18, 25 May and 2, 4 June 2021
Report Issue Date	8 June 2021

Test Specification	Applicant
47 CFR FCC Part 15, Subpart E	Ubiquiti Inc. 685 Third Avenue New York, NY 10019 U.S.A.



NVLAP LAB CODE 600241-0

Certification of Engineering Report

This report has been prepared by Unified Compliance Laboratory (UCL) to document compliance of the device described below with the requirement of Federal Communication Commissions (FCC) Part 15, Subpart E. This report may be reproduced in full. Partial reproduction of this report may only be made with the written consent of the laboratory. The results in this report apply only to the sample tested.

Applicant	Ubiquiti Inc.
Manufacturer	Ubiquiti Inc.
Brand Name	UniFi
Model Number	U6-Enterprise
FCC ID	SWX-U6EP
ISED ID	6545A-U6EP

On this 8th day of June 2021, I individually and for Unified Compliance Laboratory certify that the statements made in this engineering report are true, complete and correct to the best of my knowledge and are made in good faith.

Although NVLAP has accredited the Unified Compliance Laboratory testing facilities, this report must not be used to claim product certification, approval, or endorsement by NVLAP, NIST or any agency of the U.S. federal government.

Unified Compliance Laboratory



Written By: Joseph W. Jackson

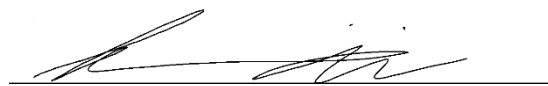

Reviewed By: Alex Macon

Revision History		
Revision	Description	Date
01	Original Report Release	8 June 2021
02	Amended Sections 3.3.1 and 5.4	11 June 2021

Table of Contents

1	Client Information.....	5
1.1	Applicant.....	5
1.2	Manufacturer.....	5
2	Equipment Under Test (EUT).....	6
2.1	Identification of EUT.....	6
2.2	Description of EUT.....	6
2.3	EUT and Support Equipment.....	6
2.4	Interface Ports on EUT.....	7
2.5	Operating Environment.....	7
2.6	Operating Modes.....	7
2.7	EUT Exercise Software.....	7
2.8	Block Diagram of Test Configuration.....	8
2.9	Modification Incorporated/Special Accessories on EUT.....	8
2.10	Deviation, Opinions Additional Information or Interpretations from Test Standard.....	8
3	Test Specification, Method and Procedures.....	9
3.1	Test Specification.....	9
3.2	Methods & Procedures.....	9
3.3	FCC Part 15, Subpart E.....	9
3.4	Results.....	9
3.5	Test Location.....	9
4	Test Equipment.....	11
4.1	Conducted Emissions at Mains Ports.....	11
4.2	Direct Connect at the Antenna Port Tests.....	11
4.3	Radiated Emissions.....	12
4.4	Equipment Calibration.....	13
4.5	Measurement Uncertainty.....	13
5	Test Results.....	14
5.1	§15.203 Antenna Requirements.....	14
5.2	Conducted Emissions at Mains Ports Data.....	14
5.3	§15.403(i) 26 dB Emissions Bandwidth.....	16
5.4	§15.403(a)(3) Maximum Average Output Power.....	17
5.5	§15.407(b)(7) Spurious Emissions.....	18
5.6	§15.407(a) Maximum Power Spectral Density.....	23

1 Client Information

1.1 Applicant

Company	Ubiquiti Inc. 685 Third Avenue New York, NY 10017 U.S.A.
Contact Name	Mark Feil
Title	Compliance Manager

1.2 Manufacturer

Company	Ubiquiti Inc. 685 Third Avenue New York, NY 10017 U.S.A.
Contact Name	Mark Feil
Title	Compliance Manager

2 Equipment Under Test (EUT)

2.1 Identification of EUT

Brand Name	UniFi
Model Number	U6-Enterprise
Serial Number	68D79A1F0D5A
Dimensions (cm)	22.0 x 22.0 x 4.8

2.2 Description of EUT

The U6-Enterprise is a four-stream WiFi 6 access point that provides up to 2.4 Gbps aggregate radio rate with 2.4 GHz (2x2), 5 GHz (4x4) and 6 GHz (4x4) radios. The U6-Enterprise is designed for indoor use. The U6-Enterprise has an Ethernet port for data transfer and is powered by an 803.2at PoE power adapter. The U6-Enterprise has a Bluetooth management radio to achieve setup and operation.

The table below show the channels used within the different modulation bandwidths.

Band	WiFi Mode	Modulation Bandwidth	Modulation Type	Frequency (MHz)
UNII-3	a	20 MHz	OFDM	5745, 5775, 5825
	n	20 MHz	HT	5745, 5775, 5825
	n	40 MHz	HT	5755, 5775, 5795
	ac	20 MHz	VHT	5745, 5775, 5825
	ac	40 MHz	VHT	5755, 5775, 5795
	ac	80 MHz	VHT	5775
	ax	20 MHz	HE	5745, 5775, 5825
	ax	40 MHz	HE	5755, 5775, 5795
ax	80 MHz	HE	5775	

This report covers the circuitry of the device subject to FCC Part 15, Subpart E. The circuitry of the device subject to FCC Part 15 Subpart B was found to be compliant and is covered under a separate Unified Compliance Laboratory test report.

2.3 EUT and Support Equipment

The EUT and support equipment used during the test are listed below.

Brand Name Model Number Serial Number	Description	Name of Interface Ports / Interface Cables
BN: UniFi	WiFi Access Point	See Section 2.4

MN: U6-Enterprise SN: 68D79A1F0D5A		
BN: Ubiquiti MN: UPOE-at SN: N/A	PoE Power Adapter	Shielded or Un-Shielded Cat 5e cable (Note 2)
BN: Dell MN: XPS 13 SN: N/A	Laptop Personal Computer	Shielded or Un-Shielded Cat 5e cable (Note 2)

Notes: (1) EUT

(2) Interface port connected to EUT (See Section 2.4)

The support equipment listed above was not modified in order to achieve compliance with this standard.

2.4 Interface Ports on EUT

Name of Ports	No. of Ports Fitted to EUT	Cable Description/Length
PoE	1	Shielded or Un-Shielded Cat 5e Cable/> 3 meters
Data	1	Shielded or Un-Shielded Cat 5e Cable/> 3 Meters

2.5 Operating Environment

Power Supply	120 Volts ac to 48 Volts PoE Power
AC Mains Frequency	60 Hz
Temperature	21.9 – 26.2 °C
Humidity	21.3 – 29.8 %
Barometric Pressure	1021 mBar

2.6 Operating Modes

The U6-Enterprise was tested using test software in order to enable a constant transmission of over 98%. All emission modes of 802.11 a/n/ac/ax were investigated. All measurements are reported with the worst-case mode (802.11ax) unless otherwise stated.

2.7 EUT Exercise Software

EUT firmware version 1.0 was used to operate the transmitter using a constant transmit mode.

2.8 Block Diagram of Test Configuration

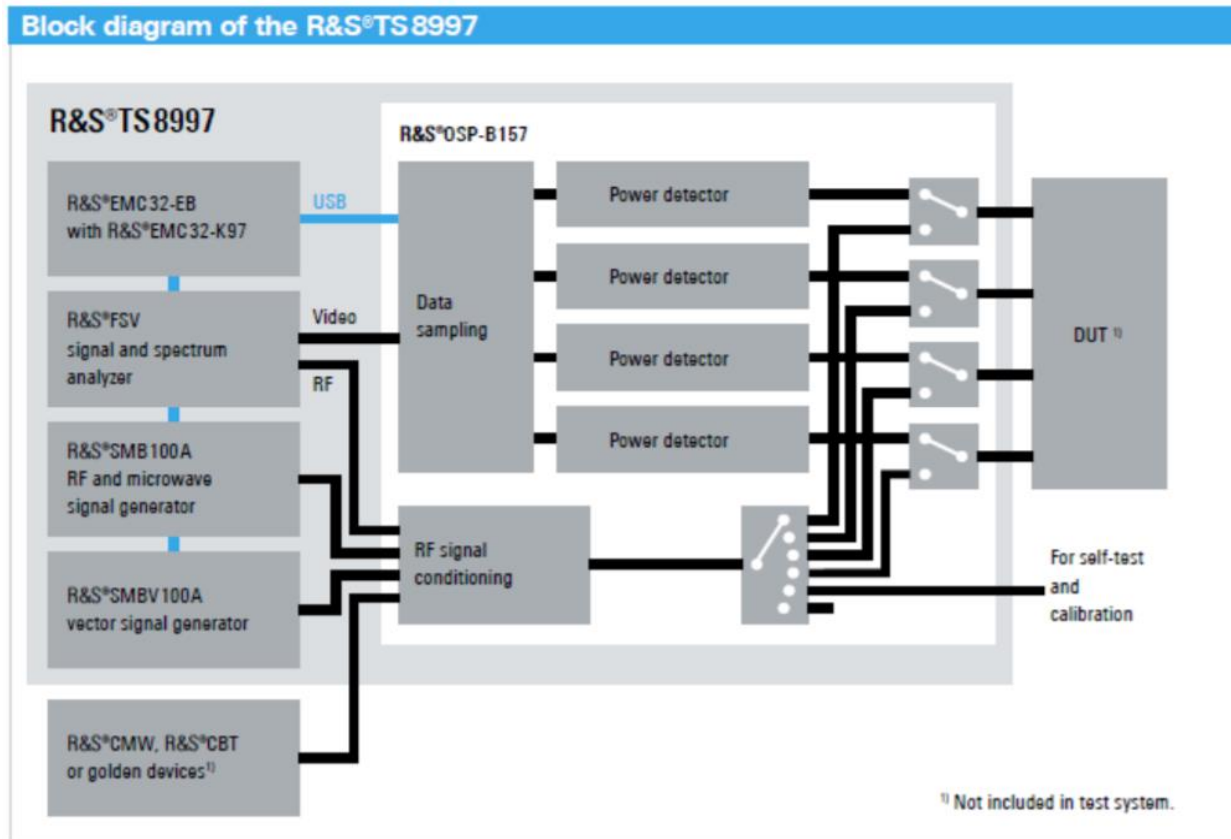

Diagram 1: Test Configuration Block Diagram

2.9 Modification Incorporated/Special Accessories on EUT

There were no modifications made to the EUT during testing to comply with the specification.

2.10 Deviation, Opinions Additional Information or Interpretations from Test Standard

There were no deviations, opinions, additional information or interpretations from the test specification.

3 Test Specification, Method and Procedures

3.1 Test Specification

Title	47 CFR FCC Part 15, Subpart E, Section 15.407 Limits and methods of measurement of radio interference characteristics of Unlicensed National Information Infrastructure Devices
Purpose of Test	The tests were performed to demonstrate initial compliance

3.2 Methods & Procedures

3.2.1 47 CFR FCC Part 15 Section 15.407

See test standard for details.

3.3 FCC Part 15, Subpart E

3.3.1 Summary of Tests

FCC Section	ISED Section	Environmental Phenomena	Frequency Range (MHZ)	Result
15.407(a)	N/A	Antenna requirements	Structural Requirement	Compliant
15.407(b)	RSS-Gen	Conducted Disturbance at Mains Port	0.15 to 30	Compliant
15.407(c)	RSS-247 §6.2.2, §6.2.3	Bandwidth Requirement	5745 to 5825	Compliant
15.407(e)	RSS-247 §6.2.2, §6.2.3	Peak Output Power	5745 to 5825	Compliant
15.407(f)	RSS-247 §6.2.2, §6.2.3	Antenna Conducted Spurious Emissions	0.009 to 40000	N/A
15.407(g)	RSS-247 §6.2.2, §6.2.3	Radiated Spurious Emissions	0.009 to 40000	Compliant
15.407(h)	RSS-247 §6.2.2, §6.2.3	Peak Power Spectral Density	5745 to 5825	Compliant

The testing was performed according to the procedures in ANSI C63.10-2013, KDB 789033 and 47 CFR Part 15. Where applicable, KDB 662911 was followed to sum required measurements.

3.4 Results

In the configuration tested, the EUT complied with the requirements of the specification.

3.5 Test Location

Testing was performed at the Unified Compliance Laboratory 3-Meter and 10-Meter chambers located at 427 West 12800 South, Draper, UT 84020. Unified Compliance Laboratory is accredited by National Voluntary Laboratory Accreditation Program (NVLAP); NVLAP Code 600241-0 which is effective until

30 June 2021. This site has also been registered with Innovations, Science and Economic Development (ISED) department as was accepted under Appendix B, Phase 1 procedures of the APEC Tel MRA for Canadian recognition. ISED No.: 25346, effective until June 30, 2021. Unified Compliance Laboratory has been assigned Conformity Assessment Number US0223 by ISED.

4 Test Equipment

4.1 Conducted Emissions at Mains Ports

Type of Equipment	Manufacturer	Model Number	Asset Number	Date of Last Calibration	Due Date of Calibration
EMI Receiver	AFJ	FFT3010	UCL-2500	9/18/2020	9/17/2021
LISN	AFJ	LS16C/10	UCL-2512	5/26/2020	5/26/2022
Cat6 ISN	Teseq	ISN T8-Cat6	UCL-2971	5/18/2020	5/18/2022
ISN	Teseq	ISN T800	UCL-2974	6/1/2020	6/1/2021
LISN	Com-Power	LIN-120C	UCL-2612	5/19/2021	5/19/2022
AC Power Source	Laplace Instruments	AC1000A	UCL-2857	N/A	N/A
Test Software	UCL	Revision 1	UCL-3107	N/A	N/A

Table 1: List of equipment used for Conducted Emissions Testing at Mains Port

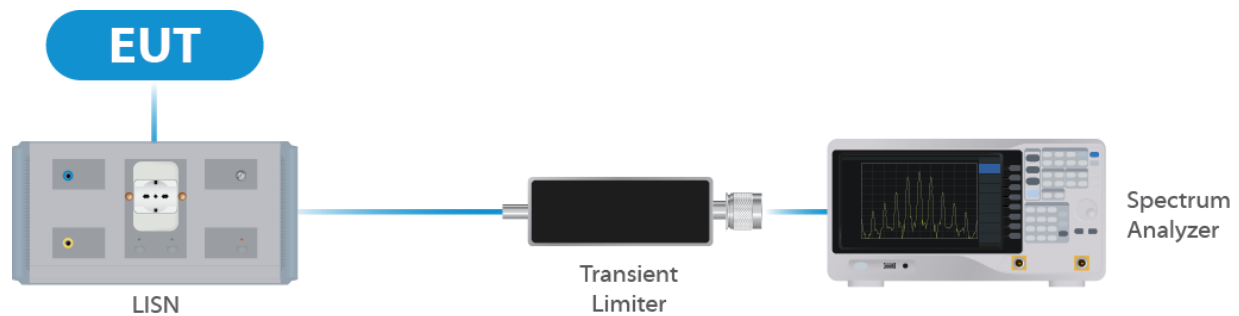

Figure 1: Conducted Emissions Test

4.2 Direct Connect at the Antenna Port Tests

Type of Equipment	Manufacturer	Model Number	Asset Number	Date of Last Calibration	Due Date of Calibration
Spectrum Analyzer	R&S	FSV40	UCL-2861	8/24/2020	8/24/2021
Signal Generator	R&S	SMB100A	UCL-2864	N/A	N/A
Vector Signal Generator	R&S	SMBV100A	UCL-2873	N/A	N/A
Switch Extension	R&S	OSP-B157WX	UCL-2867	9/8/2020	9/8/2021
Switch Extension	R&S	OSP-150W	UCL-2870	3/3/2021	3/3/2022

Table 2: List of equipment used for Direct Connect at the Antenna Port

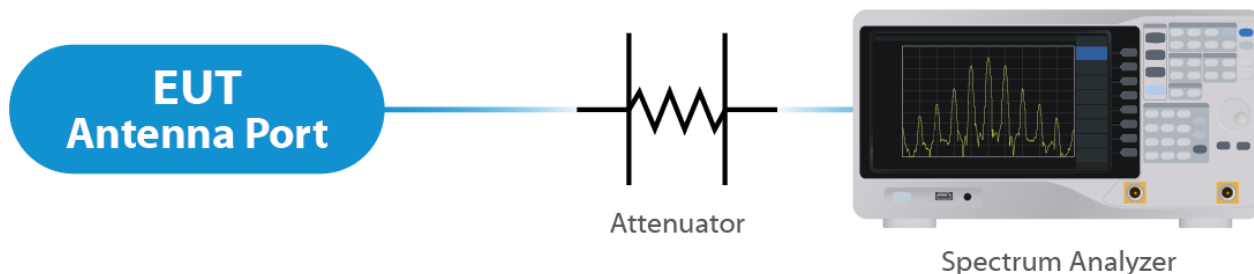

Figure 2: Direct Connect at the Antenna Port Test

4.3 Radiated Emissions

Type of Equipment	Manufacturer	Model Number	Asset Number	Date of Last Calibration	Due Date of Calibration
EMI Receiver	Keysight	N9038A	UCL-2778	6/1/2020	8/1/2021
Pre-Amplifier 9 kHz – 1 GHz	Sonoma Instruments	310N	UCL-2889	9/10/2020	9/10/2021
Double Ridge Horn Antenna	Scwarzbeck	BBHA 9120D	UCL-3065	7/8/2020	7/8/2021
Log Periodic	Scwarzbeck	STLP 9129	UCL-3068	11/16/2020	11/16/2021
15 - 40 GHz Horn Antenna	Scwarzbeck	BBHA 9170	UCL-2487	5/21/2020	5/21/2022
1 – 18 GHz Amplifier	Com-Power	PAM 118A	UCL-3833	9/29/2020	9/29/2021
Test Software	UCL	Revision 1	UCL-3108	N/A	N/A

Table 3:List of equipment used for Radiated Emissions

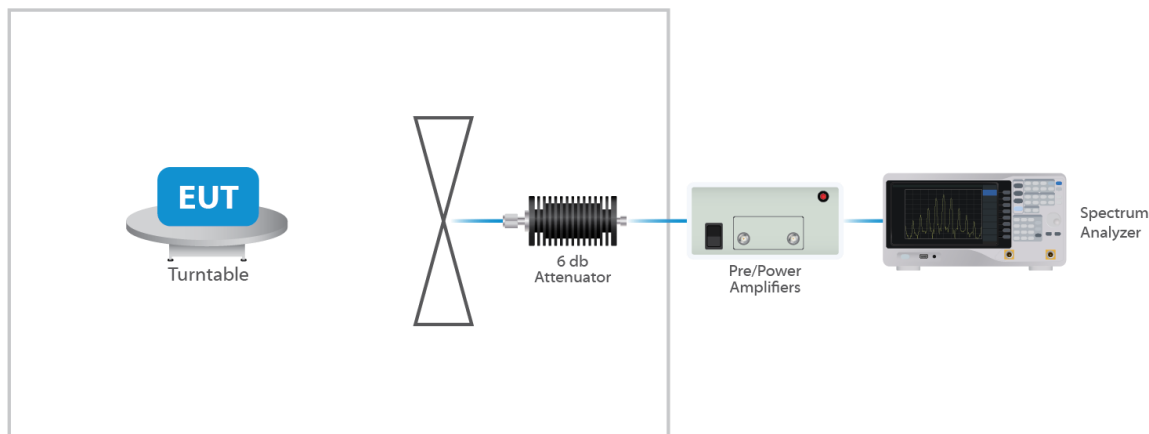

Figure 3: Radiated Emissions Test

4.4 Equipment Calibration

All applicable equipment is calibrated using either an independent calibration laboratory or Unified Compliance Laboratory personnel at intervals defined in ANSI C63.4:2014 following outlined calibration procedures. All measurement instrumentation is traceable to the National Institute of Standards and Technology (NIST). Supporting documentation relative to traceability is on file and is available for examination upon request.

4.5 Measurement Uncertainty

Test	Uncertainty (\pm dB)	Confidence (%)
Conducted Emissions	1.44	95
Radiated Emissions (9 kHz to 30 MHz)	2.50	95
Radiated Emissions (30 MHz to 1 GHz)	4.38	95
Radiated Emissions (1 GHz to 18 GHz)	4.37	95
Radiated Emissions (18 GHz to 40 GHz)	3.93	95
Direct Connect Tests	K Factor	Value
Emissions Bandwidth	2	2.0%
Output Power	2	1.0 dB
Peak Power Spectral Density	2	1.3 dB
Band Edge	2	0.8 dB
Transmitter Spurious Emissions	2	1.8 dB

5 Test Results

5.1 §15.203 Antenna Requirements

The EUT uses an integral. The Maximum gain of the antenna is 5.3 dBi. The antenna is not user replaceable.

Results

The EUT complied with the specification

5.2 Conducted Emissions at Mains Ports Data

5.2.1 Line

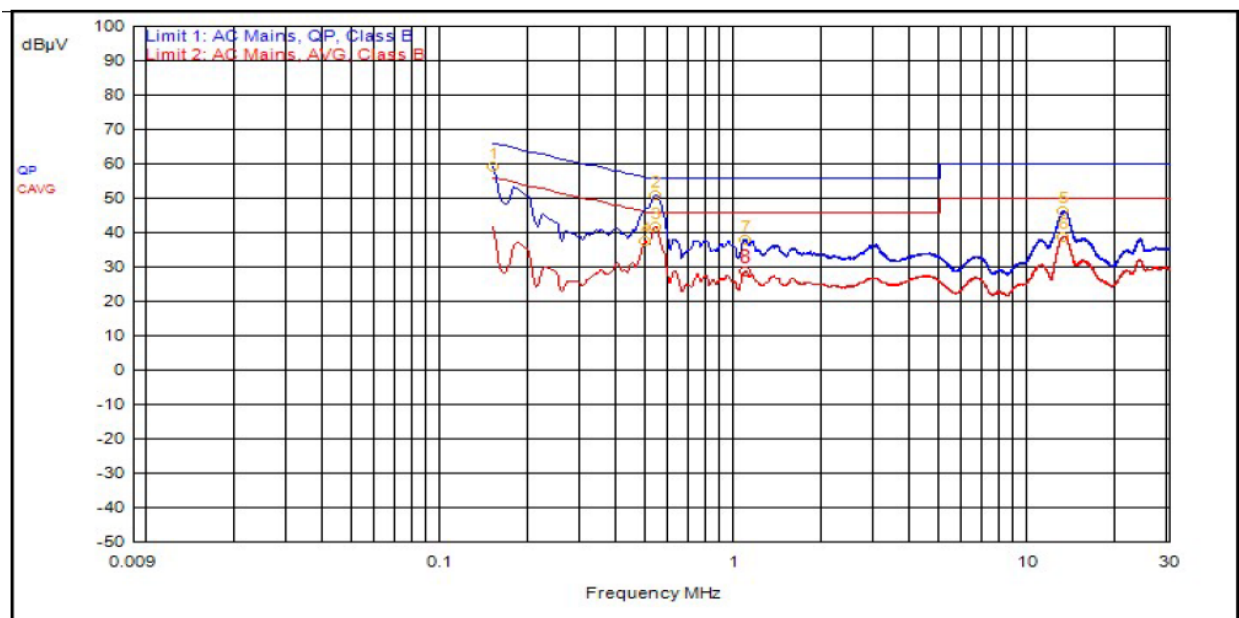

ID	Frequency	Probe	Cable	Atten.	Detector	Meter Read	Meas Level	Limit 1	Limit 1 Dist.	Limit 2	Limit 2 Dist.
2	534,000kHz	12.4			QPeak	38.3	50.7	56.0	-5.3		
1	150,000kHz	12.4			QPeak	46.8	59.2	66.0	-6.8		
5	13.041MHz	12.4			QPeak	33.7	46.2	60.0	-13.8		
7	1.083MHz	12.4			QPeak	25.4	37.8	56.0	-18.2		
3	537,000kHz	12.4			C_AVG	29.2	41.6			46.0	-4.4
4	495,000kHz	12.4			C_AVG	25.1	37.5			46.1	-8.6
6	13.041MHz	12.4			C_AVG	26.4	38.8			50.0	-11.2
8	1.083MHz	12.4			C_AVG	16.3	28.7			46.0	-17.3

5.2.2 Neutral

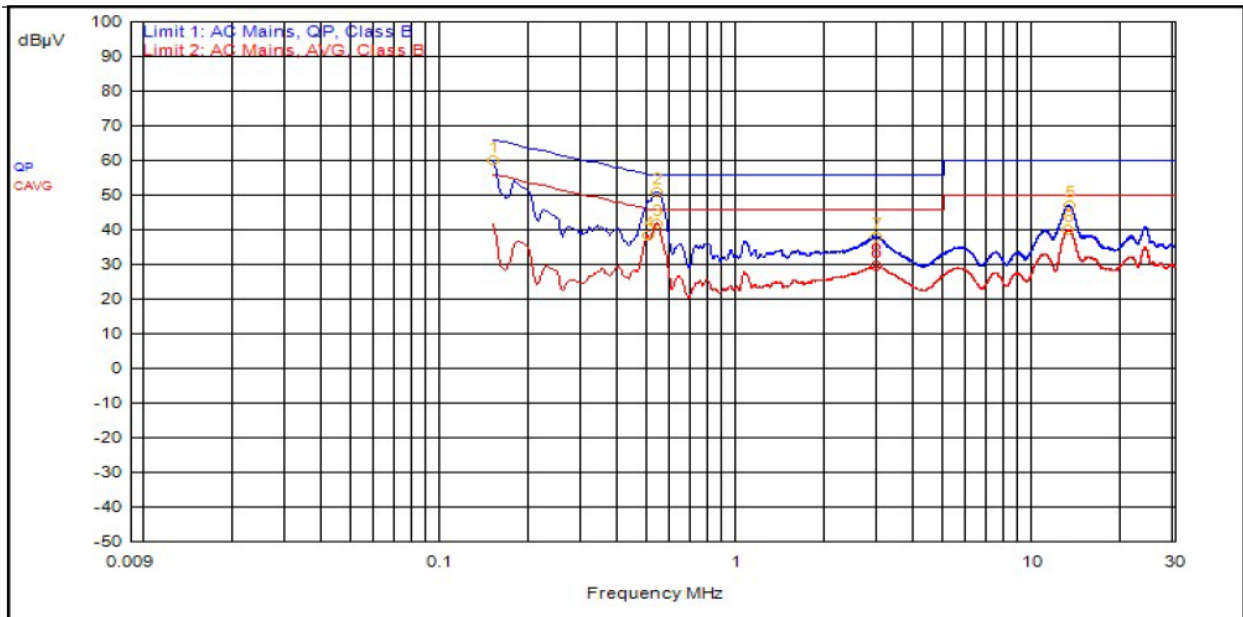

ID	Frequency	Probe	Cable	Atten.	Detector	Meter Read	Meas Level	Limit 1	Limit 1 Dist.	Limit 2	Limit 2 Dist.
2	531,000kHz	12.4			QPeak	38.4	50.8	56.0	-5.2		
1	150,000kHz	12.4			QPeak	47.5	59.9	66.0	-6.1		
5	13.080MHz	12.4			QPeak	34.5	46.9	60.0	-13.1		
7	2.940MHz	12.3			QPeak	25.7	38.0	56.0	-18.0		
3	531,000kHz	12.4			C_AVG	29.4	41.8			46.0	-4.2
4	498,000kHz	12.4			C_AVG	25.9	38.3			46.0	-7.8
6	12.963MHz	12.4			C_AVG	27.5	39.9			50.0	-10.1
8	2.928MHz	12.3			C_AVG	17.2	29.5			46.0	-16.5

Result

The EUT complied with the specification limit.

5.3 §15.403(i) 26 dB Emissions Bandwidth

Nominal BW (MHz)	Frequency (MHz)	99% Bandwidth (MHz)	26 dB Bandwidth (MHz)
20	5745	36.6	83.1
20	5775	36.3	87.6
20	5825	34.9	56.0
40	5755	63.5	107.4
40	5775	69.0	128.6
40	5795	66.75	116.4
80	5775	96.0	166.0

Result

The 26 dB bandwidths are reported for information purposes. Please see Annex for all bandwidth measurements.

5.4 §15.403(a)(3) Maximum Average Output Power

The maximum average RF conducted output power measured for this device was 27.57 dBm or 571.48 mW. The limit is 30 dBm, or 1 Watt when using antennas with 6 dBi or less gain.. The antenna has a gain of 5.3 dBi.

Modulation (BW)	Frequency (MHz)	Data Rate	TP Setting	Conducted Output Power *	Measured EIRP	Measured PSD
OFDM 20	5745	Mcs0	49	27.29	32.6	9.78
OFDM 20	5775	Mcs0	49	27.08	32.4	9.79
OFDM 20	5825	Mcs0	43	25.71	31.0	8.1
HT 20	5745	Mcs0	49	27.53	32.8	9.1
HT 20	5775	Mcs0	49	27.25	32.6	8.8
HT 20	5825	Mcs0	43	25.70	31.0	7.2
HT 40	5755	Mcs0	40	25.44	30.7	4.1
HT 40	5775	Mcs0	41	25.85	31.2	4.52
HT 40	5795	Mcs0	41	25.69	31.0	4.5
VHT 20	5745	Mcs0	49	27.57	32.9	9.09
VHT 20	5775	Mcs0	49	27.23	32.5	8.76
VHT 20	5825	Mcs0	43	25.68	31.0	7.19
VHT 40	5755	Mcs0	40	25.40	30.7	3.98
VHT 40	5775	Mcs0	41	25.81	31.1	4.35
VHT 40	5795	Mcs0	41	25.65	31.0	4.37
VHT 80	5775	Mcs0	38	24.01	29.3	-0.55
HE 20	5745	Mcs0	44	26.63	31.9	8.32
HE 20	5775	Mcs0	49	27.21	32.5	8.57
HE 20	5825	Mcs0	43	25.81	31.1	7.22
HE 40	5755	Mcs0	40	25.44	30.7	3.88
HE 40	5775	Mcs0	41	25.83	31.1	4.18
HE 40	5795	Mcs0	41	25.70	31.0	4.19
HE 80	5775	Mcs0	38	24.22	29.5	-0.37

Result

In the configuration tested, the maximum average RF outpower was less than 1 watt; therefore, the EUT complied with the requirements of the specification (see spectrum analyzer plots in attached Annex).

* Gated EIRP shown in the Annex is the conducted measurement

5.5 §15.407(b)(7) Spurious Emissions

5.5.1 Radiated Spurious Emissions in the Restricted Bands of § 15.205

The EUT uses various power settings based on the channel in use. In order to reduce test time, the radiated spurious emissions at the lowest, middle, and highest channel were measured at the maximum power of TP49.

Result

All emissions in the restricted bands of § 15.205 met the limits specified in § 15.209; therefore, the EUT complies with the specification. See Annex for Conducted Band edge plots.

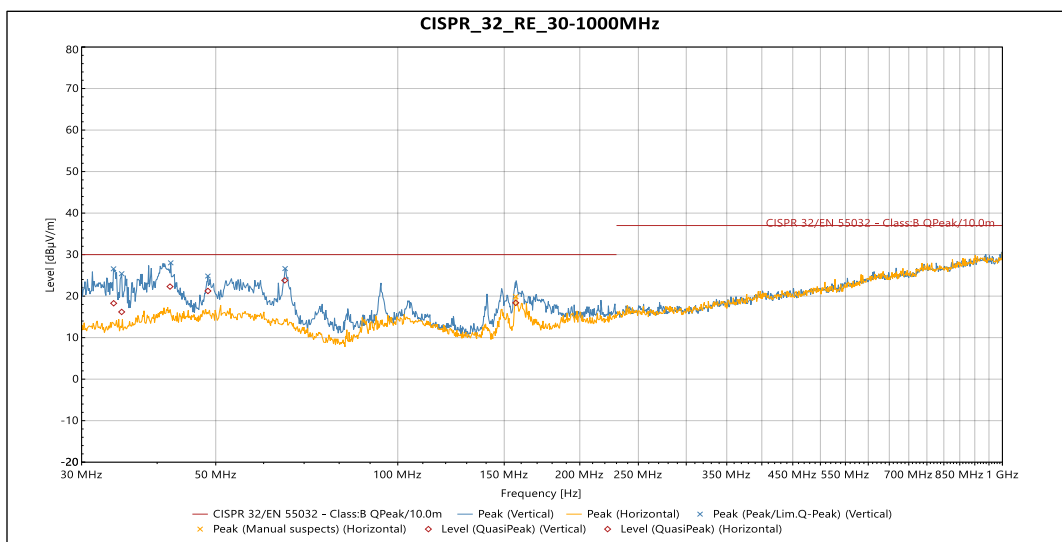

Vertical

Source	Frequency	Level (dBµV/m)	Limit (dBµV/m)	Margin	Azimuth (°)	Height	Pol.	Correction (dB)
QuasiPeak	33.896 MHz	18.279	30	-11.721	81	1.106	Vertical	-15.184
QuasiPeak	34.945 MHz	16.188	30	-13.812	319	1.946	Vertical	-14.833
QuasiPeak	42.009 MHz	22.297	30	-7.703	73	2.164	Vertical	-12.832
QuasiPeak	48.534 MHz	21.24	30	-8.76	20	2.62	Vertical	-12.359
QuasiPeak	65.031 MHz	23.786	30	-6.214	108	2.835	Vertical	-14.684

Horizontal

Source	Frequency	Level (dBµV/m)	Limit (dBµV/m)	Margin	Azimuth (°)	Height	Pol.	Correction (dB)
QuasiPeak	156.72 MHz	18.377	30	-11.623	235	3.995	Horizontal	-17.354

Table 4: Radiated Emissions – 30 – 1000 MHz

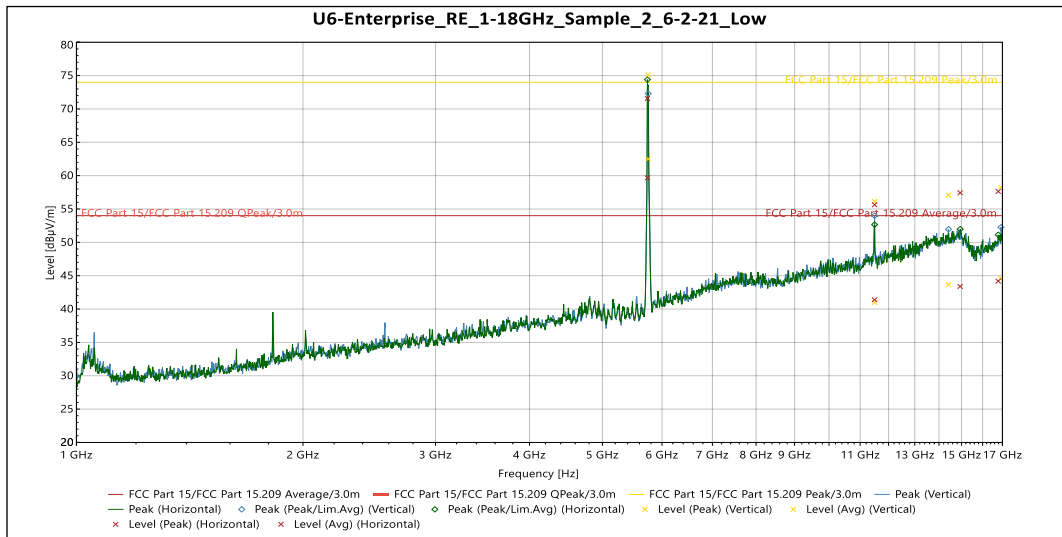
Vertical

Source	Frequency	Level (dBµV/m)	Limit (dBµV/m)	Margin (dB)	Azimuth (°)	Height (m)	Pol.	Correction (dB)
Peak	11.497 GHz	56.127	74	-17.873	350	3.102	Vertical	11.391
Peak	14.413 GHz	57.085	74	-16.915	98	3.456	Vertical	14.543
Peak	16.924 GHz	58.25	74	-15.75	145	2.747	Vertical	16.5

Source	Frequency	Level (dBµV/m)	Limit (dBµV/m)	Margin (dB)	Azimuth (°)	Height (m)	Pol.	Correction (dB)
Avg	11.497 GHz	40.992	54	-13.008	350	3.102	Vertical	11.391
Avg	14.413 GHz	43.673	54	-10.327	98	3.456	Vertical	14.543
Avg	16.924 GHz	44.603	54	-9.397	145	2.747	Vertical	16.5

Horizontal

Source	Frequency	Level (dBµV/m)	Limit (dBµV/m)	Margin (dB)	Azimuth (°)	Height (m)	Pol.	Correction (dB)
Peak	11.498 GHz	55.644	74	-18.356	40	2.399	Horizontal	11.399
Peak	14.939 GHz	57.431	74	-16.569	17	1.817	Horizontal	14.389
Peak	16.783 GHz	57.629	74	-16.371	239	1.634	Horizontal	16.019

Source	Frequency	Level (dBµV/m)	Limit (dBµV/m)	Margin (dB)	Azimuth (°)	Height (m)	Pol.	Correction (dB)
Avg	11.498 GHz	41.39	54	-12.61	40	2.399	Horizontal	11.399
Avg	14.939 GHz	43.385	54	-10.615	17	1.817	Horizontal	14.389
Avg	16.783 GHz	44.183	54	-9.817	239	1.634	Horizontal	16.019

Table 5: Transmitting on the Lowest Frequency 5745 MHz – 1 – 17 GHz

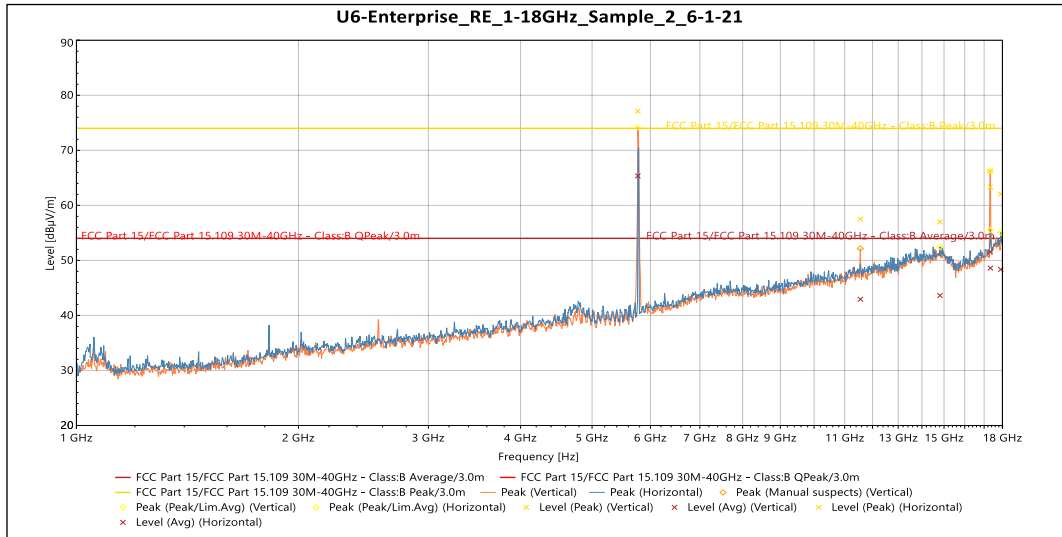

Vertical

Source	Frequency	Level (dBµV/m)	Limit (dBµV/m)	Margin (dB)	Azimuth (°)	Height (m)	Pol.	Correction (dB)
Peak	11.555 GHz	57.472	74	-16.528	339	2.351	Vertical	11.551
Peak	17.321 GHz	66.2	74	-7.8	40	1.814	Vertical	16.529

Source	Frequency	Level (dBµV/m)	Limit (dBµV/m)	Margin (dB)	Azimuth (°)	Height (m)	Pol.	Correction (dB)
Avg	11.555 GHz	42.936	54	-11.064	339	2.351	Vertical	11.551
Avg	17.321 GHz	51.52	54	-2.48	40	1.814	Vertical	16.529

Horizontal

Source	Frequency	Level (dBµV/m)	Limit (dBµV/m)	Margin (dB)	Azimuth (°)	Height (m)	Pol.	Correction (dB)
Peak	14.812 GHz	56.972	74	-17.028	278	2.357	Horizontal	14.63
Peak	17.338 GHz	63.328	74	-10.672	40	2.363	Horizontal	16.568
Peak	17.907 GHz	62.066	74	-11.934	116	3.973	Horizontal	18.32

Source	Frequency	Level (dBµV/m)	Limit (dBµV/m)	Margin (dB)	Azimuth (°)	Height (m)	Pol.	Correction (dB)
Avg	14.812 GHz	43.621	54	-10.379	278	2.357	Horizontal	14.63
Avg	17.338 GHz	48.59	54	-5.41	40	2.363	Horizontal	16.568
Avg	17.907 GHz	48.363	54	-5.637	116	3.973	Horizontal	18.32

Table 6: Transmitting on the Middle Frequency 5775 MHz – 1 – 17 GHz

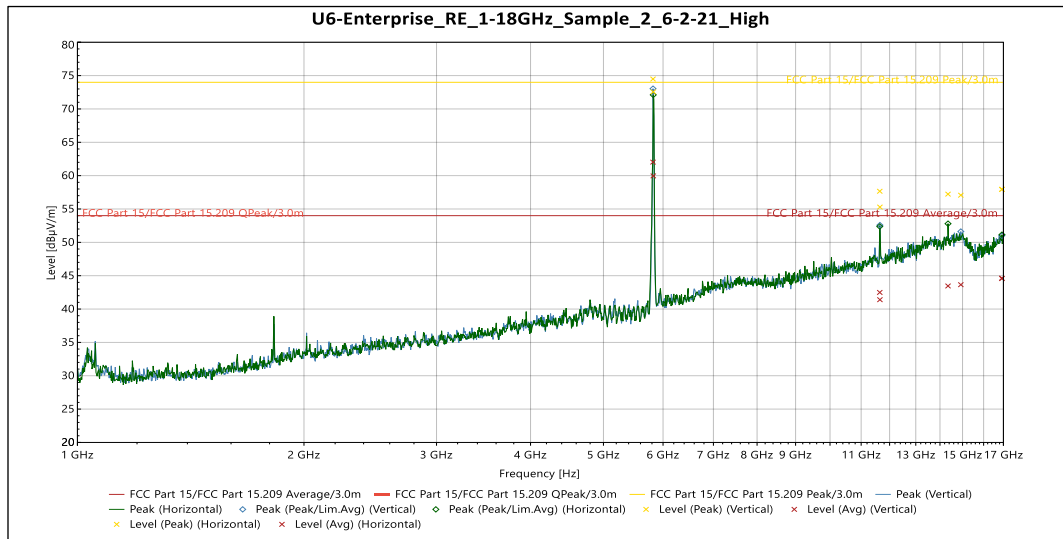

Vertical

Source	Frequency	Level (dBµV/m)	Limit (dBµV/m)	Margin (dB)	Azimuth (°)	Height (m)	Pol.	Correction (dB)
Peak	11.65 GHz	55.288	74	-18.712	325	2.578	Vertical	11.681
Peak	14.923 GHz	57.066	74	-16.934	198	2.53	Vertical	14.691
Peak	16.918 GHz	57.925	74	-16.075	59	3.129	Vertical	16.547

Source	Frequency	Level (dBµV/m)	Limit (dBµV/m)	Margin (dB)	Azimuth (°)	Height (m)	Pol.	Correction (dB)
Avg	11.65 GHz	41.398	54	-12.602	325	2.578	Vertical	11.681
Avg	14.923 GHz	43.648	54	-10.352	198	2.53	Vertical	14.691
Avg	16.918 GHz	44.633	54	-9.367	59	3.129	Vertical	16.547

Horizontal

Source	Frequency	Level (dBµV/m)	Limit (dBµV/m)	Margin (dB)	Azimuth (°)	Height (m)	Pol.	Correction (dB)
Peak	11.645 GHz	57.662	74	-16.338	57	2.578	Horizontal	11.658
Peak	14.349 GHz	57.226	74	-16.774	267	2.019	Horizontal	14.449
Peak	16.924 GHz	57.961	74	-16.039	175	3.254	Horizontal	16.5

Source	Frequency	Level (dBµV/m)	Limit (dBµV/m)	Margin (dB)	Azimuth (°)	Height (m)	Pol.	Correction (dB)
Avg	11.645 GHz	42.495	54	-11.505	57	2.578	Horizontal	11.658
Avg	14.349 GHz	43.455	54	-10.545	267	2.019	Horizontal	14.449
Avg	16.924 GHz	44.566	54	-9.434	175	3.254	Horizontal	16.5

Table 7: Transmitting on the Highest Frequency 5825 MHz – 1 – 17 GHz

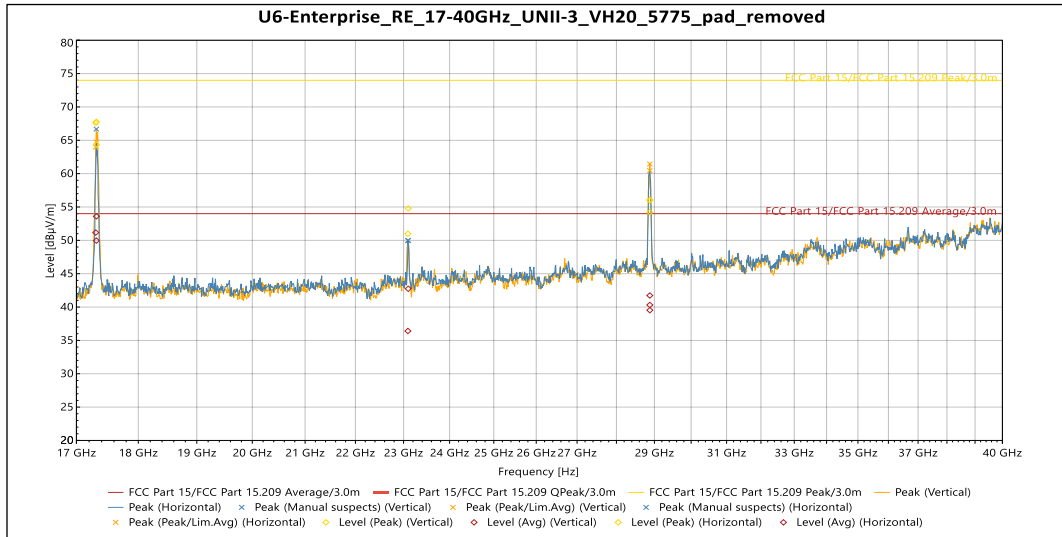

Vertical

Source	Frequency	Level (dBµV/m)	Limit (dBµV/m)	Margin (dB)	Azimuth (°)	Pol.	Correction (dB)
Peak	17.306 GHz	67.602	74	-6.398	358	Vertical	-5.781
Peak	17.316 GHz	67.771	74	-6.229	24	Vertical	-5.887
Peak	23.1 GHz	54.794	74	-19.206	4	Vertical	-5.562
Peak	28.877 GHz	54.224	74	-19.776	345	Vertical	-4.845
Peak	28.878 GHz	55.973	74	-18.027	352	Vertical	-4.845

Source	Frequency	Level (dBµV/m)	Limit (dBµV/m)	Margin (dB)	Azimuth (°)	Pol.	Correction (dB)
Avg	17.306 GHz	51.174	54	-2.826	358	Vertical	-5.781
Avg	17.316 GHz	53.602	54	-0.398	24	Vertical	-5.887
Avg	23.1 GHz	42.744	54	-11.256	4	Vertical	-5.562
Avg	28.877 GHz	40.306	54	-13.694	345	Vertical	-4.845
Avg	28.878 GHz	39.533	54	-14.467	352	Vertical	-4.845

Horizontal

Source	Frequency	Level (dBµV/m)	Limit (dBµV/m)	Margin (dB)	Azimuth (°)	Pol.	Correction (dB)
Peak	17.316 GHz	64.327	74	-9.673	22	Horizontal	-5.887
Peak	23.093 GHz	50.976	74	-23.024	32	Horizontal	-5.334
Peak	28.877 GHz	56.073	74	-17.927	359	Horizontal	-4.845

Source	Frequency	Level (dBµV/m)	Limit (dBµV/m)	Margin (dB)	Azimuth (°)	Pol.	Correction (dB)
Avg	17.316 GHz	49.961	54	-4.039	22	Horizontal	-5.887
Avg	23.093 GHz	36.408	54	-17.592	32	Horizontal	-5.334
Avg	28.877 GHz	41.729	54	-12.271	359	Horizontal	-4.845

Table 8: Transmitting on the Middle Frequency 5775 MHz – 17 – 40 GHz (Worse Case)

5.6 §15.407(a) Maximum Power Spectral Density

The maximum average power spectral density conducted from the intentional radiator of the antenna shall not be greater than 30 dBm in any 500 kHz band during any time interval of continuous transmission. Results of this testing are summarized.

Modulation (BW)	Frequency (MHz)	Data Rate	TP Setting	Measured PSD
OFDM 20	5745	Mcs0	49	9.78
OFDM 20	5775	Mcs0	49	9.79
OFDM 20	5825	Mcs0	43	8.1
HT 20	5745	Mcs0	49	9.1
HT 20	5775	Mcs0	49	8.8
HT 20	5825	Mcs0	43	7.2
HT 40	5755	Mcs0	40	4.1
HT 40	5775	Mcs0	41	4.52
HT 40	5795	Mcs0	41	4.5
VHT 20	5745	Mcs0	49	9.09
VHT 20	5775	Mcs0	49	8.76
VHT 20	5825	Mcs0	43	7.19
VHT 40	5755	Mcs0	50	3.98
VHT 40	5775	Mcs0	41	4.35
VHT 40	5795	Mcs0	41	4.37
VHT 80	5775	Mcs0	38	-0.55
HE 20	5745	Mcs0	44	8.32
HE 20	5775	Mcs0	49	8.57
HE 20	5825	Mcs0	43	7.22
HE 40	5755	Mcs0	40	3.88
HE 40	5775	Mcs0	41	4.18
HE 40	5795	Mcs0	41	4.19
HE 80	5775	Mcs0	38	-0.37

Result

The maximum average power spectral density was less than the limit of 30 dBm; therefore, the EUT complies with the specification.

-- End of Test Report --