



427 West 12800 South
 Draper, UT 84020

Test Report Certification

FCC ID	SWX-U6EP
ISED ID	6545A-U6EP
Equipment Under Test	U6-Enterprise
Test Report Serial Number	TR6129_02
Date of Test(s)	18 – 25 May 2021
Report Issue Date	2 June 2021

Test Specification	Applicant
47 CFR FCC Part 15, Subpart E	Ubiquiti Inc. 685 Third Avenue New York, NY 10019 U.S.A.



NVLAP LAB CODE 600241-0

Certification of Engineering Report

This report has been prepared by Unified Compliance Laboratory (UCL) to document compliance of the device described below with the requirement of Federal Communication Commissions (FCC) Part 15, Subpart E. This report may be reproduced in full. Partial reproduction of this report may only be made with the written consent of the laboratory. The results in this report apply only to the sample tested.

Applicant	Ubiquiti Inc.
Manufacturer	Ubiquiti Inc.
Brand Name	UniFi
Model Number	U6-Enterprise
FCC ID	SWX-U6EP
ISED ID	6545A-U6EP

On this 2nd day of June 2021, I individually and for Unified Compliance Laboratory certify that the statements made in this engineering report are true, complete, and correct to the best of my knowledge and are made in good faith.

Although NVLAP has accredited the Unified Compliance Laboratory testing facilities, this report must not be used to claim product certification, approval, or endorsement by NVLAP, NIST or any agency of the U.S. federal government.

Unified Compliance Laboratory



Written By: Joseph W. Jackson



Reviewed By: Alex Macon

Revision History		
Revision	Description	Date
01	Original Report Release	2 June 2021
02	Amended Sections 3.3.1 and 5.4	11 June 2021

Table of Contents

1	Client Information.....	5
1.1	Applicant.....	5
1.2	Manufacturer.....	5
2	Equipment Under Test (EUT).....	6
2.1	Identification of EUT.....	6
2.2	Description of EUT.....	6
2.3	EUT and Support Equipment.....	7
2.4	Interface Ports on EUT.....	7
2.5	Operating Environment.....	7
2.6	Operating Modes.....	7
2.7	EUT Exercise Software.....	8
2.8	Block Diagram of Test Configuration.....	8
2.9	Modification Incorporated/Special Accessories on EUT.....	8
2.10	Deviation, Opinions Additional Information or Interpretations from Test Standard.....	8
3	Test Specification, Method and Procedures.....	9
3.1	Test Specification.....	9
3.2	Methods & Procedures.....	9
3.3	FCC Part 15, Subpart E.....	9
3.4	Results.....	9
3.5	Test Location.....	9
4	Test Equipment.....	11
4.1	Conducted Emissions at Mains Ports.....	11
4.2	Direct Connect at the Antenna Port Tests.....	11
4.3	Radiated Emissions.....	12
4.4	Equipment Calibration.....	13
4.5	Measurement Uncertainty.....	13
5	Test Results.....	14
5.1	§15.203 Antenna Requirements.....	14
5.2	Conducted Emissions at Mains Ports Data.....	14
5.3	§15.403(i) 26 dB Emissions Bandwidth.....	16
5.4	§15.403(a)(1) Maximum Average Output Power.....	17
5.5	§15.407(b) Spurious Emissions.....	18
5.6	§15.407(a) Maximum Power Spectral Density.....	33

1 Client Information

1.1 Applicant

Company	Ubiquiti Inc. 685 Third Avenue New York, NY 10017 U.S.A.
Contact Name	Mark Feil
Title	Compliance Manager

1.2 Manufacturer

Company	Ubiquiti Inc. 685 Third Avenue New York, NY 10017 U.S.A.
Contact Name	Mark Feil
Title	Compliance Manager

2 Equipment Under Test (EUT)

2.1 Identification of EUT

Brand Name	UniFi
Model Number	U6-Enterprise
Serial Number	68D79A1F0D5A
Dimensions (cm)	22.0 x 22.0 x 4.8

2.2 Description of EUT

The U6-Enterprise is a four-stream WiFi 6 access point that provides up to 2.4 Gbps aggregate radio rate with 2.4 GHz (2x2), 5 GHz (4x4) and 6 GHz (4x4) radios. The U6-Enterprise is designed for indoor use. The U6-Enterprise has an Ethernet port for data transfer and is powered by an 803.2at PoE power adapter. The U6-Enterprise has a Bluetooth management radio to achieve setup and operation. The table below show the channels used within the different modulation bandwidths.

Band	WiFi Mode	Modulation Bandwidth	Modulation Type	Frequency (MHz)
UNII-1	a	20 MHz	OFDM	5180, 5200, 5210, 5240
	n	20 MHz	HT	5180, 5200, 5210, 5240
	n	40 MHz	HT	5190, 5230
	ac	20 MHz	VHT	5180, 5200, 5210, 5240
	ac	40 MHz	VHT	5190, 5230
	ac	80 MHz	VHT	5210
	ax	20 MHz	HE	5180, 5200, 5210, 5240
	ax	40 MHz	HE	5190, 5230
	ax	80 MHz	HE	5210

This report covers the circuitry of the device subject to FCC Part 15, Subpart E. The circuitry of the device subject to FCC Part 15 Subpart B was found to be compliant and is covered under a separate Unified Compliance Laboratory test report.

2.3 EUT and Support Equipment

The EUT and support equipment used during the test are listed below.

Brand Name Model Number Serial Number	Description	Name of Interface Ports / Interface Cables
BN: UniFi MN: U6-Enterprise SN: 68D79A1F0D5A	WiFi Access Point	See Section 2.4
BN: Ubiquiti MN: UPOE-at SN: N/A	PoE Power Adapter	Shielded or Un-Shielded Cat 5e cable (Note 2)
BN: Dell MN: XPS 13 SN: N/A	Laptop Personal Computer	Shielded or Un-Shielded Cat 5e cable (Note 2)

Notes: (1) EUT

(2) Interface port connected to EUT (See Section 2.4)

The support equipment listed above was not modified in order to achieve compliance with this standard.

2.4 Interface Ports on EUT

Name of Ports	No. of Ports Fitted to EUT	Cable Description/Length
PoE	1	Shielded or Un-Shielded Cat 5e Cable/> 3 meters
Data	1	Shielded or Un-Shielded Cat 5e Cable/> 3 Meters

2.5 Operating Environment

Power Supply	120 Volts ac to 48 Volts PoE Power
AC Mains Frequency	60 Hz
Temperature	21.9 – 24.4 °C
Humidity	25.3 – 29.8 %
Barometric Pressure	1023 mBar

2.6 Operating Modes

The U6-Enterprise was tested using test software in order to enable to constant transmission of over 98%. All emission modes of 802.11 a/n/ac/ax were investigated. All measurements are reported with the worst-case mode (802.11ax) unless otherwise stated.

2.7 EUT Exercise Software

EUT firmware version 1.0 was used to operate the transmitter using a constant transmit mode.

2.8 Block Diagram of Test Configuration

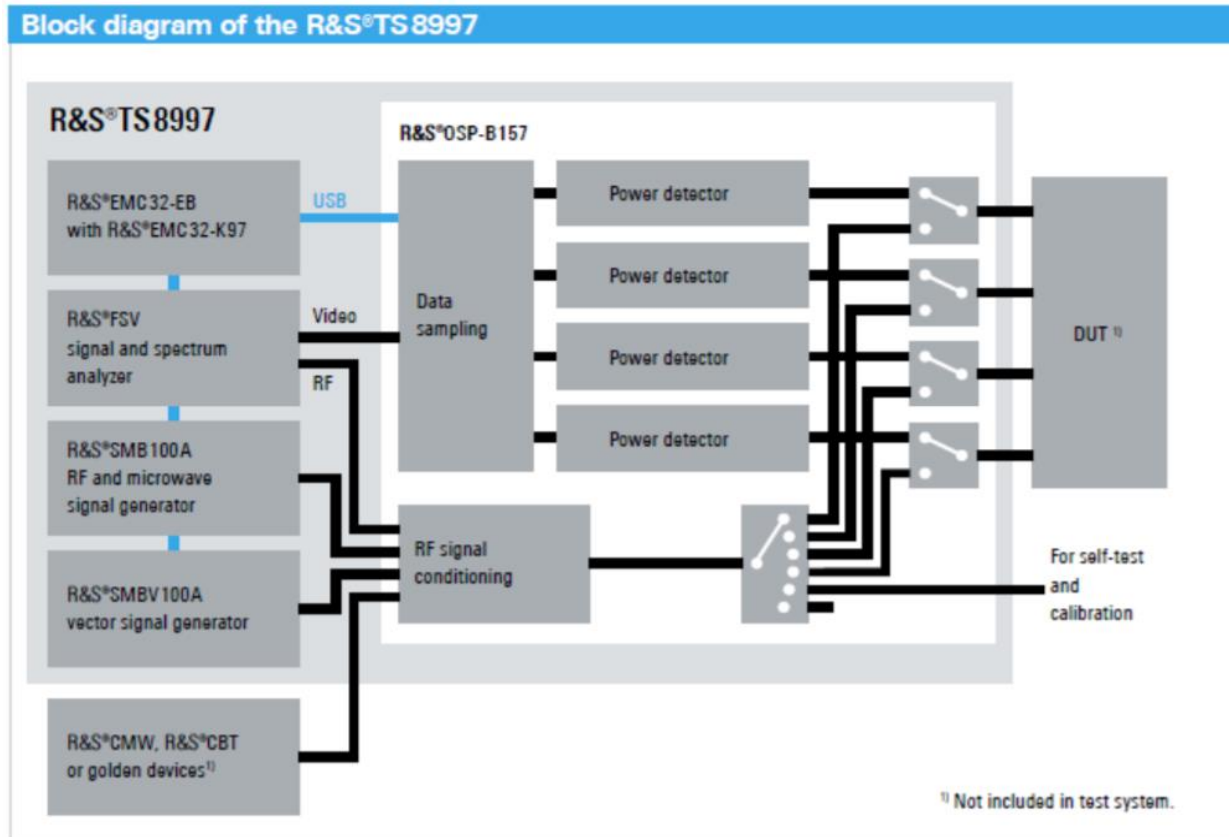

Diagram 1: Test Configuration Block Diagram

2.9 Modification Incorporated/Special Accessories on EUT

There were no modifications made to the EUT during testing to comply with the specification.

2.10 Deviation, Opinions Additional Information or Interpretations from Test Standard

There were no deviations, opinions, additional information or interpretations from the test specification.

3 Test Specification, Method and Procedures

3.1 Test Specification

Title	47 CFR FCC Part 15, Subpart E, Section 15.407 Limits and methods of measurement of radio interference characteristics of Unlicensed National Information Infrastructure Devices
Purpose of Test	The tests were performed to demonstrate initial compliance

3.2 Methods & Procedures

3.2.1 47 CFR FCC Part 15 Section 15.407

See test standard for details.

3.3 FCC Part 15, Subpart E

3.3.1 Summary of Tests

FCC Section	ISED Section	Environmental Phenomena	Frequency Range (MHZ)	Result
15.407(a)	N/A	Antenna requirements	Structural Requirement	Compliant
15.407(b)	RSS-Gen	Conducted Disturbance at Mains Port	0.15 to 30	Compliant
15.407(c)	RSS-247 §6.2.2, §6.2.3	Bandwidth Requirement	5180 to 5250	Compliant
15.407(e)	RSS-247 §6.2.2, §6.2.3	Peak Output Power	5180 to 5250	Compliant
15.407(f)	RSS-247 §6.2.2, §6.2.3	Antenna Conducted Spurious Emissions	0.009 to 40000	Compliant
15.407(g)	RSS-247 §6.2.2, §6.2.3	Radiated Spurious Emissions	0.009 to 40000	Compliant
15.407(h)	RSS-247 §6.2.2, §6.2.3	Peak Power Spectral Density	5180 to 5250	Compliant

The testing was performed according to the procedures in ANSI C63.10-2013, KDB 789033 and 47 CFR Part 15. Where applicable, KDB 662911 was followed to sum required measurements.

3.4 Results

In the configuration tested, the EUT complied with the requirements of the specification.

3.5 Test Location

Testing was performed at the Unified Compliance Laboratory 3-Meter and 10-Meter chambers located at 427 West 12800 South, Draper, UT 84020. Unified Compliance Laboratory is accredited by National Voluntary Laboratory Accreditation Program (NVLAP); NVLAP Code 600241-0 which is effective until

30 June 2021. This site has also been registered with Innovations, Science and Economic Development (ISED) department as was accepted under Appendix B, Phase 1 procedures of the APEC Tel MRA for Canadian recognition. ISED No.: 25346, effective until June 30, 2021. Unified Compliance Laboratory has been assigned Conformity Assessment Number US0223 by ISED.

4 Test Equipment

4.1 Conducted Emissions at Mains Ports

Type of Equipment	Manufacturer	Model Number	Asset Number	Date of Last Calibration	Due Date of Calibration
EMI Receiver	AFJ	FFT3010	UCL-2500	9/18/2020	9/17/2021
LISN	AFJ	LS16C/10	UCL-2512	5/26/2020	5/26/2021
Cat6 ISN	Teseq	ISN T8-Cat6	UCL-2971	5/18/2020	5/18/2022
ISN	Teseq	ISN T800	UCL-2974	6/1/2020	6/1/2021
LISN	Com-Power	LIN-120C	UCL-2612	5/19/2021	5/19/2022
AC Power Source	Laplace Instruments	AC1000A	UCL-2857	N/A	N/A
Test Software	UCL	Revision 1	UCL-3107	N/A	N/A

Table 1: List of equipment used for Conducted Emissions Testing at Mains Port

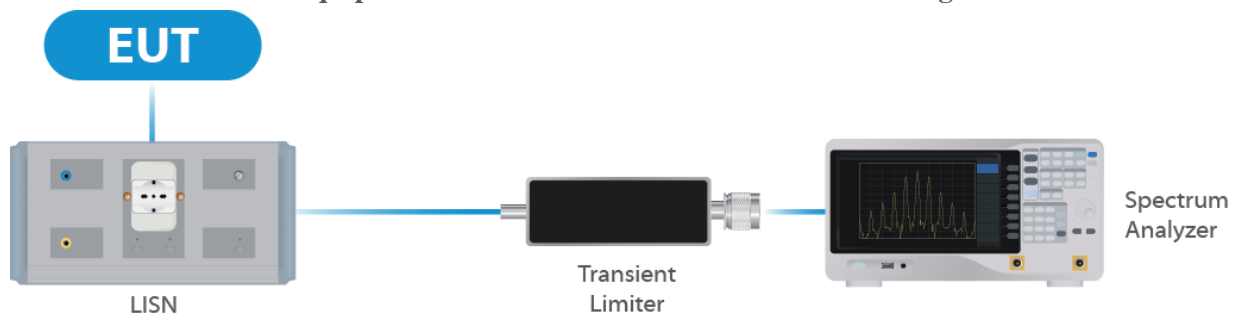

Figure 1: Conducted Emissions Test

4.2 Direct Connect at the Antenna Port Tests

Type of Equipment	Manufacturer	Model Number	Asset Number	Date of Last Calibration	Due Date of Calibration
Spectrum Analyzer	R&S	FSV40	UCL-2861	8/24/2020	8/24/2021
Signal Generator	R&S	SMB100A	UCL-2864	N/A	N/A
Vector Signal Generator	R&S	SMBV100A	UCL-2873	N/A	N/A
Switch Extension	R&S	OSP-B157WX	UCL-2867	9/8/2020	9/8/2021
Switch Extension	R&S	OSP-150W	UCL-2870	3/3/2021	3/3/2022

Table 2: List of equipment used for Direct Connect at the Antenna Port

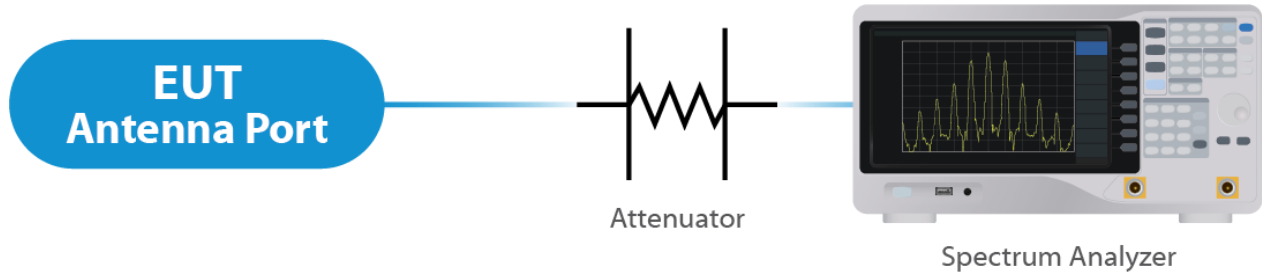

Figure 2: Direct Connect at the Antenna Port Test

4.3 Radiated Emissions

Type of Equipment	Manufacturer	Model Number	Asset Number	Date of Last Calibration	Due Date of Calibration
EMI Receiver	Keysight	N9038A	UCL-2778	6/1/2020	8/1/2021
Pre-Amplifier 9 kHz – 1 GHz	Sonoma Instruments	310N	UCL-2889	9/10/2020	9/10/2021
Double Ridge Horn Antenna	Scwarzbeck	BBHA 9120D	UCL-3065	7/8/2020	7/8/2021
Log Periodic	Scwarzbeck	STLP 9129	UCL-3068	11/16/2020	11/16/2021
15 - 40 GHz Horn Antenna	Scwarzbeck	BBHA 9170	UCL-2487	5/21/2020	5/21/2022
1 – 18 GHz Amplifier	Com-Power	PAM 118A	UCL-3833	9/29/2020	9/29/2021
Test Software	UCL	Revision 1	UCL-3108	N/A	N/A

Table 3: List of equipment used for Radiated Emissions

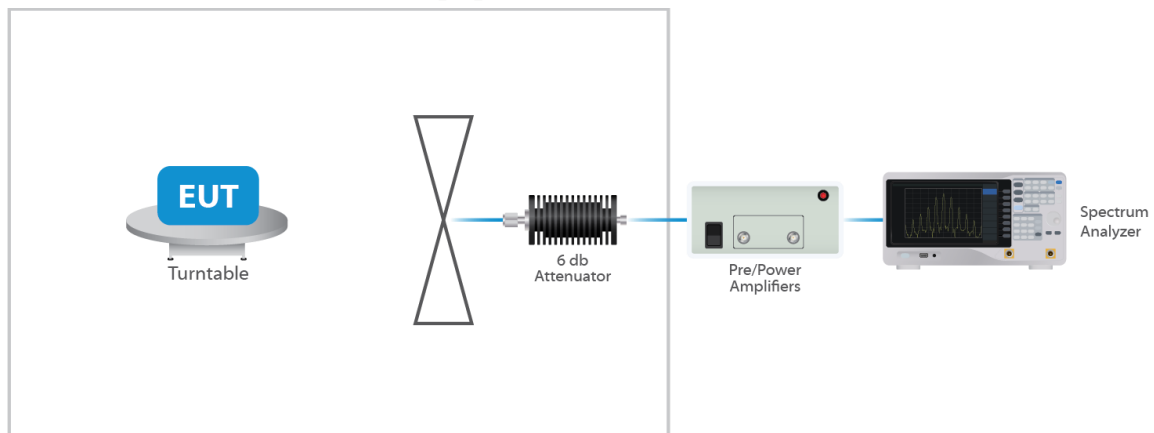

Figure 3: Radiated Emissions Test

4.4 Equipment Calibration

All applicable equipment is calibrated using either an independent calibration laboratory or Unified Compliance Laboratory personnel at intervals defined in ANSI C63.4:2014 following outlined calibration procedures. All measurement instrumentation is traceable to the National Institute of Standards and Technology (NIST). Supporting documentation relative to traceability is on file and is available for examination upon request.

4.5 Measurement Uncertainty

Test	Uncertainty (\pm dB)	Confidence (%)
Conducted Emissions	1.44	95
Radiated Emissions (9 kHz to 30 MHz)	2.50	95
Radiated Emissions (30 MHz to 1 GHz)	4.38	95
Radiated Emissions (1 GHz to 18 GHz)	4.37	95
Radiated Emissions (18 GHz to 40 GHz)	3.93	95
Direct Connect Tests	K Factor	Value
Emissions Bandwidth	2	2.0%
Output Power	2	1.0 dB
Peak Power Spectral Density	2	1.3 dB
Band Edge	2	0.8 dB
Transmitter Spurious Emissions	2	1.8 dB

5 Test Results

5.1 §15.203 Antenna Requirements

The EUT uses an integral. The Maximum gain of the antenna is 5.3 dBi. The antenna is not user replaceable.

Results

The EUT complied with the specification

5.2 Conducted Emissions at Mains Ports Data

5.2.1 Line

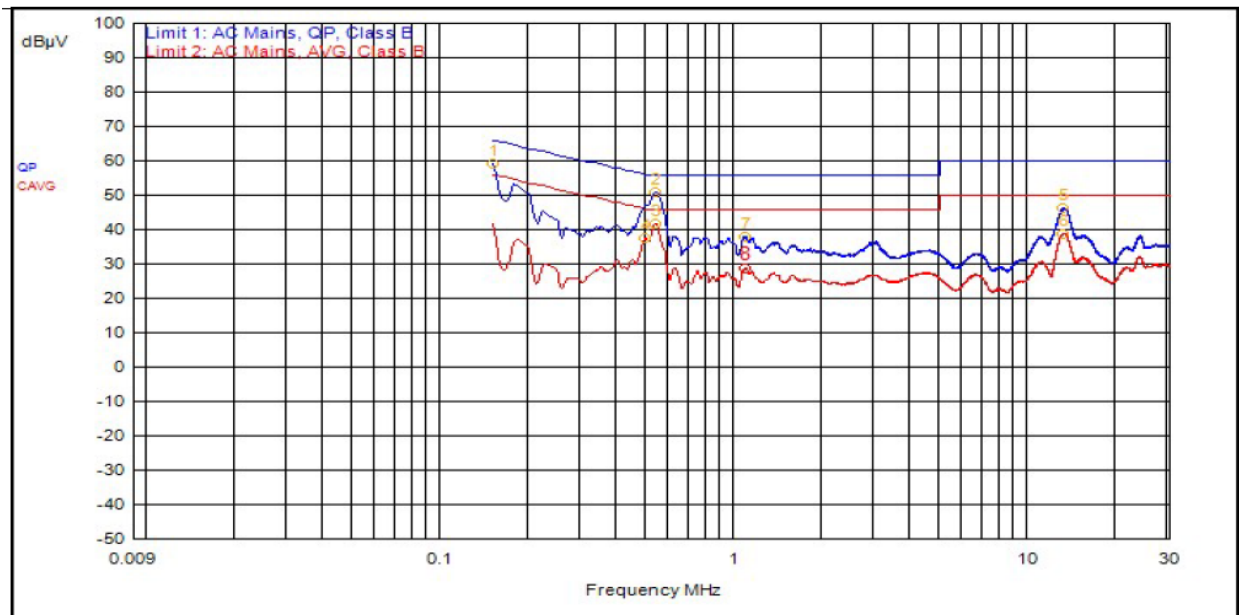

ID	Frequency	Probe	Cable	Atten.	Detector	Meter Read	Meas Level	Limit 1	Limit 1 Dist.	Limit 2	Limit 2 Dist.
2	534,000kHz	12.4			QPeak	38.3	50.7	56.0	-5.3		
1	150,000kHz	12.4			QPeak	46.8	59.2	66.0	-6.8		
5	13.041MHz	12.4			QPeak	33.7	46.2	60.0	-13.8		
7	1.083MHz	12.4			QPeak	25.4	37.8	56.0	-18.2		
3	537,000kHz	12.4			C_AVG	29.2	41.6			46.0	-4.4
4	495,000kHz	12.4			C_AVG	25.1	37.5			46.1	-8.6
6	13.041MHz	12.4			C_AVG	26.4	38.8			50.0	-11.2
8	1.083MHz	12.4			C_AVG	16.3	28.7			46.0	-17.3

5.2.2 Neutral

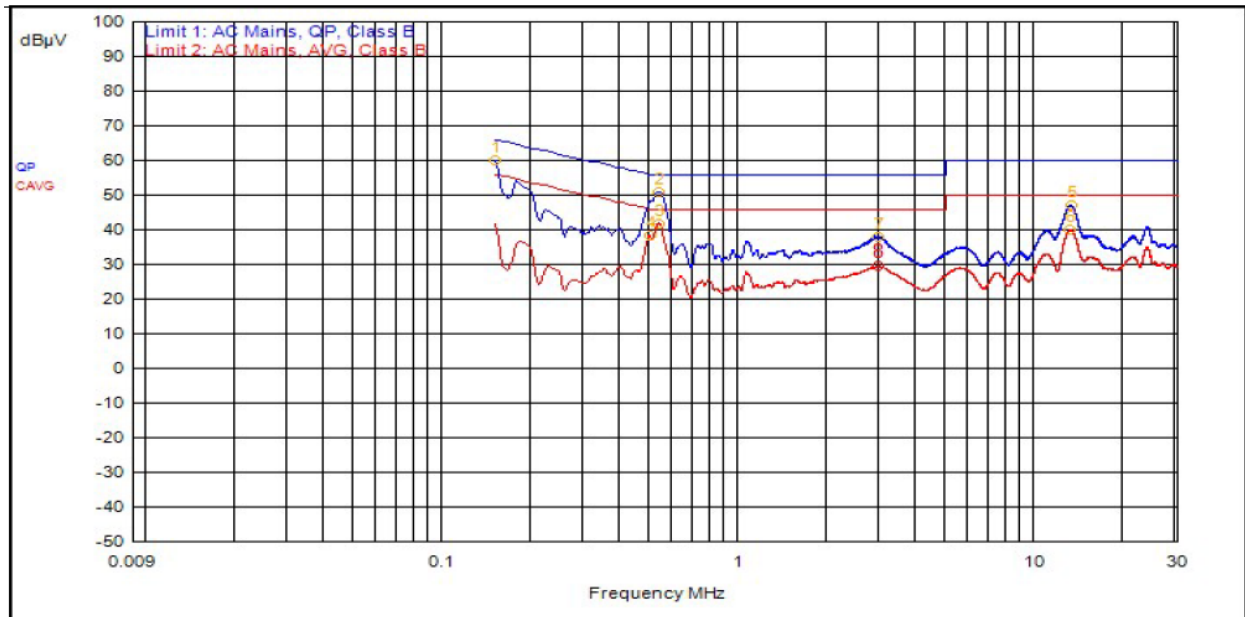

ID	Frequency	Probe	Cable	Atten.	Detector	Meter Read	Meas Level	Limit 1	Limit 1 Dist.	Limit 2	Limit 2 Dist.
2	531,000kHz	12.4			QPeak	38.4	50.8	56.0	-5.2		
1	150,000kHz	12.4			QPeak	47.5	59.9	66.0	-6.1		
5	13.080MHz	12.4			QPeak	34.5	46.9	60.0	-13.1		
7	2.940MHz	12.3			QPeak	25.7	38.0	56.0	-18.0		
3	531,000kHz	12.4			C_AVG	29.4	41.8			46.0	-4.2
4	498,000kHz	12.4			C_AVG	25.9	38.3			46.0	-7.8
6	12.963MHz	12.4			C_AVG	27.5	39.9			50.0	-10.1
8	2.928MHz	12.3			C_AVG	17.2	29.5			46.0	-16.5

Result

The EUT complied with the specification limit.

5.3 §15.403(i) 26 dB Emissions Bandwidth

Nominal BW (MHz)	Frequency (MHz)	99% Bandwidth (MHz)	26 dB Bandwidth (MHz)
20	5180	19.1	21.5
20	5210	21.9	45.3
20	5240	30.1	51.4
40	5190	38.0	40.05
40	5230	38.0	48.75
80	5210	77.0	82.5

Result

The 26 dB bandwidths are reported for information purposes. Please see Annex for all bandwidth measurements.

5.4 §15.403(a)(1) Maximum Average Output Power

The maximum average RF conducted output power measured for this device was 28.85 dBm or 767.36 mW. The limit is 30 dBm, or 1 Watt when using an antenna with 6 dBi or less gain. The antenna has a gain of 5.3 dBi.

Modulation (BW)	Frequency (MHz)	Data Rate	TP Setting	Conducted Output Power *	Measured EIRP	Measured PSD
OFDM 20	5180	Mcs0	36	24.41	29.71	10.73
OFDM 20	5210	Mcs0	44	27.47	32.77	13.94
OFDM 20	5240	Mcs0	50	28.85	34.15	15.01
HT 20	5180	Mcs0	37	24.69	29.99	9.64
HT 20	5210	Mcs0	45	27.90	33.20	13.06
HT 20	5240	Mcs0	47	28.67	33.97	13.75
HT 40	5190	Mcs0	32	22.63	27.93	4.62
HT 40	5230	Mcs0	40	26.25	31.55	8.52
VHT 20	5180	Mcs0	37	24.67	29.97	9.65
VHT 20	5210	Mcs0	45	27.95	33.25	13.20
VHT 20	5240	Mcs0	47	28.77	34.07	13.94
VHT 40	5190	Mcs0	32	22.68	27.98	4.72
VHT 40	5230	Mcs0	40	26.31	31.61	8.58
VHT 80	5210	Mcs0	28	20.60	25.90	-0.74
HE 20	5180	Mcs0	35	24.09	29.39	8.81
HE 20	5210	Mcs0	43	27.40	32.70	12.38
HE 20	5240	Mcs0	46	28.52	33.82	13.41
HE 40	5190	Mcs0	30	21.90	27.20	3.75
HE 40	5230	Mcs0	39	25.88	31.18	8.03
HE 80	5210	Mcs0	27	20.42	25.72	-0.94

Result

In the configuration tested, the maximum average RF outpower was less than 1 watt; therefore, the EUT compiled with the requirements of the specification (see spectrum analyzer plots in attached Annex).

* Gated EIRP shown in the Annex is the conducted measurement

5.5 §15.407(b) Spurious Emissions

5.5.1 Radiated Spurious Emissions in the Restricted Bands of § 15.205

The EUT uses various power settings based on the channel in use. In order to reduce test time, the radiated spurious emissions at the lowest, middle, and highest channel were measured at the maximum power of TP50, as this setting was found to be worst case for spurious emissions. Power was subsequently reduced during in-band and band edge testing. The band edge at the restricted band ending at 5150 MHz was measured using radiated measurement. All emissions modes were tested and the worst-case measurements are shown below. For frequencies above 1 GHz, a measurement of 3 meters was used. For frequencies below 1 GHz, a measurement distance of 10 meters was used.

Result

All emissions in the restricted bands of § 15.205 met the limits specified in § 15.209; therefore, the EUT complies with the specification. All emissions met the limits specified in § 15.407(b). Representative band edge plots are included in this report.

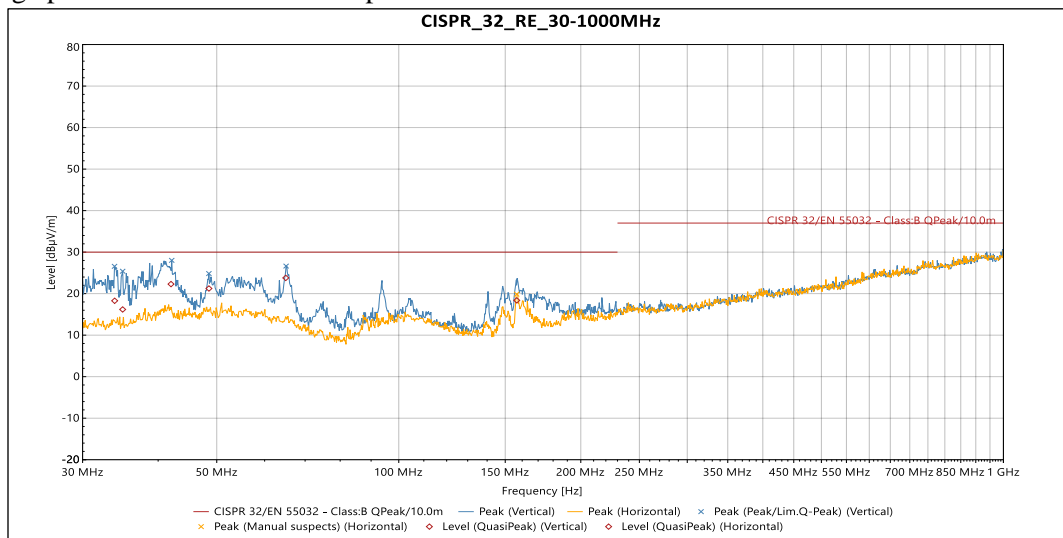

Vertical

Source	Frequency	Level (dBµV/m)	Limit (dBµV/m)	Margin	Azimuth (°)	Height	Pol.	Correction (dB)
QuasiPeak	33.896 MHz	18.279	30	-11.721	81	1.106	Vertical	-15.184
QuasiPeak	34.945 MHz	16.188	30	-13.812	319	1.946	Vertical	-14.833
QuasiPeak	42.009 MHz	22.297	30	-7.703	73	2.164	Vertical	-12.832
QuasiPeak	48.534 MHz	21.24	30	-8.76	20	2.62	Vertical	-12.359
QuasiPeak	65.031 MHz	23.786	30	-6.214	108	2.835	Vertical	-14.684

Horizontal

Source	Frequency	Level (dBµV/m)	Limit (dBµV/m)	Margin	Azimuth (°)	Height	Pol.	Correction (dB)
QuasiPeak	156.72 MHz	18.377	30	-11.623	235	3.995	Horizontal	-17.354

Table 4: Radiated Emissions 30 – 1000 MHz

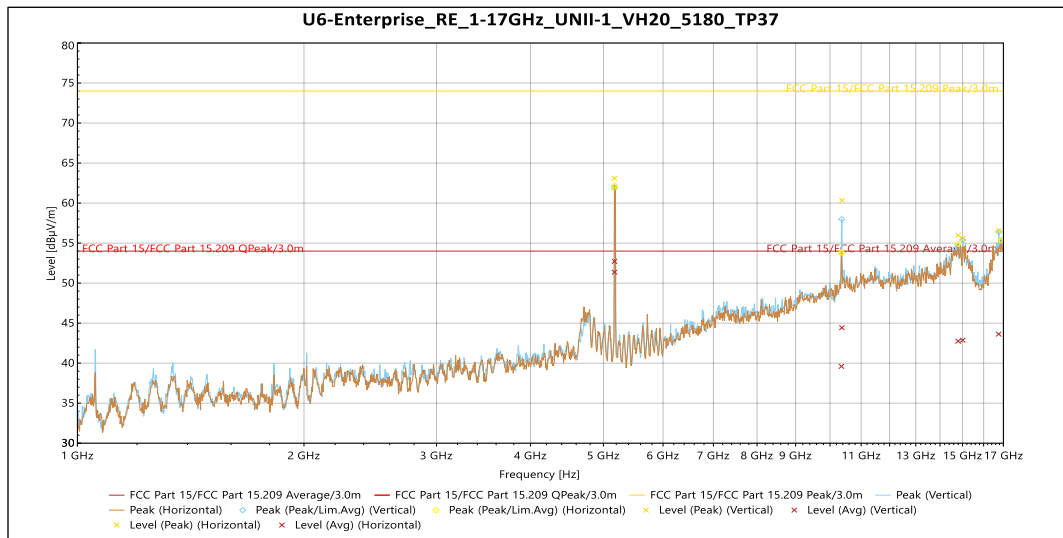

Vertical

Source	Frequency	Level (dBµV/m)	Limit (dBµV/m)	Margin (dB)	Azimuth (°)	Height (m)	Pol.	Correction (dB)
Peak	10.37 GHz	60.338	74	-13.662	11	1.829	Vertical	3.523
Peak	15.008 GHz	55.581	74	-18.419	147	3.162	Vertical	9.717
Peak	16.757 GHz	56.55	74	-17.45	357	3.784	Vertical	11.403

Source	Frequency	Level (dBµV/m)	Limit (dBµV/m)	Margin (dB)	Azimuth (°)	Height (m)	Pol.	Correction (dB)
Avg	10.37 GHz	44.433	54	-9.567	11	1.829	Vertical	3.523
Avg	15.008 GHz	42.867	54	-11.133	147	3.162	Vertical	9.717
Avg	16.757 GHz	43.634	54	-10.366	357	3.784	Vertical	11.403

Horizontal

Source	Frequency	Level (dBµV/m)	Limit (dBµV/m)	Margin (dB)	Azimuth (°)	Height (m)	Pol.	Correction (dB)
Peak	10.356 GHz	53.827	74	-20.173	104	3.307	Horizontal	3.473
Peak	14.8 GHz	55.977	74	-18.023	13	1.833	Horizontal	9.461

Source	Frequency	Level (dBµV/m)	Limit (dBµV/m)	Margin (dB)	Azimuth (°)	Height (m)	Pol.	Correction (dB)
Avg	10.356 GHz	39.598	54	-14.402	104	3.307	Horizontal	3.473
Avg	14.8 GHz	42.74	54	-11.26	13	1.833	Horizontal	9.461

Table 5: Transmitting on the Lowest Frequency 5180 MHz 1 – 17 GHz

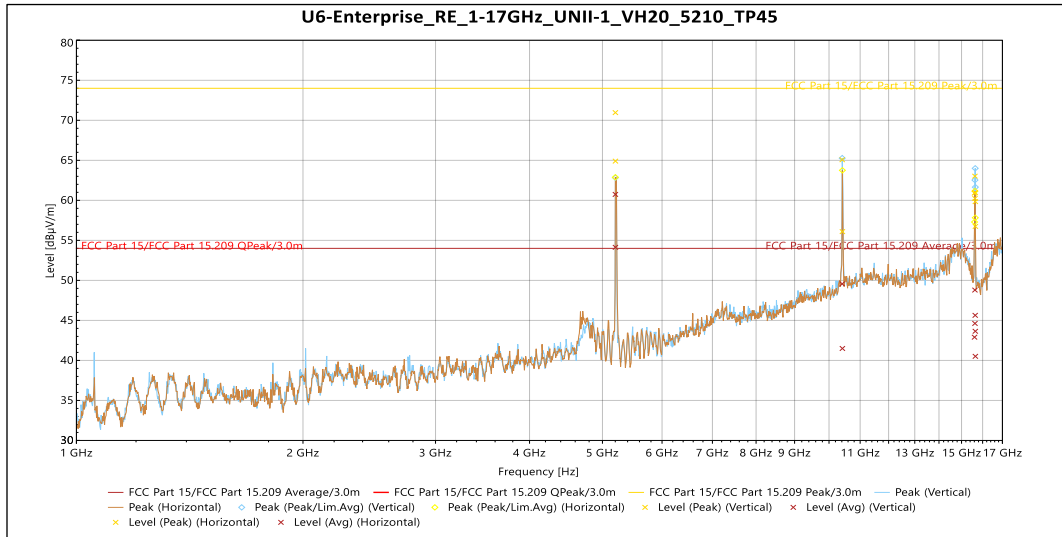

Vertical

Source	Frequency	Level (dBµV/m)	Limit (dBµV/m)	Margin (dB)	Azimuth (°)	Height (m)	Pol.	Correction (dB)
Peak	10.412 GHz	65.065	74	-8.935	329	3.302	Vertical	4.723
Peak	15.63 GHz	60.231	74	-13.769	2	1.812	Vertical	5.736
Peak	15.641 GHz	60.978	74	-13.022	45	2.663	Vertical	5.922
Peak	15.649 GHz	56.74	74	-17.26	16	2.659	Vertical	5.755

Source	Frequency	Level (dBµV/m)	Limit (dBµV/m)	Margin (dB)	Azimuth (°)	Height (m)	Pol.	Correction (dB)
Avg	10.412 GHz	49.564	54	-4.436	329	3.302	Vertical	4.723
Avg	15.63 GHz	44.622	54	-9.378	2	1.812	Vertical	5.736
Avg	15.641 GHz	45.634	54	-8.366	45	2.663	Vertical	5.922
Avg	15.649 GHz	40.515	54	-13.485	16	2.659	Vertical	5.755

Horizontal

Source	Frequency	Level (dBµV/m)	Limit (dBµV/m)	Margin (dB)	Azimuth (°)	Height (m)	Pol.	Correction (dB)
Peak	10.418 GHz	56.094	74	-17.906	26	2.151	Horizontal	4.756
Peak	15.609 GHz	60.903	74	-13.097	25	2.146	Horizontal	5.67
Peak	15.628 GHz	63.015	74	-10.985	25	2.146	Horizontal	5.66
Peak	15.647 GHz	59.844	74	-14.156	25	2.146	Horizontal	5.796

Source	Frequency	Level (dBµV/m)	Limit (dBµV/m)	Margin (dB)	Azimuth (°)	Height (m)	Pol.	Correction (dB)
Avg	10.418 GHz	41.493	54	-12.507	26	2.151	Horizontal	4.756
Avg	15.609 GHz	42.898	54	-11.102	25	2.146	Horizontal	5.67
Avg	15.628 GHz	48.795	54	-5.205	25	2.146	Horizontal	5.66
Avg	15.647 GHz	43.635	54	-10.365	25	2.146	Horizontal	5.796

Table 6: Transmitting on the Middle Frequency 5210 MHz 1 – 17 GHz

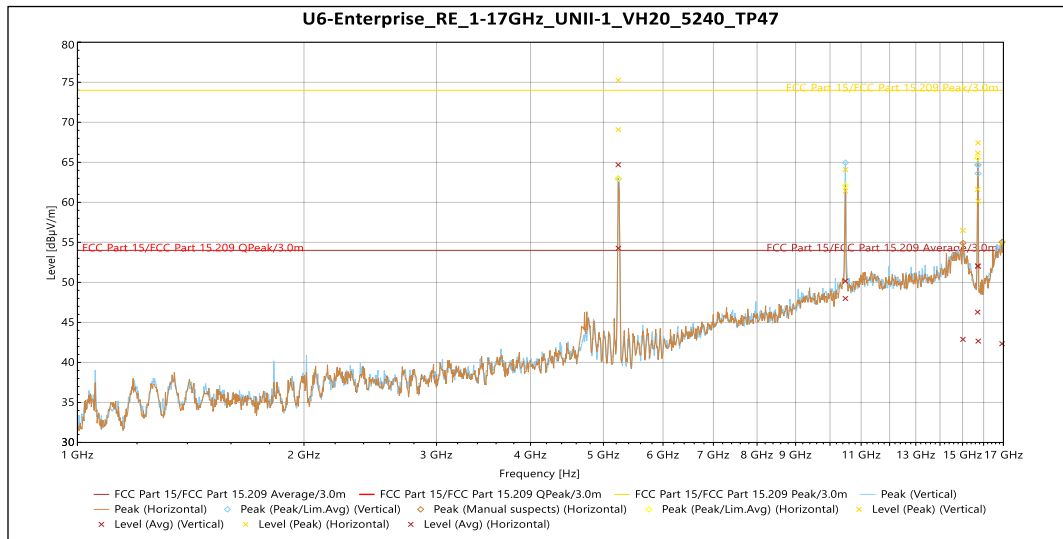

Vertical

Source	Frequency	Level (dBµV/m)	Limit (dBµV/m)	Margin (dB)	Azimuth (°)	Height (m)	Pol.	Correction (dB)
Peak	10.485 GHz	64.102	74	-9.898	349	1.5	Vertical	4.186
Peak	15.71 GHz	61.619	74	-12.381	17	4	Vertical	5.471
Peak	15.73 GHz	67.426	74	-6.574	4	2.312	Vertical	5.604
Peak	15.738 GHz	60.153	74	-13.847	6	2.663	Vertical	5.601

Source	Frequency	Level (dBµV/m)	Limit (dBµV/m)	Margin (dB)	Azimuth (°)	Height (m)	Pol.	Correction (dB)
Avg	10.485 GHz	50.156	54	-3.844	349	1.5	Vertical	4.186
Avg	15.71 GHz	46.278	54	-7.722	17	4	Vertical	5.471
Avg	15.73 GHz	52.024	54	-1.976	4	2.312	Vertical	5.604
Avg	15.738 GHz	42.656	54	-11.344	6	2.663	Vertical	5.601

Horizontal

Source	Frequency	Level (dBµV/m)	Limit (dBµV/m)	Margin (dB)	Azimuth (°)	Height (m)	Pol.	Correction (dB)
Peak	10.483 GHz	61.428	74	-12.572	16	1.647	Horizontal	4.147
Peak	15.019 GHz	56.481	74	-17.519	190	2.151	Horizontal	10.152
Peak	15.718 GHz	66.163	74	-7.837	16	2.655	Horizontal	5.562
Peak	16.928 GHz	54.886	74	-19.114	163	3.662	Horizontal	10.929

Source	Frequency	Level (dBµV/m)	Limit (dBµV/m)	Margin (dB)	Azimuth (°)	Height (m)	Pol.	Correction (dB)
Avg	10.483 GHz	47.987	54	-6.013	16	1.647	Horizontal	4.147
Avg	15.019 GHz	42.881	54	-11.119	190	2.151	Horizontal	10.152
Avg	15.718 GHz	52.052	54	-1.948	16	2.655	Horizontal	5.562
Avg	16.928 GHz	42.325	54	-11.675	163	3.662	Horizontal	10.929

Table 7: Transmitting on the Highest Frequency 5240 MHz 1 – 17 GHz

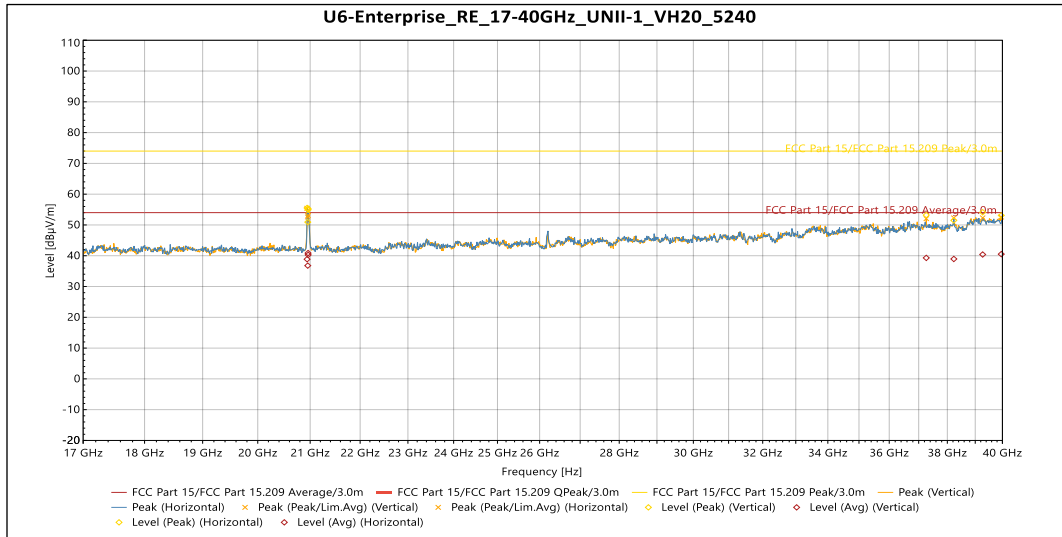

Vertical

Source	Frequency	Level (dBµV/m)	Limit (dBµV/m)	Margin (dB)	Azimuth (°)	Pol.	Correction (dB)
Peak	20.953 GHz	50.93	74	-23.07	41	Vertical	-5.691
Peak	20.961 GHz	54.936	74	-19.064	35	Vertical	-5.621
Peak	37.262 GHz	53.206	74	-20.794	161	Vertical	1.546
Peak	39.957 GHz	53.089	74	-20.911	118	Vertical	3.584

Source	Frequency	Level (dBµV/m)	Limit (dBµV/m)	Margin (dB)	Azimuth (°)	Pol.	Correction (dB)
Avg	20.953 GHz	36.788	54	-17.212	41	Vertical	-5.691
Avg	20.961 GHz	40.267	54	-13.733	35	Vertical	-5.621
Avg	37.262 GHz	39.3	54	-14.7	161	Vertical	1.546
Avg	39.957 GHz	40.521	54	-13.479	118	Vertical	3.584

Horizontal

Source	Frequency	Level (dBµV/m)	Limit (dBµV/m)	Margin (dB)	Azimuth (°)	Pol.	Correction (dB)
Peak	20.94 GHz	55.52	74	-18.48	13	Horizontal	-5.722
Peak	20.959 GHz	55.318	74	-18.682	28	Horizontal	-5.643
Peak	38.231 GHz	51.489	74	-22.511	195	Horizontal	1.268
Peak	39.271 GHz	54.115	74	-19.885	1	Horizontal	2.928

Source	Frequency	Level (dBµV/m)	Limit (dBµV/m)	Margin (dB)	Azimuth (°)	Pol.	Correction (dB)
Avg	20.94 GHz	38.867	54	-15.133	13	Horizontal	-5.722
Avg	20.959 GHz	40.864	54	-13.136	28	Horizontal	-5.643
Avg	38.231 GHz	38.948	54	-15.052	195	Horizontal	1.268
Avg	39.271 GHz	40.404	54	-13.596	1	Horizontal	2.928

Table 8: Transmitting on the Highest Frequency 5240 MHz 17 – 40 GHz (worse case)

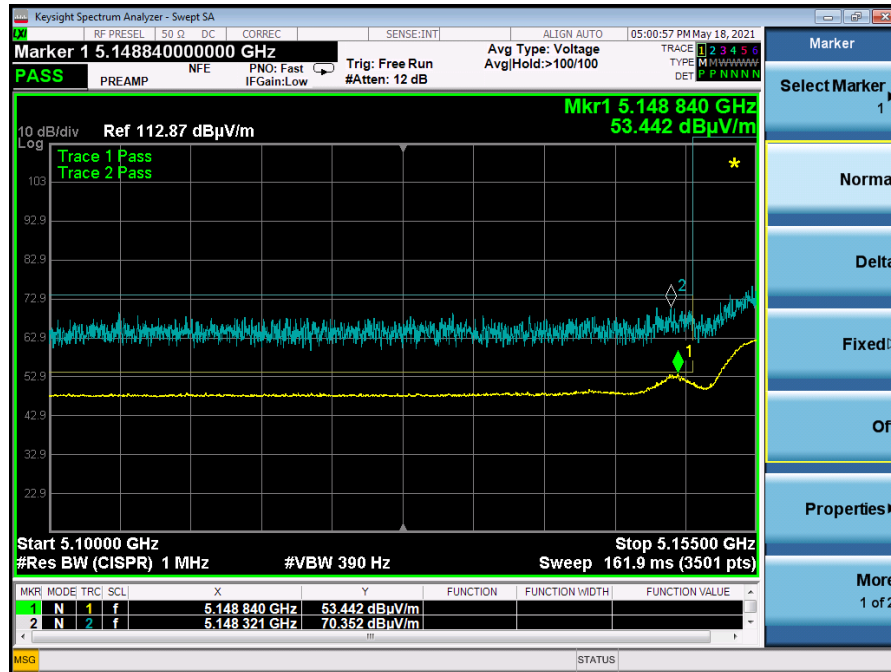

Graph 1: Lower Band Edge Plot – 5180 MHz – a Mode

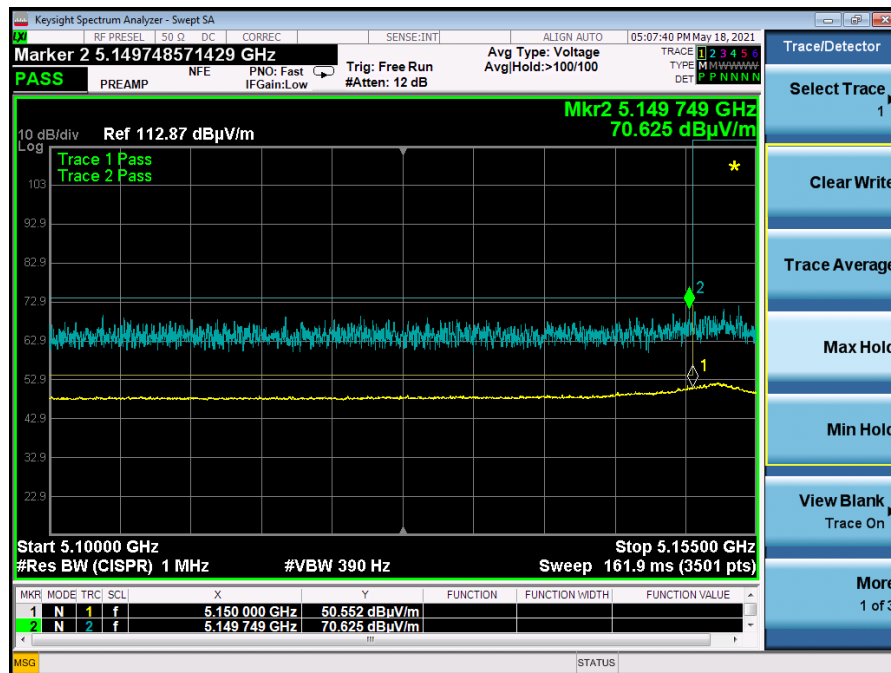

Graph 2: Middle Band Edge Plot – 5210 MHz – a Mode

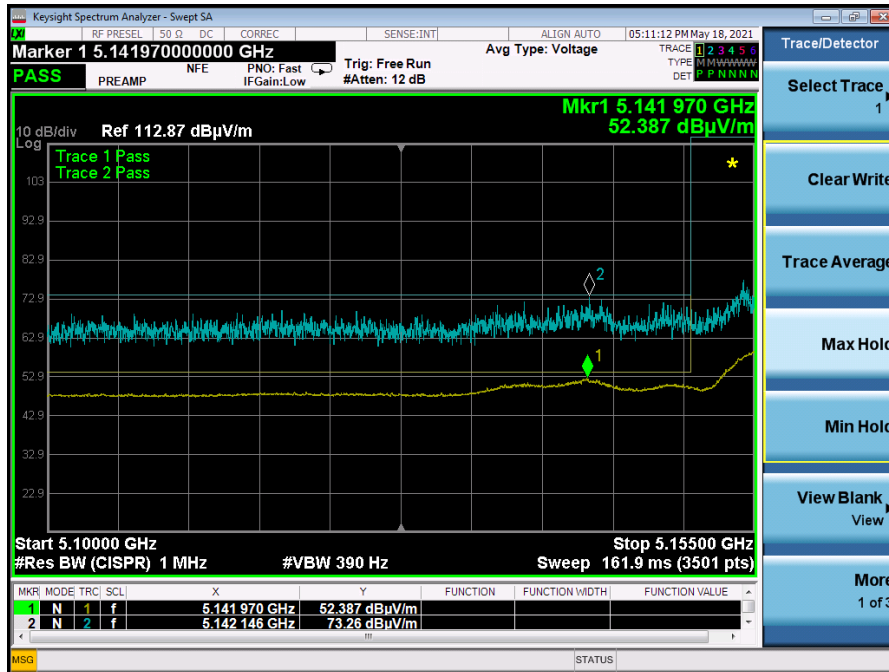

Graph 3: Upper Band Edge Plot – 5240 MHz – a Mode

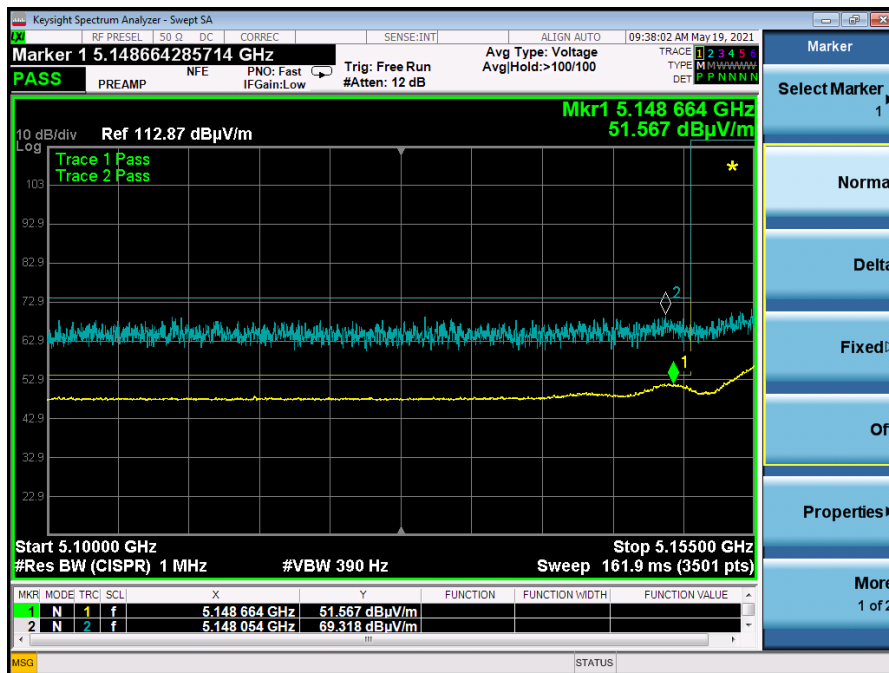

Graph 4: Lower Band Edge Plot – 5180 MHz – n20 Mode

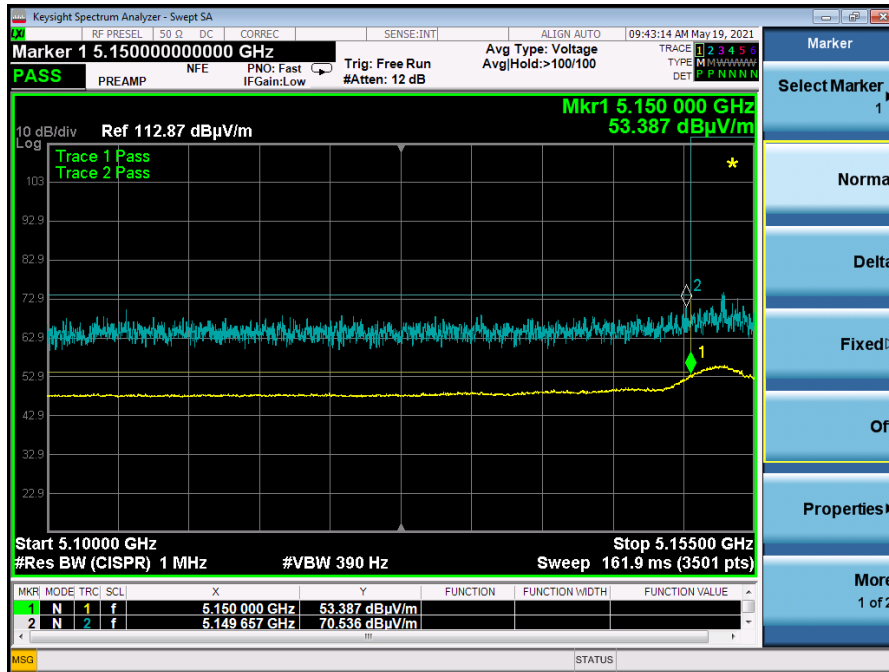

Graph 5: Middle Band Edge Plot – 5210 MHz – n20 Mode

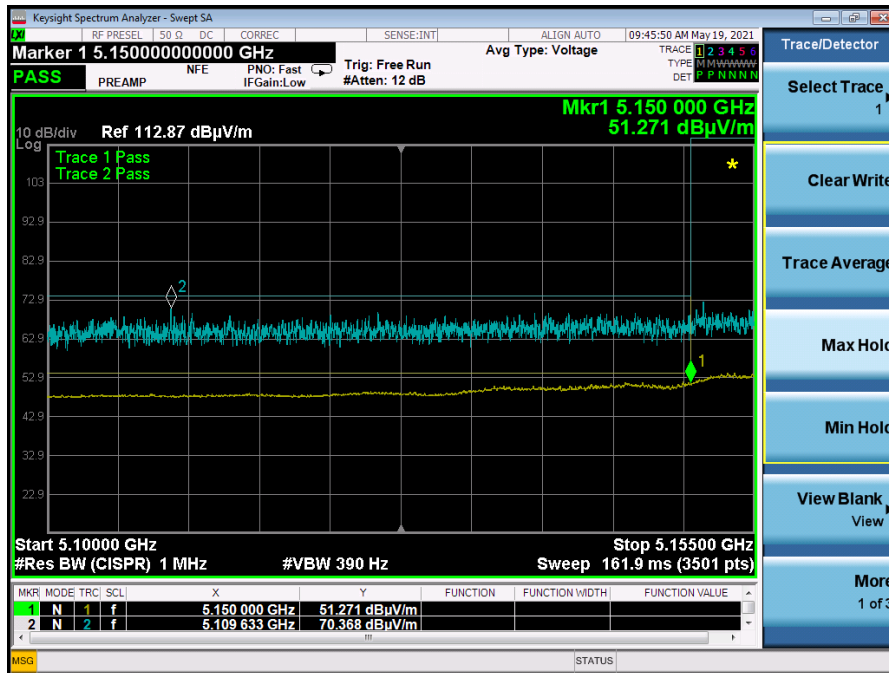

Graph 6: Upper Band Edge Plot – 5240 MHz – n20 Mode

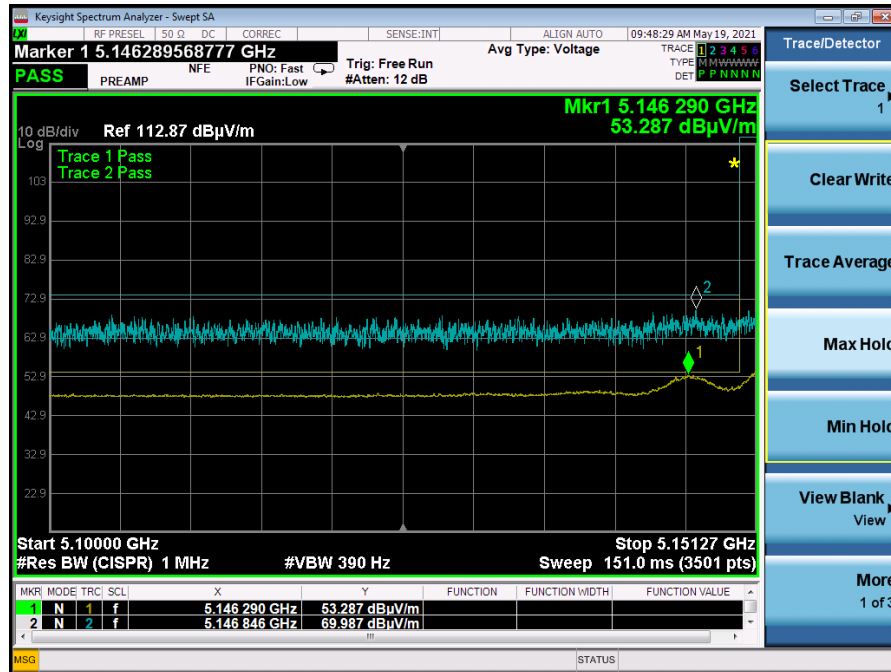

Graph 7: Lower Band Edge Plot – 5190 MHz – n40 Mode

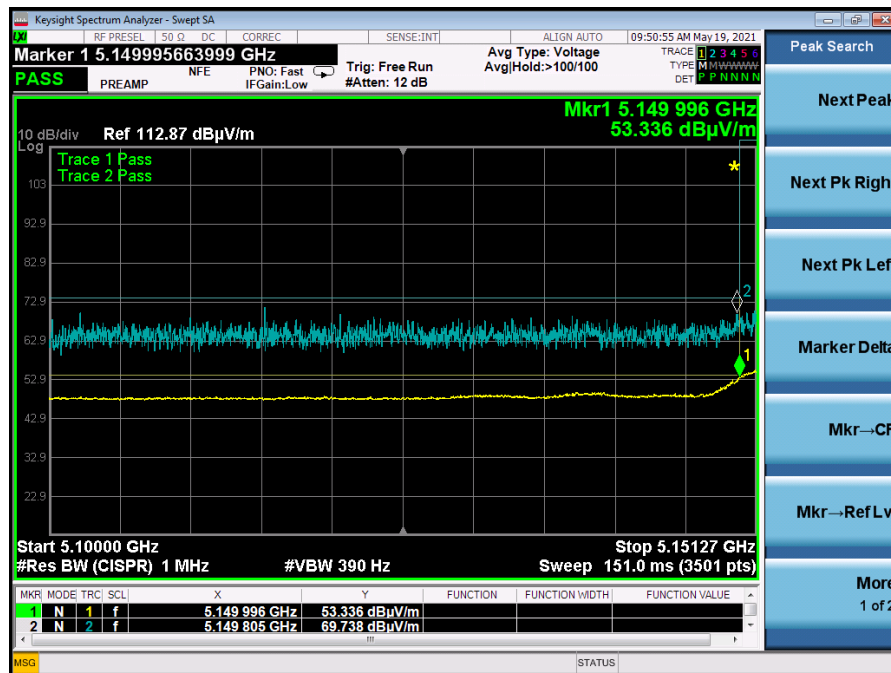

Graph 8: Upper Band Edge Plot – 5230 MHz – n40 Mode

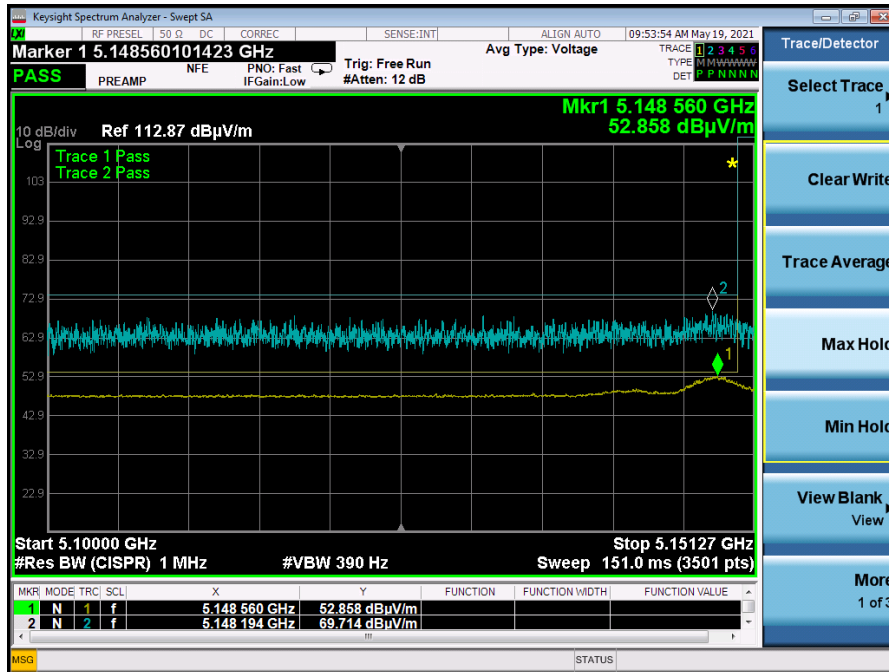

Graph 9: Lower Band Edge Plot – 5180 MHz – ac20 Mode

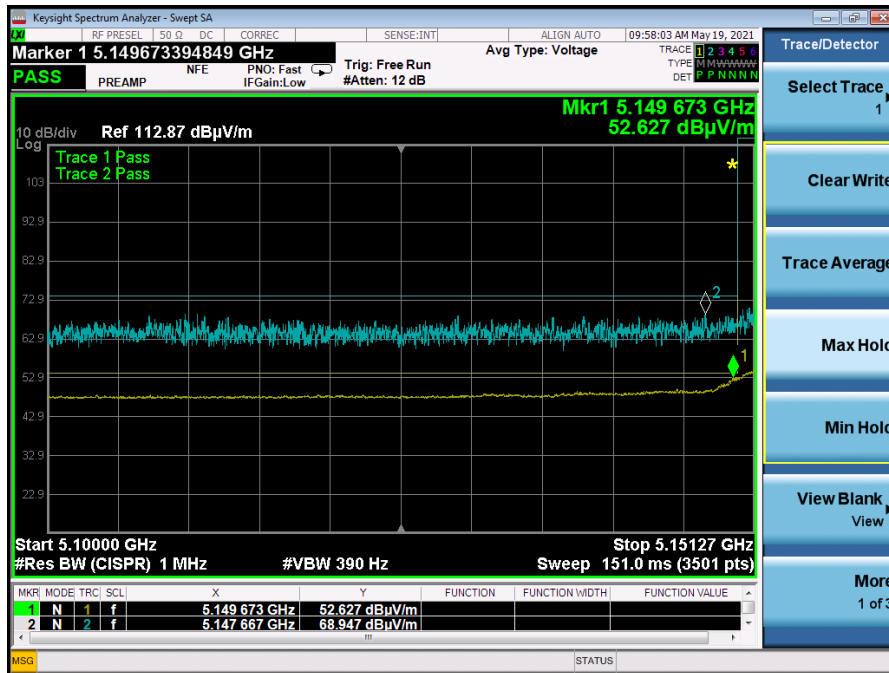

Graph 10: Middle Band Edge Plot – 5210 MHz – ac20 Mode

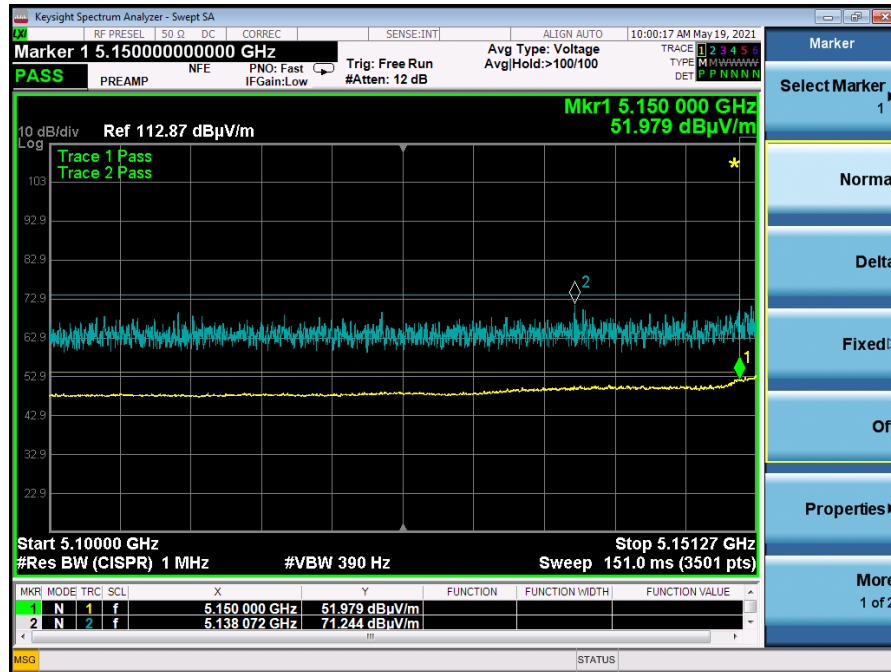

Graph 11: Upper Band Edge Plot – 5240 MHz – acT20 Mode

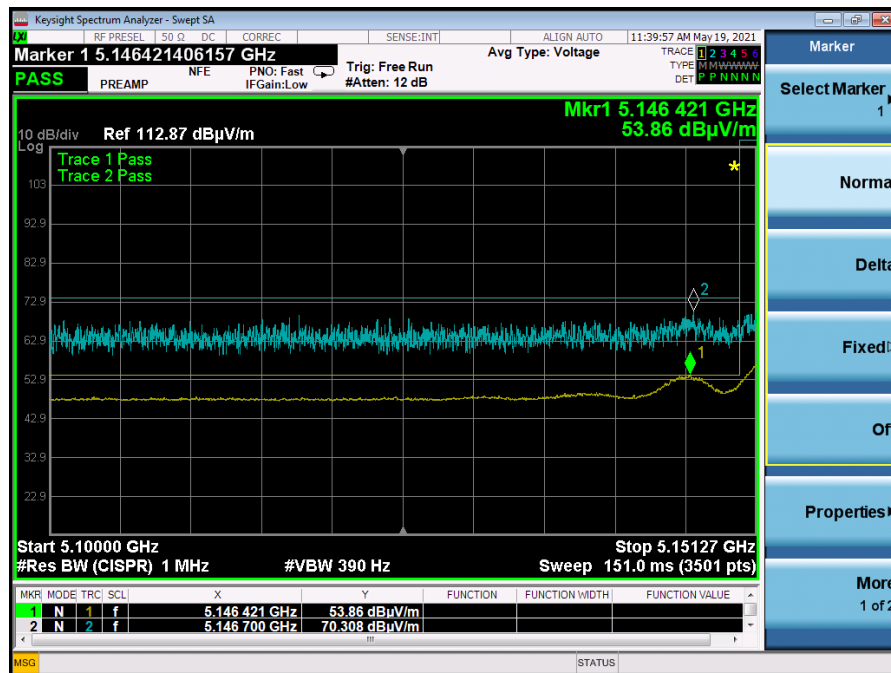

Graph 12: Lower Band Edge Plot – 5190 MHz – ac40 Mode

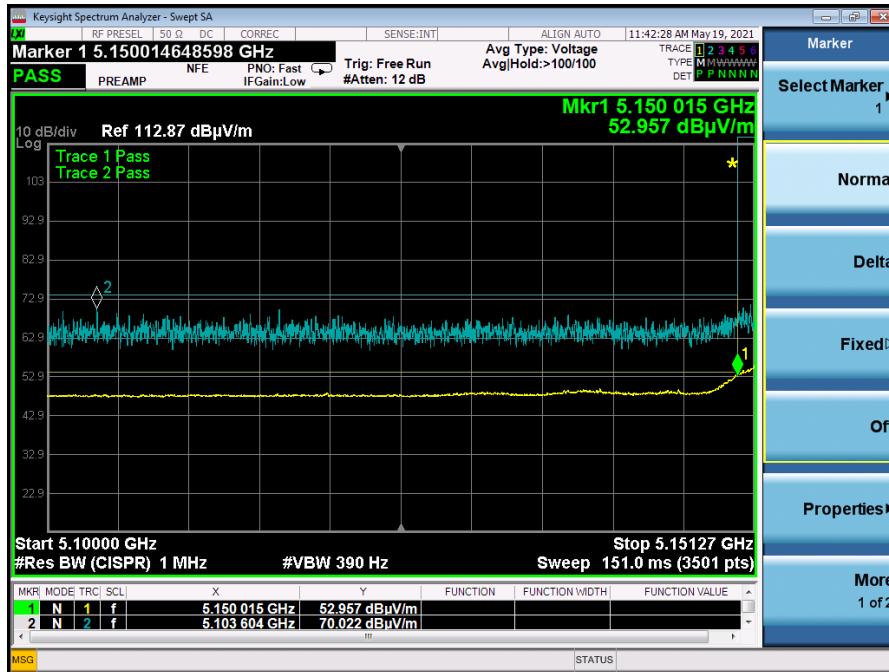

Graph 13: Upper Band Edge Plot – 5230 MHz – ac40 Mode

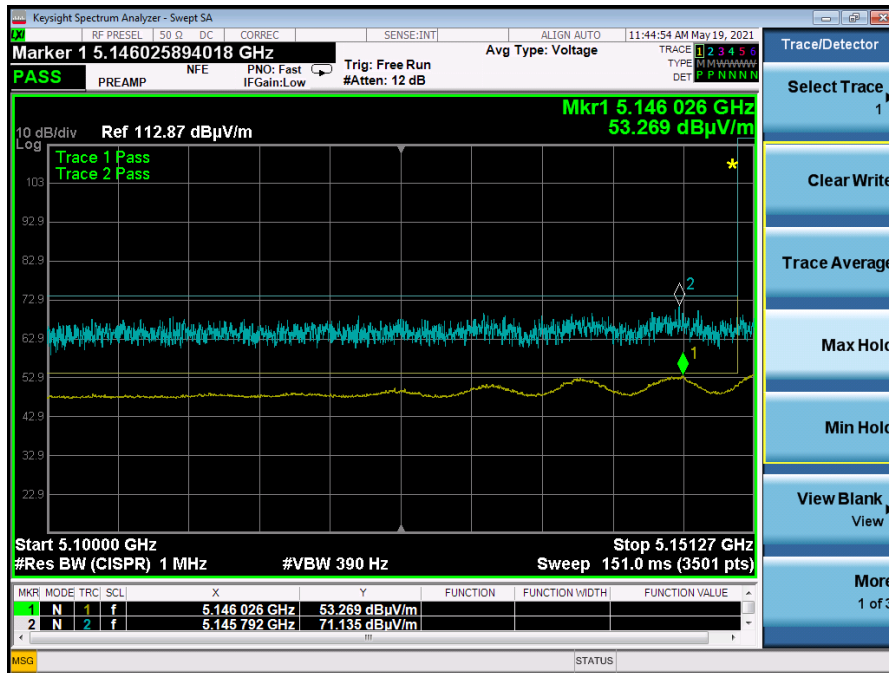

Graph 14: Band Edge Plot – 5240 MHz – ac80 Mode

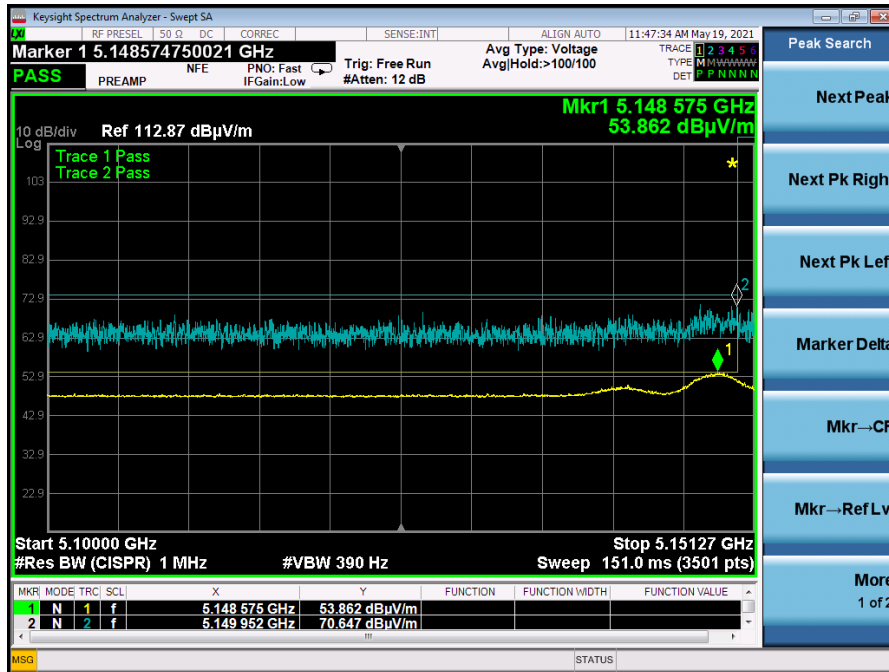

Graph 15: Lower Band Edge Plot – 5180 MHz – ax20 Mode

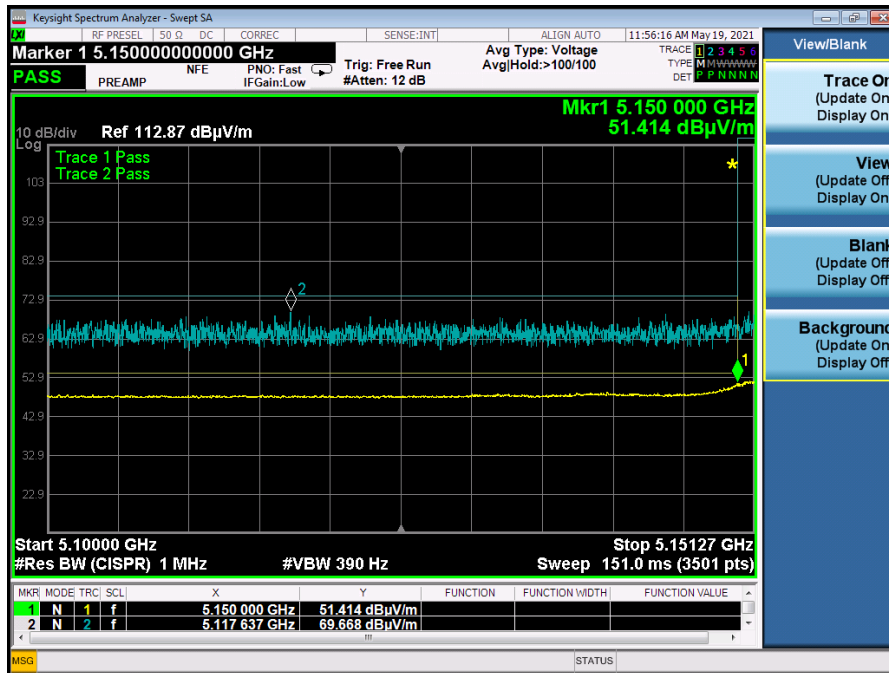

Graph 16: Middle Band Edge Plot – 5210 MHz – ax20 Mode

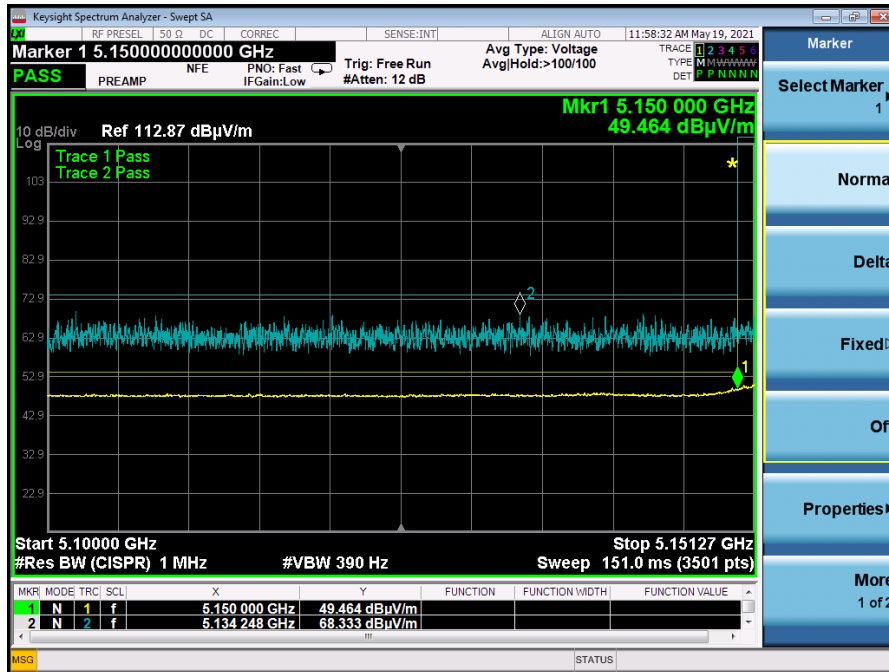

Graph 17: Upper Band Edge Plot – 5240 MHz – ax20 Mode

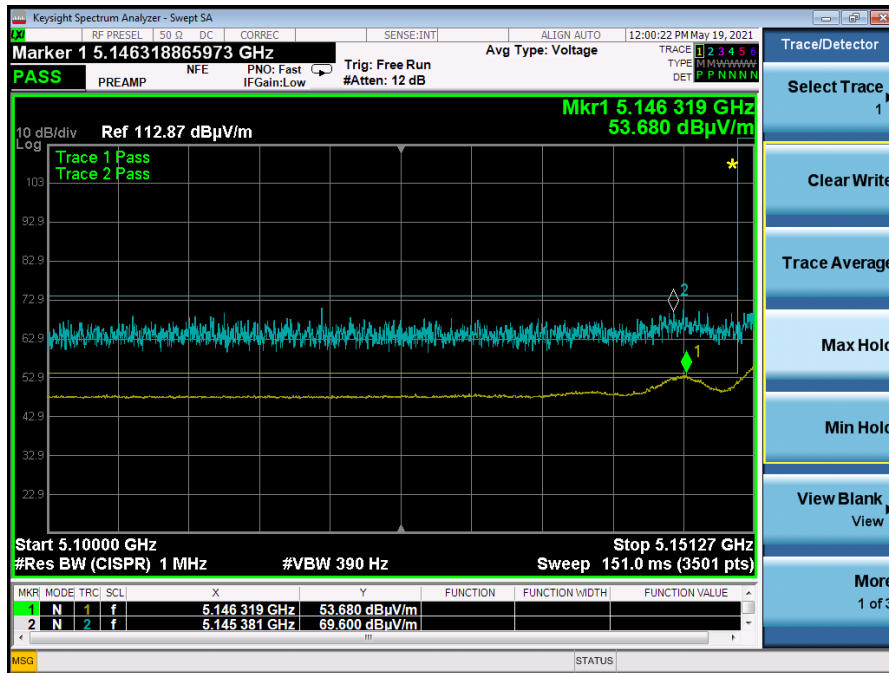

Graph 18: Lower Band Edge Plot – 5190 MHz – ax40 Mode

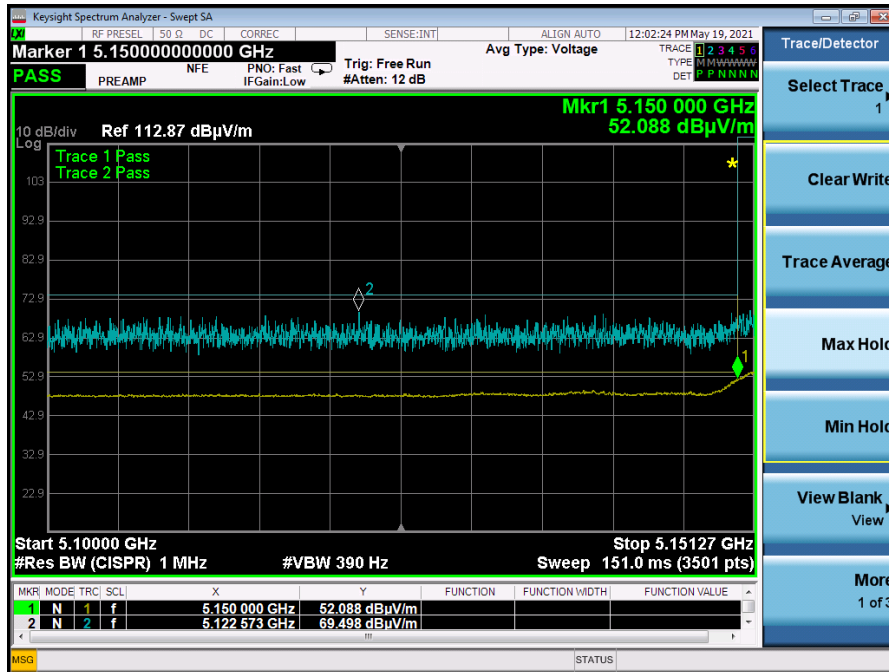

Graph 19: Upper Band Edge Plot – 5230 MHz – ax40 Mode

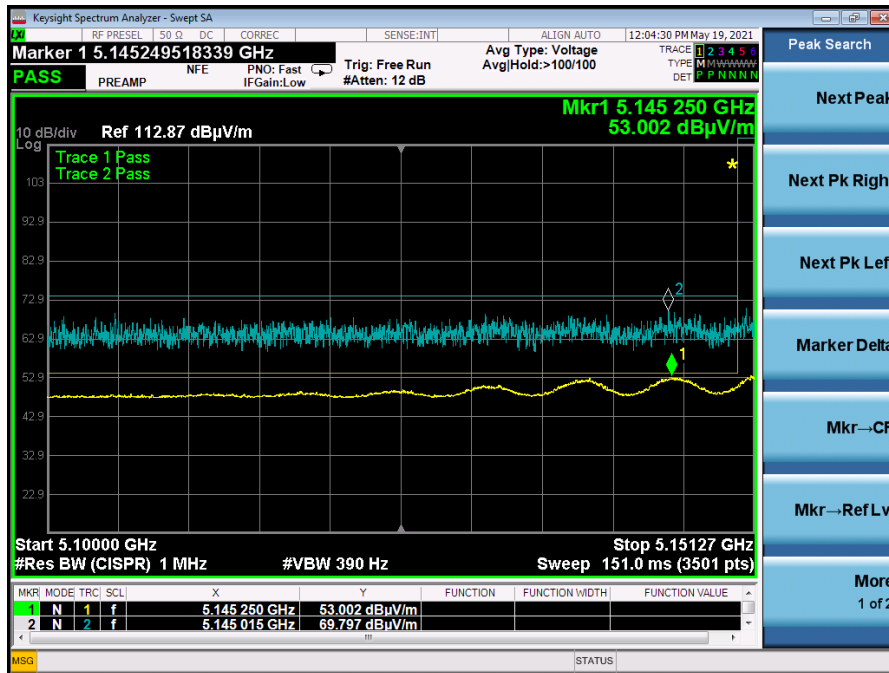

Graph 20: Band Edge Plot – 5240 MHz – ax20 Mode

5.6 §15.407(a) Maximum Power Spectral Density

The maximum average power spectral density conducted from the intentional radiator of the antenna shall not be greater than 17 dBm in any 1 MHz band during any time interval of continuous transmission. Results of this testing are summarized.

Modulation (BW)	Frequency (MHz)	Data Rate	TP Setting	Measured PSD
OFDM 20	5180	Mcs0	36	10.73
OFDM 20	5210	Mcs0	44	13.94
OFDM 20	5240	Mcs0	50	15.01
HT 20	5180	Mcs0	37	9.64
HT 20	5210	Mcs0	45	13.06
HT 20	5240	Mcs0	47	13.75
HT 40	5190	Mcs0	32	4.62
HT 40	5230	Mcs0	40	8.52
VHT 20	5180	Mcs0	37	9.65
VHT 20	5210	Mcs0	45	13.20
VHT 20	5240	Mcs0	47	13.94
VHT 40	5190	Mcs0	32	4.72
VHT 40	5230	Mcs0	40	8.58
VHT 80	5210	Mcs0	28	-0.74
HE 20	5180	Mcs0	35	8.81
HE 20	5210	Mcs0	43	12.38
HE 20	5240	Mcs0	46	13.41
HE 40	5190	Mcs0	30	3.75
HE 40	5230	Mcs0	39	8.03
HE 80	5210	Mcs0	27	-0.94

Result

The maximum average power spectral density was less than the limit of 17dBm; therefore, the EUT complies with the specification.

-- End of Test Report --