



EMC

TEST REPORT

Report No. : 141100201TWN-001
Model No. : SM-MI-250
Issued Date : Apr. 24, 2015

Applicant: Ubiquiti Networks, Inc.
2580 Orchard Parkway, San Jose, CA 95131, CA

Test Method/ Standard: 47 CFR FCC Part 15.247 & ANSI C63.4 2014
KDB 558074 D01 v03r02

Test Site: 93910

Test By: Intertek Testing Services Taiwan Ltd.
No. 11, Lane 275, Ko-Nan 1 Street, Chia-Tung Li,
Shiang-Shan District, Hsinchu City, Taiwan

It may be duplicated completely for legal use with the allowance of the applicant. It shall not be reproduced except in full, without the written approval of Intertek Laboratory. The test result(s) in this report only applies to the tested sample(s).

The test report was prepared by:

Evelyn Lee / Officer

These measurements were taken by:

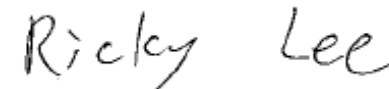
Ricky Lee / Engineer

The test report was reviewed by:

Name Jimmy Yang
Title Senior Engineer

Table of Contents

1. Summary of Test Data.....	4
2. General Information.....	5
2.1 Identification of the EUT.....	5
2.2 Description of EUT.....	6
2.3 Channel Number of EUT.....	6
2.4 Additional information of EUT.....	6
2.5 Antenna description.....	7
2.6 Peripherals equipment.....	7
2.7 Operation mode.....	7
2.8 Applied test modes and channels.....	8
2.9 Test software.....	8
3. Minimum 6 dB Bandwidth.....	9
3.1 Operating environment.....	9
3.2 Limit for minimum 6dB bandwidth.....	9
3.3 Measuring instrument setting.....	9
3.4 Test procedure.....	9
3.5 Test diagram.....	10
3.6 Test results.....	10
4. Maximum Peak Conducted Output Power.....	13
4.1 Operating environment.....	13
4.2 Limit for maximum peak conducted output power.....	13
4.3 Measuring instrument setting.....	13
4.4 Test procedure.....	13
4.5 Test diagram.....	14
4.6 Test result.....	14
5. Power Spectral Density.....	15
5.1 Operating environment.....	15
5.2 Limit for power spectrum density.....	15
5.3 Measuring instrument setting.....	15
5.4 Test procedure.....	16
5.5 Test diagram.....	16
5.6 Test results.....	16

- 6. Emissions In Non-Restricted Frequency Bands 19
 - 6.1 Operating environment 19
 - 6.2 Limit for emissions in non-restricted frequency bands..... 19
 - 6.3 Measuring instruments setting 19
 - 6.4 Test procedure 20
 - 6.5 Test diagram..... 20
 - 6.6 Test results..... 21
- 7. Emissions In Restricted Frequency Bands (Radiated emission measurements)..... 23
 - 7.1 Operating environment 23
 - 7.2 Limit for emission in restricted frequency bands (Radiated emission measurement) 23
 - 7.3 Measuring instrument setting..... 24
 - 7.4 Test procedure 25
 - 7.5 Test configuration 26
 - 7.5.1 Radiated emission 9kHz ~ 30MHz using loop Antenna 26
 - 7.5.2 Radiated emission below 1GHz using Bilog Antenna..... 26
 - 7.5.3 Radiated emission above 1GHz using Horn Antenna..... 27
 - 7.6 Test result 28
 - 7.6.1 Measurement results: frequencies 9kHz ~ 30MHz..... 28
 - 7.6.2 Measurement results: frequencies below 1 GHz 29
 - 7.6.3 Measurement results: frequency from 1GHz to 25GHz 30
- 8. Emission On Band Edge 32
 - 8.1 Operating environment 32
 - 8.2 Measuring instrument setting..... 32
 - 8.3 Test procedure 32
 - 8.4 Test results..... 33
- 9. AC Power Line Conducted Emission 34
 - 9.1 Operating environment 34
 - 9.2 Limit for AC power line conducted emission 34
 - 9.3 Measuring instrument setting..... 34
 - 9.4 Test procedure 35
 - 9.5 Test diagram..... 35
 - 9.6 Test results..... 36
- Appendix A: Test equipment list..... 38
- Appendix B: Measurement Uncertainty 39

1. Summary of Test Data

Test Requirement	Applicable Rule (Section 15.247)	Result
Minimum 6 dB Bandwidth	15.247(a)(2) KDB 558074 D01 v03r02	Pass
Maximum Peak Conducted Output Power	15.247(b)(3)	Pass
Power Spectral Density	15.247(e)	Pass
Emissions In Non-Restricted Frequency Bands	15.247(d)	Pass
Emissions In Restricted Frequency Bands (Radiated emission measurements)	15.247(d), 15.205, 15.209	Pass
Emission On The Band Edge	15.247(d), 15.205	Pass
AC Power Line Conducted Emission	15.207	Pass
Antenna Requirement	15.203	Pass



2. General Information

2.1 Identification of the EUT

Product:	Micro inverter
Model No:	SM-MI-250
FCC ID:	SWX-MICROINV250W
Manufacturer:	Lite-On Network Communication (Dongguan) Limited No. 30 Keji Rd, Yinhu Industrial Park, Qingxi Town, Dongguan City, China
Bluetooth version	BT4.0 low energy mode
Operating Frequency:	2402MHz ~ 2480MHz
Channel Number:	40 Channels
Access scheme:	FHSS
Modulation:	GFSK
Rated Power:	Turn on the device: Input rated voltage: DC 36V, AC 240V/60Hz Operation mode: Input rated voltage: DC 36V, Output rated voltage: AC 240V/60Hz
Power Cord:	N/A
Sample Received:	Nov. 14, 2014
Sample condition:	Workable
Test Date(s):	Jan. 05, 2015 ~ Apr. 23, 2015
Note 1:	This report is for the exclusive use of Intertek's Client and is provided pursuant to the agreement between Intertek and its Client. Intertek's responsibility and liability are limited to the terms and conditions of the agreement. Intertek assumes no liability to any party, other than to the Client in accordance with the agreement, for any loss, expense or damage occasioned by the use of this report. Only the Client is authorized to permit copying or distribution of this report and then only in its entirety. Any use of the Intertek name or one of its marks for the sale or advertisement of the tested material, product or service must first be approved in writing by Intertek. The observations and test results in this report are relevant only to the sample tested. This report by itself does not imply that the material, product, or service is or has ever been under an Intertek certification program.
Note 2:	When determining the test conclusion, the Measurement Uncertainty of test has been considered.

2.2 Description of EUT

Modulation mode	Transmit path
	Chain 0/Main
BT 4.0	V

2.3 Channel Number of EUT

Channel No.	Frequency	Channel No.	Frequency	Channel No.	Frequency	Channel No.	Frequency
0	2402	10	2422	20	2442	30	2462
1	2404	11	2424	21	2444	31	2464
2	2406	12	2426	22	2446	32	2466
3	2408	13	2428	23	2448	33	2468
4	2410	14	2430	24	2450	34	2470
5	2412	15	2432	25	2452	35	2472
6	2414	16	2434	26	2454	36	2474
7	2416	17	2436	27	2456	37	2476
8	2418	18	2438	28	2458	38	2478
9	2420	19	2440	29	2460	39	2480

2.4 Additional information of EUT

Hardware version: MI250_001A

Software version: MI250_001A

Serial number: N/A

2.5 Antenna description

The EUT uses a detachable antenna.

Antenna Gain : 6.5 dBi
Antenna Type : Dipole antenna
Connector Type : SMA RP plug

2.6 Peripherals equipment

Peripherals	Brand	Model No.	Serial No.	Data cable
Notebook PC	DELL	Latitude D610	1YWZK1S	USB shielded cable meter × 1
DC battery	CS3	GPL 121000	N/A	N/A

2.7 Operation mode

The EUT was supplied by DC 36V and can convert it to AC 240V/60Hz.

The Duty cycle of TX-MODE is 98%

2.8 Applied test modes and channels

Test items	Mode	Channel	Antenna
Minimum 6 dB Bandwidth	BT 4.0	Low, Middle, High	Chain0
Maximum peak conducted output power	BT 4.0	Low, Middle, High	Chain0
Power Spectral Density	BT 4.0	Low, Middle, High	Chain0
RF Antenna Conducted Spurious	BT 4.0	Low, Middle, High	Chain0
Radiated spurious Emission 30MHz~1GHz	BT 4.0	Middle	Chain0
Radiated Spurious Emission 1GHz~10th Harmonic	BT 4.0	Low, Middle, High	Chain0
Emission on the Band Edge	BT 4.0	Low, High	Chain0
AC Power Line Conducted Emission	BT 4.0	Normal mode	Chain0

2.9 Test software

TX-MODE based on “mbt Tool” to execute, and select different frequency and modulation.

3. Minimum 6 dB Bandwidth

3.1 Operating environment

Temperature:	25	°C
Relative Humidity:	50	%
Atmospheric Pressure	1008	hPa
Requirement & Test method	15.247(a)(2) KDB 558074 D01 v03r02	
Channel number	Low, Middle, High	

3.2 Limit for minimum 6dB bandwidth

The minimum 6 dB bandwidth shall be at least 500 kHz.

3.3 Measuring instrument setting

Spectrum analyzer settings	
Spectrum Analyzer function	Setting
Detector	Peak
RBW	100kHz
VBW	$\geq 3 \times \text{RBW}$
Sweep	Auto couple
Trace	Allow the trace to stabilize.
Span	Between two times and five times the occupied bandwidth
Attenuation	Auto

3.4 Test procedure

1. The transmitter output was connected to the spectrum analyzer.
2. Test was performed in accordance with clause 8.1 option1 of KDB 558074 D01
3. Measure the maximum width of the emission that is constrained by the frequencies associated with the two outermost amplitude points (upper and lower frequencies) that are attenuated by 6 dB relative to the maximum level measured in the fundamental emission

3.5 Test diagram

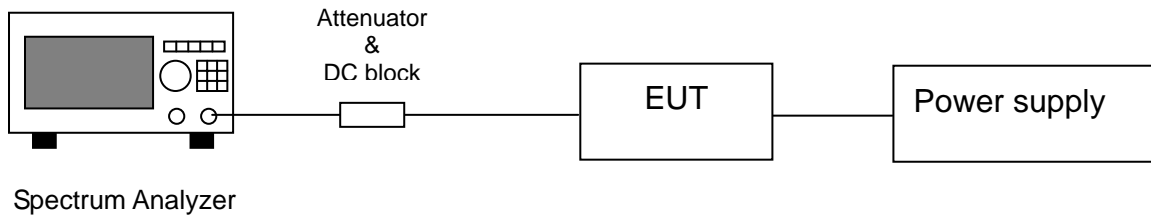

3.6 Test results

Mode	Channel	Frequency (MHz)	6dB Bandwidth (MHz)	Limit (MHz)	Pass/Fail
BT 4.0	Low	2402	0.707	0.5	Pass
	Middle	2442	0.705	0.5	Pass
	High	2480	0.696	0.5	Pass

6dB Occupied Bandwidth @ GFSK mode Ch Low

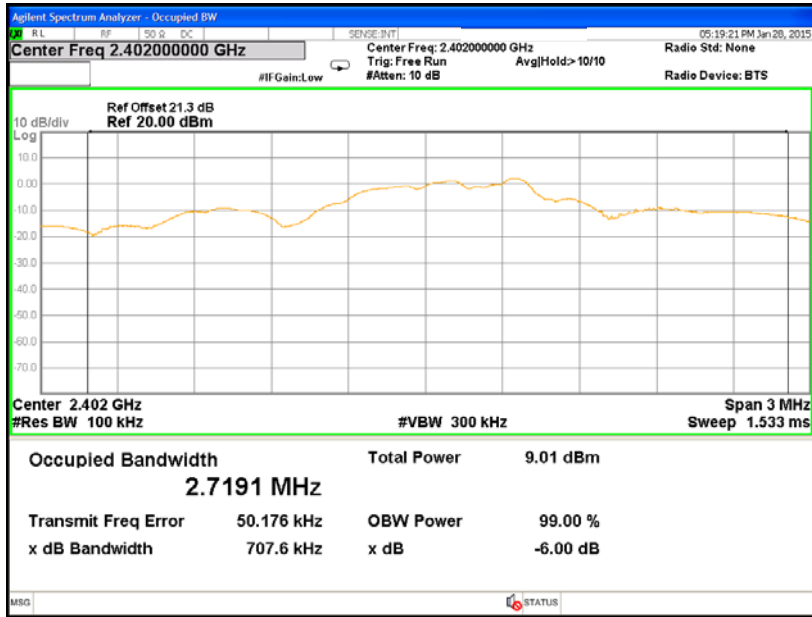

6dB Occupied Bandwidth @ GFSK mode Ch Middle

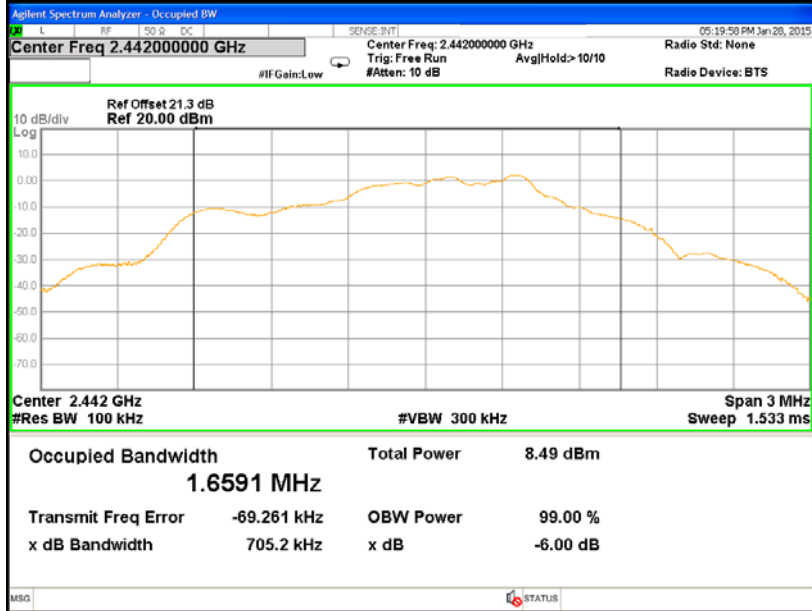

6dB Occupied Bandwidth @ GFSK mode Ch High

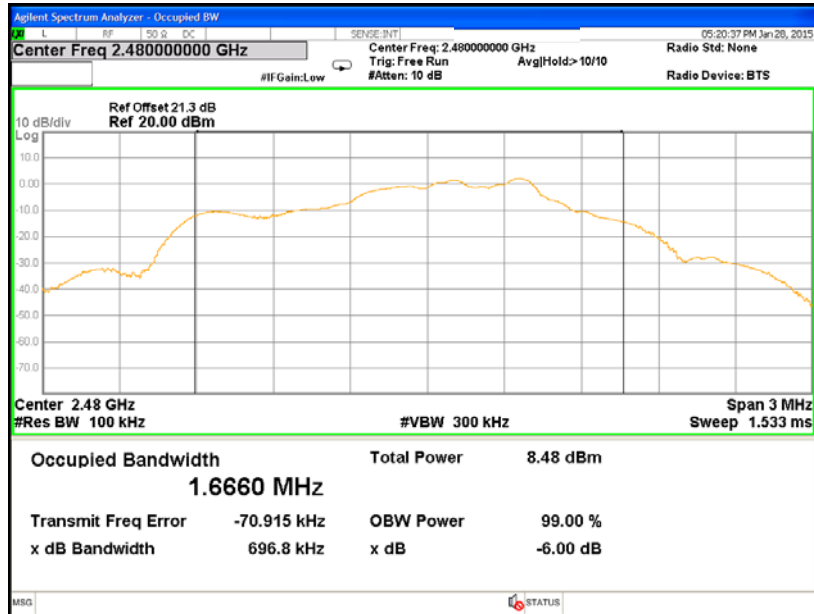

4. Maximum Peak Conducted Output Power

4.1 Operating environment

Temperature:	25	°C
Relative Humidity:	50	%
Atmospheric Pressure	1008	hPa
Requirement & Test method	15.247(b)(3) KDB 558074 D01 v03r02	
Channel number	Low, Middle, High	

4.2 Limit for maximum peak conducted output power

For systems using digital modulation in the 2400-2483.5 MHz: 1 Watt (30dBm)

4.3 Measuring instrument setting

Power meter	
Power meter	Setting
Bandwidth	65MHz bandwidth is greater than the EUT emission bandwidth
Detector	Peak & Average

4.4 Test procedure

Test procedures refer to clause 9.1.2 peak power meter method and clause 9.2.3.2 measurement using a gated RF average power meter of KDB 558074 D01.

The total conducted output power shall be reduced by 1 dB below the specified limits for each 3 dB that the directional gain of the antenna/antenna array exceeds 6 dBi. The limit is 29.5 dBm because the antenna gain is 6.5 dBi.

4.5 Test diagram

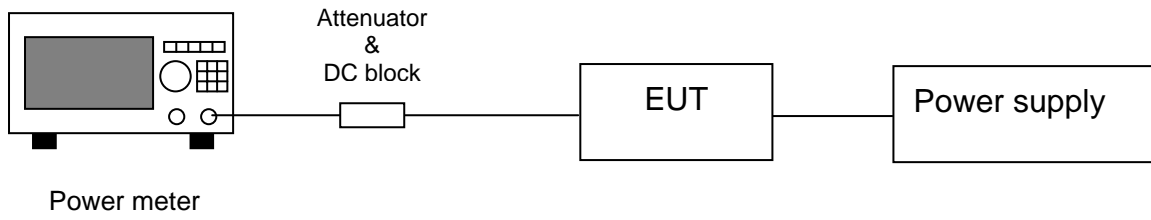

4.6 Test result

Mode	Channel	Frequency (MHz)	Output Power (AV) (dBm)	Total Power (AV) (mW)	Maximum power (PK) (dBm)	Maximum power (PK) (mW)	Limit (dBm)	Margin (dB)
BT 4.0	Low	2402	2.15	1.64	3.62	2.30144	29.5	-25.88
	Middle	2442	2.43	1.75	3.74	2.36592	29.5	-25.76
	High	2480	2.27	1.69	3.65	2.31739	29.5	-25.85

5. Power Spectral Density

5.1 Operating environment

Temperature:	25	°C
Relative Humidity:	50	%
Atmospheric Pressure	1008	hPa
Requirement & Test method	15.247(e) KDB 558074 D01 v03r02	
Channel number	Low, Middle, High	

5.2 Limit for power spectrum density

For digitally modulated systems, the power spectral density conducted from the intentional radiator to the antenna shall not be greater than 8 dBm in any 3 kHz band during any time interval of continuous transmission

5.3 Measuring instrument setting

Spectrum analyzer settings	
Spectrum Analyzer function	Setting
Detector	Peak
RBW	$3 \text{ kHz} \leq \text{RBW} \leq 100 \text{ kHz}$
VBW	$\geq 3 \times \text{RBW}$
Sweep	Auto couple
Trace	Max hold
Span	1.5 times x 6dB bandwidth
Attenuation	Auto

5.4 Test procedure

1. Test procedure refers to clause 10.2 method PKPSD (peak PSD) of KDB 558074 D01.
2. Using the maximum conducted output power in the fundamental emission demonstrates compliance. The EUT must be configured to transmit continuously at full power over the measurement duration.
3. Use the peak marker function to determine the maximum amplitude level within the RBW.

5.5 Test diagram

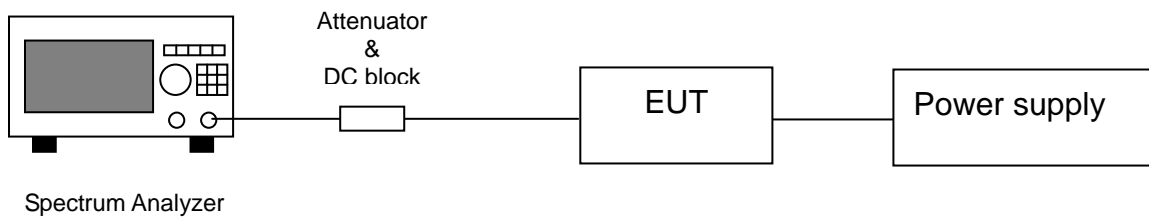

5.6 Test results

Mode	Channel	Frequency (MHz)	PSD		Limit (dBm/3kHz)	Margin (dB)
			(dBm/100kHz)	(mw/100kHz)		
BT 4.0	Low	2402	1.95	1.57	8	-6.05
	Middle	2442	1.98	1.58	8	-6.02
	High	2480	1.94	1.56	8	-6.06

Chain0: Power Density @ GFSK Mode Channel Low

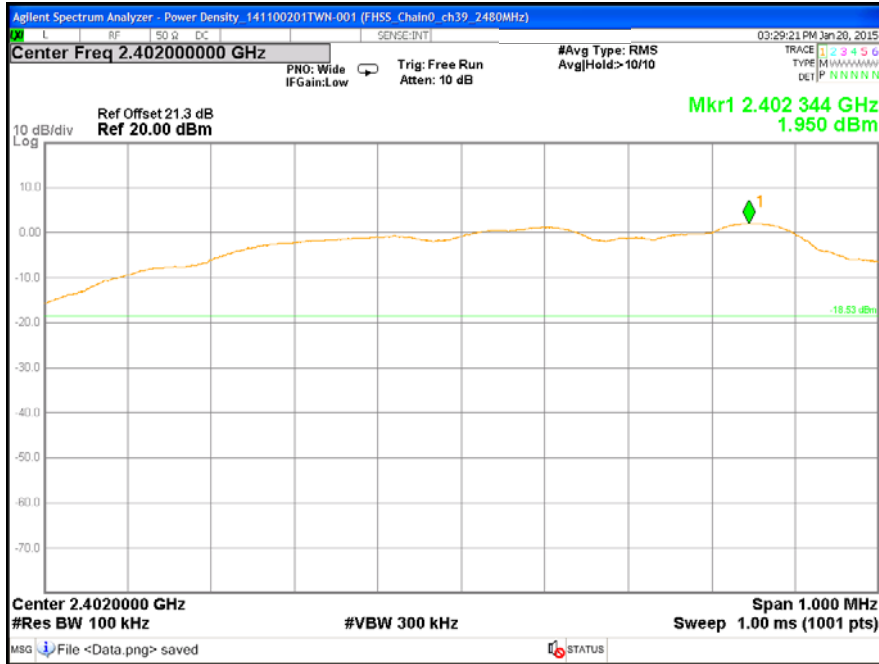

Chain0: Power Density @ GFSK Mode Channel Middle

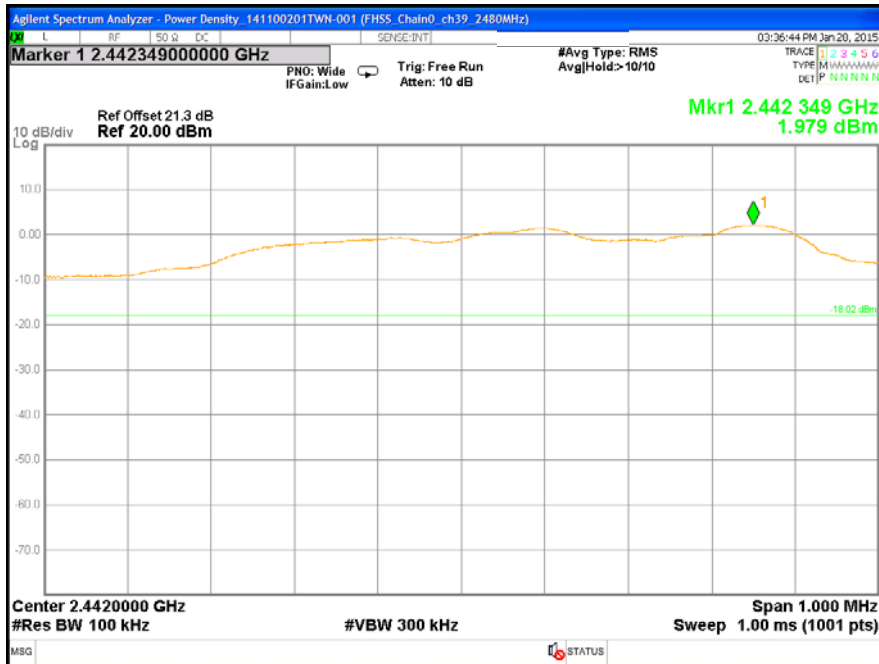

Chain0: Power Density @ GFSK Mode Channel High

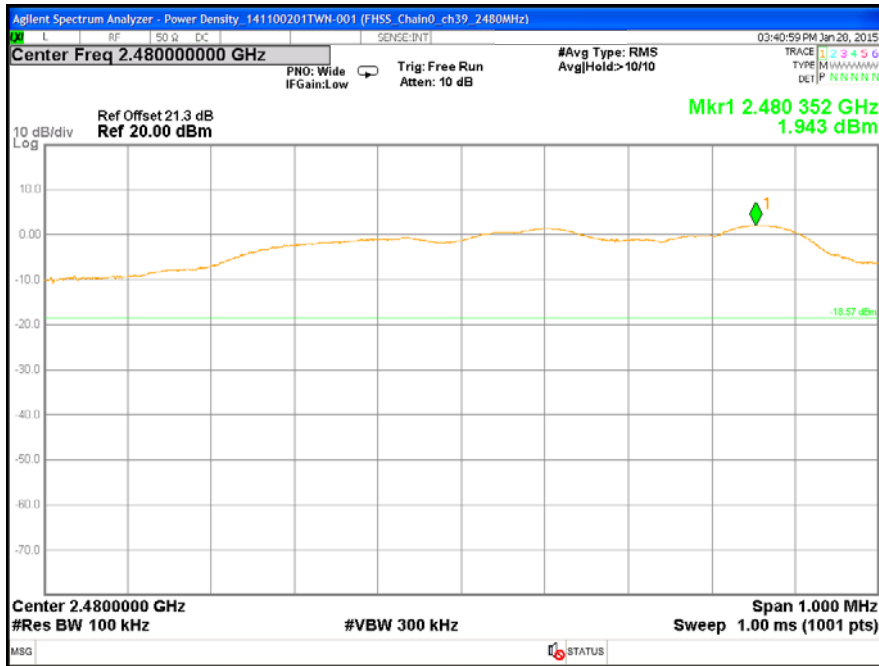

6. Emissions In Non-Restricted Frequency Bands

6.1 Operating environment

Temperature:	25	°C
Relative Humidity:	50	%
Atmospheric Pressure	1008	hPa
Requirement	15.247(d)	
Channel number	Low, Middle, High	

6.2 Limit for emissions in non-restricted frequency bands

The peak output power measured in any 100 kHz bandwidth outside of the authorized frequency band shall be attenuated by at least 20 dB relative to the maximum in-band peak PSD level in 100 kHz

6.3 Measuring instruments setting

Reference level measurement

Spectrum analyzer settings	
Spectrum Analyzer function	Setting
Detector	Peak
RBW	100 kHz
VBW	$\geq 3 \times \text{RBW}$
Sweep	Auto couple
Trace	Max hold
Span	$\geq 1.5 \text{ time } 6\text{dB bandwidth}$
Attenuation	Auto

Emission level measurement

Spectrum analyzer settings	
Spectrum Analyzer function	Setting
Detector	Peak
RBW	100 kHz
VBW	$\geq 3 \times \text{RBW}$
Sweep	Auto couple
Trace	Max hold
Attenuation	Auto

6.4 Test procedure

1. The procedure was used in antenna-port conducted and connected to the spectrum analyzer.
2. Set instrument center frequency to center frequency
3. Use the parameter configured in clause 6.3 to measure
4. Use the peak marker function to determine the maximum amplitude level.

6.5 Test diagram

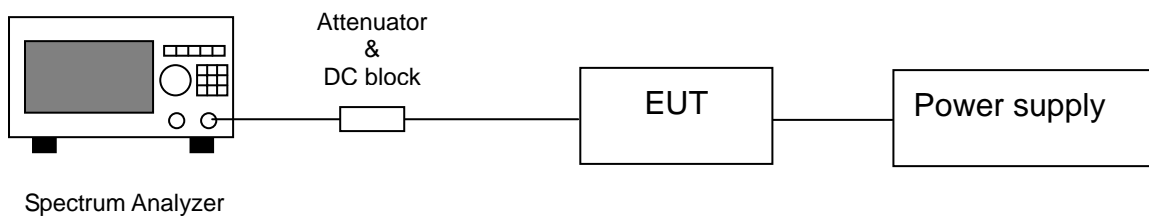

6.6 Test results

Conducted Spurious @ GFSK mode Ch0 (30M-26G)

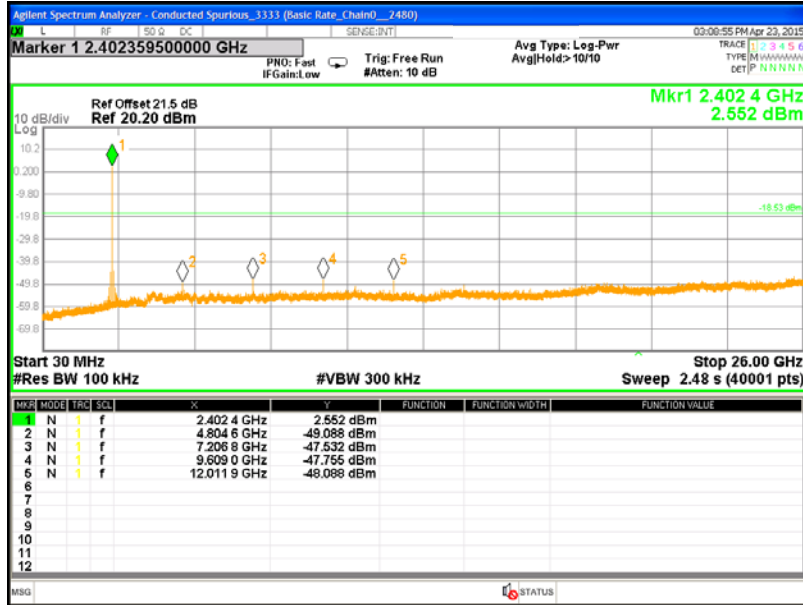

Conducted Spurious @ GFSK mode ch20 (30M-26G)

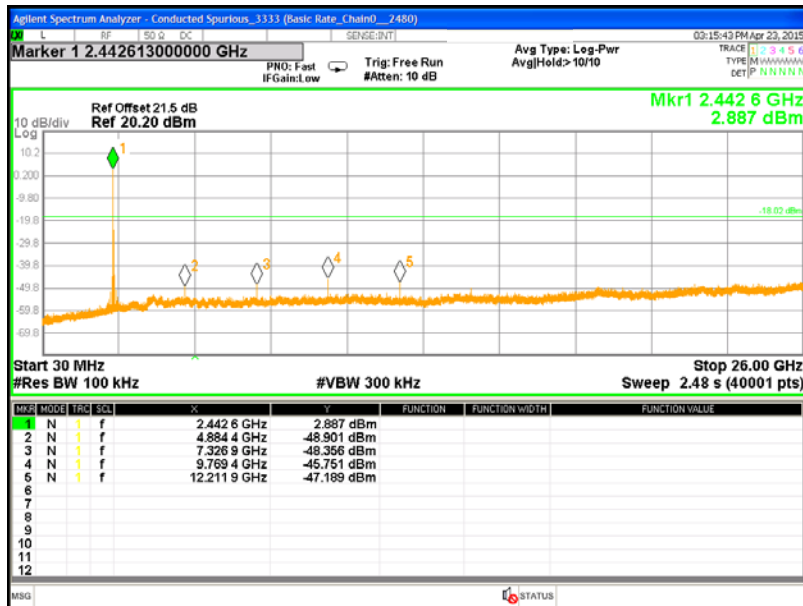

Conducted Spurious @ GFSK mode ch39 (30M-26G)

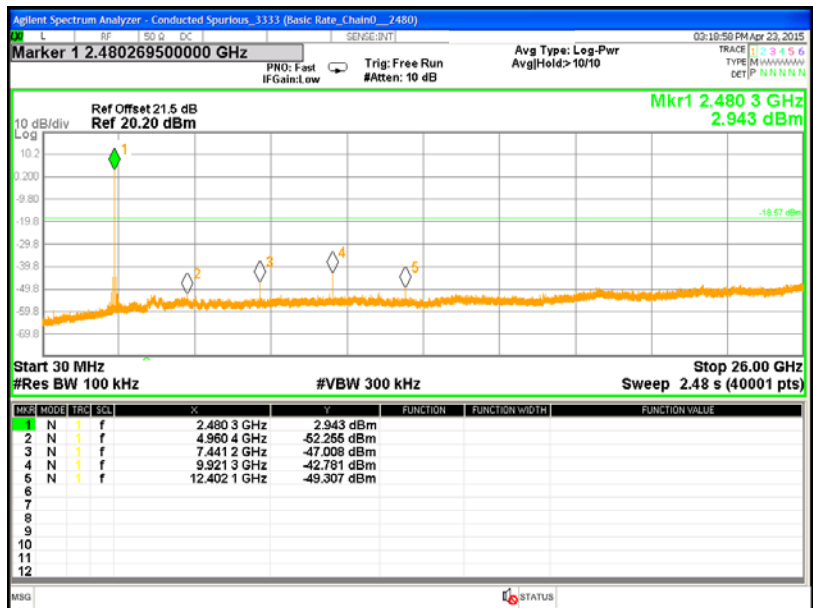

7. Emissions In Restricted Frequency Bands (Radiated emission measurements)

7.1 Operating environment

Temperature:	25	°C
Relative Humidity:	50	%
Atmospheric Pressure	1008	hPa
Requirement	15.247(d), 15.205, 15.209	
Channel number	Low, Middle, High	

7.2 Limit for emission in restricted frequency bands (Radiated emission measurement)

Frequency (MHz)	Field Strength (microvolts/meter)	Measurement distance (meters)
0.009~0.490	2400/F(kHz)	300
0.490~1.705	2400/F(kHz)	30
1.705~30	30	30
30-88	100	3
88-216	150	3
216-960	200	3
Above 960	500	3

Remark:

1. In the above table, the tighter limit applies at the band edges.
2. Distance refers to the distance in meters between the measuring instrument antenna and the closed point of any part of the device or system

7.3 Measuring instrument setting

Below 1GHz measurement

Receiver settings	
Receiver function	Setting
Detector	QP
RBW	30-1000 MHz: 120 kHz
VBW	$\geq 3 \times$ RBW
Sweep	Auto couple
Attenuation	Auto

Above 1GHz measurement

Spectrum analyzer settings	
Spectrum Analyzer function	Setting
Detector	Peak
RBW	1MHz
VBW	3MHz for Peak; 10Hz for Average
Sweep	Auto couple
Start Frequency	1GHz
Stop Frequency	Tenth harmonic
Attenuation	Auto

7.4 Test procedure

1. The center of the receiving antenna mounted on the top of a height-variable antenna tower was placed 3 meters far away from the turntable.
2. Power on the EUT and all the companion devices. The turntable was rotated by 360 degree to find the position of the maximum emission level.
3. The height of the receiving antenna was varied between one meter and four meters above ground to find the maximum emission field strength of the both horizontal and vertical polarization.
4. If find the frequencies above the limit or below within 3dB, the antenna tower was scan (from 1m to 4m) and then the turntable was rotated to find the maximum reading. For testing above 1GHz, we keep the measurement antenna aimed at the EUT.
5. Set the test-receiver system to peak or CISPR quasi-peak detector with specified bandwidth under maximum hold mode.
6. For emissions above 1GHz, use 1MHz VBW and 3MHz RBW for peak reading. Then 1MHz RBW and 10Hz VBW for average reading in spectrum analyzer.
7. If the emissions level of the EUT in peak mode was 3dB lower than the average limit specified then testing will be stopped and peak values of the EUT will be reported. Otherwise, the emissions which do not have 3dB margin will be measured using the quasi-peak method for below 1GHz.
8. For testing above 1GHz, The emissions level of the EUT in peak mode was lower than average limit, then testing will be stopped and peak values of the EUT will be reported, otherwise, the emission will be measured in average mode again and reported.

7.5 Test configuration

7.5.1 Radiated emission 9kHz ~ 30MHz using loop Antenna

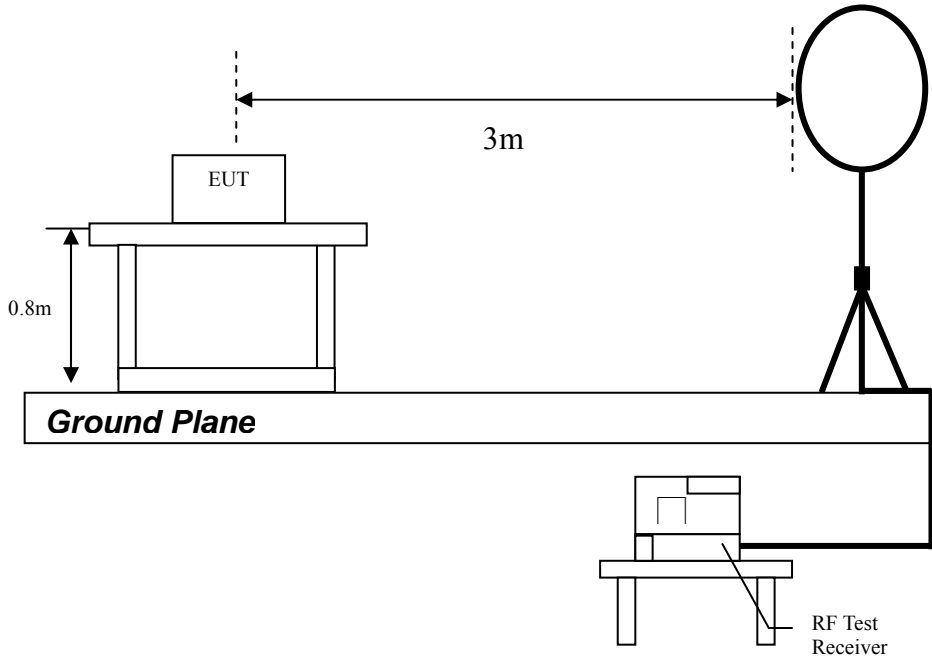

7.5.2 Radiated emission below 1GHz using Bilog Antenna

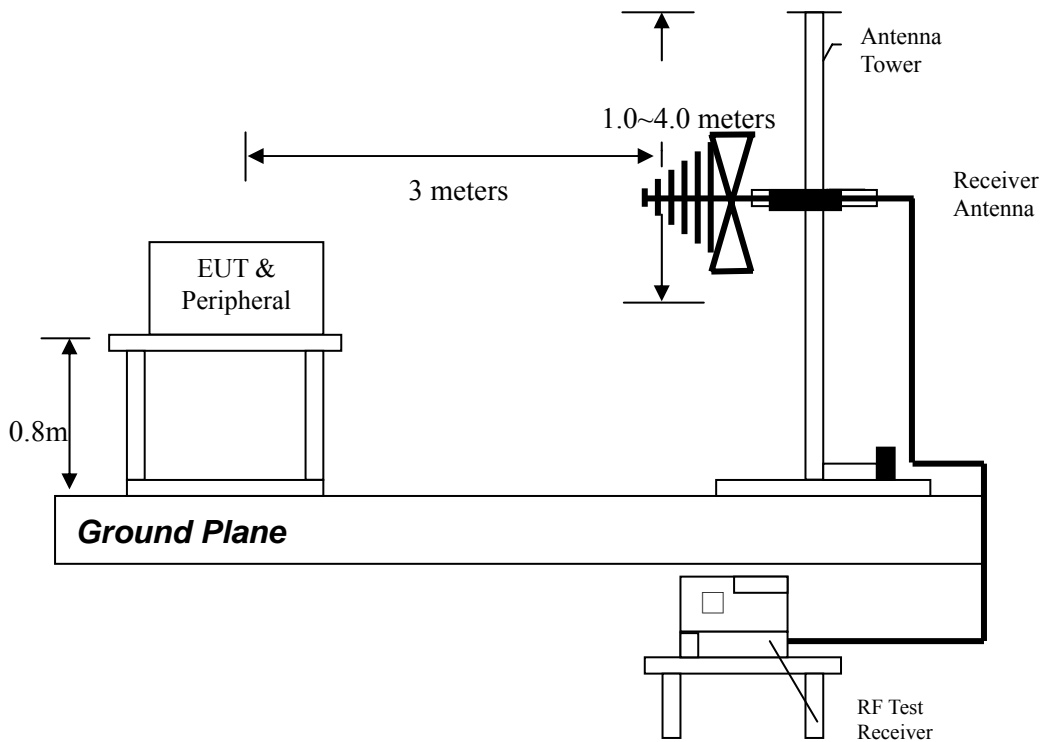

7.5.3 Radiated emission above 1GHz using Horn Antenna

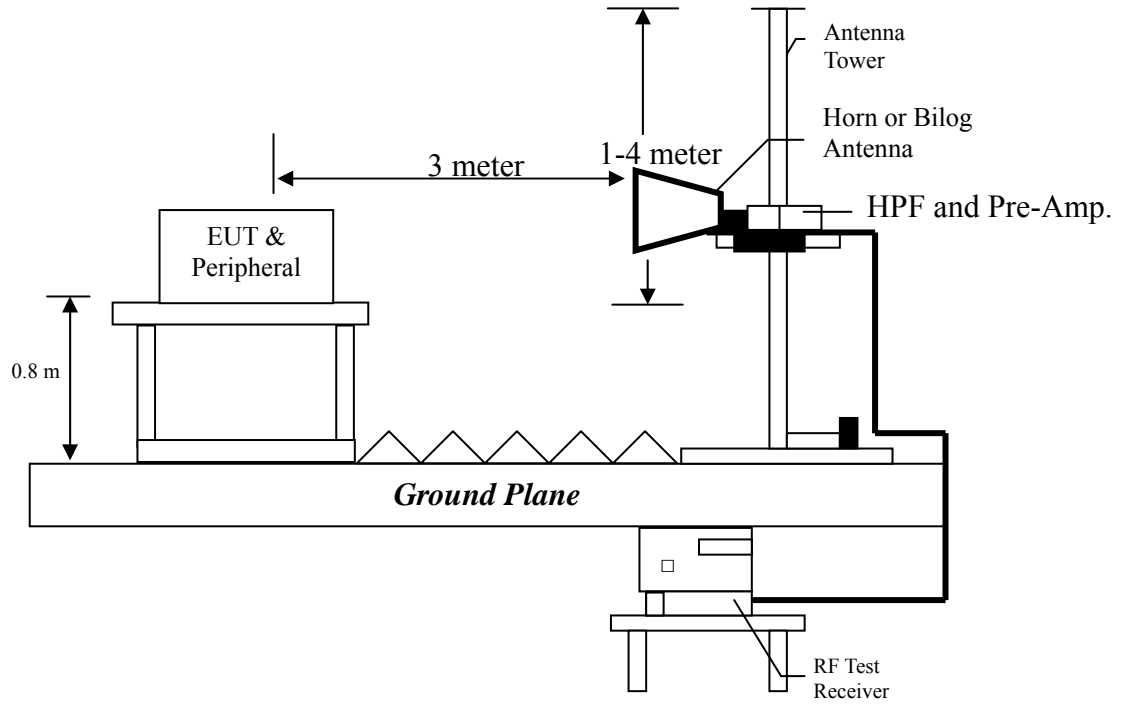

7.6 Test result

7.6.1 Measurement results: frequencies 9kHz ~ 30MHz

The test was performed on EUT continuously transmitting mode.

EUT : SM-MI-250
 Worst Case : BT4.0 Tx channel Low

Frequency (MHz)	Detection Type	factor (dB/m)	Reading Value (dBμV)	Corrected level (dBμV/m)	Limit @ 3m (dBμV/m)	Tolerance (dB)
2.15	QP	18.17	32.36	50.53	69.54	-19.01
16.36	QP	7.15	18.22	25.37	69.54	-44.17
20.00	QP	6.60	14.06	20.66	69.54	-48.88
2.06	QP	18.58	30.96	49.54	69.54	-20.00
14.48	QP	7.44	17.14	24.58	69.54	-44.96
21.10	QP	6.57	13.60	20.17	69.54	-49.37

Remark: Corr. Factor = Antenna Factor + Cable Loss - PreAmplifier Gain

7.6.2 Measurement results: frequencies below 1 GHz

The test was performed on EUT continuously transmitting mode. The worst case occurred at chain 0: BT4.0 Tx channel 20/ 2442MHz.

EUT : SM-MI-250
Worst Case : BT4.0 Tx channel Low

Antenna Polariz. (V/H)	Freq. (MHz)	Receiver Detector	Corr. Factor (dB/m)	Reading (dBμV)	Corrected Level (dBμV/m)	Limit @ 3 m (dBμV/m)	Margin (dB)
V	142.52	QP	16.16	26.93	43.09	43.50	-0.41
V	191.02	QP	13.98	22.67	36.65	43.50	-6.85
V	239.52	QP	15.68	18.86	34.54	46.00	-11.46
V	288.02	QP	17.06	17.81	34.87	46.00	-11.13
V	505.30	QP	22.13	16.62	38.75	46.00	-7.25
V	528.58	QP	22.60	16.46	39.06	46.00	-6.94
H	142.52	QP	15.15	28.11	43.26	43.50	-0.24
H	262.80	QP	17.26	25.37	42.63	46.00	-3.37
H	288.02	QP	17.70	19.04	36.74	46.00	-9.26
H	383.08	QP	19.37	19.30	38.67	46.00	-7.33
H	505.30	QP	21.51	14.72	36.23	46.00	-9.77
H	530.52	QP	21.95	15.91	37.86	46.00	-8.14

Remark:

1. Corr. Factor = Antenna Factor + Cable Loss
2. Corrected Level = Reading + Corr. Factor

Note: The amplitude of spurious emissions that are attenuated by more than 20dB below the permissible value has no need to be reported.

7.6.3 Measurement results: frequency from 1GHz to 25GHz

EUT : SM-MI-250
Test Condition : BT4.0 Tx channel Low

Mode	Freq. (MHz)	Spectrum Analyzer Detector	Ant. Pol. (H/V)	Preamp. Gain (dB)	Correction Factor (dB/m)	Reading (dBμV)	Corrected Reading (dBμV/m)	Limit @ 3 m (dBμV/m)	Margin (dB)
Channel Low	4804	PK	V	40.13	-0.10	67.99	67.89	74.00	-6.11
	4804	AV	V	40.13	-0.10	38.74	38.64	54.00	-15.36
	4980	PK	V	39.81	0.48	46.60	47.08	74.00	-26.92
	7206	PK	V	38.11	8.10	42.92	51.02	74.00	-22.98
	9608	PK	V	38.13	11.38	41.36	52.74	74.00	-21.26
	12010	PK	V	38.82	13.18	37.35	50.53	74.00	-23.47
	4804	PK	H	40.13	-0.10	57.94	57.84	74.00	-16.16
	4804	AV	H	40.13	-0.10	32.93	32.83	54.00	-21.17
	4980	PK	H	39.81	0.48	44.76	45.24	74.00	-28.76
	7206	PK	H	38.11	8.10	39.53	47.63	74.00	-26.37
	9608	PK	H	38.13	11.38	37.69	49.07	74.00	-24.93
	12010	PK	H	38.82	13.18	38.12	51.30	74.00	-22.70
Channel Middle	4884	PK	V	39.99	0.16	63.52	63.68	74.00	-10.32
	4884	AV	V	39.99	0.16	34.83	34.99	54.00	-19.01
	4980	PK	V	39.81	0.48	46.64	47.12	74.00	-26.88
	7326	PK	V	38.01	8.47	50.94	59.41	74.00	-14.59
	7326	AV	V	38.01	8.47	25.49	33.96	54.00	-20.04
	9768	PK	V	38.36	11.22	49.59	60.81	74.00	-13.19
	9768	AV	V	38.36	11.22	23.41	34.63	54.00	-19.37
	12210	PK	V	38.65	13.18	40.35	53.53	74.00	-20.47
	4884	PK	H	39.99	0.16	54.65	54.81	74.00	-19.19
	4884	AV	H	39.99	0.16	31.14	31.30	54.00	-22.70
	4980	PK	H	39.81	0.48	44.71	45.19	74.00	-28.81
	7326	PK	H	38.01	8.47	47.95	56.42	74.00	-17.58
	7326	AV	H	38.01	8.47	24.10	32.57	54.00	-21.43
	9768	PK	H	38.36	11.22	40.86	52.08	74.00	-21.92
12210	PK	H	38.65	13.18	36.90	50.08	74.00	-23.92	

Mode	Freq. (MHz)	Spectrum Analyzer Detector	Ant. Pol. (H/V)	Preamp. Gain (dB)	Correction Factor (dB/m)	Reading (dBμV)	Corrected Reading (dBμV/m)	Limit @ 3 m (dBμV/m)	Margin (dB)
Channel High	4960	PK	V	39.84	0.41	57.39	57.80	74.00	-16.20
	4960	AV	V	39.84	0.41	34.55	34.96	54.00	-19.04
	7440	PK	V	37.91	8.82	49.65	58.47	74.00	-15.53
	7440	AV	V	37.91	8.82	31.98	40.80	54.00	-13.20
	9920	PK	V	38.57	11.07	44.30	55.37	74.00	-18.63
	9920	AV	V	38.57	11.07	29.18	40.25	54.00	-13.75
	12400	PK	V	38.49	13.18	46.19	59.37	74.00	-14.63
	12400	AV	V	38.49	13.18	28.92	42.10	54.00	-11.90
	4960	PK	H	39.84	0.41	49.50	49.91	74.00	-24.09
	7440	PK	H	37.91	8.82	48.40	57.22	74.00	-16.78
	7440	AV	H	37.91	8.82	29.37	38.19	54.00	-15.81
	9920	PK	H	38.57	11.07	38.14	49.21	74.00	-24.79
	12400	PK	H	38.49	13.18	36.53	49.71	74.00	-24.29

Remark: Correction Factor = Antenna Factor + Cable Loss + High Pass Filter Loss -
 Pre_Amplifier Gain

8. Emission On Band Edge

8.1 Operating environment

Temperature:	25	°C
Relative Humidity:	50	%
Atmospheric Pressure	1008	hPa
Requirement	15.247(d), 15.205,	
Channel	37, 39	

8.2 Measuring instrument setting

Spectrum analyzer settings	
Spectrum Analyzer function	Setting
Detector	Peak
RBW	1MHz
VBW	3MHz for Peak; 10Hz for Average
Sweep	Auto couple
Restrict bands	2310~2390MHz
	2483.5 ~2500MHz
Attenuation	Auto

8.3 Test procedure

The test procedure is the same as clause 7.4

8.4 Test results

EUT : SM-MI-250
 Test Condition : BT4.0

Mode	Freq. (MHz)	Spectrum Analyzer Detector	Ant. Pol. (H/V)	Correction Factor (dB/m)	Reading (dBμV)	Corrected Reading (dBμV/m)	Limit @ 3 m (dBμV/m)	Margin (dB)	Restricted band (MHz)
BT4.0	2337.72	PK	V	33.60	27.79	61.39	74	-12.61	2310~2390
	2390.00	AV	V	33.85	12.98	46.83	54	-7.17	
	2499.55	PK	V	34.38	27.71	62.09	74	-11.91	2483.5~2500
	2483.50	AV	V	34.30	13.06	47.36	54	-6.64	

9. AC Power Line Conducted Emission

9.1 Operating environment

Temperature:	25	°C
Relative Humidity:	50	%
Atmospheric Pressure	1008	hPa
Requirement	15.207	
Date of test	Jan. 05, 2015	

9.2 Limit for AC power line conducted emission

Freq. (MHz)	Conducted Limit (dBuV)	
	Q.P.	Ave.
0.15~0.50	66 – 56*	56 – 46*
0.50~5.00	56	46
5.00~30.0	60	50

9.3 Measuring instrument setting

Receiver settings	
Receiver function	Setting
Detector	QP
Start frequency	0.15MHz
Stop frequency	30MHz
IF bandwidth	9 kHz
Attenuation	10dB

9.4 Test procedure

1. Configure the EUT according to ANSI C63.4:2014. The EUT or host of EHT has to be placed 0.4 meter far from the conducting wall of the shielding room and at least 80 centimeters from any other grounded conducting surface.
2. Connect EUT or host of EUT to the power mains through a line impedance stabilization network.
3. All the companion devices are connected to the other LISN. The LISN should provide 50U_h/50ohms coupling impedance.
4. The frequency range from 150 kHz to 30MHz was searched
5. Set the test-receiver system to peak detector and specified bandwidth with maximum hold mode.
6. The measurement has to be done between each power line and ground at the power terminal.

9.5 Test diagram

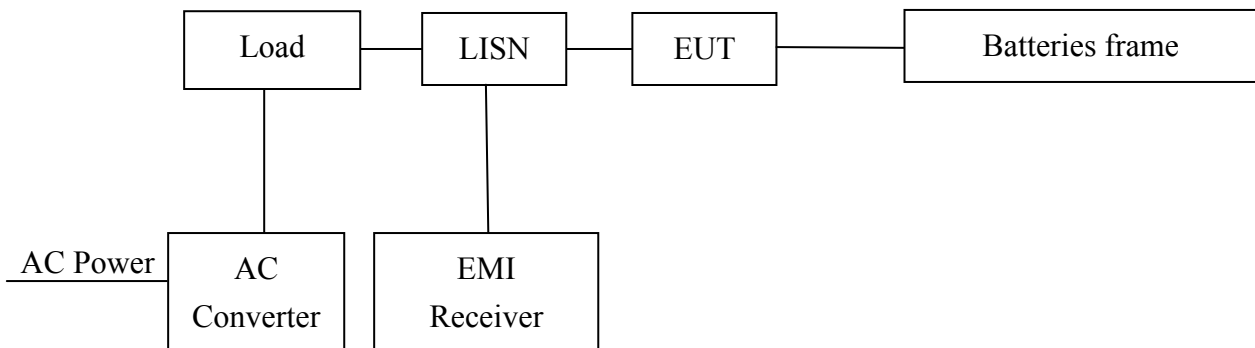

Note: The EUT was tested while in normal communication mode.

9.6 Test results

Phase : Line
 EUT : SM-MI-250
 Test Condition : TX mode
 Test Voltage : AC 240V, 60Hz

Frequency (MHz)	Corr. Factor (dB)	Level Qp (dBuV)	Limit Qp (dBuV)	Level Av (dBuV)	Limit Av (dBuV)	Over Limit (dB)	
						Qp	Av
0.152	10.00	54.54	65.87	35.89	55.87	-11.32	-19.98
0.157	10.00	53.23	65.60	39.92	55.60	-12.37	-15.68
0.220	9.97	49.32	62.83	28.67	52.83	-13.52	-24.17
0.260	9.96	54.85	61.42	50.16	51.42	-6.58	-1.27
0.783	9.96	46.77	56.00	41.13	46.00	-9.23	-4.87
1.303	9.98	47.25	56.00	41.65	46.00	-8.75	-4.35
1.829	9.99	26.37	56.00	21.99	46.00	-29.63	-24.01
8.323	10.04	47.40	60.00	42.74	50.00	-12.60	-7.26
8.592	10.04	35.71	60.00	29.48	50.00	-24.29	-20.52

Remark:

1. Corr. Factor (dB) = LISN Factor (dB) + Cable Loss (dB)
2. Over Limit (dB) = Level (dBuV) – Limit (dBuV)

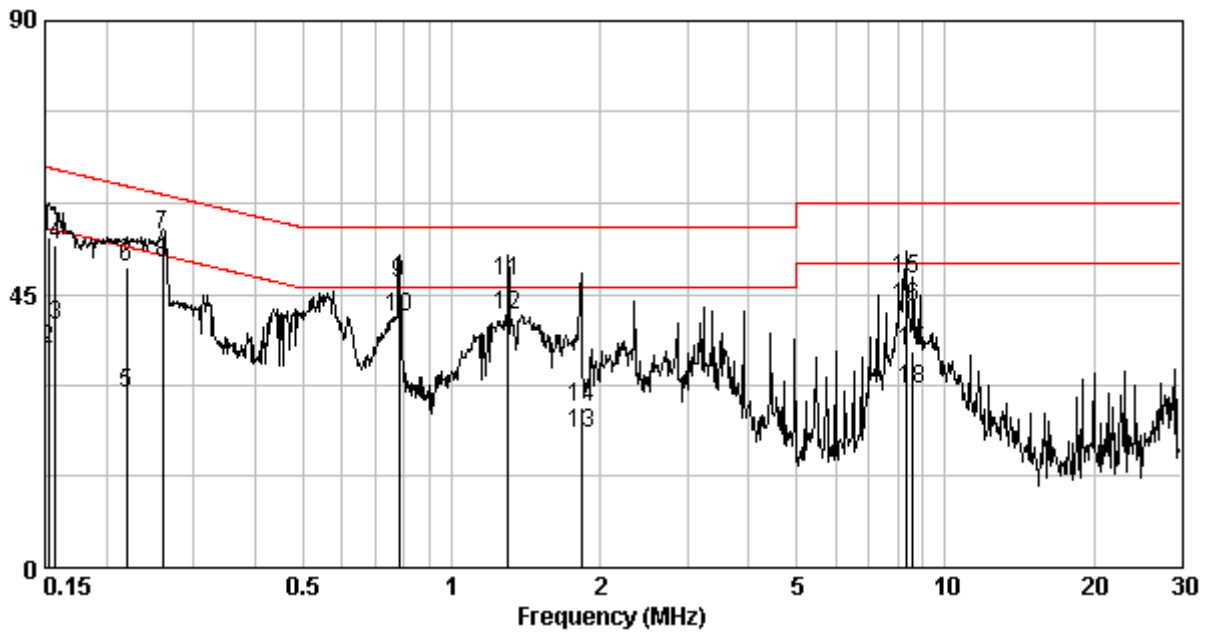

Phase : Neutral
 EUT : SM-MI-250
 Test Condition : TX mode
 Test Voltage : AC 240V, 60Hz

Frequency (MHz)	Corr. Factor (dB)	Level Qp (dBuV)	Limit Qp (dBuV)	Level Av (dBuV)	Limit Av (dBuV)	Over Limit Qp (dB)	Over Limit Av (dB)
0.151	9.93	53.44	65.96	33.50	55.96	-12.52	-22.45
0.154	9.93	52.67	65.78	34.35	55.78	-13.11	-21.43
0.224	9.93	48.96	62.66	27.90	52.66	-13.69	-24.76
0.260	9.92	55.19	61.42	50.72	51.42	-6.24	-0.70
0.592	9.91	40.28	56.00	23.09	46.00	-15.72	-22.91
0.783	9.94	42.98	56.00	37.39	46.00	-13.02	-8.61
1.310	9.97	34.23	56.00	23.76	46.00	-21.77	-22.24
1.829	9.97	26.60	56.00	22.42	46.00	-29.40	-23.58
8.062	10.01	48.49	60.00	41.88	50.00	-11.51	-8.12
8.323	10.01	49.46	60.00	43.20	50.00	-10.54	-6.80

Remark:

1. Corr. Factor (dB) = LISN Factor (dB) + Cable Loss (dB)
2. Over Limit (dB) = Level (dBuV) – Limit (dBuV)

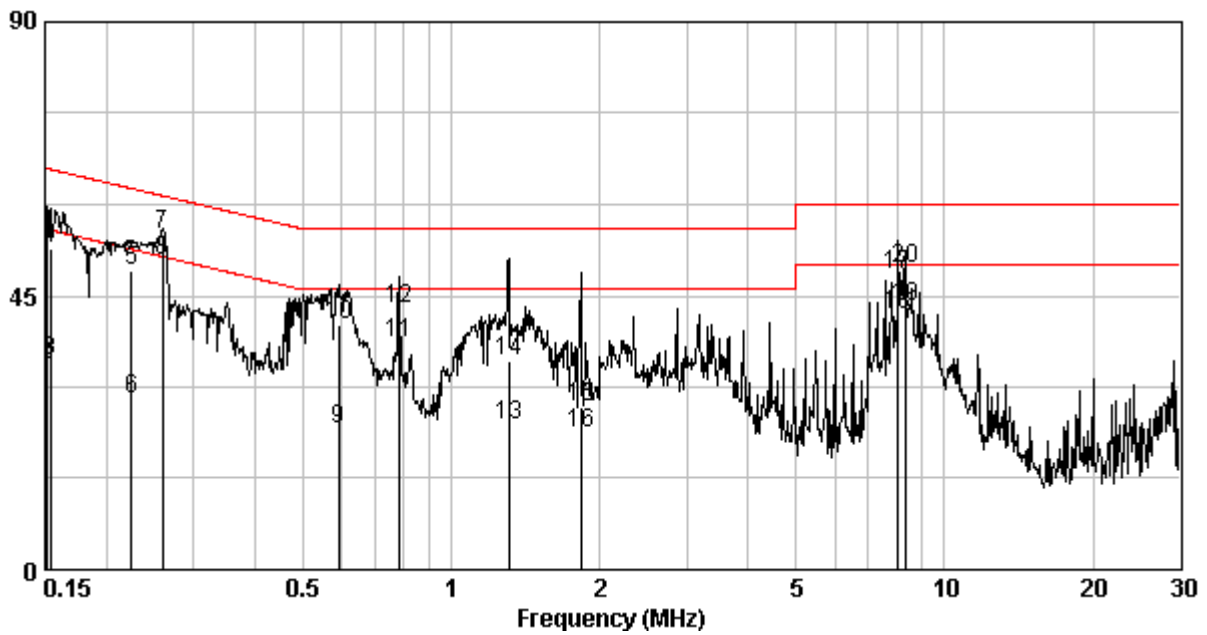

Appendix A: Test equipment list

Equipment	Brand	Model No.	Serial No.	Calibration Date	Next Calibration Date
ESCI EMI Test Receiver	Rohde & Schwarz	ESCI	100018	2014/12/02	2015/12/01
Spectrum Analyzer	Rohde & Schwarz	FSP30	100137	2014/06/16	2015/06/15
Horn Antenna (1-18G)	Schwarzbeck	BBHA 9120 D	9120D-456	2014/08/29	2017/08/27
Horn Antenna (14-42G)	SHWARZBECK	BBHA 9170	BBHA9170159	2014/09/16	2017/09/14
Broadband Antenna	Schwarzbeck	VULB 9168	9168-172	2013/08/08	2015/08/07
Pre-Amplifier	MITEQ	AFS44-00102650 --42-10P-44	1495287	2013/10/27	2015/10/26
Pre-Amplifier	MITEQ	JS4-26004000--2 7-8A	828825	2014/09/15	2015/09/14
Power Meter	Anritsu	ML2495A	0844001	2014/11/12	2015/11/11
Power Sensor	Anritsu	MA2411B	0738452	2014/11/12	2015/11/11
Two-Line V-Network	Rohde & Schwarz	ESH3-Z5	838979/014	2014/10/05	2015/10/04
Singal Analyzer	Agilent	N9030A	MY51380492	2014/09/19	2015/09/18
Loop Antenna	RolfHeine	LA-285	02/10033	2014/3/18	2016/03/16
966-2(A) Cable	SUHNER	SMA / EX 100	N/A	2014/05/6	2015/05/05
966-2(B) Cable	JUNFLON	SMA / J12J100880-00	AUG-26-08-002	2014/05/06	2015/05/05
966-2_3m Semi-Anechoic Chamber	966_2	CEM-966_2	N/A	2015/02/24	2016/02/23

Appendix B: Measurement Uncertainty

This uncertainty represents an expanded uncertainty expressed at approximately the 95 % confidence level using a coverage factor of $k=2$.

Item	Uncertainty
Vertically polarized radiated disturbances from 30MHz~1GHz in a semi-anechoic chamber at a distance of 3m	5.15 dB
Horizontally polarized radiated disturbances from 30MHz~1GHz in a semi-anechoic chamber at a distance of 3m	5.23 dB
Vertically polarized Radiated disturbances from 1GHz~18GHz in a semi-anechoic chamber at a distance of 3m	4.19 dB
Horizontally polarized Radiated disturbances from 1GHz~18GHz in a semi-anechoic chamber at a distance of 3m	4.3 dB
Vertically polarized Radiated disturbances from 18GHz~40GHz in a semi-anechoic chamber at a distance of 3m	4.19 dB
Horizontally polarized Radiated disturbances from 18GHz~40GHz in a semi-anechoic chamber at a distance of 3m	4.3 dB
Conducted Output power	0.86 dB
Radiated electromagnetic disturbances in the frequency range from 9kHz to 30MHz	2.92 dB
Conducted disturbance measurements at a mains port from 9 kHz to 30 MHz using a 50 Ω /50 μ H +5 Ω artificial mains network (AMN)	2.5dB