



MET Laboratories, Inc. *Safety Certification - EMI - Telecom Environmental Simulation*

914 WEST PATAPSCO AVENUE • BALTIMORE, MARYLAND 21230-3432 • PHONE (410) 354-3300 • FAX (410) 354-3313

33439 WESTERN AVENUE • UNION CITY, CALIFORNIA 94587 • PHONE (510) 489-6300 • FAX (510) 489-6372

3162 BELICK STREET • SANTA CLARA, CALIFORNIA 95054 • PHONE (408) 748-3585 • FAX (510) 489-6372

December 27, 2011

Ubiquiti Networks
91 E. Tasman
San Jose, CA 95134

Dear Jennifer Sanchez,

Enclosed is the EMC Wireless test report for compliance testing of the Ubiquiti Networks, PowerBridgeM5 as tested to the requirements of Title 47 of the CFR, Ch. 1 (10-1-06 ed.), Part 15, Subpart B, ICES-003, Issue 4 February 2004 for a Class A Digital Device and FCC Part 15 Subpart C, RSS-210, Issue 8, Dec. 2010 for Intentional Radiators.

Thank you for using the services of MET Laboratories, Inc. If you have any questions regarding these results or if MET can be of further service to you, please feel free to contact me.

Sincerely yours,
MET LABORATORIES, INC.

Jennifer Warnell
Documentation Department

Reference: (\\Ubiquiti Networks\EMCS83055-FCC247 Rev. 2)

Certificates and reports shall not be reproduced except in full, without the written permission of MET Laboratories, Inc.

Electromagnetic Compatibility Criteria Test Report

for the

**Ubiquiti Networks
PowerBridgeM5**

Tested under
the FCC Certification Rules
contained in
Title 47 of the CFR, Parts 15 Subpart B & ICES-003
for Class A Digital Devices
&
15.247 Subpart C & RSS-210, Issue 8, Dec. 2010
for Intentional Radiators

MET Report: EMCS83055-FCC247 Rev. 2

December 27, 2011

Prepared For:

**Ubiquiti Networks
91 E. Tasman
San Jose, CA 95134**

Prepared By:
MET Laboratories, Inc.
3162 Belick St.
Santa Clara, CA 95054

Electromagnetic Compatibility Criteria Test Report

for the

Ubiquiti Networks PowerBridgeM5

Tested under
the FCC Certification Rules
contained in
Title 47 of the CFR, Parts 15 Subpart B & ICES-003
for Class A Digital Devices
&
15.247 Subpart C & RSS-210, Issue 8, Dec. 2010
for Intentional Radiators



Lionel Gabrillo, Project Engineer
Electromagnetic Compatibility Lab



Jennifer Warnell
Documentation Department

Engineering Statement: The measurements shown in this report were made in accordance with the procedures indicated, and the emissions from this equipment were found to be within the limits applicable. I assume full responsibility for the accuracy and completeness of these measurements, and for the qualifications of all persons taking them. It is further stated that upon the basis of the measurements made, the equipment tested is capable of operation in accordance with the requirements of the FCC Rules Parts 15B, 15.247 and Industry Canada standards ICES-003, Issue 4 February 2004, RSS-210, Issue 8, Dec. 2010 under normal use and maintenance.



Shawn McMillen,
Wireless Manager, Electromagnetic Compatibility Lab

Report Status Sheet

Revision	Report Date	Reason for Revision
∅	June 2, 2011	Initial Issue.
1	June 30, 2011	Revised to reflect engineer corrections.
2	December 27, 2011	Revised to reflect engineer corrections.

Table of Contents

I.	Executive Summary	1
	A. Purpose of Test	2
	B. Executive Summary	2
II.	Equipment Configuration	3
	A. Overview.....	4
	B. References.....	5
	C. Test Site	5
	D. Description of Test Sample.....	6
	E. Equipment Configuration.....	8
	F. Support Equipment	8
	G. Ports and Cabling Information.....	8
	H. Mode of Operation.....	9
	I. Method of Monitoring EUT Operation	9
	J. Modifications	9
	a) Modifications to EUT.....	9
	b) Modifications to Test Standard.....	9
	K. Disposition of EUT	9
III.	Electromagnetic Compatibility Criteria for Unintentional Radiators	10
	§ 15.107(a) Conducted Emissions Limits.....	11
	§ 15.109(a) Radiated Emissions Limits.....	15
IV.	Electromagnetic Compatibility Criteria for Intentional Radiators	19
	§ 15.203 Antenna Requirement	20
	§ 15.207(a) Conducted Emissions Limits.....	21
	§ 15.247(a)(a) 6 dB and 99% Bandwidth	25
	§ 15.247(b) Peak Power Output	56
	§ 15.247(d) Radiated Spurious Emissions Requirements and Band Edge.....	58
	§ 15.247(d) RF Conducted Spurious Emissions Requirements and Band Edge.....	136
	§ 15.247(e) Peak Power Spectral Density	179
	§ 15.247(i) Maximum Permissible Exposure	196
	RSS-GEN Receiver Spurious Emissions.....	197
V.	Test Equipment	200
VI.	Certification & User's Manual Information	202
	A. Certification Information	203
	B. Label and User's Manual Information	207
VII.	ICES-003 Procedural & Labeling Requirements.....	209

List of Tables

Table 1. Executive Summary of EMC Part 15.247 Compliance Testing	2
Table 2. EUT Summary Table.....	4
Table 3. References	5
Table 4. Equipment Configuration	8
Table 5. Support Equipment.....	8
Table 6. Ports and Cabling Information	8
Table 7. Conducted Limits for Radio Frequency Devices calculated from FCC Part 15 Subsections 15.107(a) (b) and 15.207(a)	11
Table 8. Conducted Emissions - Voltage, AC Power, Phase Line (120 VAC, 60 Hz).....	12
Table 9. Conducted Emissions - Voltage, AC Power, Neutral Line (120 VAC, 60 Hz)	13
Table 10. Radiated Emissions Limits calculated from FCC Part 15, §15.109 (a) (b)	15
Table 11. Radiated Emissions Limits, Test Results, 30 MHz – 1 GHz, FCC Limits	16
Table 12. Radiated Emissions Limits, Test Results, ICES-003 Limits	17
Table 13. Antenna List	20
Table 14. Conducted Limits for Intentional Radiators from FCC Part 15 § 15.207(a)	21
Table 15. Conducted Emissions, 15.207(a), Phase Line, Test Results	22
Table 16. Conducted Emissions, 15.207(a), Neutral Line, Test Results	23
Table 17. 6 dB Occupied Bandwidth, Test Results	26
Table 18. 99% Occupied Bandwidth, Test Results	27
Table 19. Output Power Requirements from §15.247(b)	56
Table 20. Peak Power Output, Test Results	57
Table 21. Restricted Bands of Operation.....	58
Table 22. Radiated Emissions Limits Calculated from FCC Part 15, § 15.209 (a)	59
Table 23. Radiated Spurious Emissions, Test Results, HT5, Low Channel	72
Table 24. Radiated Spurious Emissions, Test Results, HT5, Mid Channel.....	75
Table 25. Radiated Spurious Emissions, Test Results, HT5, High Channel	78
Table 26. Radiated Spurious Emissions, Test Results, HT8, Low Channel	81
Table 27. Radiated Spurious Emissions, Test Results, HT8, Mid Channel.....	84
Table 28. Radiated Spurious Emissions, Test Results, HT8, High Channel	87
Table 29. Radiated Spurious Emissions, Test Results, HT10, Low Channel	90
Table 30. Radiated Spurious Emissions, Test Results, HT10, Mid Channel.....	93
Table 31. Radiated Spurious Emissions, Test Results, HT10, High Channel	96
Table 32. Radiated Spurious Emissions, Test Results, HT20, Low Channel	99
Table 33. Radiated Spurious Emissions, Test Results, HT20, Mid Channel.....	102
Table 34. Radiated Spurious Emissions, Test Results, HT20, High Channel	105
Table 35. Radiated Spurious Emissions, Test Results, HT30, Low Channel.....	108
Table 36. Radiated Spurious Emissions, Test Results, HT30, Mid Channel.....	111
Table 37. Radiated Spurious Emissions, Test Results, HT30, High Channel	114
Table 38. Radiated Spurious Emissions, Test Results, HT40, Low Channel	117
Table 39. Radiated Spurious Emissions, Test Results, HT40, Mid Channel.....	120
Table 40. Radiated Spurious Emissions, Test Results, HT40, High Channel	123
Table 41. Peak Power Spectral Density, Test Results	180
Table 42. Peak Power Spectral Density, Summed	181
Table 43. Spurious Emission Limits for Receivers	197
Table 44. Test Equipment List	201

List of Plots

Plot 1. Conducted Emission, Phase Line Plot	12
Plot 2. Conducted Emission, Neutral Line Plot.....	13
Plot 3. Radiated Emissions, 30 MHz - 1 GHz, FCC Limits	16
Plot 4. Radiated Emissions, ICES-003 Limits.....	17
Plot 5. Conducted Emissions, 15.207(a), Phase Line	22
Plot 6. Conducted Emissions, 15.207(a), Neutral Line	23
Plot 7. 6 dB Occupied Bandwidth, 802.11a 20 MHz, Low Channel	28
Plot 8. 6 dB Occupied Bandwidth, 802.11a 20 MHz, Mid Channel.....	28
Plot 9. 6 dB Occupied Bandwidth, 802.11a 20 MHz, High Channel	28
Plot 10. 6 dB Occupied Bandwidth, 802.11a 40 MHz, Low Channel.....	29
Plot 11. 6 dB Occupied Bandwidth, 802.11a 40 MHz, Mid Channel.....	29
Plot 12. 6 dB Occupied Bandwidth, 802.11a 40 MHz, High Channel	29
Plot 13. 6 dB Occupied Bandwidth, HT5, Port 1, Low Channel.....	30
Plot 14. 6 dB Occupied Bandwidth, HT5, Port 1, Mid Channel	30
Plot 15. 6 dB Occupied Bandwidth, HT5, Port 1, High Channel	30
Plot 16. 6 dB Occupied Bandwidth, HT5, Port 2, Low Channel.....	31
Plot 17. 6 dB Occupied Bandwidth, HT5, Port 2, Mid Channel	31
Plot 18. 6 dB Occupied Bandwidth, HT5, Port 2, High Channel	31
Plot 19. 6 dB Occupied Bandwidth, HT8, Port 1, Low Channel.....	32
Plot 20. 6 dB Occupied Bandwidth, HT8, Port 1, Mid Channel	32
Plot 21. 6 dB Occupied Bandwidth, HT8, Port 1, High Channel	32
Plot 22. 6 dB Occupied Bandwidth, HT8, Port 2, Low Channel.....	33
Plot 23. 6 dB Occupied Bandwidth, HT8, Port 2, Mid Channel	33
Plot 24. 6 dB Occupied Bandwidth, HT8, Port 2, High Channel	33
Plot 25. 6 dB Occupied Bandwidth, HT10, Port 1, Low Channel.....	34
Plot 26. 6 dB Occupied Bandwidth, HT10, Port 1, Mid Channel	34
Plot 27. 6 dB Occupied Bandwidth, HT10, Port 1, High Channel	34
Plot 28. 6 dB Occupied Bandwidth, HT10, Port 2, Low Channel.....	35
Plot 29. 6 dB Occupied Bandwidth, HT10, Port 2, Mid Channel	35
Plot 30. 6 dB Occupied Bandwidth, HT10, Port 2, High Channel	35
Plot 31. 6 dB Occupied Bandwidth, HT20, Port 1, Low Channel.....	36
Plot 32. 6 dB Occupied Bandwidth, HT20, Port 1, Mid Channel	36
Plot 33. 6 dB Occupied Bandwidth, HT20, Port 1, High Channel	36
Plot 34. 6 dB Occupied Bandwidth, HT20, Port 2, Low Channel.....	37
Plot 35. 6 dB Occupied Bandwidth, HT20, Port 2, Mid Channel	37
Plot 36. 6 dB Occupied Bandwidth, HT20, Port 2, High Channel	37
Plot 37. 6 dB Occupied Bandwidth, HT30, Port 1, Low Channel.....	38
Plot 38. 6 dB Occupied Bandwidth, HT30, Port 1, Mid Channel	38
Plot 39. 6 dB Occupied Bandwidth, HT30, Port 1, High Channel	38
Plot 40. 6 dB Occupied Bandwidth, HT30, Port 2, Low Channel.....	39
Plot 41. 6 dB Occupied Bandwidth, HT30, Port 2, Mid Channel	39
Plot 42. 6 dB Occupied Bandwidth, HT30, Port 2, High Channel	39
Plot 43. 6 dB Occupied Bandwidth, HT40, Port 1, Low Channel.....	40
Plot 44. 6 dB Occupied Bandwidth, HT40, Port 1, Mid Channel	40
Plot 45. 6 dB Occupied Bandwidth, HT40, Port 1, High Channel	40
Plot 46. 6 dB Occupied Bandwidth, HT40, Port 2, Low Channel.....	41
Plot 47. 6 dB Occupied Bandwidth, HT40, Port 2, Mid Channel	41
Plot 48. 6 dB Occupied Bandwidth, HT40, Port 2, High Channel	41
Plot 49. 99% Occupied Bandwidth, 802.11a 20 MHz, Low Channel	42
Plot 50. 99% Occupied Bandwidth, 802.11a 20 MHz, Mid Channel	42

Plot 51. 99% Occupied Bandwidth, 802.11a 20 MHz, High Channel.....	42
Plot 52. 99% Occupied Bandwidth, 802.11a 40 MHz, Low Channel	43
Plot 53. 99% Occupied Bandwidth, 802.11a 40 MHz, Mid Channel	43
Plot 54. 99% Occupied Bandwidth, 802.11a 40 MHz, High Channel.....	43
Plot 55. 99% Occupied Bandwidth, HT5, Port 1, Low Channel	44
Plot 56. 99% Occupied Bandwidth, HT5, Port 1, Mid Channel	44
Plot 57. 99% Occupied Bandwidth, HT5, Port 1, High Channel	44
Plot 58. 99% Occupied Bandwidth, HT5, Port 2, Low Channel	45
Plot 59. 99% Occupied Bandwidth, HT5, Port 2, Mid Channel	45
Plot 60. 99% Occupied Bandwidth, HT5, Port 2, High Channel	45
Plot 61. 99% Occupied Bandwidth, HT8, Port 1, Low Channel	46
Plot 62. 99% Occupied Bandwidth, HT8, Port 1, Mid Channel	46
Plot 63. 99% Occupied Bandwidth, HT8, Port 1, High Channel	46
Plot 64. 99% Occupied Bandwidth, HT8, Port 2, Low Channel	47
Plot 65. 99% Occupied Bandwidth, HT8, Port 2, Mid Channel	47
Plot 66. 99% Occupied Bandwidth, HT8, Port 2, High Channel	47
Plot 67. 99% Occupied Bandwidth, HT10, Port 1, Low Channel	48
Plot 68. 99% Occupied Bandwidth, HT10, Port 1, Mid Channel	48
Plot 69. 99% Occupied Bandwidth, HT10, Port 1, High Channel.....	48
Plot 70. 99% Occupied Bandwidth, HT10, Port 2, Low Channel	49
Plot 71. 99% Occupied Bandwidth, HT10, Port 2, Mid Channel	49
Plot 72. 99% Occupied Bandwidth, HT10, Port 2, High Channel.....	49
Plot 73. 99% Occupied Bandwidth, HT20, Port 1, Low Channel	50
Plot 74. 99% Occupied Bandwidth, HT20, Port 1, Mid Channel	50
Plot 75. 99% Occupied Bandwidth, HT20, Port 1, High Channel.....	50
Plot 76. 99% Occupied Bandwidth, HT20, Port 2, Low Channel	51
Plot 77. 99% Occupied Bandwidth, HT20, Port 2, Mid Channel	51
Plot 78. 99% Occupied Bandwidth, HT20, Port 2, High Channel.....	51
Plot 79. 99% Occupied Bandwidth, HT30, Port 1, Low Channel	52
Plot 80. 99% Occupied Bandwidth, HT30, Port 1, Mid Channel	52
Plot 81. 99% Occupied Bandwidth, HT30, Port 1, High Channel.....	52
Plot 82. 99% Occupied Bandwidth, HT30, Port 2, Low Channel	53
Plot 83. 99% Occupied Bandwidth, HT30, Port 2, Mid Channel	53
Plot 84. 99% Occupied Bandwidth, HT30, Port 2, High Channel.....	53
Plot 85. 99% Occupied Bandwidth, HT40, Port 1, Low Channel	54
Plot 86. 99% Occupied Bandwidth, HT40, Port 1, Mid Channel	54
Plot 87. 99% Occupied Bandwidth, HT40, Port 1, High Channel.....	54
Plot 88. 99% Occupied Bandwidth, HT40, Port 2, Low Channel	55
Plot 89. 99% Occupied Bandwidth, HT40, Port 2, Mid Channel	55
Plot 90. 99% Occupied Bandwidth, HT40, Port 2, High Channel.....	55
Plot 91. Radiated Spurious Emissions, 802.11a 20 MHz, Low Channel, 30 MHz – 1 GHz	60
Plot 92. Radiated Spurious Emissions, Low Channel, 802.11a 20MHz, 1 GHz – 7 GHz, Average	60
Plot 93. Restricted Band, 802.11a 20 MHz, Low Channel.....	60
Plot 94. Radiated Spurious Emissions, Low Channel, 802.11a 20MHz, 1 GHz – 7 GHz, Peak.....	61
Plot 95 Radiated Spurious Emissions, Low Channel, 802.11a 20 MHz, 7 GHz – 18 GHz.....	61
Plot 96. Radiated Spurious Emissions, 802.11a 20 MHz, Mid Channel, 30 MHz – 1 GHz.....	62
Plot 97. Radiated Spurious Emissions, Mid Channel, 802.11a 20MHz, 1 GHz – 7 GHz, Average.....	62
Plot 98. Restricted Band, 802.11a 20 MHz, Mid Channel	62
Plot 99. Radiated Spurious Emissions, Mid Channel, 802.11a 20MHz, 1 GHz – 7 GHz, Peak.....	63
Plot 100. Radiated Spurious Emissions, Mid Channel, 802.11a 20 MHz, 7 GHz – 18 GHz	63
Plot 101. Radiated Spurious Emissions, 802.11a 20 MHz, High Channel, 30 MHz – 1 GHz	64
Plot 102. Radiated Spurious Emissions, High Channel, 802.11a 20MHz, 1 GHz – 7 GHz, Average.....	64
Plot 103. Restricted Band, 802.11a 20 MHz, High Channel	64

Plot 104. Radiated Spurious Emissions, High Channel, 802.11a 20MHz, 1 GHz – 7 GHz, Peak	65
Plot 105. Radiated Spurious Emissions, High Channel, 802.11a 20 MHz, 7 GHz – 18 GHz	65
Plot 106. Radiated Spurious Emissions, 802.11a 40 MHz, Low Channel, 30 MHz – 1 GHz	66
Plot 107. Radiated Spurious Emissions, Low Channel, 802.11a 40MHz, 1 GHz – 7 GHz, Average	66
Plot 108. Restricted Band, 802.11a 40 MHz, Low Channel.....	66
Plot 109. Radiated Spurious Emissions, Low Channel, 802.11a 40MHz, 1 GHz – 7 GHz, Peak	67
Plot 110. Radiated Spurious Emissions, Low Channel, 802.11a 40 MHz, 7 GHz – 18 GHz.....	67
Plot 111. Radiated Spurious Emissions, 802.11a 40 MHz, Mid Channel, 30 MHz – 1 GHz.....	68
Plot 112. Radiated Spurious Emissions, Mid Channel, 802.11a 40MHz, 1 GHz – 7 GHz, Average	68
Plot 113. Restricted Band, 802.11a 40 MHz, Mid Channel	68
Plot 114. Radiated Spurious Emissions, Mid Channel, 802.11a 40MHz, 1 GHz – 7 GHz, Peak.....	69
Plot 115. Radiated Spurious Emissions, Mid Channel, 802.11a 40 MHz, 7 GHz – 18 GHz	69
Plot 116. Radiated Spurious Emissions, 802.11a 40 MHz, High Channel, 30 MHz – 1 GHz	70
Plot 117. Radiated Spurious Emissions, High Channel, 802.11a 40MHz, 1 GHz – 7 GHz, Average.....	70
Plot 118. Restricted Band, 802.11a 40 MHz, High Channel	70
Plot 119. Radiated Spurious Emissions, High Channel, 802.11a 40MHz, 1 GHz – 7 GHz, Peak	71
Plot 120. Radiated Spurious Emissions, High Channel, 802.11a 40 MHz, 7 GHz – 18 GHz	71
Plot 121. Radiated Spurious Emissions, HT5, Low Channel, 30 MHz – 1 GHz.....	72
Plot 122. Radiated Spurious Emissions, HT5, Low Channel, 1 GHz – 7 GHz, Average.....	72
Plot 123. Restricted Band, HT5, Low Channel	73
Plot 124. Radiated Spurious Emissions, HT5, Low Channel, 1 GHz – 7 GHz, Peak	73
Plot 125. Radiated Spurious Emissions, HT5, Low Channel, 7 GHz – 18 GHz, Average.....	73
Plot 126. Radiated Spurious Emissions, HT5, Low Channel, 7 GHz – 18 GHz, Peak.....	74
Plot 127. Radiated Spurious Emissions, HT5, Mid Channel, 30 MHz – 1 GHz	75
Plot 128. Radiated Spurious Emissions, HT5, Mid Channel, 1 GHz – 7 GHz, Average	75
Plot 129. Restricted Band, HT5, Mid Channel.....	76
Plot 130. Radiated Spurious Emissions, HT5, Mid Channel, 1 GHz – 7 GHz, Peak	76
Plot 131. Radiated Spurious Emissions, HT5, Mid Channel, 7 GHz – 18 GHz, Average	76
Plot 132. Radiated Spurious Emissions, HT5, Mid Channel, 7 GHz – 18 GHz, Peak	77
Plot 133. Radiated Spurious Emissions, HT5, High Channel, 30 MHz – 1 GHz.....	78
Plot 134. Radiated Spurious Emissions, HT5, High Channel, 1 GHz – 7 GHz, Average	78
Plot 135. Restricted Band, HT5, High Channel.....	79
Plot 136. Radiated Spurious Emissions, HT5, High Channel, 1 GHz – 7 GHz, Peak.....	79
Plot 137. Radiated Spurious Emissions, HT5, High Channel, 7 GHz – 18 GHz, Average	79
Plot 138. Radiated Spurious Emissions, HT5, High Channel, 7 GHz – 18 GHz, Peak.....	80
Plot 139. Radiated Spurious Emissions, HT8, Low Channel, 30 MHz – 1 GHz.....	81
Plot 140. Radiated Spurious Emissions, HT8, Low Channel, 1 GHz – 7 GHz, Average.....	81
Plot 141. Restricted Band, HT8, Low Channel	82
Plot 142. Radiated Spurious Emissions, HT8, Low Channel, 1 GHz – 7 GHz, Peak	82
Plot 143. Radiated Spurious Emissions, HT8, Low Channel, 7 GHz – 18 GHz, Average.....	82
Plot 144. Radiated Spurious Emissions, HT8, Low Channel, 7 GHz – 18 GHz, Peak.....	83
Plot 145. Radiated Spurious Emissions, HT8, Mid Channel, 30 MHz – 1 GHz	84
Plot 146. Radiated Spurious Emissions, HT8, Mid Channel, 1 GHz – 7 GHz, Average	84
Plot 147. Restricted Band, HT8, Mid Channel.....	85
Plot 148. Radiated Spurious Emissions, HT8, Mid Channel, 1 GHz – 7 GHz, Peak	85
Plot 149. Radiated Spurious Emissions, HT8, Mid Channel, 7 GHz – 18 GHz, Average	85
Plot 150. Radiated Spurious Emissions, HT8, Mid Channel, 7 GHz – 18 GHz, Peak	86
Plot 151. Radiated Spurious Emissions, HT8, High Channel, 30 MHz – 1 GHz.....	87
Plot 152. Radiated Spurious Emissions, HT8, High Channel, 1 GHz – 7 GHz, Average	87
Plot 153. Restricted Band, HT8, High Channel.....	88
Plot 154. Radiated Spurious Emissions, HT8, High Channel, 1 GHz – 7 GHz, Peak.....	88
Plot 155. Radiated Spurious Emissions, HT8, High Channel, 7 GHz – 18 GHz, Average	88
Plot 156. Radiated Spurious Emissions, HT8, High Channel, 7 GHz – 18 GHz, Peak.....	89

Plot 157. Radiated Spurious Emissions, HT10, Low Channel, 30 MHz – 1 GHz.....	90
Plot 158. Radiated Spurious Emissions, HT10, Low Channel, 1 GHz – 7 GHz, Average.....	90
Plot 159. Restricted Band, HT10, Low Channel.....	91
Plot 160. Radiated Spurious Emissions, HT10, Low Channel, 1 GHz – 7 GHz, Peak.....	91
Plot 161. Radiated Spurious Emissions, HT10, Low Channel, 7 GHz – 18 GHz, Average.....	91
Plot 162. Radiated Spurious Emissions, HT10, Low Channel, 7 GHz – 18 GHz, Peak.....	92
Plot 163. Radiated Spurious Emissions, HT10, Mid Channel, 30 MHz – 1 GHz.....	93
Plot 164. Radiated Spurious Emissions, HT10, Mid Channel, 1 GHz – 7 GHz, Average.....	93
Plot 165. Restricted Band, HT10, Mid Channel.....	94
Plot 166. Radiated Spurious Emissions, HT10, Mid Channel, 1 GHz – 7 GHz, Peak.....	94
Plot 167. Radiated Spurious Emissions, HT10, Mid Channel, 7 GHz – 18 GHz, Average.....	94
Plot 168. Radiated Spurious Emissions, HT10, Mid Channel, 7 GHz – 18 GHz, Peak.....	95
Plot 169. Radiated Spurious Emissions, HT10, High Channel, 30 MHz – 1 GHz.....	96
Plot 170. Radiated Spurious Emissions, HT10, High Channel, 1 GHz – 7 GHz, Average.....	96
Plot 171. Restricted Band, HT10, High Channel.....	97
Plot 172. Radiated Spurious Emissions, HT10, High Channel, 1 GHz – 7 GHz, Peak.....	97
Plot 173. Radiated Spurious Emissions, HT10, High Channel, 7 GHz – 18 GHz, Average.....	97
Plot 174. Radiated Spurious Emissions, HT10, High Channel, 7 GHz – 18 GHz, Peak.....	98
Plot 175. Radiated Spurious Emissions, HT20, Low Channel, 30 MHz – 1 GHz.....	99
Plot 176. Radiated Spurious Emissions, HT20, Low Channel, 1 GHz – 7 GHz, Average.....	99
Plot 177. Restricted Band, HT20, Low Channel.....	100
Plot 178. Radiated Spurious Emissions, HT20, Low Channel, 1 GHz – 7 GHz, Peak.....	100
Plot 179. Radiated Spurious Emissions, HT20, Low Channel, 7 GHz – 18 GHz, Average.....	100
Plot 180. Radiated Spurious Emissions, HT20, Low Channel, 7 GHz – 18 GHz, Peak.....	101
Plot 181. Radiated Spurious Emissions, HT20, Mid Channel, 30 MHz – 1 GHz.....	102
Plot 182. Radiated Spurious Emissions, HT20, Mid Channel, 1 GHz – 7 GHz, Average.....	102
Plot 183. Restricted Band, HT20, Mid Channel.....	103
Plot 184. Radiated Spurious Emissions, HT20, Mid Channel, 1 GHz – 7 GHz, Peak.....	103
Plot 185. Radiated Spurious Emissions, HT20, Mid Channel, 7 GHz – 18 GHz, Average.....	103
Plot 186. Radiated Spurious Emissions, HT20, Mid Channel, 7 GHz – 18 GHz, Peak.....	104
Plot 187. Radiated Spurious Emissions, HT20, High Channel, 30 MHz – 1 GHz.....	105
Plot 188. Radiated Spurious Emissions, HT20, High Channel, 1 GHz – 7 GHz, Average.....	105
Plot 189. Restricted Band, HT20, High Channel.....	106
Plot 190. Radiated Spurious Emissions, HT20, High Channel, 1 GHz – 7 GHz, Peak.....	106
Plot 191. Radiated Spurious Emissions, HT20, High Channel, 7 GHz – 18 GHz, Average.....	106
Plot 192. Radiated Spurious Emissions, HT20, High Channel, 7 GHz – 18 GHz, Peak.....	107
Plot 193. Radiated Spurious Emissions, HT30, Low Channel, 30 MHz – 1 GHz.....	108
Plot 194. Radiated Spurious Emissions, HT30, Low Channel, 1 GHz – 7 GHz, Average.....	108
Plot 195. Restricted Band, HT30, Low Channel.....	109
Plot 196. Radiated Spurious Emissions, HT30, Low Channel, 1 GHz – 7 GHz, Peak.....	109
Plot 197. Radiated Spurious Emissions, HT30, Low Channel, 7 GHz – 18 GHz, Average.....	109
Plot 198. Radiated Spurious Emissions, HT30, Low Channel, 7 GHz – 18 GHz, Peak.....	110
Plot 199. Radiated Spurious Emissions, HT30, Mid Channel, 30 MHz – 1 GHz.....	111
Plot 200. Radiated Spurious Emissions, HT30, Mid Channel, 1 GHz – 7 GHz, Average.....	111
Plot 201. Restricted Band, HT30, Mid Channel.....	112
Plot 202. Radiated Spurious Emissions, HT30, Mid Channel, 1 GHz – 7 GHz, Peak.....	112
Plot 203. Radiated Spurious Emissions, HT30, Mid Channel, 7 GHz – 18 GHz, Average.....	112
Plot 204. Radiated Spurious Emissions, HT30, Mid Channel, 7 GHz – 18 GHz, Peak.....	113
Plot 205. Radiated Spurious Emissions, HT30, High Channel, 30 MHz – 1 GHz.....	114
Plot 206. Radiated Spurious Emissions, HT30, High Channel, 1 GHz – 7 GHz, Average.....	114
Plot 207. Restricted Band, HT30, High Channel.....	115
Plot 208. Radiated Spurious Emissions, HT30, High Channel, 1 GHz – 7 GHz, Peak.....	115
Plot 209. Radiated Spurious Emissions, HT30, High Channel, 7 GHz – 18 GHz, Peak.....	115

Plot 210. Radiated Spurious Emissions, HT30, High Channel, 7 GHz – 18 GHz, Average	116
Plot 211. Radiated Spurious Emissions, HT40, Low Channel, 30 MHz – 1 GHz.....	117
Plot 212. Radiated Spurious Emissions, HT40, Low Channel, 1 GHz – 7 GHz, Average	117
Plot 213. Restricted Band, HT40, Low Channel	118
Plot 214. Radiated Spurious Emissions, HT40, Low Channel, 1 GHz – 7 GHz, Peak	118
Plot 215. Radiated Spurious Emissions, HT40, Low Channel, 7 GHz – 18 GHz, Average	118
Plot 216. Radiated Spurious Emissions, HT40, Low Channel, 7 GHz – 18 GHz, Peak.....	119
Plot 217. Radiated Spurious Emissions, HT40, Mid Channel, 30 MHz – 1 GHz	120
Plot 218. Radiated Spurious Emissions, HT40, Mid Channel, 1 GHz – 7 GHz, Average	120
Plot 219. Restricted Band, HT40, Mid Channel	121
Plot 220. Radiated Spurious Emissions, HT40, Mid Channel, 1 GHz – 7 GHz, Peak	121
Plot 221. Radiated Spurious Emissions, HT40, Mid Channel, 7 GHz – 18 GHz, Average	121
Plot 222. Radiated Spurious Emissions, HT40, Mid Channel, 7 GHz – 18 GHz, Peak	122
Plot 223. Radiated Spurious Emissions, HT40, High Channel, 30 MHz – 1 GHz.....	123
Plot 224. Radiated Spurious Emissions, HT40, High Channel, 1 GHz – 7 GHz, Average	123
Plot 225. Restricted Band, HT40, High Channel.....	124
Plot 226. Radiated Spurious Emissions, HT40, High Channel, 1 GHz – 7 GHz, Peak.....	124
Plot 227. Radiated Spurious Emissions, HT40, High Channel, 7 GHz – 18 GHz, Average	124
Plot 228. Radiated Spurious Emissions, HT40, High Channel, 7 GHz – 18 GHz, Peak.....	125
Plot 229. Restricted Band, 802.11a 20 MHz, Low Channel.....	126
Plot 230. Restricted Band, 802.11a 20 MHz, Mid Channel	126
Plot 231. Restricted Band, 802.11a 20 MHz, High Channel	126
Plot 232. Restricted Band, 802.11a 40 MHz, Low Channel.....	127
Plot 233. Restricted Band, 802.11a 40 MHz, Mid Channel	127
Plot 234. Restricted Band, 802.11a 40 MHz, High Channel	127
Plot 235. Restricted Band, HT5, Low Channel	128
Plot 236. Restricted Band, HT5, Mid Channel.....	128
Plot 237. Restricted Band, HT5, High Channel.....	128
Plot 238. Restricted Band, HT8, Low Channel	129
Plot 239. Restricted Band, HT8, Mid Channel	129
Plot 240. Restricted Band, HT8, High Channel.....	129
Plot 241. Restricted Band, HT10, Low Channel	130
Plot 242. Restricted Band, HT10, Mid Channel	130
Plot 243. Restricted Band, HT10, High Channel.....	130
Plot 244. Restricted Band, HT20, Low Channel	131
Plot 245. Restricted Band, HT20, Mid Channel	131
Plot 246. Restricted Band, HT20, High Channel.....	131
Plot 247. Restricted Band, HT30, Low Channel	132
Plot 248. Restricted Band, HT30, Mid Channel	132
Plot 249. Restricted Band, HT30, High Channel.....	132
Plot 250. Restricted Band, HT40, Low Channel	133
Plot 251. Restricted Band, HT40, Mid Channel	133
Plot 252. Restricted Band, HT40, High Channel.....	133
Plot 253. Conducted Spurious, Low Channel, 802.11a 20 MHz, 30 MHz - 1 GHz.....	137
Plot 254. Conducted Spurious, Low Channel, 802.11a 20 MHz, 1 GHz - 40 GHz.....	137
Plot 255. Conducted Spurious, Mid Channel, 802.11a 20 MHz, 30 MHz - 1 GHz.....	137
Plot 256. Conducted Spurious, Mid Channel, 802.11a 20 MHz, 1 GHz - 40 GHz	138
Plot 257. Conducted Spurious, High Channel, 802.11a 20 MHz, 30 MHz - 1 GHz	138
Plot 258. Conducted Spurious, High Channel, 802.11a 20 MHz, 1 GHz - 40 GHz	138
Plot 259. Conducted Spurious, Low Channel, 802.11a 40 MHz, 30 MHz - 1 GHz.....	139
Plot 260. Conducted Spurious, Low Channel, 802.11a 40 MHz, 1 GHz - 40 GHz.....	139
Plot 261. Conducted Spurious, Mid Channel, 802.11a 40 MHz, 30 MHz - 1 GHz.....	139
Plot 262. Conducted Spurious, Mid Channel, 802.11a 40 MHz, 1 GHz - 40 GHz	140

Plot 263. Conducted Spurious, High Channel, 802.11a 40 MHz, 30 MHz - 1 GHz	140
Plot 264. Conducted Spurious, High Channel, 802.11a 40 MHz, 1 GHz - 40 GHz	140
Plot 265. Conducted Spurious, Low Channel, HT5, Port 1, 30 MHz – 1 GHz	141
Plot 266. Conducted Spurious, Low Channel, HT5, Port 1, 1 GHz – 40 GHz.....	141
Plot 267. Conducted Spurious, Mid Channel, HT5, Port 1, 30 MHz - 1 GHz.....	141
Plot 268. Conducted Spurious, Mid Channel, HT5, Port 1, 1 GHz - 40 GHz	142
Plot 269. Conducted Spurious, High Channel, HT5, Port 1, 30 MHz - 1 GHz	142
Plot 270. Conducted Spurious, High Channel, HT5, Port 1, 1 GHz - 40 GHz.....	142
Plot 271. Conducted Spurious, Low Channel, HT5, Port 2, 30 MHz - 1 GHz.....	143
Plot 272. Conducted Spurious, Low Channel, HT5, Port 2, 1 GHz – 40 GHz.....	143
Plot 273. Conducted Spurious, Mid Channel, HT5, Port 2, 30 MHz - 1 GHz.....	143
Plot 274. Conducted Spurious, Mid Channel, HT5, Port 2, 1 GHz - 40 GHz	144
Plot 275. Conducted Spurious, High Channel, HT5, Port 2, 30 MHz - 1 GHz	144
Plot 276. Conducted Spurious, High Channel, HT5, Port 2, 1 GHz - 40 GHz.....	144
Plot 277. Conducted Spurious, Low Channel, HT8, Port 1, 30 MHz - 1 GHz.....	145
Plot 278. Conducted Spurious, Low Channel, HT8, Port 1, 1 GHz - 40 GHz.....	145
Plot 279. Conducted Spurious, Mid Channel, HT8, Port 1, 30 MHz - 1 GHz.....	145
Plot 280. Conducted Spurious, Mid Channel, HT8, Port 1, 1 GHz - 40 GHz	146
Plot 281. Conducted Spurious, High Channel, HT8, Port 1, 30 MHz - 1 GHz	146
Plot 282. Conducted Spurious, High Channel, HT8, Port 1, 1 GHz - 40 GHz.....	146
Plot 283. Conducted Spurious, Low Channel, HT8, Port 2, 30 MHz - 1 GHz.....	147
Plot 284. Conducted Spurious, Low Channel, HT8, Port 2, 1 GHz - 40 GHz.....	147
Plot 285. Conducted Spurious, Mid Channel, HT8, Port 2, 30 MHz - 1 GHz.....	147
Plot 286. Conducted Spurious, Mid Channel, HT8, Port 2, 1 GHz - 40 GHz	148
Plot 287. Conducted Spurious, High Channel, HT8, Port 2, 30 MHz - 1 GHz	148
Plot 288. Conducted Spurious, High Channel, HT8, Port 2, 1 GHz - 40 GHz.....	148
Plot 289. Conducted Spurious, Low Channel, HT10, Port 1, 30 MHz - 1 GHz.....	149
Plot 290. Conducted Spurious, Low Channel, HT10, Port 1, 1 GHz - 40 GHz.....	149
Plot 291. Conducted Spurious, Mid Channel, HT10, Port 1, 30 MHz - 1 GHz.....	149
Plot 292. Conducted Spurious, Mid Channel, HT10, Port 1, 1 GHz - 40 GHz	150
Plot 293. Conducted Spurious, High Channel, HT10, Port 1, 30 MHz - 1 GHz	150
Plot 294. Conducted Spurious, High Channel, HT10, Port 1, 1 GHz - 40 GHz.....	150
Plot 295. Conducted Spurious, Low Channel, HT10, Port 2, 30 MHz - 1 GHz.....	151
Plot 296. Conducted Spurious, Low Channel, HT10, Port 2, 1 GHz - 40 GHz.....	151
Plot 297. Conducted Spurious, Mid Channel, HT10, Port 2, 30 MHz - 1 GHz.....	151
Plot 298. Conducted Spurious, Mid Channel, HT10, Port 2, 1 GHz - 40 GHz	152
Plot 299. Conducted Spurious, High Channel, HT10, Port 2, 30 MHz - 1 GHz	152
Plot 300. Conducted Spurious, High Channel, HT10, Port 2, 1 GHz - 40 GHz.....	152
Plot 301. Conducted Spurious, Low Channel, HT20, Port 1, 30 MHz - 1 GHz.....	153
Plot 302. Conducted Spurious, Low Channel, HT20, Port 1, 1 GHz - 40 GHz.....	153
Plot 303. Conducted Spurious, Mid Channel, HT20, Port 1, 30 MHz - 1 GHz.....	153
Plot 304. Conducted Spurious, Mid Channel, HT20, Port 1, 1 GHz - 40 GHz	154
Plot 305. Conducted Spurious, High Channel, HT20, Port 1, 30 MHz - 1 GHz	154
Plot 306. Conducted Spurious, High Channel, HT20, Port 1, 1 GHz - 40 GHz.....	154
Plot 307. Conducted Spurious, Low Channel, HT20, Port 2, 30 MHz - 1 GHz.....	155
Plot 308. Conducted Spurious, Low Channel, HT20, Port 2, 1 GHz - 40 GHz.....	155
Plot 309. Conducted Spurious, Mid Channel, HT20, Port 2, 30 MHz - 1 GHz.....	155
Plot 310. Conducted Spurious, Mid Channel, HT20, Port 2, 1 GHz - 40 GHz	156
Plot 311. Conducted Spurious, High Channel, HT20, Port 2, 30 MHz - 1 GHz	156
Plot 312. Conducted Spurious, High Channel, HT20, Port 2, 1 GHz - 40 GHz.....	156
Plot 313. Conducted Spurious, Low Channel, HT30, Port 1, 30 MHz - 1 GHz.....	157
Plot 314. Conducted Spurious, Low Channel, HT30, Port 1, 1 GHz - 40 GHz.....	157
Plot 315. Conducted Spurious, Mid Channel, HT30, Port 1, 30 MHz - 1 GHz.....	157

Plot 316. Conducted Spurious, Mid Channel, HT30, Port 1, 1 GHz - 40 GHz	158
Plot 317. Conducted Spurious, High Channel, HT30, Port 1, 30 MHz - 1 GHz	158
Plot 318. Conducted Spurious, High Channel, HT30, Port 1, 1 GHz - 40 GHz	158
Plot 319. Conducted Spurious, Low Channel, HT30, Port 2, 30 MHz - 1 GHz	159
Plot 320. Conducted Spurious, Low Channel, HT30, Port 2, 1 GHz - 40 GHz	159
Plot 321. Conducted Spurious, Mid Channel, HT30, Port 2, 30 MHz - 1 GHz	159
Plot 322. Conducted Spurious, Mid Channel, HT30, Port 2, 1 GHz - 40 GHz	160
Plot 323. Conducted Spurious, High Channel, HT30, Port 2, 30 MHz - 1 GHz	160
Plot 324. Conducted Spurious, High Channel, HT30, Port 2, 1 GHz - 40 GHz	160
Plot 325. Conducted Spurious, Low Channel, HT40, Port 1, 30 MHz - 1 GHz	161
Plot 326. Conducted Spurious, Low Channel, HT40, Port 1, 1 GHz - 40 GHz	161
Plot 327. Conducted Spurious, Mid Channel, HT40, Port 1, 30 MHz - 1 GHz	161
Plot 328. Conducted Spurious, Mid Channel, HT40, Port 1, 1 GHz - 40 GHz	162
Plot 329. Conducted Spurious, High Channel, HT40, Port 1, 30 MHz - 1 GHz	162
Plot 330. Conducted Spurious, High Channel, HT40, Port 1, 1 GHz - 40 GHz	162
Plot 331. Conducted Spurious, Low Channel, HT40, Port 2, 30 MHz - 1 GHz	163
Plot 332. Conducted Spurious, Low Channel, HT40, Port 2, 1 GHz - 40 GHz	163
Plot 333. Conducted Spurious, Mid Channel, HT40, Port 2, 30 MHz - 1 GHz	163
Plot 334. Conducted Spurious, Mid Channel, HT40, Port 2, 1 GHz - 40 GHz	164
Plot 335. Conducted Spurious, High Channel, HT40, Port 2, 30 MHz - 1 GHz	164
Plot 336. Conducted Spurious, High Channel, HT40, Port 2, 1 GHz - 40 GHz	164
Plot 337. Conducted Band Edge, 802.11a 20 MHz, Low Channel	165
Plot 338. Conducted Band Edge, 802.11a 20 MHz, High Channel	165
Plot 339. Conducted Band Edge, 802.11a 40 MHz, Low Channel	166
Plot 340. Conducted Band Edge, 802.11a 40 MHz, High Channel	166
Plot 341. Conducted Band Edge, HT5, Low Channel, Port 1	167
Plot 342. Conducted Band Edge, HT5, High Channel, Port 1	167
Plot 343. Conducted Band Edge, HT5, Low Channel, Port 2	168
Plot 344. Conducted Band Edge, HT5, High Channel, Port 2	168
Plot 345. Conducted Band Edge, HT8, Low Channel, Port 1	169
Plot 346. Conducted Band Edge, HT8, High Channel, Port 1	169
Plot 347. Conducted Band Edge, HT8, Low Channel, Port 2	170
Plot 348. Conducted Band Edge, HT8, High Channel, Port 2	170
Plot 349. Conducted Band Edge, HT10, Low Channel, Port 1	171
Plot 350. Conducted Band Edge, HT10, High Channel, Port 1	171
Plot 351. Conducted Band Edge, HT10, Low Channel, Port 2	172
Plot 352. Conducted Band Edge, HT10, High Channel, Port 2	172
Plot 353. Conducted Band Edge, HT20, Low Channel, Port 1	173
Plot 354. Conducted Band Edge, HT20, High Channel, Port 1	173
Plot 355. Conducted Band Edge, HT20, Low Channel, Port 2	174
Plot 356. Conducted Band Edge, HT20, High Channel, Port 2	174
Plot 357. Conducted Band Edge, HT30, Low Channel, Port 1	175
Plot 358. Conducted Band Edge, HT30, High Channel, Port 1	175
Plot 359. Conducted Band Edge, HT30, Low Channel, Port 2	176
Plot 360. Conducted Band Edge, HT30, High Channel, Port 2	176
Plot 361. Conducted Band Edge, HT40, Low Channel, Port 1	177
Plot 362. Conducted Band Edge, HT40, High Channel, Port 1	177
Plot 363. Conducted Band Edge, HT40, Low Channel, Port 2	178
Plot 364. Conducted Band Edge, HT40, High Channel, Port 2	178
Plot 365. Peak Power Spectral Density, 802.11 20 MHz, Low Channel	182
Plot 366. Peak Power Spectral Density, 802.11a 20 MHz, Mid Channel	182
Plot 367. Peak Power Spectral Density, 802.11a 20 MHz, High Channel	182
Plot 368. Peak Power Spectral Density, 802.11 40 MHz, Low Channel	183

Plot 369. Peak Power Spectral Density, 802.11a 40 MHz, Mid Channel.....	183
Plot 370. Peak Power Spectral Density, 802.11a 40 MHz, High Channel	183
Plot 371. Peak Power Spectral Density, HT5, Port 1, Low Channel.....	184
Plot 372. Peak Power Spectral Density, HT5, Port 1, Mid Channel.....	184
Plot 373. Peak Power Spectral Density, HT5, Port 1, High Channel	184
Plot 374. Peak Power Spectral Density, HT5 Port 2, Low Channel	185
Plot 375. Peak Power Spectral Density, HT5, Port 2, Mid Channel.....	185
Plot 376. Peak Power Spectral Density, HT5, Port 2, High Channel	185
Plot 377. Peak Power Spectral Density, HT8, Port 1, Low Channel	186
Plot 378. Peak Power Spectral Density, HT8, Port 1, Mid Channel.....	186
Plot 379. Peak Power Spectral Density, HT8, Port 1, High Channel	186
Plot 380. Peak Power Spectral Density, HT8, Port 2, Low Channel	187
Plot 381. Peak Power Spectral Density, HT8, Port 2, Mid Channel.....	187
Plot 382. Peak Power Spectral Density, HT8, Port 2, High Channel	187
Plot 383. Peak Power Spectral Density, HT10, Port 1, Low Channel	188
Plot 384. Peak Power Spectral Density, HT10, Port 1, Mid Channel.....	188
Plot 385. Peak Power Spectral Density, HT10, Port 1, High Channel	188
Plot 386. Peak Power Spectral Density, HT10, Port 2, Low Channel	189
Plot 387. Peak Power Spectral Density, HT10, Port 2, Mid Channel.....	189
Plot 388. Peak Power Spectral Density, HT10, Port 2, High Channel	189
Plot 389. Peak Power Spectral Density, HT20, Port 1, Low Channel	190
Plot 390. Peak Power Spectral Density, HT20, Port 1, Mid Channel.....	190
Plot 391. Peak Power Spectral Density, HT20, Port 1, High Channel	190
Plot 392. Peak Power Spectral Density, HT20, Port 2, Low Channel	191
Plot 393. Peak Power Spectral Density, HT20, Port 2, Mid Channel.....	191
Plot 394. Peak Power Spectral Density, HT20, Port 2, High Channel	191
Plot 395. Peak Power Spectral Density, HT30, Port 1, Low Channel	192
Plot 396. Peak Power Spectral Density, HT30, Port 1, Mid Channel.....	192
Plot 397. Peak Power Spectral Density, HT30, Port 1, High Channel	192
Plot 398. Peak Power Spectral Density, HT30 Port 2, Low Channel	193
Plot 399. Peak Power Spectral Density, HT30, Port 2, Mid Channel.....	193
Plot 400. Peak Power Spectral Density, HT30, Port 2, High Channel	193
Plot 401. Peak Power Spectral Density, HT40, Port 1, Low Channel	194
Plot 402. Peak Power Spectral Density, HT40, Port 1, Mid Channel.....	194
Plot 403. Peak Power Spectral Density, HT40, Port 1, High Channel	194
Plot 404. Peak Power Spectral Density, HT40 Port 2, Low Channel	195
Plot 405. Peak Power Spectral Density, HT40, Port 2, Mid Channel.....	195
Plot 406. Peak Power Spectral Density, HT40, Port 2, High Channel	195
Plot 407. Receiver Spurious Emission, 30 MHz – 1 GHz, Port 1	198
Plot 408. Receiver Spurious Emission, 1 GHz – 18 GHz, Port 1	198
Plot 409. Receiver Spurious Emission, 30 MHz – 1 GHz, Port 2	198
Plot 410. Receiver Spurious Emission, 1 GHz – 18 GHz, Port 2.....	199

List of Figures

Figure 1. Block Diagram of Test Configuration.....	7
Figure 2. Block Diagram, Occupied Bandwidth Test Setup.....	25
Figure 3. Peak Power Output Test Setup.....	56
Figure 4. Block Diagram, Conducted Spurious Emissions Test Setup.....	136
Figure 5. Block Diagram, Peak Power Spectral Density Test Setup	179
Figure 6. Block Diagram, Conducted Receiver Spurious Emissions Test Setup	197

List of Photographs

Photograph 1. Ubiquiti Networks PowerBridgeM5	6
Photograph 2. Conducted Emissions, Test Setup	14
Photograph 3. Radiated Emission, Test Setup	18
Photograph 4. Conducted Emissions, 15.207(a), Test Setup	24
Photograph 5. Radiated Spurious Emissions, Test Setup	134
Photograph 6. Radiated Spurious Emissions, Test Setup, 30 MHz – 1 GHz	135
Photograph 7. Radiated Spurious Emissions, Test Setup, 1 GHz – 18 GHz	135

List of Terms and Abbreviations

AC	Alternating Current
ACF	Antenna Correction Factor
Cal	Calibration
<i>d</i>	Measurement Distance
dB	Decibels
dB μ A	Decibels above one microamp
dB μ V	Decibels above one microvolt
dB μ A/m	Decibels above one microamp per meter
dB μ V/m	Decibels above one microvolt per meter
DC	Direct Current
E	Electric Field
DSL	Digital Subscriber Line
ESD	Electrostatic Discharge
EUT	Equipment Under Test
<i>f</i>	Frequency
FCC	Federal Communications Commission
GRP	Ground Reference Plane
H	Magnetic Field
HCP	Horizontal Coupling Plane
Hz	Hertz
IEC	International Electrotechnical Commission
kHz	kilohertz
kPa	kilopascal
kV	kilovolt
LISN	Line Impedance Stabilization Network
MHz	Megahertz
μ H	microhenry
μ	microfarad
μ s	microseconds
NEBS	Network Equipment-Building System
PRF	Pulse Repetition Frequency
RF	Radio Frequency
RMS	Root-Mean-Square
TWT	Traveling Wave Tube
V/m	Volts per meter
VCP	Vertical Coupling Plane

I. Executive Summary

A. Purpose of Test

An EMC evaluation was performed to determine compliance of the Ubiquiti Networks PowerBridgeM5, with the requirements of Part 15, §15.247. All references are to the most current version of Title 47 of the Code of Federal Regulations in effect. In accordance with §2.1033, the following data is presented in support of the Certification of the PowerBridgeM5. Ubiquiti Networks should retain a copy of this document which should be kept on file for at least two years after the manufacturing of the PowerBridgeM5, has been **permanently** discontinued.

B. Executive Summary

The following tests were conducted on a sample of the equipment for the purpose of demonstrating compliance with Part 15, §15.247, in accordance with Ubiquiti Networks, purchase order number US100133/US100132. All tests were conducted using measurement procedure ANSI C63.4-2003.

FCC Reference 47 CFR Part 15.247:2005	IC Reference RSS-210 Issue 8: 2010	Description	Compliance
47 CFR Part 15.107 (a)	ICES-003 Issue 4 February 2004	Conducted Emission Limits for a Class A Digital Device	Compliant
47 CFR Part 15.109 (a)	ICES-003 Issue 4 February 2004	Radiated Emission Limits for a Class A Digital Device	Compliant
Title 47 of the CFR, Part 15 §15.203	N/A	Antenna Requirement	Compliant
Title 47 of the CFR, Part 15 §15.207(a)	RSS-210(7.2.2)	Conducted Emission Limits	Compliant
Title 47 of the CFR, Part 15 §15.247(a)(2)	RSS-Gen(4.6)	6dB Occupied Bandwidth	Compliant
		99% Occupied Bandwidth	Compliant
Title 47 of the CFR, Part 15 §15.247(b)	RSS-210(A8.4)	Peak Power Output	Compliant
Title 47 of the CFR, Part 15 §15.247(d); §15.209; §15.205	RSS-210(A8.5)	Radiated Spurious Emissions Requirements	Compliant
Title 47 of the CFR, Part 15 §15.247(d)	RSS-210(A8.5)	RF Conducted Spurious Emissions Requirements	Compliant
Title 47 of the CFR, Part 15 §15.247(d)	RSS-210(A8.5)	RF Conducted Band Edge	Compliant
Title 47 of the CFR, Part 15; §15.247(e)	RSS-210(A8.3)	Peak Power Spectral Density	Compliant
Title 47 of the CFR, Part 15 §15.247(i)	RSS-Gen(5.5)	Maximum Permissible Exposure (MPE)	Compliant
N/A	RSS-Gen(4.8)	Receiver Spurious Emissions	Compliant

Table 1. Executive Summary of EMC Part 15.247 Compliance Testing

II. Equipment Configuration

A. Overview

MET Laboratories, Inc. was contracted by Ubiquiti Networks to perform testing on the PowerBridgeM5, under Ubiquiti Networks's purchase order number US100133/US100132.

This document describes the test setups, test methods, required test equipment, and the test limit criteria used to perform compliance testing of the Ubiquiti Networks, PowerBridgeM5.

The results obtained relate only to the item(s) tested.

Model(s) Tested:	PowerBridgeM5	
Model(s) Covered:	PowerBridgeM5	
EUT Specifications:	Primary Power: 120 VAC, 60 Hz	
	FCC ID: SWX-M5P IC: 6545A-M5P	
	OATS:	2043C-1
	Type of Modulations:	OFDM
	Equipment Code:	DTS
	Peak RF Output Power:	802.11a 20 MHz – 24.01 dBm; 802.11a 40 MHz – 22.92 dBm; 802.11n HT5 – 24.35 dBm; 802.11n HT8 – 24.22 dBm; 802.11n HT10 – 25.12 dBm; 802.11n HT20 – 26.22 dBm; 802.11n HT30 – 25.97 dBm; 802.11n HT40 – 25.41 dBm
	Occupied Bandwidth (99%):	802.11a 20 MHz – 16.6228 MHz; 802.11a 40 MHz – 36.7310 MHz; 802.11n HT5 – 4.2037 MHz; 802.11n HT8 – 7.0016 MHz; 802.11n HT10 – 8.4694 MHz; 802.11n HT20 – 16.6020 MHz; 802.11n HT30 – 25.4231 MHz; 802.11n HT40 – 36.6606 MHz
	Antenna Gain:	25 dBi integral
	EUT Frequency Ranges:	5735 – 5840 MHz; 5747 – 5828 MHz; 5728 – 5847 MHz; 5730 – 5845 MHz; 5731 – 5844 MHz; 5740 – 5835 MHz;
Analysis:	The results obtained relate only to the item(s) tested.	
Environmental Test Conditions:	Temperature: 15-35° C	
	Relative Humidity: 30-60%	
	Barometric Pressure: 860-1060 mbar	
Evaluated by:	Lionel Gabrillo	
Report Date(s):	December 27, 2011	

Table 2. EUT Summary Table

B. References

CFR 47, Part 15, Subpart C	Federal Communication Commission, Code of Federal Regulations, Title 47, Part 15: General Rules and Regulations, Allocation, Assignment, and Use of Radio Frequencies
RSS-210, Issue 8, Dec. 2010	Low-power Licence-exempt Radiocommunications Devices (All Frequency Bands): Category I Equipment
CFR 47, Part 15, Subpart B	Electromagnetic Compatibility: Criteria for Radio Frequency Devices
ICES-003, Issue 4 February 2004	Electromagnetic Compatibility: Criteria for Radio Frequency Devices
ANSI C63.4:2003	Methods and Measurements of Radio-Noise Emissions from Low-Voltage Electrical And Electronic Equipment in the Range of 9 kHz to 40 GHz
ANSI/NCSL Z540-1-1994	Calibration Laboratories and Measuring and Test Equipment - General Requirements
ANSI/ISO/IEC 17025:2000	General Requirements for the Competence of Testing and Calibration Laboratories
ANSI C63.10-2009	American National Standard for Testing Unlicensed Wireless Devices

Table 3. References

C. Test Site

All testing was performed at MET Laboratories, Inc., 3162 Belick St., Santa Clara, CA 95054. All equipment used in making physical determinations is accurate and bears recent traceability to the National Institute of Standards and Technology.

Radiated Emissions measurements were performed in a 10 meter semi-anechoic chamber (equivalent to an Open Area Test Site). In accordance with §2.948(a)(3), a complete site description is contained at MET Laboratories.

D. Description of Test Sample

The Ubiquiti Networks PowerBridgeM5, Equipment Under Test (EUT), is a Long-Range Carrier Class 5GHz MIMO Bridging Solution.



Photograph 1. Ubiquiti Networks PowerBridgeM5

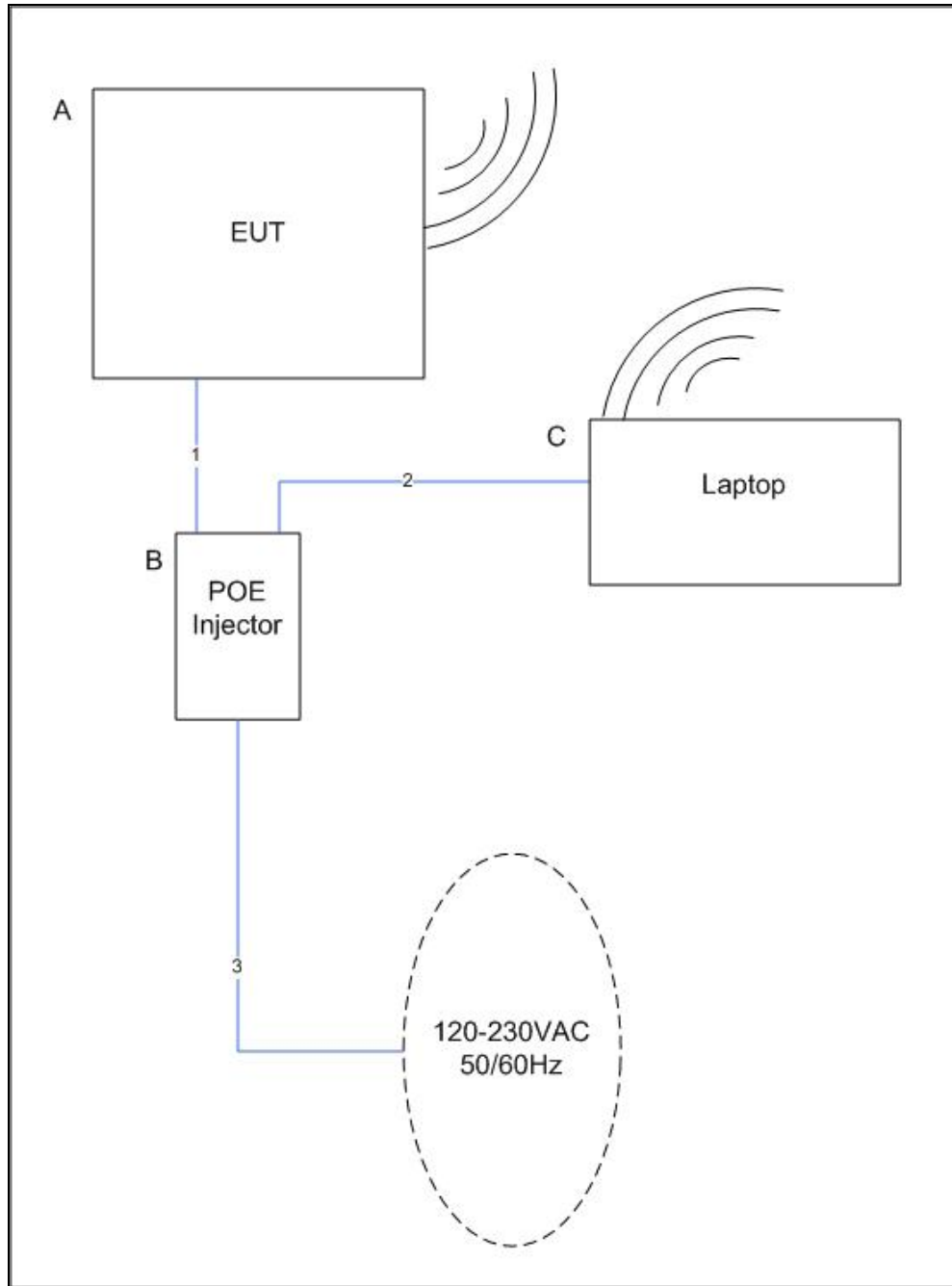

Figure 1. Block Diagram of Test Configuration

E. Equipment Configuration

The EUT was set up as outlined in Figure 1, Block Diagram of Test Setup. All cards, racks, etc., incorporated as part of the EUT is included in the following list.

Ref. ID	Name / Description	Model Number	Serial Number
A	PowerBridgeM5	M5P	00156D3A893B
A	PowerBridgeM5	M5P	00156D9A5045
A	PowerBridgeM5	M5P	00156D3A8992
B	POE Adaptor	UBI-POE-24-1	1009-0000326

Table 4. Equipment Configuration

F. Support Equipment

Support equipment necessary for the operation and testing of the EUT is included in the following list.

Ref. ID	Name / Description	Manufacturer	Model Number	Serial Number
C	Laptop	Dell	Vostro 1510	4953929473

Table 5. Support Equipment

G. Ports and Cabling Information

Ref. ID	Port Name on EUT	Cable Description	Qty.	Length (m)	Shielded (Y/N)	Termination Point
1	PowerBridgeM5 - Main	Ethernet	1	10	Y	PSU – POE port
1	PSU - POE	Ethernet	1	10	Y	NanoM5 - Main
2	PSU - LAN	Ethernet	1	10	Y	Laptop
3	AC port	AC Cable	1	0.5	Y	100-240VAC Source

Table 6. Ports and Cabling Information

H. Mode of Operation

Transmit 1-24Mbps and 36-54Mbps at 5GHz.

I. Method of Monitoring EUT Operation

IP connectivity is maintained with the EUT. If IP connectivity is lost, EUT connectivity shall be re-established upon power up or re-boot.

J. Modifications

- a) **Modifications to EUT**
No modifications were made to the EUT.
- b) **Modifications to Test Standard**
No modifications were made to the test standard.

K. Disposition of EUT

The test sample including all support equipment submitted to the Electro-Magnetic Compatibility Lab for testing was returned to Ubiquiti Networks upon completion of testing.

III. Electromagnetic Compatibility Criteria for Unintentional Radiators

Electromagnetic Compatibility Criteria

§ 15.107 Conducted Emissions Limits

Test Requirement(s): **15.107 (a)** Except for Class A digital devices, for equipment that is designed to be connected to the public utility (AC) power line, the radio frequency voltage that is conducted back onto the AC power line on any frequency or frequencies within the band 150 kHz to 30 MHz shall not exceed the limits in Table 7. Compliance with this provision shall be based on the measurement of the radio frequency voltage between each power line and ground at the power terminals.

15.107 (b) For a Class A digital device that is designed to be connected to the public utility (AC) power line, the radio frequency voltage that is conducted back onto the AC power line on any frequency or frequencies within the band 150 kHz to 30 MHz shall not exceed the limits in Table 7. Compliance with this provision shall be based on the measurement of the radio frequency voltage between each power line and ground at the power terminals. The lower limit applies at the band edges.

15.207(a), Except as shown in paragraphs (b) and (c) of this section*, charging, AC adapters or battery eliminators the radio frequency voltage that is conducted back onto the AC power line on any frequency or frequencies, within the band 150 kHz to 30 MHz, shall not exceed the limits in the Table 7, as measured using a 50 μ H/50 ohms line impedance stabilization network (LISN). Compliance with the provisions of this paragraph shall be based on the measurement of the radio frequency voltage between each power line and ground at the power terminal. The lower limit applies at the boundary between the frequencies ranges.

Frequency range (MHz)	Class A Conducted Limits (dB μ V)		*Class B Conducted Limits (dB μ V)	
	Quasi-Peak	Average	Quasi-Peak	Average
* 0.15- 0.45	79	66	66 - 56	56 - 46
0.45 - 0.5	79	66	56	46
0.5 - 30	73	60	60	50

Note 1 — The lower limit shall apply at the transition frequencies.
 Note 2 — The limit decreases linearly with the logarithm if the frequency in the range 0.15 MHz to 0.5 MHz.
 * -- Limits per Subsection 15.207(a).

Table 7. Conducted Limits for Radio Frequency Devices calculated from FCC Part 15 Subsections 15.107(a) (b) and 15.207(a)

Test Results: The EUT was compliant with the Class A requirement(s) of this section. Measured emissions were below applicable limits.

Test Engineer(s): Allan Gazza

Test Date(s): 02/24/11

Conducted Emissions - Voltage, AC Power, Phase Line (120 VAC, 60 Hz)

Line	Freq. (MHz)	QP Amplitude	QP Limit	Delta	Pass	Average Amplitude	Average Limit	Delta	Pass
Line 1	.150	55.4	79	-23.6	Pass	34.6	66	-31.4	Pass
Line 1	.200	48.9	79	-30.1	Pass	31.2	66	-34.8	Pass
Line 1	28.7	18.7	73	-54.3	Pass	13.6	60	-46.4	Pass

Table 8. Conducted Emissions - Voltage, AC Power, Phase Line (120 VAC, 60 Hz)

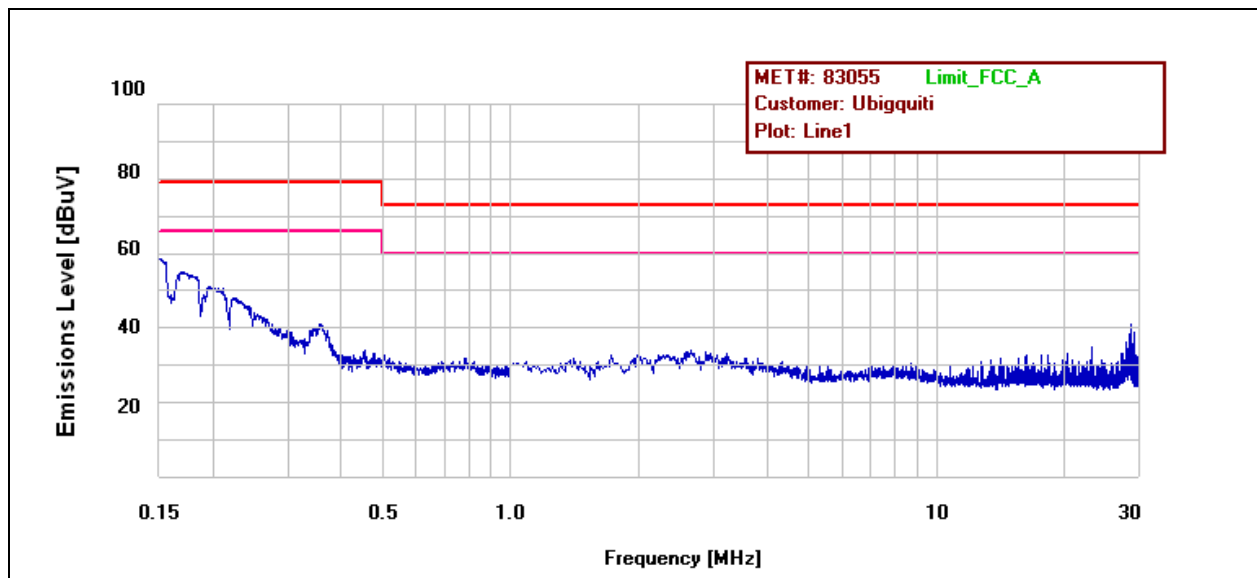

Plot 1. Conducted Emission, Phase Line Plot

Conducted Emissions - Voltage, AC Power, Neutral Line (120 VAC, 60 Hz)

Line	Freq. (MHz)	QP Amplitude	QP Limit	Delta	Pass	Average Amplitude	Average Limit	Delta	Pass
Neutral	.150	54.6	79	-24.4	Pass	25.2	66	-40.8	Pass
Neutral	.208	47.4	79	-31.6	Pass	27.3	66	-38.7	Pass
Neutral	28.7	19.2	73	-53.8	Pass	13.6	60	-46.4	Pass

Table 9. Conducted Emissions - Voltage, AC Power, Neutral Line (120 VAC, 60 Hz)

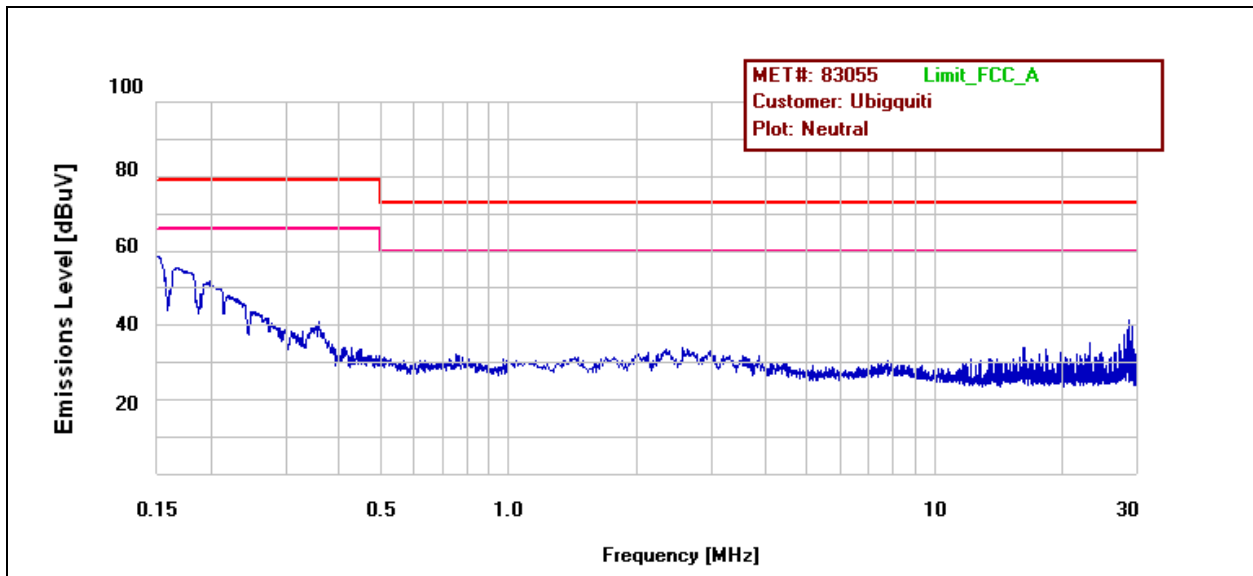

Plot 2. Conducted Emission, Neutral Line Plot

Conducted Emission Limits Test Setup



Photograph 2. Conducted Emissions, Test Setup

Radiated Emission Limits

§ 15.109 Radiated Emissions Limits

Test Requirement(s): **15.109 (a)** Except for Class A digital devices, the field strength of radiated emissions from unintentional radiators at a distance of 3 meters shall not exceed the Class B limits expressed in Table 10.

15.109 (b) The field strength of radiated emissions from a Class A digital device, as determined at a distance of 10 meters, shall not exceed the Class A limits expressed in Table 10.

Frequency (MHz)	Field Strength (dB μ V/m)	
	§15.109 (b), Class A Limit (dB μ V) @ 10m	§15.109 (a), Class B Limit (dB μ V) @ 3m
30 - 88	39.00	40.00
88 - 216	43.50	43.50
216 - 960	46.40	46.00
Above 960	49.50	54.00

Table 10. Radiated Emissions Limits calculated from FCC Part 15, §15.109 (a) (b)

Test Procedures: The EUT was placed on a non-metallic table, 80 cm above the ground plane inside a semi-anechoic chamber. The method of testing and test conditions of ANSI C63.4 were used. An antenna was located 10m from the EUT on an adjustable mast. A pre-scan was first performed in order to find prominent radiated emissions. For final emissions measurements at each frequency of interest, the EUT was rotated and the antenna height was varied between 1 m and 4 m in order to maximize the emission. Measurements in both horizontal and vertical polarities were made and the data was recorded. Unless otherwise specified, measurements were made using a quasi-peak detector with a 120 kHz bandwidth.

Test Results: The EUT was compliant with the Class A requirement(s) of this section. Measured emissions were below applicable limits.

Test Engineer(s): Lionel Gabrillo

Test Date(s): 03/16/11

Radiated Emissions Limits Test Results, Class A

Frequency (MHz)	Antenna Polarity	EUT Azimuth (Degrees)	Antenna Height (cm)	Uncorrected Amplitude (dBuV)	ACF (dB/m)	Pre Amp Gain (dB)	CBL (dB)	DCF (dB)	Corrected Amplitude (dBuV)	Limit (dBuV)	Margin (dB)
143.26	V	303.3	120.4	53.75	10.748	40	1.934	0	26.432	43.5	-17.068
389.97	V	146.4	100.0	50.58	15.899	40	3.261	0	29.74	46.4	-16.66
389.97	H	231.0	242.3	54.2	14.9	40	3.261	0	32.361	46.4	-14.039
779.97	H	246.1	112.4	45.87	19.798	40	4.693	0	30.361	46.4	-16.039
779.97	V	177.3	170.6	46.48	20.099	40	4.693	0	31.272	46.4	-15.128
974.98	V	150.4	139.2	46.41	21.501	40	5.283	0	33.194	49.5	-16.306

Table 11. Radiated Emissions Limits, Test Results, 30 MHz – 1 GHz, FCC Limits

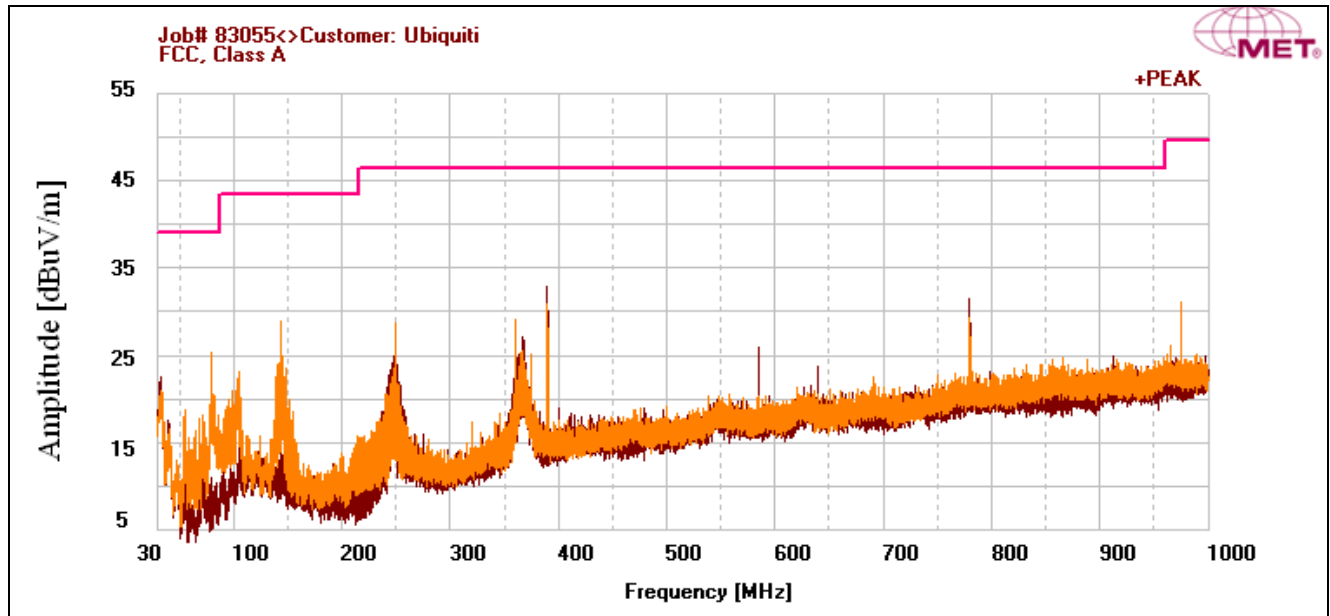

Plot 3. Radiated Emissions, 30 MHz - 1 GHz, FCC Limits

Radiated Emissions Limits Test Results, Class A

Frequency (MHz)	Antenna Polarity	EUT Azimuth (Degrees)	Antenna Height (cm)	Uncorrected Amplitude (dBuV)	ACF (dB/m)	Pre Amp Gain (dB)	CBL (dB)	DCF (dB)	Corrected Amplitude (dBuV)	Limit (dBuV)	Margin (dB)
143.26	V	303.3	120.4	53.75	10.748	40	1.934	0	26.432	40	-13.568
389.97	V	146.4	100.0	50.58	15.899	40	3.261	0	29.74	47	-17.26
389.97	H	231.0	242.3	54.2	14.9	40	3.261	0	32.361	47	-14.639
779.97	H	246.1	112.4	45.87	19.798	40	4.693	0	30.361	47	-16.639
779.97	V	177.3	170.6	46.48	20.099	40	4.693	0	31.272	47	-15.728
974.98	V	150.4	139.2	46.41	21.501	40	5.283	0	33.194	47	-13.806

Table 12. Radiated Emissions Limits, Test Results, ICES-003 Limits

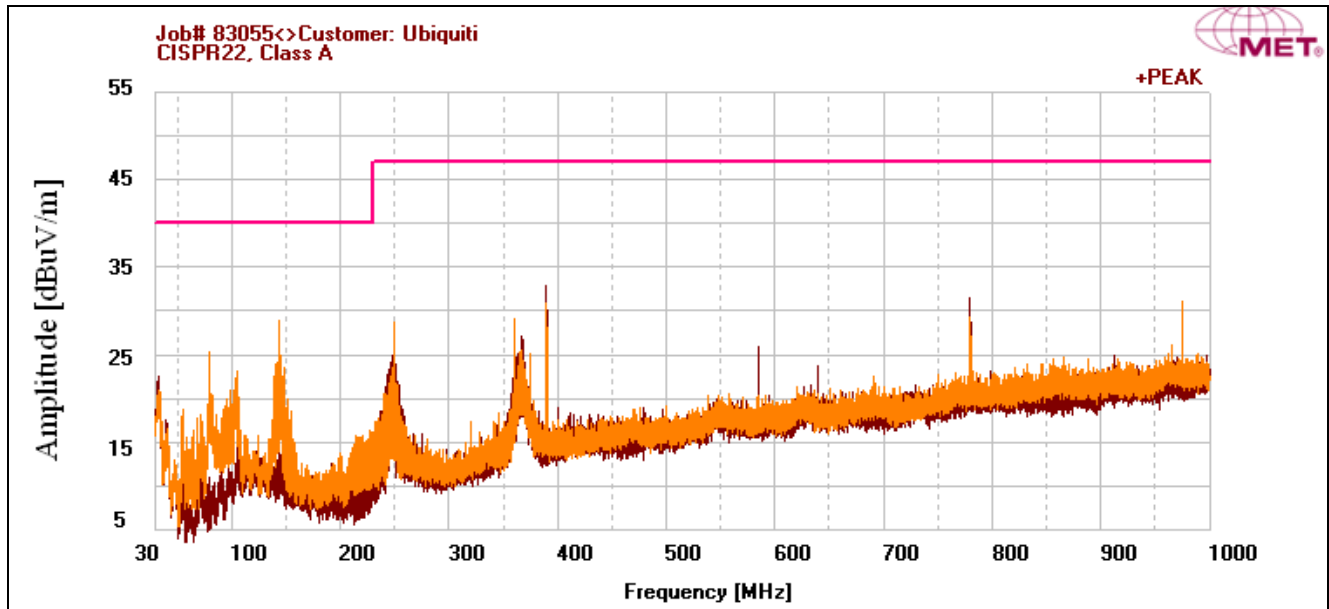

Plot 4. Radiated Emissions, ICES-003 Limits

Radiated Emission Limits Test Setup

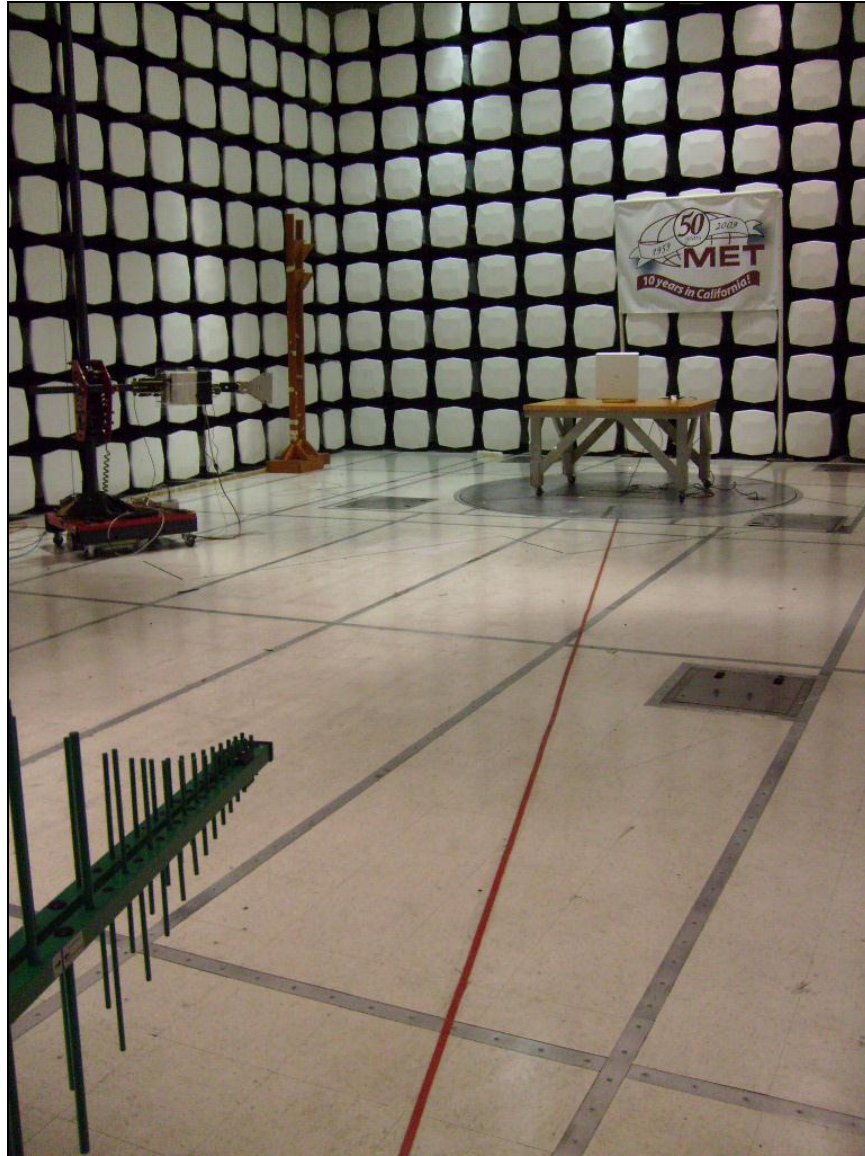

Photograph 3. Radiated Emission, Test Setup

IV. Electromagnetic Compatibility Criteria for Intentional Radiators

Electromagnetic Compatibility Criteria for Intentional Radiators

§ 15.203 Antenna Requirement

Test Requirement:

§ 15.203: An intentional radiator shall be designed to ensure that no antenna other than that furnished by the responsible party shall be used with the device. The use of a permanently attached antenna or of an antenna that uses a unique coupling to the intentional radiator shall be considered sufficient to comply with the provisions of this section. The manufacturer may design the unit so that a broken antenna can be replaced by the user, but the use of a standard antenna jack or electrical connector is prohibited.

The structure and application of the EUT were analyzed to determine compliance with Section 15.203 of the Rules. Section 15.203 states that the subject device must meet at least one of the following criteria:

- a.) Antenna must be permanently attached to the unit.
- b.) Antenna must use a unique type of connector to attach to the EUT.
- c.) Unit must be professionally installed. Installer shall be responsible for verifying that the correct antenna is employed with the unit.

Results:

The EUT as tested is compliant the criteria of §15.203. EUT has an integral antenna.

Test Engineer(s):

Lionel Gabrillo

Test Date(s):

03/18/11

Gain	Type	Model	Manufacturer
25dBi	Integral	N/A	Ubiquiti

Table 13. Antenna List

Electromagnetic Compatibility Criteria for Intentional Radiators

§ 15.207(a) Conducted Emissions Limits

Test Requirement(s): § 15.207 (a): For an intentional radiator that is designed to be connected to the public utility (AC) power line, the radio frequency voltage that is conducted back onto the AC power line on any frequency or frequencies, within the band 150 kHz to 30MHz, shall not exceed the limits in the following table, as measured using a 50 μ H/50 Ω line impedance stabilization network (LISN). Compliance with the provisions of this paragraph shall be based on the measurement of the radio frequency voltage between each power line and ground at the power terminal. The lower limit applies at the boundary between the frequency ranges.

Frequency range (MHz)	§ 15.207(a), Conducted Limit (dB μ V)	
	Quasi-Peak	Average
* 0.15- 0.45	66 - 56	56 - 46
0.45 - 0.5	56	46
0.5 - 30	60	50

Table 14. Conducted Limits for Intentional Radiators from FCC Part 15 § 15.207(a)

Test Procedure: The EUT was placed on a 0.8 m-high wooden table inside a screen room. The EUT was situated such that the back of the EUT was 0.4 m from one wall of the vertical ground plane, and the remaining sides of the EUT were no closer than 0.8 m from any other conductive surface. The EUT was powered from a 50 Ω /50 μ H Line Impedance Stabilization Network (LISN). The EMC receiver scanned the frequency range from 150 kHz to 30 MHz. Conducted Emissions measurements were made in accordance with *ANSI C63.4-2003 "Methods and Measurements of Radio-Noise Emissions from Low-Voltage Electrical and Electronic Equipment in the Range of 9kHz to 40 GHz"*. The measurements were performed over the frequency range of 0.15 MHz to 30 MHz using a 50 Ω /50 μ H LISN as the input transducer to an EMC/field intensity meter. For the purpose of this testing, the transmitter was turned on. Scans were performed with the transmitter on.

Test Results: The EUT was compliant with this requirement. Measured emissions were below applicable limits.

Test Engineer(s): Allan Gazza

Test Date(s): 02/24/11

15.207(a) Conducted Emissions Test Results

Line	Freq. (MHz)	QP Amplitude	QP Limit	Delta	Pass	Average Amplitude	Average Limit	Delta	Pass
Line1	.160	53.6	65.465	-11.865	Pass	30.8	55.465	-24.665	Pass
Line1	.202	48	63.535	-15.535	Pass	25.3	53.535	-28.235	Pass
Line1	28.7	20.1	60	-39.9	Pass	14.8	50	-35.2	Pass

Table 15. Conducted Emissions, 15.207(a), Phase Line, Test Results

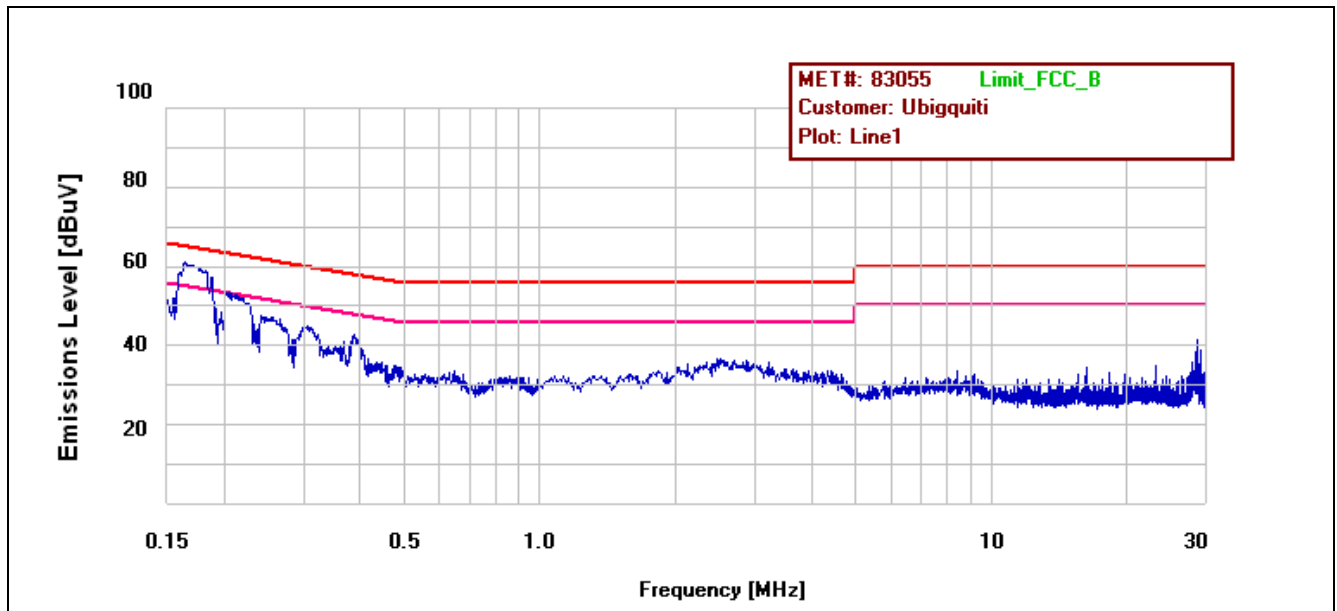

Plot 5. Conducted Emissions, 15.207(a), Phase Line

15.207(a) Conducted Emissions Test Results

Line	Freq. (MHz)	QP Amplitude	QP Limit	Delta	Pass	Average Amplitude	Average Limit	Delta	Pass
Neutral	.166	57.5	65.16	-7.66	Pass	31.6	55.16	-23.56	Pass
Neutral	.198	44.4	63.7	-19.3	Pass	23.8	53.7	-29.9	Pass
Neutral	.204	47.3	63.453	-16.153	Pass	26.3	53.453	-27.153	Pass
Neutral	28.5	20.8	60	-39.2	Pass	15	50	-35	Pass

Table 16. Conducted Emissions, 15.207(a), Neutral Line, Test Results

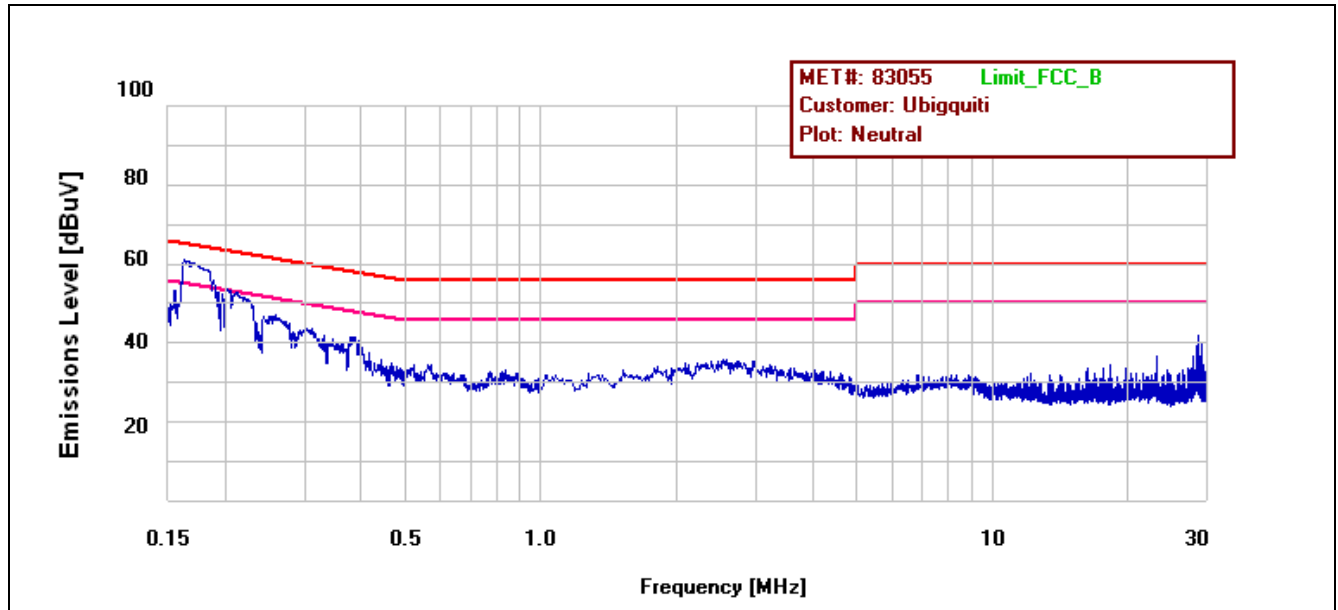

Plot 6. Conducted Emissions, 15.207(a), Neutral Line

15.207(a) Conducted Emissions Test Setup Photo



Photograph 4. Conducted Emissions, 15.207(a), Test Setup

Electromagnetic Compatibility Criteria for Intentional Radiators

§ 15.247(a)(2) 6 dB and 99% Bandwidth

Test Requirements: § 15.247(a)(2): Operation under the provisions of this section is limited to frequency hopping and digitally modulated intentional radiators that comply with the following provisions:

For systems using digital modulation techniques, the EUT may operate in the 902-928 MHz, 2400-2483.5 MHz and 5725-5850 MHz bands. The minimum 6dB bandwidth shall be at least 500 kHz.

Test Procedure: The transmitter was on and transmitting at the highest output power. The bandwidth of the fundamental frequency was measured with the spectrum analyzer using a RBW approximately 1% of the total emission bandwidth, VBW > RBW. The 6 dB Bandwidth was measured and recorded. The measurements were performed on the low, mid and high channels.

Test Results The EUT was compliant with § 15.247 (a)(2).

The 6 dB and 99% Bandwidth was determined from the plots on the following pages.

Test Engineer(s): Lionel Gabrillo

Test Date(s): 03/10/11

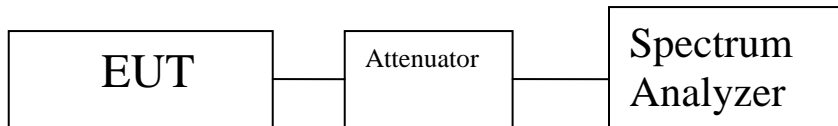

Figure 2. Block Diagram, Occupied Bandwidth Test Setup

Occupied Bandwidth Test Results

Occupied Bandwidth			
Mode	Carrier Channel	Frequency (MHz)	Measured 6 dB Bandwidth (MHz)
802.11a 20 MHz	Low	5735	16.539
	Mid	5787	16.564
	High	5840	16.536
802.11a 40 MHz	Low	5747	36.536
	Mid	5787	36.538
	High	5825	36.544
HT5 Port 1	Low	5728	4.147
	Mid	5787	4.141
	High	5847	4.142
HT5 Port 2	Low	5728	4.135
	Mid	5787	4.125
	High	5847	4.134
HT8 Port 1	Low	5730	6.620
	Mid	5787	6.379
	High	5845	6.416
HT8 Port 2	Low	5730	6.615
	Mid	5787	6.382
	High	5845	6.388
HT10 Port 1	Low	5731	8.260
	Mid	5787	8.242
	High	5844	8.244
HT10 Port 2	Low	5731	8.263
	Mid	5787	8.260
	High	5844	8.265
HT20 Port 1	Low	5735	16.566
	Mid	5787	16.585
	High	5840	16.574
HT20 Port 2	Low	5735	16.536
	Mid	5787	16.552
	High	5840	16.534
HT30 Port 1	Low	5740	24.790
	Mid	5787	24.811
	High	5835	24.839
HT30 Port 2	Low	5740	24.802
	Mid	5787	24.809
	High	5835	24.816
HT40 Port 1	Low	5747	36.548
	Mid	5787	36.564
	High	5828	36.561
HT40 Port 2	Low	5747	36.553
	Mid	5787	36.532
	High	5828	36.559

Table 17. 6 dB Occupied Bandwidth, Test Results

Occupied Bandwidth			
Mode	Carrier Channel	Frequency (MHz)	Measured 99% Bandwidth (MHz)
802.11a 20 MHz	Low	5735	16.5656
	Mid	5787	16.6224
	High	5840	16.6228
802.11a 40 MHz	Low	5747	36.5742
	Mid	5787	36.5095
	High	5828	36.7310
HT5 Port 1	Low	5728	4.2037
	Mid	5787	4.1684
	High	5847	4.1641
HT5 Port 2	Low	5728	4.2022
	Mid	5787	4.2008
	High	5847	4.1770
HT8 Port 1	Low	5730	6.8442
	Mid	5787	6.6805
	High	5845	6.6532
HT8 Port 2	Low	5730	7.0016
	Mid	5787	6.6324
	High	5845	6.6239
HT10 Port 1	Low	5731	8.4488
	Mid	5787	8.4396
	High	5844	8.4539
HT10 Port 2	Low	5731	8.4620
	Mid	5787	8.4694
	High	5844	8.4620
HT20 Port 1	Low	5735	16.5641
	Mid	5787	16.5595
	High	5840	16.4895
HT20 Port 2	Low	5735	16.6020
	Mid	5787	16.5705
	High	5840	16.5299
HT30 Port 1	Low	5740	25.3494
	Mid	5787	25.3115
	High	5835	25.3364
HT30 Port 2	Low	5740	25.4231
	Mid	5787	24.4039
	High	5835	25.3666
HT40 Port 1	Low	5747	36.5874
	Mid	5787	36.5795
	High	5828	36.6606
HT40 Port 2	Low	5747	36.6355
	Mid	5787	36.6188
	High	5828	36.5654

Table 18. 99% Occupied Bandwidth, Test Results

6 dB Occupied Bandwidth Test Results, 802.11a 20 MHz

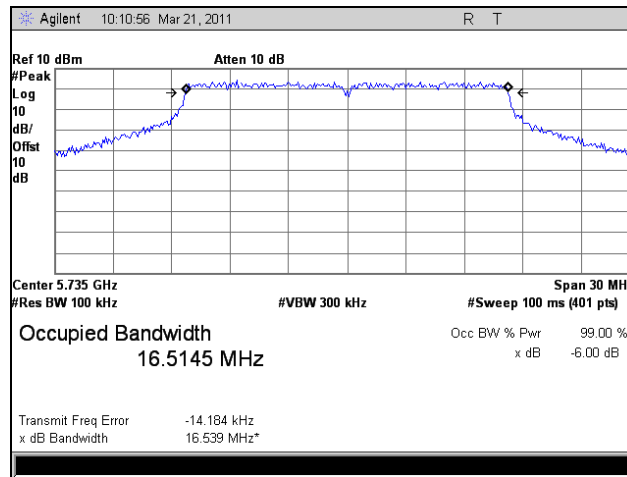

Plot 7. 6 dB Occupied Bandwidth, 802.11a 20 MHz, Low Channel

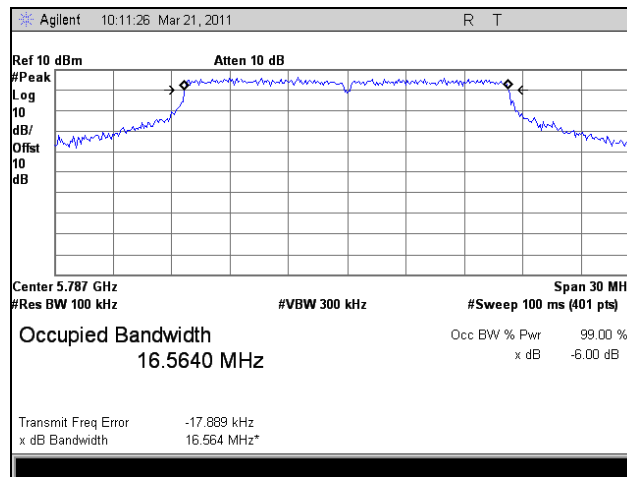

Plot 8. 6 dB Occupied Bandwidth, 802.11a 20 MHz, Mid Channel

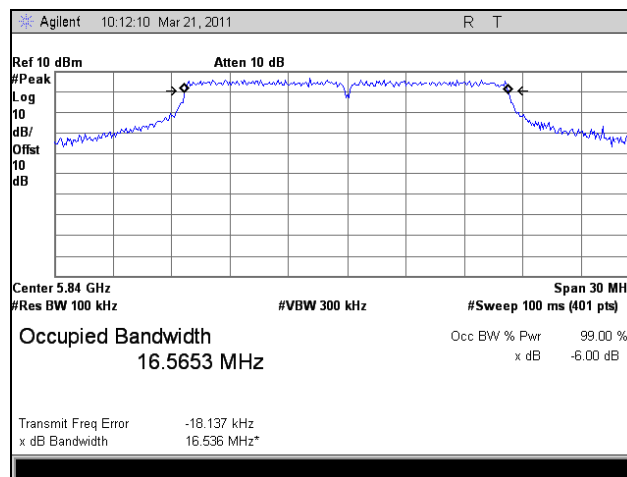

Plot 9. 6 dB Occupied Bandwidth, 802.11a 20 MHz, High Channel

6 dB Occupied Bandwidth Test Results, 802.11a 40 MHz

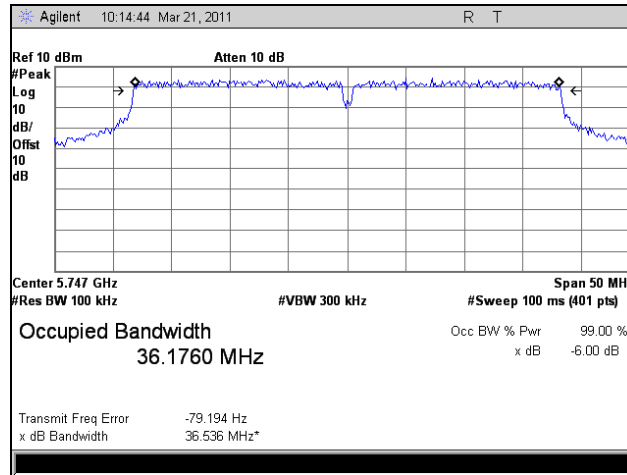

Plot 10. 6 dB Occupied Bandwidth, 802.11a 40 MHz, Low Channel

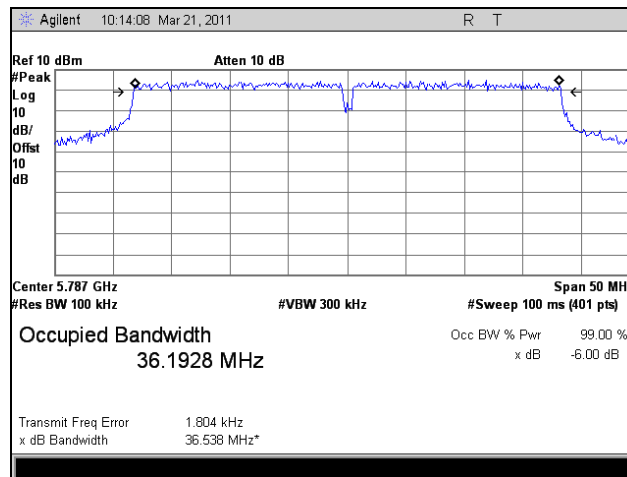

Plot 11. 6 dB Occupied Bandwidth, 802.11a 40 MHz, Mid Channel

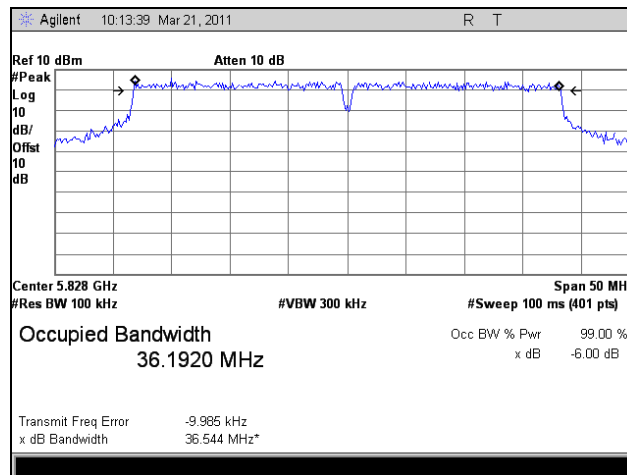

Plot 12. 6 dB Occupied Bandwidth, 802.11a 40 MHz, High Channel

6 dB Occupied Bandwidth Test Results, HT5, Port 1

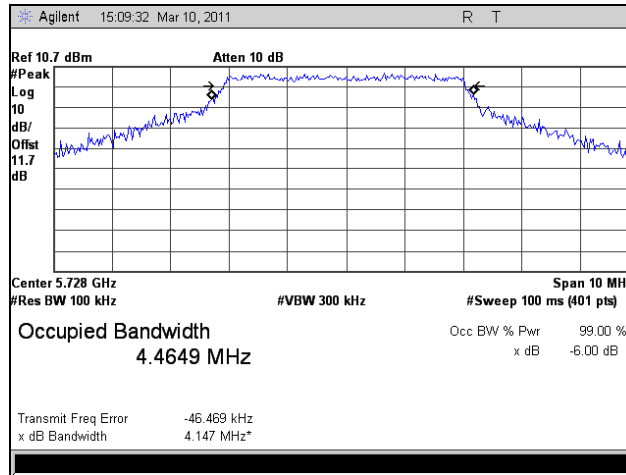

Plot 13. 6 dB Occupied Bandwidth, HT5, Port 1, Low Channel

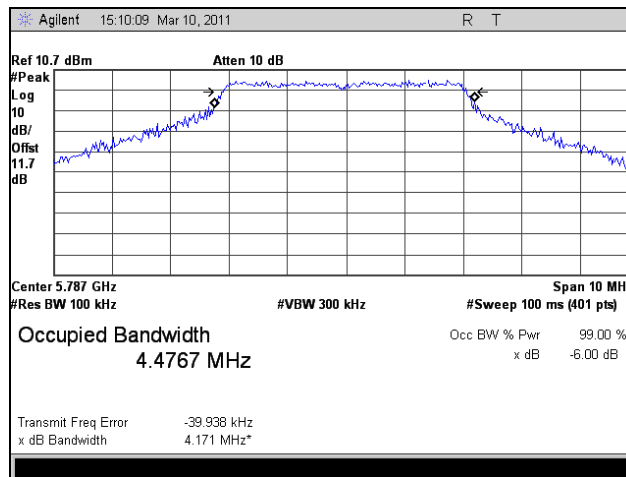

Plot 14. 6 dB Occupied Bandwidth, HT5, Port 1, Mid Channel

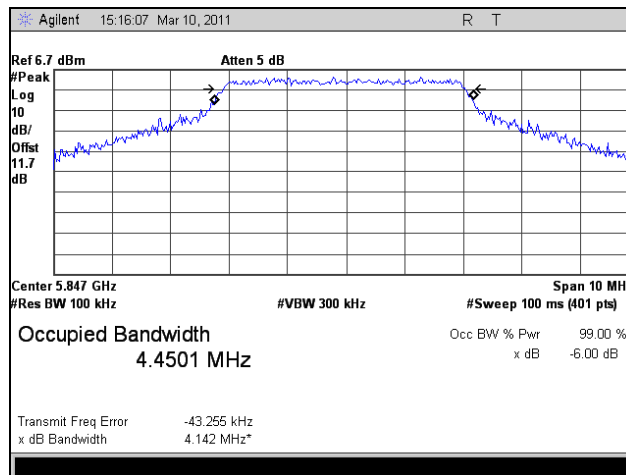

Plot 15. 6 dB Occupied Bandwidth, HT5, Port 1, High Channel

6 dB Occupied Bandwidth Test Results, HT5, Port 2

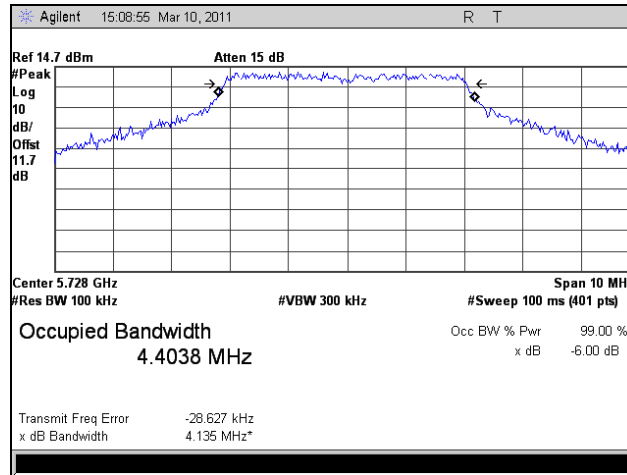

Plot 16. 6 dB Occupied Bandwidth, HT5, Port 2, Low Channel

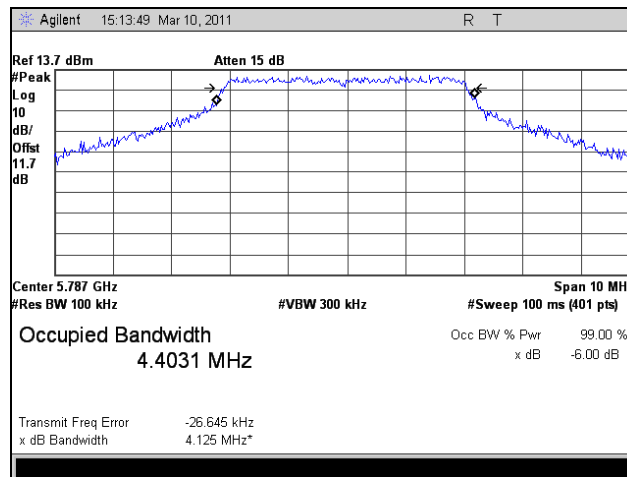

Plot 17. 6 dB Occupied Bandwidth, HT5, Port 2, Mid Channel

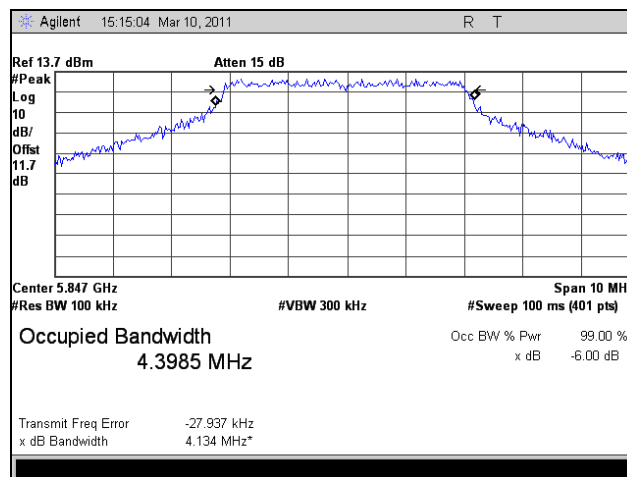

Plot 18. 6 dB Occupied Bandwidth, HT5, Port 2, High Channel

6 dB Occupied Bandwidth Test Results, HT8, Port 1

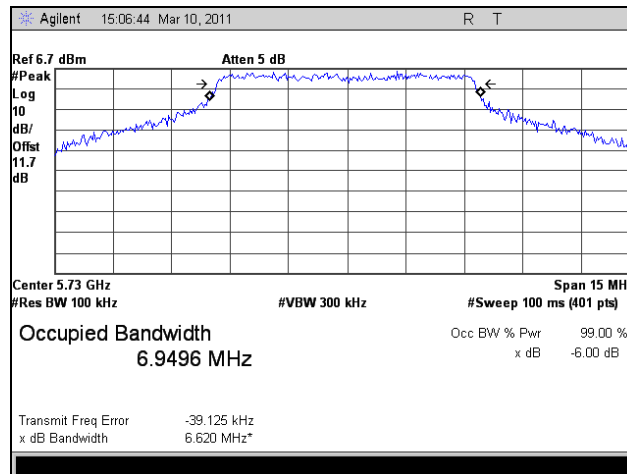

Plot 19. 6 dB Occupied Bandwidth, HT8, Port 1, Low Channel

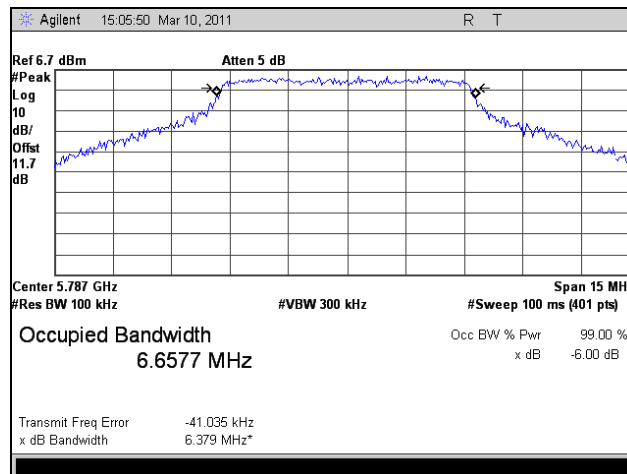

Plot 20. 6 dB Occupied Bandwidth, HT8, Port 1, Mid Channel

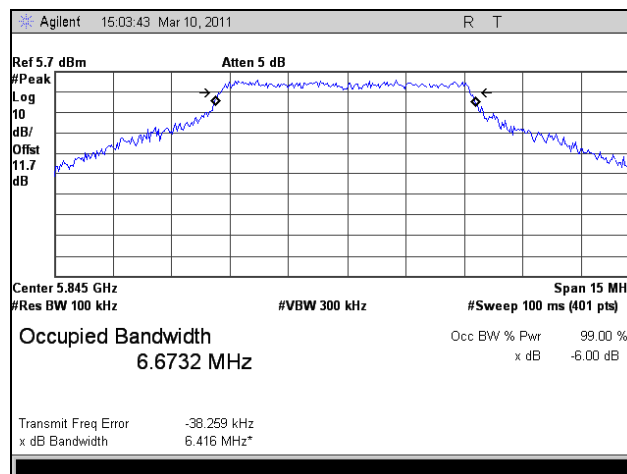

Plot 21. 6 dB Occupied Bandwidth, HT8, Port 1, High Channel

6 dB Occupied Bandwidth Test Results, HT8, Port 2

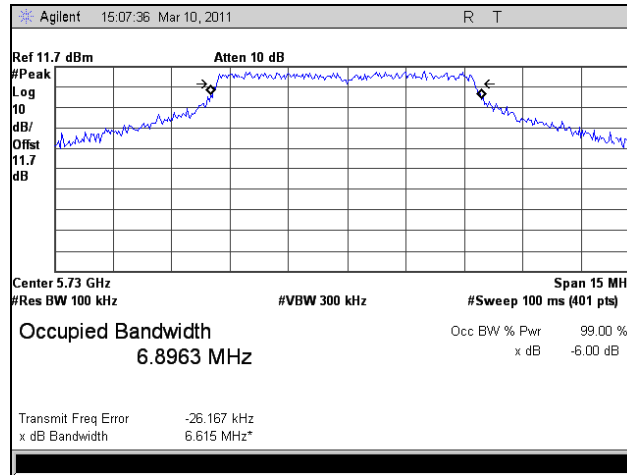

Plot 22. 6 dB Occupied Bandwidth, HT8, Port 2, Low Channel

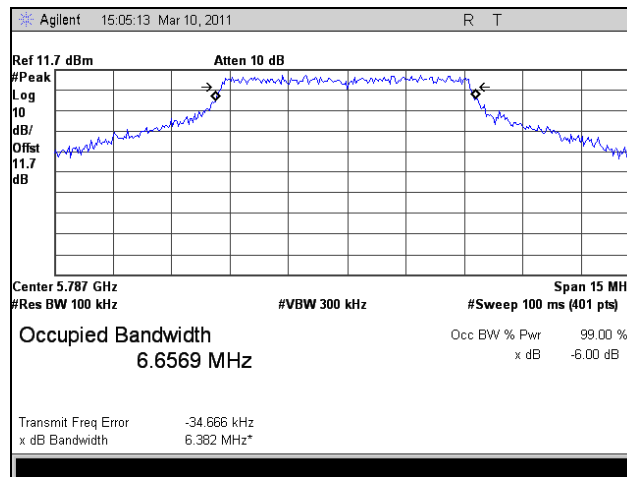

Plot 23. 6 dB Occupied Bandwidth, HT8, Port 2, Mid Channel

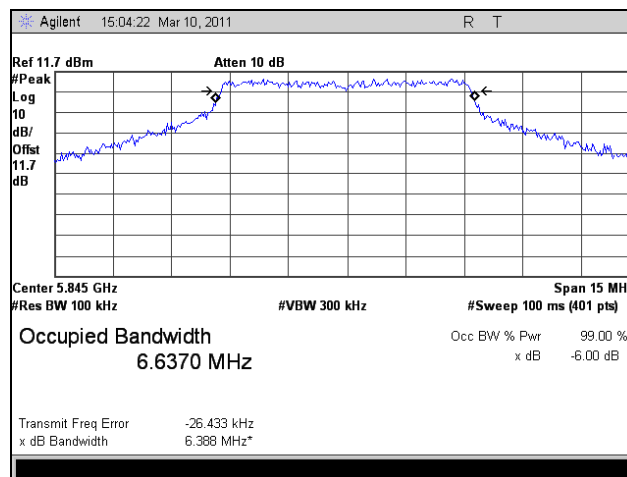

Plot 24. 6 dB Occupied Bandwidth, HT8, Port 2, High Channel

6 dB Occupied Bandwidth Test Results, HT10, Port 1

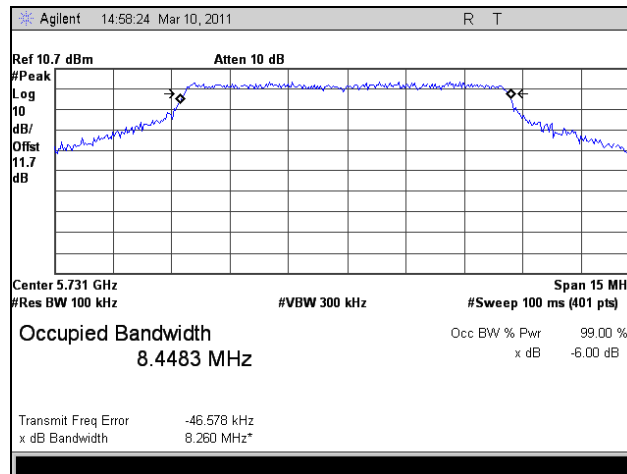

Plot 25. 6 dB Occupied Bandwidth, HT10, Port 1, Low Channel

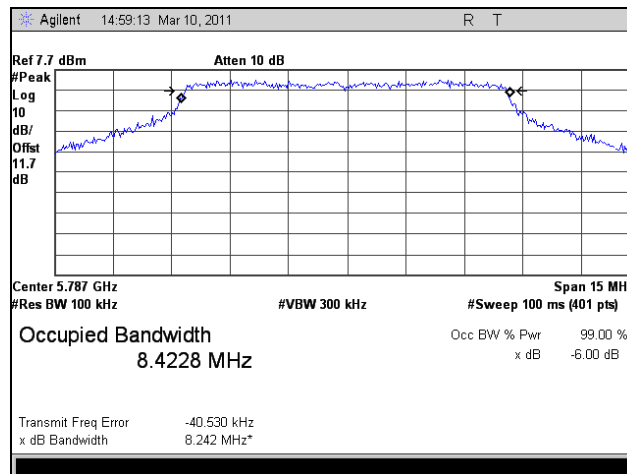

Plot 26. 6 dB Occupied Bandwidth, HT10, Port 1, Mid Channel

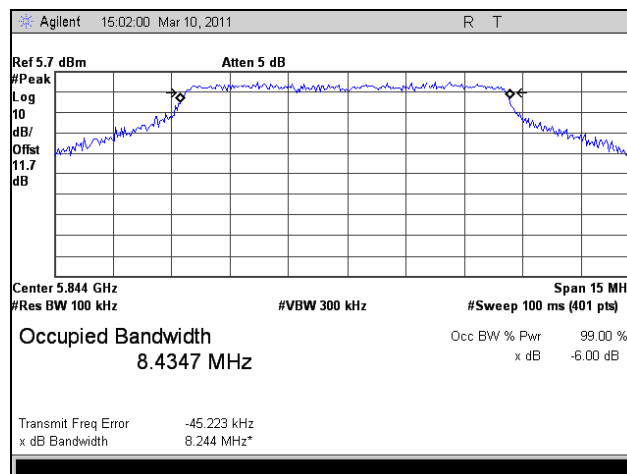

Plot 27. 6 dB Occupied Bandwidth, HT10, Port 1, High Channel

6 dB Occupied Bandwidth Test Results, HT10, Port 2

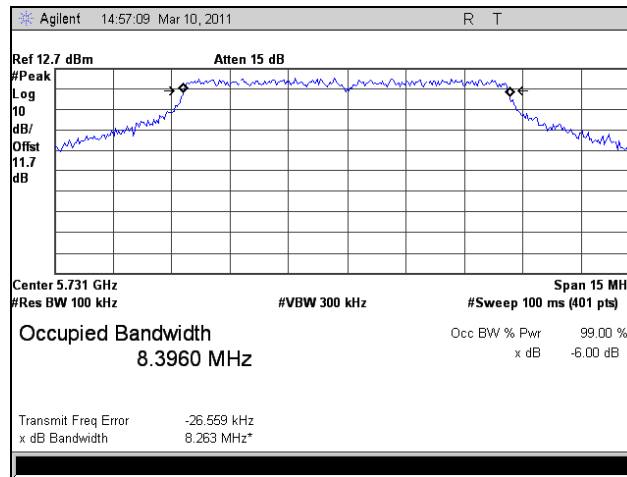

Plot 28. 6 dB Occupied Bandwidth, HT10, Port 2, Low Channel

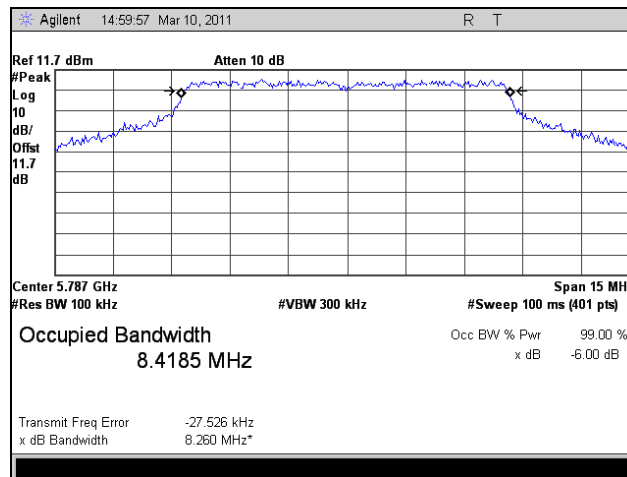

Plot 29. 6 dB Occupied Bandwidth, HT10, Port 2, Mid Channel

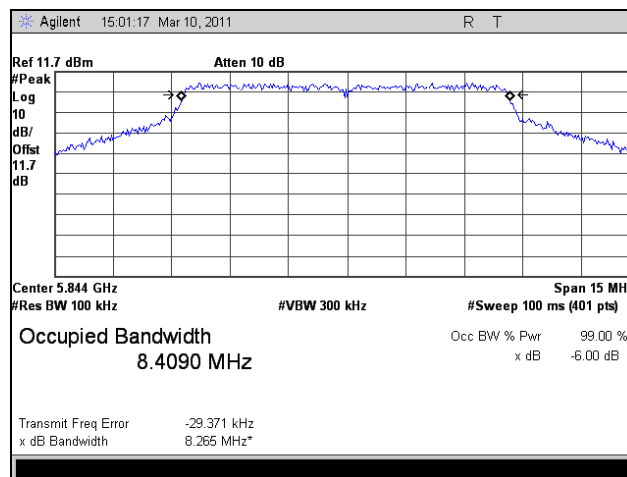

Plot 30. 6 dB Occupied Bandwidth, HT10, Port 2, High Channel

6 dB Occupied Bandwidth Test Results, HT20, Port 1

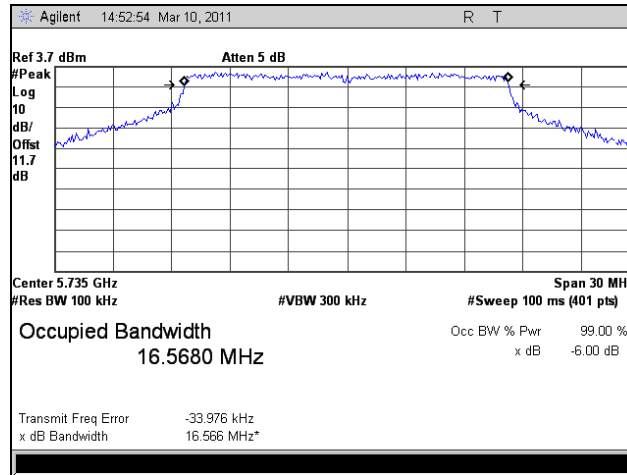

Plot 31. 6 dB Occupied Bandwidth, HT20, Port 1, Low Channel

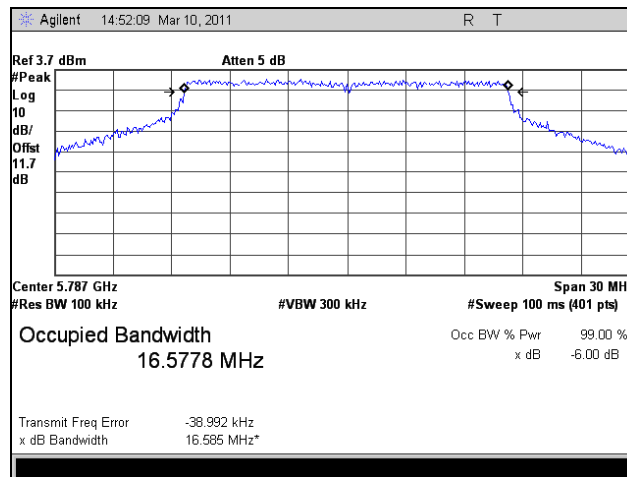

Plot 32. 6 dB Occupied Bandwidth, HT20, Port 1, Mid Channel

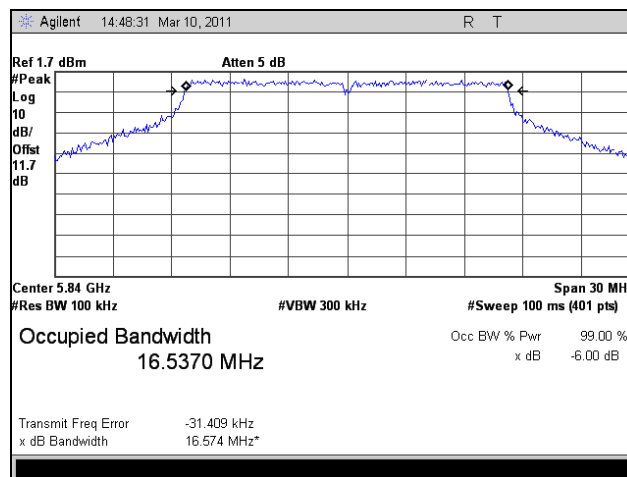

Plot 33. 6 dB Occupied Bandwidth, HT20, Port 1, High Channel

6 dB Occupied Bandwidth Test Results, HT20, Port 2

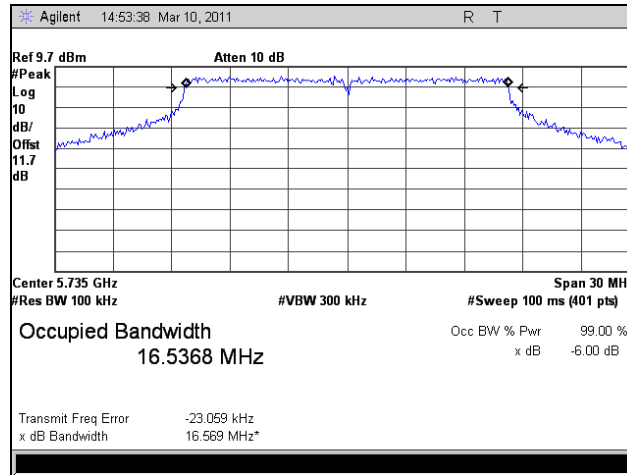

Plot 34. 6 dB Occupied Bandwidth, HT20, Port 2, Low Channel

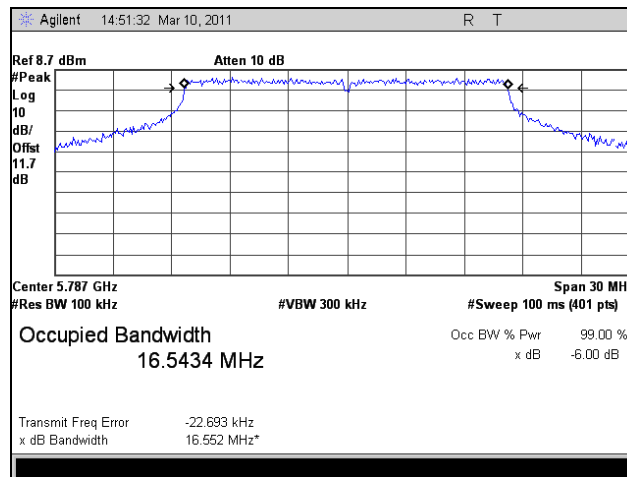

Plot 35. 6 dB Occupied Bandwidth, HT20, Port 2, Mid Channel

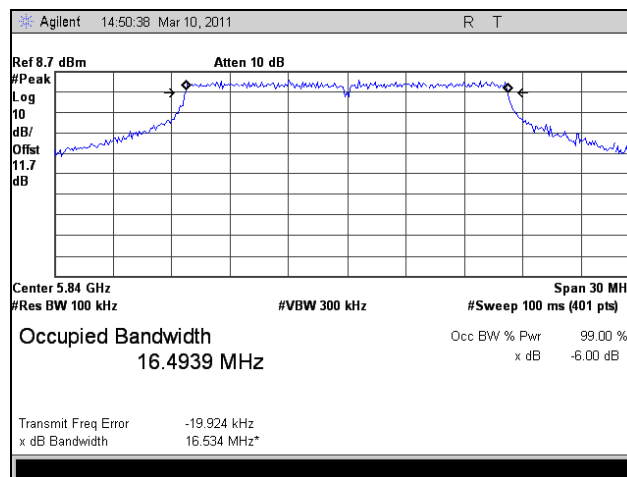

Plot 36. 6 dB Occupied Bandwidth, HT20, Port 2, High Channel

6 dB Occupied Bandwidth Test Results, HT30, Port 1

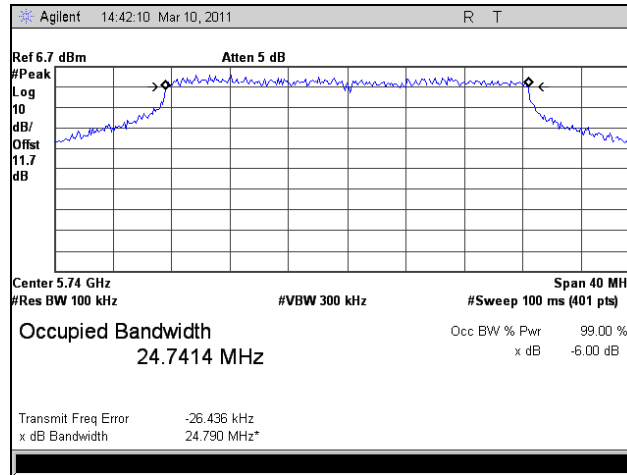

Plot 37. 6 dB Occupied Bandwidth, HT30, Port 1, Low Channel

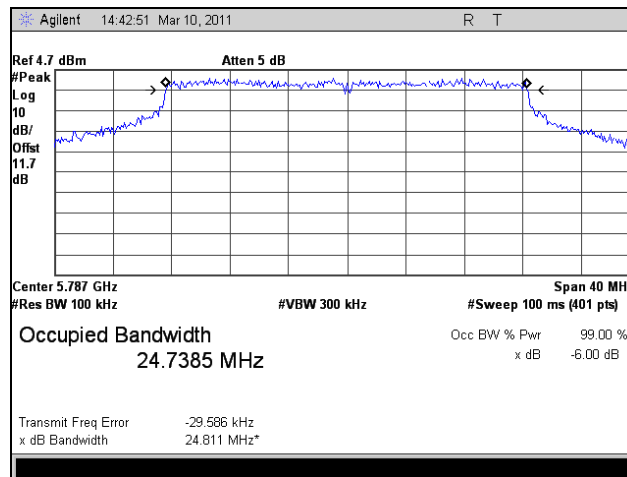

Plot 38. 6 dB Occupied Bandwidth, HT30, Port 1, Mid Channel

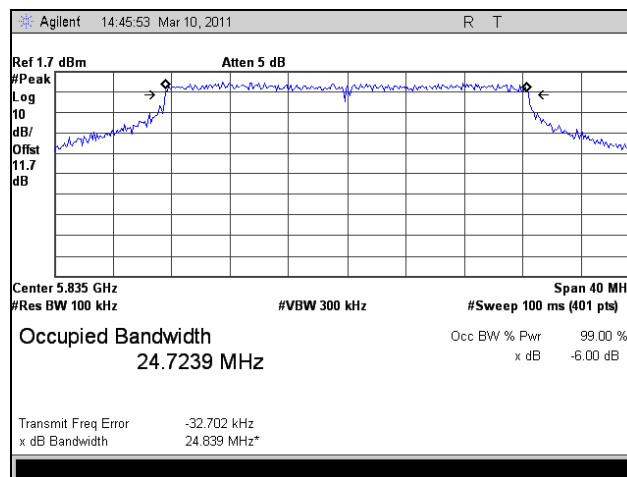

Plot 39. 6 dB Occupied Bandwidth, HT30, Port 1, High Channel

6 dB Occupied Bandwidth Test Results, HT30, Port 2

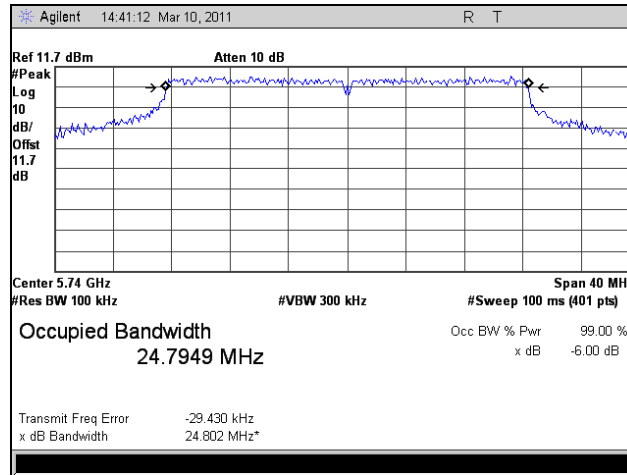

Plot 40. 6 dB Occupied Bandwidth, HT30, Port 2, Low Channel

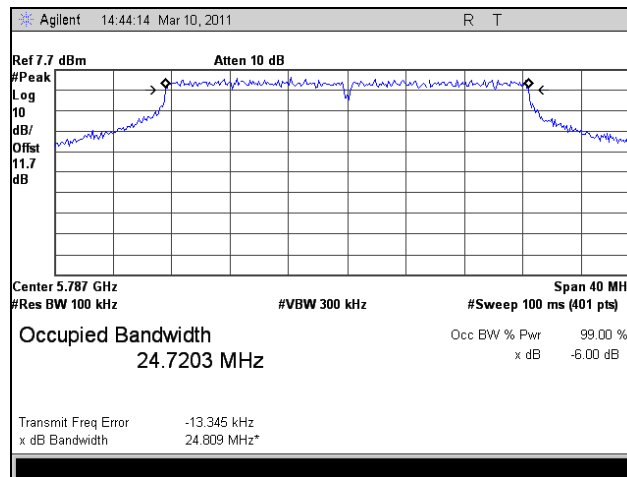

Plot 41. 6 dB Occupied Bandwidth, HT30, Port 2, Mid Channel

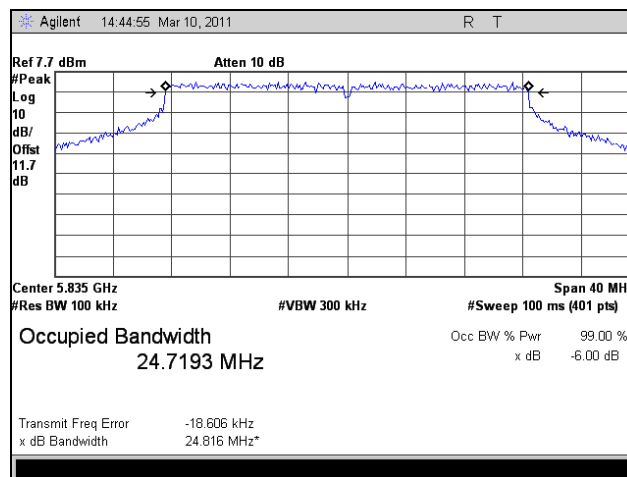

Plot 42. 6 dB Occupied Bandwidth, HT30, Port 2, High Channel

6 dB Occupied Bandwidth Test Results, HT40, Port 1

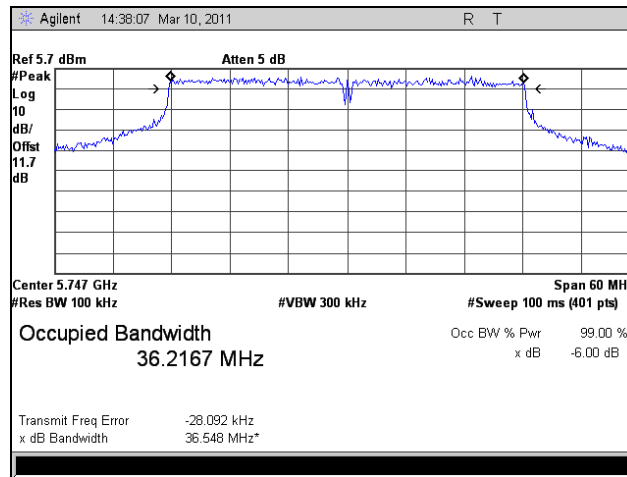

Plot 43. 6 dB Occupied Bandwidth, HT40, Port 1, Low Channel

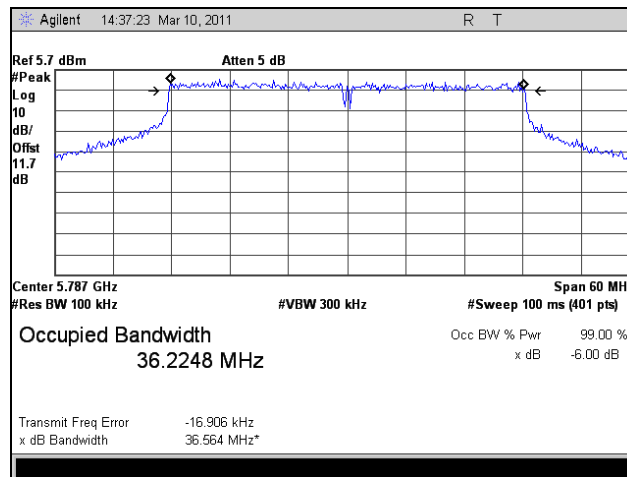

Plot 44. 6 dB Occupied Bandwidth, HT40, Port 1, Mid Channel

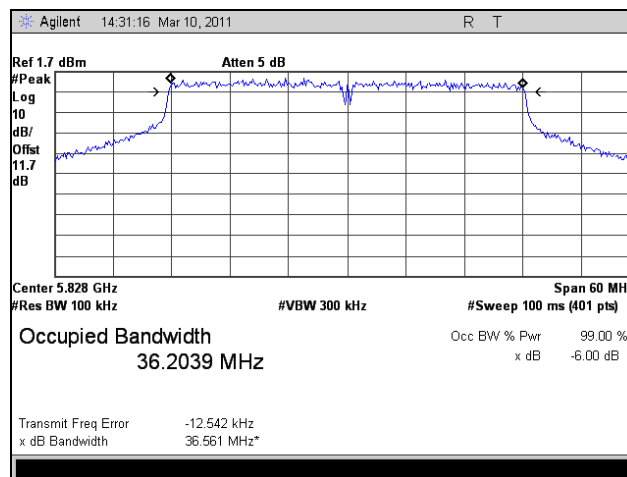

Plot 45. 6 dB Occupied Bandwidth, HT40, Port 1, High Channel

6 dB Occupied Bandwidth Test Results, HT40, Port 2

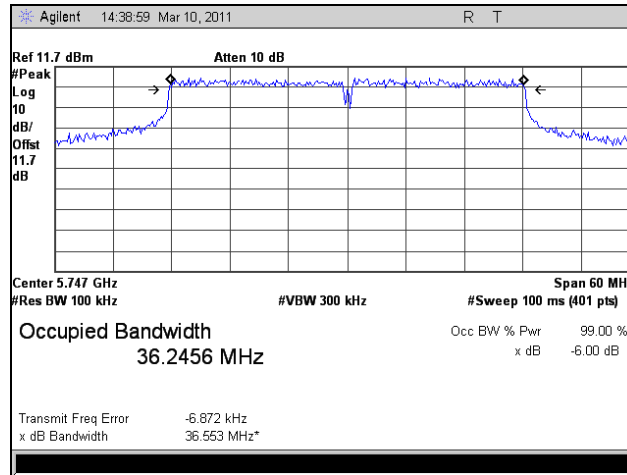

Plot 46. 6 dB Occupied Bandwidth, HT40, Port 2, Low Channel

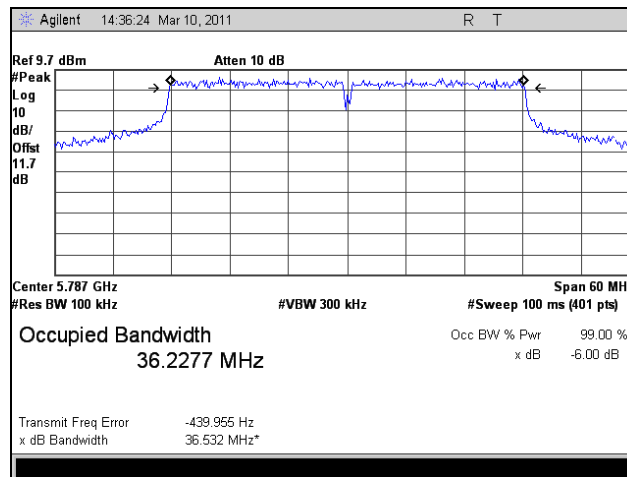

Plot 47. 6 dB Occupied Bandwidth, HT40, Port 2, Mid Channel

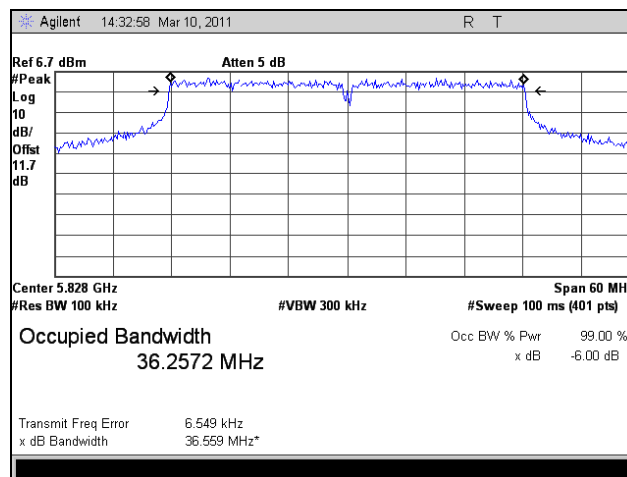

Plot 48. 6 dB Occupied Bandwidth, HT40, Port 2, High Channel

99% Occupied Bandwidth Test Results, 802.11a 20 MHz

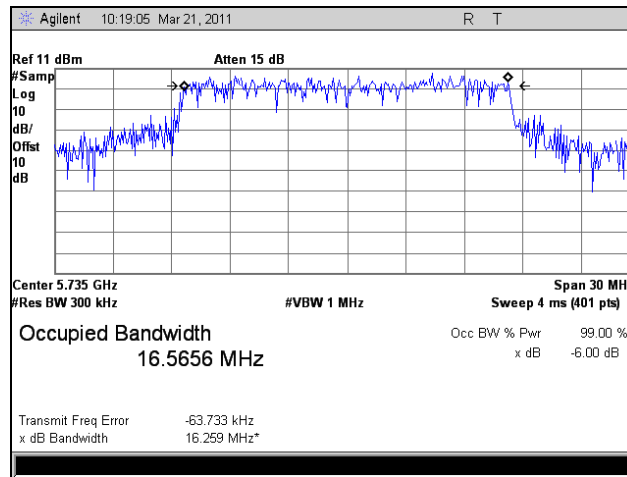

Plot 49. 99% Occupied Bandwidth, 802.11a 20 MHz, Low Channel

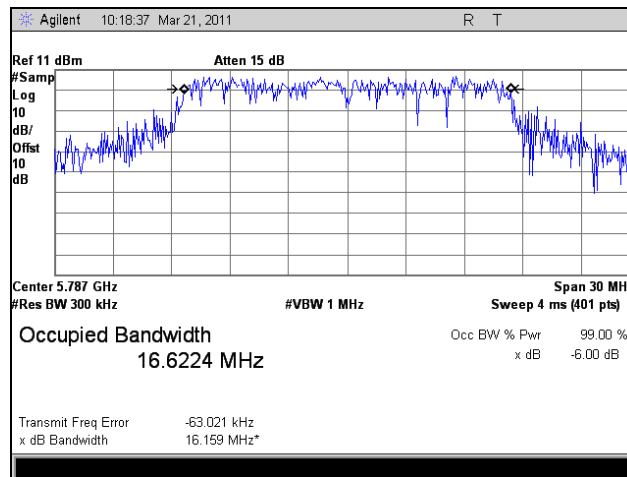

Plot 50. 99% Occupied Bandwidth, 802.11a 20 MHz, Mid Channel

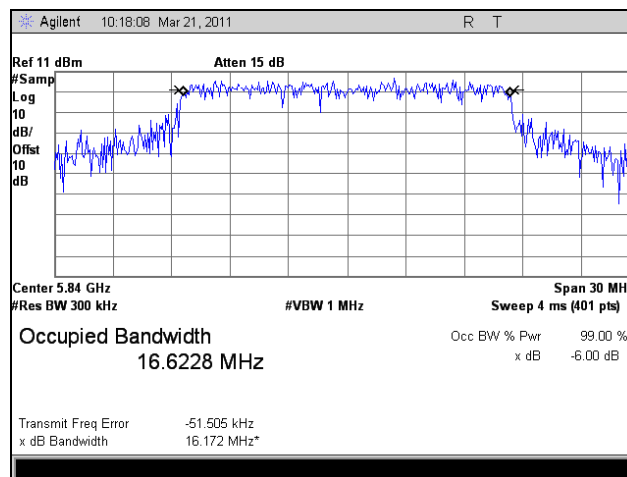

Plot 51. 99% Occupied Bandwidth, 802.11a 20 MHz, High Channel

99% Occupied Bandwidth Test Results, 802.11a 40 MHz

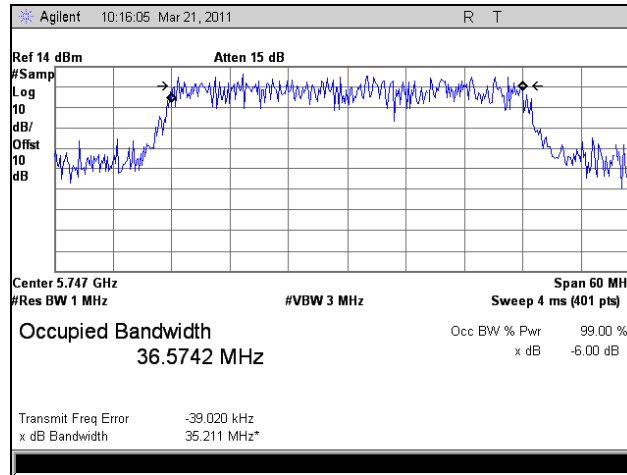

Plot 52. 99% Occupied Bandwidth, 802.11a 40 MHz, Low Channel

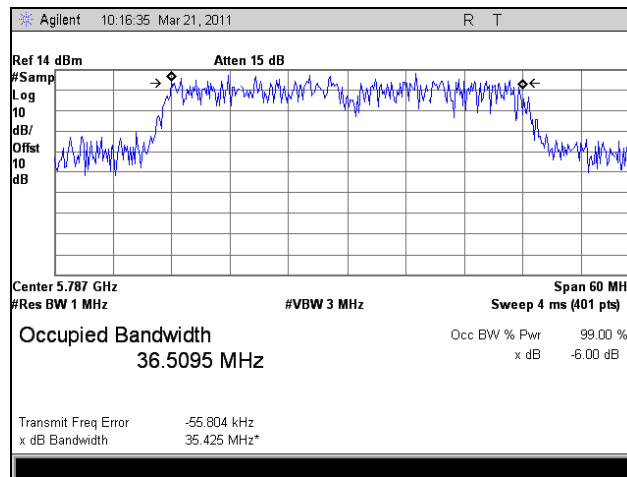

Plot 53. 99% Occupied Bandwidth, 802.11a 40 MHz, Mid Channel

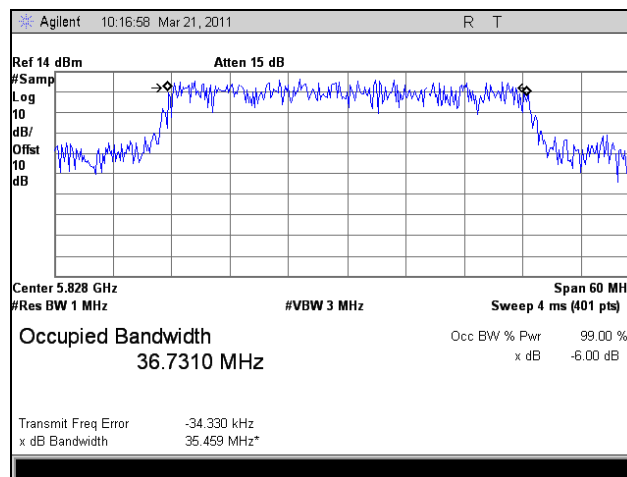

Plot 54. 99% Occupied Bandwidth, 802.11a 40 MHz, High Channel

99% Occupied Bandwidth Test Results, HT5, Port 1

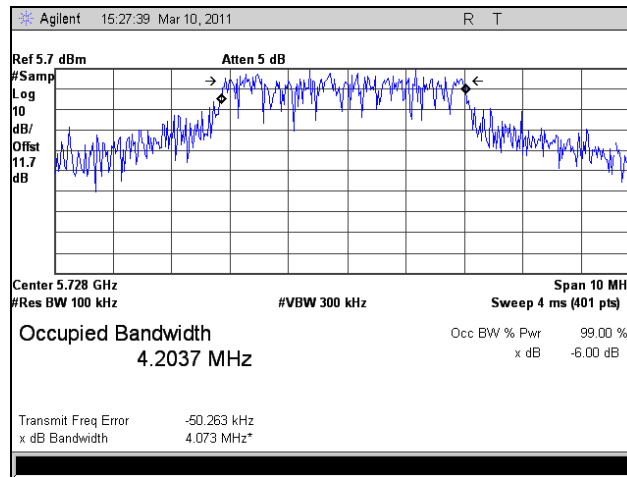

Plot 55. 99% Occupied Bandwidth, HT5, Port 1, Low Channel

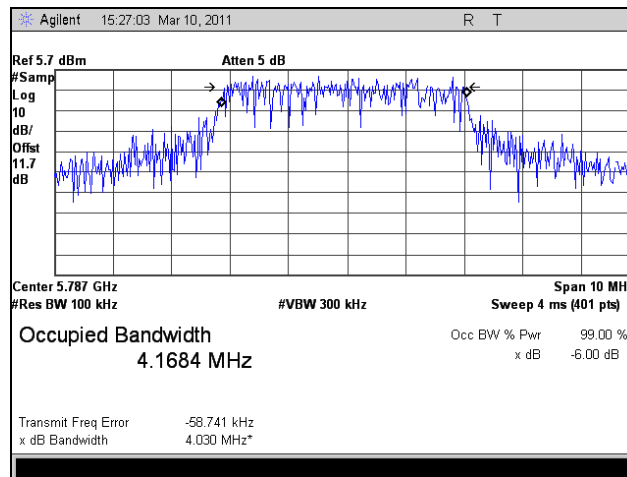

Plot 56. 99% Occupied Bandwidth, HT5, Port 1, Mid Channel

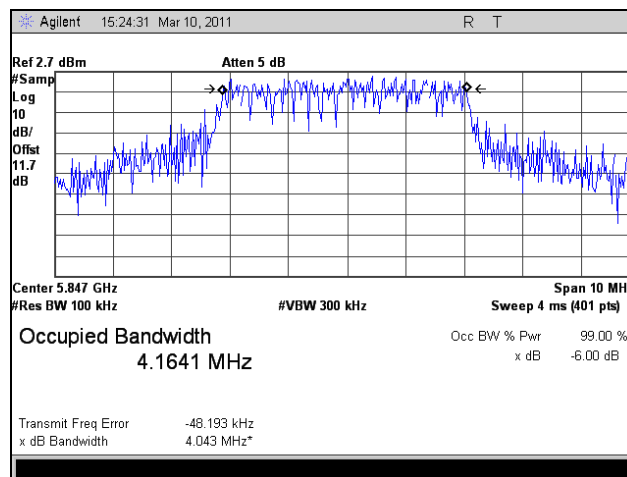

Plot 57. 99% Occupied Bandwidth, HT5, Port 1, High Channel

99% Occupied Bandwidth Test Results, HT5, Port 2

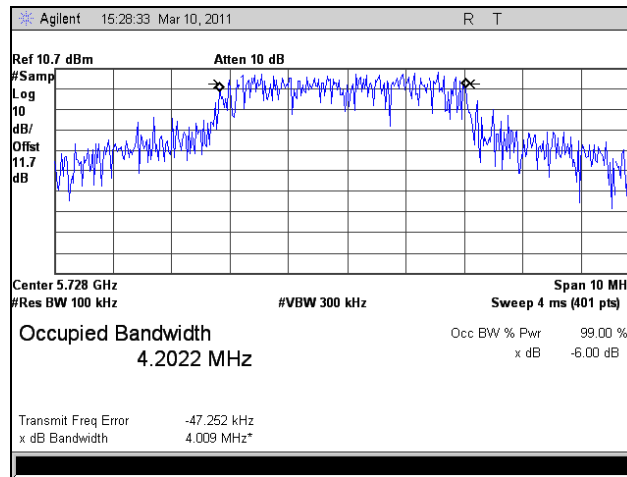

Plot 58. 99% Occupied Bandwidth, HT5, Port 2, Low Channel

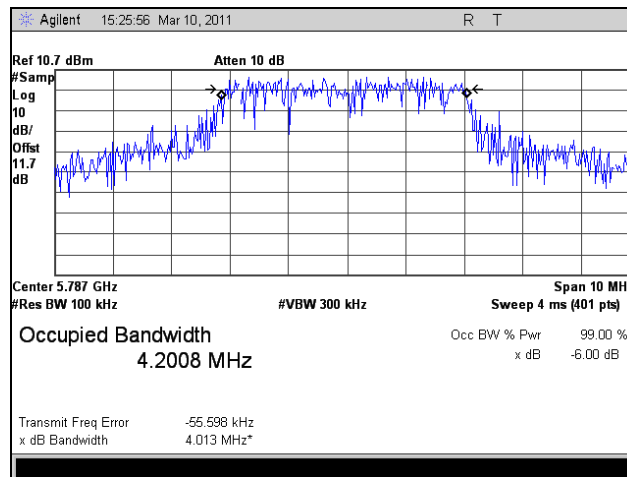

Plot 59. 99% Occupied Bandwidth, HT5, Port 2, Mid Channel

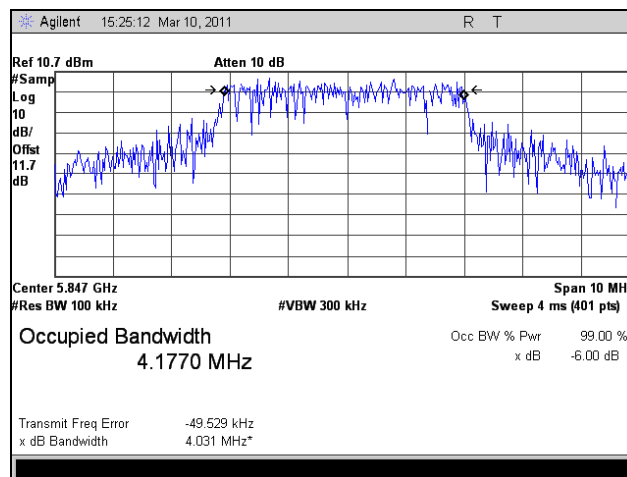

Plot 60. 99% Occupied Bandwidth, HT5, Port 2, High Channel

99% Occupied Bandwidth Test Results, HT8, Port 1

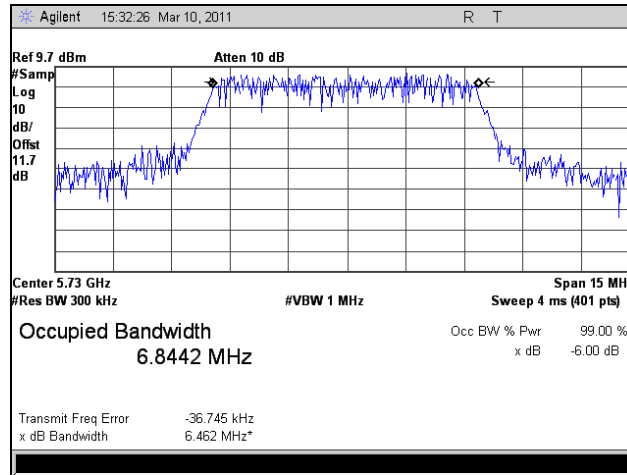

Plot 61. 99% Occupied Bandwidth, HT8, Port 1, Low Channel

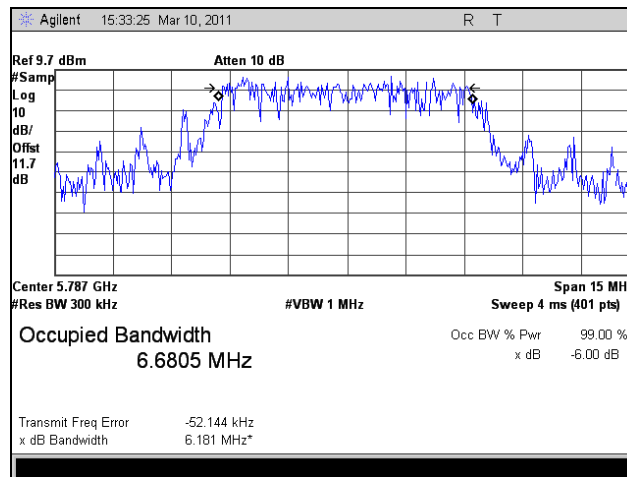

Plot 62. 99% Occupied Bandwidth, HT8, Port 1, Mid Channel

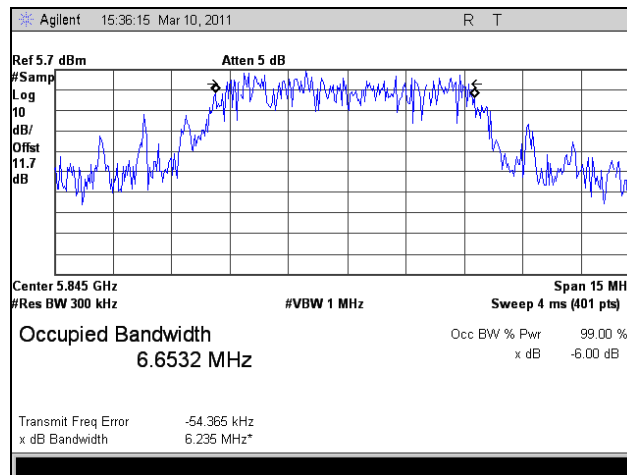

Plot 63. 99% Occupied Bandwidth, HT8, Port 1, High Channel

99% Occupied Bandwidth Test Results, HT8, Port 2

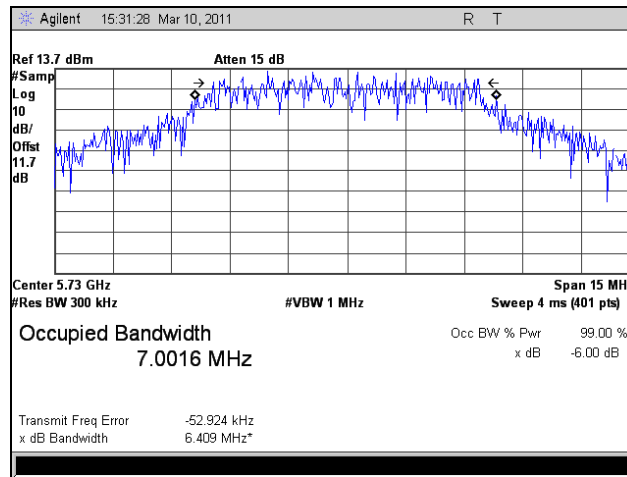

Plot 64. 99% Occupied Bandwidth, HT8, Port 2, Low Channel

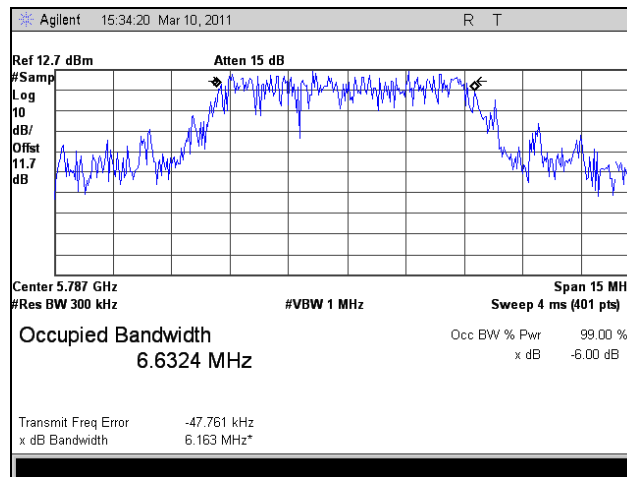

Plot 65. 99% Occupied Bandwidth, HT8, Port 2, Mid Channel

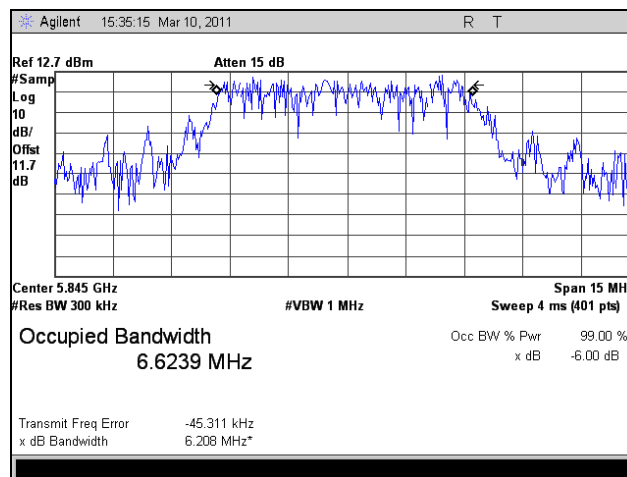

Plot 66. 99% Occupied Bandwidth, HT8, Port 2, High Channel

99% Occupied Bandwidth Test Results, HT10, Port 1

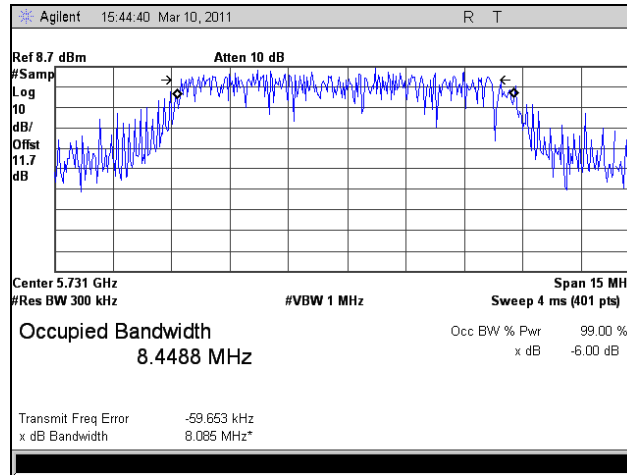

Plot 67. 99% Occupied Bandwidth, HT10, Port 1, Low Channel

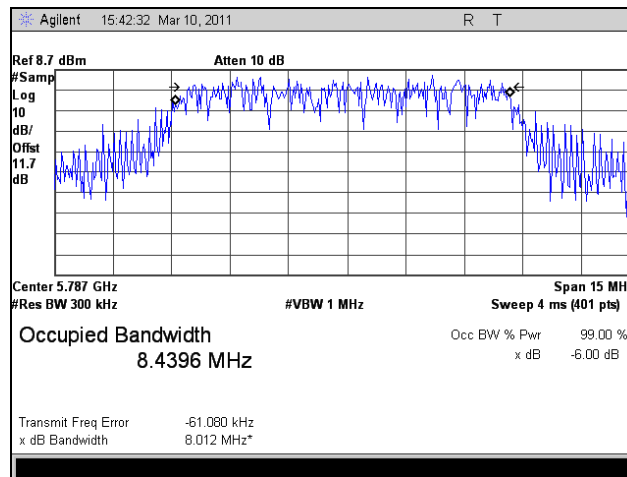

Plot 68. 99% Occupied Bandwidth, HT10, Port 1, Mid Channel

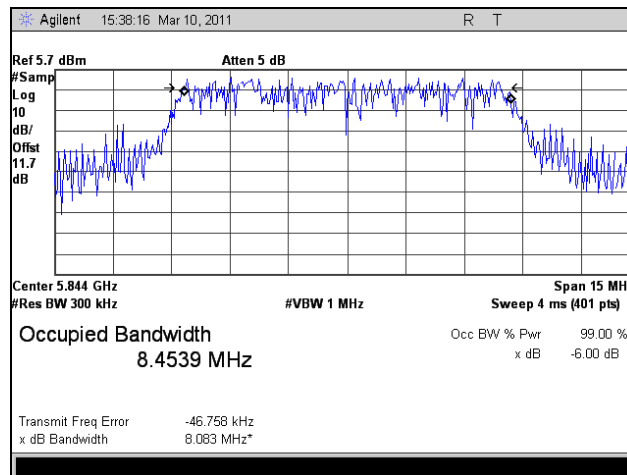

Plot 69. 99% Occupied Bandwidth, HT10, Port 1, High Channel

99% Occupied Bandwidth Test Results, HT10, Port 2

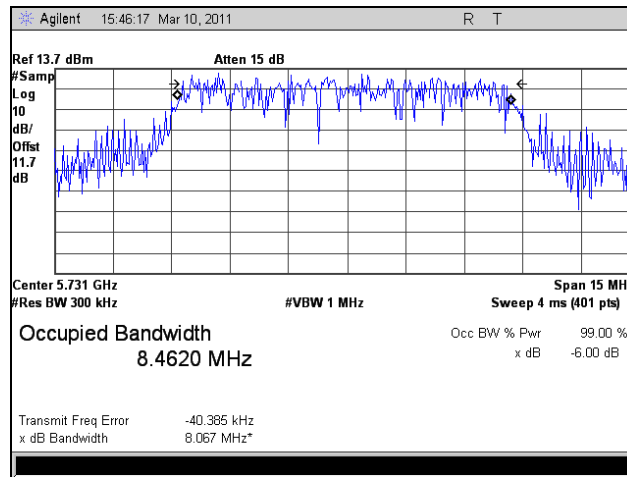

Plot 70. 99% Occupied Bandwidth, HT10, Port 2, Low Channel

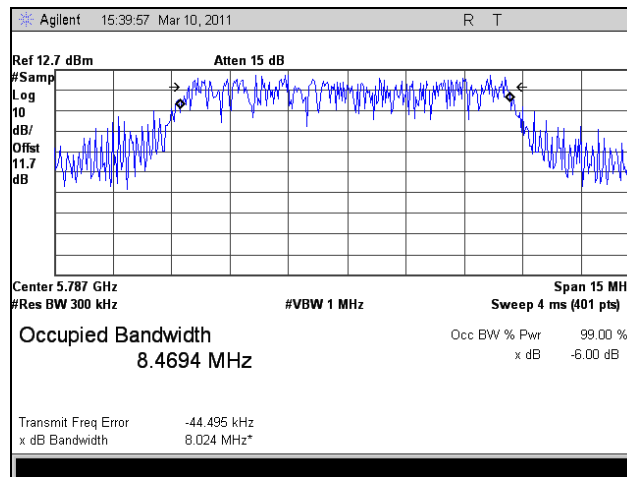

Plot 71. 99% Occupied Bandwidth, HT10, Port 2, Mid Channel

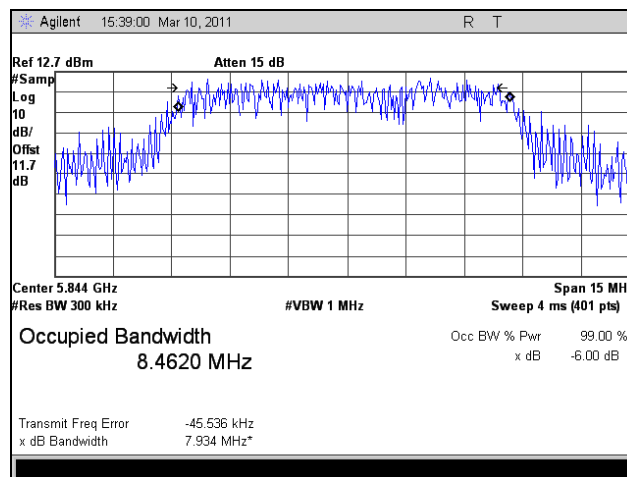

Plot 72. 99% Occupied Bandwidth, HT10, Port 2, High Channel

99% Occupied Bandwidth Test Results, HT20, Port 1

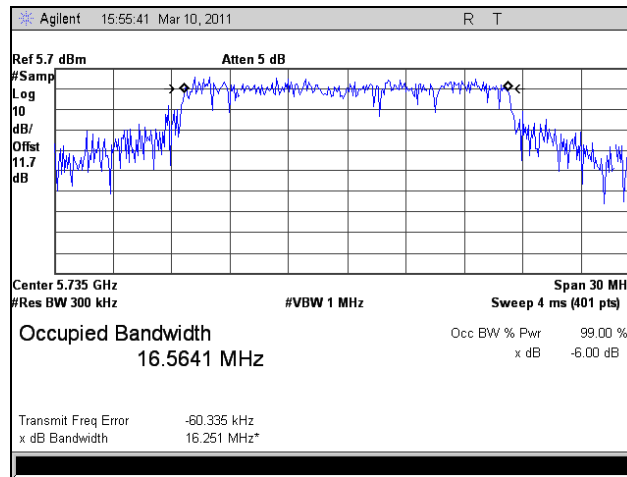

Plot 73. 99% Occupied Bandwidth, HT20, Port 1, Low Channel

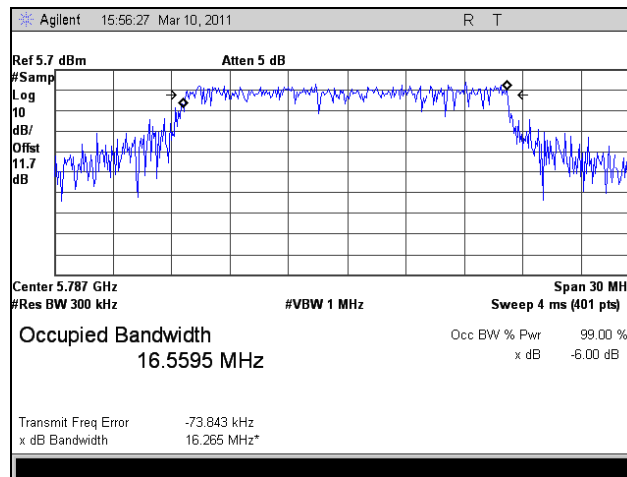

Plot 74. 99% Occupied Bandwidth, HT20, Port 1, Mid Channel

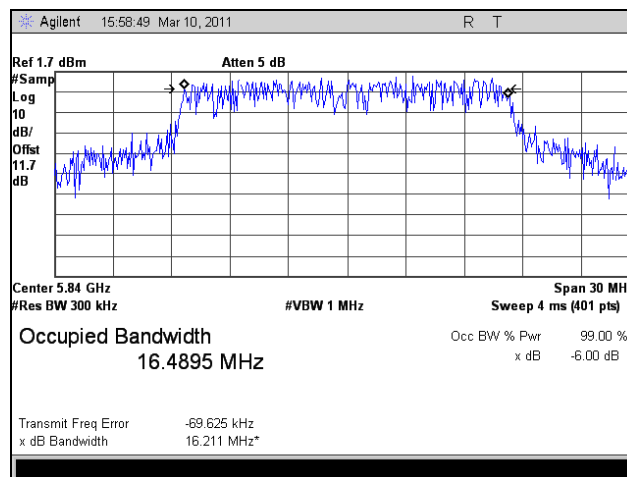

Plot 75. 99% Occupied Bandwidth, HT20, Port 1, High Channel

99% Occupied Bandwidth Test Results, HT20, Port 2

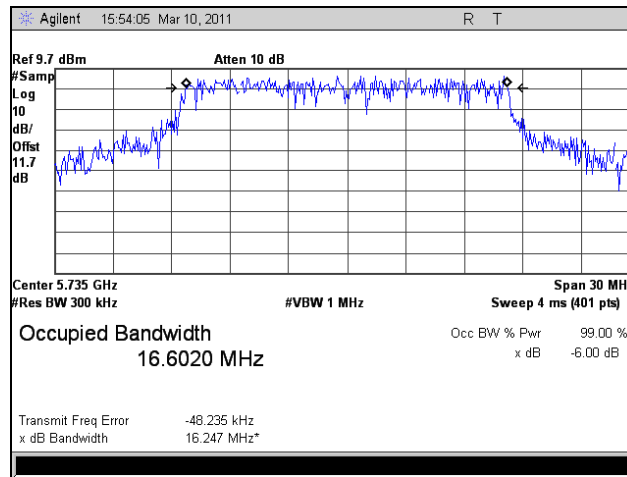

Plot 76. 99% Occupied Bandwidth, HT20, Port 2, Low Channel

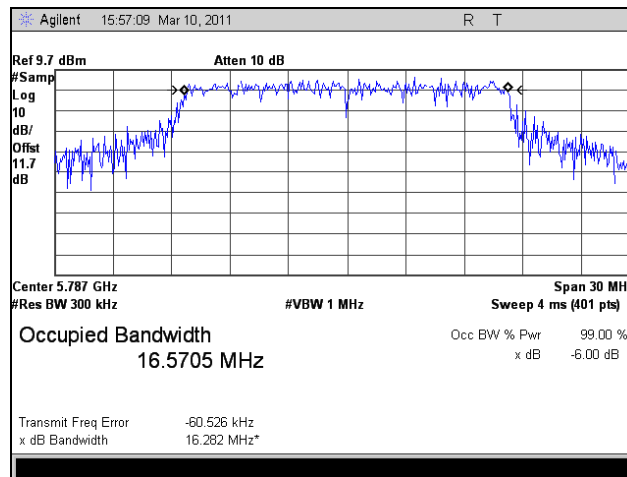

Plot 77. 99% Occupied Bandwidth, HT20, Port 2, Mid Channel

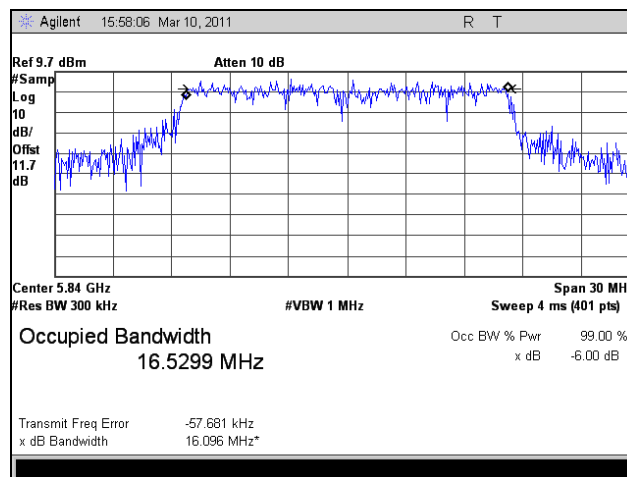

Plot 78. 99% Occupied Bandwidth, HT20, Port 2, High Channel

99% Occupied Bandwidth Test Results, HT30, Port 1

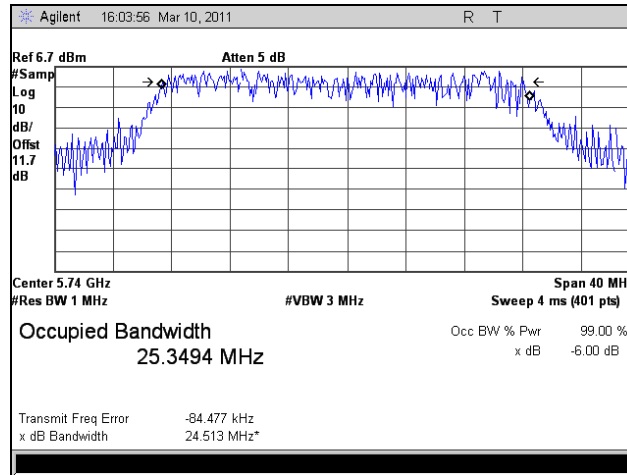

Plot 79. 99% Occupied Bandwidth, HT30, Port 1, Low Channel

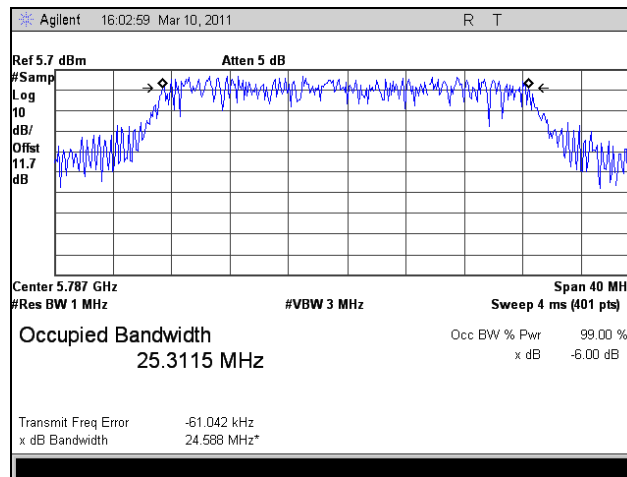

Plot 80. 99% Occupied Bandwidth, HT30, Port 1, Mid Channel

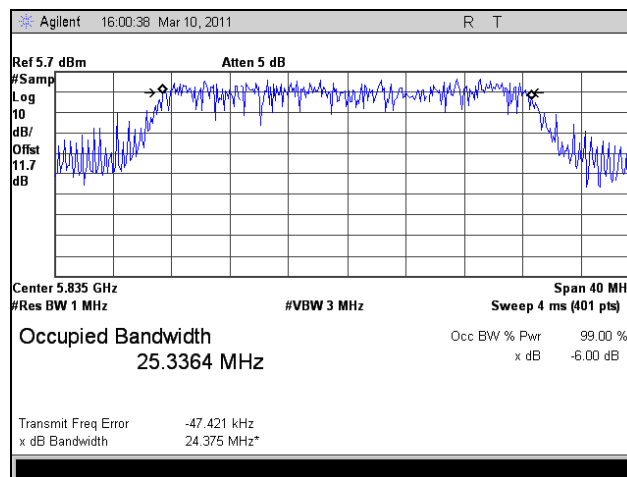

Plot 81. 99% Occupied Bandwidth, HT30, Port 1, High Channel

99% Occupied Bandwidth Test Results, HT30, Port 2

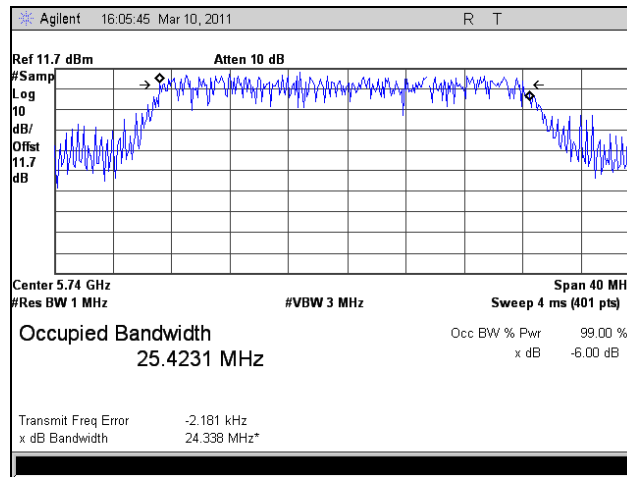

Plot 82. 99% Occupied Bandwidth, HT30, Port 2, Low Channel

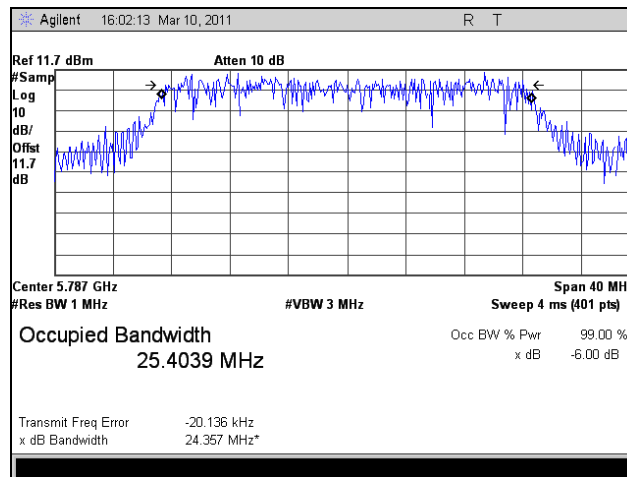

Plot 83. 99% Occupied Bandwidth, HT30, Port 2, Mid Channel

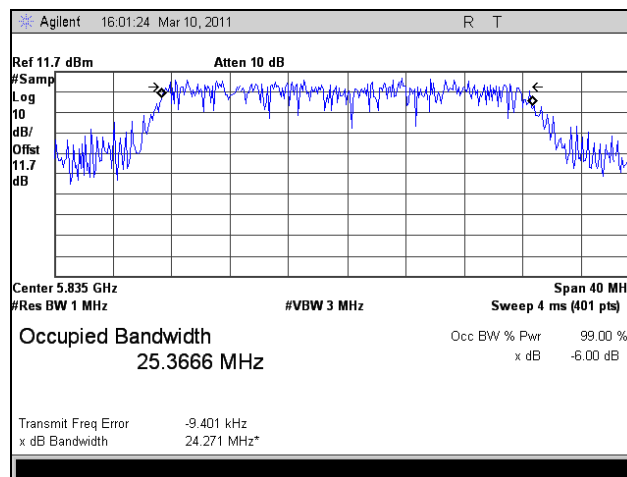

Plot 84. 99% Occupied Bandwidth, HT30, Port 2, High Channel

99% Occupied Bandwidth Test Results, HT40, Port 1

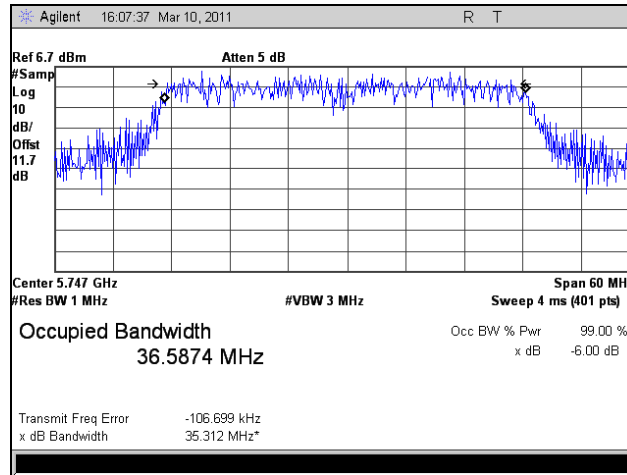

Plot 85. 99% Occupied Bandwidth, HT40, Port 1, Low Channel

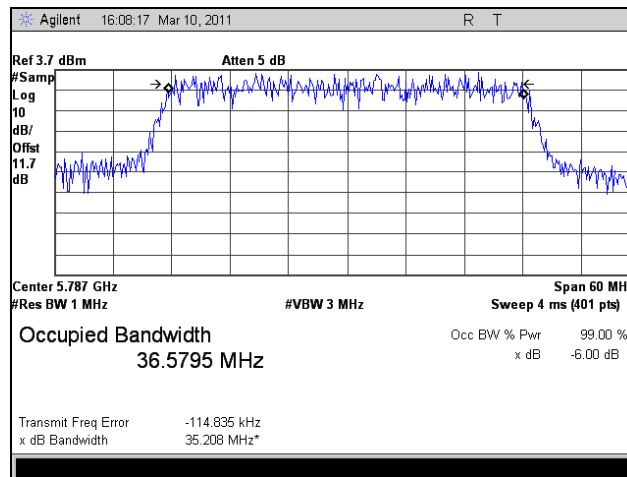

Plot 86. 99% Occupied Bandwidth, HT40, Port 1, Mid Channel

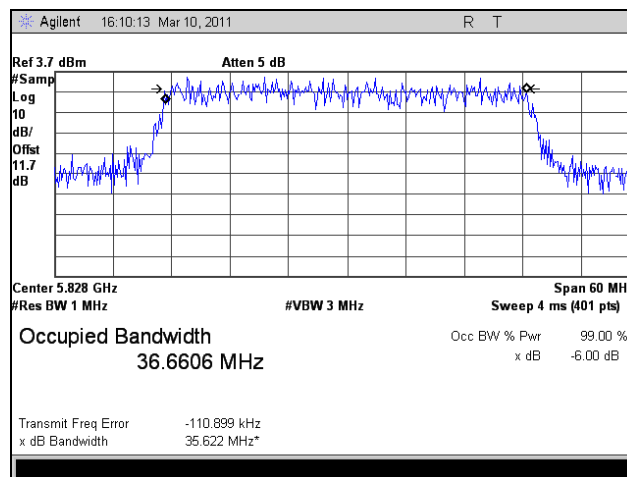

Plot 87. 99% Occupied Bandwidth, HT40, Port 1, High Channel

99% Occupied Bandwidth Test Results, HT40, Port 2

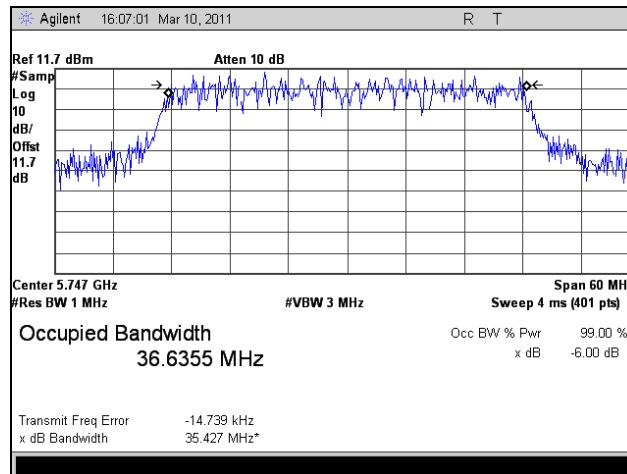

Plot 88. 99% Occupied Bandwidth, HT40, Port 2, Low Channel

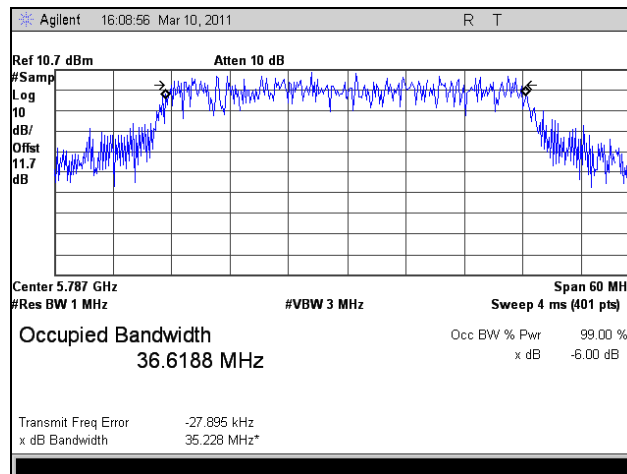

Plot 89. 99% Occupied Bandwidth, HT40, Port 2, Mid Channel

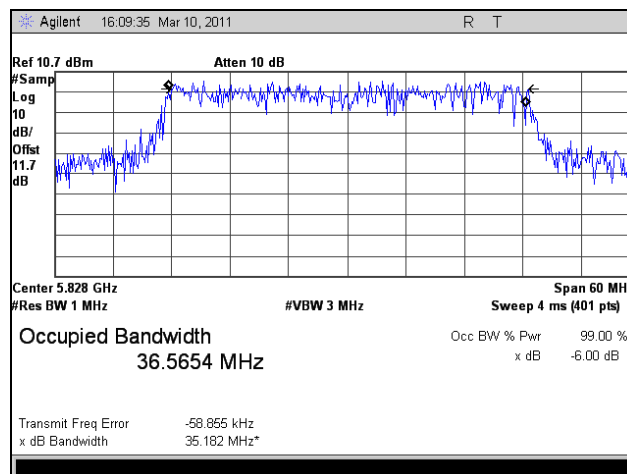

Plot 90. 99% Occupied Bandwidth, HT40, Port 2, High Channel

Electromagnetic Compatibility Criteria for Intentional Radiators

§ 15.247(b) Peak Power Output

Test Requirements: §15.247(b): The maximum peak output power of the intentional radiator shall not exceed the following:

Digital Transmission Systems (MHz)	Output Limit (Watts)
902-928	1.000
2400-2483.5	1.000
5725- 5850	1.000

Table 19. Output Power Requirements from §15.247(b)

§15.247(c): if transmitting antennas of directional gain greater than 6 dBi are used the peak output power from the intentional radiator shall be reduced below the stated values in the Table 19, as appropriate, by the amount in dB that the directional gain of the antenna exceeds 6 dBi.

Systems operating in the 2400 – 2483.5 MHz band and using a point to point application may employ transmitting antennas with directional gain greater than 6 dBi provided the maximum peak output power of the intentional radiator is reduced by 1 dB for every 3 dB that the directional gain of the antenna exceeds 6 dBi.

Systems operating in the 5725 – 5850 MHz band that are used exclusively for fixed, point-to-point operations may employ transmitting antennas with directional gain greater than 6 dBi without any corresponding reduction in transmitter peak output power.

Fixed, point-to-point operation excludes the use of point-to-multipoint systems, Omni-directional applications, and multiple co-located intentional radiators transmitting the same information. The operator of the spread spectrum intentional radiator or, if the equipment is professionally installed, the installer is responsible for ensuring that the system is used exclusively for fixed, point-to-point operations. The instruction manual furnished with the intentional radiator shall contain language in the installation instructions informing the operator and the installer of this responsibility.

Test Procedure: The transmitter was connected to a calibrated spectrum analyzer. The EUT was measured at the low, mid and high channels of each band at the maximum power level.

Test Results: The EUT was compliant with the Peak Power Output limits of §15.247(b).

Test Engineer(s): Lionel Gabrillo

Test Date(s): 03/10/11

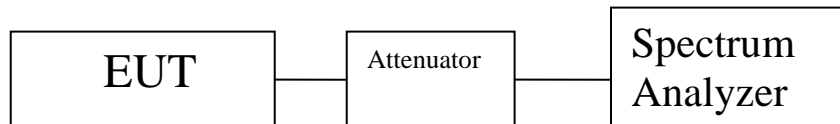

Figure 3. Peak Power Output Test Setup

Peak Power Output Test Results

Peak Output Power						
HT Mode	Frequency (MHz)	Channels	Port 1 dBm	Port 2 dBm	Sum of Ports mW	Sum of Ports dBm
HT5	5728	Low	21.71	20.94	272.42	24.35
	5787	Mid	21.15	19.27	214.84	23.32
	5847	High	20.87	19.49	211.10	23.24
HT8	5730	Low	21.73	20.62	264.28	24.22
	5787	Mid	21.32	20.36	244.16	23.88
	5845	High	21.05	20.62	242.70	23.85
HT10	5731	Low	22.45	21.75	325.42	25.12
	5787	Mid	22.03	21.02	286.06	24.56
	5844	High	21.58	20.16	247.63	23.94
HT20	5735	Low	23.55	22.84	418.77	26.22
	5787	Mid	21.67	20.82	267.67	24.28
	5840	High	20.87	20.35	230.57	23.63
HT30	5740	Low	23.34	22.55	395.66	25.97
	5787	Mid	21.51	20.48	253.27	24.04
	5835	High	20.38	19.62	200.77	23.03
HT40	5747	Low	22.78	21.98	347.43	25.41
	5787	Mid	22.45	21.04	302.85	24.81
	5828	High	21.91	20.59	269.79	24.31

Peak Output Power			
HT Mode	Frequency (MHz)	Channels	Output Power dBm
802.11a 20MHz	5735	Low	24.01
	5787	Mid	22.74
	5840	High	20.82
802.11a 40MHz	5747	Low	22.92
	5787	Mid	22.47
	5828	High	21.51

Table 20. Peak Power Output, Test Results

Electromagnetic Compatibility Criteria for Intentional Radiators

§ 15.247(d) Radiated Spurious Emissions Requirements and Band Edge

Test Requirements: §15.247(d); §15.205: Emissions outside the frequency band.

§15.247(d): In any 100 kHz bandwidth outside the frequency band in which the spread spectrum or digitally modulated intentional radiator is operating, the radio frequency power that is produced by the intentional radiator shall be at least 20 dB below that in the 100 kHz bandwidth within the band that contains the highest level of the desired power, based on either an RF conducted or a radiated measurement. Attenuation below the general limits specified in § 15.209(a) is not required. In addition, radiated emissions which fall in the restricted bands, as defined in § 15.205(a), must also comply with the radiated emission limits specified in § 15.209(a).

§15.205(a): Except as shown in paragraph (d) of this section, only spurious emissions are permitted in any of the frequency bands listed below:

MHz	MHz	MHz	GHz
0.090–0.110-----	16.42–16.423	399.9–410	4.5–5.15
¹ 0.495–0.505-----	16.69475–16.69525	608–614	5.35–5.46
2.1735–2.1905-----	16.80425–16.80475	960–1240	7.25–7.75
4.125–4.128-----	25.5–25.67	1300–1427	8.025–8.5
4.17725–4.17775-----	37.5–38.25	1435–1626.5	9.0–9.2
4.20725–4.20775-----	73–74.6	1645.5–1646.5	9.3–9.5
6.215–6.218-----	74.8–75.2	1660–1710	10.6–12.7
6.26775–6.26825-----	108–121.94	1718.8–1722.2	13.25–13.4
6.31175–6.31225-----	123–138	2200–2300	14.47–14.5
8.291–8.294-----	149.9–150.05	2310–2390	15.35–16.2
8.362–8.366-----	156.52475–156.52525	2483.5–2500	17.7–21.4
8.37625–8.38675-----	156.7–156.9	2655–2900	22.01–23.12
8.41425–8.41475-----	162.0125–167.17	3260–3267	23.6–24.0
12.29–12.293-----	167.72–173.2	3332–3339	31.2–31.8
12.51975–12.52025-----	240–285	3345.8–3358 36.	43–36.5
12.57675–12.57725-----	322–335.4	3600–4400	(²)

Table 21. Restricted Bands of Operation

¹ Until February 1, 1999, this restricted band shall be 0.490 – 0.510 MHz.

² Above 38.6

Test Requirement(s): § 15.209 (a): Except as provided elsewhere in this subpart, the emissions from an intentional radiator shall not exceed the field strength levels specified in Table 22.

Frequency (MHz)	§ 15.209(a), Radiated Emission Limits (dB μ V) @ 3m
30 - 88	40.00
88 - 216	43.50
216 - 960	46.00
Above 960	54.00

Table 22. Radiated Emissions Limits Calculated from FCC Part 15, § 15.209 (a)

Test Procedures: The transmitter was turned on. Measurements were performed of the low, mid and high Channels. The EUT was rotated orthogonally through all three axes. Plots shown are corrected for both antenna correction factor and distance and compared to a 3 m limit line. Only noise floor was measured above 18 GHz.

Average plots 1-7GHz shows peaks over the 54dBuV limit at 5450-5800MHz. The emission was zoomed into to show compliance to the only restricted band (5350-5460MHz) within that range.

Test Results: The EUT was compliant with the Radiated Spurious Emission limits of § 15.247(d).

Test Engineer(s): Lionel Gabrillo

Test Date(s): 03/11/11

Radiated Spurious Emissions, 802.11 20 MHz, Low Channel

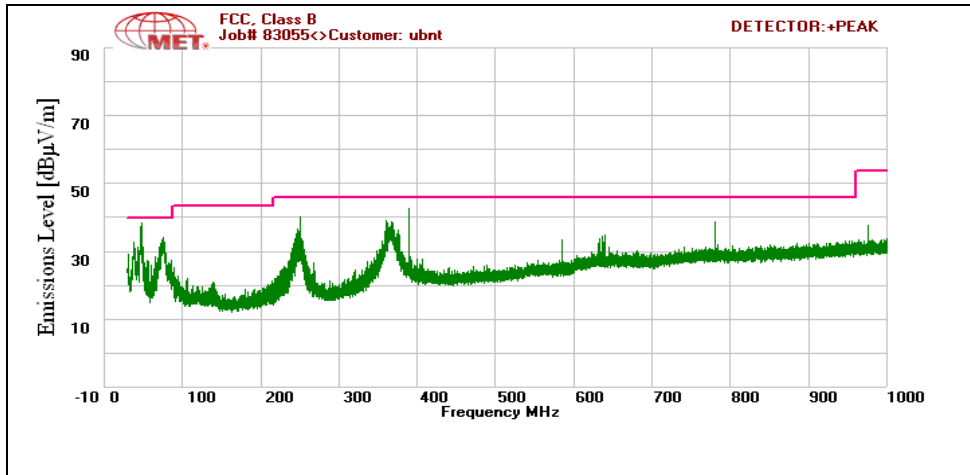

Plot 91. Radiated Spurious Emissions, 802.11a 20 MHz, Low Channel, 30 MHz – 1 GHz

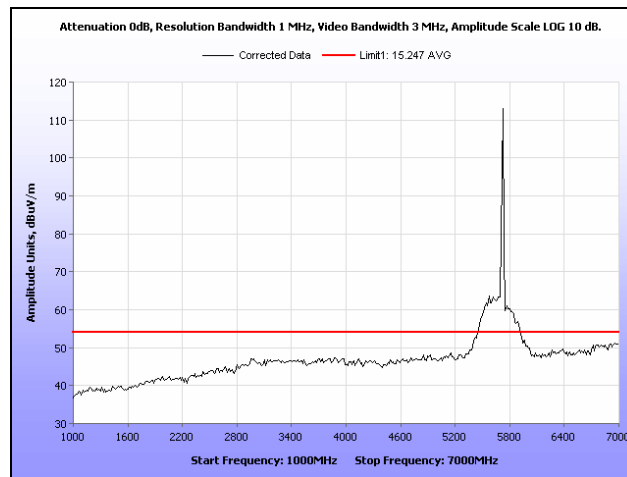

Plot 92. Radiated Spurious Emissions, Low Channel, 802.11a 20MHz, 1 GHz – 7 GHz, Average

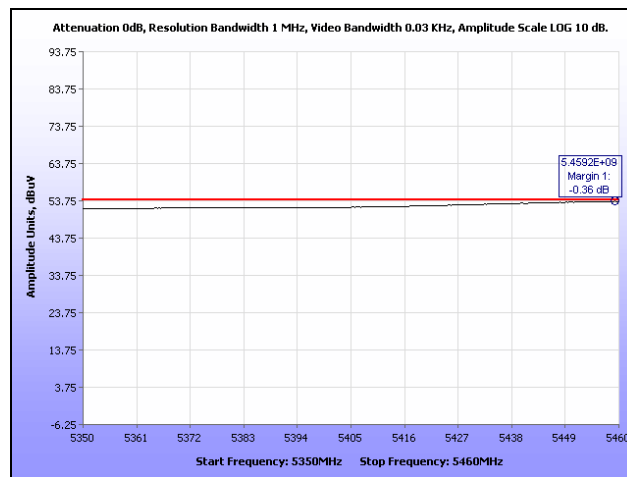

Plot 93. Restricted Band, 802.11a 20 MHz, Low Channel

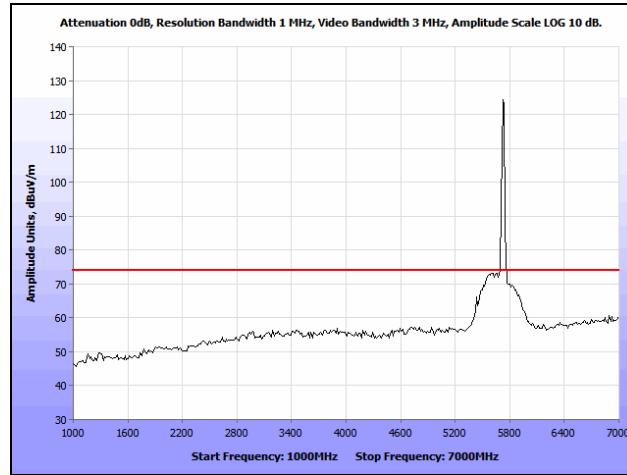

Plot 94. Radiated Spurious Emissions, Low Channel, 802.11a 20MHz, 1 GHz – 7 GHz, Peak

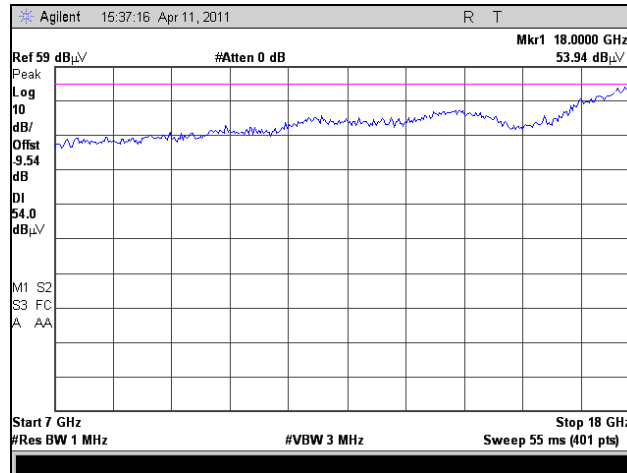

Plot 95 Radiated Spurious Emissions, Low Channel, 802.11a 20 MHz, 7 GHz – 18 GHz

Radiated Spurious Emissions, 802.11 20 MHz, Mid Channel

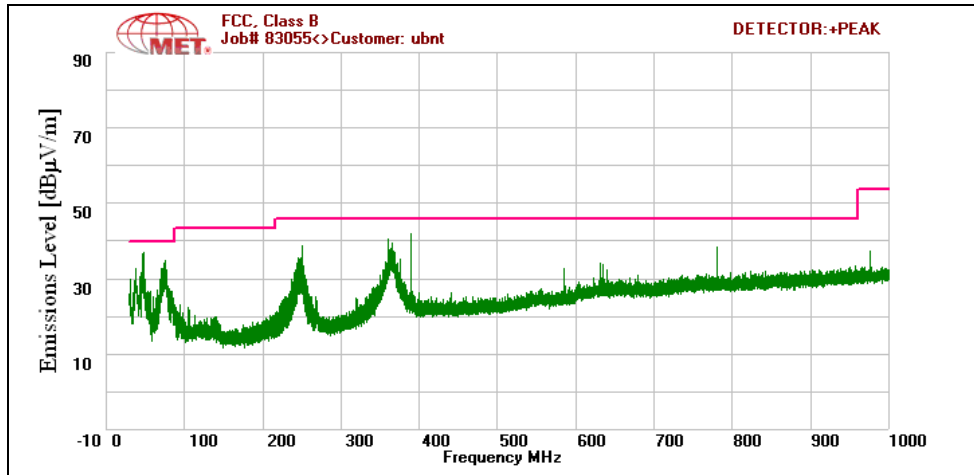

Plot 96. Radiated Spurious Emissions, 802.11a 20 MHz, Mid Channel, 30 MHz – 1 GHz

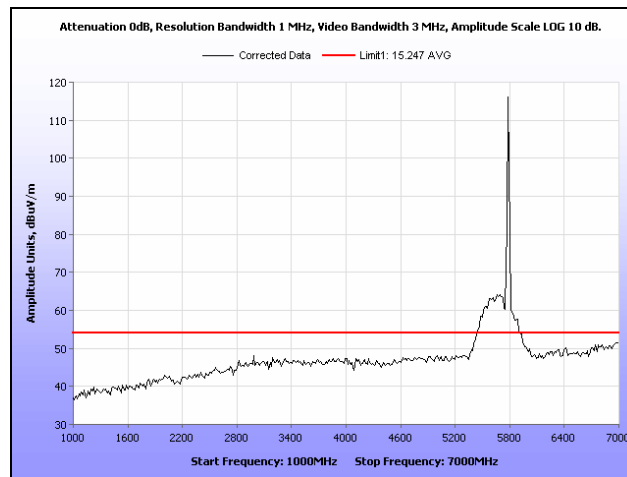

Plot 97. Radiated Spurious Emissions, Mid Channel, 802.11a 20MHz, 1 GHz – 7 GHz, Average

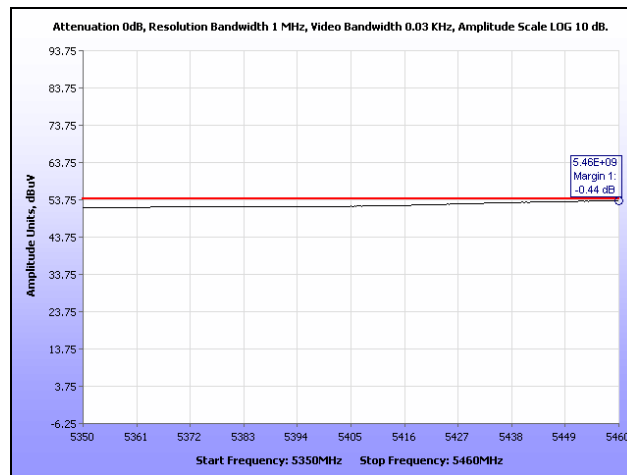

Plot 98. Restricted Band, 802.11a 20 MHz, Mid Channel

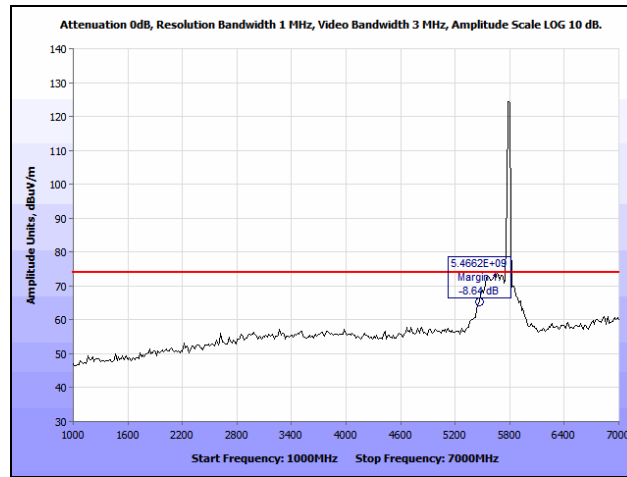

Plot 99. Radiated Spurious Emissions, Mid Channel, 802.11a 20MHz, 1 GHz – 7 GHz, Peak

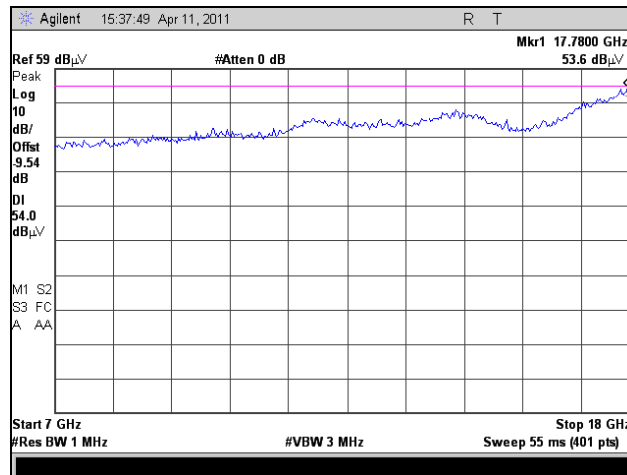

Plot 100. Radiated Spurious Emissions, Mid Channel, 802.11a 20 MHz, 7 GHz – 18 GHz

Radiated Spurious Emissions, 802.11 20 MHz, High Channel

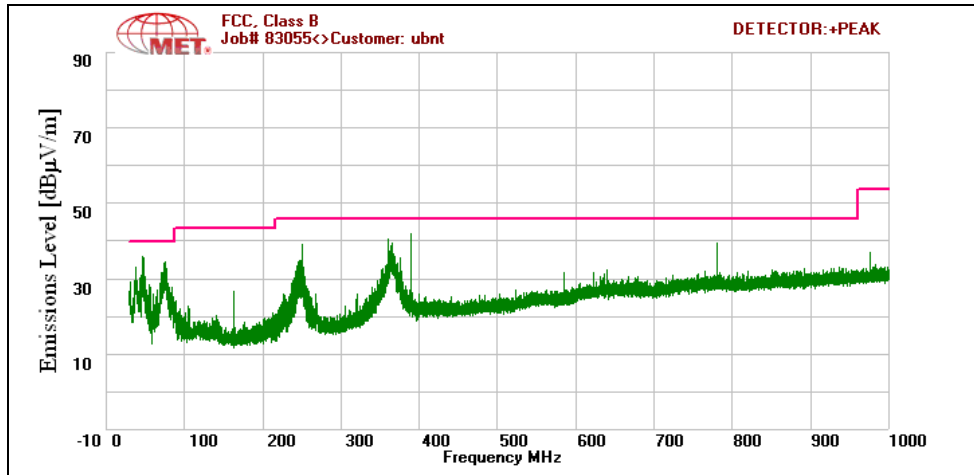

Plot 101. Radiated Spurious Emissions, 802.11a 20 MHz, High Channel, 30 MHz – 1 GHz

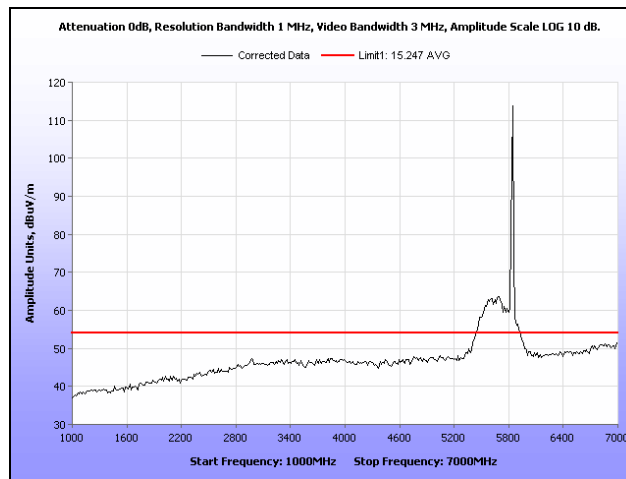

Plot 102. Radiated Spurious Emissions, High Channel, 802.11a 20MHz, 1 GHz – 7 GHz, Average

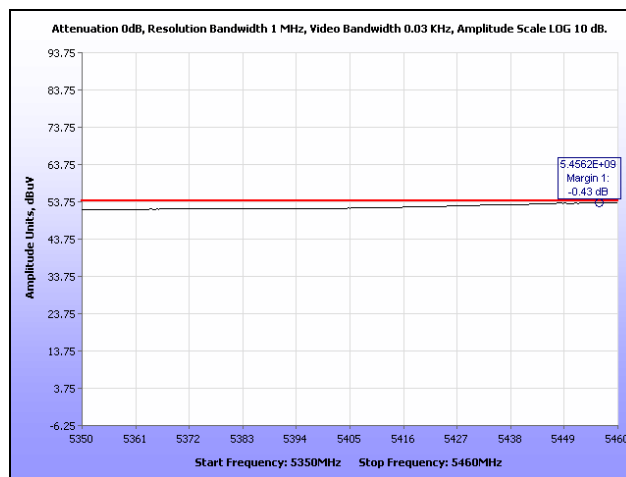

Plot 103. Restricted Band, 802.11a 20 MHz, High Channel

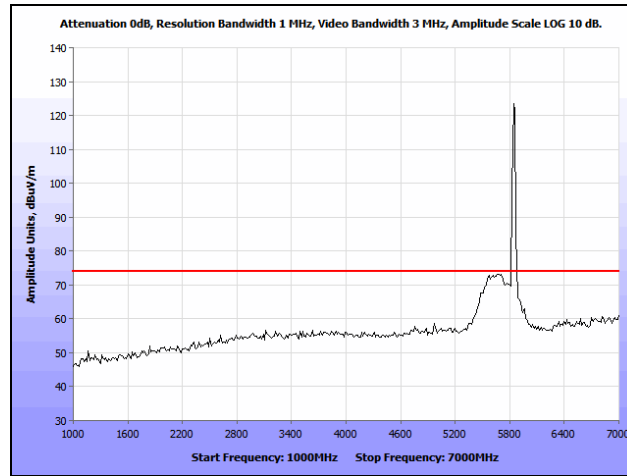

Plot 104. Radiated Spurious Emissions, High Channel, 802.11a 20MHz, 1 GHz – 7 GHz, Peak

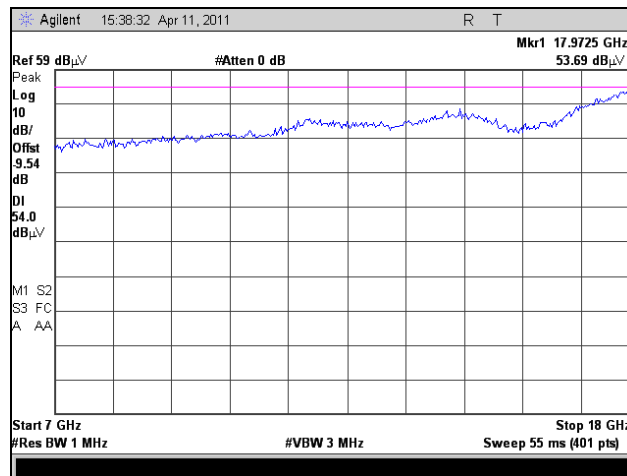

Plot 105. Radiated Spurious Emissions, High Channel, 802.11a 20 MHz, 7 GHz – 18 GHz

Radiated Spurious Emissions, 802.11a 40 MHz, Low Channel

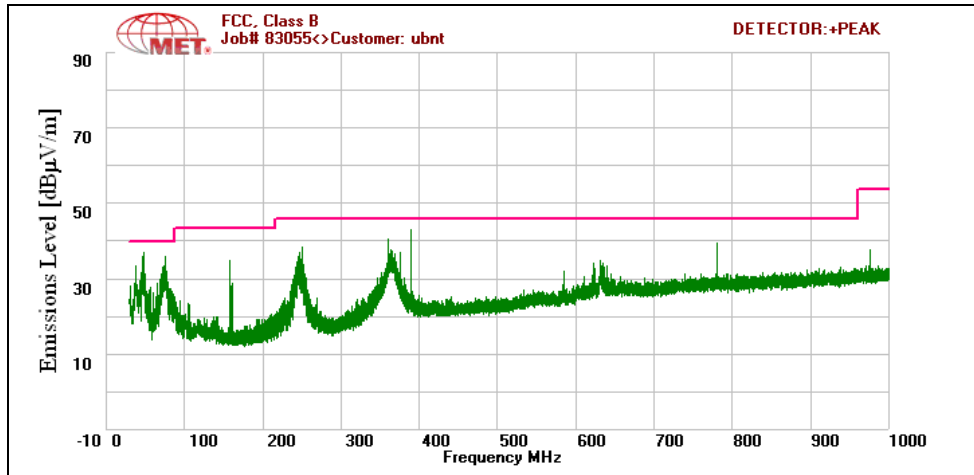

Plot 106. Radiated Spurious Emissions, 802.11a 40 MHz, Low Channel, 30 MHz – 1 GHz

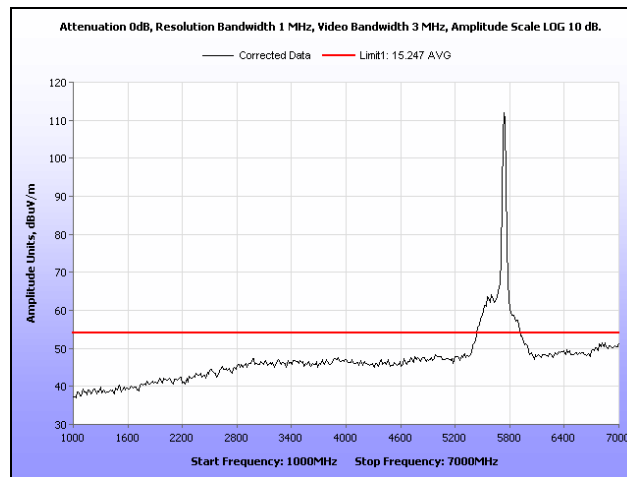

Plot 107. Radiated Spurious Emissions, Low Channel, 802.11a 40MHz, 1 GHz – 7 GHz, Average

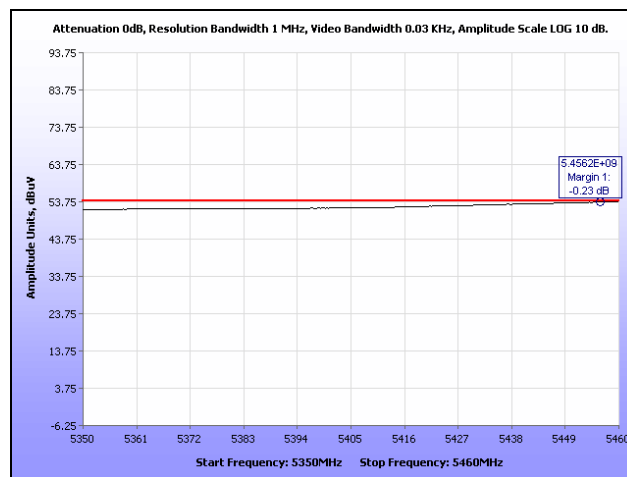

Plot 108. Restricted Band, 802.11a 40 MHz, Low Channel

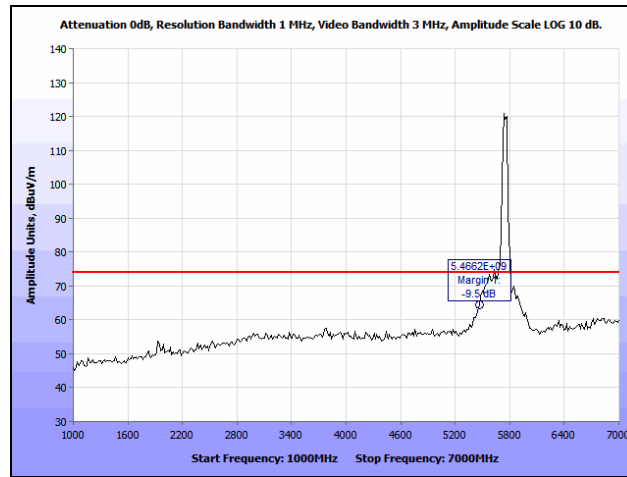

Plot 109. Radiated Spurious Emissions, Low Channel, 802.11a 40MHz, 1 GHz – 7 GHz, Peak

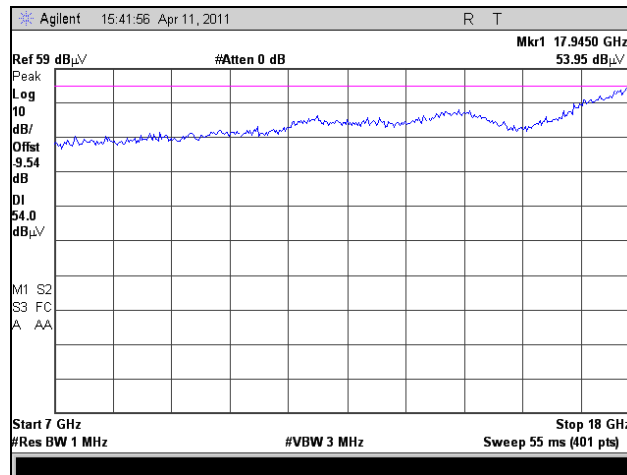

Plot 110. Radiated Spurious Emissions, Low Channel, 802.11a 40 MHz, 7 GHz – 18 GHz

Radiated Spurious Emissions, 802.11a 40 MHz, Mid Channel

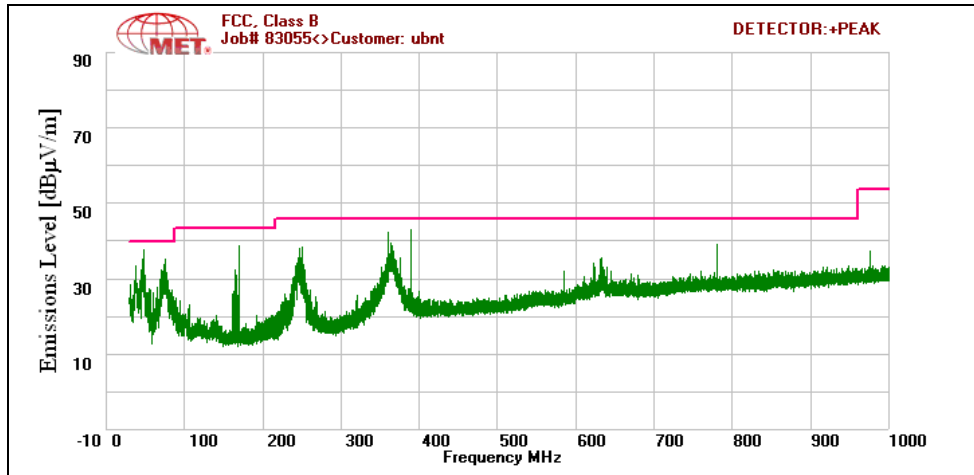

Plot 111. Radiated Spurious Emissions, 802.11a 40 MHz, Mid Channel, 30 MHz – 1 GHz

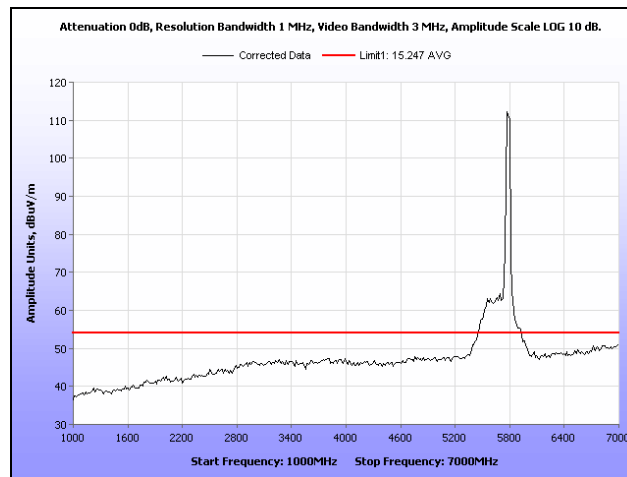

Plot 112. Radiated Spurious Emissions, Mid Channel, 802.11a 40MHz, 1 GHz – 7 GHz, Average

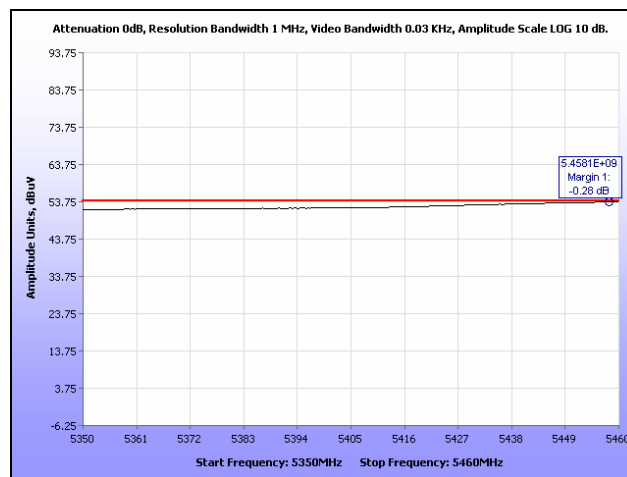

Plot 113. Restricted Band, 802.11a 40 MHz, Mid Channel

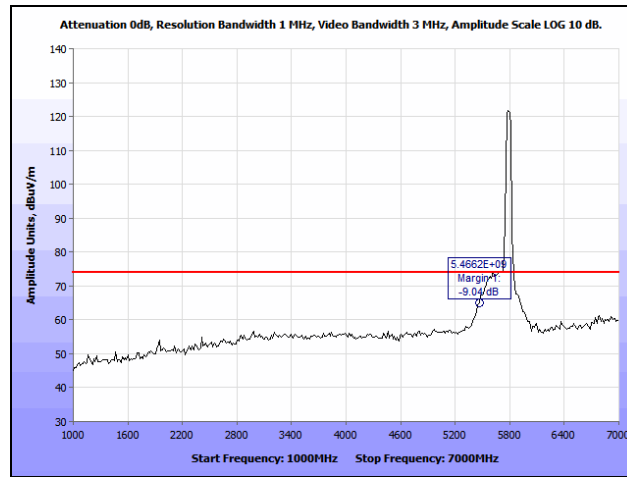

Plot 114. Radiated Spurious Emissions, Mid Channel, 802.11a 40MHz, 1 GHz – 7 GHz, Peak

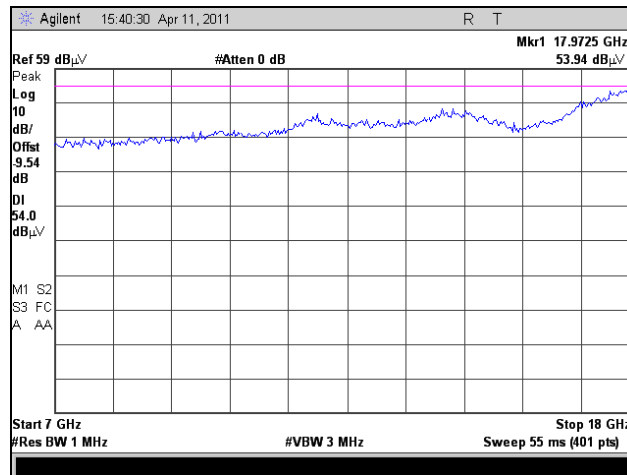

Plot 115. Radiated Spurious Emissions, Mid Channel, 802.11a 40 MHz, 7 GHz – 18 GHz

Radiated Spurious Emissions, 802.11a 40 MHz, High Channel

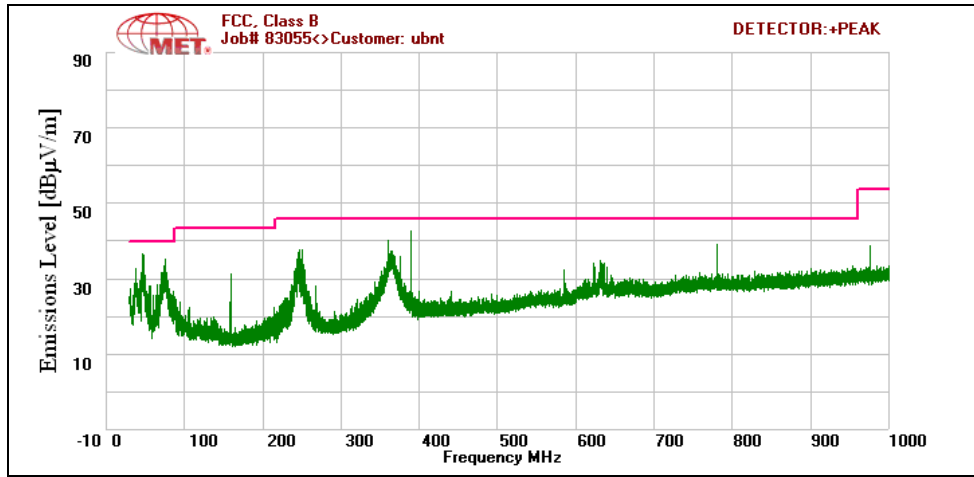

Plot 116. Radiated Spurious Emissions, 802.11a 40 MHz, High Channel, 30 MHz – 1 GHz

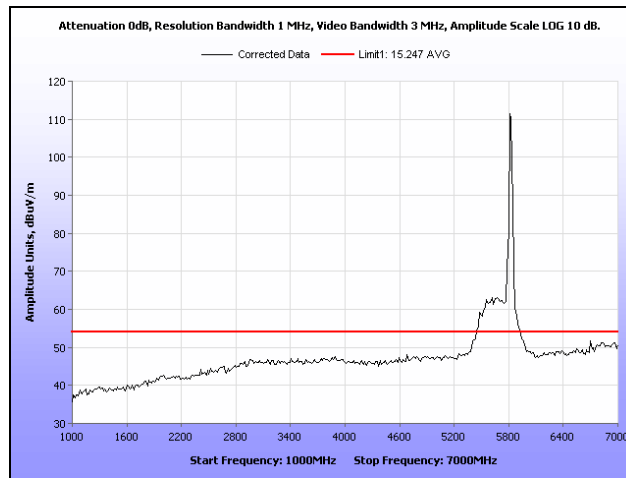

Plot 117. Radiated Spurious Emissions, High Channel, 802.11a 40MHz, 1 GHz – 7 GHz, Average

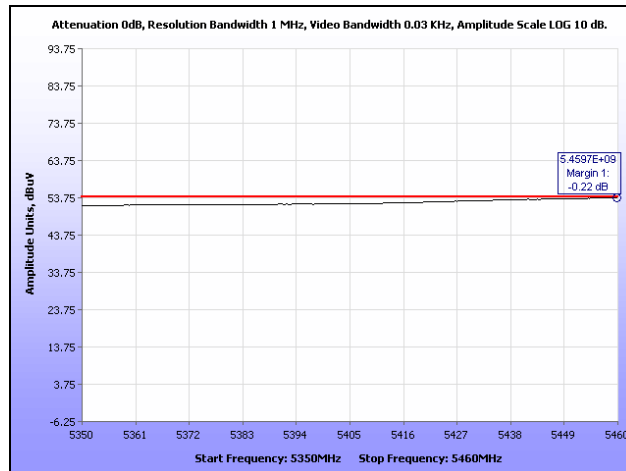

Plot 118. Restricted Band, 802.11a 40 MHz, High Channel

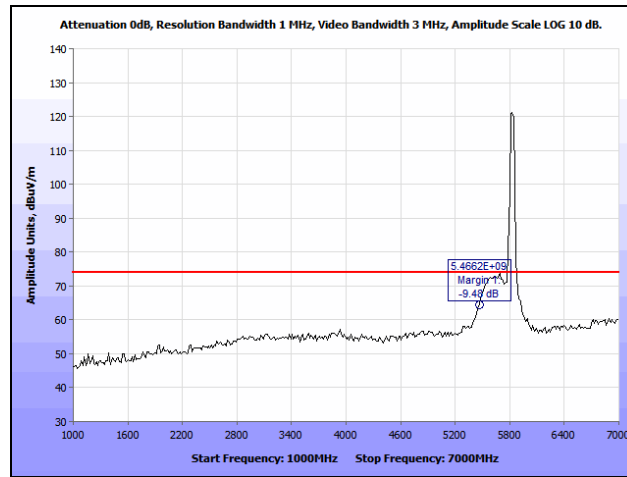

Plot 119. Radiated Spurious Emissions, High Channel, 802.11a 40MHz, 1 GHz – 7 GHz, Peak

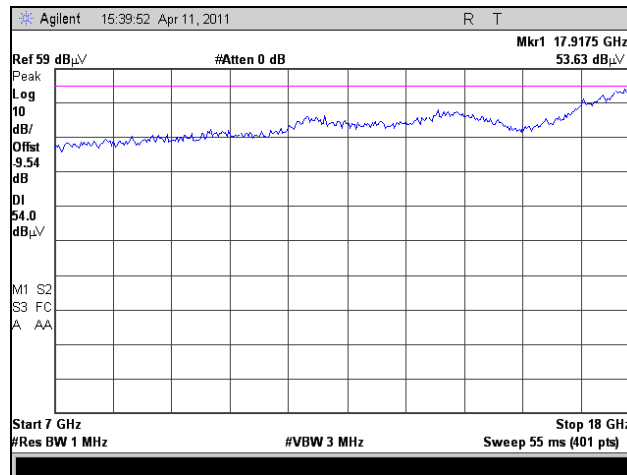

Plot 120. Radiated Spurious Emissions, High Channel, 802.11a 40 MHz, 7 GHz – 18 GHz

Radiated Spurious Emissions, HT5, Low Channel

Frequency (MHz)	Antenna Polarity	EUT Azimuth (Degrees)	Antenna Height (cm)	Uncorrected Amplitude (dBuV)	ACF (dB/m)	Pre Amp Gain (dB)	CBL (dB)	DCF (dB)	Corrected Amplitude (dBuV)	Limit (dBuV)	Margin (dB)
77.6	V	213.6	139.7	59.78	6.72	40	1.414	10.46	38.374	40	-1.626
56	V	46.5	156.4	58.12	6.8	40	1.174	10.46	36.554	40	-3.446

Table 23. Radiated Spurious Emissions, Test Results, HT5, Low Channel

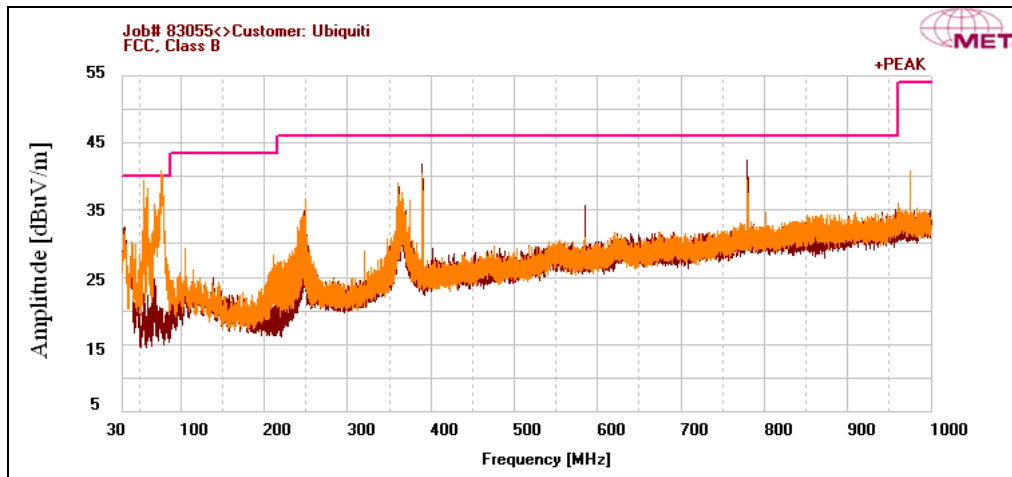

Plot 121. Radiated Spurious Emissions, HT5, Low Channel, 30 MHz – 1 GHz

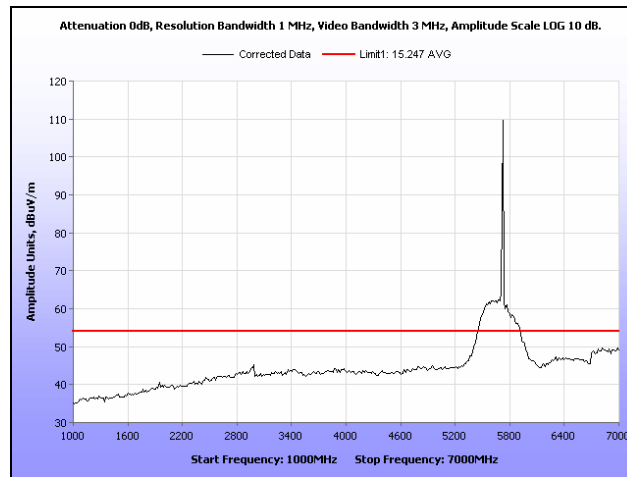

Plot 122. Radiated Spurious Emissions, HT5, Low Channel, 1 GHz – 7 GHz, Average

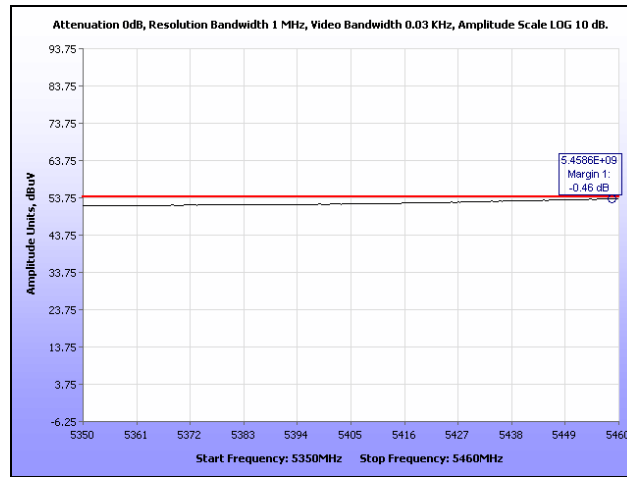

Plot 123. Restricted Band, HT5, Low Channel

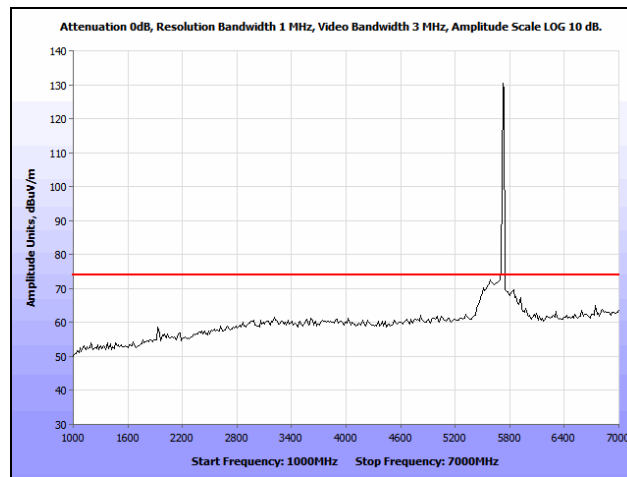

Plot 124. Radiated Spurious Emissions, HT5, Low Channel, 1 GHz – 7 GHz, Peak

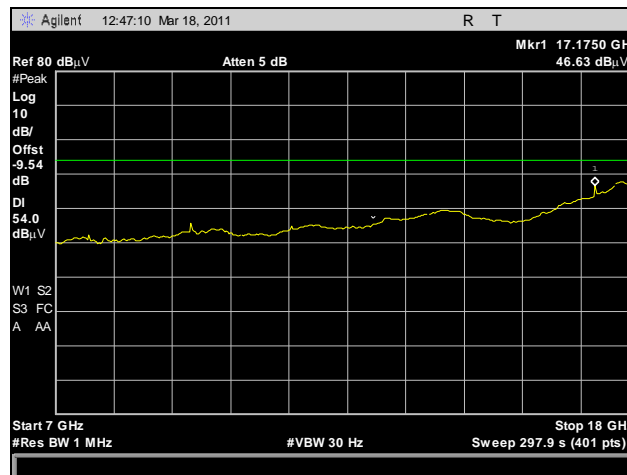

Plot 125. Radiated Spurious Emissions, HT5, Low Channel, 7 GHz – 18 GHz, Average

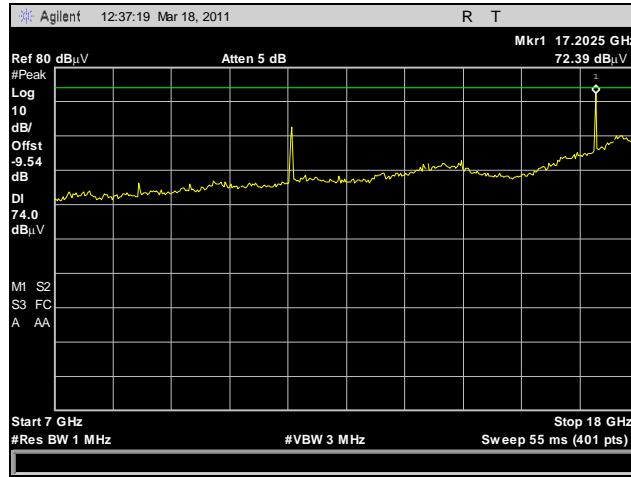

Plot 126. Radiated Spurious Emissions, HT5, Low Channel, 7 GHz – 18 GHz, Peak

Radiated Spurious Emissions, HT5, Mid Channel

Frequency (MHz)	Antenna Polarity	EUT Azimuth (Degrees)	Antenna Height (cm)	Uncorrected Amplitude (dBuV)	ACF (dB/m)	Pre Amp Gain (dB)	CBL (dB)	DCF (dB)	Corrected Amplitude (dBuV)	Limit (dBuV)	Margin (dB)
76.92	V	77.3	170.0	60.76	6.576	40	1.412	10.46	39.208	40	-0.792

Table 24. Radiated Spurious Emissions, Test Results, HT5, Mid Channel

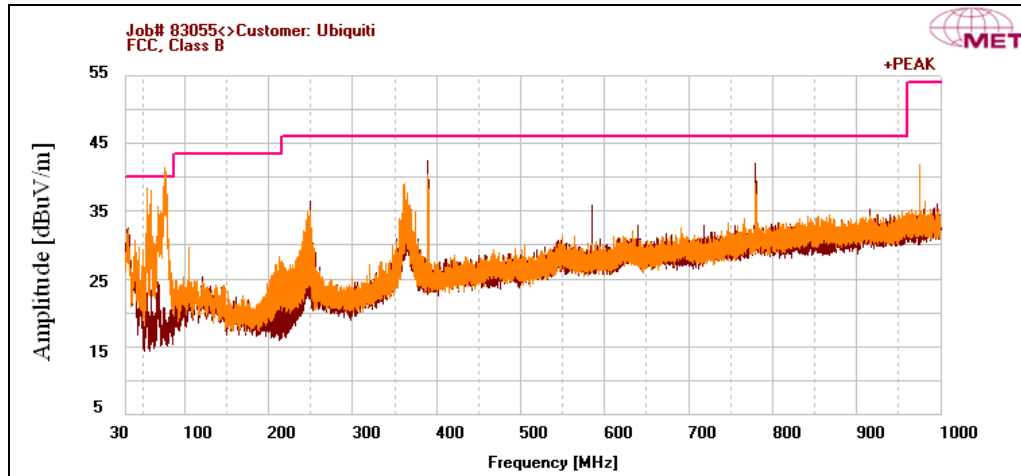

Plot 127. Radiated Spurious Emissions, HT5, Mid Channel, 30 MHz – 1 GHz

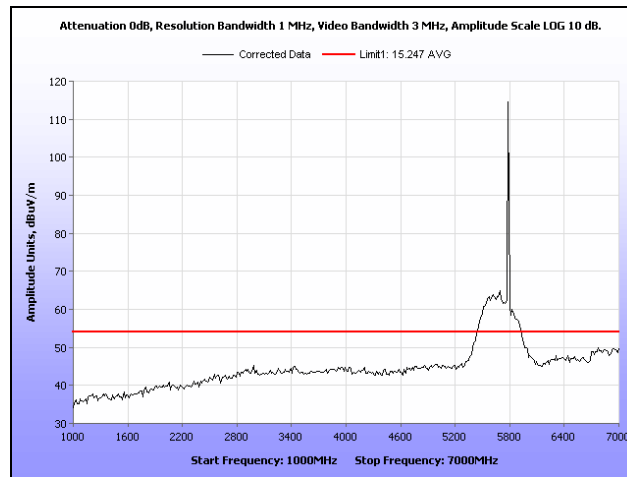

Plot 128. Radiated Spurious Emissions, HT5, Mid Channel, 1 GHz – 7 GHz, Average

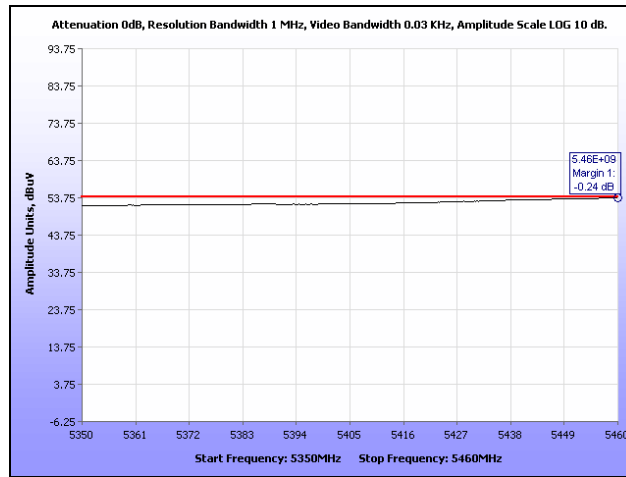

Plot 129. Restricted Band, HT5, Mid Channel

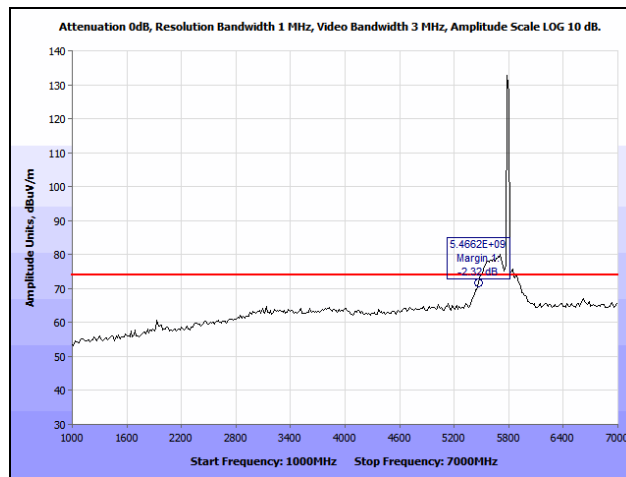

Plot 130. Radiated Spurious Emissions, HT5, Mid Channel, 1 GHz – 7 GHz, Peak

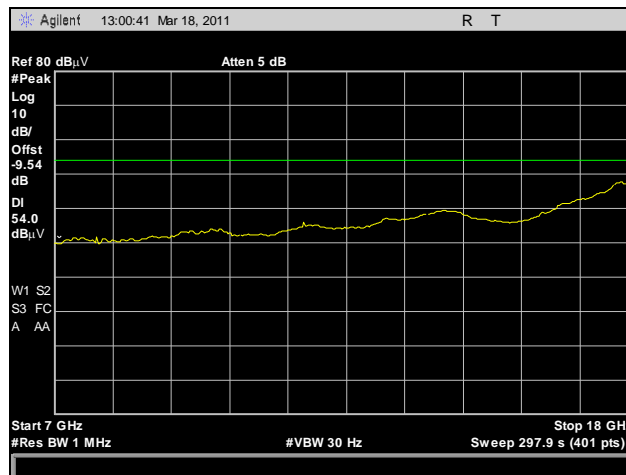

Plot 131. Radiated Spurious Emissions, HT5, Mid Channel, 7 GHz – 18 GHz, Average

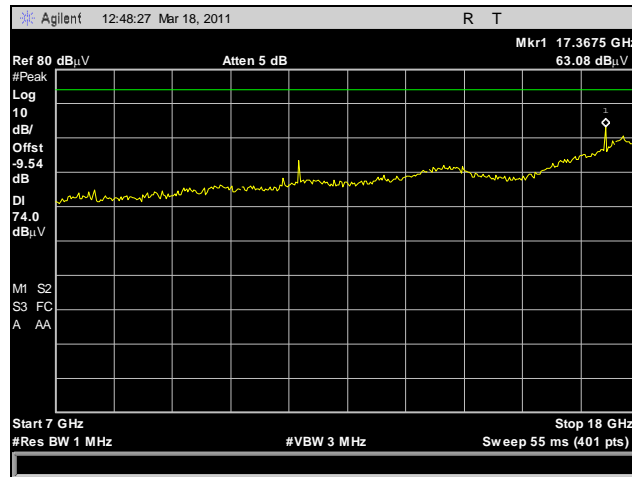

Plot 132. Radiated Spurious Emissions, HT5, Mid Channel, 7 GHz – 18 GHz, Peak

Radiated Spurious Emissions, HT5, High Channel

Frequency (MHz)	Antenna Polarity	EUT Azimuth (Degrees)	Antenna Height (cm)	Uncorrected Amplitude (dBuV)	ACF (dB/m)	Pre Amp Gain (dB)	CBL (dB)	DCF (dB)	Corrected Amplitude (dBuV)	Limit (dBuV)	Margin (dB)
76.92	V	107.1	168.4	60.56	6.576	40	1.412	10.46	39.008	40	-0.992

Table 25. Radiated Spurious Emissions, Test Results, HT5, High Channel

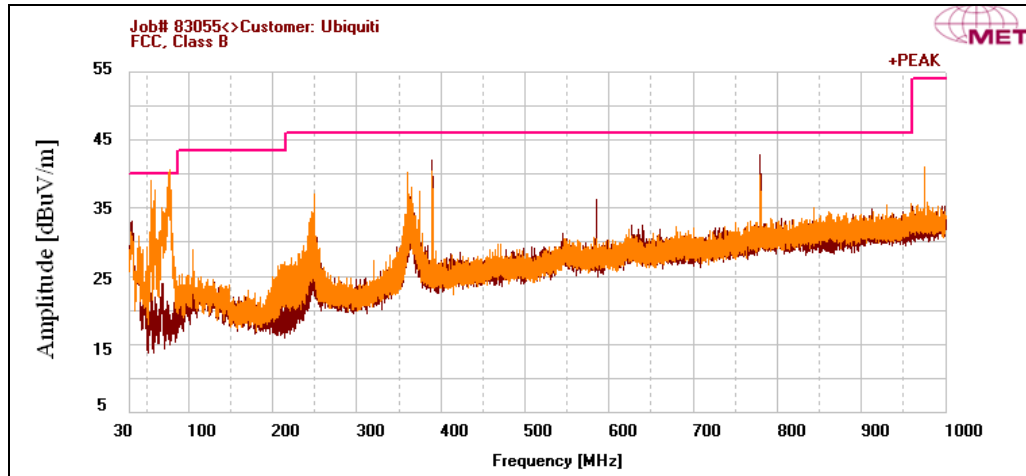

Plot 133. Radiated Spurious Emissions, HT5, High Channel, 30 MHz – 1 GHz

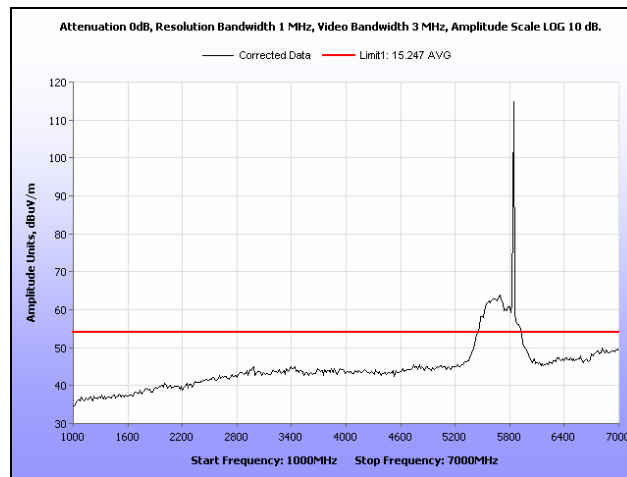

Plot 134. Radiated Spurious Emissions, HT5, High Channel, 1 GHz – 7 GHz, Average

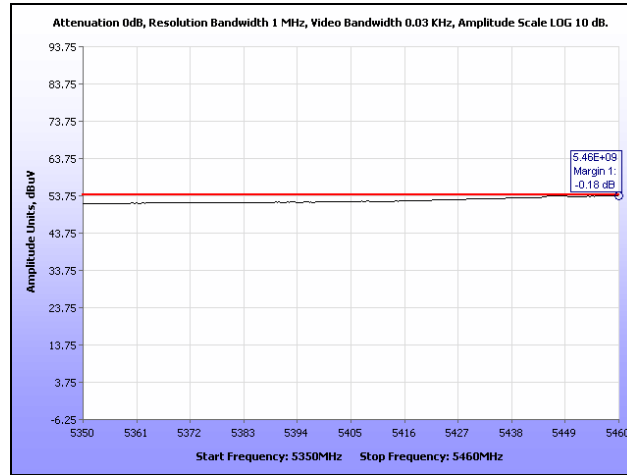

Plot 135. Restricted Band, HT5, High Channel

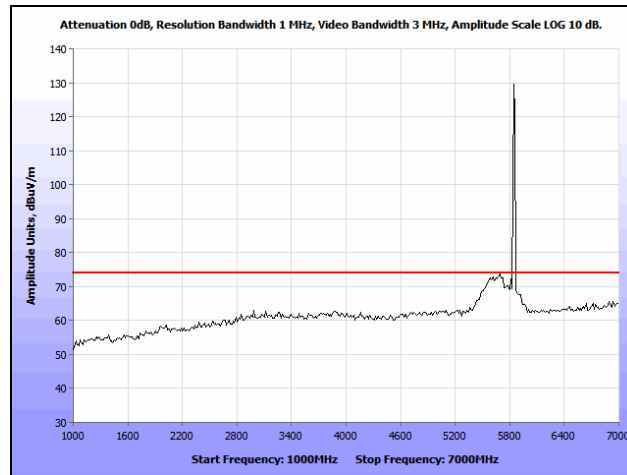

Plot 136. Radiated Spurious Emissions, HT5, High Channel, 1 GHz – 7 GHz, Peak

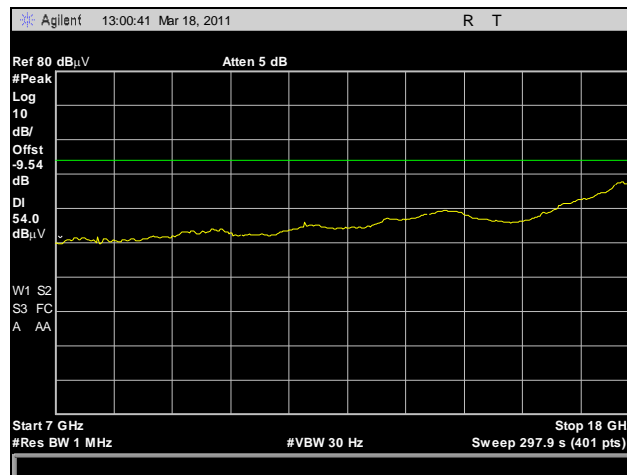

Plot 137. Radiated Spurious Emissions, HT5, High Channel, 7 GHz – 18 GHz, Average

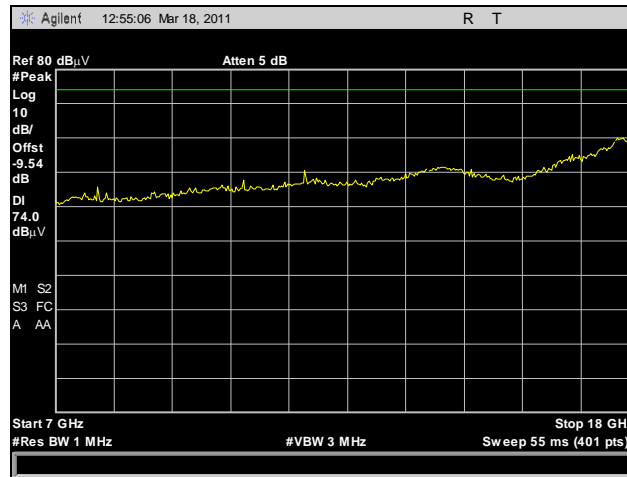

Plot 138. Radiated Spurious Emissions, HT5, High Channel, 7 GHz – 18 GHz, Peak

Radiated Spurious Emissions, HT8, Low Channel

Frequency (MHz)	Antenna Polarity	EUT Azimuth (Degrees)	Antenna Height (cm)	Uncorrected Amplitude (dBuV)	ACF (dB/m)	Pre Amp Gain (dB)	CBL (dB)	DCF (dB)	Corrected Amplitude (dBuV)	Limit (dBuV)	Margin (dB)
77.3	V	216.5	156.4	60.06	6.66	40	1.413	10.46	38.593	40	-1.407

Table 26. Radiated Spurious Emissions, Test Results, HT8, Low Channel

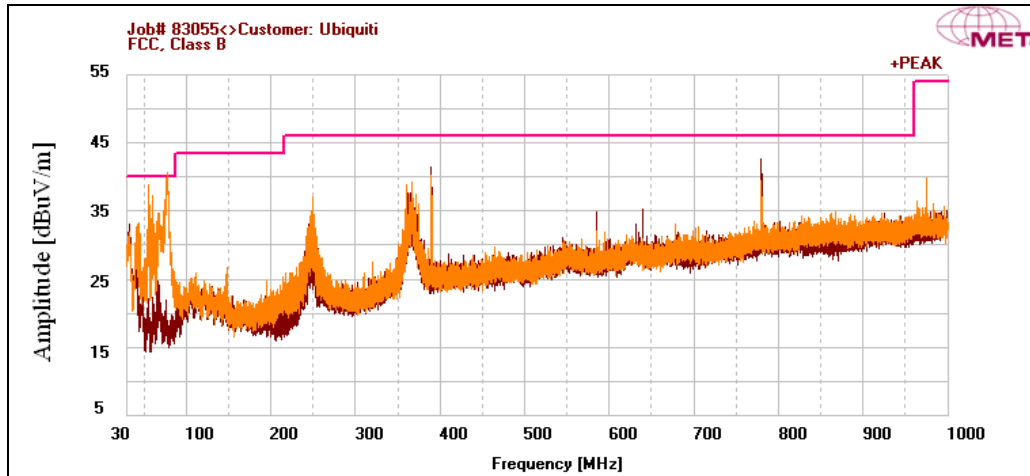

Plot 139. Radiated Spurious Emissions, HT8, Low Channel, 30 MHz – 1 GHz

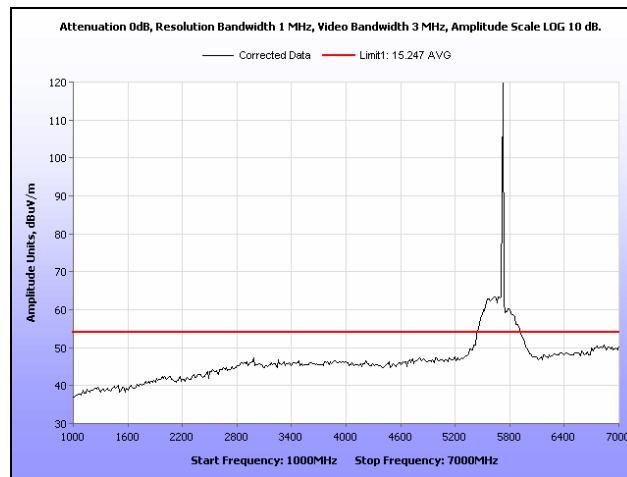

Plot 140. Radiated Spurious Emissions, HT8, Low Channel, 1 GHz – 7 GHz, Average

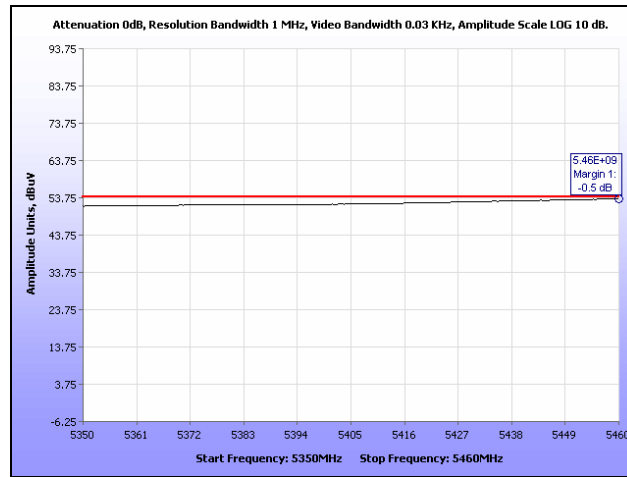

Plot 141. Restricted Band, HT8, Low Channel

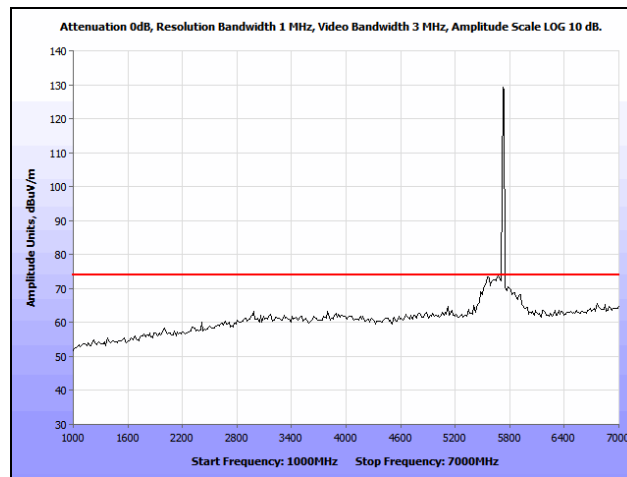

Plot 142. Radiated Spurious Emissions, HT8, Low Channel, 1 GHz – 7 GHz, Peak

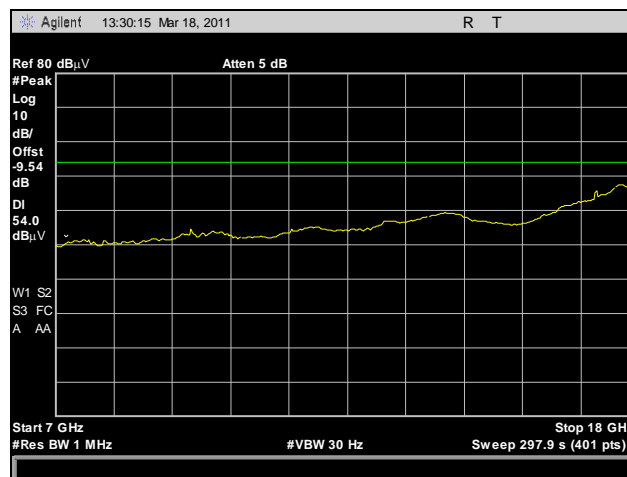

Plot 143. Radiated Spurious Emissions, HT8, Low Channel, 7 GHz – 18 GHz, Average

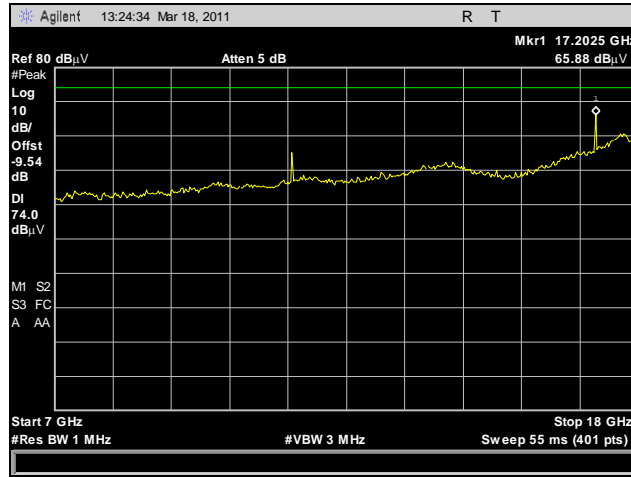

Plot 144. Radiated Spurious Emissions, HT8, Low Channel, 7 GHz – 18 GHz, Peak

Radiated Spurious Emissions, HT8, Mid Channel

Frequency (MHz)	Antenna Polarity	EUT Azimuth (Degrees)	Antenna Height (cm)	Uncorrected Amplitude (dBuV)	ACF (dB/m)	Pre Amp Gain (dB)	CBL (dB)	DCF (dB)	Corrected Amplitude (dBuV)	Limit (dBuV)	Margin (dB)
76.97	V	212.4	148.9	59.86	6.591	40	1.412	10.46	38.323	40	-1.677

Table 27. Radiated Spurious Emissions, Test Results, HT8, Mid Channel

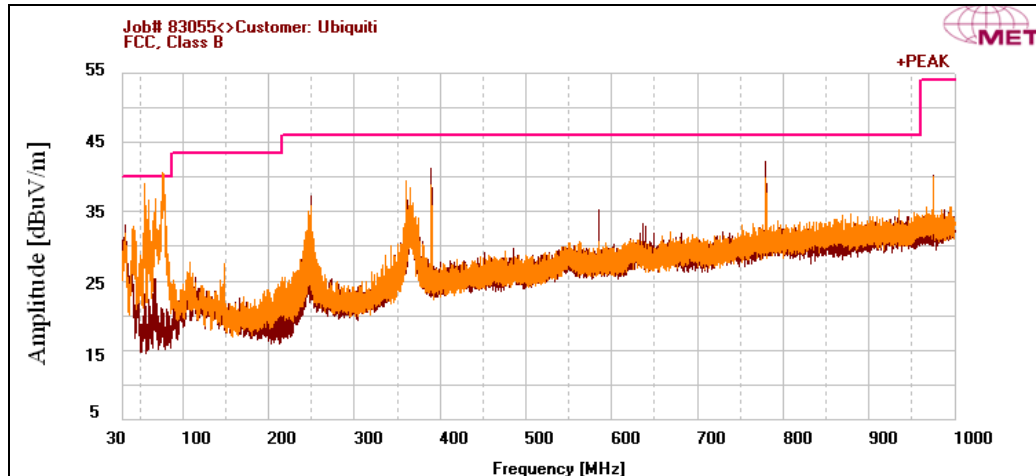

Plot 145. Radiated Spurious Emissions, HT8, Mid Channel, 30 MHz – 1 GHz

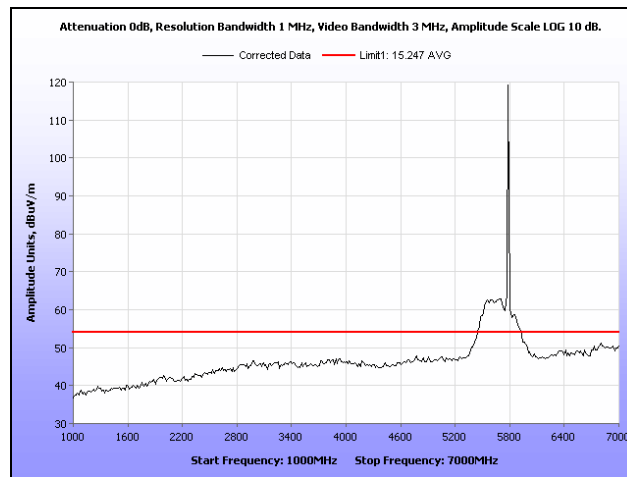

Plot 146. Radiated Spurious Emissions, HT8, Mid Channel, 1 GHz – 7 GHz, Average

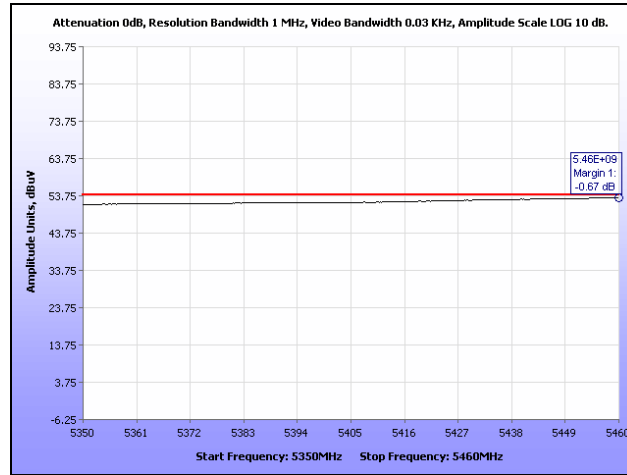

Plot 147. Restricted Band, HT8, Mid Channel

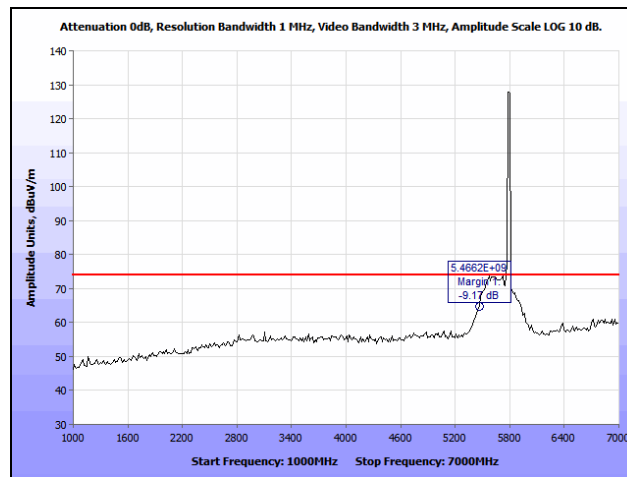

Plot 148. Radiated Spurious Emissions, HT8, Mid Channel, 1 GHz – 7 GHz, Peak

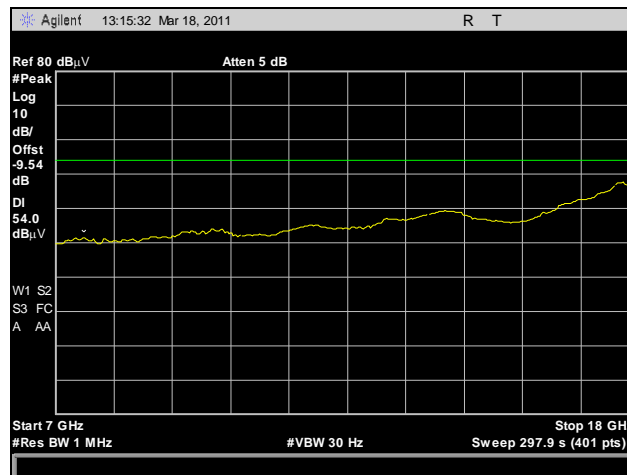

Plot 149. Radiated Spurious Emissions, HT8, Mid Channel, 7 GHz – 18 GHz, Average

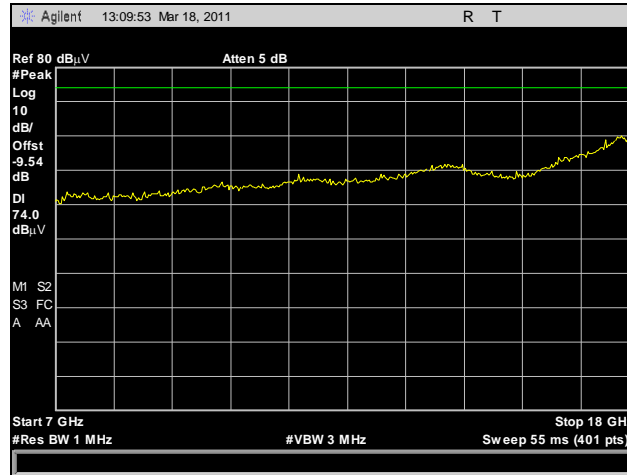

Plot 150. Radiated Spurious Emissions, HT8, Mid Channel, 7 GHz – 18 GHz, Peak

Radiated Spurious Emissions, HT8, High Channel

Frequency (MHz)	Antenna Polarity	EUT Azimuth (Degrees)	Antenna Height (cm)	Uncorrected Amplitude (dBuV)	ACF (dB/m)	Pre Amp Gain (dB)	CBL (dB)	DCF (dB)	Corrected Amplitude (dBuV)	Limit (dBuV)	Margin (dB)
77.2	V	217.8	165.7	59.78	6.64	40	1.413	10.46	38.293	40	-1.707

Table 28. Radiated Spurious Emissions, Test Results, HT8, High Channel

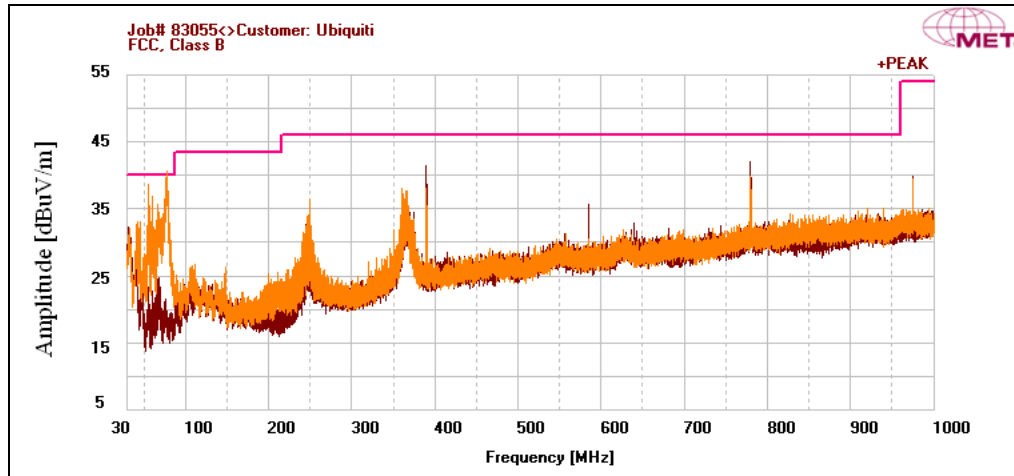

Plot 151. Radiated Spurious Emissions, HT8, High Channel, 30 MHz – 1 GHz

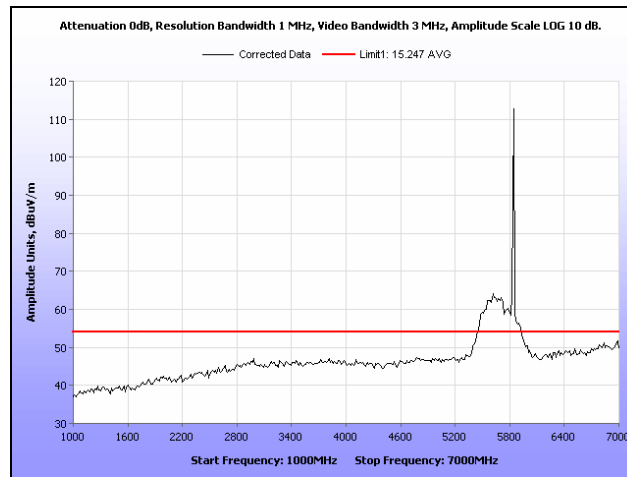

Plot 152. Radiated Spurious Emissions, HT8, High Channel, 1 GHz – 7 GHz, Average

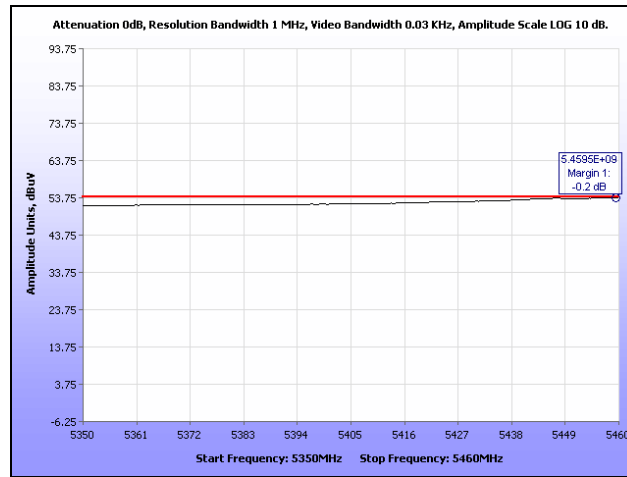

Plot 153. Restricted Band, HT8, High Channel

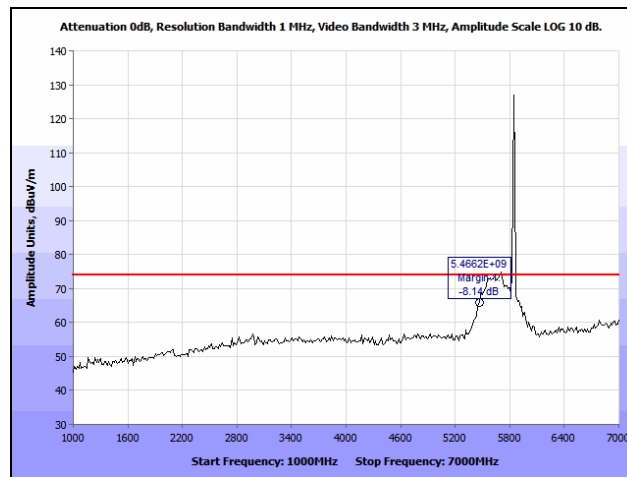

Plot 154. Radiated Spurious Emissions, HT8, High Channel, 1 GHz – 7 GHz, Peak

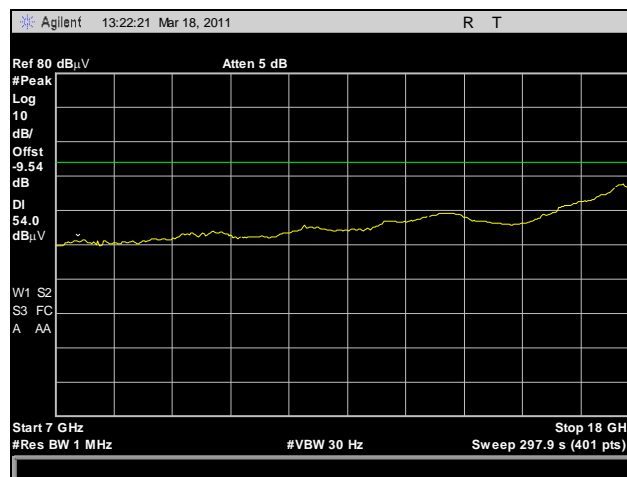

Plot 155. Radiated Spurious Emissions, HT8, High Channel, 7 GHz – 18 GHz, Average

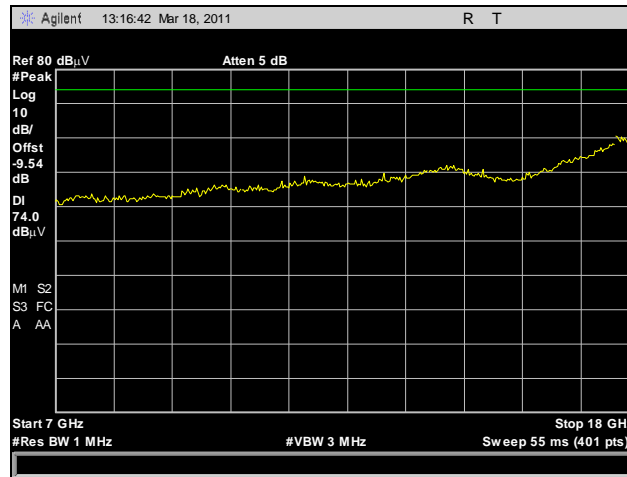

Plot 156. Radiated Spurious Emissions, HT8, High Channel, 7 GHz – 18 GHz, Peak

Radiated Spurious Emissions, HT10, Low Channel

Frequency (MHz)	Antenna Polarity	EUT Azimuth (Degrees)	Antenna Height (cm)	Uncorrected Amplitude (dBuV)	ACF (dB/m)	Pre Amp Gain (dB)	CBL (dB)	DCF (dB)	Corrected Amplitude (dBuV)	Limit (dBuV)	Margin (dB)
77.263	V	63.9	157.2	60.26	6.653	40	1.413	10.46	38.786	40	-1.214

Table 29. Radiated Spurious Emissions, Test Results, HT10, Low Channel

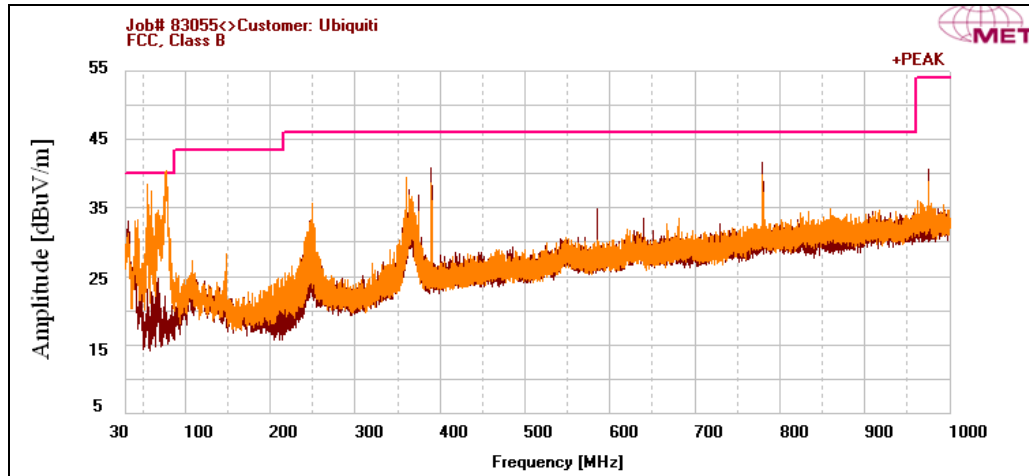

Plot 157. Radiated Spurious Emissions, HT10, Low Channel, 30 MHz – 1 GHz

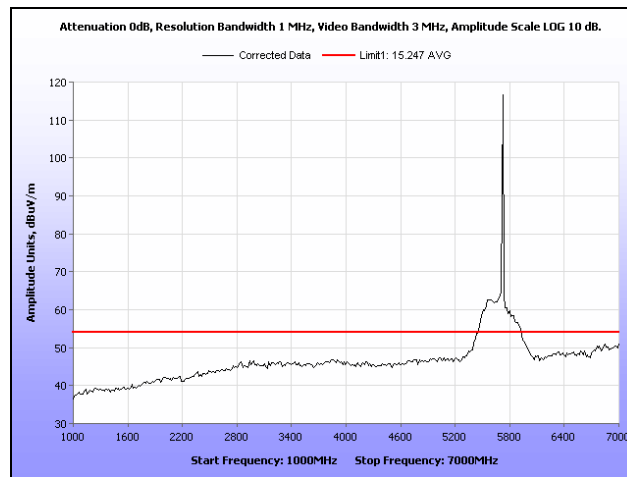

Plot 158. Radiated Spurious Emissions, HT10, Low Channel, 1 GHz – 7 GHz, Average

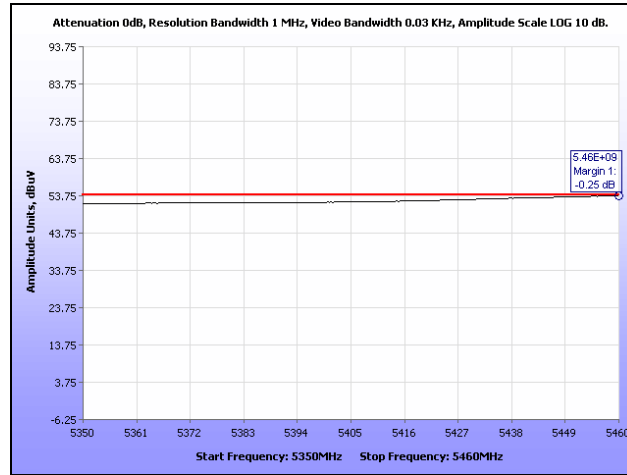

Plot 159. Restricted Band, HT10, Low Channel

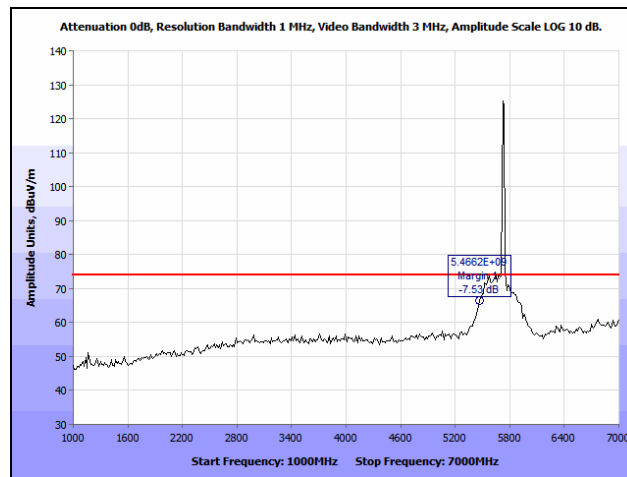

Plot 160. Radiated Spurious Emissions, HT10, Low Channel, 1 GHz – 7 GHz, Peak

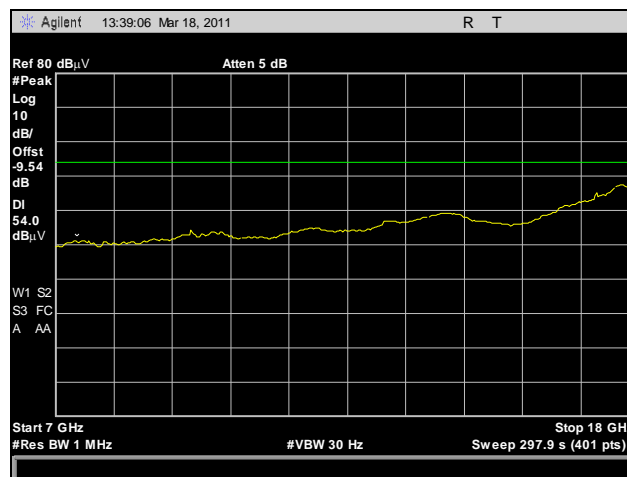

Plot 161. Radiated Spurious Emissions, HT10, Low Channel, 7 GHz – 18 GHz, Average

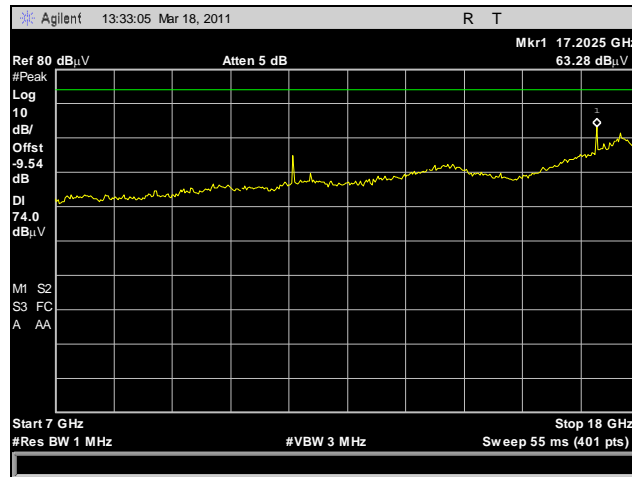

Plot 162. Radiated Spurious Emissions, HT10, Low Channel, 7 GHz – 18 GHz, Peak

Radiated Spurious Emissions, HT10, Mid Channel

Frequency (MHz)	Antenna Polarity	EUT Azimuth (Degrees)	Antenna Height (cm)	Uncorrected Amplitude (dBuV)	ACF (dB/m)	Pre Amp Gain (dB)	CBL (dB)	DCF (dB)	Corrected Amplitude (dBuV)	Limit (dBuV)	Margin (dB)
76.86	V	75.4	148.7	60.69	6.558	40	1.411	10.46	39.119	40	-0.881

Table 30. Radiated Spurious Emissions, Test Results, HT10, Mid Channel

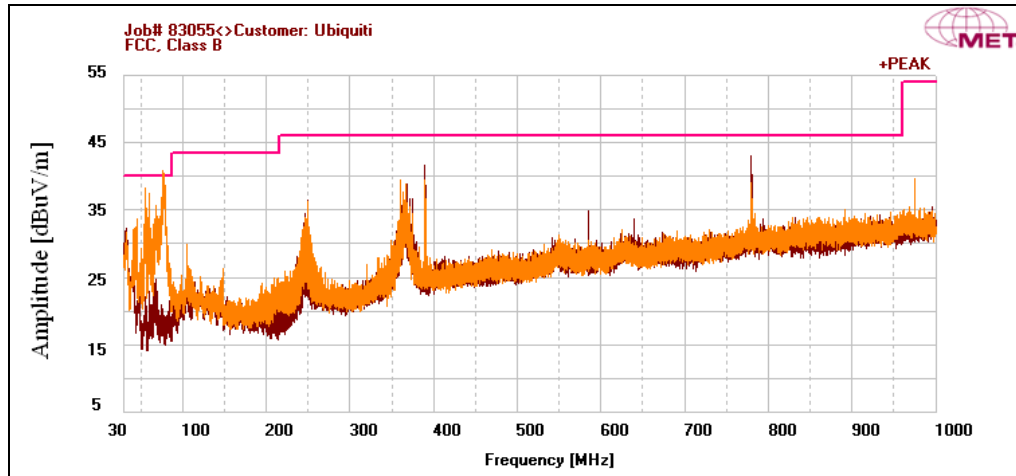

Plot 163. Radiated Spurious Emissions, HT10, Mid Channel, 30 MHz – 1 GHz

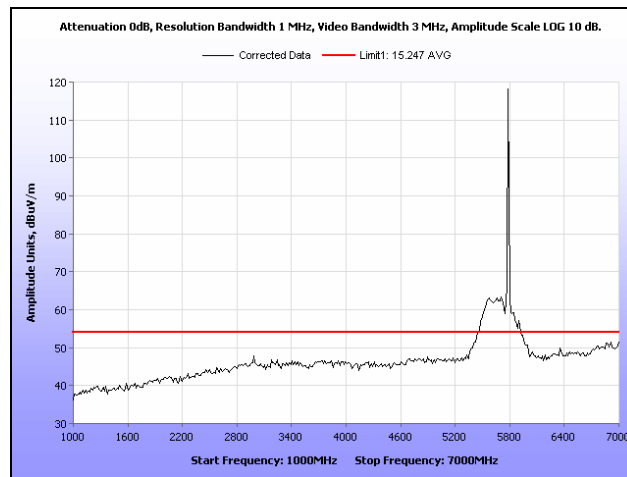

Plot 164. Radiated Spurious Emissions, HT10, Mid Channel, 1 GHz – 7 GHz, Average

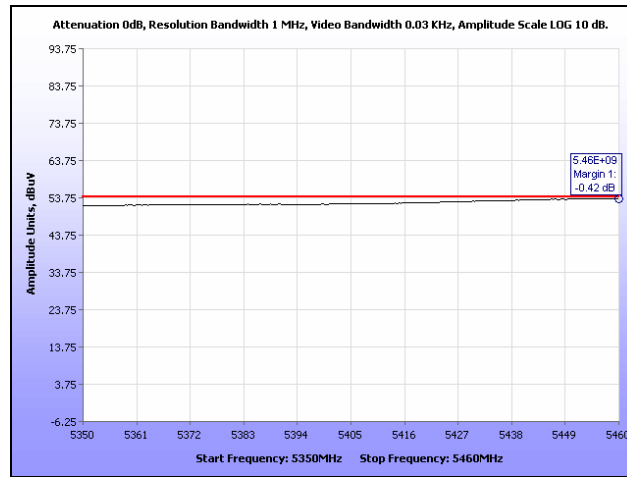

Plot 165. Restricted Band, HT10, Mid Channel

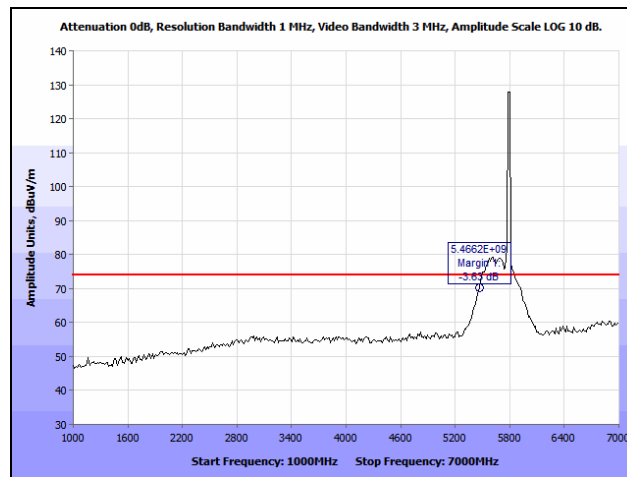

Plot 166. Radiated Spurious Emissions, HT10, Mid Channel, 1 GHz – 7 GHz, Peak

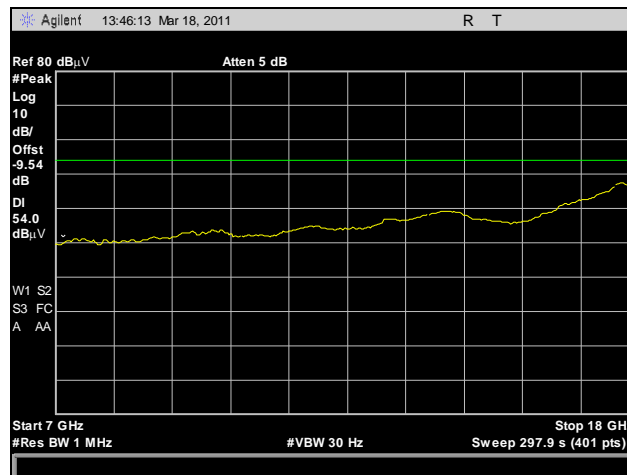

Plot 167. Radiated Spurious Emissions, HT10, Mid Channel, 7 GHz – 18 GHz, Average

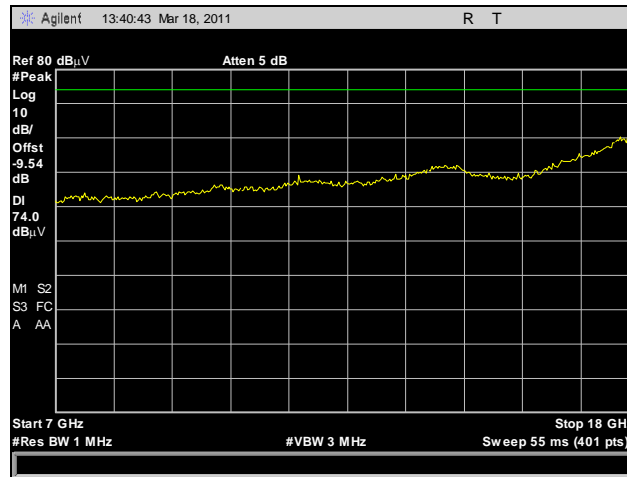

Plot 168. Radiated Spurious Emissions, HT10, Mid Channel, 7 GHz – 18 GHz, Peak

Radiated Spurious Emissions, HT10, High Channel

Frequency (MHz)	Antenna Polarity	EUT Azimuth (Degrees)	Antenna Height (cm)	Uncorrected Amplitude (dBuV)	ACF (dB/m)	Pre Amp Gain (dB)	CBL (dB)	DCF (dB)	Corrected Amplitude (dBuV)	Limit (dBuV)	Margin (dB)
76.9	V	107.9	142.6	60.02	6.57	40	1.412	10.46	38.462	40	-1.538

Table 31. Radiated Spurious Emissions, Test Results, HT10, High Channel

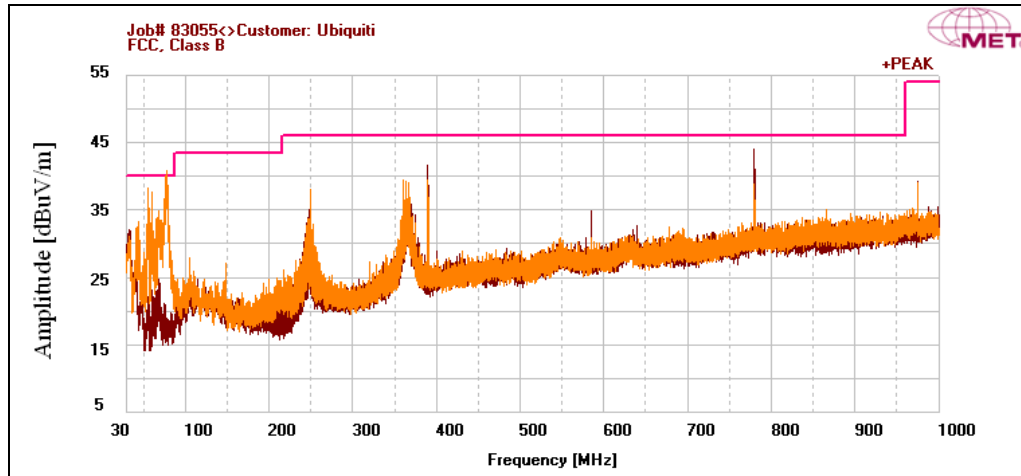

Plot 169. Radiated Spurious Emissions, HT10, High Channel, 30 MHz – 1 GHz

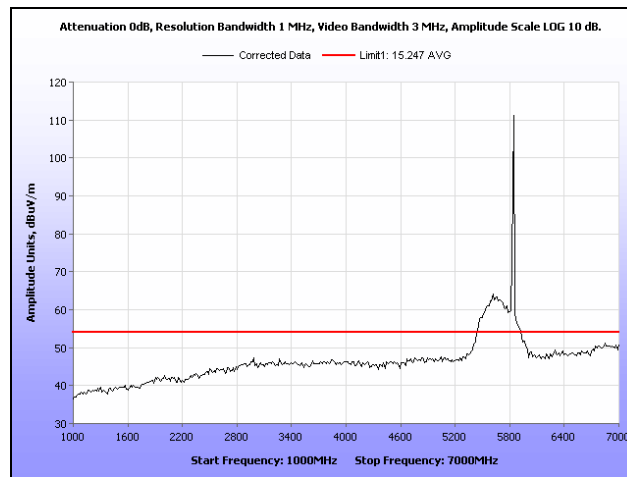

Plot 170. Radiated Spurious Emissions, HT10, High Channel, 1 GHz – 7 GHz, Average

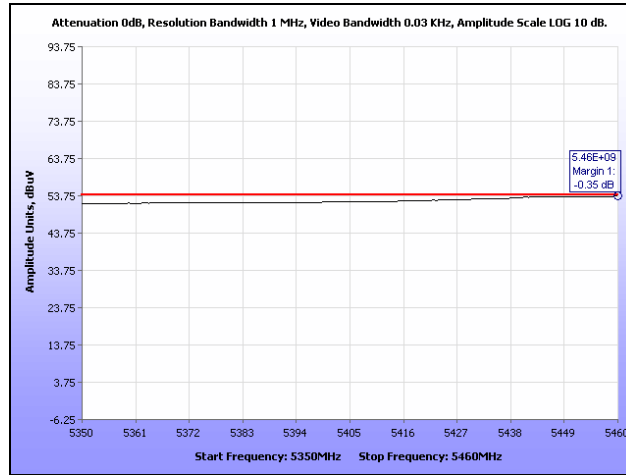

Plot 171. Restricted Band, HT10, High Channel

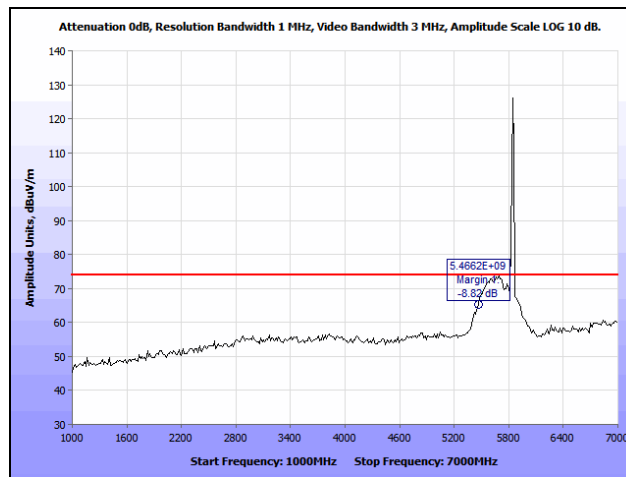

Plot 172. Radiated Spurious Emissions, HT10, High Channel, 1 GHz – 7 GHz, Peak

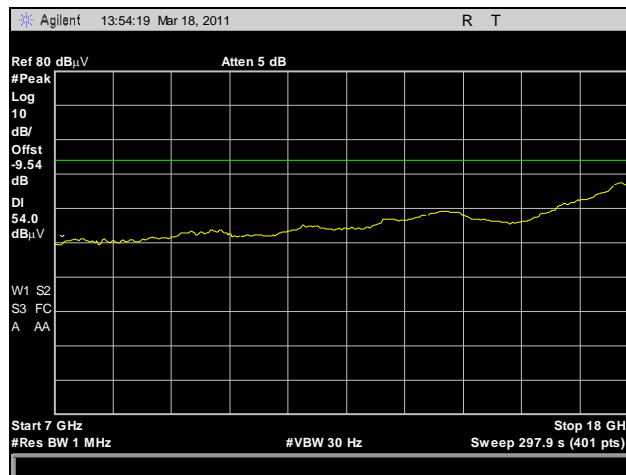

Plot 173. Radiated Spurious Emissions, HT10, High Channel, 7 GHz – 18 GHz, Average

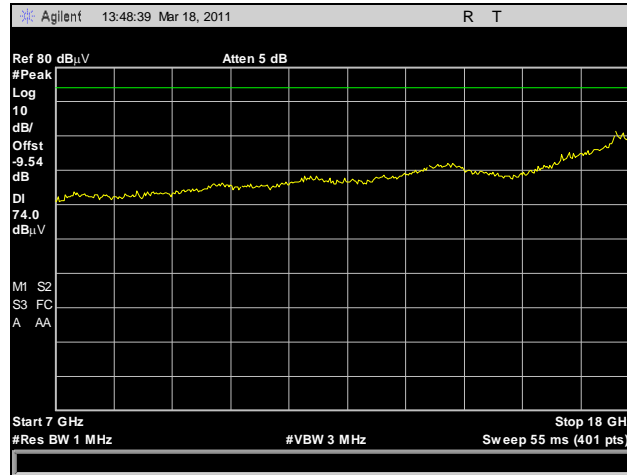

Plot 174. Radiated Spurious Emissions, HT10, High Channel, 7 GHz – 18 GHz, Peak

Radiated Spurious Emissions, HT20, Low Channel

Frequency (MHz)	Antenna Polarity	EUT Azimuth (Degrees)	Antenna Height (cm)	Uncorrected Amplitude (dBuV)	ACF (dB/m)	Pre Amp Gain (dB)	CBL (dB)	DCF (dB)	Corrected Amplitude (dBuV)	Limit (dBuV)	Margin (dB)
76.98	V	242.7	172.5	61.12	6.594	40	1.412	10.46	39.586	40	-0.414

Table 32. Radiated Spurious Emissions, Test Results, HT20, Low Channel

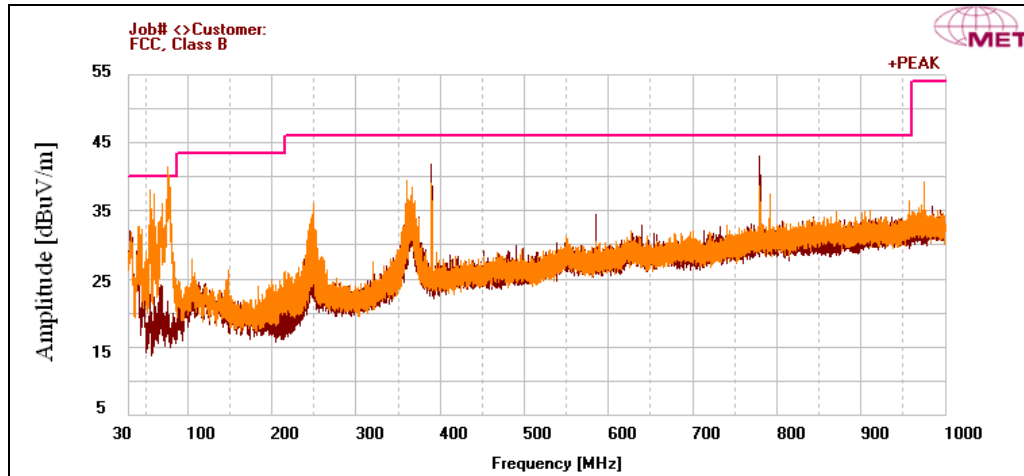

Plot 175. Radiated Spurious Emissions, HT20, Low Channel, 30 MHz – 1 GHz

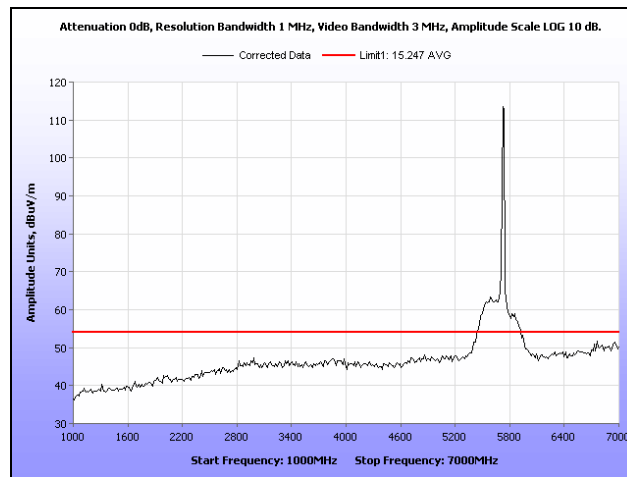

Plot 176. Radiated Spurious Emissions, HT20, Low Channel, 1 GHz – 7 GHz, Average

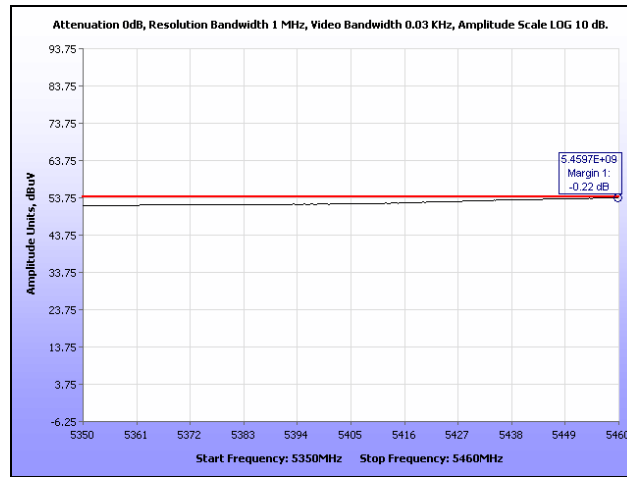

Plot 177. Restricted Band, HT20, Low Channel

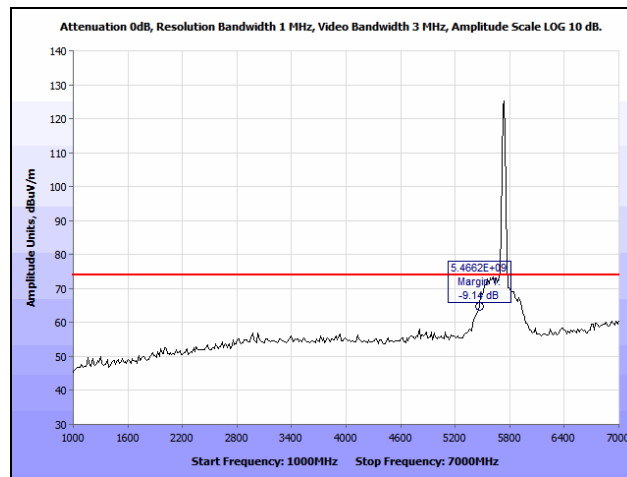

Plot 178. Radiated Spurious Emissions, HT20, Low Channel, 1 GHz – 7 GHz, Peak

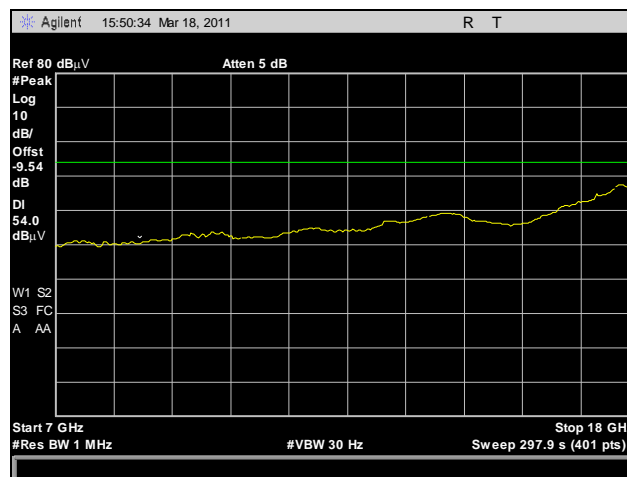

Plot 179. Radiated Spurious Emissions, HT20, Low Channel, 7 GHz – 18 GHz, Average

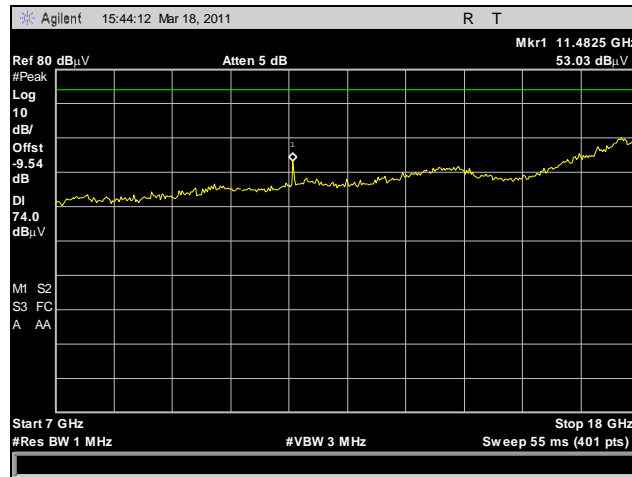

Plot 180. Radiated Spurious Emissions, HT20, Low Channel, 7 GHz – 18 GHz, Peak

Radiated Spurious Emissions, HT20, Mid Channel

Frequency (MHz)	Antenna Polarity	EUT Azimuth (Degrees)	Antenna Height (cm)	Uncorrected Amplitude (dBuV)	ACF (dB/m)	Pre Amp Gain (dB)	CBL (dB)	DCF (dB)	Corrected Amplitude (dBuV)	Limit (dBuV)	Margin (dB)
76.979	V	213.8	168.5	61.24	6.594	40	1.412	10.46	39.706	40	-0.294

Table 33. Radiated Spurious Emissions, Test Results, HT20, Mid Channel

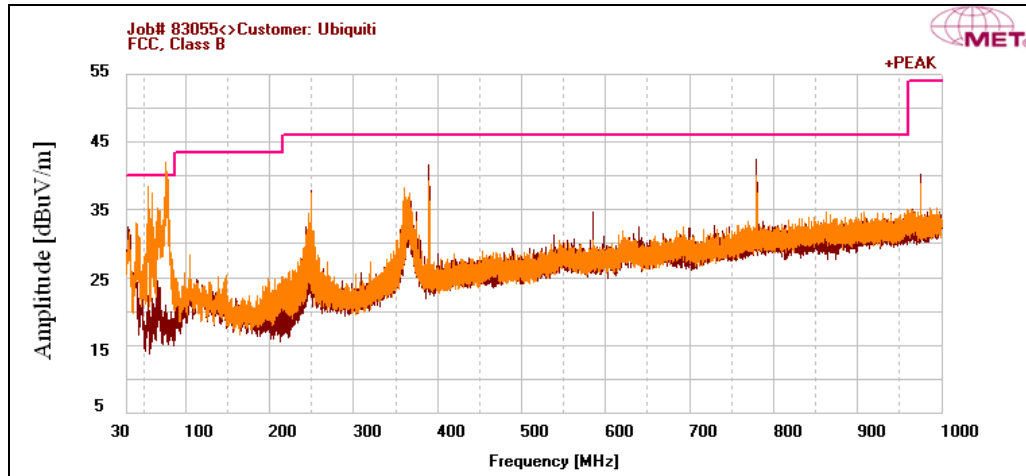

Plot 181. Radiated Spurious Emissions, HT20, Mid Channel, 30 MHz – 1 GHz

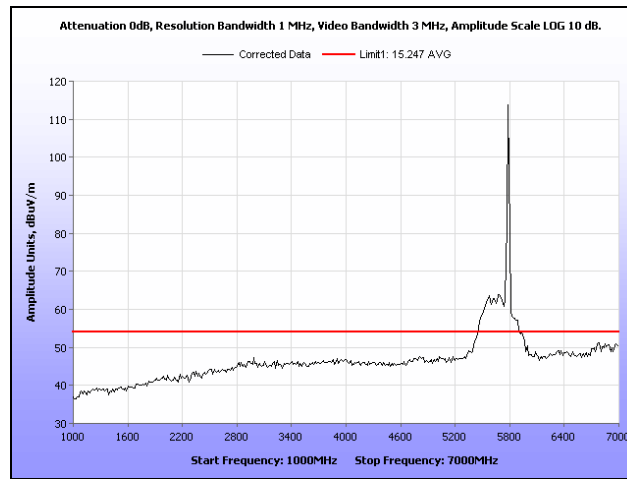

Plot 182. Radiated Spurious Emissions, HT20, Mid Channel, 1 GHz – 7 GHz, Average

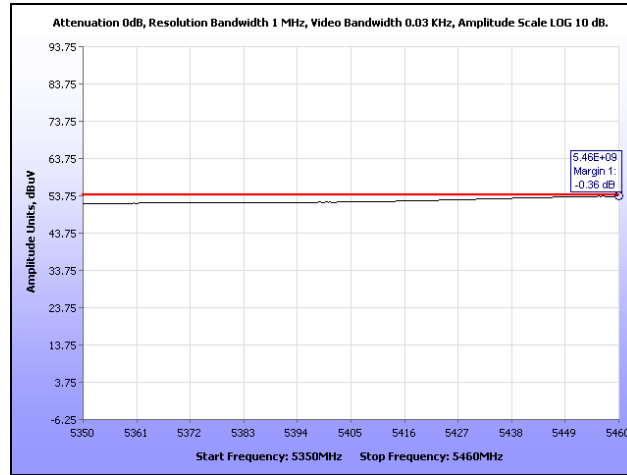

Plot 183. Restricted Band, HT20, Mid Channel

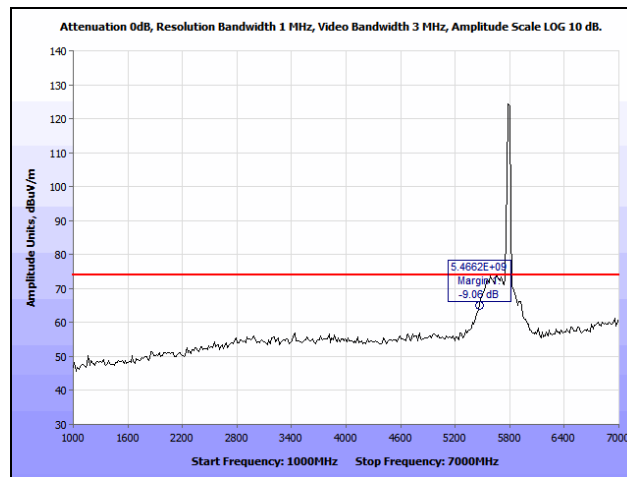

Plot 184. Radiated Spurious Emissions, HT20, Mid Channel, 1 GHz – 7 GHz, Peak

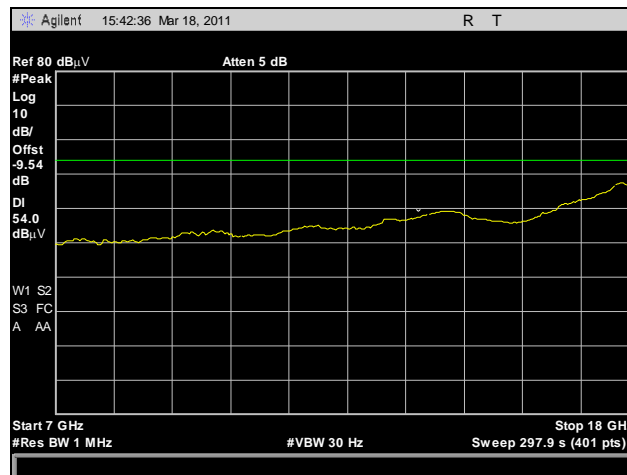

Plot 185. Radiated Spurious Emissions, HT20, Mid Channel, 7 GHz – 18 GHz, Average

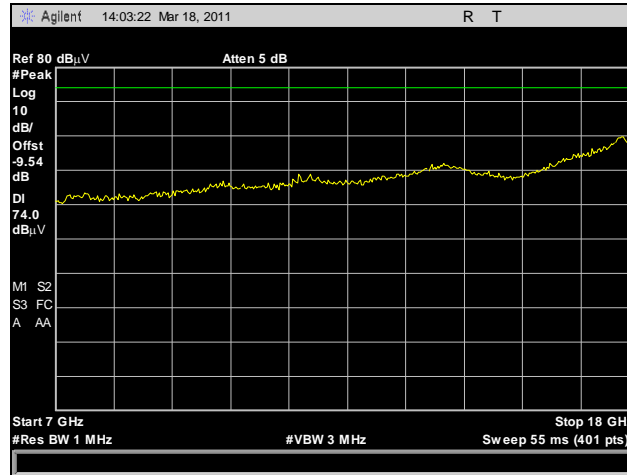

Plot 186. Radiated Spurious Emissions, HT20, Mid Channel, 7 GHz – 18 GHz, Peak

Radiated Spurious Emissions, HT20, High Channel

Frequency (MHz)	Antenna Polarity	EUT Azimuth (Degrees)	Antenna Height (cm)	Uncorrected Amplitude (dBuV)	ACF (dB/m)	Pre Amp Gain (dB)	CBL (dB)	DCF (dB)	Corrected Amplitude (dBuV)	Limit (dBuV)	Margin (dB)
77.023	V	239.4	165.7	61.13	6.605	40	1.412	10.46	39.607	40	-0.393

Table 34. Radiated Spurious Emissions, Test Results, HT20, High Channel

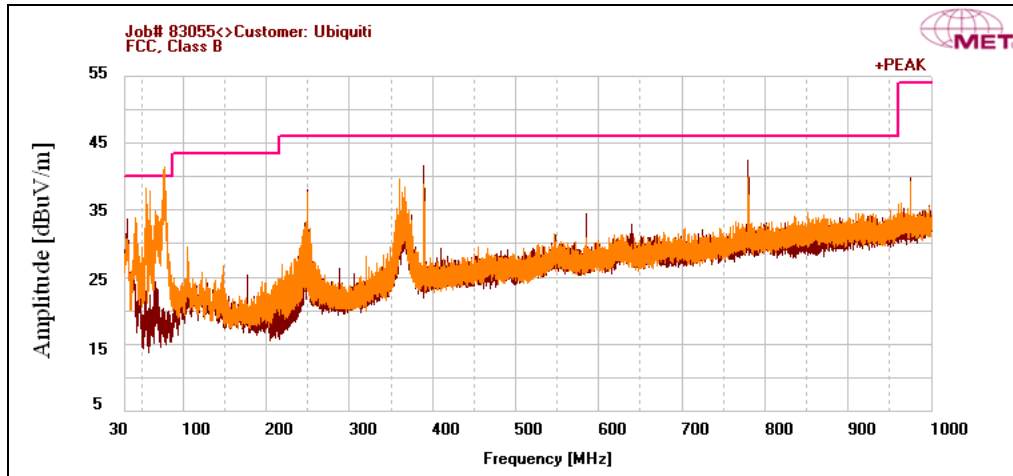

Plot 187. Radiated Spurious Emissions, HT20, High Channel, 30 MHz – 1 GHz

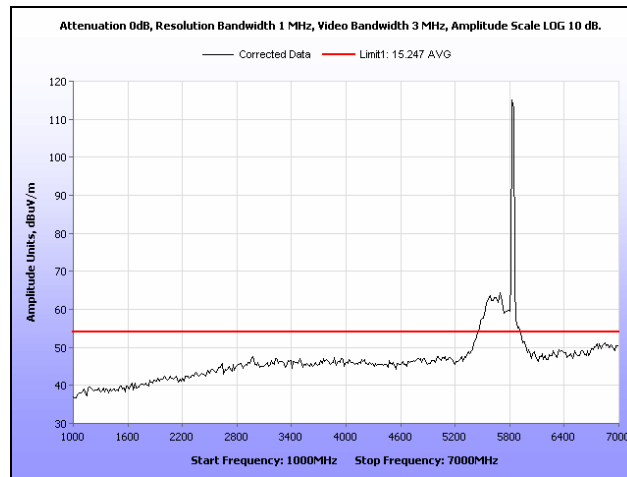

Plot 188. Radiated Spurious Emissions, HT20, High Channel, 1 GHz – 7 GHz, Average

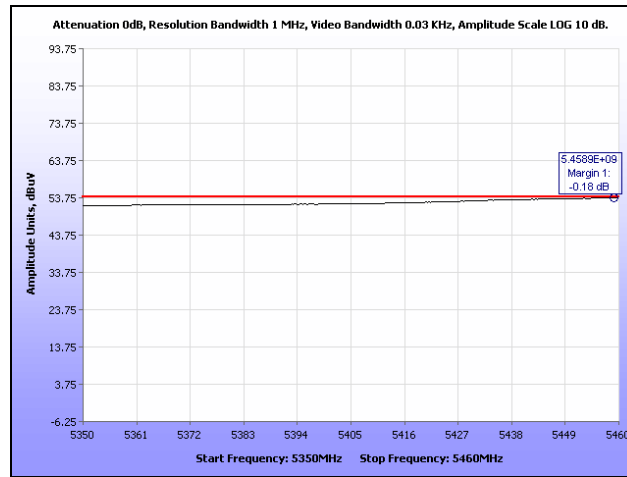

Plot 189. Restricted Band, HT20, High Channel

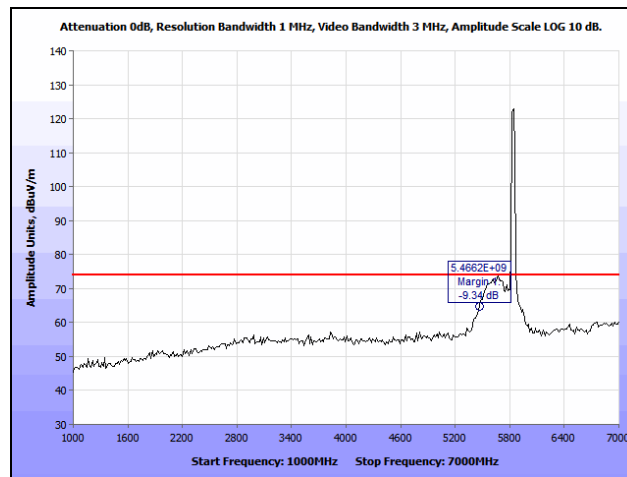

Plot 190. Radiated Spurious Emissions, HT20, High Channel, 1 GHz – 7 GHz, Peak

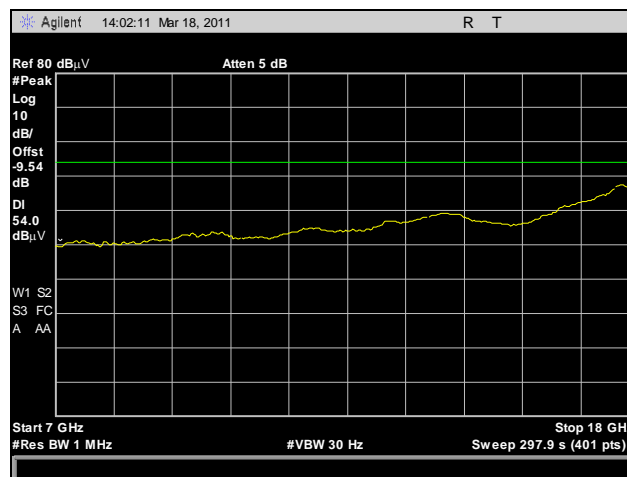

Plot 191. Radiated Spurious Emissions, HT20, High Channel, 7 GHz – 18 GHz, Average

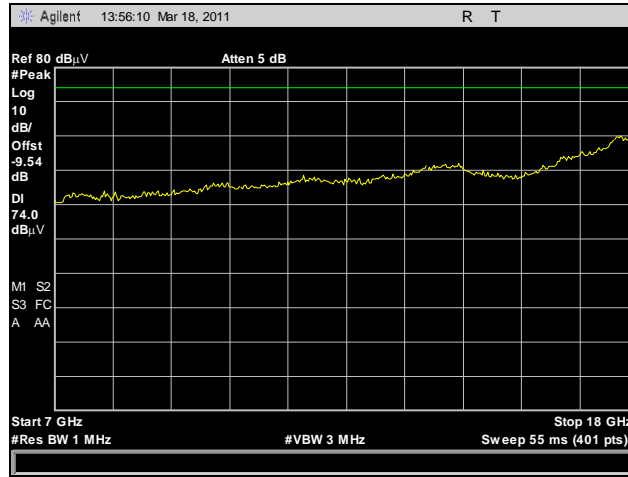

Plot 192. Radiated Spurious Emissions, HT20, High Channel, 7 GHz – 18 GHz, Peak

Radiated Spurious Emissions, HT30, Low Channel

Frequency (MHz)	Antenna Polarity	EUT Azimuth (Degrees)	Antenna Height (cm)	Uncorrected Amplitude (dBuV)	ACF (dB/m)	Pre Amp Gain (dB)	CBL (dB)	DCF (dB)	Corrected Amplitude (dBuV)	Limit (dBuV)	Margin (dB)
76.97	V	84.3	156.7	61.37	6.591	40	1.412	10.46	39.833	40	-0.167

Table 35. Radiated Spurious Emissions, Test Results, HT30, Low Channel

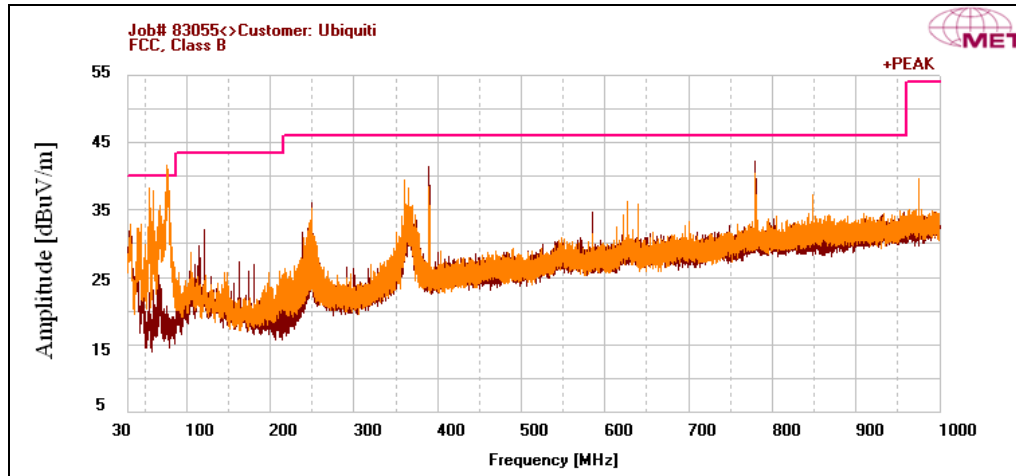

Plot 193. Radiated Spurious Emissions, HT30, Low Channel, 30 MHz – 1 GHz

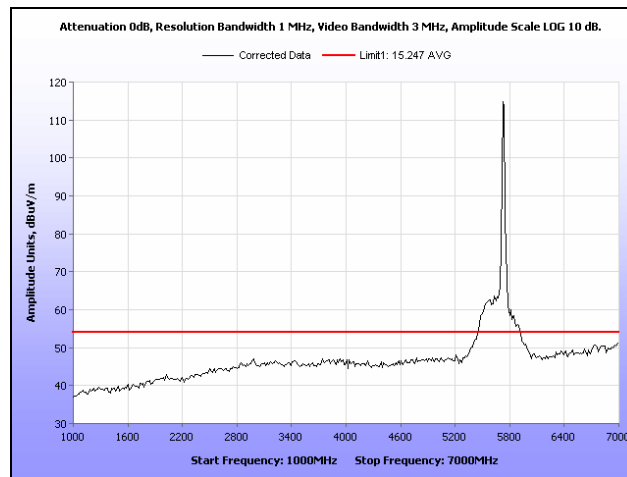

Plot 194. Radiated Spurious Emissions, HT30, Low Channel, 1 GHz – 7 GHz, Average

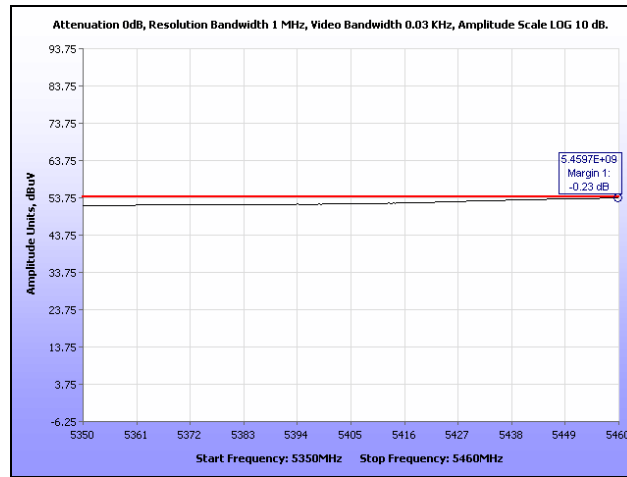

Plot 195. Restricted Band, HT30, Low Channel

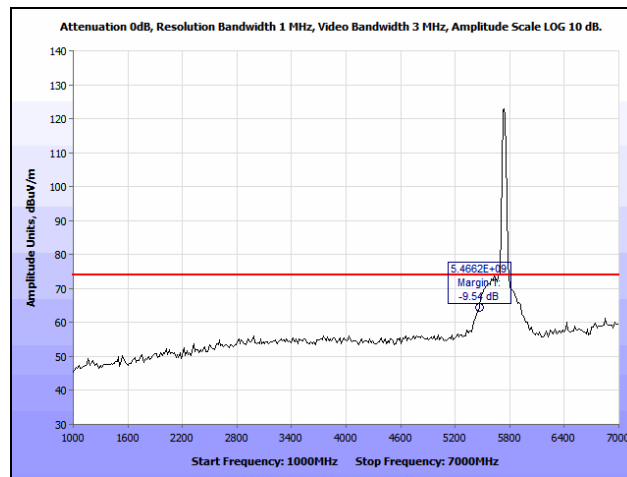

Plot 196. Radiated Spurious Emissions, HT30, Low Channel, 1 GHz – 7 GHz, Peak

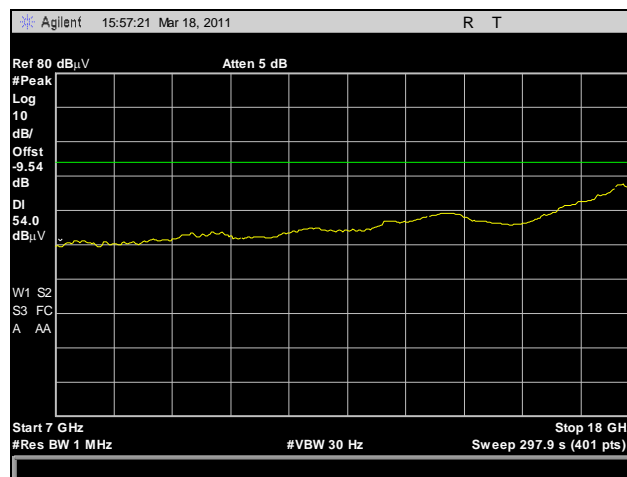

Plot 197. Radiated Spurious Emissions, HT30, Low Channel, 7 GHz – 18 GHz, Average

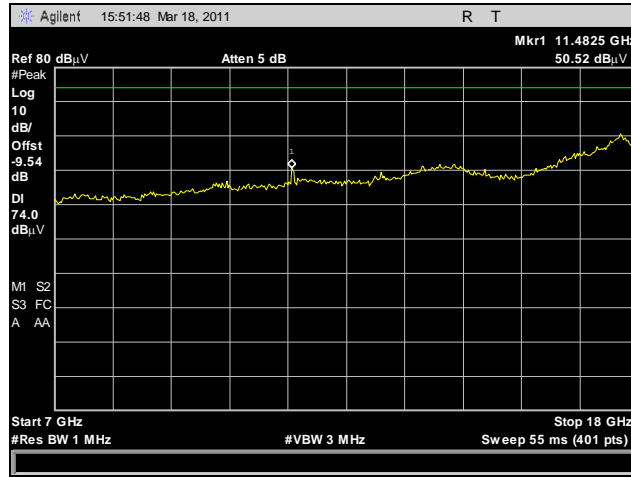

Plot 198. Radiated Spurious Emissions, HT30, Low Channel, 7 GHz – 18 GHz, Peak

Radiated Spurious Emissions, HT30, Mid Channel

Frequency (MHz)	Antenna Polarity	EUT Azimuth (Degrees)	Antenna Height (cm)	Uncorrected Amplitude (dBuV)	ACF (dB/m)	Pre Amp Gain (dB)	CBL (dB)	DCF (dB)	Corrected Amplitude (dBuV)	Limit (dBuV)	Margin (dB)
76.97	V	51.7	167.3	60.81	6.591	40	1.412	10.46	39.273	40	-0.727

Table 36. Radiated Spurious Emissions, Test Results, HT30, Mid Channel

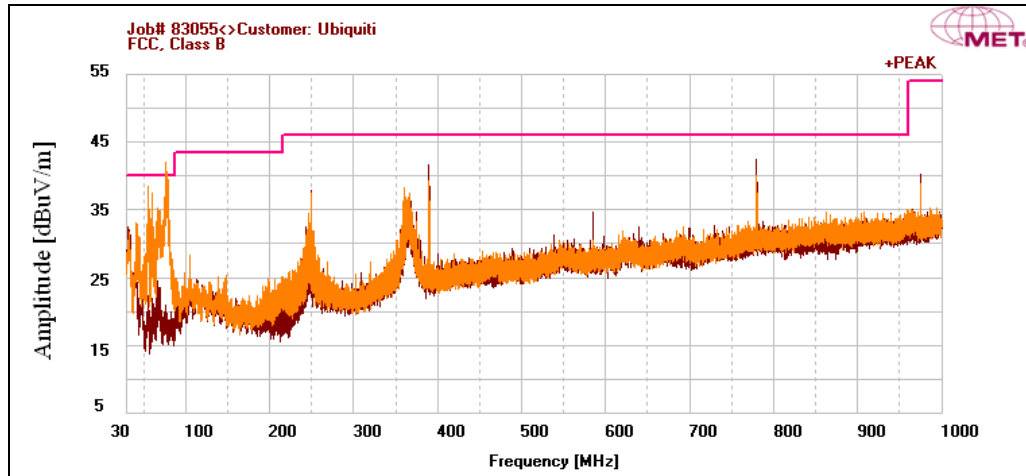

Plot 199. Radiated Spurious Emissions, HT30, Mid Channel, 30 MHz – 1 GHz

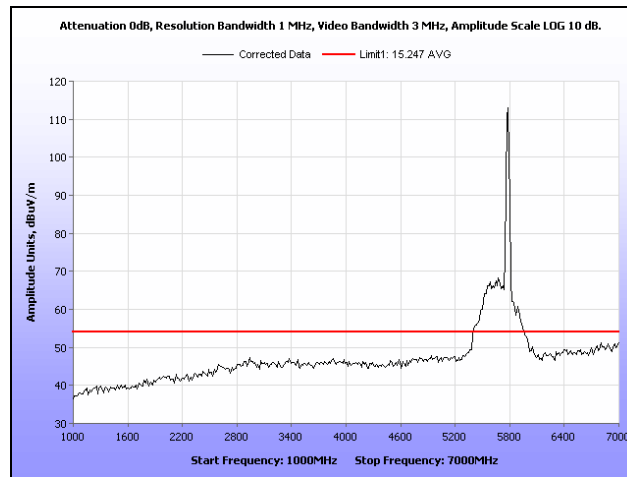

Plot 200. Radiated Spurious Emissions, HT30, Mid Channel, 1 GHz – 7 GHz, Average

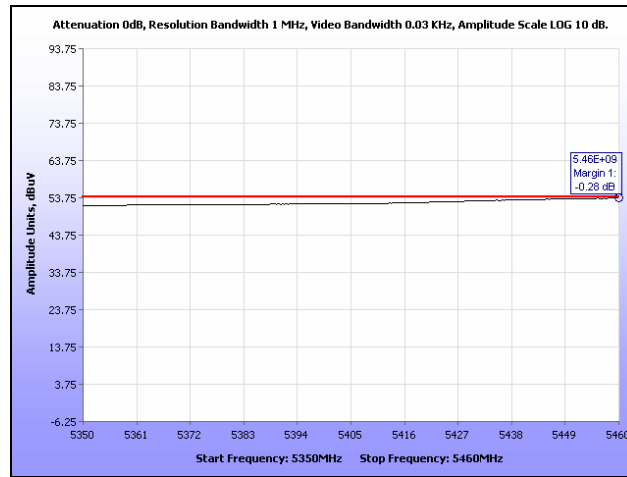

Plot 201. Restricted Band, HT30, Mid Channel

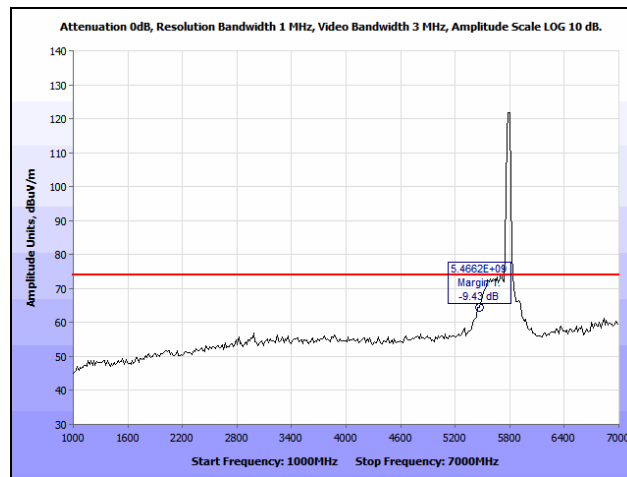

Plot 202. Radiated Spurious Emissions, HT30, Mid Channel, 1 GHz – 7 GHz, Peak

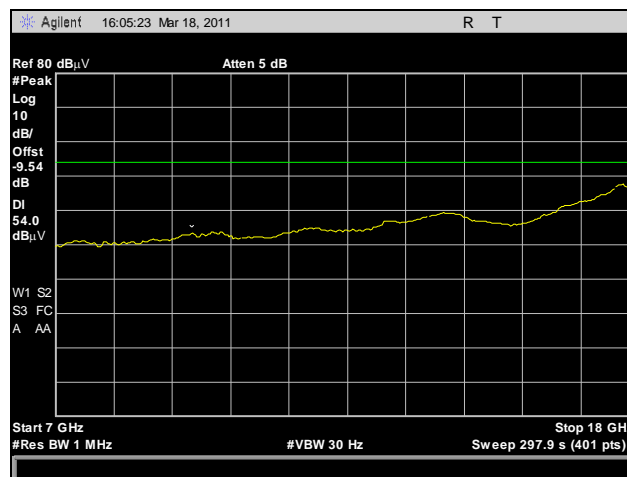

Plot 203. Radiated Spurious Emissions, HT30, Mid Channel, 7 GHz – 18 GHz, Average

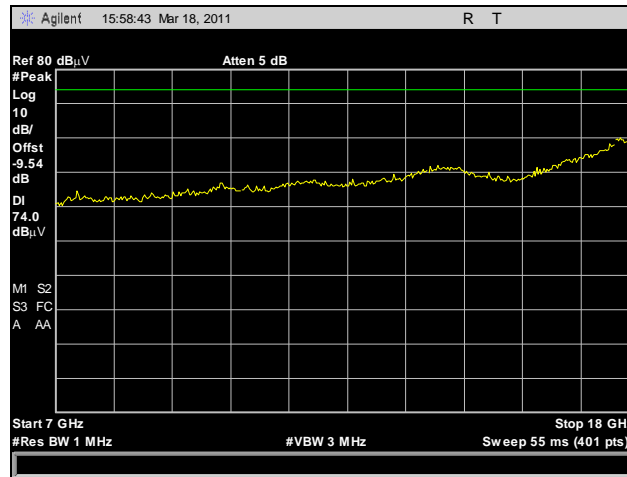

Plot 204. Radiated Spurious Emissions, HT30, Mid Channel, 7 GHz – 18 GHz, Peak

Radiated Spurious Emissions, HT30, High Channel

Frequency (MHz)	Antenna Polarity	EUT Azimuth (Degrees)	Antenna Height (cm)	Uncorrected Amplitude (dBuV)	ACF (dB/m)	Pre Amp Gain (dB)	CBL (dB)	DCF (dB)	Corrected Amplitude (dBuV)	Limit (dBuV)	Margin (dB)
77.3	V	63.6	184.7	59.78	6.66	40	1.413	10.46	38.313	40	-1.687

Table 37. Radiated Spurious Emissions, Test Results, HT30, High Channel

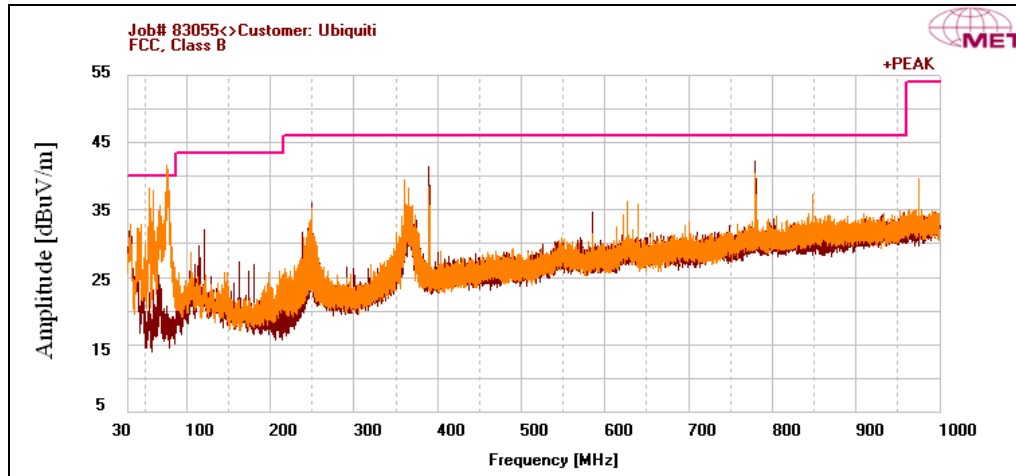

Plot 205. Radiated Spurious Emissions, HT30, High Channel, 30 MHz – 1 GHz

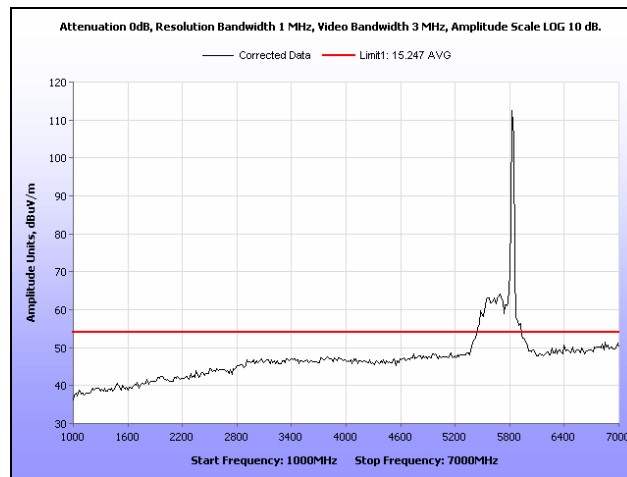

Plot 206. Radiated Spurious Emissions, HT30, High Channel, 1 GHz – 7 GHz, Average

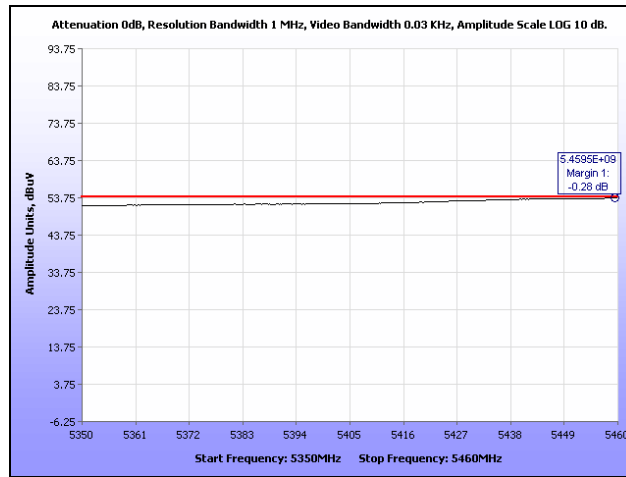

Plot 207. Restricted Band, HT30, High Channel

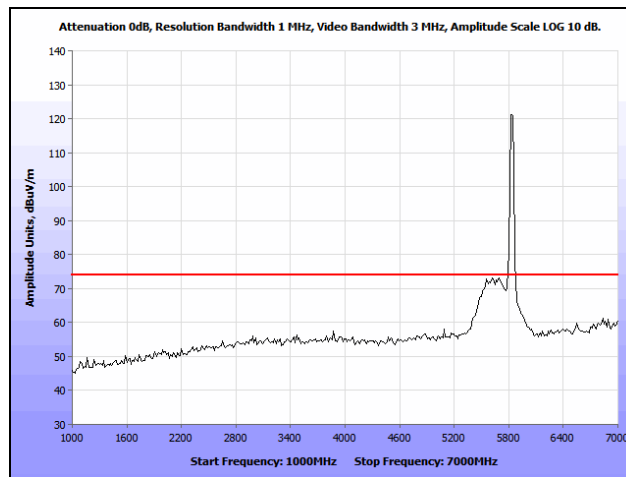

Plot 208. Radiated Spurious Emissions, HT30, High Channel, 1 GHz – 7 GHz, Peak

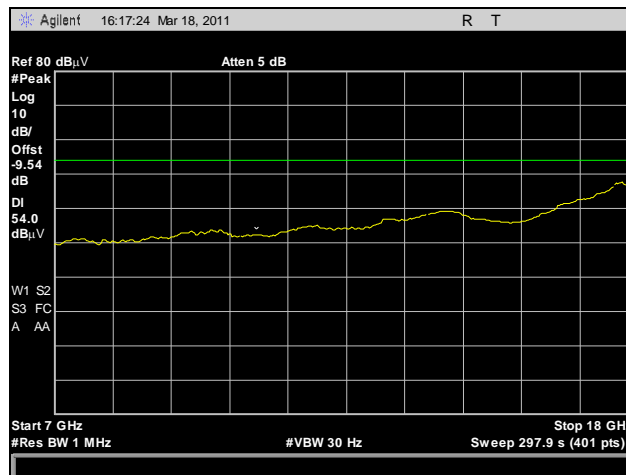

Plot 209. Radiated Spurious Emissions, HT30, High Channel, 7 GHz – 18 GHz, Peak

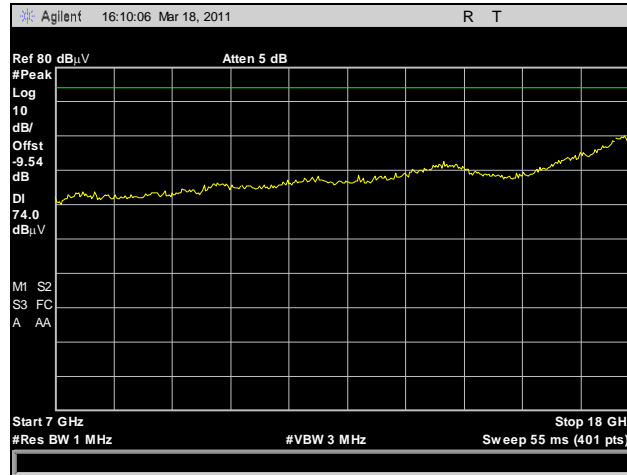

Plot 210. Radiated Spurious Emissions, HT30, High Channel, 7 GHz – 18 GHz, Average

Radiated Spurious Emissions, HT40, Low Channel

Frequency (MHz)	Antenna Polarity	EUT Azimuth (Degrees)	Antenna Height (cm)	Uncorrected Amplitude (dBuV)	ACF (dB/m)	Pre Amp Gain (dB)	CBL (dB)	DCF (dB)	Corrected Amplitude (dBuV)	Limit (dBuV)	Margin (dB)
76.62	V	117.6	189.7	59.75	6.486	40	1.409	10.46	38.105	40	-1.895

Table 38. Radiated Spurious Emissions, Test Results, HT40, Low Channel

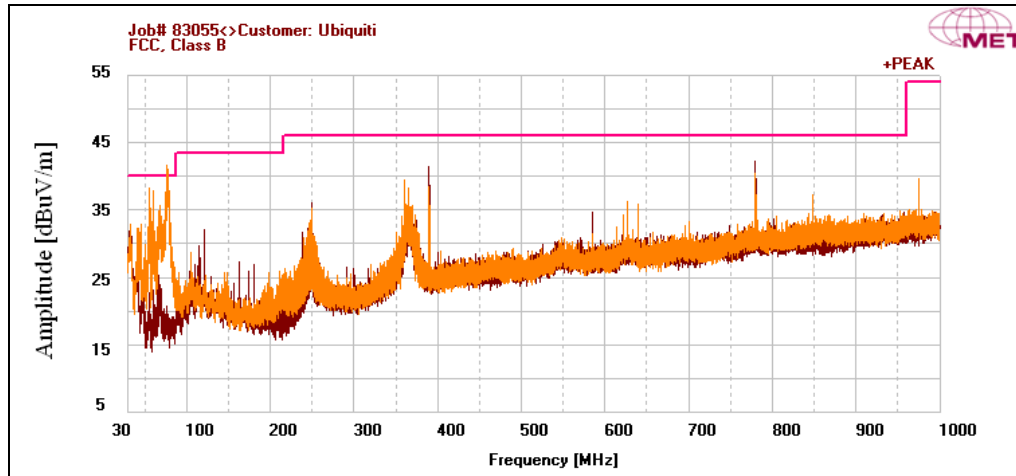

Plot 211. Radiated Spurious Emissions, HT40, Low Channel, 30 MHz – 1 GHz

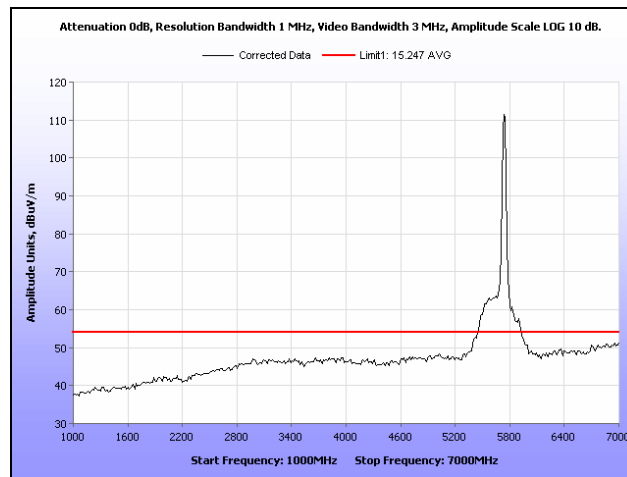

Plot 212. Radiated Spurious Emissions, HT40, Low Channel, 1 GHz – 7 GHz, Average

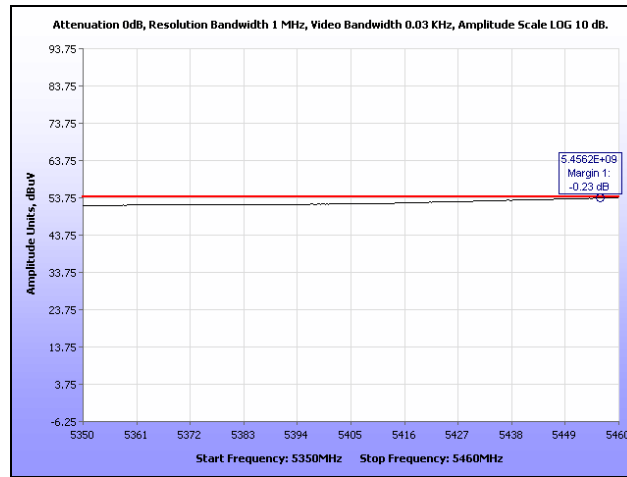

Plot 213. Restricted Band, HT40, Low Channel

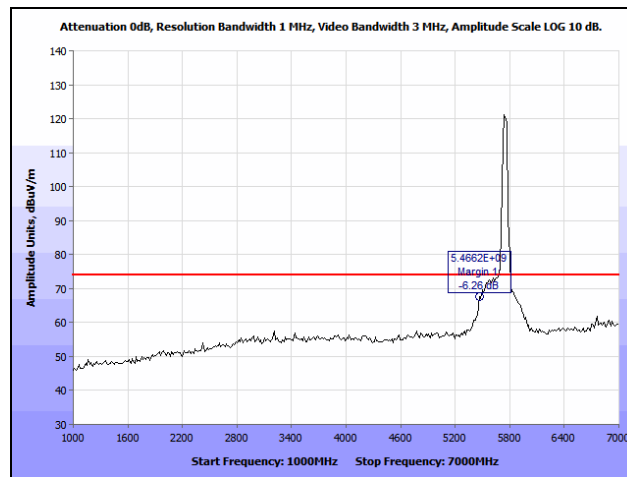

Plot 214. Radiated Spurious Emissions, HT40, Low Channel, 1 GHz – 7 GHz, Peak

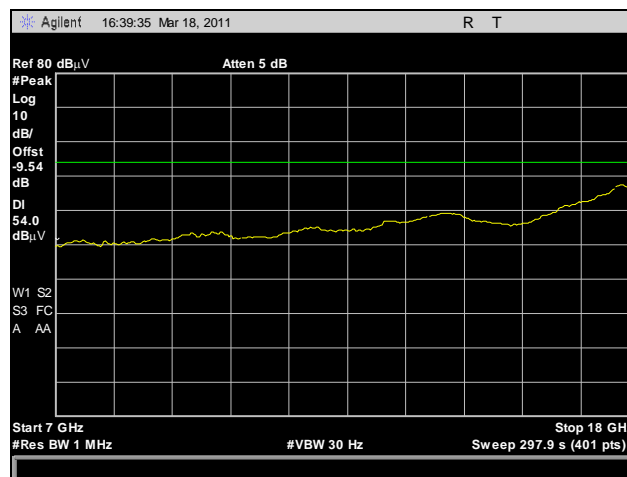

Plot 215. Radiated Spurious Emissions, HT40, Low Channel, 7 GHz – 18 GHz, Average

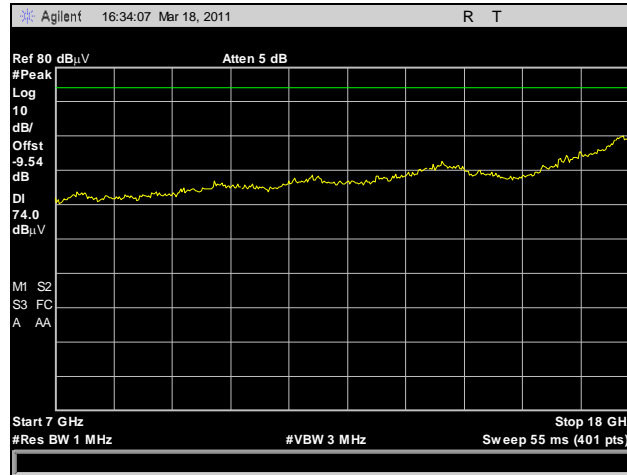

Plot 216. Radiated Spurious Emissions, HT40, Low Channel, 7 GHz – 18 GHz, Peak

Radiated Spurious Emissions, HT30, Mid Channel

Frequency (MHz)	Antenna Polarity	EUT Azimuth (Degrees)	Antenna Height (cm)	Uncorrected Amplitude (dBuV)	ACF (dB/m)	Pre Amp Gain (dB)	CBL (dB)	DCF (dB)	Corrected Amplitude (dBuV)	Limit (dBuV)	Margin (dB)
77.103	V	102.8	174.9	59.12	6.621	40	1.412	10.46	37.613	40	-2.387

Table 39. Radiated Spurious Emissions, Test Results, HT40, Mid Channel

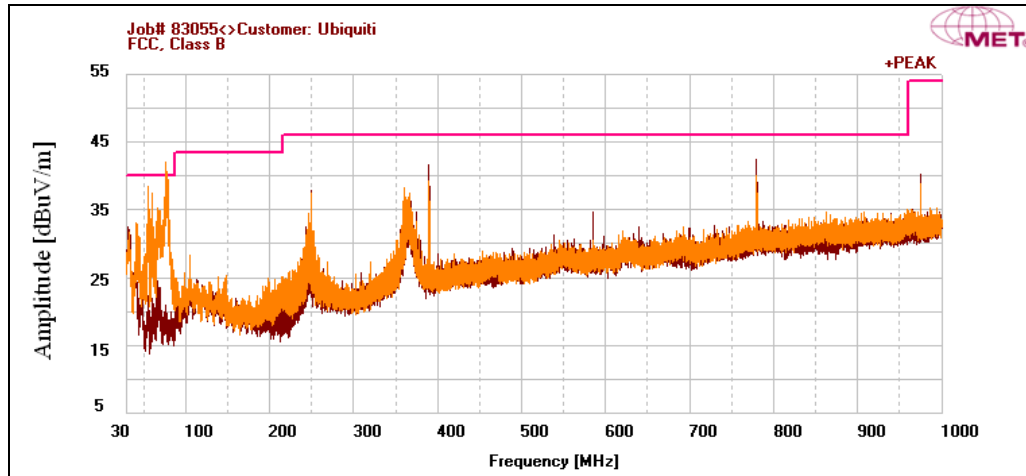

Plot 217. Radiated Spurious Emissions, HT40, Mid Channel, 30 MHz – 1 GHz

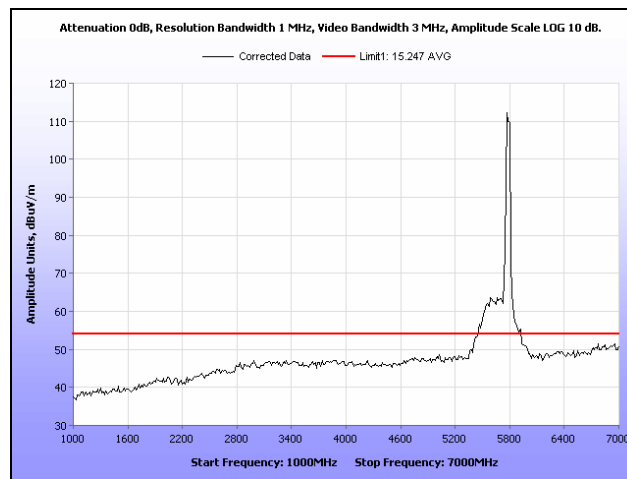

Plot 218. Radiated Spurious Emissions, HT40, Mid Channel, 1 GHz – 7 GHz, Average

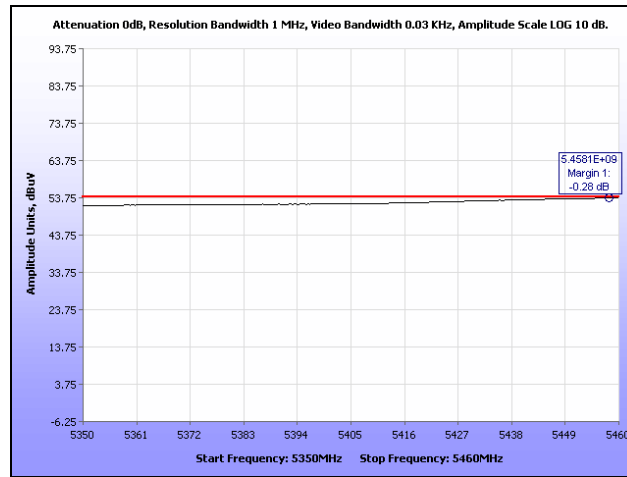

Plot 219. Restricted Band, HT40, Mid Channel

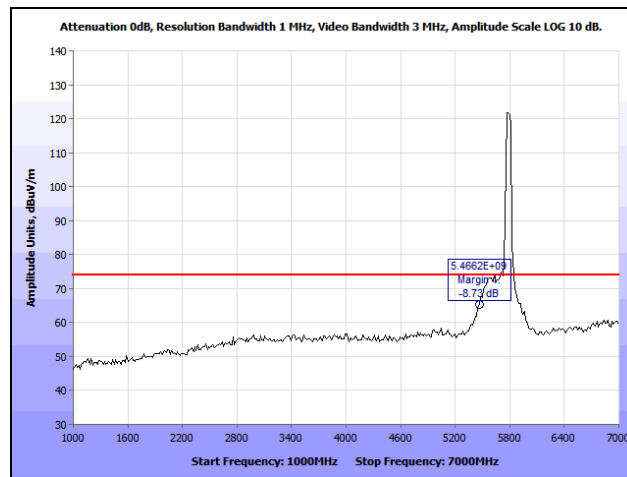

Plot 220. Radiated Spurious Emissions, HT40, Mid Channel, 1 GHz – 7 GHz, Peak

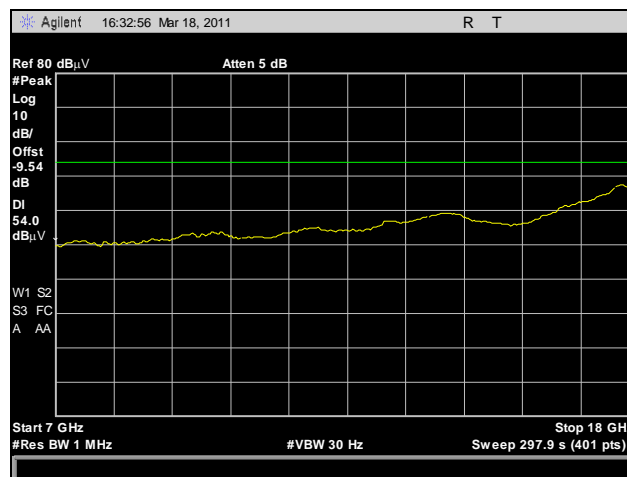

Plot 221. Radiated Spurious Emissions, HT40, Mid Channel, 7 GHz – 18 GHz, Average

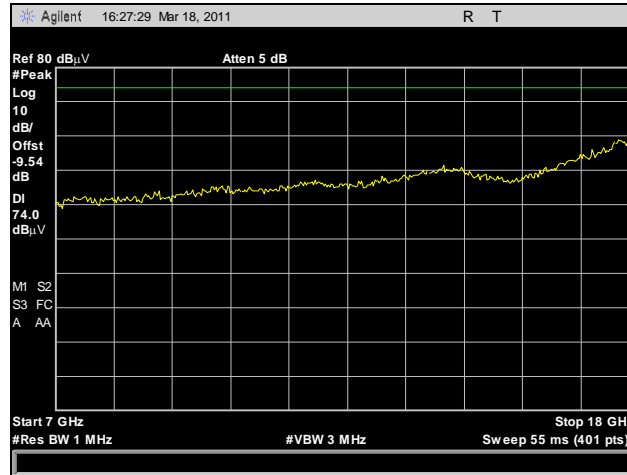

Plot 222. Radiated Spurious Emissions, HT40, Mid Channel, 7 GHz – 18 GHz, Peak

Radiated Spurious Emissions, HT30, High Channel

Frequency (MHz)	Antenna Polarity	EUT Azimuth (Degrees)	Antenna Height (cm)	Uncorrected Amplitude (dBuV)	ACF (dB/m)	Pre Amp Gain (dB)	CBL (dB)	DCF (dB)	Corrected Amplitude (dBuV)	Limit (dBuV)	Margin (dB)
77.023	V	112.7	168.3	59.82	6.605	40	1.412	10.46	38.297	40	-1.703

Table 40. Radiated Spurious Emissions, Test Results, HT40, High Channel

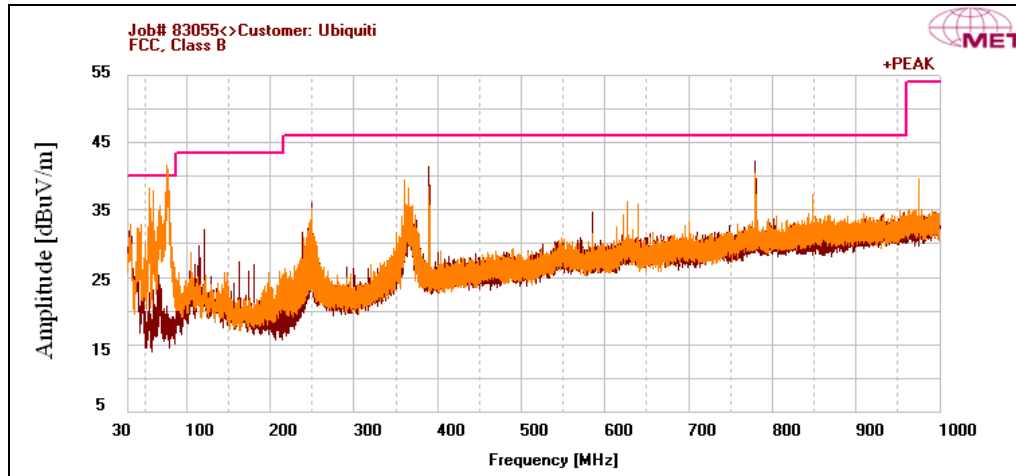

Plot 223. Radiated Spurious Emissions, HT40, High Channel, 30 MHz – 1 GHz

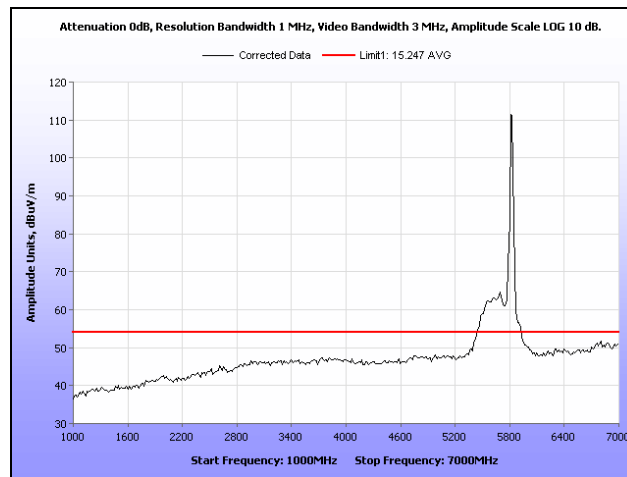

Plot 224. Radiated Spurious Emissions, HT40, High Channel, 1 GHz – 7 GHz, Average

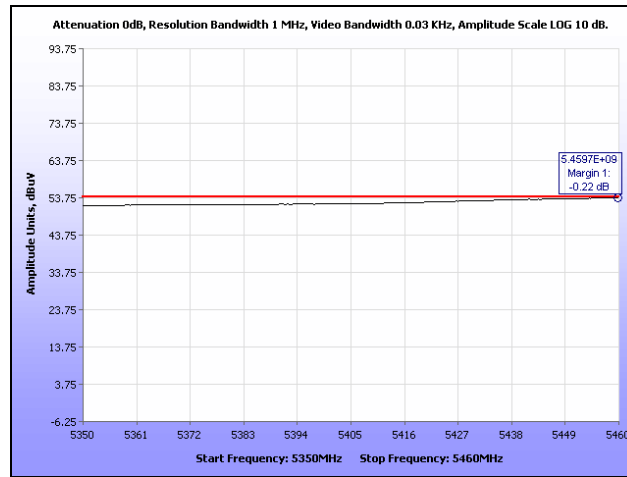

Plot 225. Restricted Band, HT40, High Channel

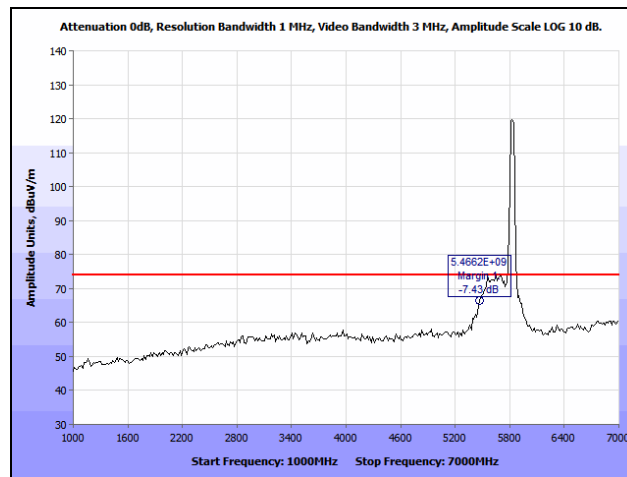

Plot 226. Radiated Spurious Emissions, HT40, High Channel, 1 GHz – 7 GHz, Peak

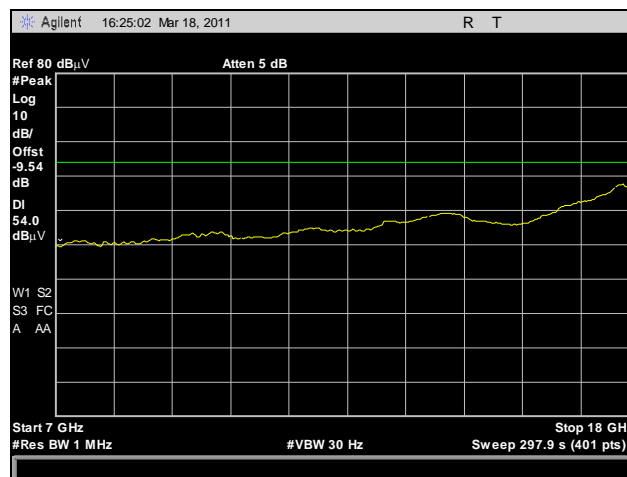

Plot 227. Radiated Spurious Emissions, HT40, High Channel, 7 GHz – 18 GHz, Average

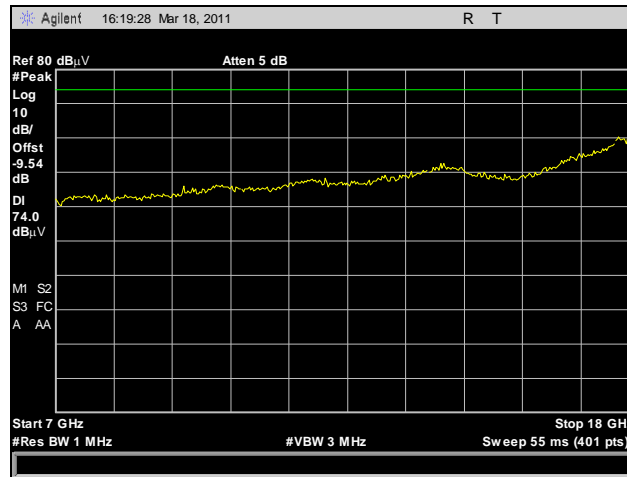

Plot 228. Radiated Spurious Emissions, HT40, High Channel, 7 GHz – 18 GHz, Peak

Radiated Spurious Emissions, Restricted Band

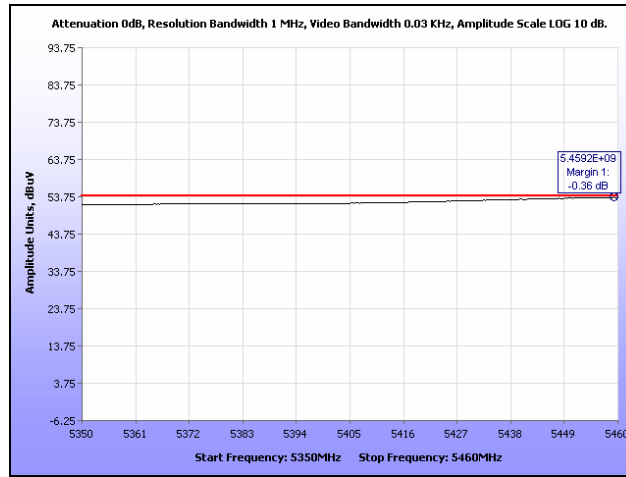

Plot 229. Restricted Band, 802.11a 20 MHz, Low Channel

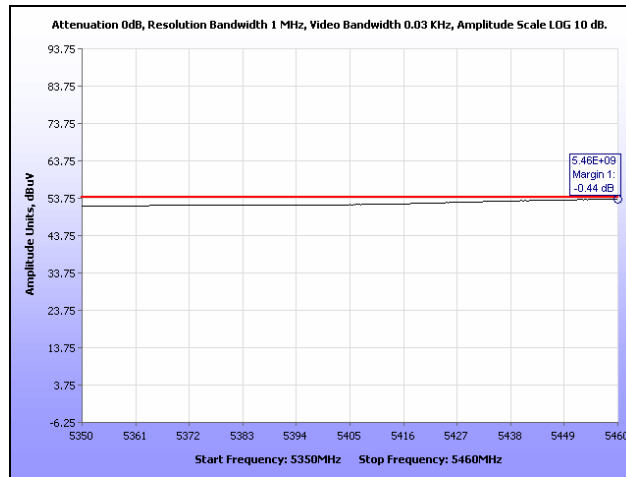

Plot 230. Restricted Band, 802.11a 20 MHz, Mid Channel

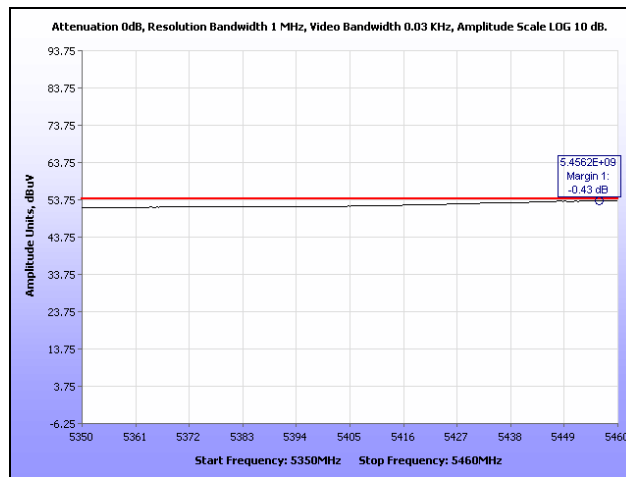

Plot 231. Restricted Band, 802.11a 20 MHz, High Channel

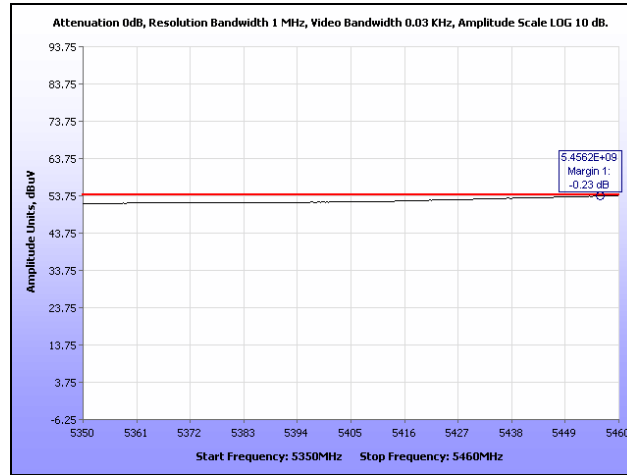

Plot 232. Restricted Band, 802.11a 40 MHz, Low Channel

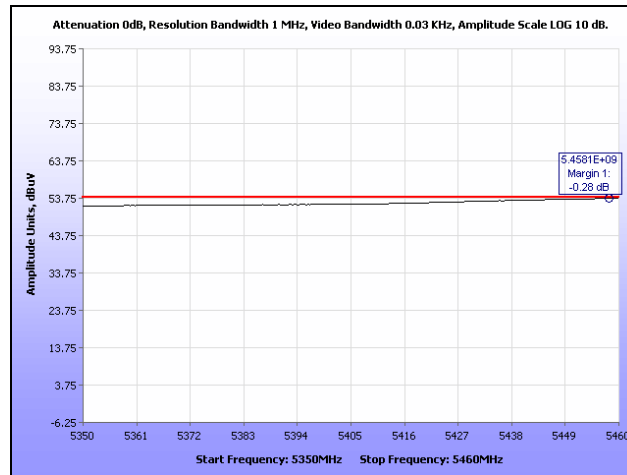

Plot 233. Restricted Band, 802.11a 40 MHz, Mid Channel

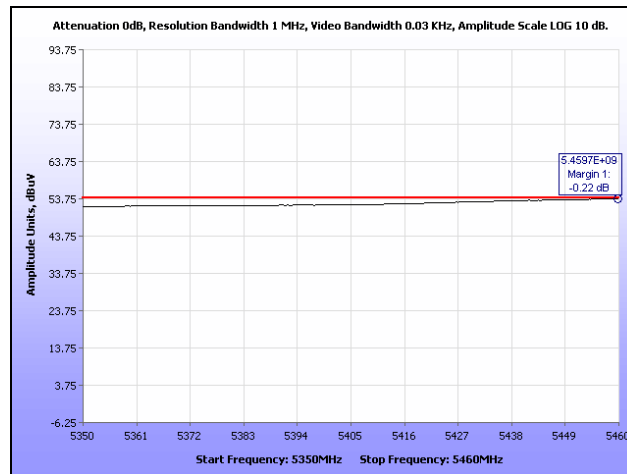

Plot 234. Restricted Band, 802.11a 40 MHz, High Channel

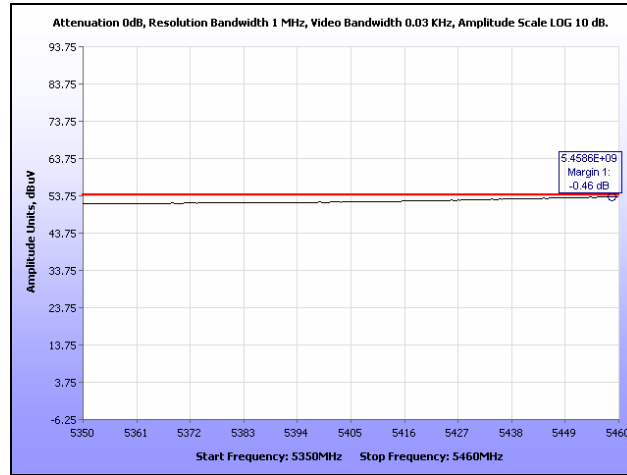

Plot 235. Restricted Band, HT5, Low Channel

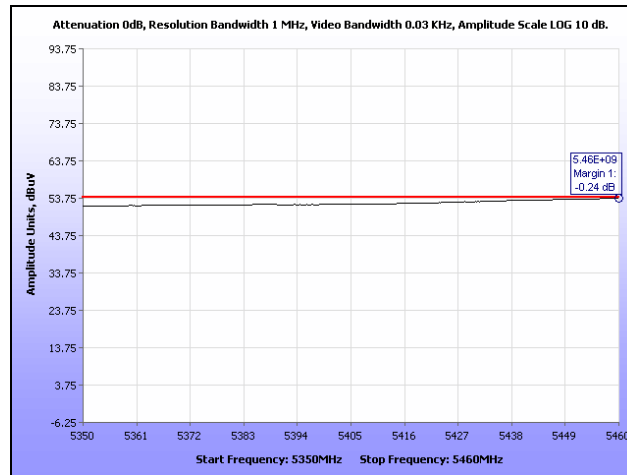

Plot 236. Restricted Band, HT5, Mid Channel

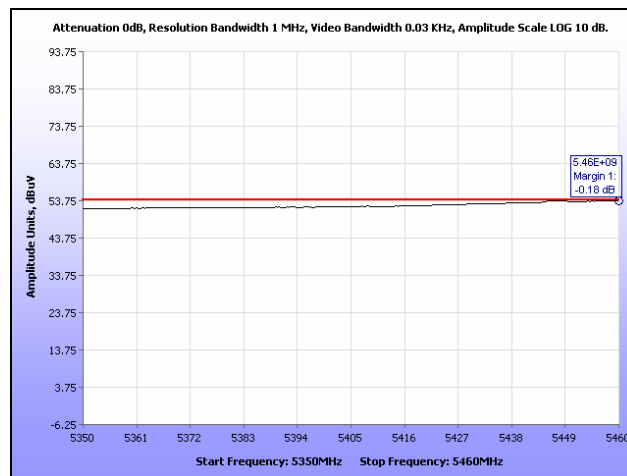

Plot 237. Restricted Band, HT5, High Channel

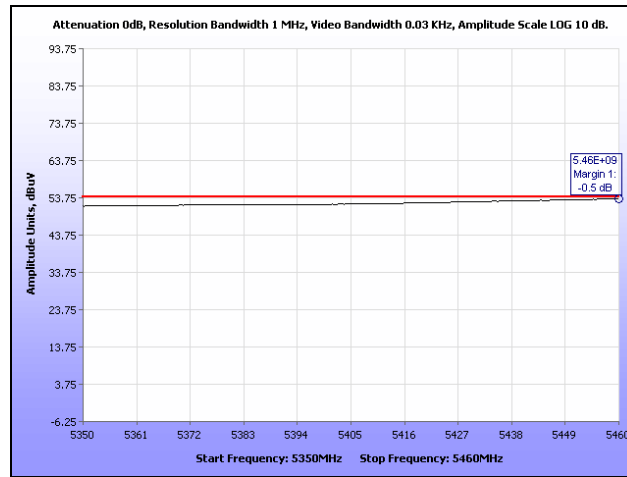

Plot 238. Restricted Band, HT8, Low Channel

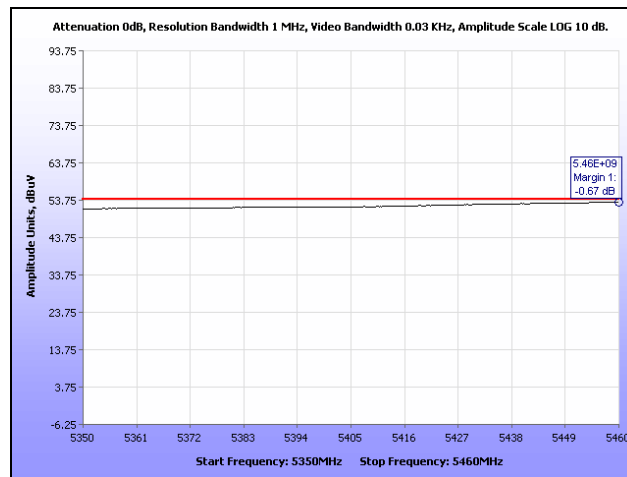

Plot 239. Restricted Band, HT8, Mid Channel

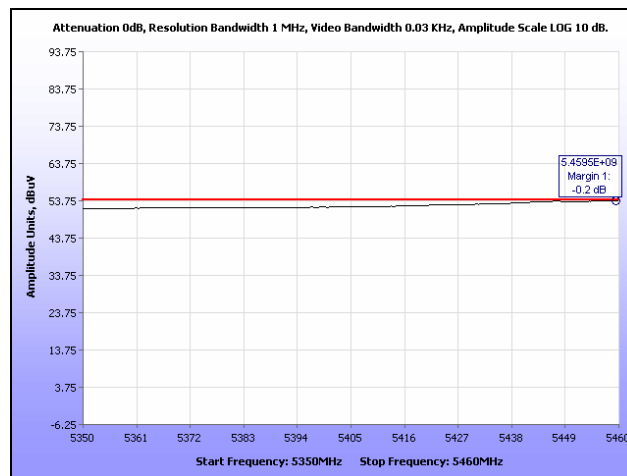

Plot 240. Restricted Band, HT8, High Channel

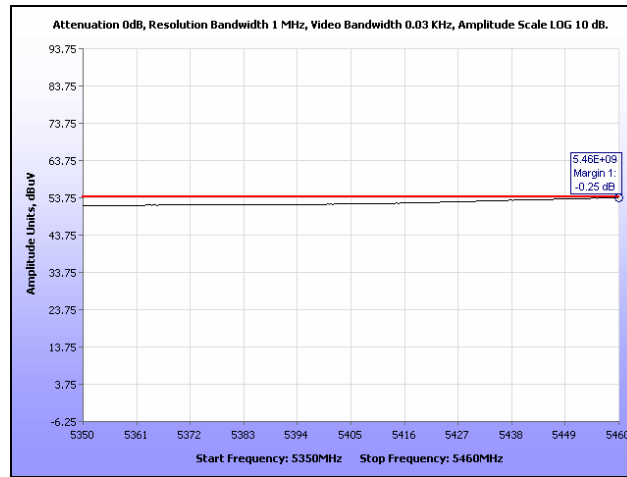

Plot 241. Restricted Band, HT10, Low Channel

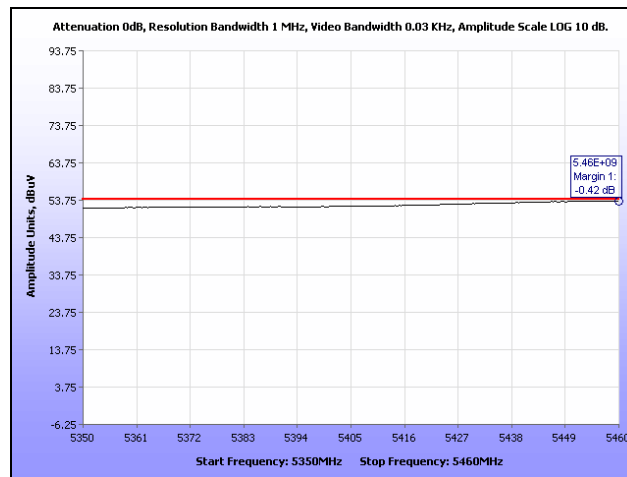

Plot 242. Restricted Band, HT10, Mid Channel

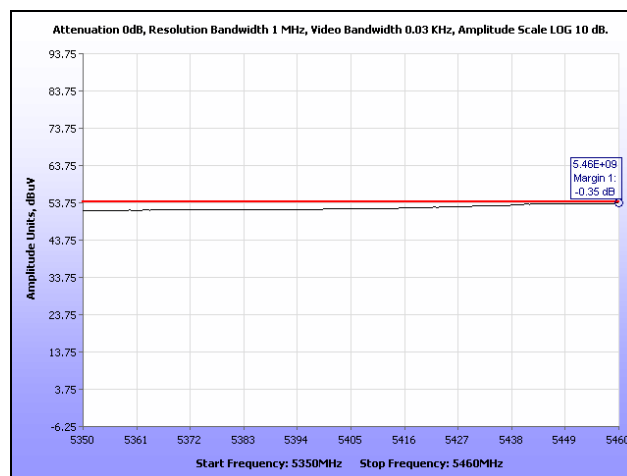

Plot 243. Restricted Band, HT10, High Channel

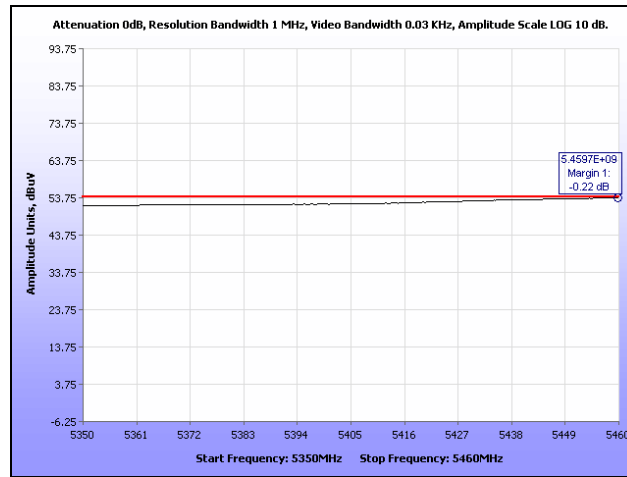

Plot 244. Restricted Band, HT20, Low Channel

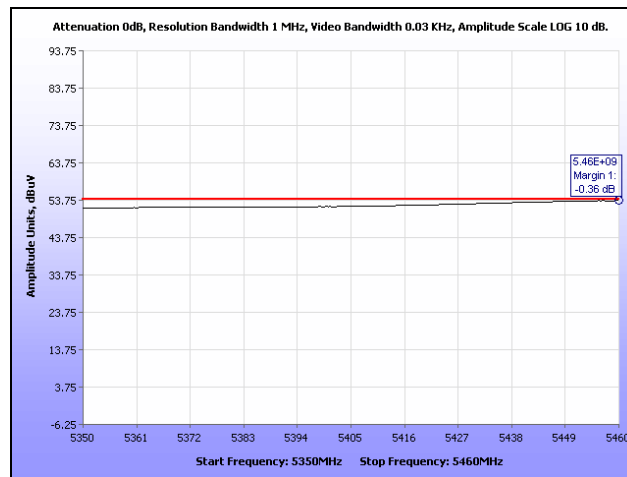

Plot 245. Restricted Band, HT20, Mid Channel

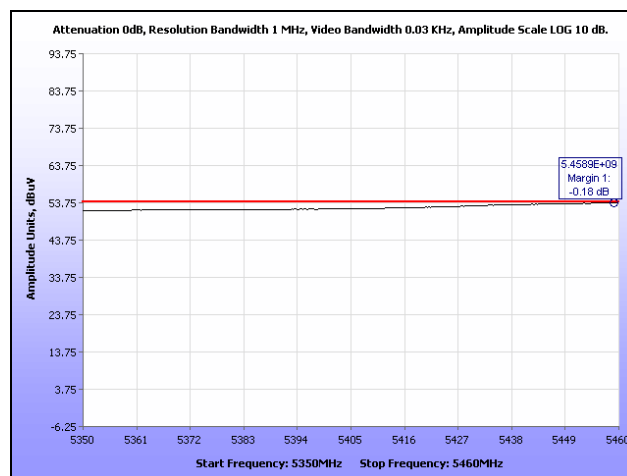

Plot 246. Restricted Band, HT20, High Channel

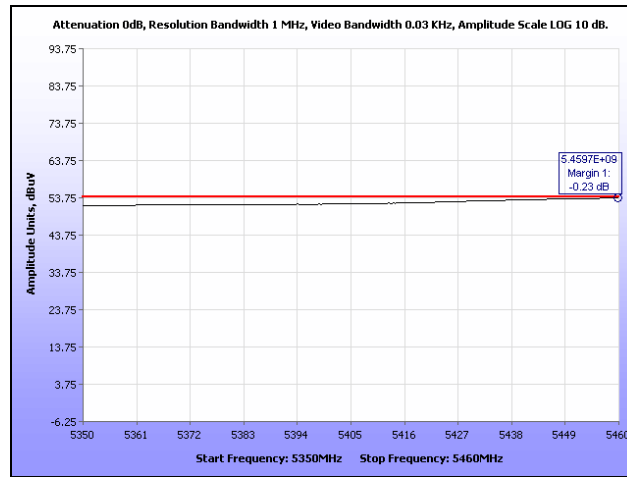

Plot 247. Restricted Band, HT30, Low Channel

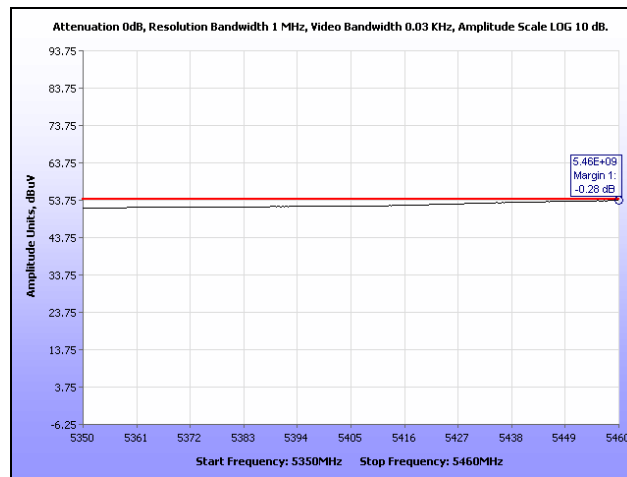

Plot 248. Restricted Band, HT30, Mid Channel

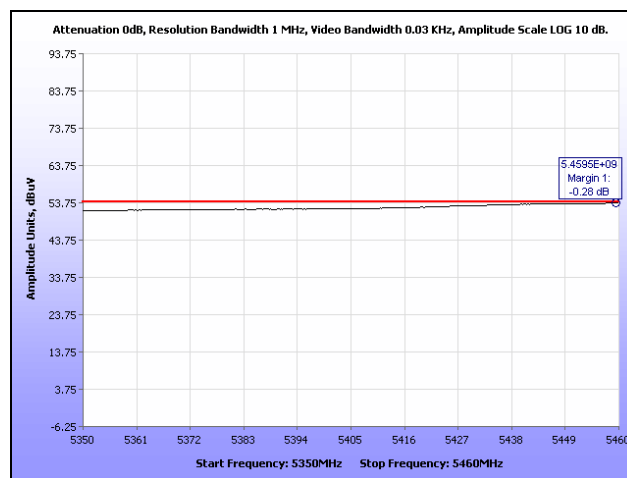

Plot 249. Restricted Band, HT30, High Channel

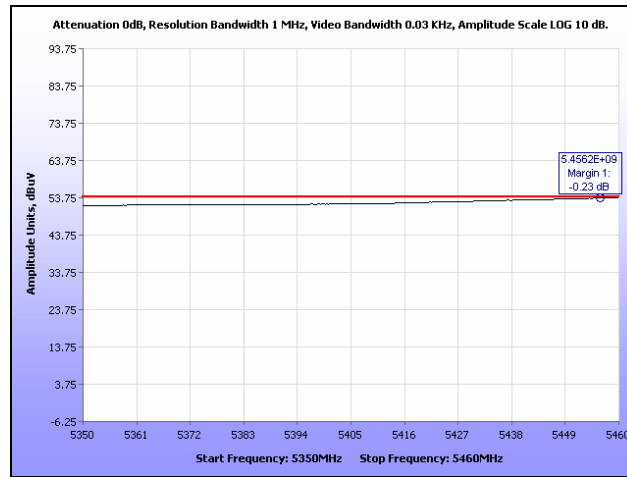

Plot 250. Restricted Band, HT40, Low Channel

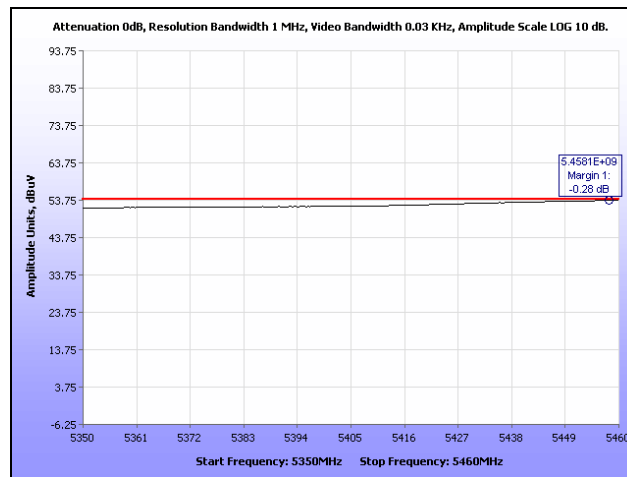

Plot 251. Restricted Band, HT40, Mid Channel

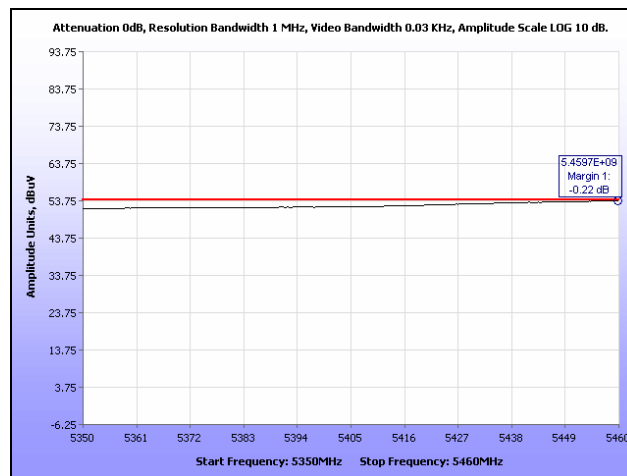

Plot 252. Restricted Band, HT40, High Channel

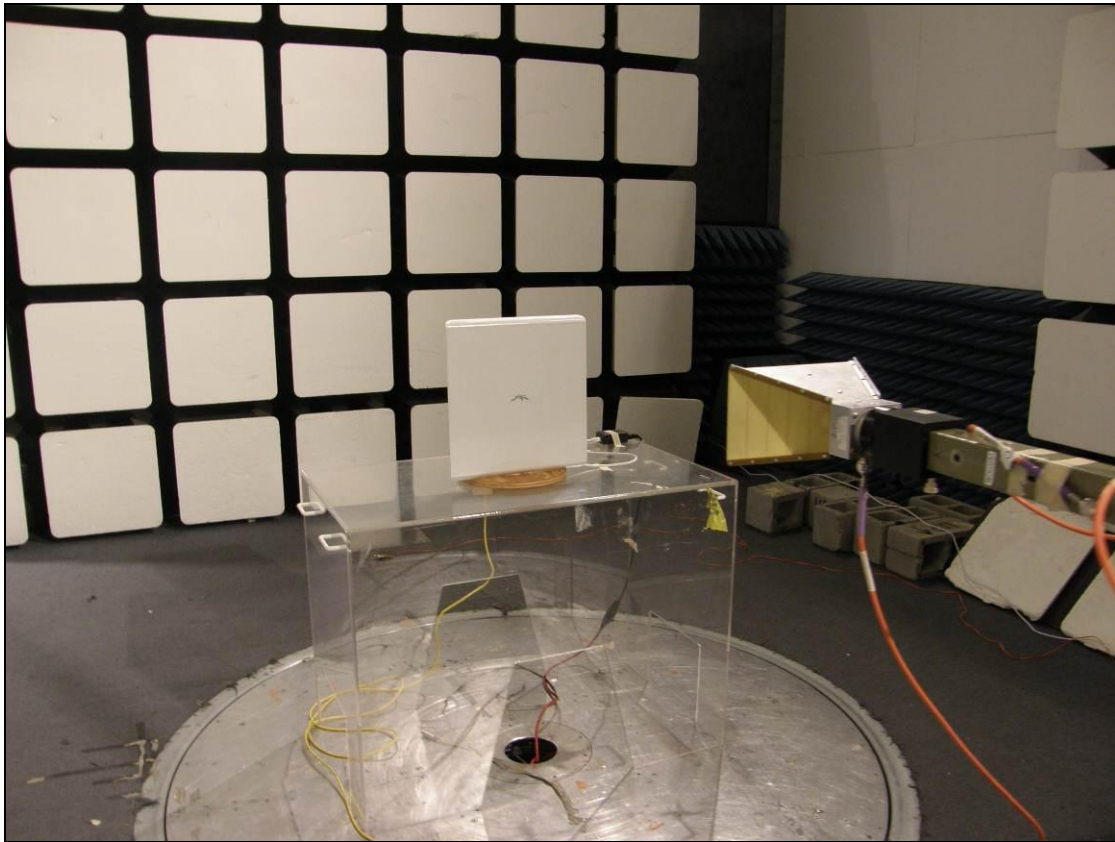

Photograph 5. Radiated Spurious Emissions, Test Setup



Photograph 6. Radiated Spurious Emissions, Test Setup, 30 MHz – 1 GHz

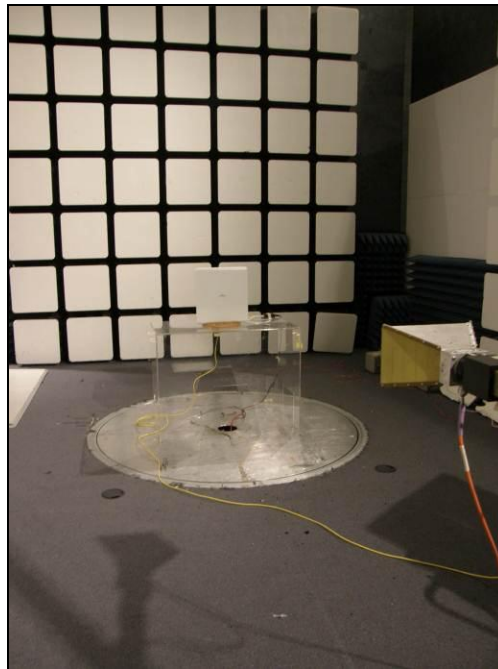

Photograph 7. Radiated Spurious Emissions, Test Setup, 1 GHz – 18 GHz

Electromagnetic Compatibility Criteria for Intentional Radiators

§ 15.247(d) RF Conducted Spurious Emissions Requirements and Band Edge

Test Requirement: **15.247(d)** In any 100 kHz bandwidth outside the frequency band in which the spread spectrum or digitally modulated intentional radiator is operating, the radio frequency power that is produced by the intentional radiator shall be at least 20 dB below that in the 100 kHz bandwidth within the band that contains the highest level of the desired power, based on either an RF conducted or a radiated measurement, provided the transmitter demonstrates compliance with the peak conducted power limits. If the transmitter complies with the conducted power limits based on the use of RMS averaging over a time interval, as permitted under paragraph (b)(3) of this section, the attenuation required under this paragraph shall be 30 dB instead of 20 dB.

Test Procedure: For intentional radiators with a digital device portion which operates below 10 GHz, the spectrum was investigated as per §15.33(a)(1) and §15.33(a)(4); i.e., the lowest RF signal generated or used in the device up to the 10th harmonic of the highest fundamental frequency or to 40 GHz, whichever is lower.

Since the EUT had an integral antenna, conducted measurements could not be performed. Measurements needed to be taken radiated. An antenna was located 3 m away from the EUT and plots were taken. The EUT was rotated through all three orthogonal axes. The plots were corrected for both antenna correction factor and cable loss.

See following pages for detailed test results with RF Conducted Spurious Emissions.

Test Results: The EUT was compliant with the Conducted Spurious Emission limits of **§15.247(d)**.

Test Engineer(s): Lionel Gabrillo

Test Date(s): 05/11/11

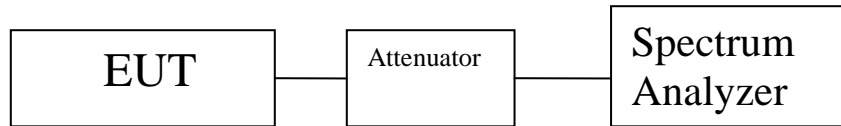
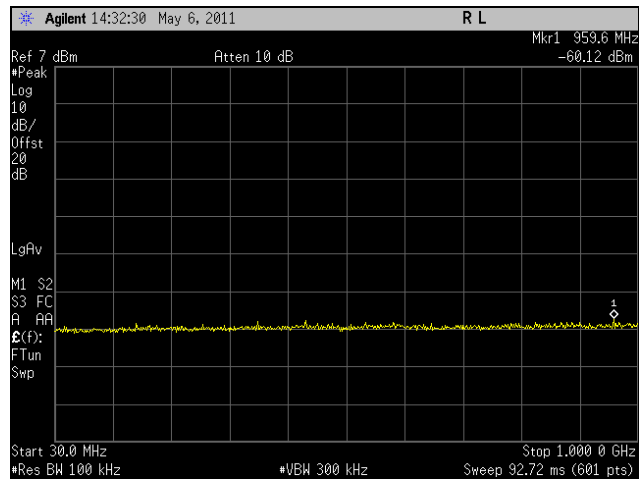
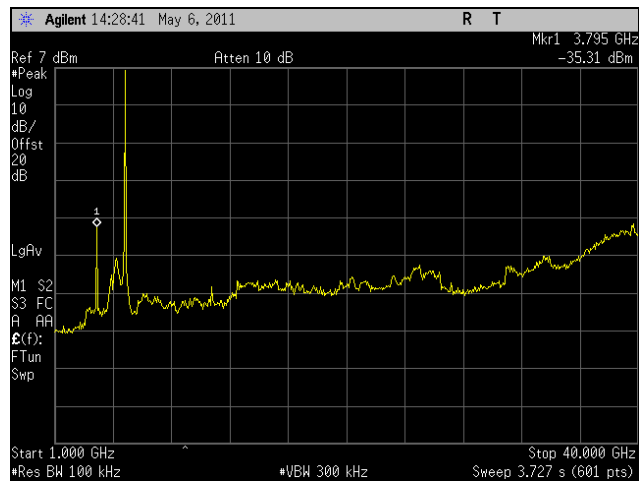

Figure 4. Block Diagram, Conducted Spurious Emissions Test Setup

Conducted Spurious Emissions Test Results, 802.11a 20 MHz



Plot 253. Conducted Spurious, Low Channel, 802.11a 20 MHz, 30 MHz - 1 GHz



Plot 254. Conducted Spurious, Low Channel, 802.11a 20 MHz, 1 GHz - 40 GHz

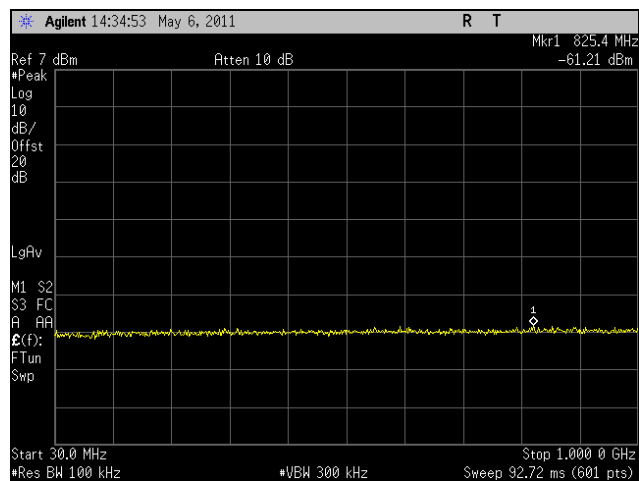

Plot 255. Conducted Spurious, Mid Channel, 802.11a 20 MHz, 30 MHz - 1 GHz

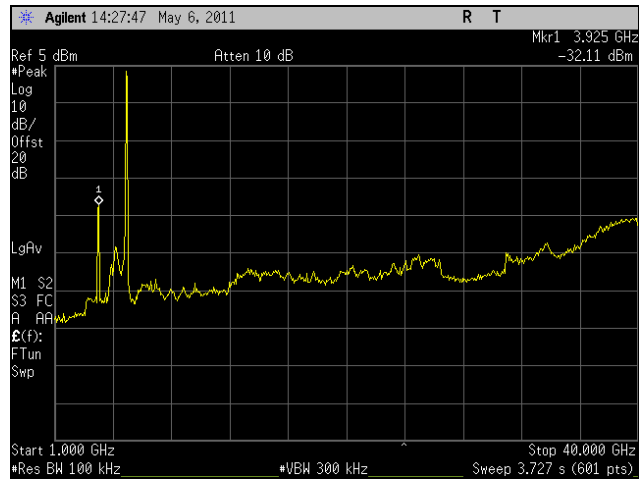

Plot 256. Conducted Spurious, Mid Channel, 802.11a 20 MHz, 1 GHz - 40 GHz

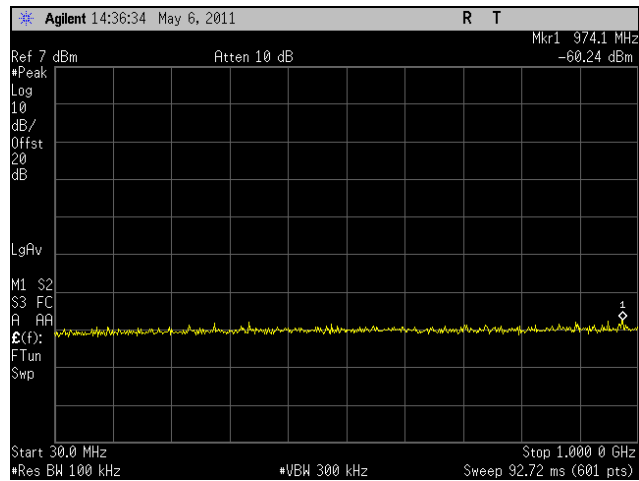

Plot 257. Conducted Spurious, High Channel, 802.11a 20 MHz, 30 MHz - 1 GHz

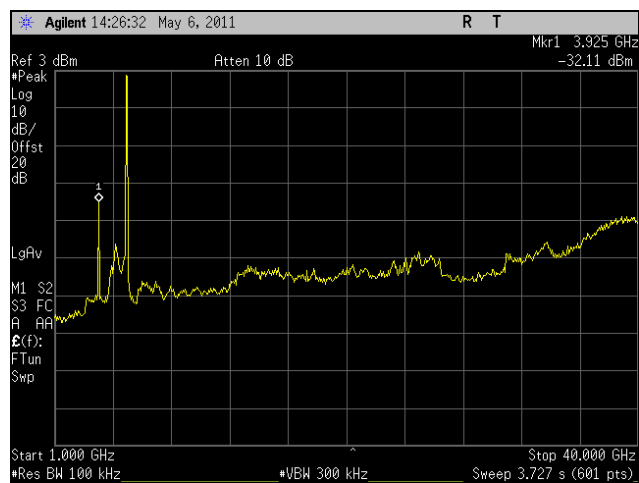

Plot 258. Conducted Spurious, High Channel, 802.11a 20 MHz, 1 GHz - 40 GHz

Conducted Spurious Emissions Test Results, 802.11a 40 MHz

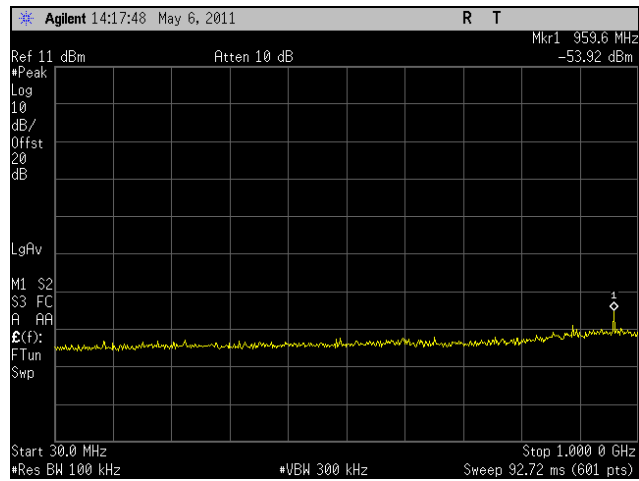

Plot 259. Conducted Spurious, Low Channel, 802.11a 40 MHz, 30 MHz - 1 GHz

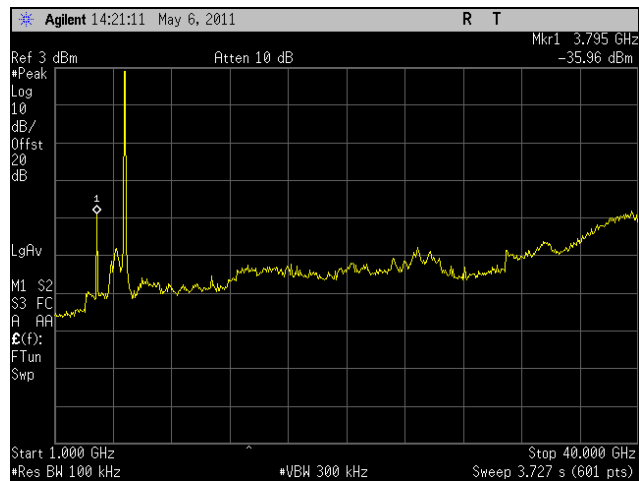

Plot 260. Conducted Spurious, Low Channel, 802.11a 40 MHz, 1 GHz - 40 GHz

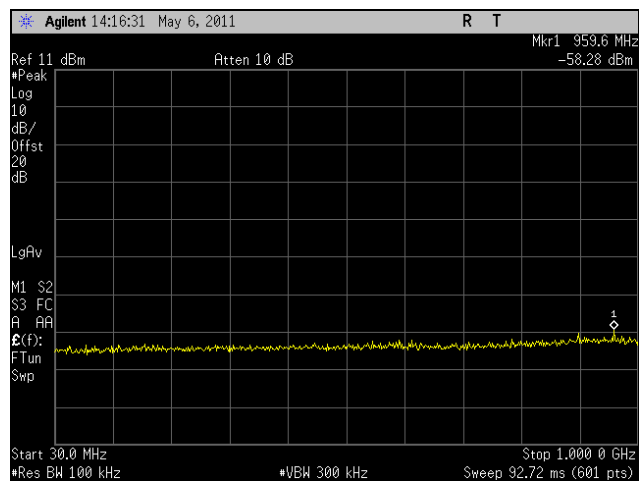

Plot 261. Conducted Spurious, Mid Channel, 802.11a 40 MHz, 30 MHz - 1 GHz

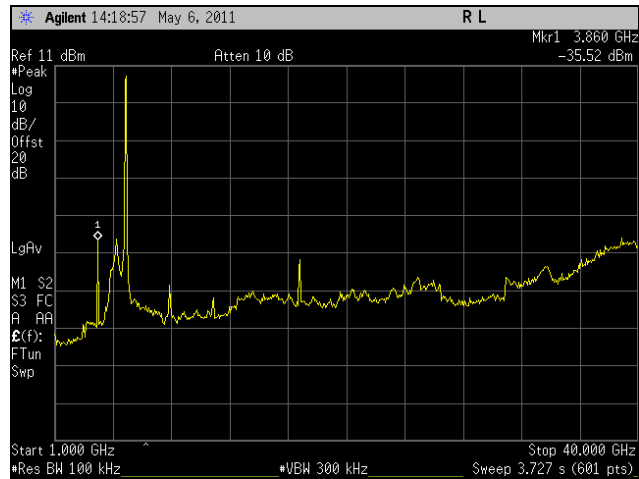

Plot 262. Conducted Spurious, Mid Channel, 802.11a 40 MHz, 1 GHz - 40 GHz

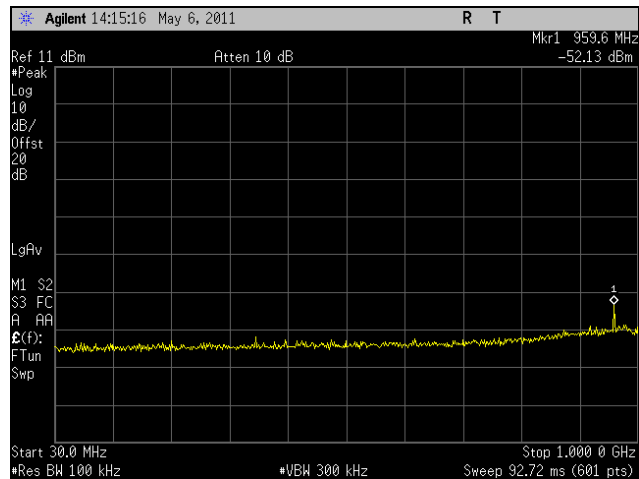

Plot 263. Conducted Spurious, High Channel, 802.11a 40 MHz, 30 MHz - 1 GHz



Plot 264. Conducted Spurious, High Channel, 802.11a 40 MHz, 1 GHz - 40 GHz

Conducted Spurious Emissions Test Results, HT5, Port 1

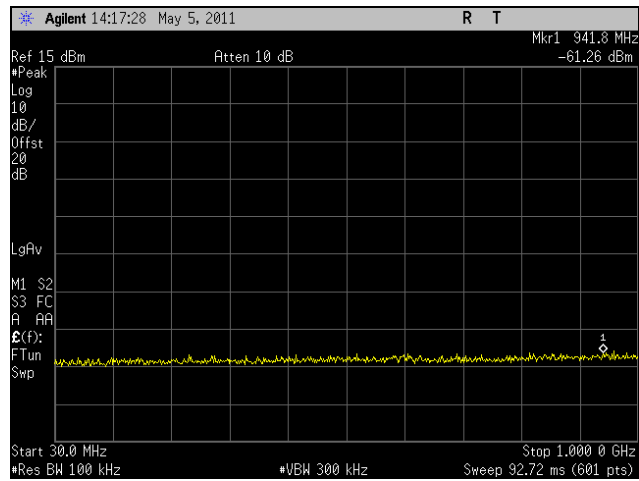

Plot 265. Conducted Spurious, Low Channel, HT5, Port 1, 30 MHz – 1 GHz

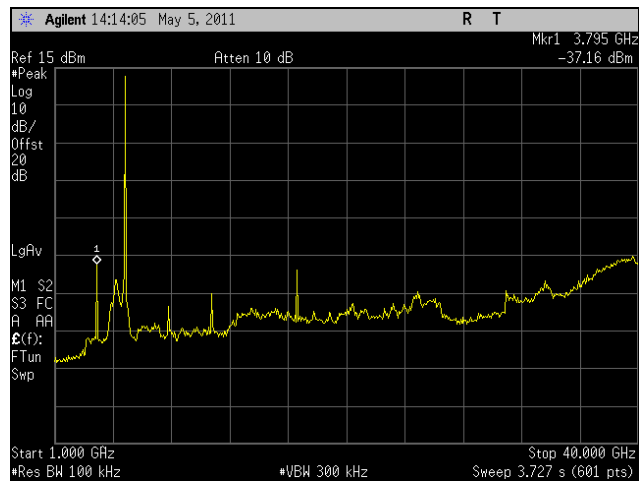

Plot 266. Conducted Spurious, Low Channel, HT5, Port 1, 1 GHz – 40 GHz

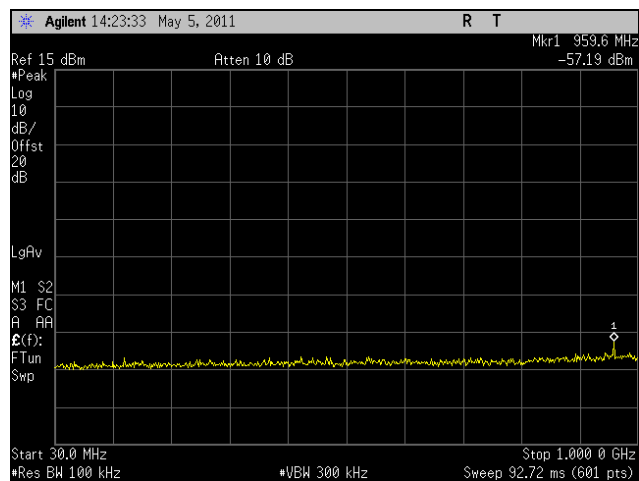

Plot 267. Conducted Spurious, Mid Channel, HT5, Port 1, 30 MHz - 1 GHz

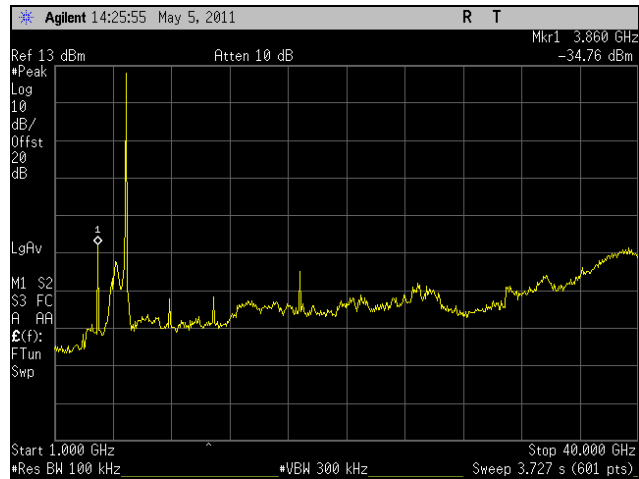

Plot 268. Conducted Spurious, Mid Channel, HT5, Port 1, 1 GHz - 40 GHz

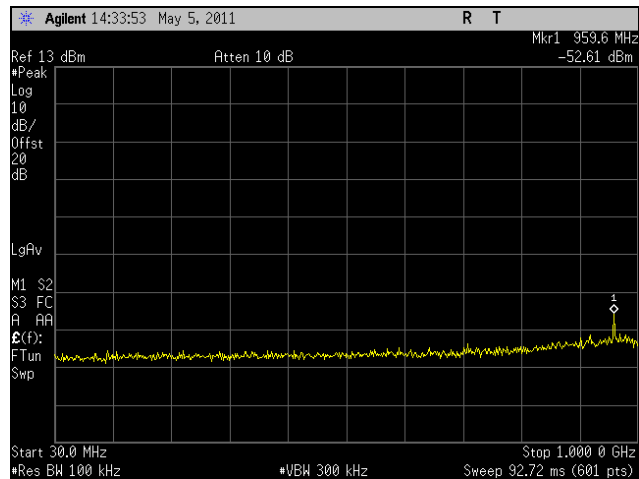

Plot 269. Conducted Spurious, High Channel, HT5, Port 1, 30 MHz - 1 GHz

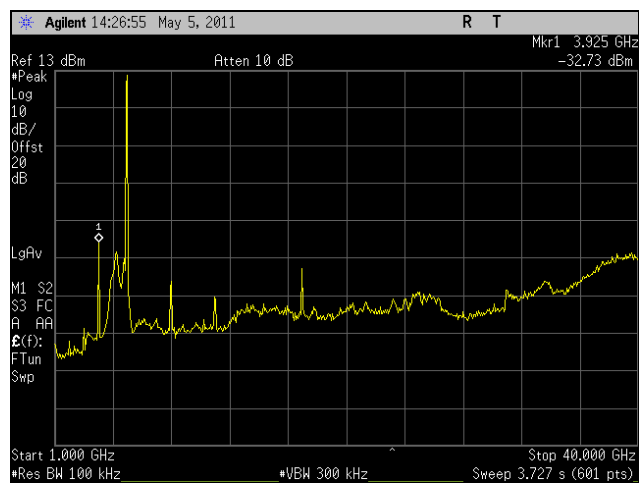

Plot 270. Conducted Spurious, High Channel, HT5, Port 1, 1 GHz - 40 GHz

Conducted Spurious Emissions Test Results, HT5, Port 2

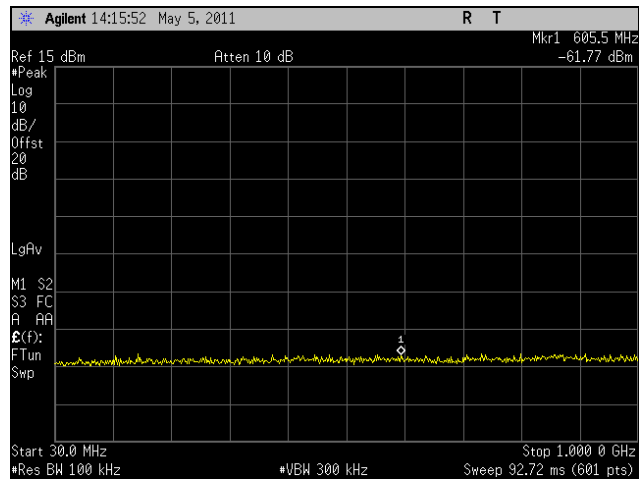

Plot 271. Conducted Spurious, Low Channel, HT5, Port 2, 30 MHz - 1 GHz

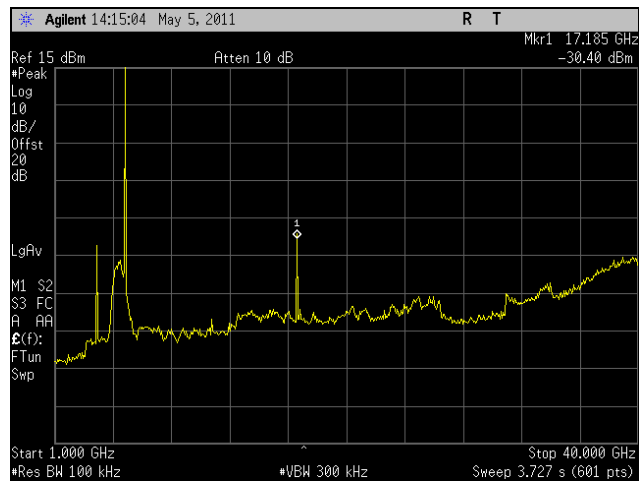

Plot 272. Conducted Spurious, Low Channel, HT5, Port 2, 1 GHz – 40 GHz

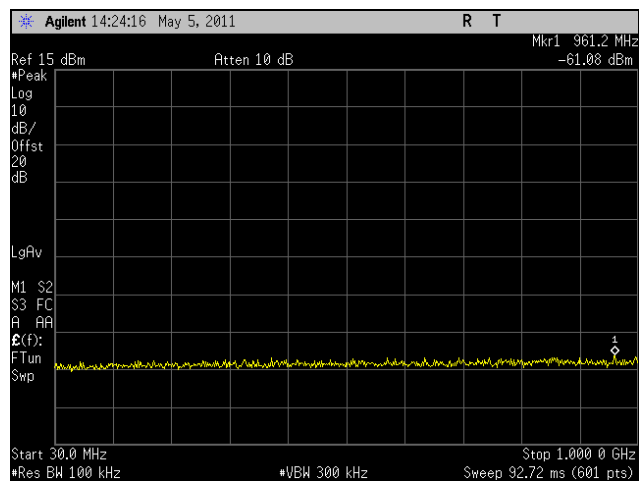

Plot 273. Conducted Spurious, Mid Channel, HT5, Port 2, 30 MHz - 1 GHz

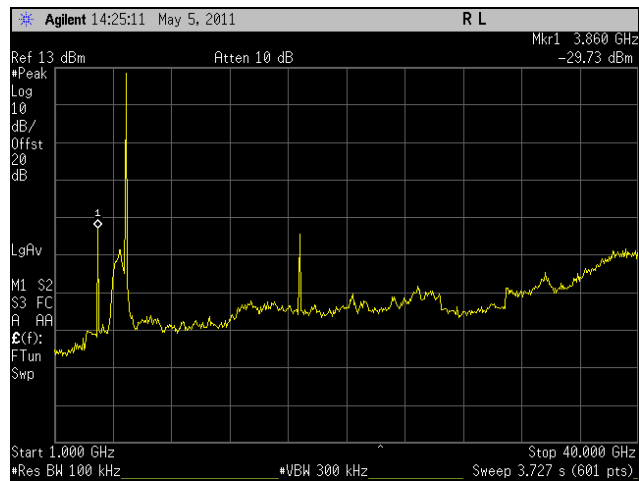

Plot 274. Conducted Spurious, Mid Channel, HT5, Port 2, 1 GHz - 40 GHz

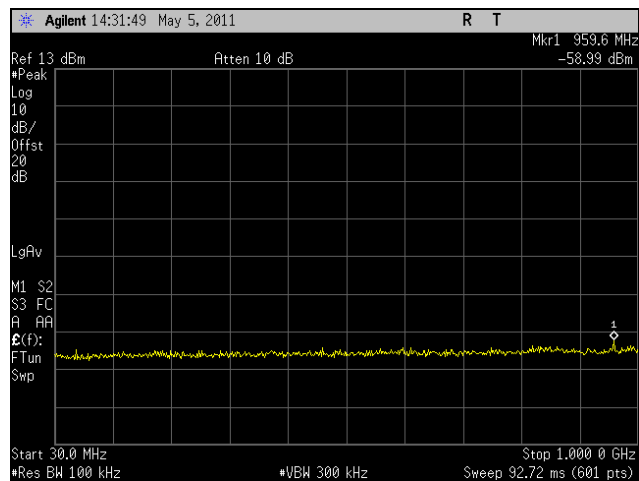

Plot 275. Conducted Spurious, High Channel, HT5, Port 2, 30 MHz - 1 GHz

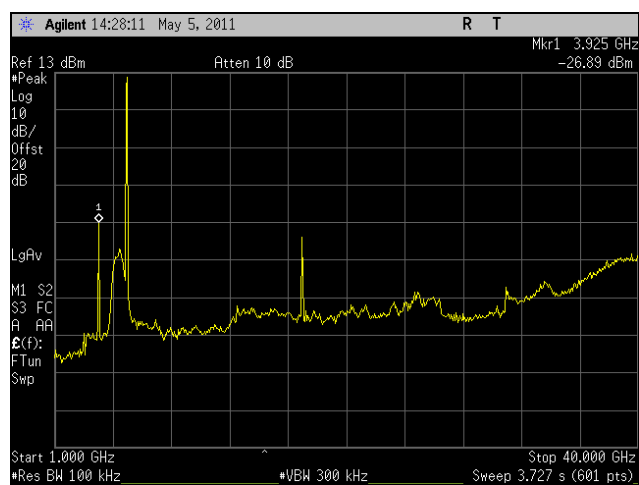

Plot 276. Conducted Spurious, High Channel, HT5, Port 2, 1 GHz - 40 GHz

Conducted Spurious Emissions Test Results, HT8, Port 1

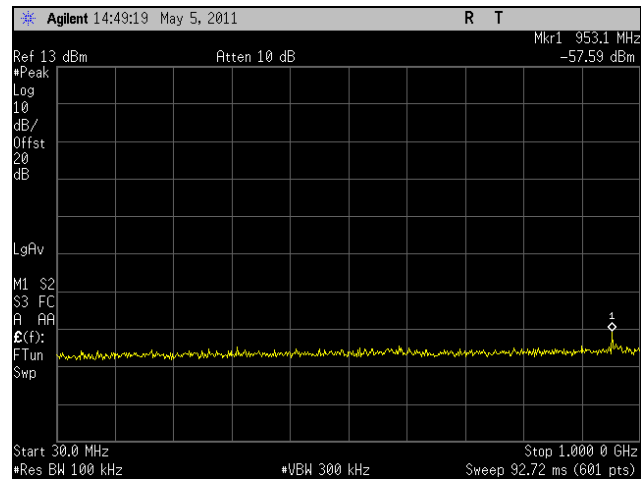

Plot 277. Conducted Spurious, Low Channel, HT8, Port 1, 30 MHz - 1 GHz

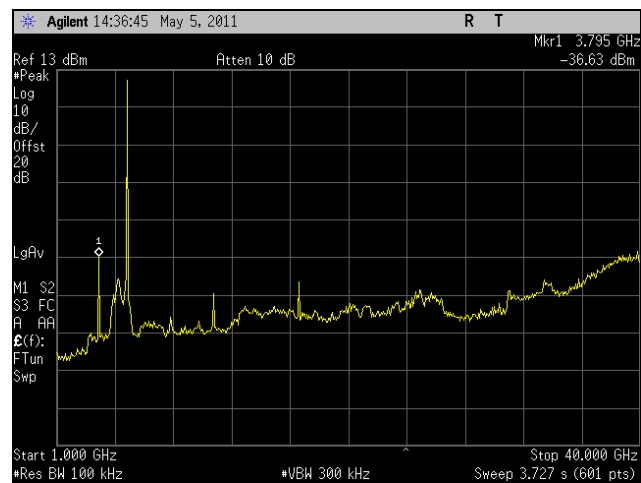

Plot 278. Conducted Spurious, Low Channel, HT8, Port 1, 1 GHz - 40 GHz

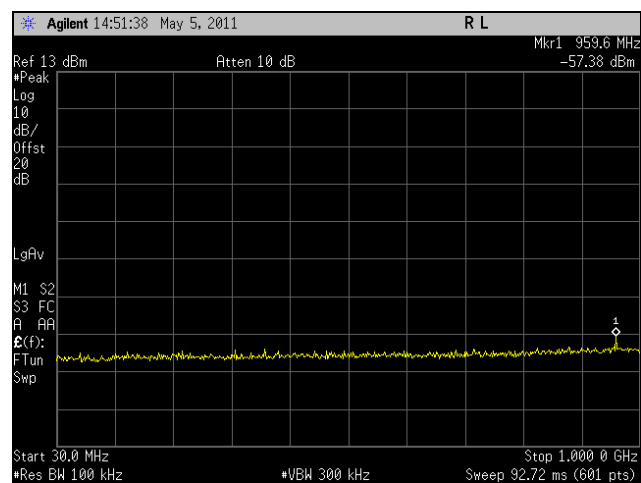

Plot 279. Conducted Spurious, Mid Channel, HT8, Port 1, 30 MHz - 1 GHz

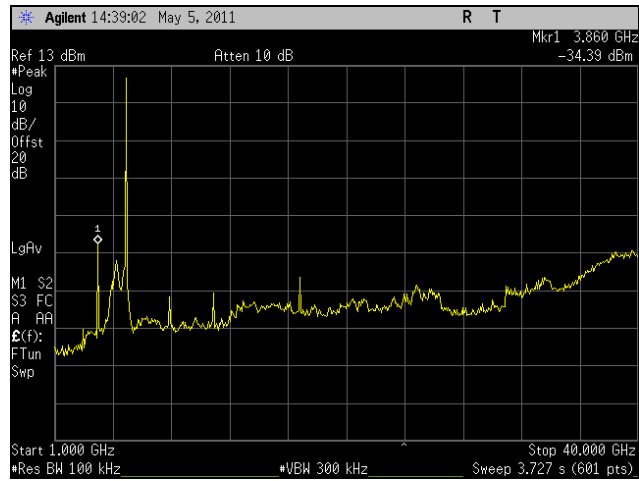

Plot 280. Conducted Spurious, Mid Channel, HT8, Port 1, 1 GHz - 40 GHz

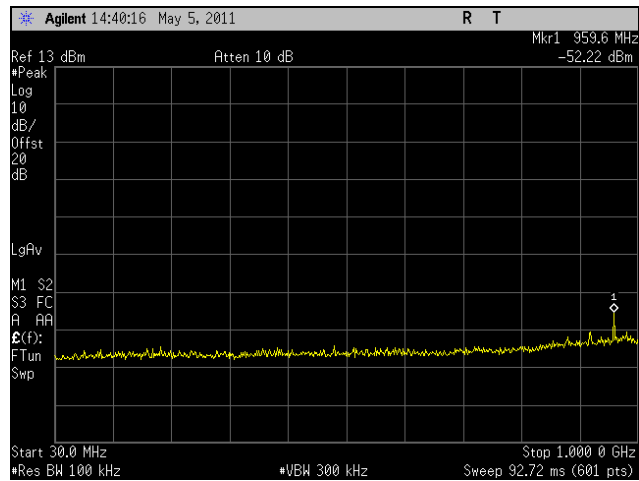

Plot 281. Conducted Spurious, High Channel, HT8, Port 1, 30 MHz - 1 GHz

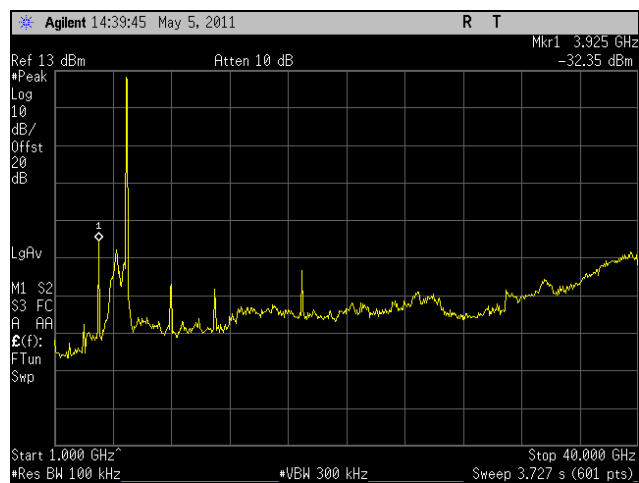

Plot 282. Conducted Spurious, High Channel, HT8, Port 1, 1 GHz - 40 GHz

Conducted Spurious Emissions Test Results, HT8, Port 2

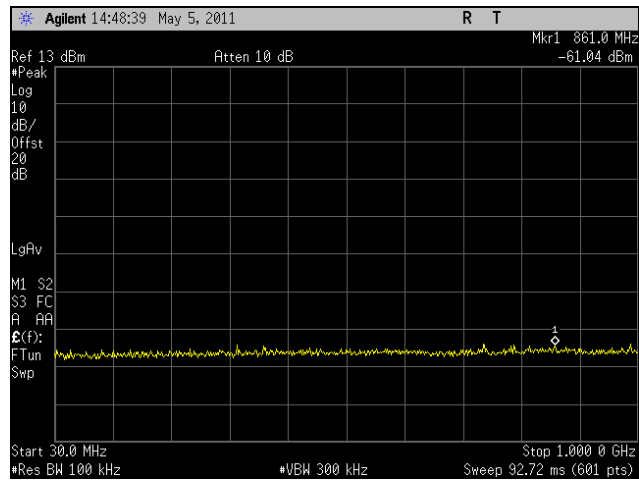

Plot 283. Conducted Spurious, Low Channel, HT8, Port 2, 30 MHz - 1 GHz

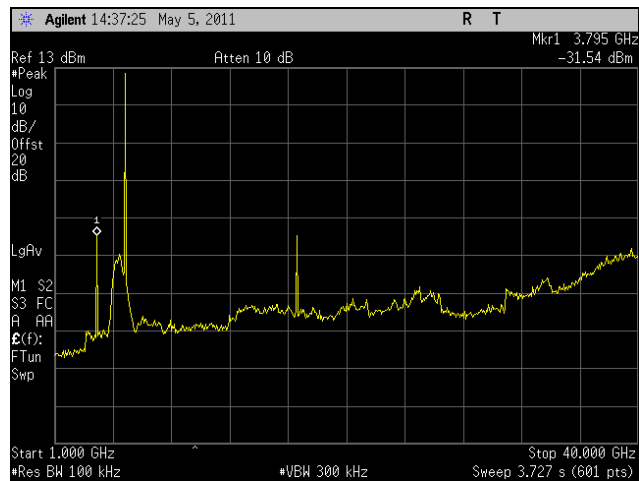

Plot 284. Conducted Spurious, Low Channel, HT8, Port 2, 1 GHz - 40 GHz

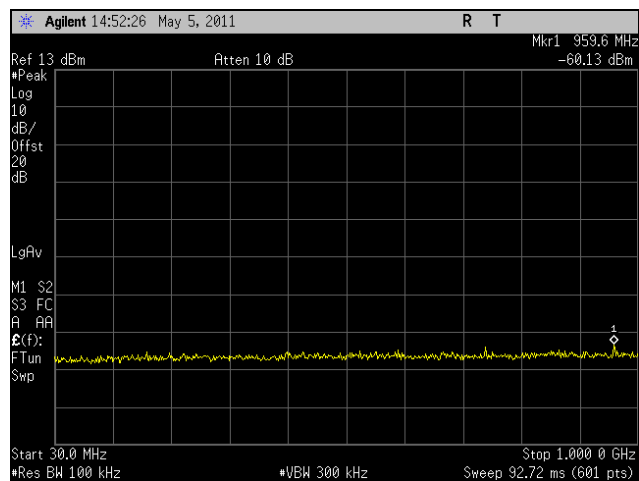

Plot 285. Conducted Spurious, Mid Channel, HT8, Port 2, 30 MHz - 1 GHz

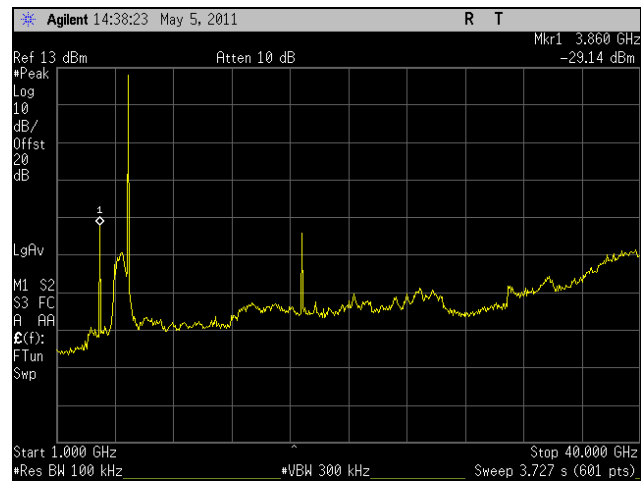

Plot 286. Conducted Spurious, Mid Channel, HT8, Port 2, 1 GHz - 40 GHz

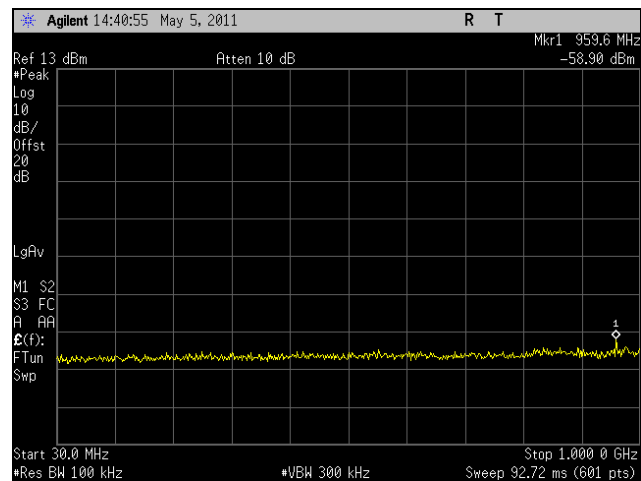

Plot 287. Conducted Spurious, High Channel, HT8, Port 2, 30 MHz - 1 GHz

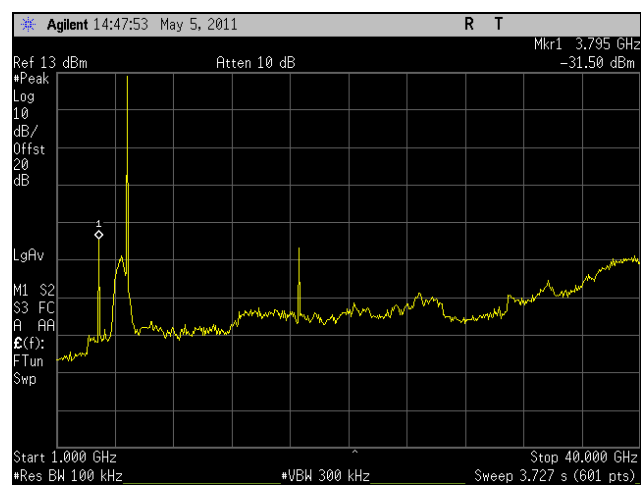

Plot 288. Conducted Spurious, High Channel, HT8, Port 2, 1 GHz - 40 GHz

Conducted Spurious Emissions Test Results, HT10, Port 1

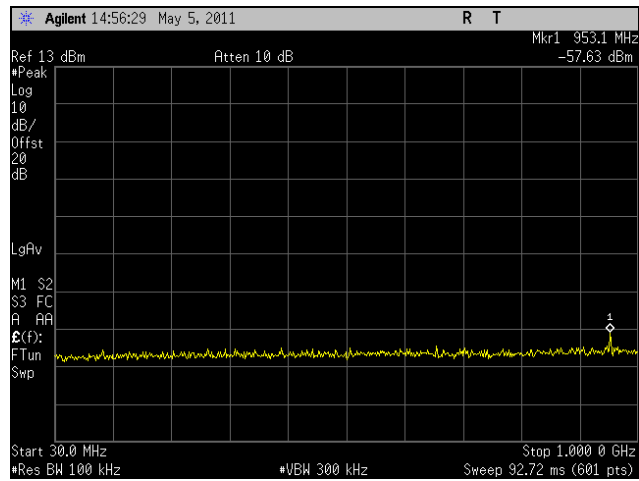

Plot 289. Conducted Spurious, Low Channel, HT10, Port 1, 30 MHz - 1 GHz

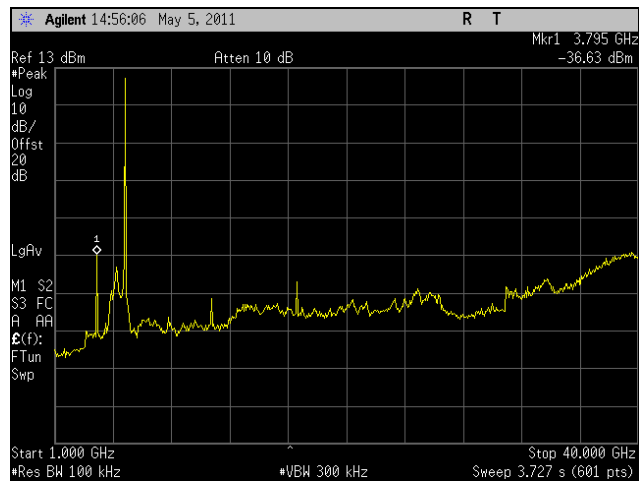

Plot 290. Conducted Spurious, Low Channel, HT10, Port 1, 1 GHz - 40 GHz

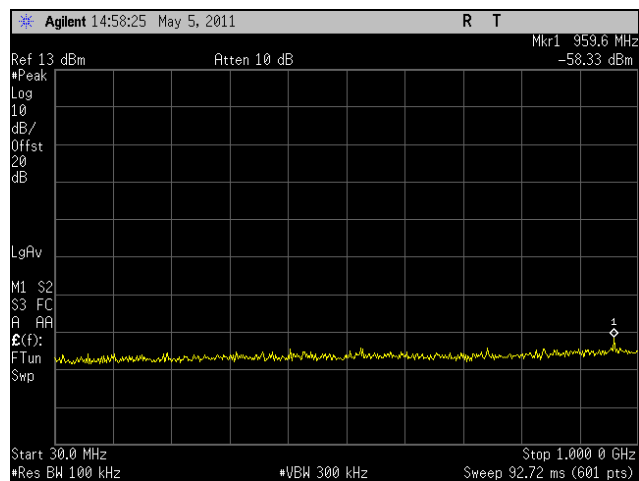

Plot 291. Conducted Spurious, Mid Channel, HT10, Port 1, 30 MHz - 1 GHz

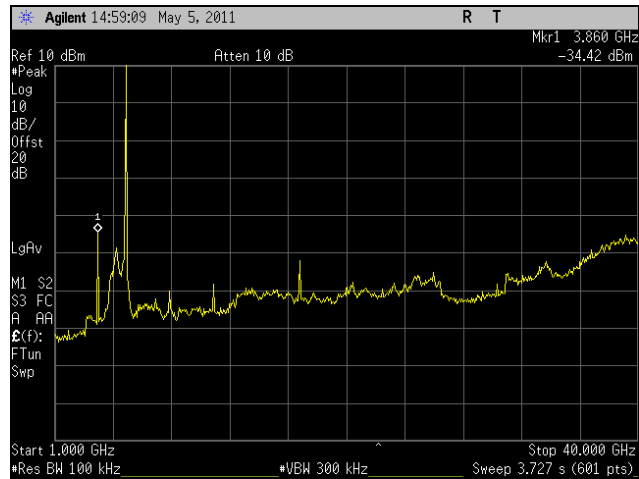

Plot 292. Conducted Spurious, Mid Channel, HT10, Port 1, 1 GHz - 40 GHz

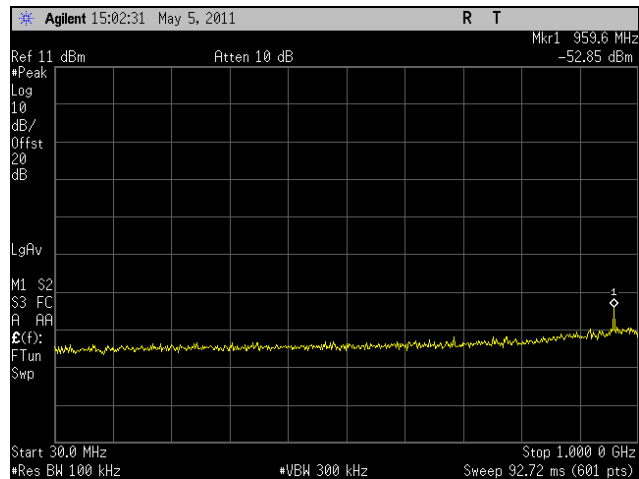

Plot 293. Conducted Spurious, High Channel, HT10, Port 1, 30 MHz - 1 GHz

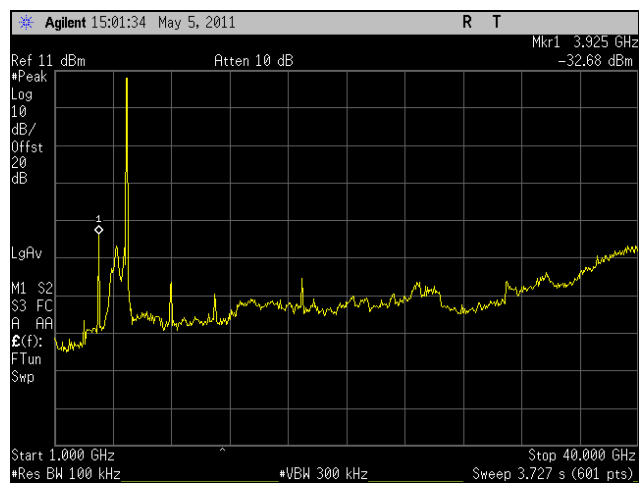

Plot 294. Conducted Spurious, High Channel, HT10, Port 1, 1 GHz - 40 GHz

Conducted Spurious Emissions Test Results, HT10, Port 2

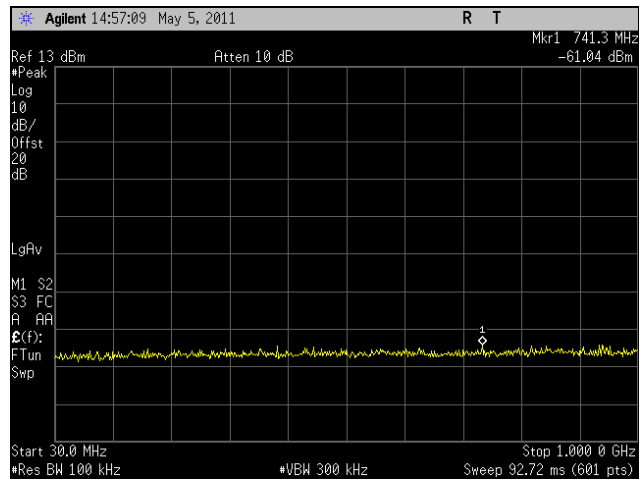

Plot 295. Conducted Spurious, Low Channel, HT10, Port 2, 30 MHz - 1 GHz

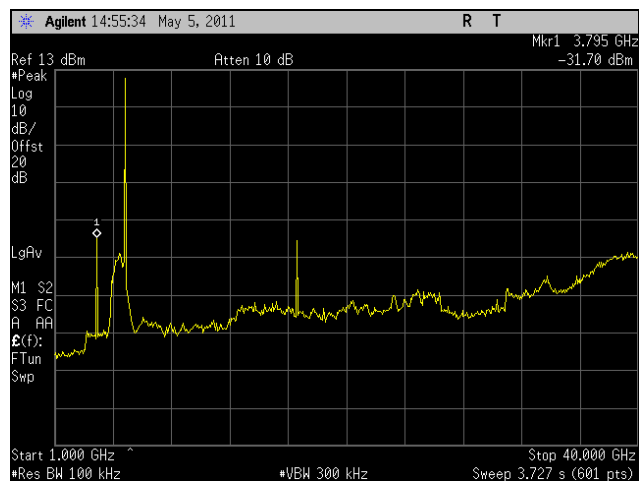

Plot 296. Conducted Spurious, Low Channel, HT10, Port 2, 1 GHz - 40 GHz

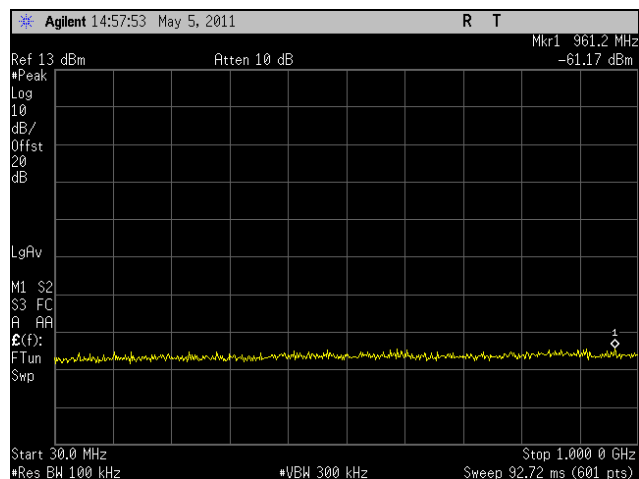

Plot 297. Conducted Spurious, Mid Channel, HT10, Port 2, 30 MHz - 1 GHz

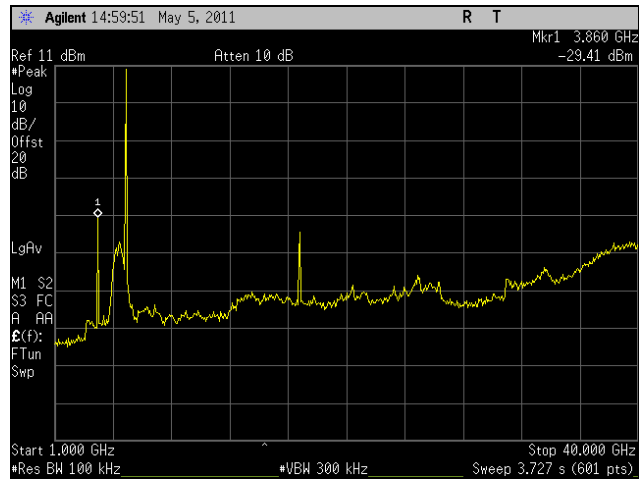

Plot 298. Conducted Spurious, Mid Channel, HT10, Port 2, 1 GHz - 40 GHz

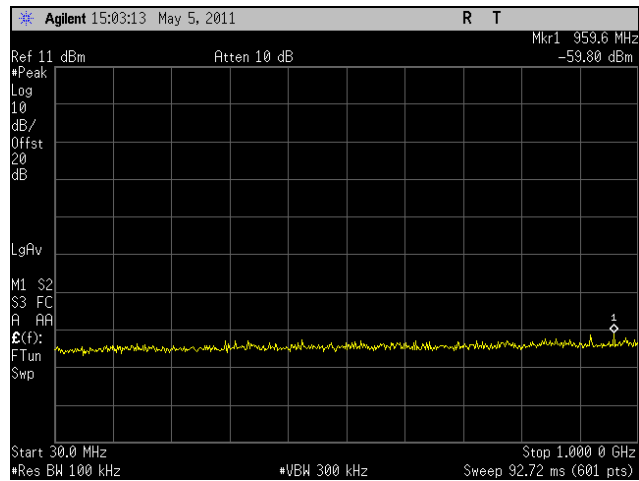

Plot 299. Conducted Spurious, High Channel, HT10, Port 2, 30 MHz - 1 GHz

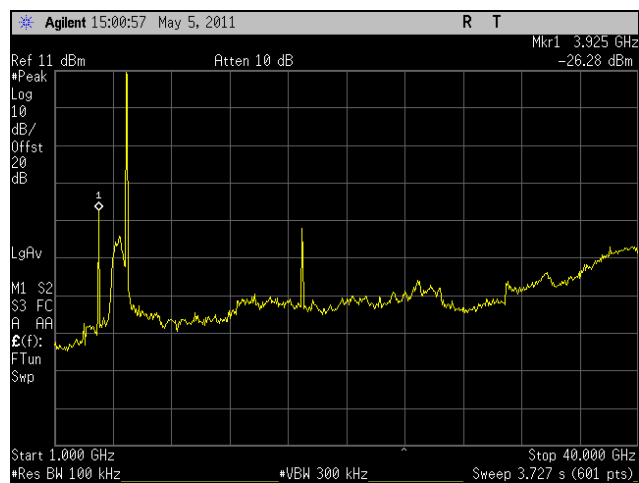

Plot 300. Conducted Spurious, High Channel, HT10, Port 2, 1 GHz - 40 GHz

Conducted Spurious Emissions Test Results, HT20, Port 1

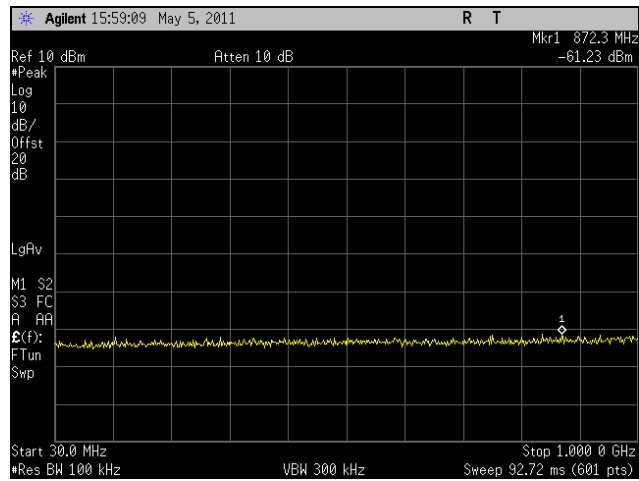

Plot 301. Conducted Spurious, Low Channel, HT20, Port 1, 30 MHz - 1 GHz

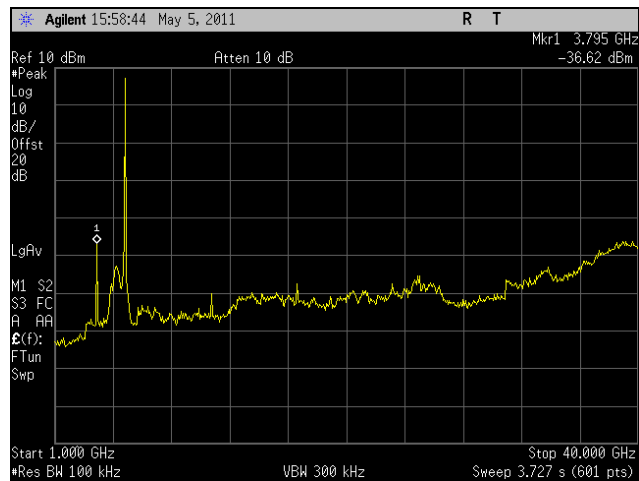

Plot 302. Conducted Spurious, Low Channel, HT20, Port 1, 1 GHz - 40 GHz

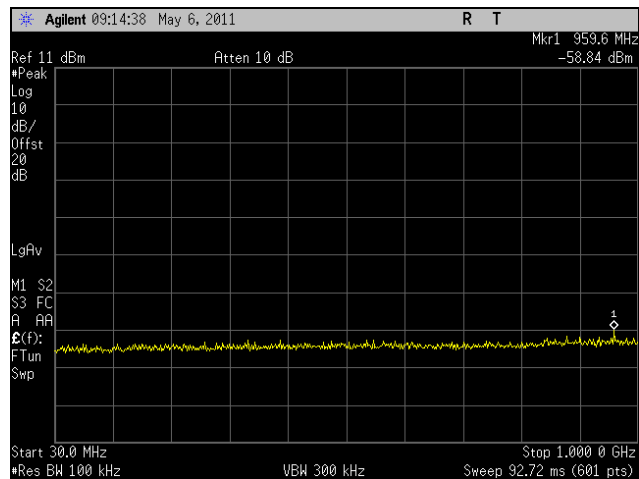

Plot 303. Conducted Spurious, Mid Channel, HT20, Port 1, 30 MHz - 1 GHz

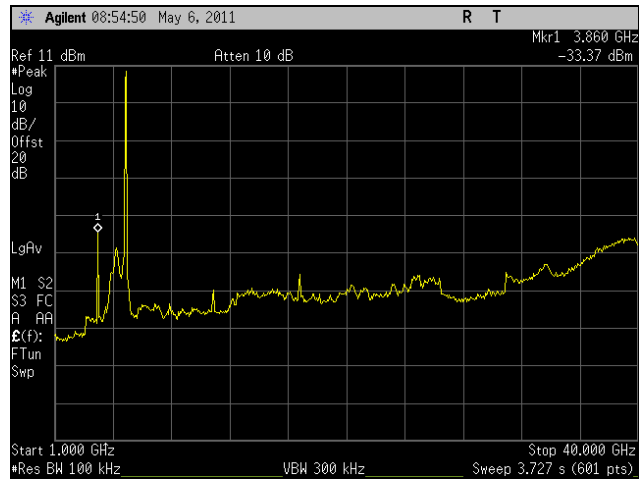

Plot 304. Conducted Spurious, Mid Channel, HT20, Port 1, 1 GHz - 40 GHz

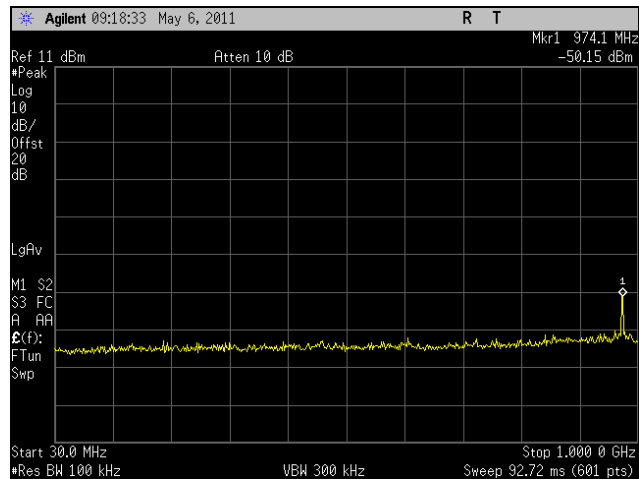

Plot 305. Conducted Spurious, High Channel, HT20, Port 1, 30 MHz - 1 GHz

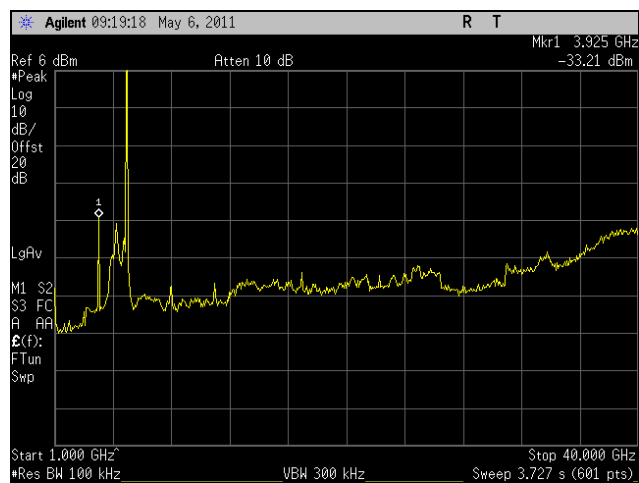

Plot 306. Conducted Spurious, High Channel, HT20, Port 1, 1 GHz - 40 GHz

Conducted Spurious Emissions Test Results, HT20, Port 2

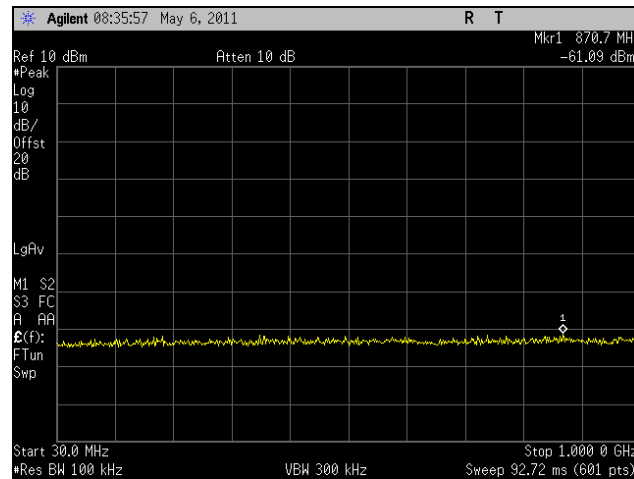

Plot 307. Conducted Spurious, Low Channel, HT20, Port 2, 30 MHz - 1 GHz

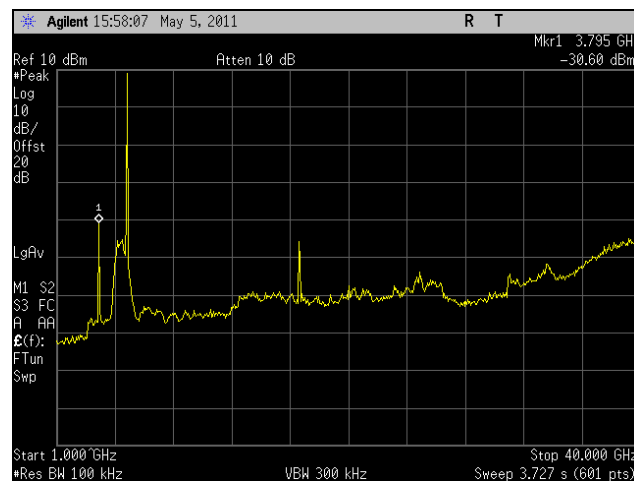

Plot 308. Conducted Spurious, Low Channel, HT20, Port 2, 1 GHz - 40 GHz

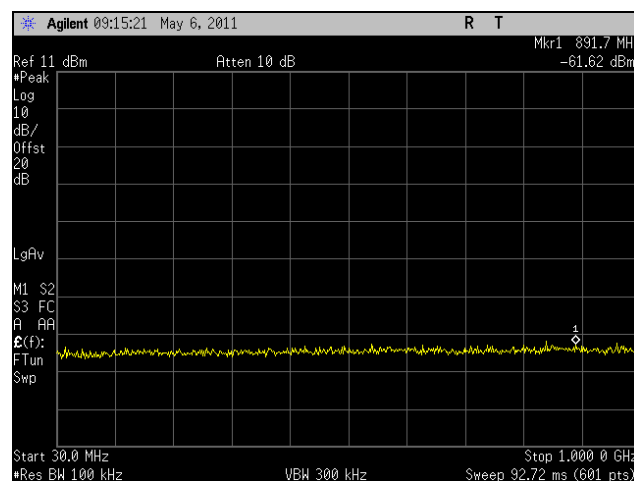

Plot 309. Conducted Spurious, Mid Channel, HT20, Port 2, 30 MHz - 1 GHz

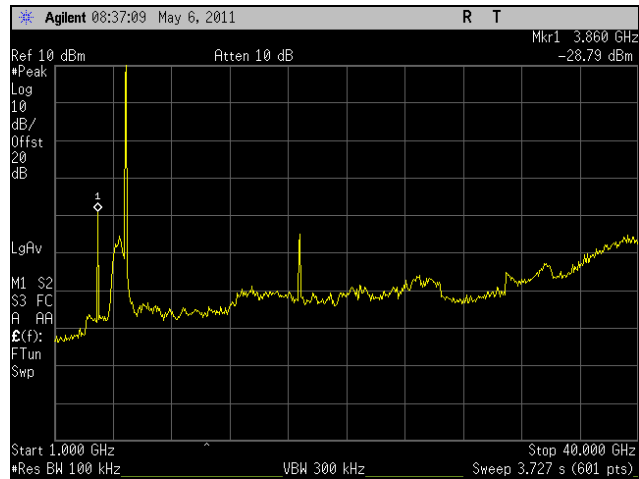

Plot 310. Conducted Spurious, Mid Channel, HT20, Port 2, 1 GHz - 40 GHz

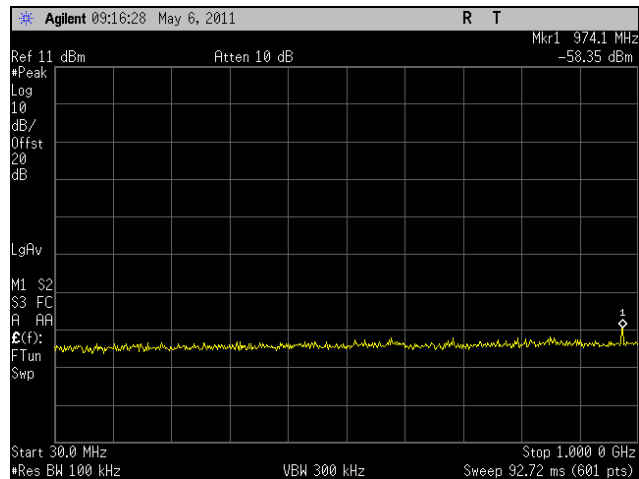

Plot 311. Conducted Spurious, High Channel, HT20, Port 2, 30 MHz - 1 GHz

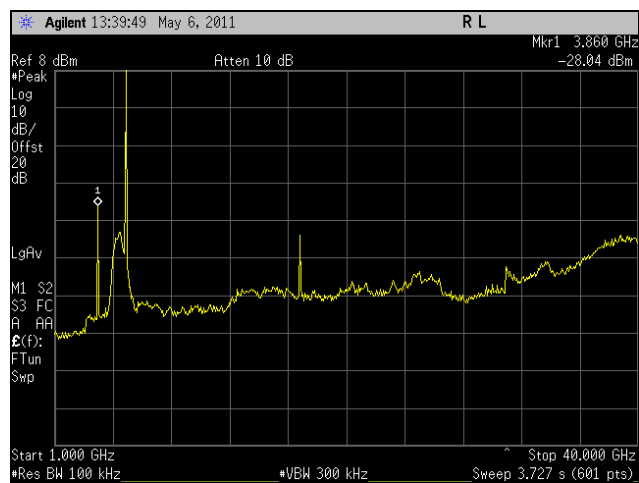

Plot 312. Conducted Spurious, High Channel, HT20, Port 2, 1 GHz - 40 GHz

Conducted Spurious Emissions Test Results, HT30, Port 1

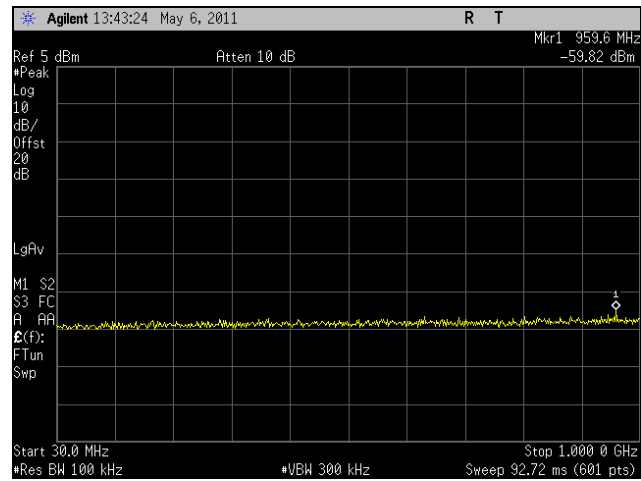

Plot 313. Conducted Spurious, Low Channel, HT30, Port 1, 30 MHz - 1 GHz

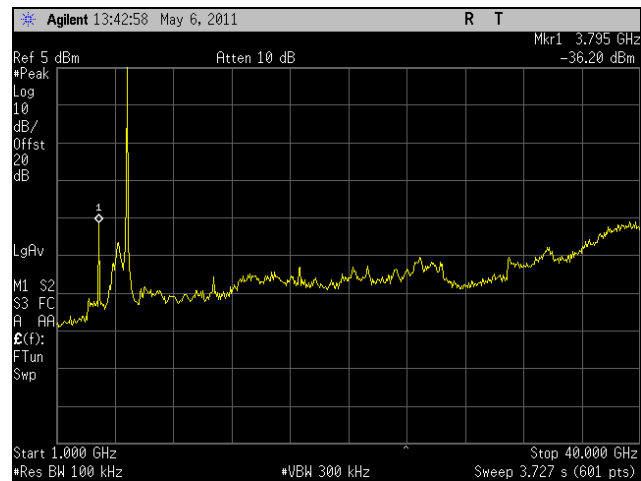

Plot 314. Conducted Spurious, Low Channel, HT30, Port 1, 1 GHz - 40 GHz

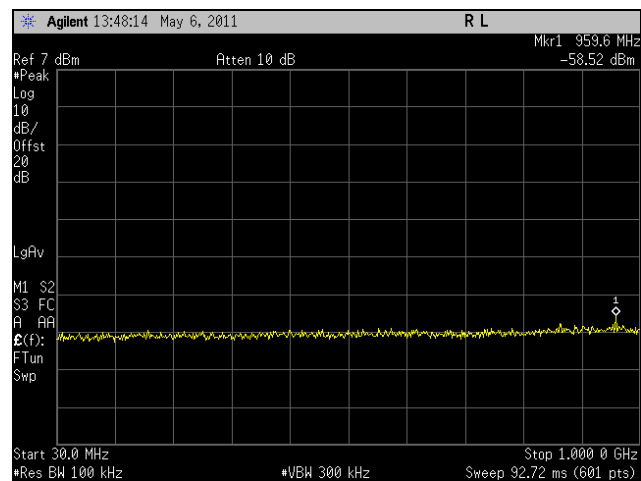

Plot 315. Conducted Spurious, Mid Channel, HT30, Port 1, 30 MHz - 1 GHz

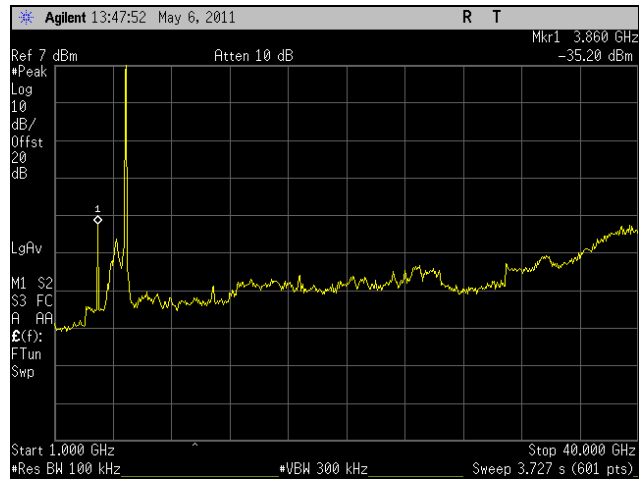

Plot 316. Conducted Spurious, Mid Channel, HT30, Port 1, 1 GHz - 40 GHz

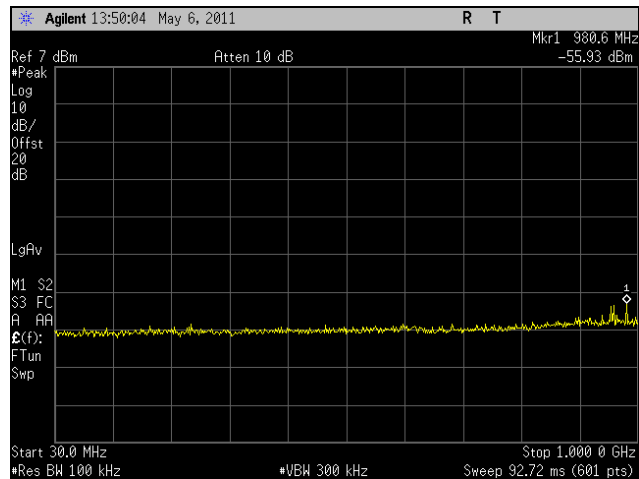

Plot 317. Conducted Spurious, High Channel, HT30, Port 1, 30 MHz - 1 GHz

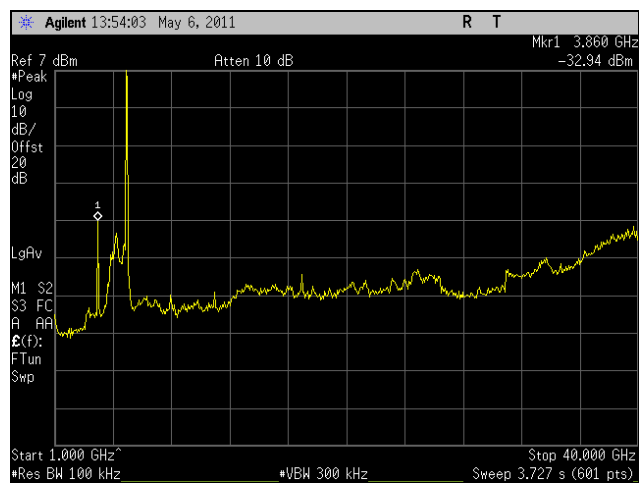

Plot 318. Conducted Spurious, High Channel, HT30, Port 1, 1 GHz - 40 GHz

Conducted Spurious Emissions Test Results, HT30, Port 2

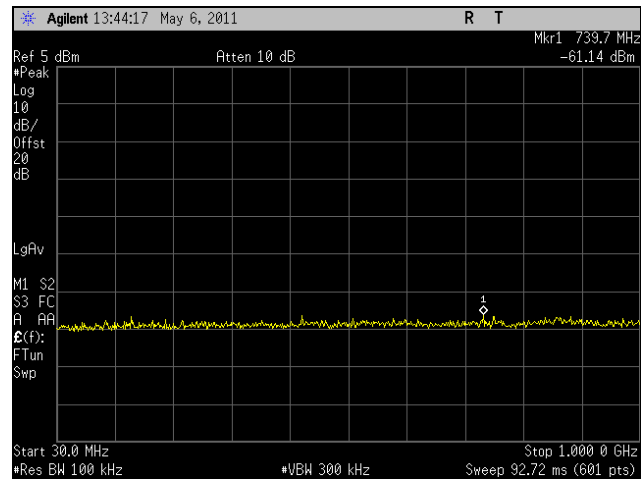

Plot 319. Conducted Spurious, Low Channel, HT30, Port 2, 30 MHz - 1 GHz

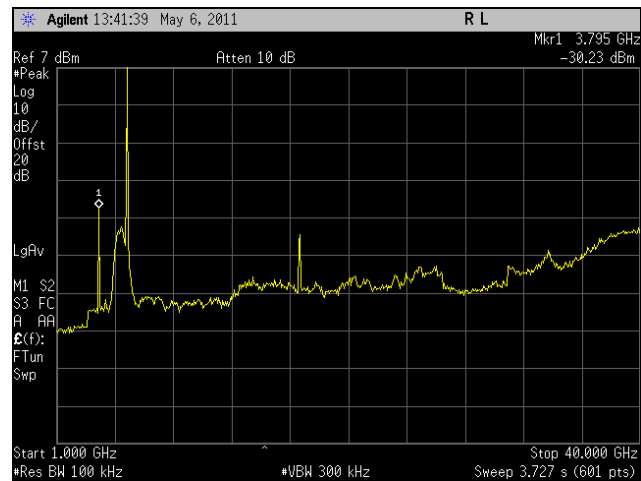

Plot 320. Conducted Spurious, Low Channel, HT30, Port 2, 1 GHz - 40 GHz

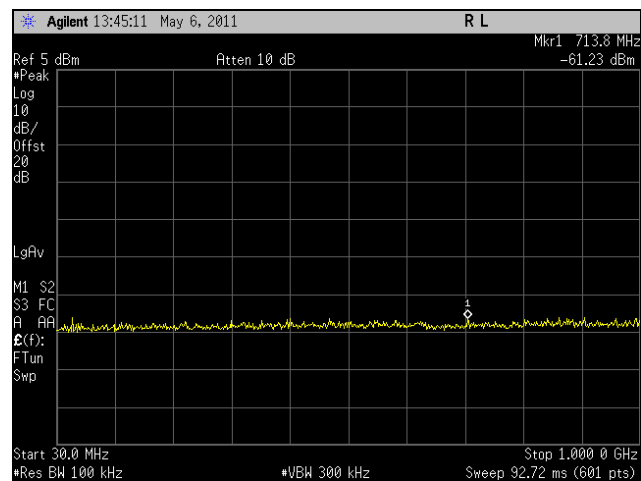

Plot 321. Conducted Spurious, Mid Channel, HT30, Port 2, 30 MHz - 1 GHz

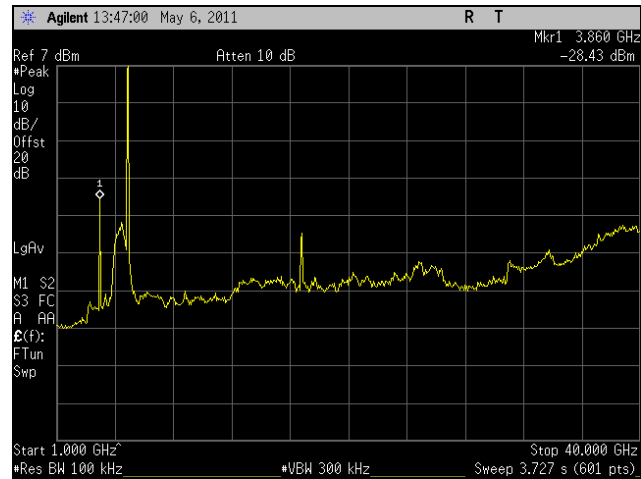

Plot 322. Conducted Spurious, Mid Channel, HT30, Port 2, 1 GHz - 40 GHz

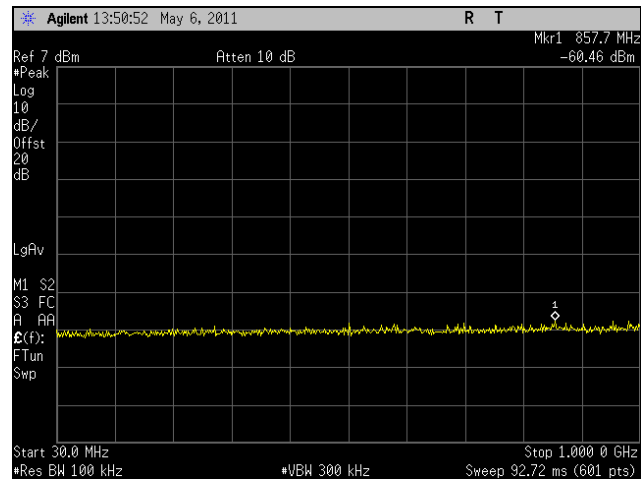

Plot 323. Conducted Spurious, High Channel, HT30, Port 2, 30 MHz - 1 GHz

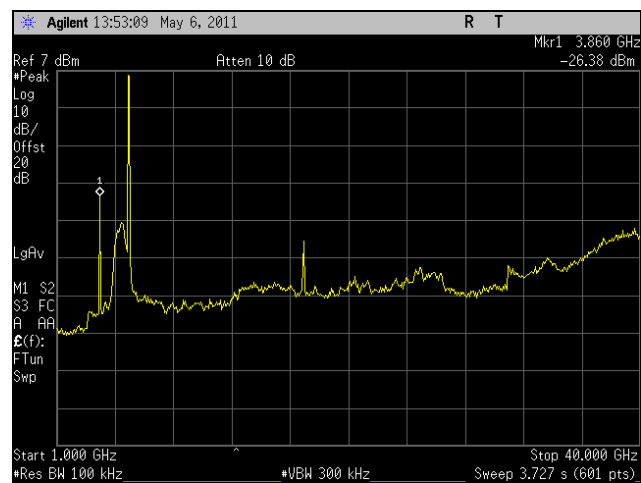

Plot 324. Conducted Spurious, High Channel, HT30, Port 2, 1 GHz - 40 GHz

Conducted Spurious Emissions Test Results, HT40, Port 1

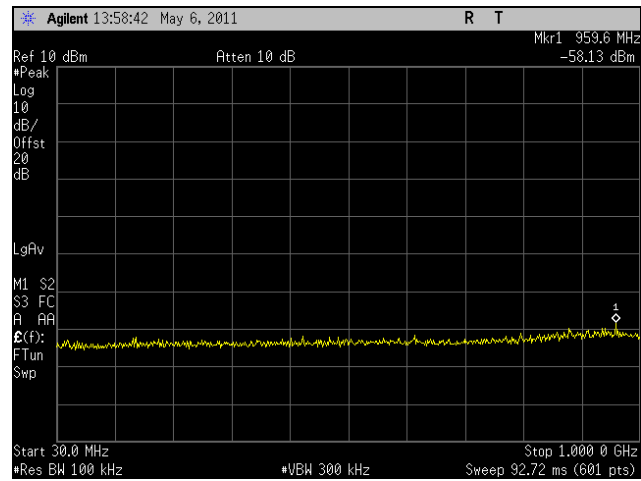

Plot 325. Conducted Spurious, Low Channel, HT40, Port 1, 30 MHz - 1 GHz

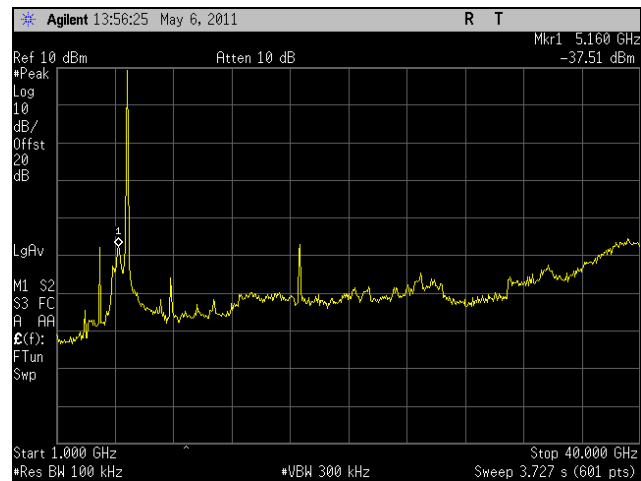

Plot 326. Conducted Spurious, Low Channel, HT40, Port 1, 1 GHz - 40 GHz

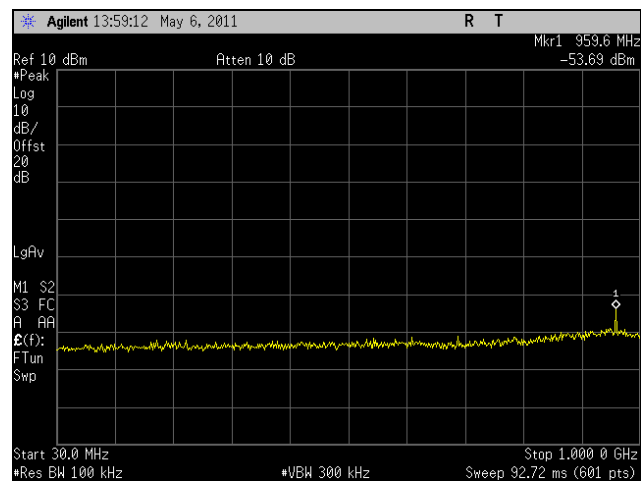

Plot 327. Conducted Spurious, Mid Channel, HT40, Port 1, 30 MHz - 1 GHz

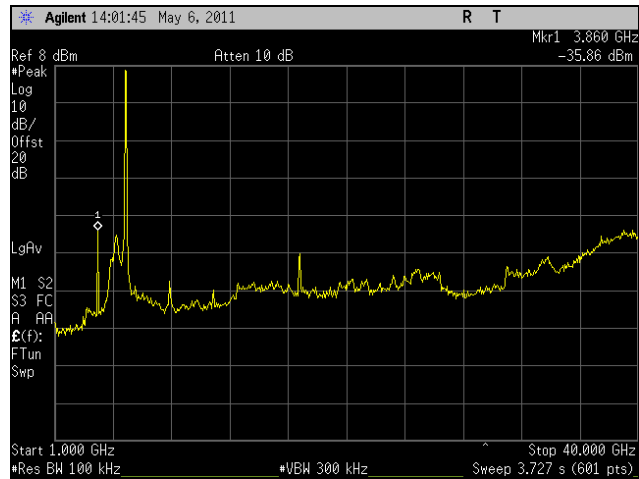

Plot 328. Conducted Spurious, Mid Channel, HT40, Port 1, 1 GHz - 40 GHz

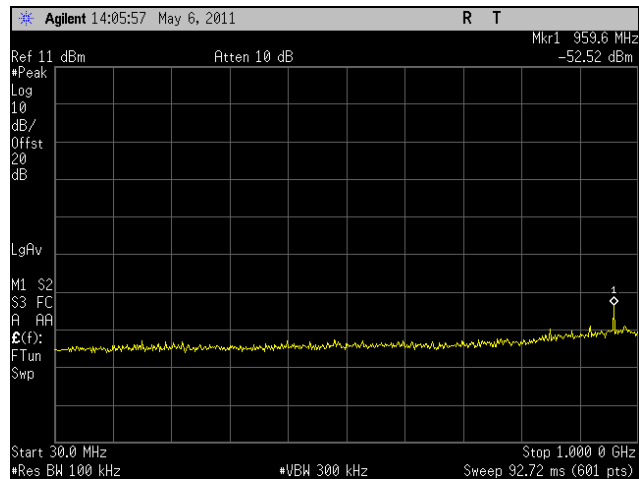

Plot 329. Conducted Spurious, High Channel, HT40, Port 1, 30 MHz - 1 GHz

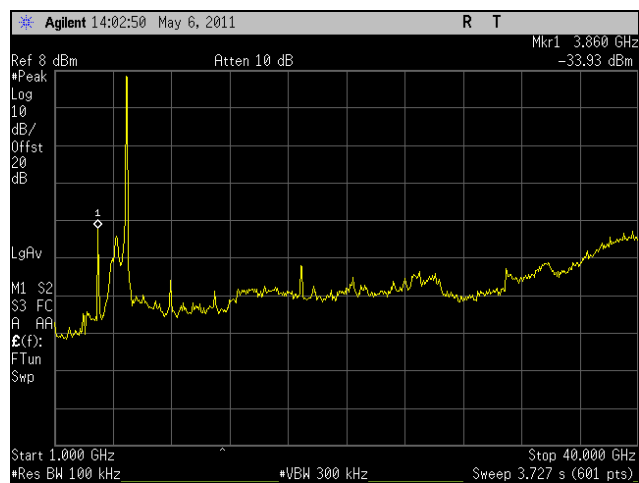

Plot 330. Conducted Spurious, High Channel, HT40, Port 1, 1 GHz - 40 GHz

Conducted Spurious Emissions Test Results, HT40, Port 2

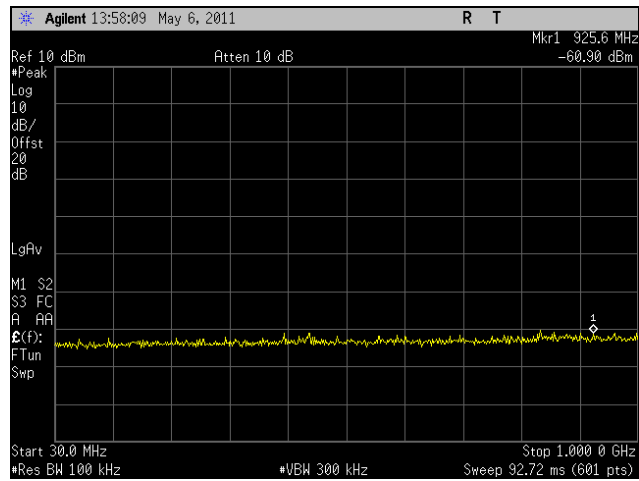

Plot 331. Conducted Spurious, Low Channel, HT40, Port 2, 30 MHz - 1 GHz

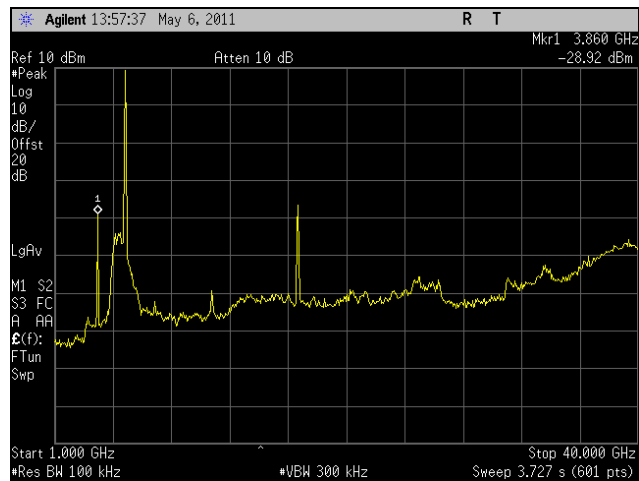

Plot 332. Conducted Spurious, Low Channel, HT40, Port 2, 1 GHz - 40 GHz

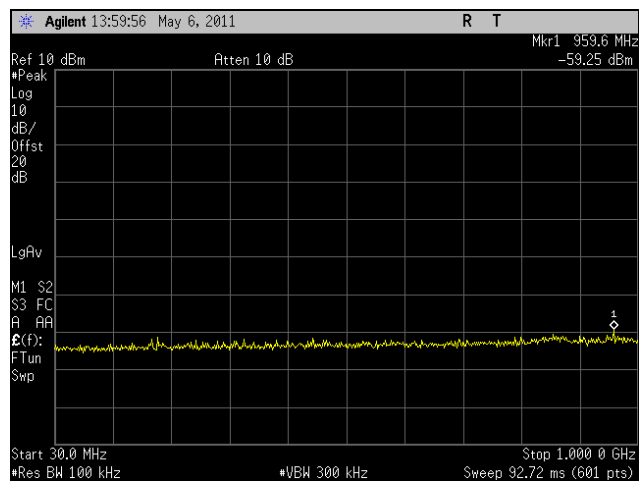

Plot 333. Conducted Spurious, Mid Channel, HT40, Port 2, 30 MHz - 1 GHz

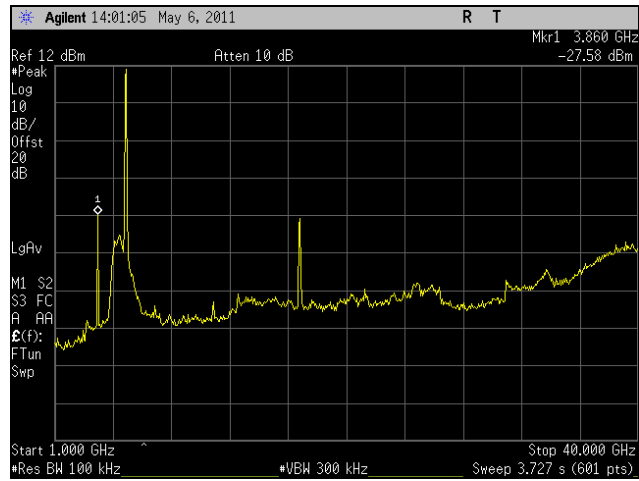

Plot 334. Conducted Spurious, Mid Channel, HT40, Port 2, 1 GHz - 40 GHz

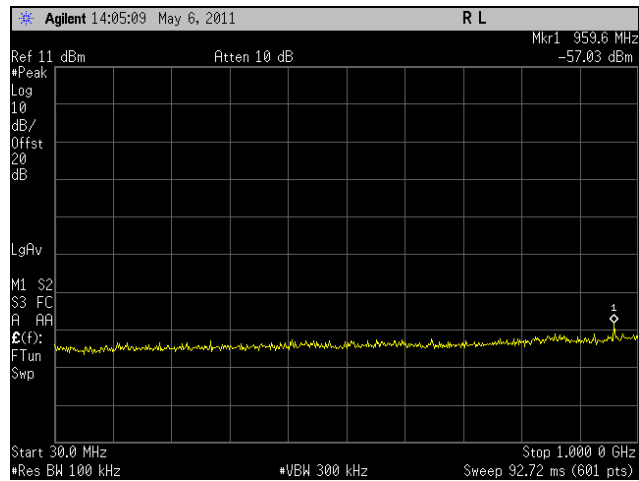

Plot 335. Conducted Spurious, High Channel, HT40, Port 2, 30 MHz - 1 GHz

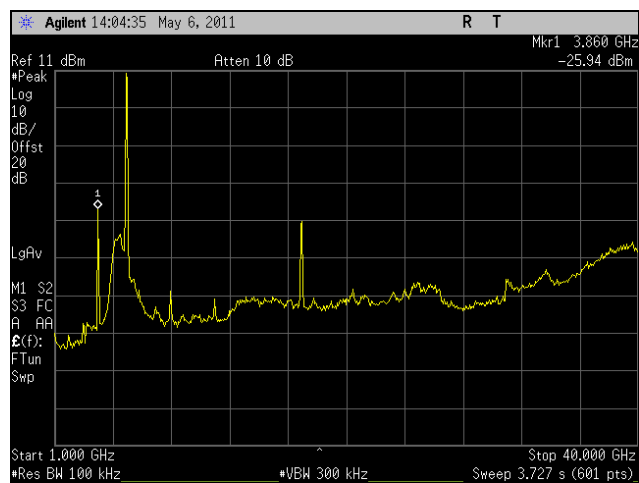

Plot 336. Conducted Spurious, High Channel, HT40, Port 2, 1 GHz - 40 GHz

Conducted Band Edge Test Results, 802.11a 20 MHz

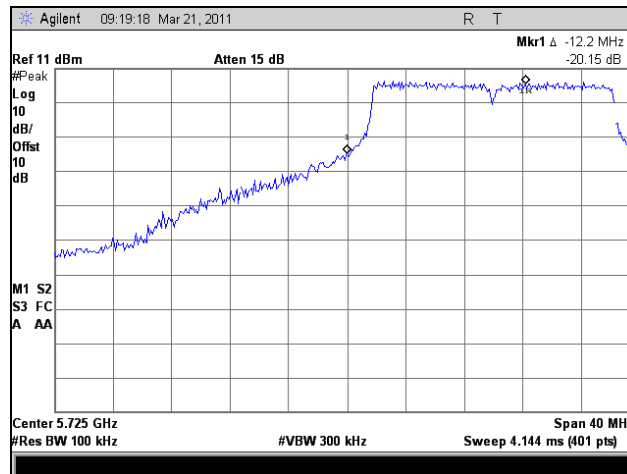

Plot 337. Conducted Band Edge, 802.11a 20 MHz, Low Channel

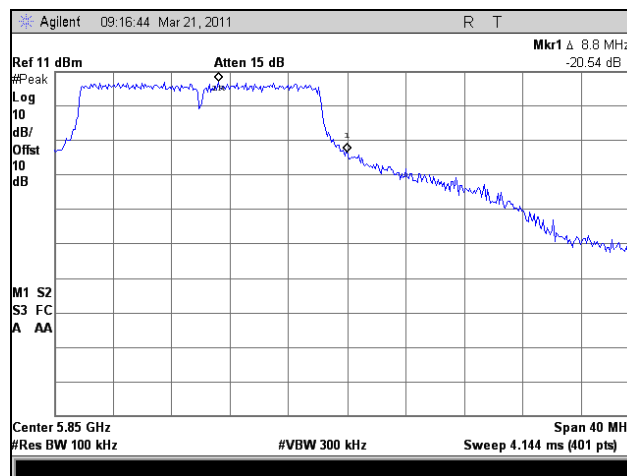

Plot 338. Conducted Band Edge, 802.11a 20 MHz, High Channel

Conducted Band Edge Test Results, 802.11a 40 MHz

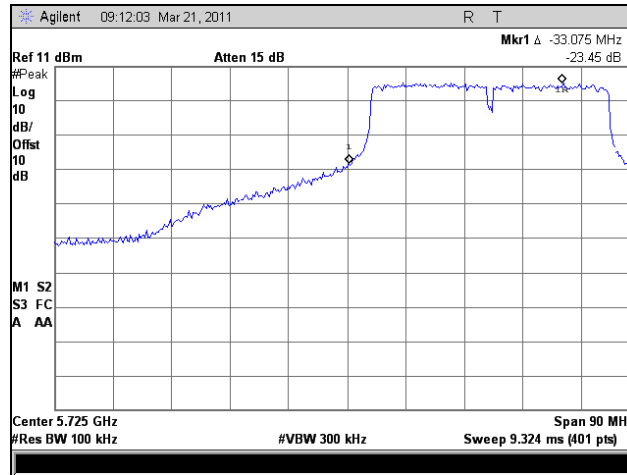

Plot 339. Conducted Band Edge, 802.11a 40 MHz, Low Channel

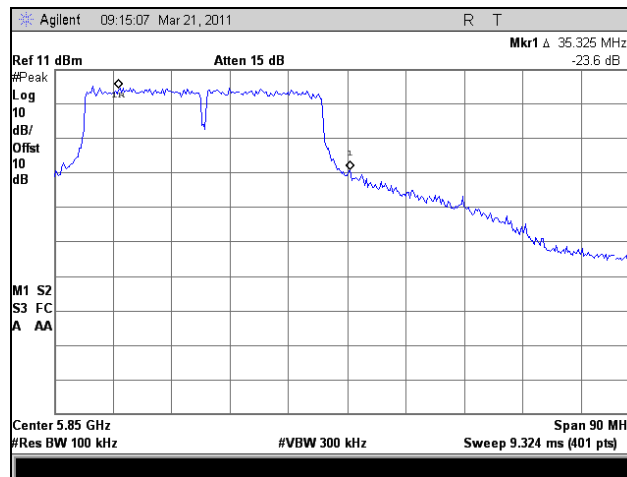

Plot 340. Conducted Band Edge, 802.11a 40 MHz, High Channel

Conducted Band Edge Test Results, HT5, Port 1

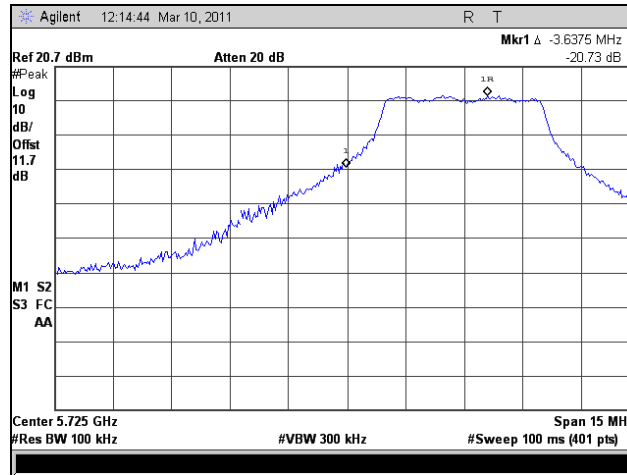

Plot 341. Conducted Band Edge, HT5, Low Channel, Port 1

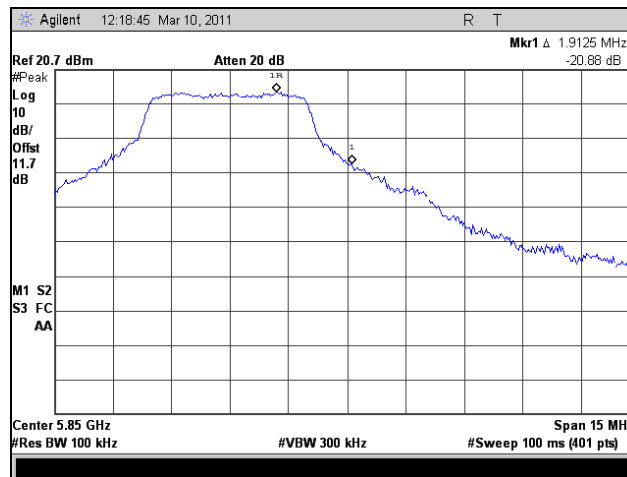

Plot 342. Conducted Band Edge, HT5, High Channel, Port 1

Conducted Band Edge Test Results, HT5, Port 2

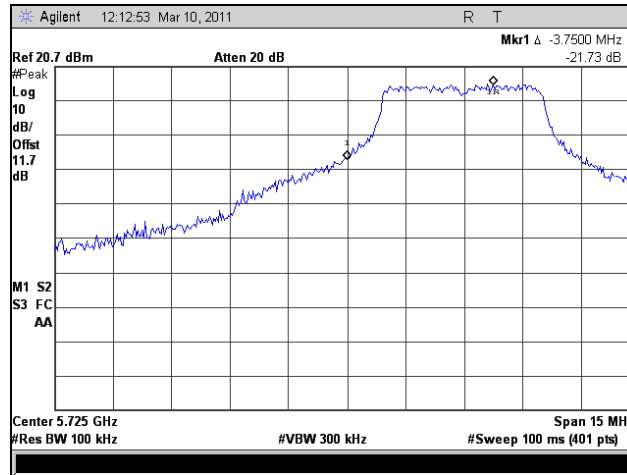

Plot 343. Conducted Band Edge, HT5, Low Channel, Port 2

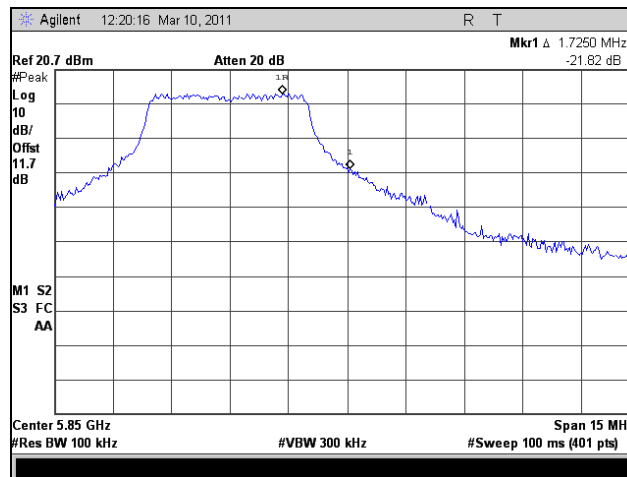

Plot 344. Conducted Band Edge, HT5, High Channel, Port 2

Conducted Band Edge Test Results, HT8, Port 1

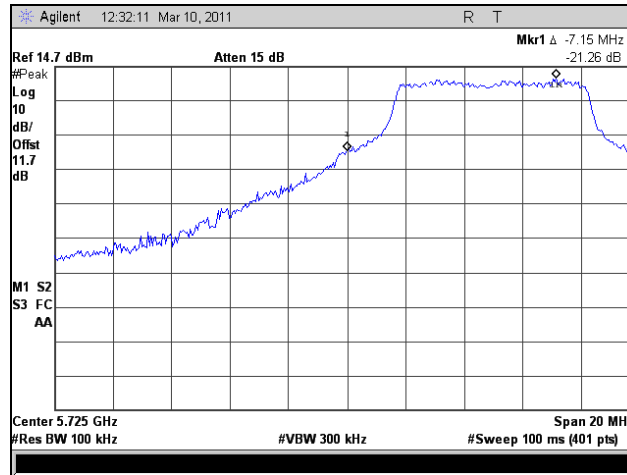

Plot 345. Conducted Band Edge, HT8, Low Channel, Port 1

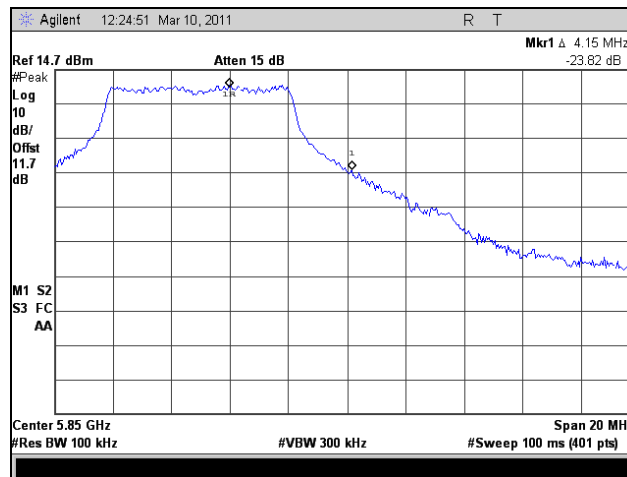

Plot 346. Conducted Band Edge, HT8, High Channel, Port 1

Conducted Band Edge Test Results, HT8, Port 2

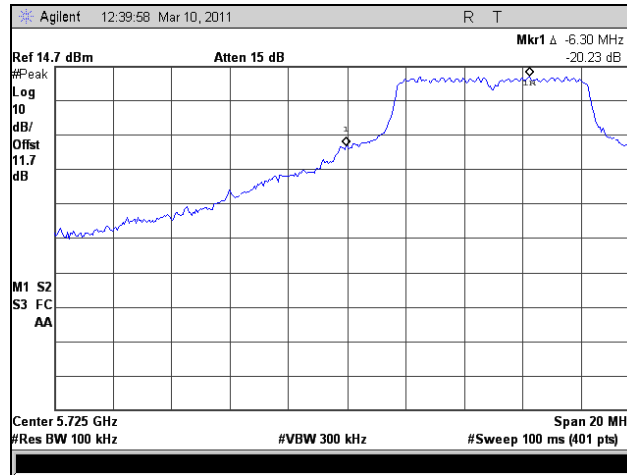

Plot 347. Conducted Band Edge, HT8, Low Channel, Port 2

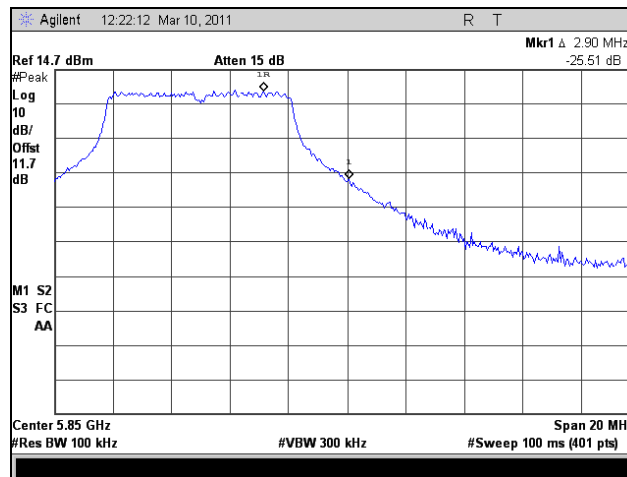

Plot 348. Conducted Band Edge, HT8, High Channel, Port 2

Conducted Band Edge Test Results, HT10, Port 1

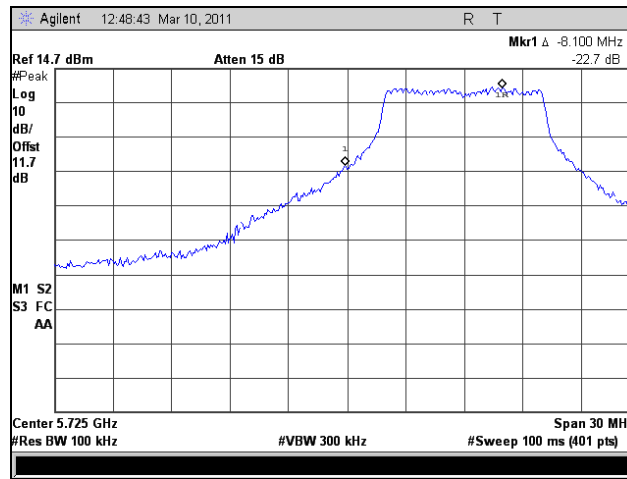

Plot 349. Conducted Band Edge, HT10, Low Channel, Port 1

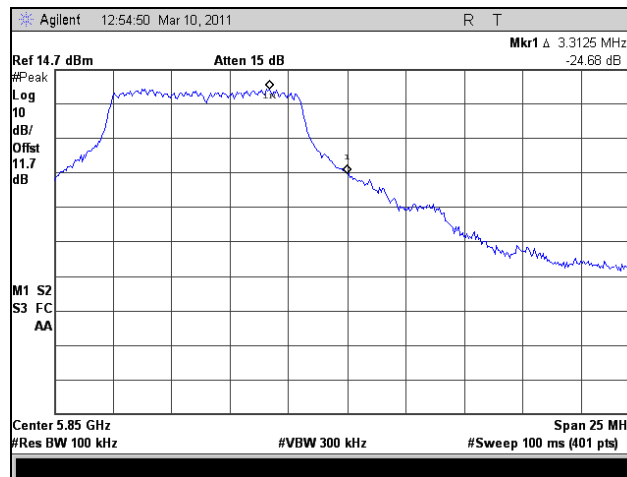

Plot 350. Conducted Band Edge, HT10, High Channel, Port 1

Conducted Band Edge Test Results, HT10, Port 2

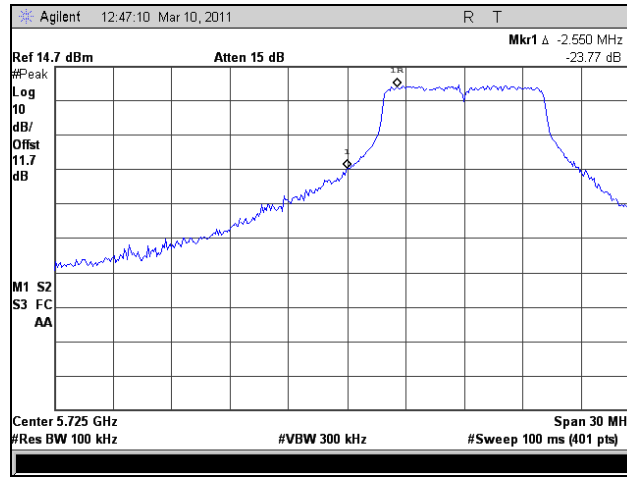

Plot 351. Conducted Band Edge, HT10, Low Channel, Port 2

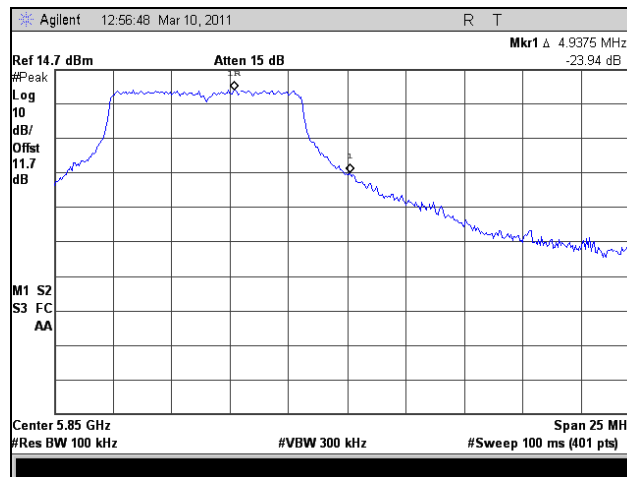

Plot 352. Conducted Band Edge, HT10, High Channel, Port 2

Conducted Band Edge Test Results, HT20, Port 1

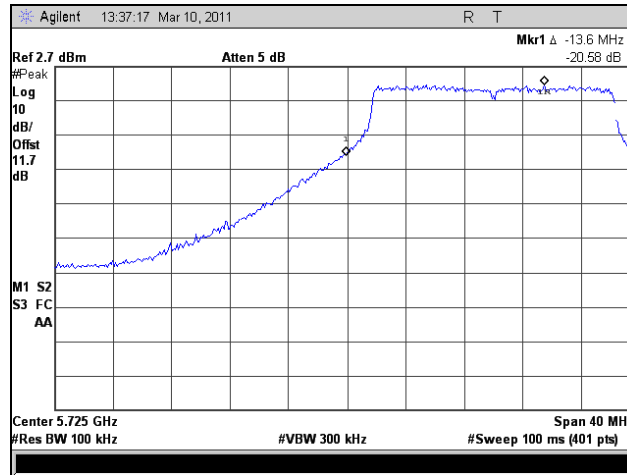

Plot 353. Conducted Band Edge, HT20, Low Channel, Port 1

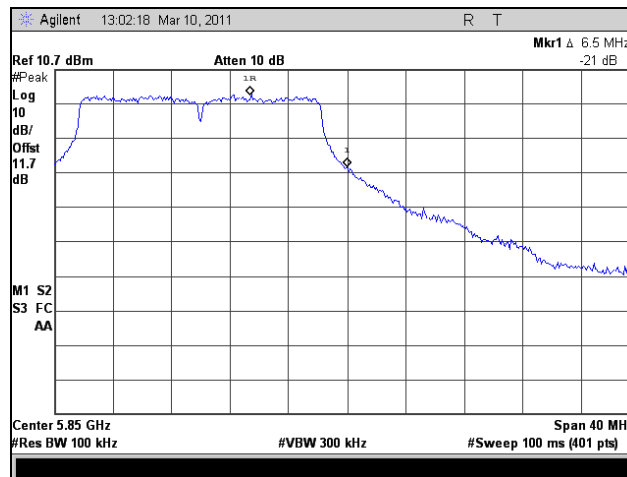

Plot 354. Conducted Band Edge, HT20, High Channel, Port 1

Conducted Band Edge Test Results, HT20, Port 2

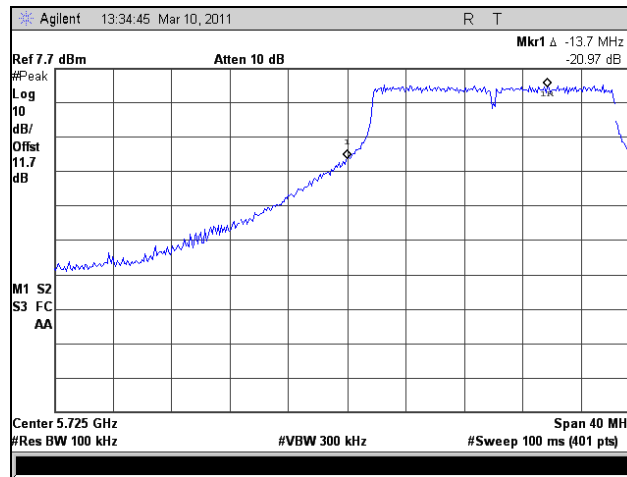

Plot 355. Conducted Band Edge, HT20, Low Channel, Port 2

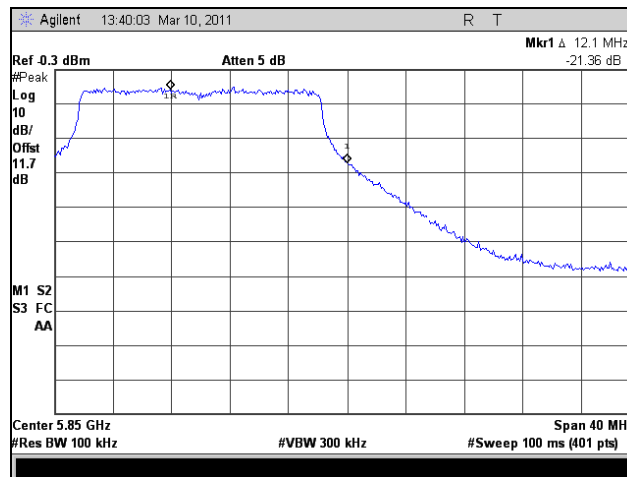

Plot 356. Conducted Band Edge, HT20, High Channel, Port 2

Conducted Band Edge Test Results, HT30, Port 1

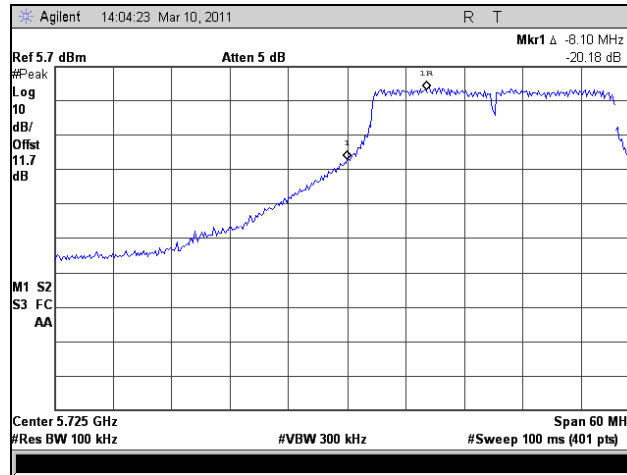

Plot 357. Conducted Band Edge, HT30, Low Channel, Port 1

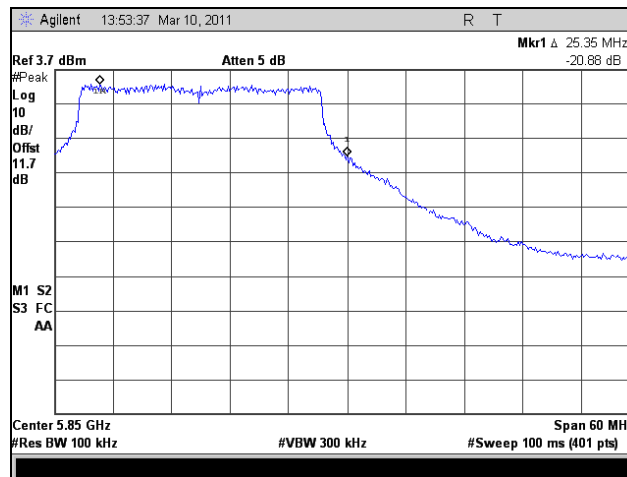

Plot 358. Conducted Band Edge, HT30, High Channel, Port 1

Conducted Band Edge Test Results, HT30, Port 2

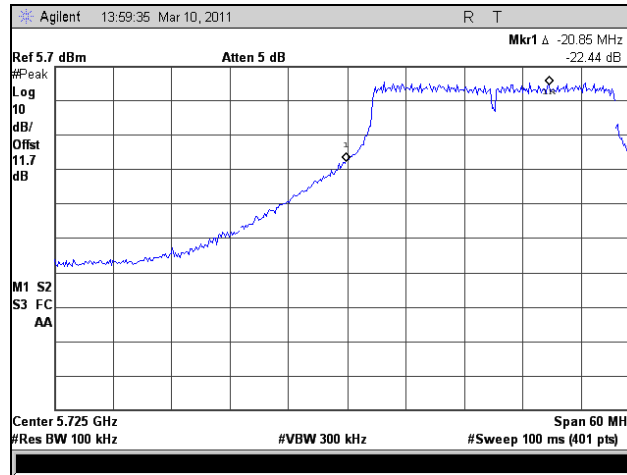

Plot 359. Conducted Band Edge, HT30, Low Channel, Port 2

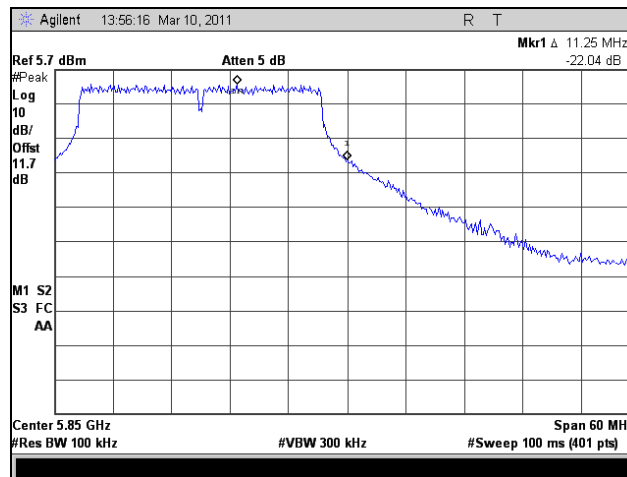

Plot 360. Conducted Band Edge, HT30, High Channel, Port 2

Conducted Band Edge Test Results, HT40, Port 1

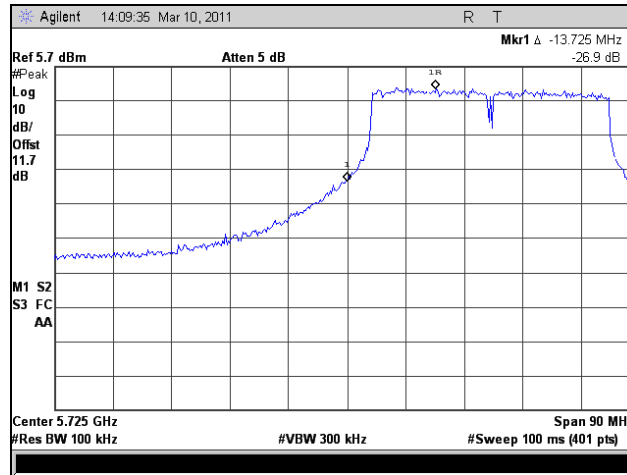

Plot 361. Conducted Band Edge, HT40, Low Channel, Port 1

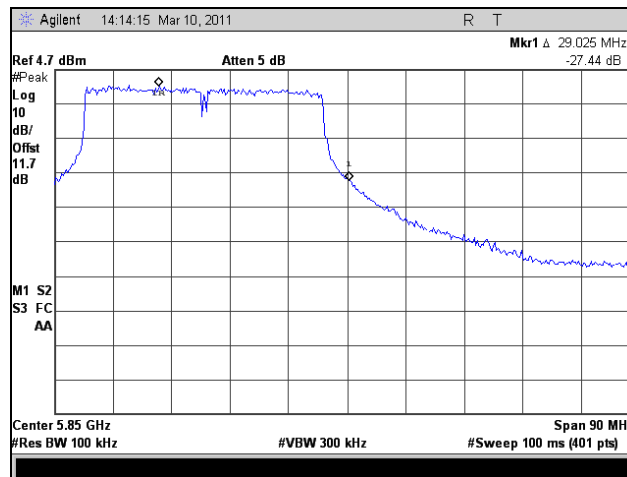

Plot 362. Conducted Band Edge, HT40, High Channel, Port 1

Conducted Band Edge Test Results, HT40, Port 2

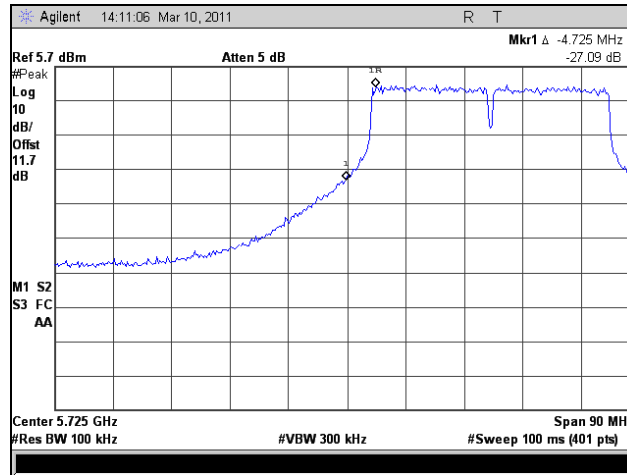

Plot 363. Conducted Band Edge, HT40, Low Channel, Port 2

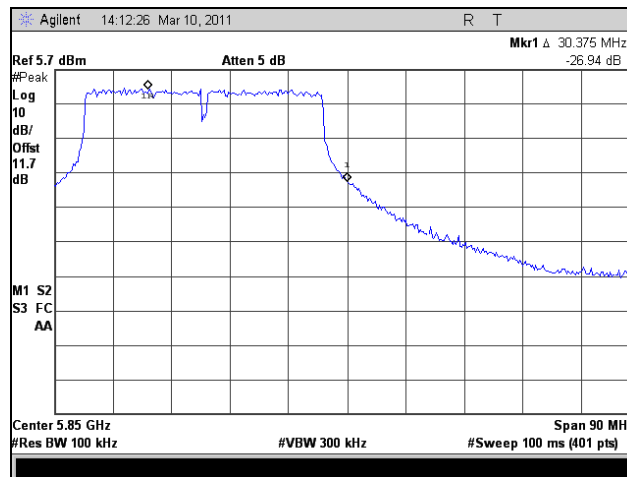

Plot 364. Conducted Band Edge, HT40, High Channel, Port 2

Electromagnetic Compatibility Criteria for Intentional Radiators

§ 15.247(e) Peak Power Spectral Density

Test Requirements: §15.247(e): For digitally modulated systems, the peak power spectral density conducted from the intentional radiator to the antenna shall not be greater than 8dBm in any 3 kHz band during any time interval of continuous transmission.

Test Procedure: The transmitter was connected directly to a Spectrum Analyzer through an attenuator. The power level was set to the maximum level. A RBW of 1 MHz and VBW of 3 MHz were used to determine the peak emissions within the band. The Spectrum analyzer was then set to a RBW of 3 kHz and VBW was set to 10 kHz. The SPAN of the analyzer was set to 1 MHz with a 333.3 second sweep. Measurements were carried out at the low, mid and high channels.

Test Results: The EUT was compliant with the peak power spectral density limits of § 15.247 (e).
The peak power spectral density was determined from plots on the following page(s).

Test Engineer: Lionel Gabrillo

Test Date: 03/10/11

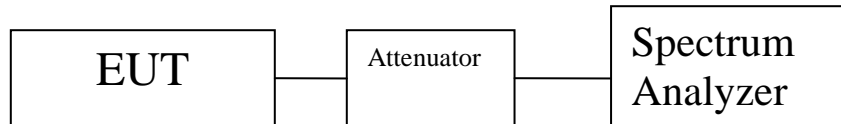

Figure 5. Block Diagram, Peak Power Spectral Density Test Setup

Peak Power Spectral Density Test Results

Peak Power Spectral Density					
Mode	Carrier Channel	Frequency (MHz)	Measured PPSD (dBm)	Limit (dBm)	Margin (dB)
802.11a 20 MHz	Low	5735	-5.557	8	-13.557
	Mid	5787	-4.449	8	-12.449
	High	5840	-4.518	8	-12.518
802.11a 40 MHz	Low	5747	-7.04	8	-15.04
	Mid	5787	-7.762	8	-15.762
	High	5828	-7.969	8	-15.969
HT5 Port 1	Low	5728	1.441	8	-6.559
	Mid	5787	-1.574	8	-9.574
	High	5847	0.699	8	-7.301
HT5 Port 2	Low	5728	-1.176	8	-9.176
	Mid	5787	-2.08	8	-10.08
	High	5847	-2.62	8	-10.62
HT8 Port 1	Low	5730	-2.222	8	-10.222
	Mid	5787	-4.235	8	-12.235
	High	5845	-1.624	8	-9.624
HT8 Port 2	Low	5730	-3.644	8	-11.644
	Mid	5787	-4.358	8	-12.358
	High	5845	-4.564	8	-12.564
HT10 Port 1	Low	5731	-2.362	8	-10.362
	Mid	5787	-5.348	8	-13.348
	High	5844	-7.165	8	-15.165
HT10 Port 2	Low	5731	-4.907	8	-12.907
	Mid	5787	-4.994	8	-12.994
	High	5844	-6.474	8	-14.474
HT20 Port 1	Low	5735	-6.254	8	-14.254
	Mid	5787	-6.844	8	-14.844
	High	5840	-9.455	8	-17.455
HT20 Port 2	Low	5735	-5.198	8	-13.198
	Mid	5787	-7.859	8	-15.859
	High	5840	-8.736	8	-16.736
HT30 Port 1	Low	5740	-8.752	8	-16.752
	Mid	5787	-10.34	8	-18.34
	High	5835	-12.23	8	-20.23
HT30 Port 2	Low	5740	-11.15	8	-19.15
	Mid	5787	-11.67	8	-19.67
	High	5835	-12.71	8	-20.71
HT40 Port 1	Low	5747	-9.84	8	-17.84
	Mid	5787	-12.16	8	-20.16
	High	5828	-13.88	8	-21.88
HT40 Port 2	Low	5747	-11.8	8	-19.8
	Mid	5787	-13.04	8	-21.04
	High	5828	-13.23	8	-21.23

Table 41. Peak Power Spectral Density, Test Results

HT5								
Channel	Port 1 (dBm)	Port 1 + 10log(# of Ports)	Limit (dBm)	Delta	Port 2 (dBm)	Port 2 + 10log(# of Ports)	Limit (dBm) Port2	Port2 Delta
Low	1.441	4.451	8.000	-3.549	-1.176	1.834	8.000	-6.166
Mid	-1.574	1.436	8.000	-6.564	-2.08	0.930	8.000	-7.070
High	0.699	3.709	8.000	-4.291	-2.62	0.390	8.000	-7.610
HT8								
Channel	Port 1 (dBm)	Port 1 + 10log(# of Ports)	Limit (dBm)	Delta	Port 2 (dBm)	Port 2 + 10log(# of Ports)	Limit (dBm) Port2	Port2 Delta
Low	-2.222	0.788	8.000	-7.212	-3.644	-0.634	8.000	-8.634
Mid	-4.235	-1.225	8.000	-9.225	-4.538	-1.528	8.000	-9.528
High	-1.627	1.383	8.000	-6.617	-4.564	-1.554	8.000	-9.554
HT10								
Channel	Port 1 (dBm)	Port 1 + 10log(# of Ports)	Limit (dBm)	Delta	Port 2 (dBm)	Port 2 + 10log(# of Ports)	Limit (dBm) Port2	Port2 Delta
Low	-2.632	0.378	8.000	-7.622	-4.907	-1.897	8.000	-9.897
Mid	-5.348	-2.338	8.000	-10.338	-4.994	-1.984	8.000	-9.984
High	-7.165	-4.155	8.000	-12.155	-6.474	-3.464	8.000	-11.464
HT20								
Channel	Port 1 (dBm)	Port 1 + 10log(# of Ports)	Limit (dBm)	Delta	Port 2 (dBm)	Port 2 + 10log(# of Ports)	Limit (dBm) Port2	Port2 Delta
Low	-6.254	-3.244	8.000	-11.244	-5.198	-2.188	8.000	-10.188
Mid	-6.844	-3.834	8.000	-11.834	-7.589	-4.579	8.000	-12.579
High	-9.455	-6.445	8.000	-14.445	-8.736	-5.726	8.000	-13.726
HT30								
Channel	Port 1 (dBm)	Port 1 + 10log(# of Ports)	Limit (dBm)	Delta	Port 2 (dBm)	Port 2 + 10log(# of Ports)	Limit (dBm) Port2	Port2 Delta
Low	-8.752	-5.742	8.000	-13.742	-11.150	-8.140	8.000	-16.140
Mid	-10.34	-7.330	8.000	-15.330	-11.67	-8.660	8.000	-16.660
High	-12.23	-9.220	8.000	-17.220	-12.71	-9.700	8.000	-17.700
HT40								
Channel	Port 1 (dBm)	Port 1 + 10log(# of Ports)	Limit (dBm)	Delta	Port 2 (dBm)	Port 2 + 10log(# of Ports)	Limit (dBm) Port2	Port2 Delta
Low	-9.84	-6.830	8.000	-14.830	-11.8	-8.790	8.000	-16.790
Mid	-12.16	-9.150	8.000	-17.150	-13.04	-10.030	8.000	-18.030
High	-13.88	-10.870	8.000	-18.870	-13.23	-10.220	8.000	-18.220

Table 42. Peak Power Spectral Density, Summed

Peak Power Spectral Density, 802.11a 20 MHz

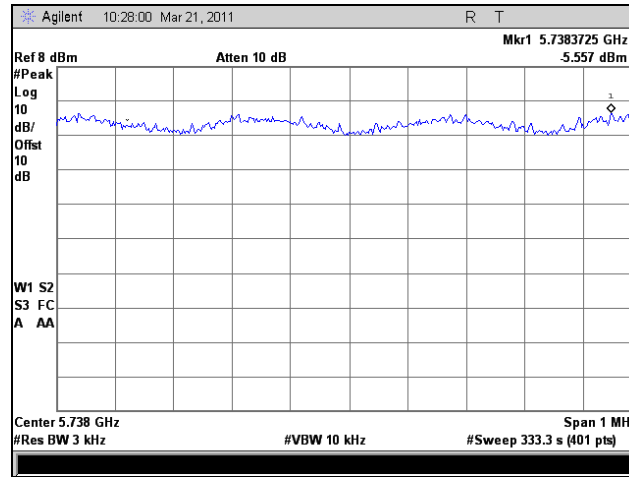

Plot 365. Peak Power Spectral Density, 802.11 20 MHz, Low Channel

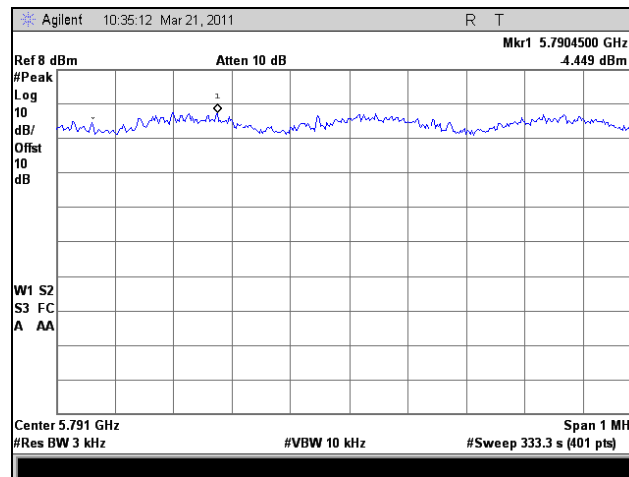

Plot 366. Peak Power Spectral Density, 802.11a 20 MHz, Mid Channel

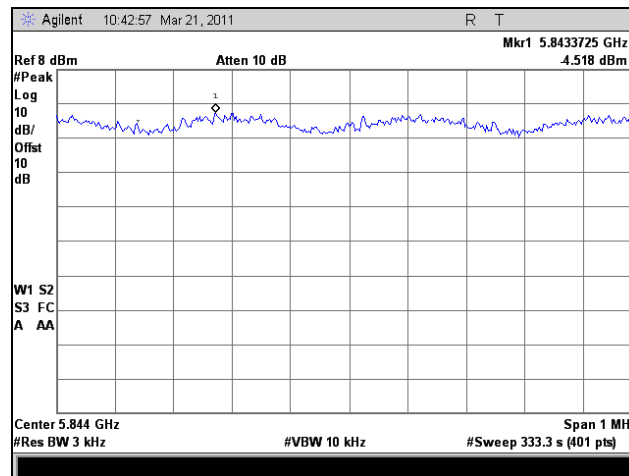

Plot 367. Peak Power Spectral Density, 802.11a 20 MHz, High Channel

Peak Power Spectral Density, 802.11a 40 MHz

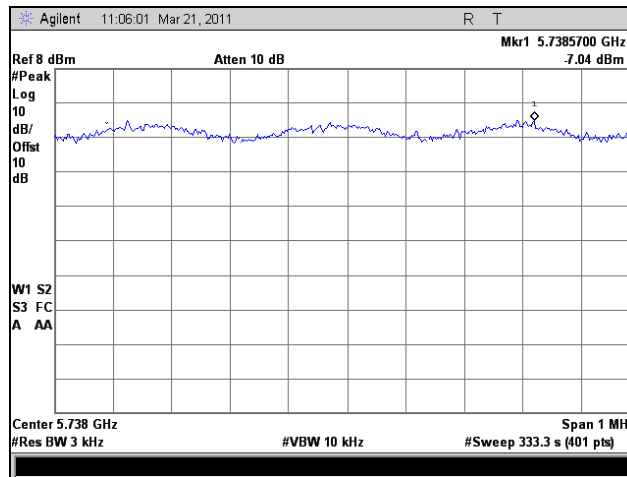

Plot 368. Peak Power Spectral Density, 802.11 40 MHz, Low Channel

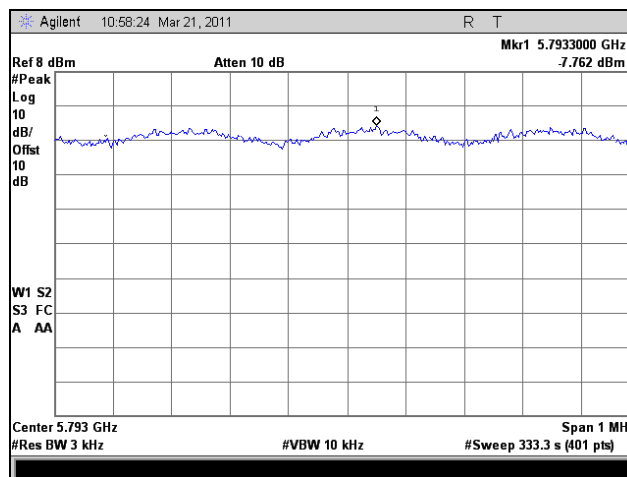

Plot 369. Peak Power Spectral Density, 802.11a 40 MHz, Mid Channel

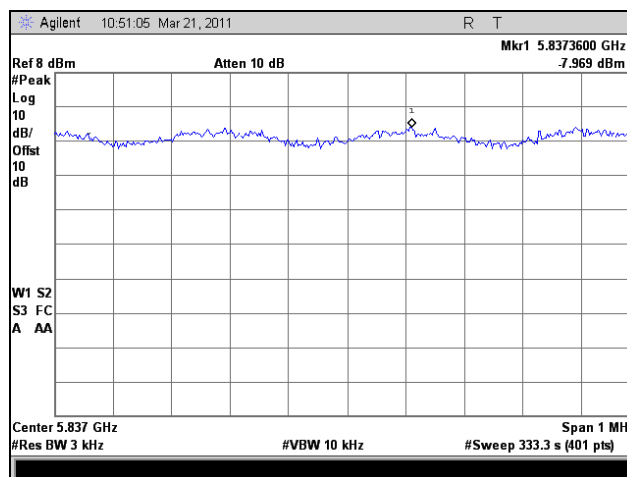

Plot 370. Peak Power Spectral Density, 802.11a 40 MHz, High Channel

Peak Power Spectral Density, HT5, Port 1

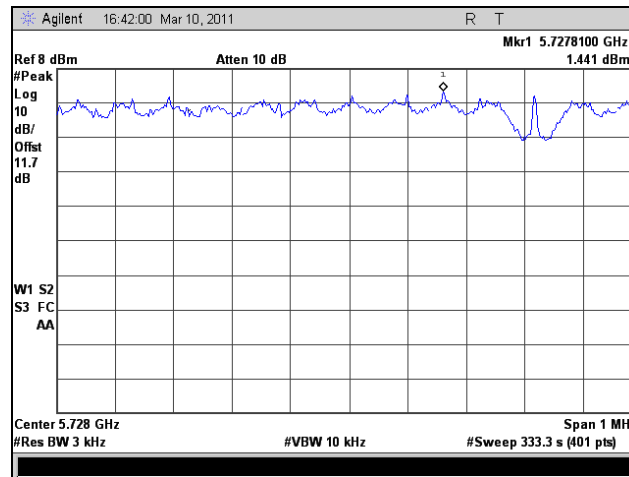

Plot 371. Peak Power Spectral Density, HT5, Port 1, Low Channel

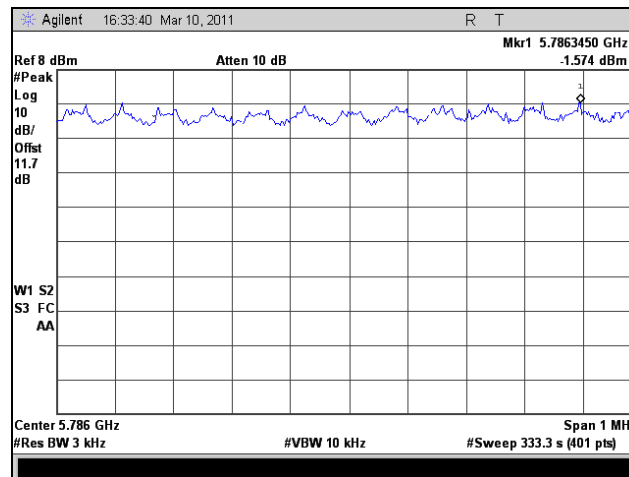

Plot 372. Peak Power Spectral Density, HT5, Port 1, Mid Channel

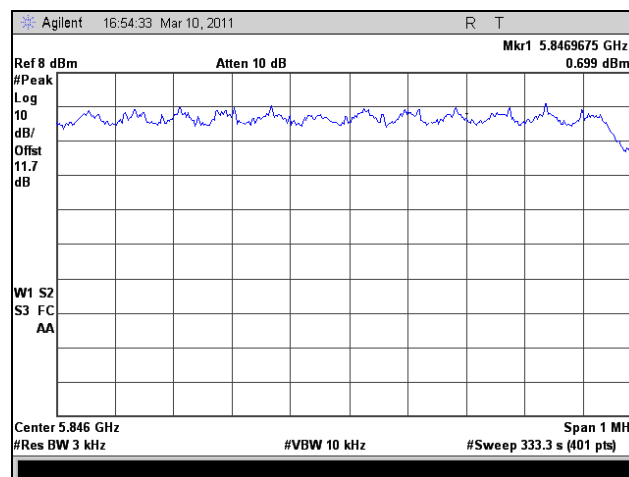

Plot 373. Peak Power Spectral Density, HT5, Port 1, High Channel

Peak Power Spectral Density, HT5, Port 2

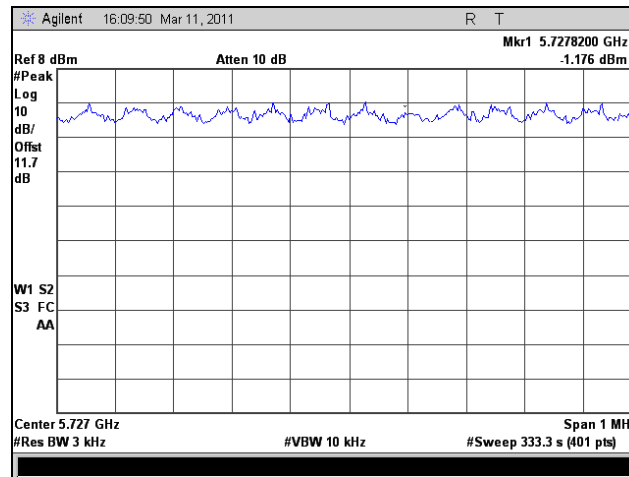

Plot 374. Peak Power Spectral Density, HT5 Port 2, Low Channel

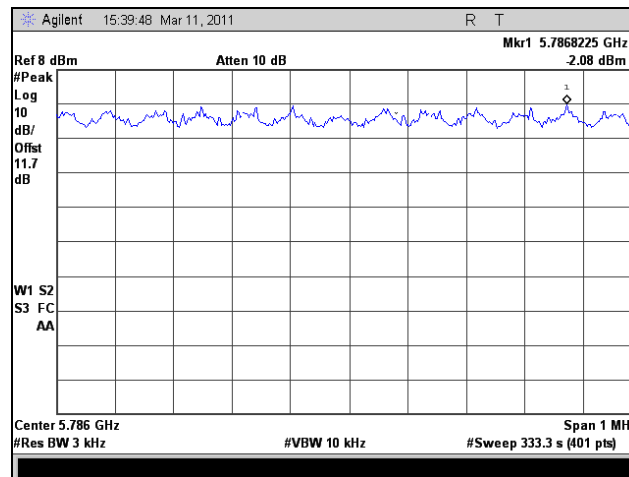

Plot 375. Peak Power Spectral Density, HT5, Port 2, Mid Channel

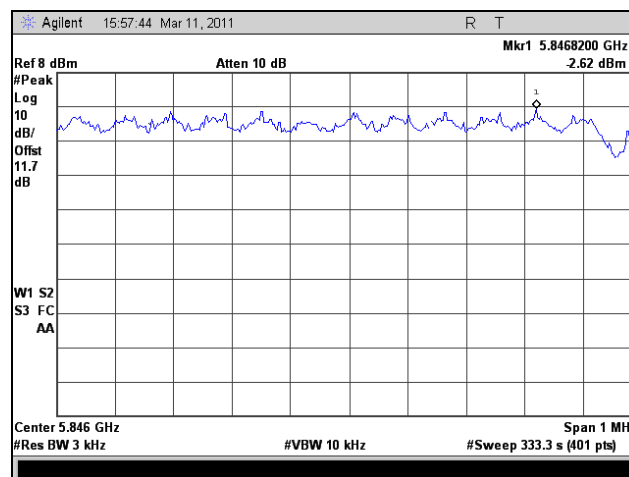

Plot 376. Peak Power Spectral Density, HT5, Port 2, High Channel

Peak Power Spectral Density, HT8, Port 1

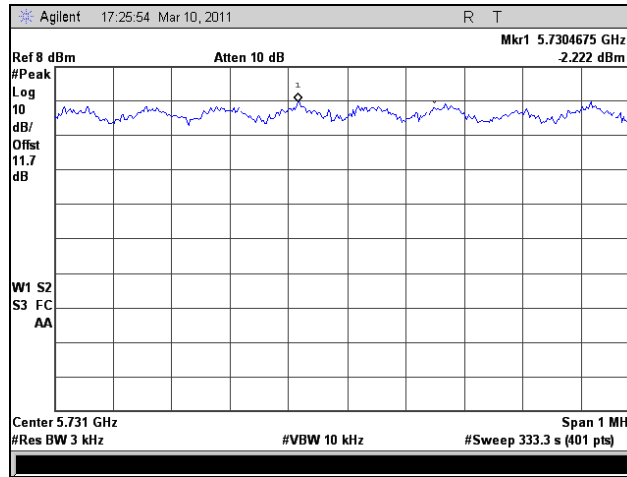

Plot 377. Peak Power Spectral Density, HT8, Port 1, Low Channel

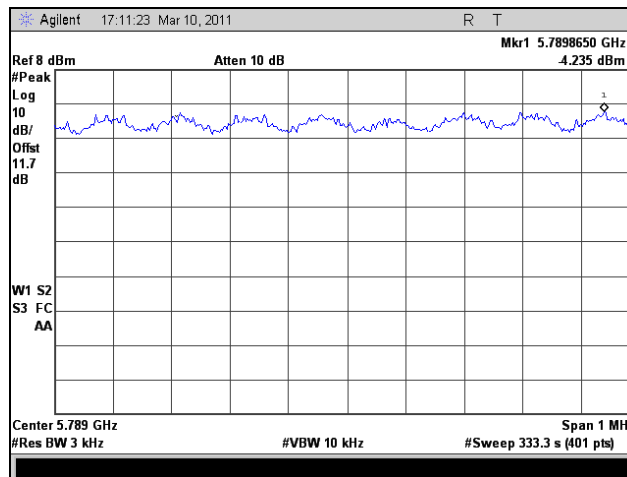

Plot 378. Peak Power Spectral Density, HT8, Port 1, Mid Channel

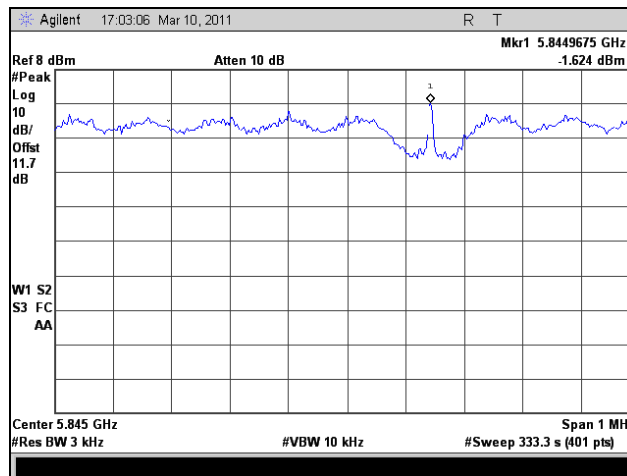

Plot 379. Peak Power Spectral Density, HT8, Port 1, High Channel

Peak Power Spectral Density, HT8, Port 2

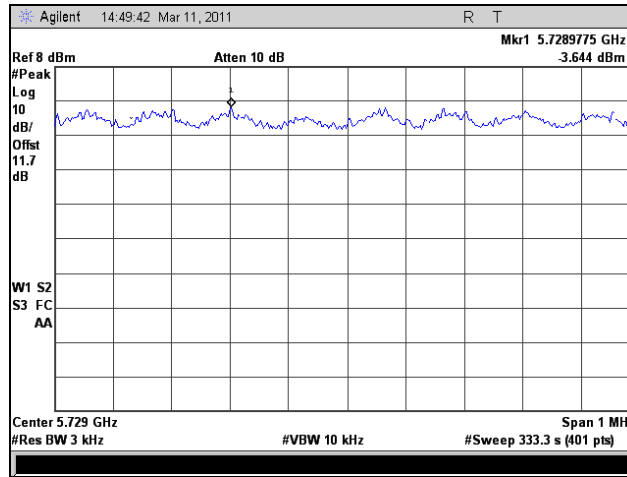

Plot 380. Peak Power Spectral Density, HT8, Port 2, Low Channel

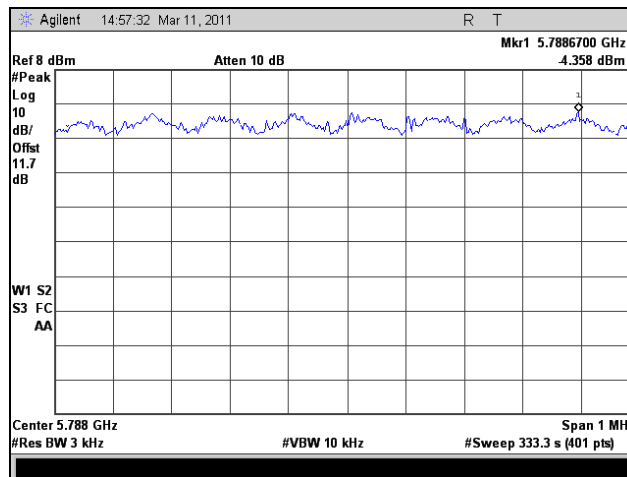

Plot 381. Peak Power Spectral Density, HT8, Port 2, Mid Channel

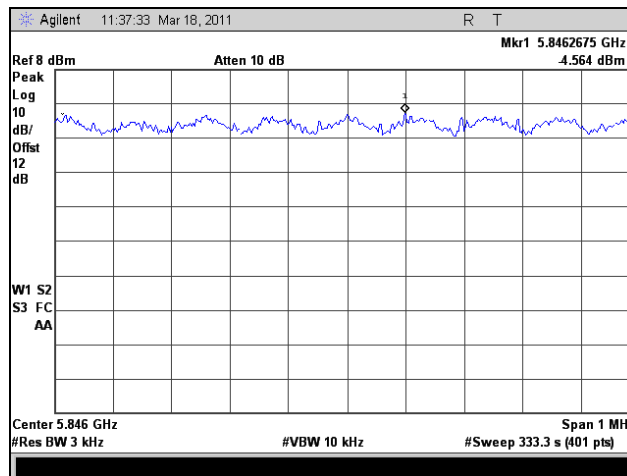

Plot 382. Peak Power Spectral Density, HT8, Port 2, High Channel

Peak Power Spectral Density, HT10, Port 1

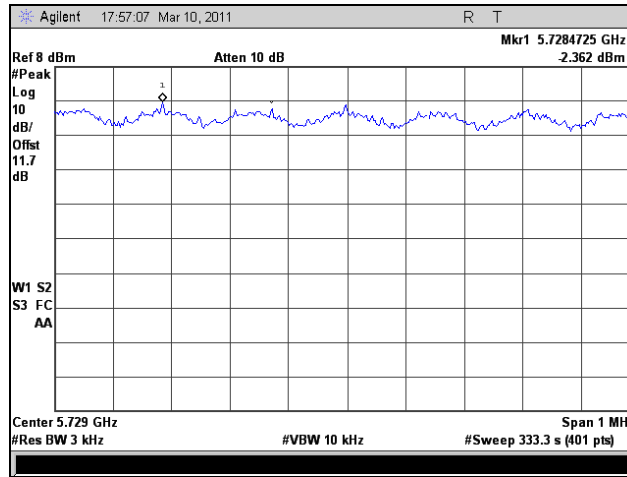

Plot 383. Peak Power Spectral Density, HT10, Port 1, Low Channel

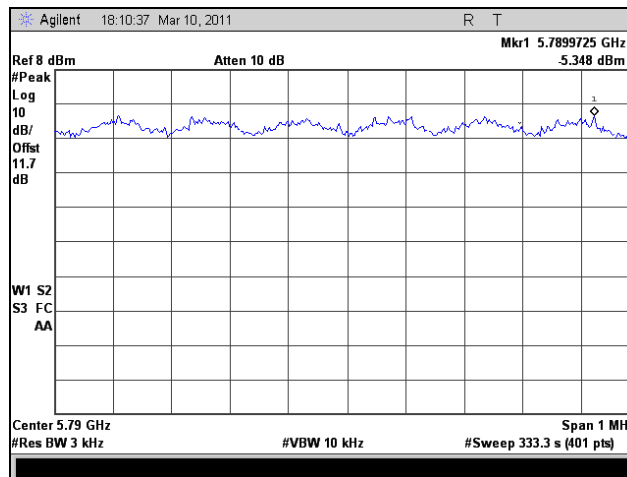

Plot 384. Peak Power Spectral Density, HT10, Port 1, Mid Channel

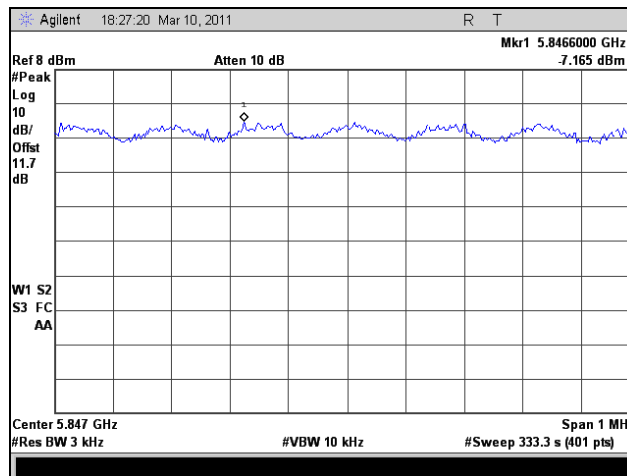

Plot 385. Peak Power Spectral Density, HT10, Port 1, High Channel

Peak Power Spectral Density, HT10, Port 2

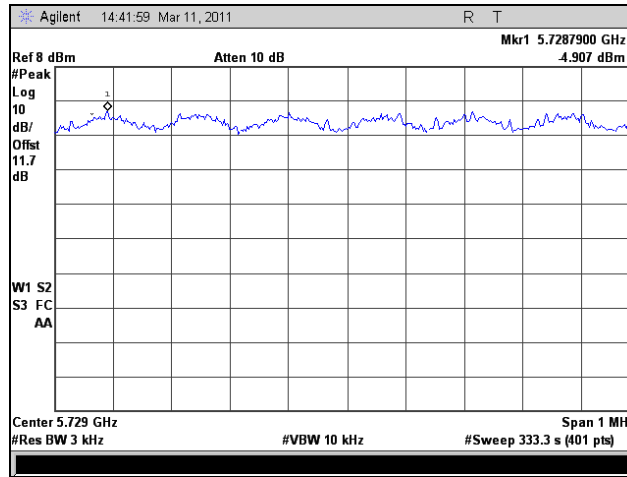

Plot 386. Peak Power Spectral Density, HT10, Port 2, Low Channel

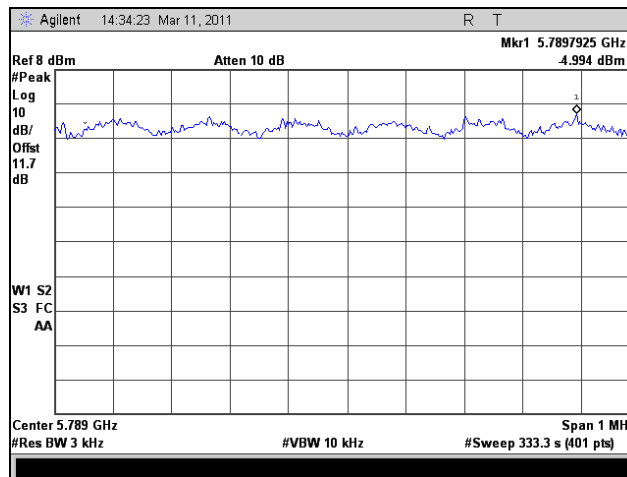

Plot 387. Peak Power Spectral Density, HT10, Port 2, Mid Channel

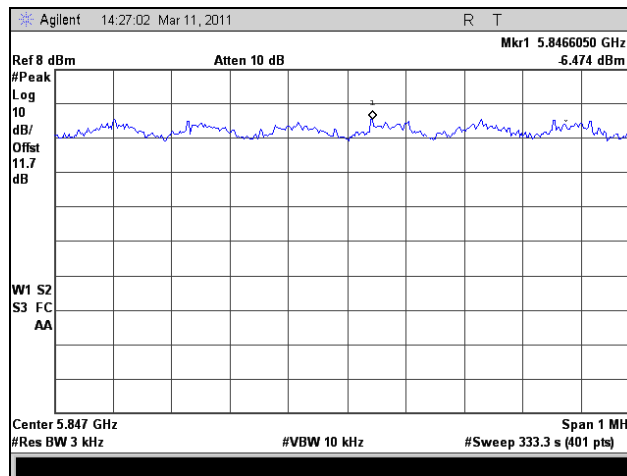

Plot 388. Peak Power Spectral Density, HT10, Port 2, High Channel

Peak Power Spectral Density, HT20, Port 1

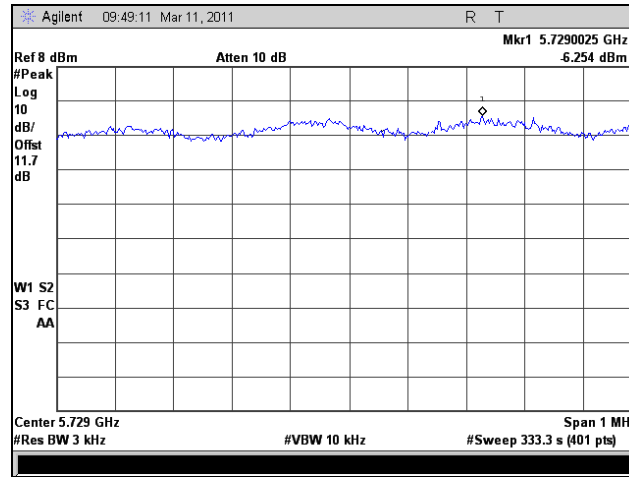

Plot 389. Peak Power Spectral Density, HT20, Port 1, Low Channel

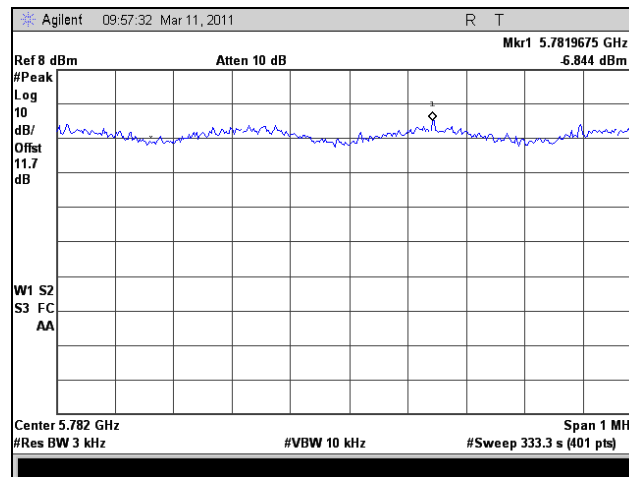

Plot 390. Peak Power Spectral Density, HT20, Port 1, Mid Channel

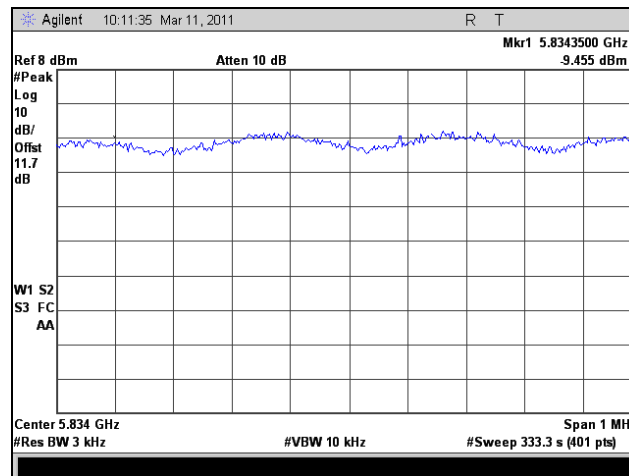

Plot 391. Peak Power Spectral Density, HT20, Port 1, High Channel

Peak Power Spectral Density, HT20, Port 2

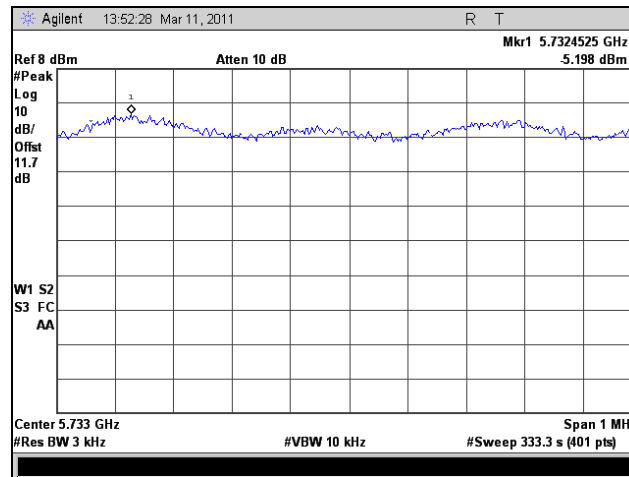

Plot 392. Peak Power Spectral Density, HT20, Port 2, Low Channel

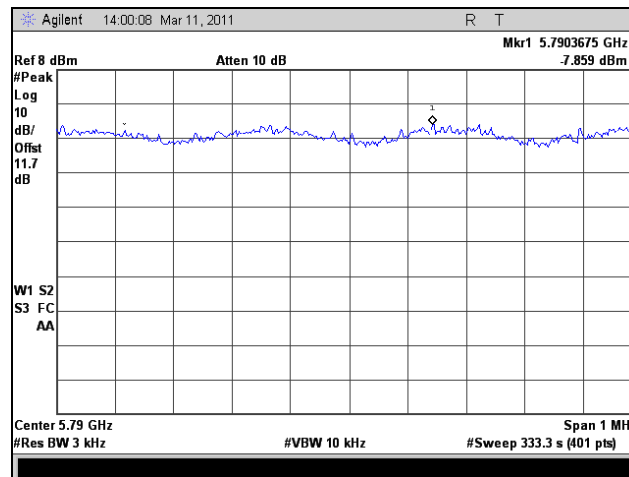

Plot 393. Peak Power Spectral Density, HT20, Port 2, Mid Channel

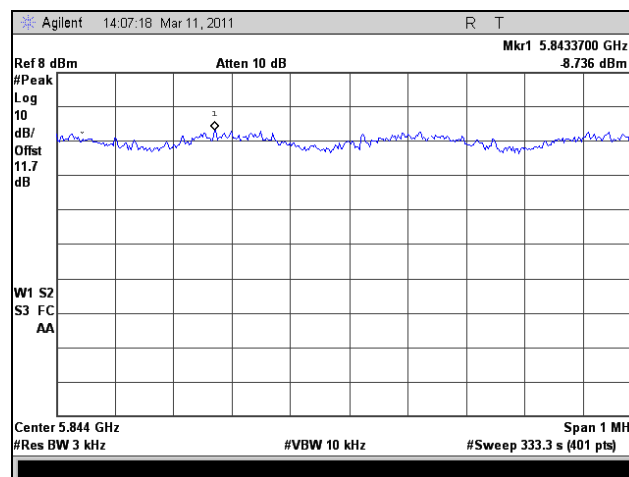

Plot 394. Peak Power Spectral Density, HT20, Port 2, High Channel

Peak Power Spectral Density, HT30, Port 1

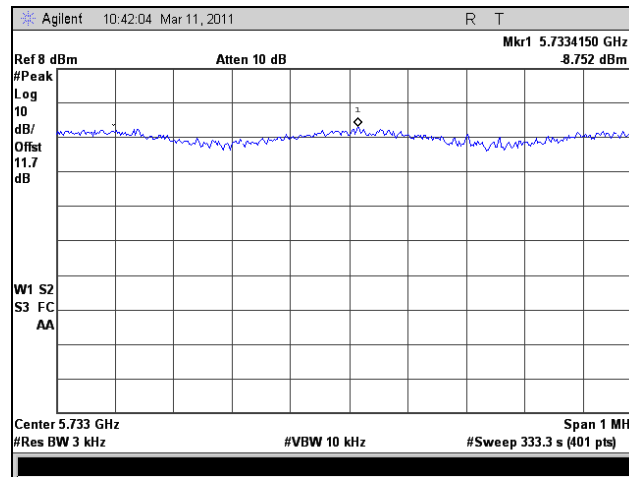

Plot 395. Peak Power Spectral Density, HT30, Port 1, Low Channel

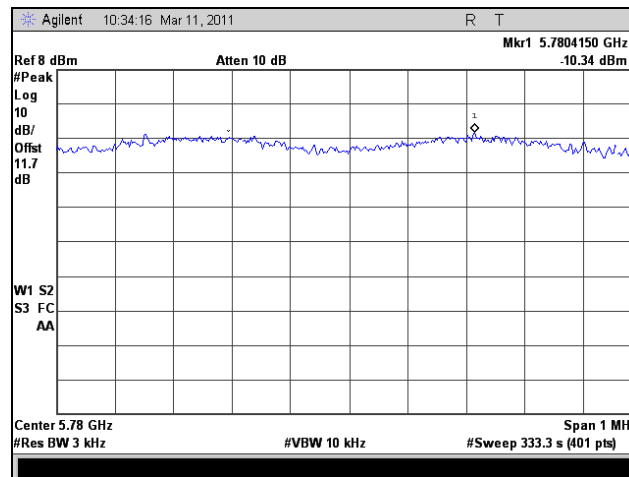

Plot 396. Peak Power Spectral Density, HT30, Port 1, Mid Channel

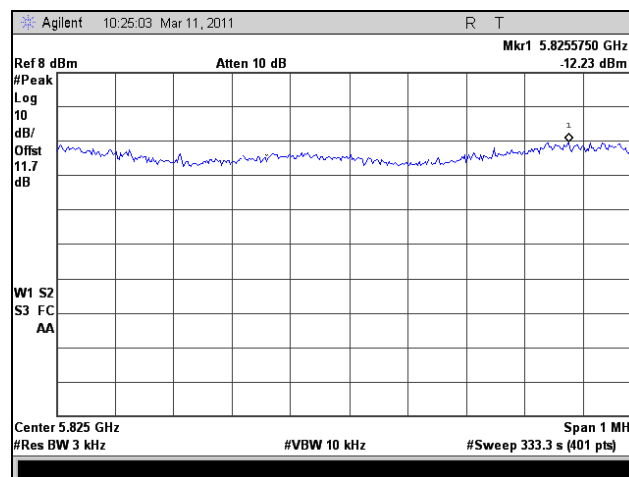

Plot 397. Peak Power Spectral Density, HT30, Port 1, High Channel

Peak Power Spectral Density, HT30, Port 2

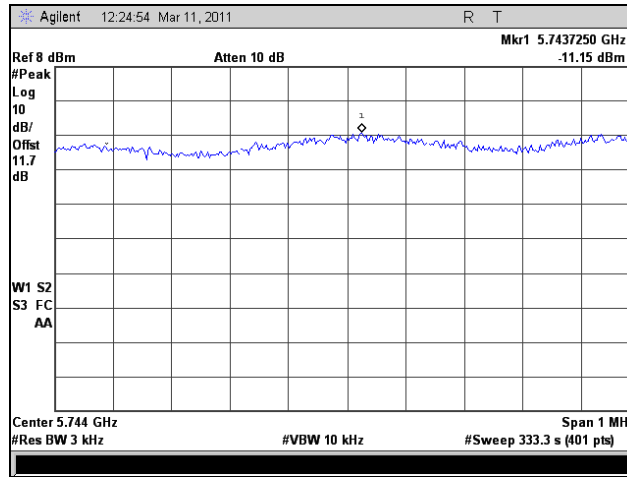

Plot 398. Peak Power Spectral Density, HT30 Port 2, Low Channel

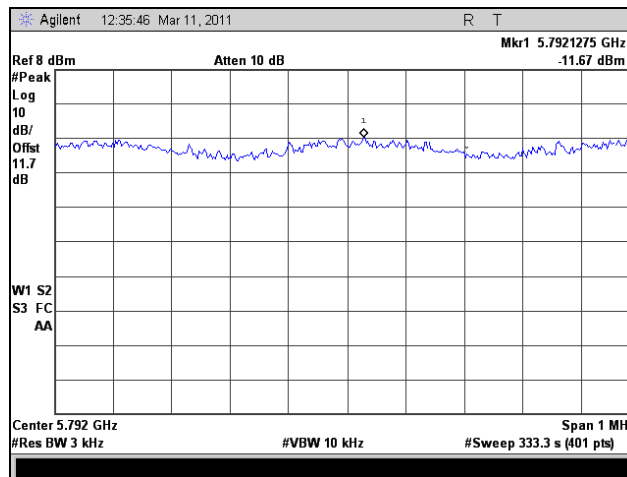

Plot 399. Peak Power Spectral Density, HT30, Port 2, Mid Channel

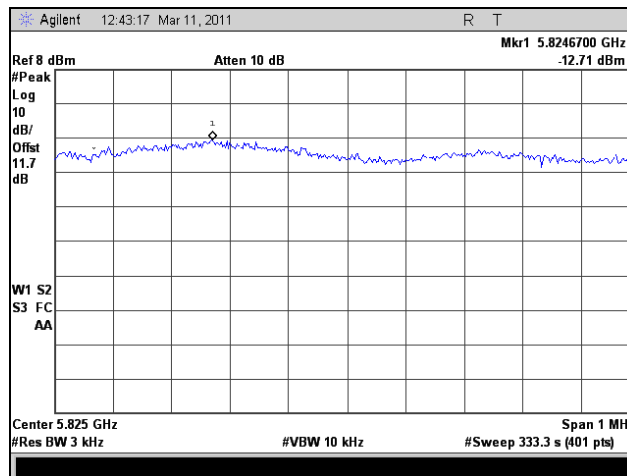

Plot 400. Peak Power Spectral Density, HT30, Port 2, High Channel

Peak Power Spectral Density, HT40, Port 1

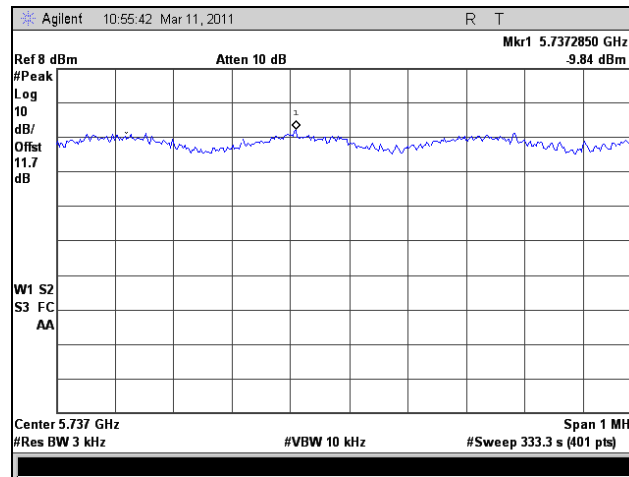

Plot 401. Peak Power Spectral Density, HT40, Port 1, Low Channel

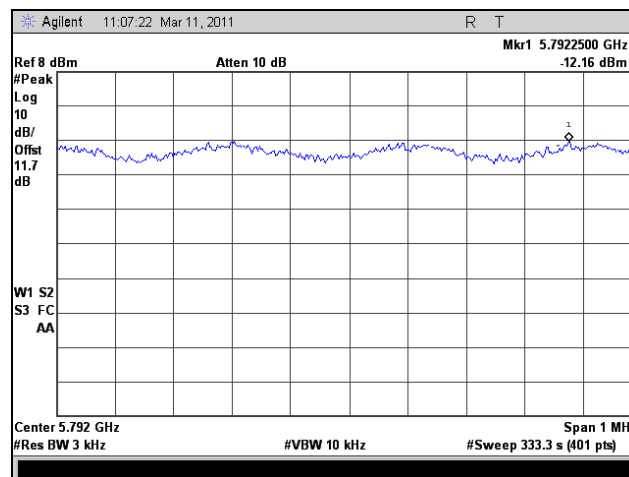

Plot 402. Peak Power Spectral Density, HT40, Port 1, Mid Channel

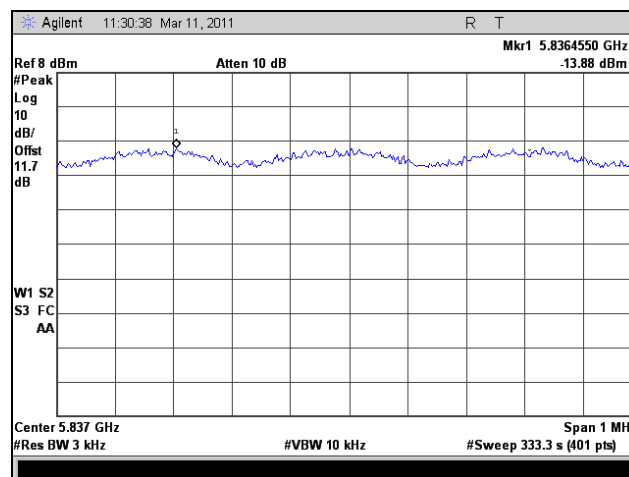

Plot 403. Peak Power Spectral Density, HT40, Port 1, High Channel

Peak Power Spectral Density, HT40, Port 2

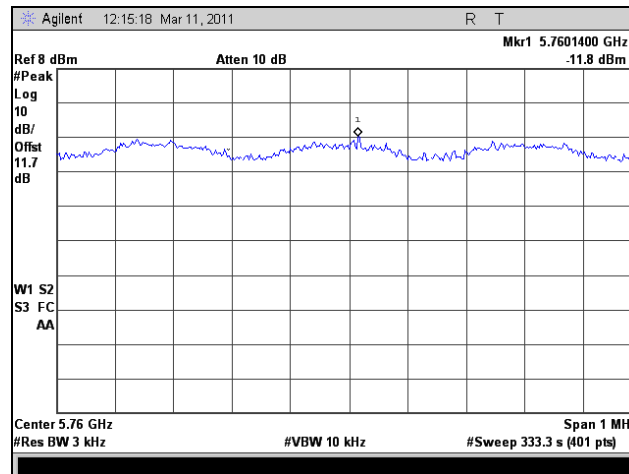

Plot 404. Peak Power Spectral Density, HT40 Port 2, Low Channel

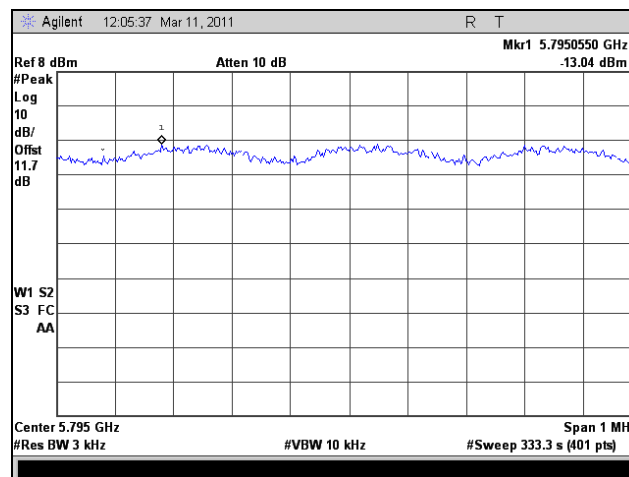

Plot 405. Peak Power Spectral Density, HT40, Port 2, Mid Channel

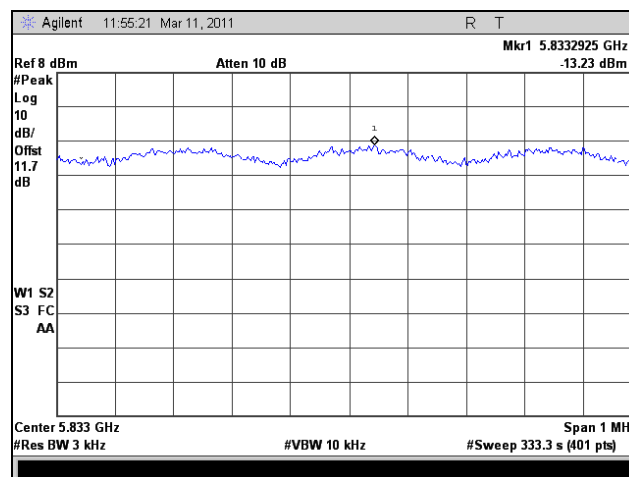

Plot 406. Peak Power Spectral Density, HT40, Port 2, High Channel

Electromagnetic Compatibility Criteria for Intentional Radiators

§ 15.247(i) Maximum Permissible Exposure

RF Exposure Requirements: §1.1307(b)(1) and §1.1307(b)(2): Systems operating under the provisions of this section shall be operated in a manner that ensures that the public is not exposed to radio frequency energy levels in excess of the Commission's guidelines.

RF Radiation Exposure Limit: §1.1310: As specified in this section, the Maximum Permissible Exposure (MPE) Limit shall be used to evaluate the environmental impact of human exposure to radiofrequency (RF) radiation as specified in Sec. 1.1307(b), except in the case of portable devices which shall be evaluated according to the provisions of Sec. 2.1093 of this chapter.

MPE Limit Calculation: EUT's operating frequencies @ 5725 - 5850 MHz; highest conducted power = 29.851dBm (peak) therefore, **Limit for Uncontrolled exposure: 1 mW/cm² or 10 W/m²**

EUT maximum antenna gain = 26.5 dBi.

Equation from page 18 of OET 65, Edition 97-01

$$S = PG / 4\pi R^2 \quad \text{or} \quad R = \sqrt{PG / 4\pi S}$$

where, S = Power Density (1 mW/cm²)

P = Power Input to antenna (418.79 mW)

G = Antenna Gain (446.68 numeric)

R = Minimum Distance between User and Antenna (20 cm)

$$S = (418.79 * 446.68) / (4 * 3.14 * 20^2) = 187068.20 / 5024 = 37.23 \text{ mW/cm}^2$$

Since $S > 1 \text{ mW/cm}^2$, the minimum distance should be

$$R = (418.79 * 446.68 / 4 * 3.14 * 1.0)^{1/2} = (187068.20 / 12.56)^{1/2} = 122.04 \text{ cm}$$

Electromagnetic Compatibility Criteria for Intentional Radiators

RSS-GEN Receiver Spurious Emissions Requirements

Test Requirements: The following receiver spurious emission limits shall be complied with:

- (a) If a radiated measurement is made, all spurious emissions shall comply with the limits of Table 43.

Spurious Frequency (MHz)	Field Strength (microvolt/m at 3 metres)
30 – 88	100
88 – 216	150
216 – 960	200
Above 960	500

Table 43. Spurious Emission Limits for Receivers

- (b) If a conducted measurement is made, no spurious output signals appearing at the antenna terminals shall exceed 2 nanowatts per any 4 kHz spurious frequency in the band 30-1000 MHz, or 5 nanowatts above 1 GHz.

Test Procedures: The EUT was programmed for receive mode only. Conducted measurements were taken at the antenna port of the EUT. 100 kHz resolution bandwidth was used from 30 MHz - 1 GHz and 1 MHz resolution was used for measurements done above 1 GHz. All plots are corrected for cable loss.

Test Results: Equipment is Compliant with the Receiver Spurious Emissions Requirements of RSS-GEN.

Test Engineer(s): Lionel Gabrillo

Test Date(s): 5/20/11

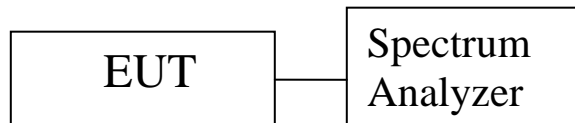
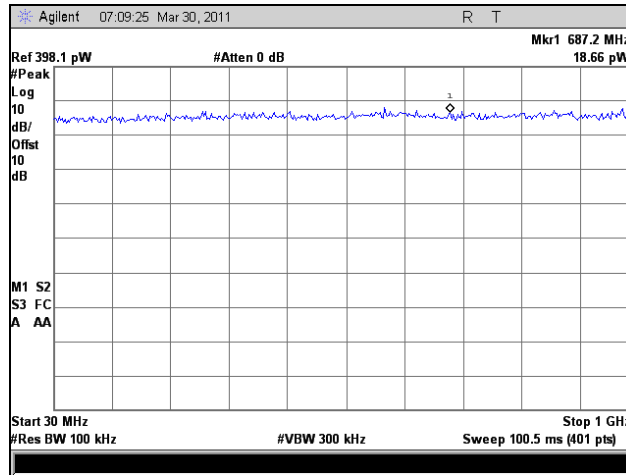
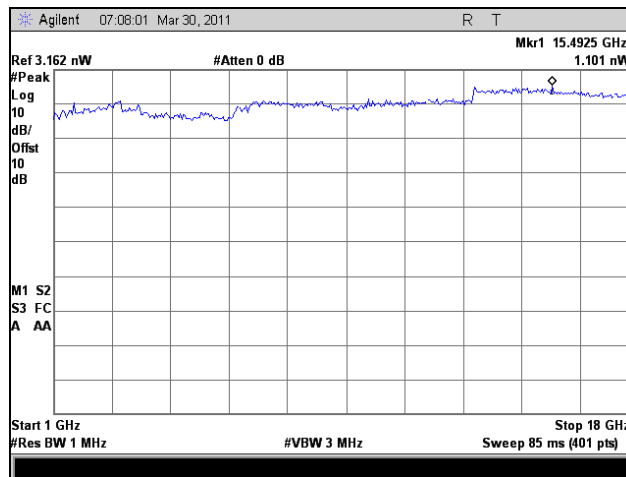

Figure 6. Block Diagram, Conducted Receiver Spurious Emissions Test Setup

Conducted Receiver Spurious Emissions



Plot 407. Receiver Spurious Emission, 30 MHz – 1 GHz, Port 1



Plot 408. Receiver Spurious Emission, 1 GHz – 18 GHz, Port 1

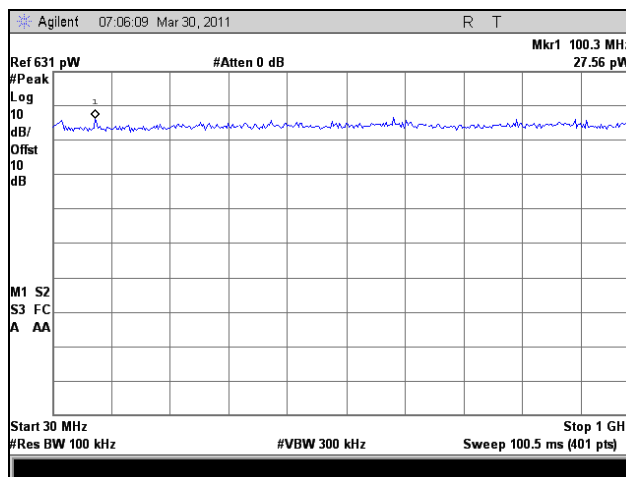

Plot 409. Receiver Spurious Emission, 30 MHz – 1 GHz, Port 2

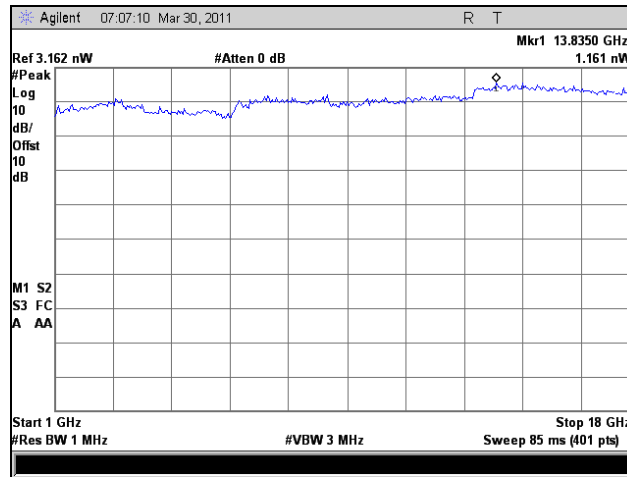

Plot 410. Receiver Spurious Emission, 1 GHz – 18 GHz, Port 2

IV. Test Equipment

Test Equipment

Calibrated test equipment utilized during testing was maintained in a current state of calibration per the requirements of ANSI/NCSL Z540-1-1994 and ANSI/ISO/IEC 17025:2000.

MET Asset #	Equipment	Manufacturer	Model	Last Cal Date	Cal Due Date
1S2583	SPECTRUM ANALYZER	AGILENT	E4447A	1/26/2010	2/26/2011
1S2678	LISN, DUAL-LINE V-NETWORK	TESEQ	NNB 51	12/1/2010	12/1/2011
1S2399	TURNTABLE CONTROLLER	SUNOL SCIENCE	SC99V	NO CALIBRATION REQUIRED	
1S2481	10M CHAMBER	ETS-LINDGREN	DKE 8X8 DBL	11/6/2010	11/6/2011
1S2482	5 METER CHAMBER	PANASHIELD	641431	11/13/2010	11/13/2011
1S2485	BILOG ANTENNA	TESEQ	CBL6112D	5/7/201	5/7/2011
1S2499	MULTI DEVICE CONTROLLER	ETS	2090	NO CALIBRATION REQUIRED	
1S2421	EMI TEST RECEIVER	ROHDE & SCHWARZ	ESIB7	7/6/2010	7/6/2011
1S2460	SPECTRUM ANALYZER	AGILENT	E4407B	7/13/2010	7/13/2011
1S2198	HORN ANTENNA	EMCO	3115	9/22/2010	9/22/2011
N/A	HIGH PASS FILTER	MICRO-TRONICS	HPM13147	SEE NOTE	
1S2521	THERMO-HYGROMETER	FISHER SCIENTIFIC	11-661-7D	12/2/2009	12/2/2011
1S2523	PREAMP (1-26.5GHZ)	AGILENT	8449B	SEE NOTE	
1S2128	HARMONIC MIXER	HEWLETT PACKARD	11970A	12/9/2010	12/9/2012
1S2129	HARMONIC MIXER	HEWLETT PACKARD	11970K	12/9/2010	12/9/2012

Table 44. Test Equipment List

Note: Functionally tested equipment is verified using calibrated instrumentation at the time of testing.

V. Certification & User's Manual Information

Certification & User's Manual Information

A. Certification Information

The following is extracted from Title 47 of the Code of Federal Regulations, Part 2, Subpart I — Marketing of Radio frequency devices:

§ 2.801 Radio-frequency device defined.

As used in this part, a radio-frequency device is any device which in its operation is capable of Emitting radio-frequency energy by radiation, conduction, or other means. Radio- frequency devices include, but are not limited to:

- (a) The various types of radio communication transmitting devices described throughout this chapter.
- (b) *The incidental, unintentional and intentional radiators defined in Part 15 of this chapter.*
- (c) The industrial, scientific, and medical equipment described in Part 18 of this chapter.
- (d) Any part or component thereof which in use emits radio-frequency energy by radiation, conduction, or other means.

§ 2.803 Marketing of radio frequency devices prior to equipment authorization.

- (a) Except as provided elsewhere in this chapter, no person shall sell or lease, or offer for sale or lease (including advertising for sale or lease), or import, ship or distribute for the purpose of selling or leasing or offering for sale or lease, any radio frequency device unless:
 - (1) In the case of a device subject to certification, such device has been authorized by the Commission in accordance with the rules in this chapter and is properly identified and labeled as required by §2.925 and other relevant sections in this chapter; or
 - (2) In the case of a device that is not required to have a grant of equipment authorization issued by the Commission, but which must comply with the specified technical standards prior to use, such device also complies with all applicable administrative (including verification of the equipment or authorization under a Declaration of Conformity, where required), technical, labeling and identification requirements specified in this chapter.
- (d) Notwithstanding the provisions of paragraph (a) of this section, the offer for sale solely to business, commercial, industrial, scientific or medical users (but not an offer for sale to other parties or to end users located in a residential environment) of a radio frequency device that is in the conceptual, developmental, design or pre-production stage is permitted prior to equipment authorization or, for devices not subject to the equipment authorization requirements, prior to a determination of compliance with the applicable technical requirements *provided* that the prospective buyer is advised in writing at the time of the offer for sale that the equipment is subject to the FCC rules and that the equipment will comply with the appropriate rules before delivery to the buyer or to centers of distribution.

- (e)(1) Notwithstanding the provisions of paragraph (a) of this section, prior to equipment authorization or determination of compliance with the applicable technical requirements any radio frequency device may be operated, but not marketed, for the following purposes and under the following conditions:
- (i) *Compliance testing*;
 - (ii) Demonstrations at a trade show provided the notice contained in paragraph (c) of this section is displayed in a conspicuous location on, or immediately adjacent to, the device;
 - (iii) Demonstrations at an exhibition conducted at a business, commercial, industrial, scientific or medical location, but excluding locations in a residential environment, provided the notice contained in paragraphs (c) or (d) of this section, as appropriate, is displayed in a conspicuous location on, or immediately adjacent to, the device;
 - (iv) Evaluation of product performance and determination of customer acceptability, provided such operation takes place at the manufacturer's facilities during developmental, design or pre-production states; or
 - (v) Evaluation of product performance and determination of customer acceptability where customer acceptability of a radio frequency device cannot be determined at the manufacturer's facilities because of size or unique capability of the device, provided the device is operated at a business, commercial, industrial, scientific or medical user's site, but not at a residential site, during the development, design or pre-production stages.
- (e)(2) For the purpose of paragraphs (e)(1)(iv) and (e)(1)(v) of this section, the term *manufacturer's facilities* includes the facilities of the party responsible for compliance with the regulations and the manufacturer's premises, as well as the facilities of other entities working under the authorization of the responsible party in connection with the development and manufacture, but not the marketing, of the equipment.
- (f) For radio frequency devices subject to verification and sold solely to business, commercial, industrial, scientific and medical users (excluding products sold to other parties or for operation in a residential environment), parties responsible for verification of the devices shall have the option of ensuring compliance with the applicable technical specifications of this chapter at each end user's location after installation, provided that the purchase or lease agreement includes a proviso that such a determination of compliance be made and is the responsibility of the party responsible for verification of the equipment.

Certification & User's Manual Information

The following is extracted from Title 47 of the Code of Federal Regulations, Part 2, Subpart J — Equipment Authorization Procedures:

§ 2.901 Basis and Purpose

- (a) In order to carry out its responsibilities under the Communications Act and the various treaties and international regulations, and in order to promote efficient use of the radio spectrum, the Commission has developed technical standards for radio frequency equipment and parts or components thereof. The technical standards applicable to individual types of equipment are found in that part of the rules governing the service wherein the equipment is to be operated.¹ *In addition to the technical standards provided, the rules governing the service may require that such equipment be verified by the manufacturer or importer, be authorized under a Declaration of Conformity, or receive an equipment authorization from the Commission by one of the following procedures: certification or registration.*
- (b) The following sections describe the verification procedure, the procedure for a Declaration of Conformity, and the procedures to be followed in obtaining certification from the Commission and the conditions attendant to such a grant.

§ 2.907 Certification.

- (a) Certification is an equipment authorization issued by the Commission, based on representation and test data submitted by the applicant.
- (b) Certification attaches to all units subsequently marketed by the grantee which are identical (see Section 2.908) to the sample tested except for permissive changes or other variations authorized by the Commission pursuant to Section 2.1043.

¹ In this case, the equipment is subject to the rules of Part 15. More specifically, the equipment falls under Subpart B (of Part 15), which deals with unintentional radiators.

Certification & User's Manual Information

§ 2.948 Description of measurement facilities.

- (a) Each party making measurements of equipment that is subject to an equipment authorization under Part 15 or Part 18 of this chapter, regardless of whether the measurements are filed with the Commission or kept on file by the party responsible for compliance of equipment marketed within the U.S. or its possessions, shall compile a description of the measurement facilities employed.
- (1) If the measured equipment is subject to the verification procedure, the description of the measurement facilities shall be retained by the party responsible for verification of the equipment.
- (i) *If the equipment is verified through measurements performed by an independent laboratory, it is acceptable for the party responsible for verification of the equipment to rely upon the description of the measurement facilities retained by or placed on file with the Commission by that laboratory. In this situation, the party responsible for the verification of the equipment is not required to retain a duplicate copy of the description of the measurement facilities.*
- (ii) If the equipment is verified based on measurements performed at the installation site of the equipment, no specific site calibration data is required. It is acceptable to retain the description of the measurement facilities at the site at which the measurements were performed.
- (2) If the equipment is to be authorized by the Commission under the certification procedure, the description of the measurement facilities shall be filed with the Commission's Laboratory in Columbia, Maryland. The data describing the measurement facilities need only be filed once but must be updated as changes are made to the measurement facilities or as otherwise described in this section. At least every three years, the organization responsible for filing the data with the Commission shall certify that the data on file is current.

Certification & User's Manual Information

1. Label and User's Manual Information

The following is extracted from Title 47 of the Code of Federal Regulations, Part 15, Subpart A — General:

§ 15.19 Labeling requirements.

(a) *In addition to the requirements in Part 2 of this chapter, a device subject to certification or verification shall be labeled as follows:*

- (1) Receivers associated with the operation of a licensed radio service, e.g., FM broadcast under Part 73 of this chapter, land mobile operation under Part 90, etc., shall bear the following statement in a conspicuous location on the device:

This device complies with Part 15 of the FCC Rules. Operation is subject to the condition that this device does not cause harmful interference.

- (2) A stand-alone cable input selector switch, shall bear the following statement in a conspicuous location on the device:

This device is verified to comply with Part 15 of the FCC Rules for use with cable television service.

- (3) All other devices shall bear the following statement in a conspicuous location on the device:

This device complies with Part 15 of the FCC Rules. Operation is subject to the following two conditions: (1) This device may not cause harmful interference, and (2) this device must accept any interference received, including interference that may cause undesired operation.

- (4) Where a device is constructed in two or more sections connected by wires and marketed together, the statement specified under paragraph (a) of this section is required to be affixed only to the main control unit.

- (5) When the device is so small or for such use that it is not practicable to place the statement specified under paragraph (a) of this section on it, the information required by this paragraph shall be placed in a prominent location in the instruction manual or pamphlet supplied to the user or, alternatively, shall be placed on the container in which the device is marketed. However, the FCC identifier or the unique identifier, as appropriate, must be displayed on the device.

§ 15.21 Information to user.

The users manual or instruction manual for an intentional or unintentional radiator shall caution the user that changes or modifications not expressly approved by the party responsible for compliance could void the user's authority to operate the equipment.

Verification & User's Manual Information

The following is extracted from Title 47 of the Code of Federal Regulations, Part 15, Subpart B — Unintentional Radiators:

§ 15.105 Information to the user.

- (a) For a Class A digital device or peripheral, the instructions furnished the user shall include the following or similar statement, placed in a prominent location in the text of the manual:

Note: This equipment has been tested and found to comply with the limits for a Class A digital device, pursuant to Part 15 of the FCC Rules. These limits are designed to provide reasonable protection against harmful interference when the equipment is operated in a commercial environment. This equipment generates, uses, and can radiate radio frequency energy and, if not installed and used in accordance with the instruction manual, may cause harmful interference to radio communications. Operation of this equipment in a residential area is likely to cause harmful interference in which case the user will be required to correct the interference at own expense.

- (b) For a Class B digital device or peripheral, the instructions furnished the user shall include the following or similar statement, placed in a prominent location in the text of the manual:

Note: This equipment has been tested and found to comply with the limits for a Class B digital device, pursuant to Part 15 of the FCC Rules. These limits are designed to provide reasonable protection against harmful interference when the equipment is operated in a residential environment. This equipment generates, uses, and can radiate radio frequency energy and, if not installed and used in accordance with the instruction manual, may cause harmful interference to radio communications. However, there is no guarantee that interference will not occur in a particular installation. If this equipment does cause harmful interference to radio or television reception, which can be determined by turning the equipment off and on, the user is encouraged to try to correct the interference by one or more of the following measures:

- Reorient or relocate the receiving antenna.
- Increase the separation between the equipment and receiver.
- Connect the equipment into an outlet on a circuit different from that to which the receiver is connected.
- Consult the dealer or an experienced radio/TV technician for help.

ICES-003 Procedural & Labeling Requirements

From the Industry Canada Electromagnetic Compatibility Advisory Bulletin entitled, "Implementation and Interpretation of the Interference-Causing Equipment Standard for Digital Apparatus, ICES-003" (EMCAB-3, Issue 2, July 1995):

"At present, CISPR 22: 2002 and ICES technical requirements are essentially equivalent. Therefore, if you have CISPR 22: 2002 approval by meeting CISPR Publication 22, the only additional requirements are: to attach a note to the report of the test results for compliance, indicating that these results are deemed satisfactory evidence of compliance with ICES-003 of the Canadian Interference-Causing Equipment Regulations; to maintain these records on file for the requisite five year period; and to provide the device with a notice of compliance in accordance with ICES-003."

Procedural Requirements:

According to Industry Canada's Interference Causing Equipment Standard for Digital Apparatus ICES-003 Issue 4, February 2004:

- Section 6.1: A record of the measurements and results, showing the date that the measurements were completed, shall be retained by the manufacturer or importer for a period of at least five years from the date shown in the record and made available for examination on the request of the Minister.
- Section 6.2: A written notice indicating compliance must accompany each unit of digital apparatus to the end user. The notice shall be in the form of a label that is affixed to the apparatus. Where because of insufficient space or other constraints it is not feasible to affix a label to the apparatus, the notice may be in the form of a statement in the user's manual.

Labeling Requirements:

The suggested text for the notice, in English and in French, is provided below, from the Annex of ICES-003:

This Class [²] digital apparatus complies with Canadian ICES-003.

Cet appareil numérique de la classe [¹] est conforme à la norme NMB-003 du Canada.

² Insert either A or B but not both as appropriate for the equipment requirements.

End of Report