



427 West 12800 South
Draper, UT 84020

Test Report Certification

FCC ID	SWX-LBE5ACXR
IC ID	6545A-LBE5ACXR
Equipment Under Test	LBE-5AC-XR
Test Report Serial Number	TR6310_01
Date of Test(s)	22, 24, and 29 June; 7 July 2021
Report Issue Date	27 July 2021

Test Specification	Applicant
47 CFR FCC Part 15, Subpart C	Ubiquiti Inc. 685 Third Avenue New York, NY 10019 U.S.A.



NVLAP LAB CODE 600241-0

Certification of Engineering Report

This report has been prepared by Unified Compliance Laboratory (UCL) to document compliance of the device described below with the requirement of Federal Communication Commissions (FCC) Part 15, Subpart C. This report may be reproduced in full. Partial reproduction of this report may only be made with the written consent of the laboratory. The results in this report apply only to the sample tested.

Applicant	Ubiquiti Inc.
Manufacturer	Ubiquiti Inc.
Brand Name	airMAX
Model Number	LBE-5AC-XR
FCC ID	SWX-LBE5ACXR
IC ID	6545A-LBE5ACXR

On this 27th day of July 2021, I individually and for Unified Compliance Laboratory certify that the statements made in this engineering report are true, complete, and correct to the best of my knowledge and are made in good faith.

Although NVLAP has accredited the Unified Compliance Laboratory testing facilities, this report must not be used to claim product certification, approval, or endorsement by NVLAP, NIST or any agency of the U.S. federal government.

Unified Compliance Laboratory



Written By: Joseph W. Jackson



Reviewed By: Richard L. Winter

Revision History		
Revision	Description	Date
01	Original Report Release	27 July 2021

Table of Contents

1	Client Information.....	5
1.1	Applicant.....	5
1.2	Manufacturer.....	5
2	Equipment Under Test (EUT).....	6
2.1	Identification of EUT	6
2.2	Description of EUT	6
2.3	EUT and Support Equipment.....	6
2.4	Interface Ports on EUT	7
2.5	Operating Environment.....	7
2.6	Operating Modes.....	7
2.7	EUT Exercise Software.....	7
2.8	Block Diagram of Test Configuration	7
2.9	Modification Incorporated/Special Accessories on EUT.....	8
2.10	Deviation, Opinions Additional Information or Interpretations from Test Standard.....	8
3	Test Specification, Method and Procedures.....	9
3.1	Test Specification.....	9
3.2	Methods & Procedures.....	9
3.3	FCC Part 15, Subpart C	9
3.4	Results.....	10
3.5	Test Location	10
4	Test Equipment	11
4.1	Conducted Emissions at Mains Ports.....	11
4.2	Direct Connect at the Antenna Port Tests.....	11
4.3	Radiated Emissions.....	12
4.4	Equipment Calibration	12
4.5	Measurement Uncertainty.....	13
5	Test Results.....	14
5.1	§15.203 Antenna Requirements.....	14
5.2	Conducted Emissions at Mains Ports Data	14
5.3	§15.247(a)(2)	16
5.4	§15.247(b)(3) Maximum Average Output Power.....	16
5.5	§15.247(d) Spurious Emissions	17
5.6	§15.247(e) Maximum Average Power Spectral Density	24

1 Client Information

1.1 Applicant

Company	Ubiquiti Inc. 685 Third Avenue New York, NY 10017 U.S.A.
Contact Name	Mark Feil
Title	Compliance Manager

1.2 Manufacturer

Company	Ubiquiti Inc. 685 Third Avenue New York, NY 10017 U.S.A.
Contact Name	Mark Feil
Title	Compliance Manager

2 Equipment Under Test (EUT)

2.1 Identification of EUT

Brand Name	airMAX
Model Number	LBE-5AC-XR
Serial Number	0418D6A2AFB9
Dimensions (cm)	74.7 x 52.5 x 34.7

2.2 Description of EUT

The LBE-5AC-XR is a point-to-point transceiver, intended for outdoor use, operating in the 5 GHz WiFi, UNII-1, UNII-2A/2C and UNII-3 frequency bands. The LBE-5AC-XR is designed to be lightweight and aimed to create extremely long-distance wireless links. The LBE-5AC-XR also has a Bluetooth LE transceiver for device management. An Ethernet port is used for data transfer and to provide power using a POE-24-24W POE power supply.

This report covers the circuitry of the device subject to FCC Part 15, Subpart C. The circuitry of the device subject to FCC Part 15 Subpart B was found to be compliant and is covered under a separate Unified Compliance Laboratory test report.

2.3 EUT and Support Equipment

The EUT and support equipment used during the test are listed below.

Brand Name Model Number Serial Number	Description	Name of Interface Ports / Interface Cables
BN: airMAX MN: LBE5AC-XR (Note 1) SN: 0418D6A2AFB9	Wireless Transceiver	See Section 2.4
BN: Ubiquiti Inc. MN: POE-24-24W (Note 1) SN: None	POE Supply	POE Port See Section 2.4
BN: Dell MN: XPS 13 SN: None	Laptop PC	LAN Port / Shielded or Unshielded Cat 5e cable (Note 2)
BN: HP MN: Spectre SN: None	Laptop PC	LAN Port / Shielded or Unshielded Cat 5e cable (Note 2)

Notes: (1) EUT

(2) Interface port connected to EUT (See Section 2.4)

The support equipment listed above was not modified in order to achieve compliance with this standard.

2.4 Interface Ports on EUT

Name of Ports	No. of Ports Fitted to EUT	Cable Description/Length
AC (PoE Injector)	1	3 conductor power cord/80cm
LAN (PoE Injector)	1	Shielded or Unshielded Cat 5e cable/1 meter
Data	1	Shielded or Unshielded Cat 5e cable/8meters

2.5 Operating Environment

Power Supply	120 Vac to 24 Volt PoE Power
AC Mains Frequency	60 Hz
Temperature	16.7 – 32.8 °C
Humidity	26.39 – 56.4 %
Barometric Pressure	1017 mBar

2.6 Operating Modes

The LBE-5AC-XR was connected to a personal computer laptop and tested using test software in order to enable to constant duty cycle of the Bluetooth transceiver. The measurements within this report are corrected to reference a 100% duty cycle.

2.7 EUT Exercise Software

EUT firmware version 1.0 was used to operate the transmitter using a constant transmit mode.

2.8 Block Diagram of Test Configuration

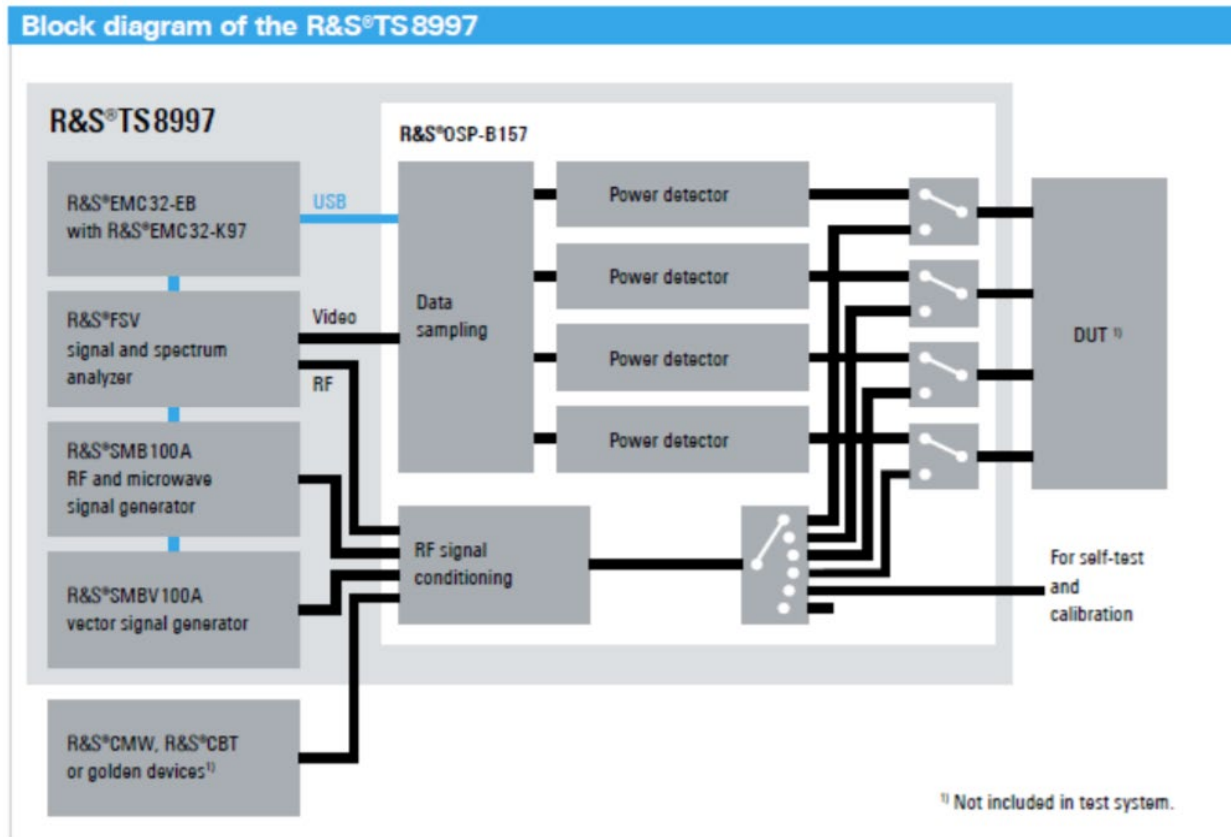

Diagram 1: Test Configuration Block Diagram

2.9 Modification Incorporated/Special Accessories on EUT

There were no modifications made to the EUT during testing to comply with the specification.

2.10 Deviation, Opinions Additional Information or Interpretations from Test Standard

There were no deviations, opinions, additional information or interpretations from the test specification.

3 Test Specification, Method and Procedures

3.1 Test Specification

Title	47 CFR FCC Part 15, Subpart C 15.203, 15.207 and 15.247 Limits and methods of measurement of radio interference characteristics of radio frequency devices.
Purpose of Test	The tests were performed to demonstrate initial compliance

3.2 Methods & Procedures

3.2.1 47 CFR FCC Part 15 Section 15.203

See test standard for details.

3.2.2 47 CFR FCC Part 15 Section 15.207

See test standard for details.

3.2.3 47 CFR FCC Part 15 Section 15.247

See test standard for details.

3.3 FCC Part 15, Subpart C

3.3.1 Summary of Tests

FCC Section	ISED Section	Environmental Phenomena	Frequency Range (MHZ)	Result
15.203	N/A	Antenna requirements	Structural Requirement	Compliant
15.207	RSS-Gen	Conducted Disturbance at Mains Port	0.15 to 30	Compliant
15.247(a)	RSS-247 § 5.2	Bandwidth Requirement	2400 to 2483.5	Compliant
15.247(b)	RSS-247 § 5.4	Peak Output Power	2400 to 2483.5	Compliant
15.247(d)	RSS-247 § 5.4	Antenna Conducted Spurious Emissions	0.009 to 26000	N/A
15.247(d)	RSS-247 § 5.4	Radiated Spurious Emissions	0.009 to 26000	Compliant
15.247(e)	RSS-247 § 5.2	Peak Power Spectral Density	2400 to 2483.5	Compliant

The testing was performed according to the procedures in ANSI C63.10-2013, KDB 558074 and 47 CFR Part 15. Where applicable, KDB 662911 was followed to sum required measurements.

3.4 Results

In the configuration tested, the EUT complied with the requirements of the specification.

3.5 Test Location

Testing was performed at the Unified Compliance Laboratory 3-Meter and 10-Meter chambers located at 427 West 12800 South, Draper, UT 84020. Unified Compliance Laboratory is accredited by National Voluntary Laboratory Accreditation Program (NVLAP); NVLAP Code 600241-0 which is effective until 30 June 2022. This site has also been registered with Innovations, Science and Economic Development (ISED) department and was accepted under Appendix B, Phase 1 procedures of the APEC Tel MRA for Canadian recognition. ISED No.: 25346, effective until 30 June 2022. Unified Compliance Laboratory has been assigned Conformity Assessment Number US0223 by ISED.

4 Test Equipment

4.1 Conducted Emissions at Mains Ports

Type of Equipment	Manufacturer	Model Number	Asset Number	Date of Last Calibration	Due Date of Calibration
EMI Receiver	AFJ	FFT3010	UCL-2500	9/18/2020	9/17/2021
LISN	AFJ	LS16C/10	UCL-2512	5/26/2020	5/26/2022
Cat6 ISN	Teseq	ISN T8-Cat6	UCL-2971	5/18/2020	5/18/2022
ISN	Teseq	ISN T800	UCL-2974	6/4/2021	6/4/2022
LISN	Com-Power	LIN-120C	UCL-2612	5/19/2021	5/19/2022
AC Power Source	Laplace Instruments	AC1000A	UCL-2857	N/A	N/A
Test Software	UCL	Revision 1	UCL-3107	N/A	N/A

Table 1: List of equipment used for Conducted Emissions Testing at Mains Port

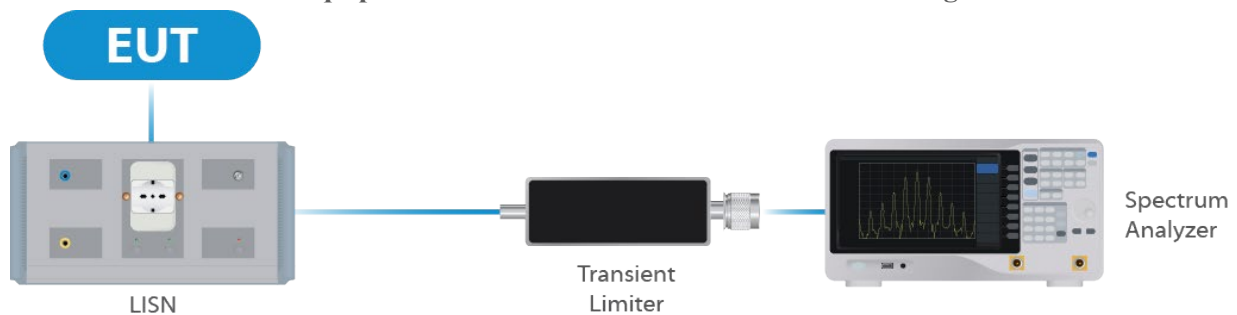

Figure 1: Conducted Emissions Test

4.2 Direct Connect at the Antenna Port Tests

Type of Equipment	Manufacturer	Model Number	Asset Number	Date of Last Calibration	Due Date of Calibration
Spectrum Analyzer	R&S	FSV40	UCL-2861	8/24/2020	8/24/2021
Signal Generator	R&S	SMB100A	UCL-2864	N/A	N/A
Vector Signal Generator	R&S	SMBV100A	UCL-2873	N/A	N/A
Switch Extension	R&S	OSP-B157WX	UCL-2867	9/8/2020	9/8/2021
Switch Extension	R&S	OSP-150W	UCL-2870	3/3/2021	3/3/2022

Table 2: List of equipment used for Direct Connect at the Antenna Port

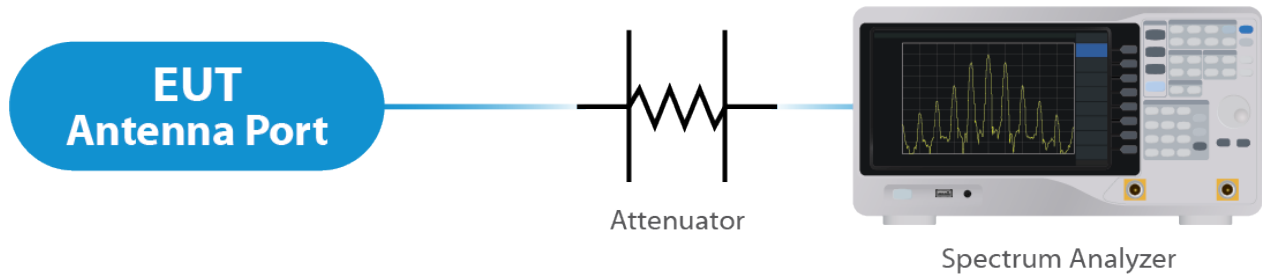

Figure 2: Direct Connect at the Antenna Port Test

4.3 Radiated Emissions

Type of Equipment	Manufacturer	Model Number	Asset Number	Date of Last Calibration	Due Date of Calibration
EMI Receiver	Keysight	N9038A	UCL-2778	6/1/2021	6/21/2022
Pre-Amplifier 9 kHz – 1 GHz	Sonoma Instruments	310N	UCL-2889	9/10/2020	9/10/2021
Double Ridge Horn Antenna	Scwarzbeck	BBHA 9120D	UCL-3065	7/8/2021	7/8/2022
Log Periodic	Scwarzbeck	STLP 9129	UCL-3068	11/16/2020	11/16/2021
15 - 40 GHz Horn Antenna	Scwarzbeck	BBHA 9170	UCL-2487	5/21/2020	5/21/2022
1 – 18 GHz Amplifier	Com-Power	PAM 118A	UCL-3833	9/29/2020	9/29/2021
Test Software	UCL	Revision 1	UCL-3108	N/A	N/A

Table 3: List of equipment used for Radiated Emissions

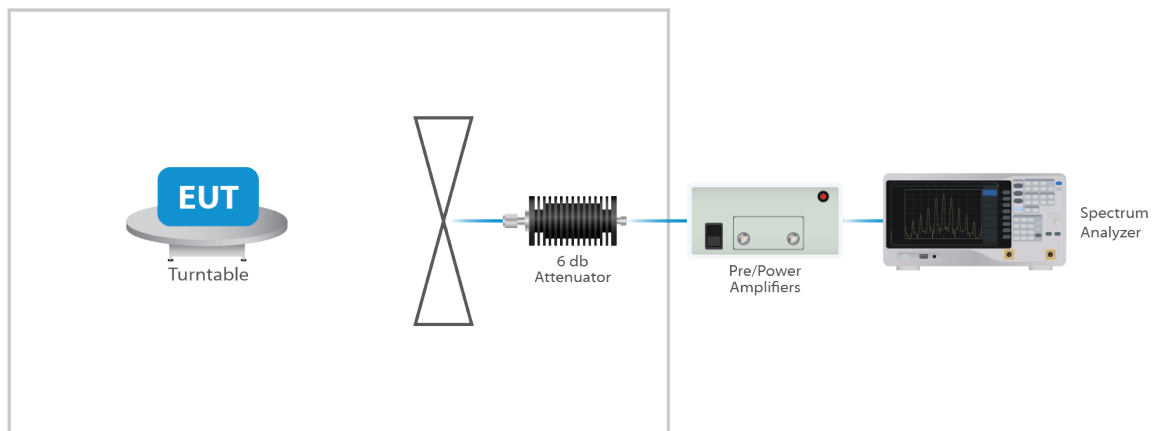

Figure 3: Radiated Emissions Test

4.4 Equipment Calibration

All applicable equipment is calibrated using either an independent calibration laboratory or Unified Compliance Laboratory personnel at intervals defined in ANSI C63.4:2014 following outlined calibration

procedures. All measurement instrumentation is traceable to the National Institute of Standards and Technology (NIST). Supporting documentation relative to traceability is on file and is available for examination upon request.

4.5 Measurement Uncertainty

Test	Uncertainty (\pm dB)	Confidence (%)
Conducted Emissions	1.44	95
Radiated Emissions (9 kHz to 30 MHz)	2.50	95
Radiated Emissions (30 MHz to 1 GHz)	4.38	95
Radiated Emissions (1 GHz to 18 GHz)	4.37	95
Radiated Emissions (18 GHz to 40 GHz)	3.93	95
Direct Connect Tests	K Factor	Value
Emissions Bandwidth	2	2.0%
Output Power	2	1.0 dB
Peak Power Spectral Density	2	1.3 dB
Band Edge	2	0.8 dB
Transmitter Spurious Emissions	2	1.8 dB

5 Test Results

5.1 §15.203 Antenna Requirements

The EUT uses an integral antenna. The Maximum gain of the antenna is 5.1 dBi. The antenna is not user replaceable.

Results

The EUT complied with the specification

5.2 Conducted Emissions at Mains Ports Data

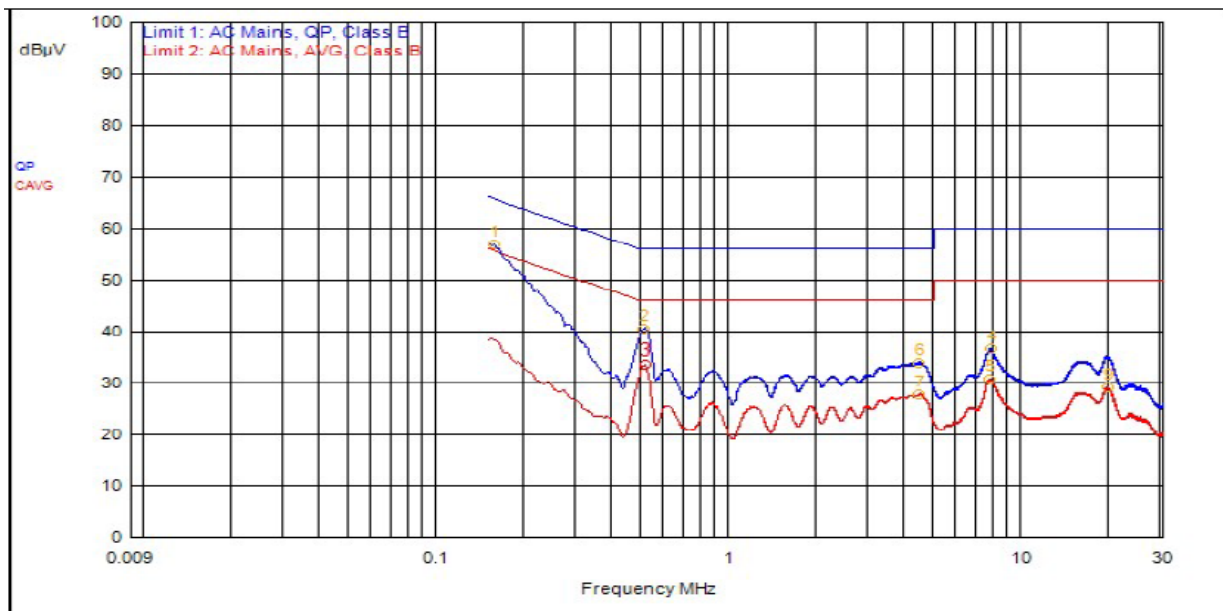

ID	Frequency	Probe	Cable	Atten.	Detector	Meter Read	Meas Level	Limit 1	Limit 1 Dist.	Limit 2	Limit 2 Dist.
1	156,000kHz	12.4	0.0		QPeak	44.5	56.9	65.7	-8.8		
2	507,000kHz	12.4	0.0		QPeak	28.2	40.6	56.0	-15.4		
6	4.407MHz	12.3	0.1		QPeak	21.6	34.0	56.0	-22.0		
4	7.719MHz	12.3	0.2		QPeak	24.1	36.6	60.0	-23.4		
3	510,000kHz	12.4	0.0		C_AVG	21.0	33.5			46.0	-12.5
5	7.686MHz	12.3	0.2		C_AVG	18.3	30.8			50.0	-19.2
7	4.419MHz	12.3	0.1		C_AVG	15.5	27.9			46.0	-18.1
9	19.401MHz	12.2	0.2		C_AVG	16.8	29.2			50.0	-20.8

Graph 1: Conducted Emissions Plot - Neutral

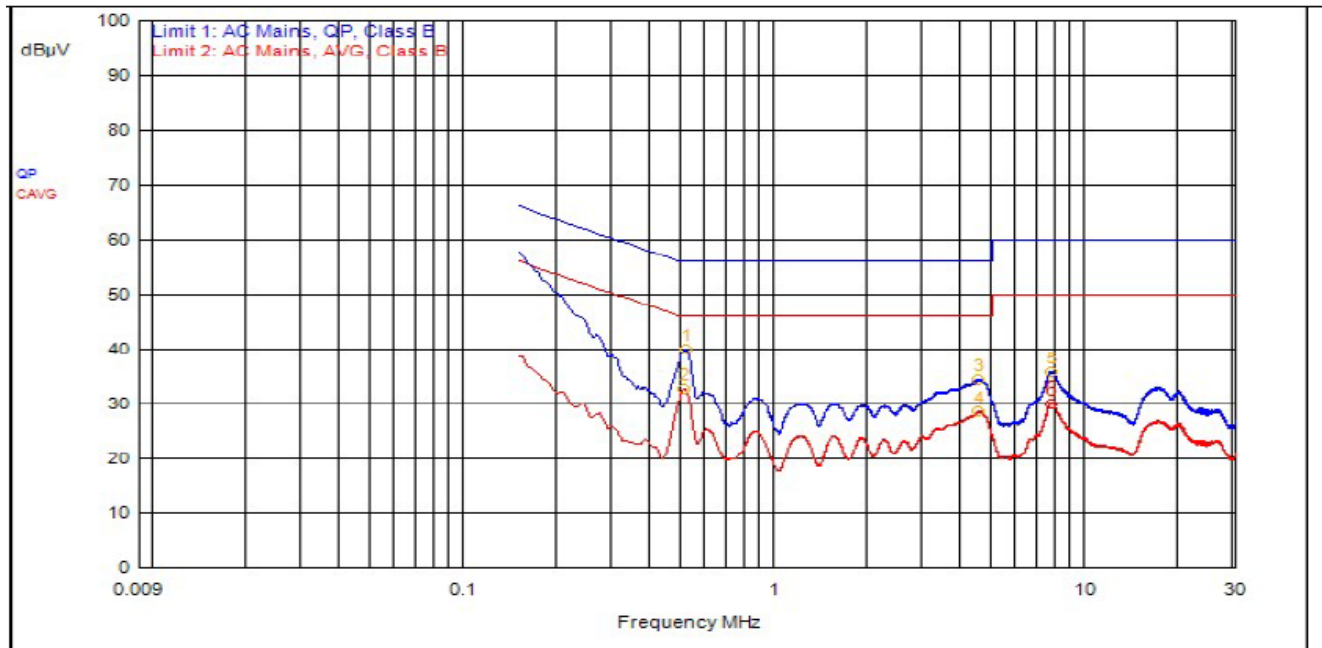

ID	Frequency	Probe	Cable	Atten.	Detector	Meter Read	Meas Level	Limit 1	Limit 1 Dist.	Limit 2	Limit 2 Dist.
1	510,000kHz	12.4	0.0		QPeak	27.5	39.9	56.0	-16.1		
3	4.437MHz	12.3	0.1		QPeak	22.0	34.4	56.0	-21.6		
5	7.686MHz	12.3	0.2		QPeak	23.4	35.9	60.0	-24.1		
2	507,000kHz	12.4	0.0		C_AVG	20.4	32.8			46.0	-13.2
4	4.467MHz	12.3	0.1		C_AVG	16.1	28.5			46.0	-17.5
6	7.611MHz	12.3	0.2		C_AVG	17.6	30.1			50.0	-19.9

Graph 2: Conducted Emissions Plot – Line 1

Result

The EUT complied with the specification limit.

5.3 §15.247(a)(2) Emissions Bandwidth

Frequency (MHz)	Emissions 6 dB Bandwidth (MHz)	Emissions 99% Bandwidth (MHz)
2402	0.67	1.00
2442	0.69	0.99
2480	0.67	0.99

Result

In the configuration tested, the 6 dB bandwidth was greater than 500 kHz; therefore, the EUT complied with the requirements of the specification (see spectrum analyzer plot within the Annex).

5.4 §15.247(b)(3) Maximum Average Output Power

The maximum average RF conducted output power measured for this device was 7.71 dBm or 5.90 mW. The limit is 30 dBm or 1 Watt when using antennas with 6 dBi or less gain. The antenna has a gain of 5.1 dBi.

Frequency (MHz)	Measured Output Power (dBm)	Output Power (mW)
2402	6.00	3.98
2442	7.09	5.12
2480	7.71	5.90

Result

In the configuration tested, the maximum average RF output power was less than 1 watt; therefore, the EUT complied with the requirements of the specification (see spectrum analyzer plot within the Annex).

5.5 §15.247(d) Spurious Emissions

5.5.1 Conducted Spurious Emissions

The frequency range from the lowest frequency generated or used in the device to the tenth harmonic of the highest fundamental frequency was investigated to measure any antenna-conducted emissions. The table show the measurement data from spurious emissions noted across the frequency range when transmitting at the lowest frequency, middle frequency and upper frequency. Shown within the Annex are plot(s) with the EUT tuned to the upper and lower channels. These demonstrate compliance with the provisions of this section at the band edges.

The emissions must be attenuated 30 dB below the highest power spectral density level measured within the authorized band as measured with a 100 kHz RBW.

Result

Conducted spurious emissions were attenuated 30 dB or more below the fundamental; therefore, the EUT complies with the specification.

5.5.2 Radiated Spurious Emissions in the Restricted Bands of §15.205

The frequency range from the lowest frequency generated or used in the device to the tenth harmonic of the highest fundamental emissions was investigated to measure any radiated emissions in the restricted bands. The following tables show measurements of any emissions that fell into the restricted bands of §15.205. The tables show the worst-case emissions measured from the EUT. For frequencies above 18.0 GHz, a measurement distance of 1 meter was used. The noise floor was a minimum of 6 dB below the limits. The emissions in the restricted bans must meet the limits specified in §15.209. Tabular data for each of the spurious emissions is shown below for each of the units. Plots of the band edges are also shown.

Result

All emissions in the restricted bands of §15.205 met the limits specified in §15.209; therefore, the EUT complies with the specification.

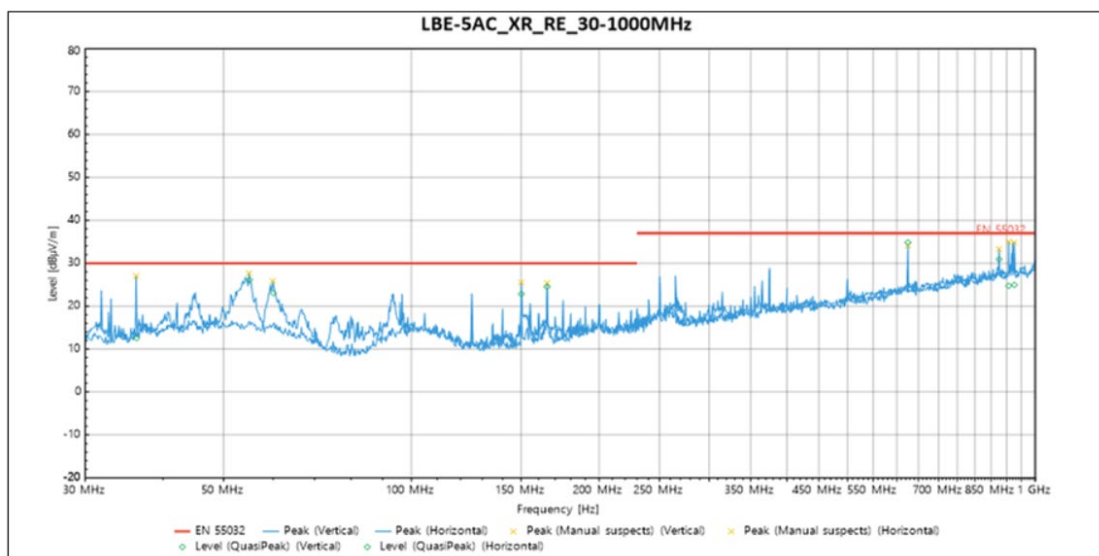

Vertical

Source	Frequency	Level (dB μ V/m)	Limit (dB μ V/m)	Margin	Azimuth (°)	Height	Pol.	Correction (dB)
QuasiPeak	36.268 MHz	12.547	30	-17.453	246	0.995	Vertical	-14.359
QuasiPeak	55.037 MHz	26.11	30	-3.89	31	3.661	Vertical	-12.734
QuasiPeak	60.067 MHz	23.037	30	-6.963	110	3.442	Vertical	-13.432
QuasiPeak	150.02 MHz	22.839	30	-7.161	59	1.167	Vertical	-17.799
QuasiPeak	164.98 MHz	24.483	30	-5.517	213	1.034	Vertical	-16.827
QuasiPeak	906.67 MHz	24.727	37	-12.273	328	3.059	Vertical	-0.573
QuasiPeak	925.77 MHz	24.963	37	-12.037	309	1.735	Vertical	0.037

Horizontal

Source	Frequency	Level (dB μ V/m)	Limit (dB μ V/m)	Margin	Azimuth (°)	Height	Pol.	Correction (dB)
QuasiPeak	625 MHz	34.856	37	-2.144	153	1.362	Horizontal	-4.944
QuasiPeak	875.04 MHz	30.931	37	-6.069	133	1.125	Horizontal	-1.207

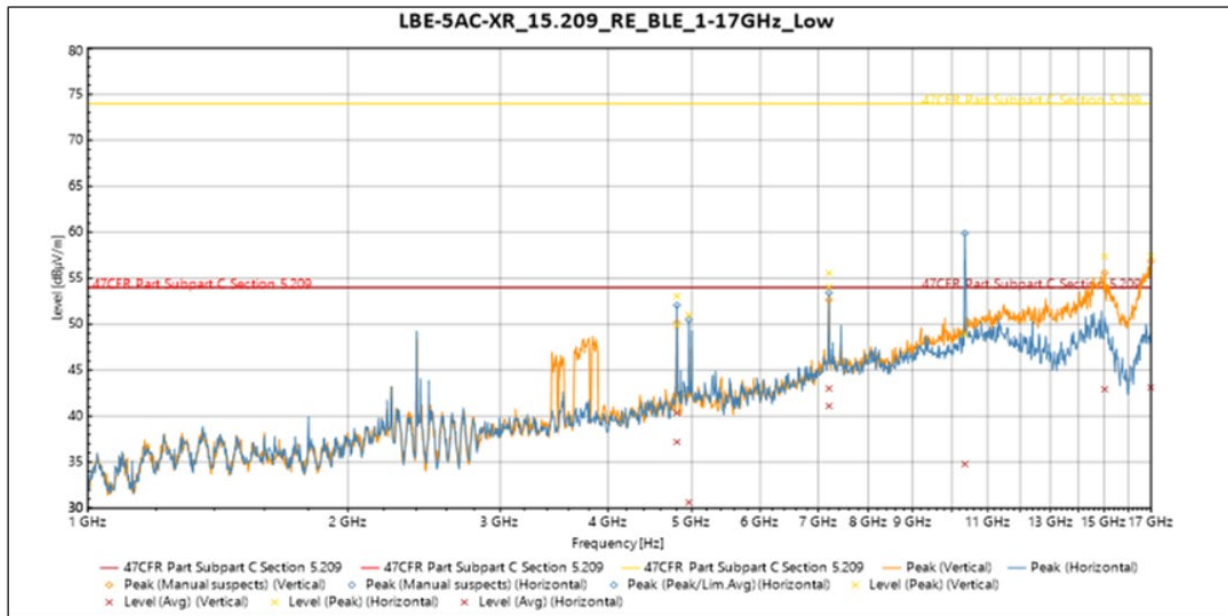
Table 4: Radiated Emissions 30 – 1000 MHz

Vertical

Source	Frequency	Level (dB μ V/m)	Limit (dB μ V/m)	Margin (dB)	Azimuth (°)	Height (m)	Pol.	Correction (dB)
Peak	4.8044 GHz	49.855	74	-24.145	265	2.811	Vertical	-8.392
Peak	7.2067 GHz	54.043	74	-19.957	37	2.32	Vertical	-2.386
Peak	15.022 GHz	57.366	74	-16.634	280	4	Vertical	10.275
Peak	16.995 GHz	57.435	74	-16.565	134	2.32	Vertical	11.454

Source	Frequency	Level (dB μ V/m)	Limit (dB μ V/m)	Margin (dB)	Azimuth (°)	Height (m)	Pol.	Correction (dB)
Avg	4.8044 GHz	37.193	54	-16.807	265	2.811	Vertical	-8.392
Avg	7.2067 GHz	41.11	54	-12.89	37	2.32	Vertical	-2.386
Avg	15.022 GHz	42.924	54	-11.076	280	4	Vertical	10.275
Avg	16.995 GHz	43.12	54	-10.88	134	2.32	Vertical	11.454

Horizontal

Source	Frequency	Level (dBµV/m)	Limit (dBµV/m)	Margin (dB)	Azimuth (°)	Height (m)	Pol.	Correction (dB)
Peak	4.8045 GHz	53.058	74	-20.942	57	2.321	Horizontal	-8.393
Peak	4.9596 GHz	50.986	74	-23.014	77	2.151	Horizontal	-8.464
Peak	7.2067 GHz	55.568	74	-18.432	316	2.151	Horizontal	-2.386
Peak	10.351 GHz	48.904	74	-25.096	153	1.643	Horizontal	3.512

Source	Frequency	Level (dBµV/m)	Limit (dBµV/m)	Margin (dB)	Azimuth (°)	Height (m)	Pol.	Correction (dB)
Avg	4.8045 GHz	40.364	54	-13.636	57	2.321	Horizontal	-8.393
Avg	4.9596 GHz	30.62	54	-23.38	77	2.151	Horizontal	-8.464
Avg	7.2067 GHz	43.007	54	-10.993	316	2.151	Horizontal	-2.386
Avg	10.351 GHz	34.793	54	-19.207	153	1.643	Horizontal	3.512

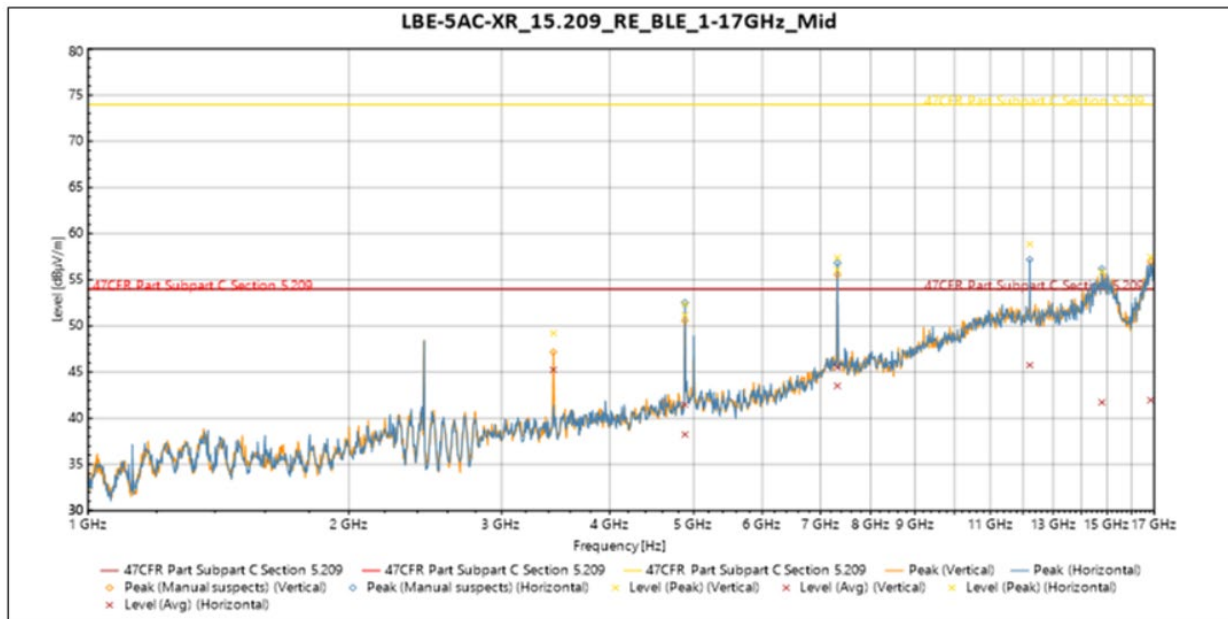
Table 4: Transmitting at the Lowest Frequency – 2402 MHz – 1 – 17 GHz

Vertical

Source	Frequency	Level (dBµV/m)	Limit (dBµV/m)	Margin (dB)	Azimuth (°)	Height (m)	Pol.	Correction (dB)
Peak	3.4433 GHz	49.214	74	-24.786	346	1.5	Vertical	-11.745
Peak	4.8839 GHz	52.348	74	-21.652	105	1.643	Vertical	-8.336
Peak	7.3252 GHz	57.411	74	-16.589	277	1.643	Vertical	-1.791
Peak	16.844 GHz	57.493	74	-16.507	45	3.662	Vertical	11.06

Source	Frequency	Level (dBµV/m)	Limit (dBµV/m)	Margin (dB)	Azimuth (°)	Height (m)	Pol.	Correction (dB)
Avg	3.4433 GHz	45.251	54	-8.749	346	1.5	Vertical	-11.745
Avg	4.8839 GHz	41.482	54	-12.518	105	1.643	Vertical	-8.336
Avg	7.3252 GHz	45.53	54	-8.47	277	1.643	Vertical	-1.791
Avg	16.844 GHz	41.959	54	-12.041	45	3.662	Vertical	11.06

Horizontal

Source	Frequency	Level (dB μ V/m)	Limit (dB μ V/m)	Margin (dB)	Azimuth (°)	Height (m)	Pol.	Correction (dB)
Peak	4.8847 GHz	51.181	74	-22.819	53	3.302	Horizontal	-8.345
Peak	7.325 GHz	56.108	74	-17.892	26	1.825	Horizontal	-1.787
Peak	12.211 GHz	58.871	74	-15.129	59	1.643	Horizontal	6.846
Peak	14.794 GHz	55.838	74	-18.162	126	2.655	Horizontal	9.375

Source	Frequency	Level (dB μ V/m)	Limit (dB μ V/m)	Margin (dB)	Azimuth (°)	Height (m)	Pol.	Correction (dB)
Avg	4.8847 GHz	38.243	54	-15.757	53	3.302	Horizontal	-8.345
Avg	7.325 GHz	43.509	54	-10.491	26	1.825	Horizontal	-1.787
Avg	12.211 GHz	45.763	54	-8.237	59	1.643	Horizontal	6.846
Avg	14.794 GHz	41.731	54	-12.269	126	2.655	Horizontal	9.375

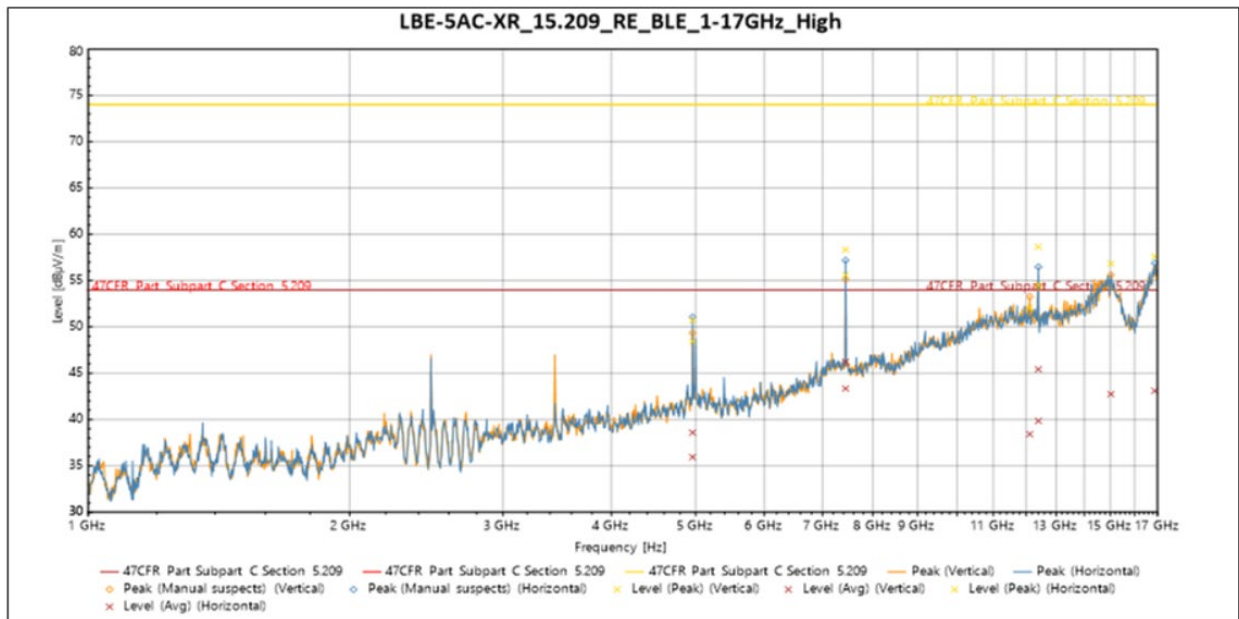
Table 5: Transmitting at the Middle Frequency – 2442 MHz – 1 – 17 GHz

Vertical

Source	Frequency	Level (dB μ V/m)	Limit (dB μ V/m)	Margin (dB)	Azimuth (°)	Height (m)	Pol.	Correction (dB)
Peak	4.9593 GHz	48.447	74	-25.553	274	2.811	Vertical	-8.469
Peak	7.4391 GHz	55.593	74	-18.407	37	1.829	Vertical	-1.947
Peak	12.117 GHz	52.064	74	-21.936	289	1.643	Vertical	6.462
Peak	12.398 GHz	54.538	74	-19.462	349	2.146	Vertical	5.989
Peak	15.026 GHz	56.84	74	-17.16	48	3.158	Vertical	10.342

Source	Frequency	Level (dB μ V/m)	Limit (dB μ V/m)	Margin (dB)	Azimuth (°)	Height (m)	Pol.	Correction (dB)
Avg	4.9593 GHz	35.937	54	-18.063	274	2.811	Vertical	-8.469
Avg	7.4391 GHz	43.339	54	-10.661	37	1.829	Vertical	-1.947
Avg	12.117 GHz	38.422	54	-15.578	289	1.643	Vertical	6.462
Avg	12.398 GHz	39.839	54	-14.161	349	2.146	Vertical	5.989
Avg	15.026 GHz	42.736	54	-11.264	48	3.158	Vertical	10.342

Horizontal

Source	Frequency	Level (dBμV/m)	Limit (dBμV/m)	Margin (dB)	Azimuth (°)	Height (m)	Pol.	Correction (dB)
Peak	4.9593 GHz	50.703	74	-23.297	42	2.812	Horizontal	-8.469
Peak	7.4391 GHz	58.339	74	-15.661	68	2.325	Horizontal	-1.947
Peak	12.399 GHz	58.651	74	-15.349	14	2.654	Horizontal	5.974
Peak	16.875 GHz	57.591	74	-16.409	39	2.65	Horizontal	12.099

Source	Frequency	Level (dBμV/m)	Limit (dBμV/m)	Margin (dB)	Azimuth (°)	Height (m)	Pol.	Correction (dB)
Avg	4.9593 GHz	38.576	54	-15.424	42	2.812	Horizontal	-8.469
Avg	7.4391 GHz	46.234	54	-7.766	68	2.325	Horizontal	-1.947
Avg	12.399 GHz	45.421	54	-8.579	14	2.654	Horizontal	5.974
Avg	16.875 GHz	43.099	54	-10.901	39	2.65	Horizontal	12.099

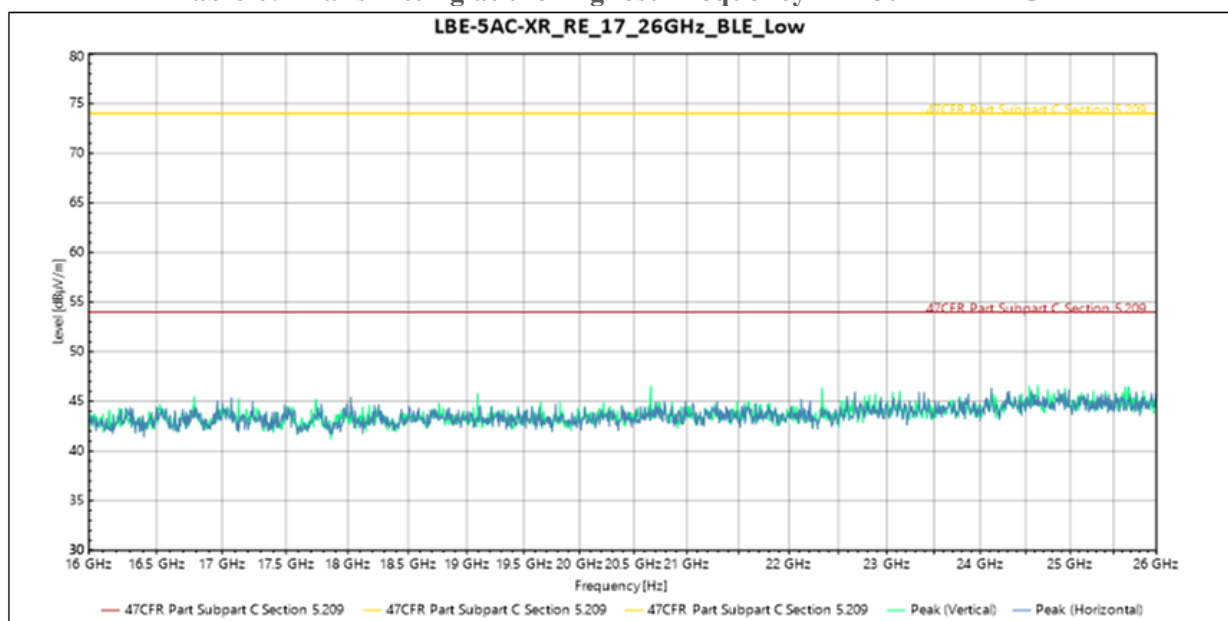
Table 6: Transmitting at the Highest Frequency – 2480 – 1 – 17 GHz

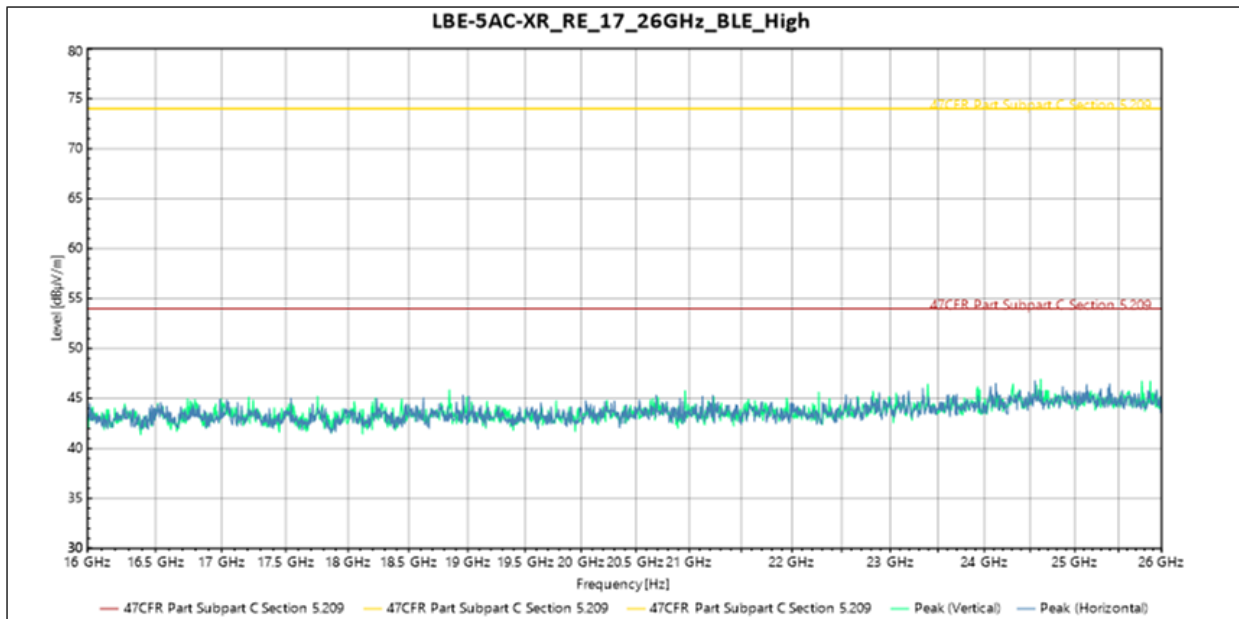
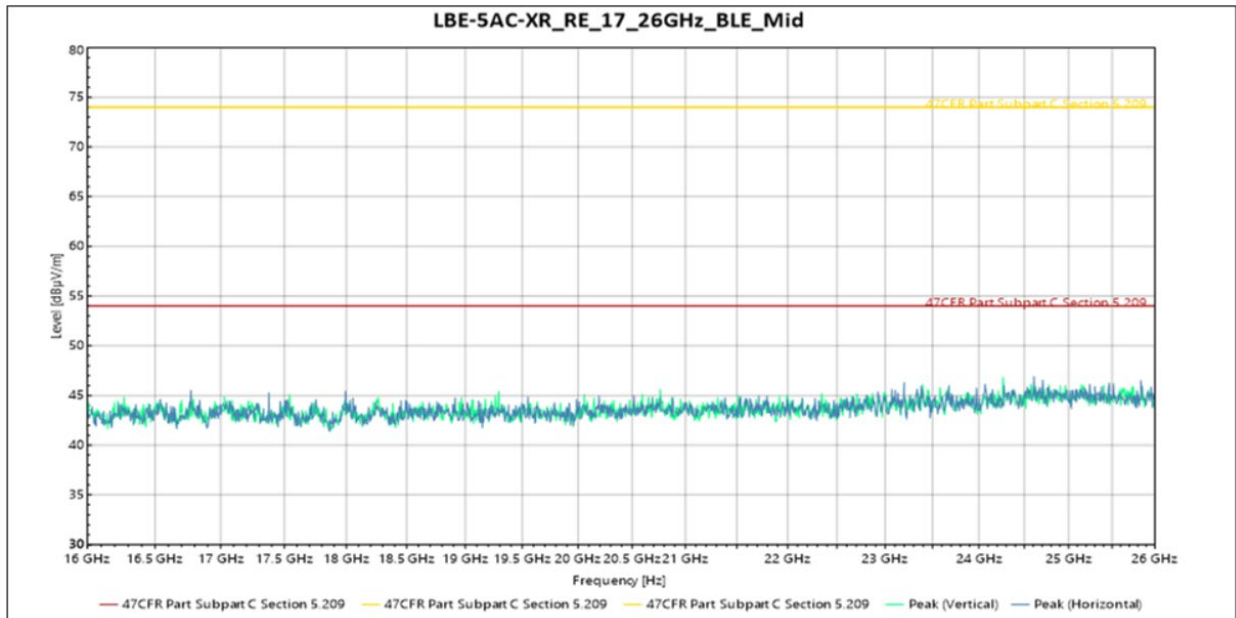

Vertical – No significant emissions were observed from 17 – 40 GHz

Horizontal – No significant emissions were observed from 17 – 40 GHz

Table 7: Radiated Emissions 17 – 40 GHz

5.6 §15.247(e) Maximum Average Power Spectral Density

The maximum average power spectral density conducted from the intentional radiator of the antenna shall not be greater than 8 dBm in any 3 kHz band during any time interval of continuous transmission. Results of this testing are summarized.

Frequency (MHz)	Measurement (dBm)	Criteria (dBm)
2402	-1.64	8.0
2442	-0.59	8.0
2480	0.02	8.0

Result

The maximum average power spectral density was less than the limit of 8 dBm; therefore, the EUT complies with the specification.

-- End of Test Report --