



**MET Laboratories, Inc.** *Safety Certification - EMI - Telecom Environmental Simulation*

914 WEST PATAPSCO AVENUE • BALTIMORE, MARYLAND 21230-3432 • PHONE (410) 354-3300 • FAX (410) 354-3313

33439 WESTERN AVENUE • UNION CITY, CALIFORNIA 94587 • PHONE (510) 489-6300 • FAX (510) 489-6372

3162 BELICK STREET • SANTA CLARA, CALIFORNIA 95054 • PHONE (408) 748-3585 • FAX (510) 489-6372

June 8, 2010

Ubiquiti Networks  
91 E. Tasman  
San Jose, CA 95134

Dear Robert Pera,

Enclosed is the EMC Wireless test report for compliance testing of the Ubiquiti Networks, E2 as tested to the requirements of Title 47 of the CFR, Ch. 1 (10-1-06 ed.), Part 15, Subpart B, ICES-003, Issue 4 February 2004 for a Class A Digital Device and FCC Part 15 Subpart C, RSS-210, Issue 7, June 2007 for Intentional Radiators.

Thank you for using the services of MET Laboratories, Inc. If you have any questions regarding these results or if MET can be of further service to you, please feel free to contact me.

Sincerely yours,  
MET LABORATORIES, INC.

Jennifer Warnell  
Documentation Department

Reference: (\Ubiquiti Networks\EMCS82107-FCC247 Rev. 1)

Certificates and reports shall not be reproduced except in full, without the written permission of MET Laboratories, Inc.

## **Electromagnetic Compatibility Criteria Test Report**

for the

**Ubiquiti Networks  
E2**

**Tested under**  
the FCC Certification Rules  
contained in  
Title 47 of the CFR, Parts 15 Subpart B & ICES-003  
for Class A Digital Devices  
&  
15.247 Subpart C & RSS-210, Issue 7, June 2007  
for Intentional Radiators

**MET Report: EMCS82107-FCC247 Rev. 1**

June 8, 2010

**Prepared For:**

**Ubiquiti Networks  
91 E. Tasman  
San Jose, CA 95134**

**Prepared By:**  
**MET Laboratories, Inc.**  
3162 Belick St.  
Santa Clara, CA 95054

## Electromagnetic Compatibility Criteria Test Report

for the

### Ubiquiti Networks E2

**Tested under**  
the FCC Certification Rules  
contained in  
Title 47 of the CFR, Parts 15 Subpart B & ICES-003  
for Class A Digital Devices  
&  
15.247 Subpart C & RSS-210, Issue 7, June 2007  
for Intentional Radiators



Anderson Soungpanya, Project Engineer  
Electromagnetic Compatibility Lab



Jennifer Warnell  
Documentation Department

**Engineering Statement:** The measurements shown in this report were made in accordance with the procedures indicated, and the emissions from this equipment were found to be within the limits applicable. I assume full responsibility for the accuracy and completeness of these measurements, and for the qualifications of all persons taking them. It is further stated that upon the basis of the measurements made, the equipment tested is capable of operation in accordance with the requirements of the FCC Rules Parts 15B, 15.247 and Industry Canada standards ICES-003, Issue 4 February 2004, RSS-210, Issue 7, June 2007 under normal use and maintenance.



Shawn McMillen,  
Wireless Manager, Electromagnetic Compatibility Lab

## Report Status Sheet

Revision	Report Date	Reason for Revision
∅	May 5, 2010	Initial Issue.
1	June 8, 2010	Revised to reflect engineer corrections.

## Table of Contents

<b>I.</b>	<b>Executive Summary .....</b>	<b>1</b>
	A. Purpose of Test .....	2
	B. Executive Summary .....	2
<b>II.</b>	<b>Equipment Configuration .....</b>	<b>3</b>
	A. Overview .....	4
	B. References .....	5
	C. Test Site .....	5
	D. Description of Test Sample .....	6
	E. Equipment Configuration .....	8
	F. Support Equipment .....	8
	G. Ports and Cabling Information .....	8
	H. Mode of Operation .....	9
	I. Method of Monitoring EUT Operation .....	9
	J. Modifications .....	9
	a) Modifications to EUT .....	9
	b) Modifications to Test Standard .....	9
	K. Disposition of EUT .....	9
<b>III.</b>	<b>Electromagnetic Compatibility Criteria for Unintentional Radiators .....</b>	<b>10</b>
	§ 15.107(a) Conducted Emissions Limits .....	11
	§ 15.109(a) Radiated Emissions Limits .....	15
<b>IV.</b>	<b>Electromagnetic Compatibility Criteria for Intentional Radiators .....</b>	<b>20</b>
	§ 15.203 Antenna Requirement .....	21
	§ 15.207(a) Conducted Emissions Limits .....	22
	§ 15.247(a) 6 dB and 99% Bandwidth .....	26
	§ 15.247(b) Peak Power Output and RF Exposure .....	37
	§ 15.247(d) Radiated Spurious Emissions Requirements and Band Edge .....	47
	RSS-GEN Receiver Spurious Emissions .....	68
	§ 15.247(d) RF Conducted Spurious Emissions Requirements and Band Edge .....	70
	§ 15.247(e) Peak Power Spectral Density .....	83
<b>V.</b>	<b>Test Equipment .....</b>	<b>90</b>
<b>VI.</b>	<b>Certification &amp; User's Manual Information .....</b>	<b>92</b>
	A. Certification Information .....	93
	B. Label and User's Manual Information .....	97
<b>VII.</b>	<b>ICES-003 Procedural &amp; Labeling Requirements .....</b>	<b>99</b>

## List of Tables

Table 1. Executive Summary of EMC Part 15.247 Compliance Testing .....	2
Table 2. EUT Summary Table .....	4
Table 3. References .....	5
Table 4. Equipment Configuration .....	8
Table 5. Support Equipment .....	8
Table 6. Ports and Cabling Information .....	8
Table 7. Conducted Limits for Radio Frequency Devices calculated from FCC Part 15 Subsections 15.107(a) (b) and 15.207(a) .....	11
Table 8. Conducted Emissions - Voltage, AC Power, Phase Line, Test Results .....	12
Table 9. Conducted Emissions - Voltage, AC Power, Neutral Line, Test Results .....	13
Table 10. Radiated Emissions Limits calculated from FCC Part 15, §15.109 (a) (b) .....	15
Table 11. Radiated Emissions Limits, Test Results, 30MHz – 2GHz FCC Limits .....	16
Table 12. Radiated Emissions Limits, Test Results, ICES-003 Limits .....	18
Table 13. Antenna List .....	21
Table 14. Conducted Limits for Intentional Radiators from FCC Part 15 § 15.207(a) .....	22
Table 15. Conducted Emissions, 15.207, Phase Line, Test Results .....	23
Table 16. Conducted Emissions, 15.207, Neutral Line, Test Results .....	24
Table 17. Occupied Bandwidth 802.11b Mode, Test Results .....	27
Table 18. Occupied Bandwidth 802.11g Mode, Test Results .....	27
Table 19. Occupied Bandwidth 802.11n Mode, Test Results .....	27
Table 20. Output Power Requirements from §15.247 .....	37
Table 21. RF Output Power, 802.11b, Test Results .....	38
Table 22. RF Output Power, 802.11g, Test Results .....	38
Table 23. RF Output Power, 802.11n, Test Results .....	38
Table 24. Restricted Bands of Operation .....	47
Table 25. Radiated Emissions Limits Calculated from FCC Part 15, § 15.209 (a) .....	48
Table 26. Radiated Harmonic Emissions, 802.11b, Low Channel, Test Results .....	49
Table 27. Radiated Harmonic Emissions, 802.11b, Mid Channel, Test Results .....	49
Table 28. Radiated Harmonic Emissions, 802.11b, High Channel, Test Results .....	49
Table 29. Radiated Harmonic Emissions, 802.11g, Low Channel, Test Results .....	50
Table 30. Radiated Harmonic Emissions, 802.11g, Mid Channel, Test Results .....	50
Table 31. Radiated Harmonic Emissions, 802.11g, High Channel, Test Results .....	50
Table 32. Radiated Harmonic Emissions, 802.11n, Low Channel, Test Results .....	51
Table 33. Radiated Harmonic Emissions, 802.11n, Mid Channel, Test Results .....	51
Table 34. Radiated Harmonic Emissions, 802.11n, High Channel, Test Results .....	51
Table 35. Spurious Emission Limits for Receivers .....	68
Table 36. Spectral Density, 802.11b, Test Results .....	84
Table 37. Spectral Density, 802.11g, Test Results .....	84
Table 38. Spectral Density, 802.11n, Test Results .....	84
Table 39. Test Equipment List .....	91

## List of Plots

Plot 1. Conducted Emissions, Phase Line Plot.....	12
Plot 2. Conducted Emissions, Neutral Line Plot.....	13
Plot 3. Radiated Emissions, 30 MHz – 1 GHz, FCC Limits.....	16
Plot 4. Radiated Emissions, 1 GHz – 2 GHz, FCC Limits.....	17
Plot 5. Radiated Emissions, ICES-003 Limits.....	18
Plot 6. Conducted Emissions, Phase Line Plot.....	23
Plot 7. Conducted Emissions, Neutral Line Plot.....	24
Plot 8. Occupied Bandwidth Low Channel, 802.11b (99%).....	28
Plot 9. Occupied Bandwidth Low Channel, 802.11b (FCC).....	28
Plot 10. Occupied Bandwidth Mid Channel, 802.11b (99%).....	29
Plot 11. Occupied Bandwidth Mid Channel, 802.11b (FCC).....	29
Plot 12. Occupied Bandwidth High Channel, 802.11b (99%).....	30
Plot 13. Occupied Bandwidth High Channel, 802.11b (FCC).....	30
Plot 14. Occupied Bandwidth Low Channel, 802.11g (99%).....	31
Plot 15. Occupied Bandwidth Low Channel, 802.11g (FCC).....	31
Plot 16. Occupied Bandwidth Mid Channel, 802.11g (99%).....	32
Plot 17. Occupied Bandwidth Mid Channel, 802.11g (FCC).....	32
Plot 18. Occupied Bandwidth High Channel, 802.11g (99%).....	33
Plot 19. Occupied Bandwidth High Channel, 802.11g (FCC).....	33
Plot 20. Occupied Bandwidth Low Channel, 802.11n (99%).....	34
Plot 21. Occupied Bandwidth Low Channel, 802.11n (FCC).....	34
Plot 22. Occupied Bandwidth Mid Channel, 802.11n (99%).....	35
Plot 23. Occupied Bandwidth Mid Channel, 802.11n (FCC).....	35
Plot 24. Occupied Bandwidth High Channel, 802.11n (99%).....	36
Plot 25. Occupied Bandwidth High Channel, 802.11n (FCC).....	36
Plot 26. Peak Power Output, 802.11b, Low Channel.....	39
Plot 27. Peak Power Output, 802.11b, Mid Channel.....	39
Plot 28. Peak Power Output, 802.11b, High Channel.....	40
Plot 29. Peak Power Output, 802.11g, Low Channel.....	40
Plot 30. Peak Power Output, 802.11g, Mid Channel.....	41
Plot 31. Peak Power Output, 802.11g, High Channel.....	41
Plot 32. Peak Power Output, Channel 2, 802.11g.....	42
Plot 33. Peak Power Output, Channel 10, 802.11g.....	42
Plot 34. Peak Power Output, 802.11n, Low Channel.....	43
Plot 35. Peak Power Output, 802.11n, Mid Channel.....	43
Plot 36. Peak Power Output, 802.11n, High Channel.....	44
Plot 37. Peak Power Output, 802.11n, Channel 2.....	44
Plot 38. Peak Power Output, 802.11n, Channel 10.....	45
Plot 39. Radiated Spurious Emissions, 802.11b, Low Channel.....	52
Plot 40. Radiated Spurious Emissions, 802.11b, Mid Channel.....	52
Plot 41. Radiated Spurious Emissions, 802.11b, High Channel.....	53
Plot 42. Radiated Spurious Emissions, 802.11g, Low Channel.....	53
Plot 43. Radiated Spurious Emissions, 802.11g, Mid Channel.....	54
Plot 44. Radiated Spurious Emissions, 802.11g, High Channel.....	54
Plot 45. Radiated Spurious Emissions, 802.11n, Low Channel.....	55
Plot 46. Radiated Spurious Emissions, 802.11n, Mid Channel.....	55
Plot 47. Radiated Spurious Emissions, 802.11n, High Channel.....	56
Plot 48. Radiated Band Edge, 802.11b, Channel 1 (Average).....	57
Plot 49. Radiated Band Edge, 802.11b, Channel 1 (Peak).....	57
Plot 50. Radiated Band Edge, 802.11b, Channel 11 (Average).....	58
Plot 51. Radiated Band Edge, 802.11b, Channel 11 (Peak).....	58
Plot 52. Radiated Band Edge, 802.11g, Channel 1 (Average).....	59

Plot 53. Radiated Band Edge, 802.11g, Channel 1(Peak) .....	59
Plot 54. Radiated Band Edge, 802.11g, Channel 2 (Average).....	60
Plot 55. Radiated Band Edge, 802.11g, Channel 2 (Peak) .....	60
Plot 56. Radiated Band Edge, 802.11g, Channel 10 (Average).....	61
Plot 57. Radiated Band Edge, 802.11g, Channel 10 (Peak) .....	61
Plot 58. Radiated Band Edge, 802.11g, Channel 11 (Average).....	62
Plot 59. Radiated Band Edge, 802.11g, Channel 11 (Peak) .....	62
Plot 60. Radiated Band Edge, 802.11n, Channel 1 (Average).....	63
Plot 61. Radiated Band Edge, 802.11n, Channel 1 (Peak) .....	63
Plot 62. Radiated Band Edge, 802.11n, Channel 2 (Average).....	64
Plot 63. Radiated Band Edge, 802.11n, Channel 2 (Peak) .....	64
Plot 64. Radiated Band Edge, 802.11n, Channel 10 (Average).....	65
Plot 65. Radiated Band Edge, 802.11n, Channel 10 (Peak) .....	65
Plot 66. Radiated Band Edge, 802.11n, Channel 11 (Average).....	66
Plot 67. Radiated Band Edge, 802.11n, Channel 11 (Peak) .....	66
Plot 68. Receiver Spurious Emission, 30 MHz – 1 GHz, Horizontal.....	69
Plot 69. Receiver Spurious Emission, 1 GHz – 10 GHz, Vertical.....	69
Plot 70. Conducted Spurious, Low Channel, 802.11b (30 MHz - 1 GHz) .....	71
Plot 71. Conducted Spurious, Low Channel, 802.11b (1 GHz - 26 GHz).....	71
Plot 72. Conducted Spurious, Mid Channel, 802.11b (30 MHz - 1 GHz).....	72
Plot 73. Conducted Spurious, Mid Channel, 802.11b (1 GHz - 26 GHz) .....	72
Plot 74. Conducted Spurious, High Channel, 802.11b (30 MHz - 1 GHz) .....	73
Plot 75. Conducted Spurious, High Channel, 802.11b (1 GHz - 26 GHz).....	73
Plot 76. Conducted Spurious, Low Channel, 802.11g (30 MHz - 1 GHz) .....	74
Plot 77. Conducted Spurious, Low Channel, 802.11g (1 GHz - 26 GHz).....	74
Plot 78. Conducted Spurious, Mid Channel, 802.11g (30 MHz - 1 GHz).....	75
Plot 79. Conducted Spurious, Mid Channel, 802.11g (1 GHz - 26 GHz) .....	75
Plot 80. Conducted Spurious, High Channel, 802.11g (30 MHz - 1 GHz) .....	76
Plot 81. Conducted Spurious, High Channel, 802.11g (1 GHz - 26 GHz).....	76
Plot 82. Conducted Spurious, Low Channel, 802.11n (30 MHz - 1 GHz) .....	77
Plot 83. Conducted Spurious, Low Channel, 802.11n (1 GHz - 26 GHz).....	77
Plot 84. Conducted Spurious, Mid Channel, 802.11n (30 MHz - 1 GHz).....	78
Plot 85. Conducted Spurious, Mid Channel, 802.11n (1 GHz - 26 GHz) .....	78
Plot 86. Conducted Spurious, High Channel, 802.11n (30 MHz - 1 GHz) .....	79
Plot 87. Conducted Spurious, High Channel, 802.11n (1 GHz - 26 GHz).....	79
Plot 88. Conducted Band Edge, Low Channel, 802.11b 20MHz .....	80
Plot 89. Conducted Band Edge, High Channel, 802.11b 20MHz .....	80
Plot 90. Conducted Band Edge, Low Channel, 802.11g 20MHz .....	81
Plot 91. Conducted Band Edge, High Channel, 802.11g 20MHz .....	81
Plot 92. Conducted Band Edge, Low Channel, 802.11n 20MHz .....	82
Plot 93. Conducted Band Edge, High Channel, 802.11n 20MHz .....	82
Plot 94. Peak Spectral Density, Low Channel, 802.11b .....	85
Plot 95. Peak Spectral Density, Mid Channel, 802.11b.....	85
Plot 96. Peak Spectral Density, High Channel, 802.11b .....	86
Plot 97. Peak Spectral Density, Low Channel, 802.11g .....	86
Plot 98. Peak Spectral Density, Mid Channel, 802.11g.....	87
Plot 99. Peak Spectral Density, High Channel, 802.11g .....	87
Plot 100. Peak Spectral Density, Low Channel, 802.11n.....	88
Plot 101. Peak Spectral Density, Mid Channel, 802.11n.....	88
Plot 102. Peak Spectral Density, High Channel, 802.11n .....	89



## List of Figures

Figure 1. Block Diagram of Test Configuration.....	7
Figure 2. Block Diagram, Occupied Bandwidth Test Setup.....	26
Figure 3. Peak Power Output Test Setup.....	37
Figure 4. Block Diagram, Conducted Receiver Spurious Emissions, Test Setup .....	68
Figure 5. Block Diagram, Conducted Spurious Emissions, Test Setup.....	70
Figure 6. Block Diagram, Peak Power Spectral Density, Test Setup.....	83

## List of Photographs

Photograph 1. Ubiquiti Networks E2 .....	6
Photograph 2. Conducted Emissions, Test Setup .....	14
Photograph 3. Conducted Emissions, Test Setup, Side View .....	14
Photograph 4. Radiated Emissions, Test Setup .....	19
Photograph 5. Conducted Emissions, 15.207, Test Setup .....	25
Photograph 6. Conducted Emissions, 15.207, Test Setup, Side View.....	25
Photograph 7. Radiated Spurious Emissions, Test Setup.....	67

## List of Terms and Abbreviations

AC	Alternating Current
ACF	Antenna Correction Factor
Cal	Calibration
<i>d</i>	Measurement Distance
dB	Decibels
dB $\mu$ A	Decibels above one <b>microamp</b>
dB $\mu$ V	Decibels above one <b>microvolt</b>
dB $\mu$ A/m	Decibels above one <b>microamp per meter</b>
dB $\mu$ V/m	Decibels above one <b>microvolt per meter</b>
DC	Direct Current
E	Electric Field
DSL	Digital Subscriber Line
ESD	Electrostatic Discharge
EUT	Equipment Under Test
<i>f</i>	Frequency
FCC	Federal Communications Commission
GRP	Ground Reference Plane
H	Magnetic Field
HCP	Horizontal Coupling Plane
Hz	Hertz
IEC	International Electrotechnical Commission
kHz	kilohertz
kPa	kilopascal
kV	kilovolt
LISN	Line Impedance Stabilization Network
MHz	Megahertz
$\mu$ H	microhenry
$\mu$	microfarad
$\mu$ s	microseconds
NEBS	Network Equipment-Building System
PRF	Pulse Repetition Frequency
RF	Radio Frequency
RMS	Root-Mean-Square
TWT	Traveling Wave Tube
V/m	Volts per meter
VCP	Vertical Coupling Plane

# I. Executive Summary

## A. Purpose of Test

An EMC evaluation was performed to determine compliance of the Ubiquiti Networks E2, with the requirements of Part 15, §15.247. All references are to the most current version of Title 47 of the Code of Federal Regulations in effect. In accordance with §2.1033, the following data is presented in support of the Certification of the E2. Ubiquiti Networks should retain a copy of this document which should be kept on file for at least two years after the manufacturing of the E2, has been **permanently** discontinued.

## B. Executive Summary

The following tests were conducted on a sample of the equipment for the purpose of demonstrating compliance with Part 15, §15.247, in accordance with Ubiquiti Networks, purchase order number US090038. All tests were conducted using measurement procedure ANSI C63.4-2003.

FCC Reference	IC Reference	Description	Compliance
47 CFR Part 15.247:2005	RSS-210 Issue 7: 2007		
47 CFR Part 15.107 (a)	ICES-003 Issue 4 February 2004	Conducted Emission Limits for a Class A Digital Device	Compliant
47 CFR Part 15.109 (a)	ICES-003 Issue 4 February 2004	Radiated Emission Limits for a Class A Digital Device	Compliant
Title 47 of the CFR, Part 15 §15.203	N/A	Antenna Requirement	Compliant
Title 47 of the CFR, Part 15 §15.207(a)	RSS-210(7.2.2)	Conducted Emission Voltage	Compliant
Title 47 of the CFR, Part 15 §15.247(a)(1)	RSS-210(A8.1)	Occupied Bandwidth	Compliant
Title 47 of the CFR, Part 15 §15.247(b)	RSS-210(A8.4)	RF Output Power	Compliant
Title 47 of the CFR, Part 15 §15.209, §15.247(d)	RSS-210(A8.5)	Radiated Spurious Emissions	Compliant
Title 47 of the CFR, Part 15 §15.205	RSS-210(A8.5)	Emissions at Restricted Band	Compliant
Title 47 of the CFR, Part 15 §15.209, §15.247(d)	RSS-210(A8.5)	Conducted Spurious Emissions	Compliant
Title 47 of the CFR, Part 15; §15.247(e)	RSS-210(A8.3)	Power Spectral Density	Compliant
Title 47 of the CFR, Part 15 §15.247(i)	RSS-Gen(5.5)	Maximum Permissible Exposure	Compliant
N/A	RSS-Gen(4.8)	Receiver Spurious Emissions	Compliant

**Table 1. Executive Summary of EMC Part 15.247 Compliance Testing**

## II. Equipment Configuration

## A. Overview

MET Laboratories, Inc. was contracted by Ubiquiti Networks to perform testing on the E2, under Ubiquiti Networks's purchase order number US090038.

This document describes the test setups, test methods, required test equipment, and the test limit criteria used to perform compliance testing of the Ubiquiti Networks, E2.

The results obtained relate only to the item(s) tested.

<b>Model(s) Tested:</b>	E2	
<b>Model(s) Covered:</b>	E2	
<b>EUT Specifications:</b>	Primary Power: -48 VDC	
	FCC ID: SWX-E2 IC: 6545A-E2	
	Type of Modulations:	OFDM
	Equipment Code:	DTS
	Peak RF Output Power:	802.11b: 26.57 dBm
		802.11g: 26.67 dBm
802.11n: 26.19 dBm		
EUT Frequency Ranges:	2412 – 2462 MHz	
<b>Analysis:</b>	The results obtained relate only to the item(s) tested.	
<b>Environmental Test Conditions:</b>	Temperature: 15-35° C	
	Relative Humidity: 30-60%	
	Barometric Pressure: 860-1060 mbar	
<b>Evaluated by:</b>	Anderson Soungpanya	
<b>Report Date(s):</b>	June 8, 2010	

**Table 2. EUT Summary Table**

## B. References

<b>CFR 47, Part 15, Subpart C</b>	Federal Communication Commission, Code of Federal Regulations, Title 47, Part 15: General Rules and Regulations, Allocation, Assignment, and Use of Radio Frequencies
<b>RSS-210, Issue 7, June 2007</b>	Low-power Licence-exempt Radiocommunications Devices (All Frequency Bands): Category I Equipment
<b>CFR 47, Part 15, Subpart B</b>	Electromagnetic Compatibility: Criteria for Radio Frequency Devices
<b>ICES-003, Issue 4 February 2004</b>	Electromagnetic Compatibility: Criteria for Radio Frequency Devices
<b>ANSI C63.4:2003</b>	Methods and Measurements of Radio-Noise Emissions from Low-Voltage Electrical And Electronic Equipment in the Range of 9 kHz to 40 GHz
<b>ANSI/NCSL Z540-1-1994</b>	Calibration Laboratories and Measuring and Test Equipment - General Requirements
<b>ANSI/ISO/IEC 17025:2000</b>	General Requirements for the Competence of Testing and Calibration Laboratories
<b>ANSI C63.10-2009</b>	American National Standard for Testing Unlicensed Wireless Devices

**Table 3. References**

## C. Test Site

All testing was performed at MET Laboratories, Inc., 3162 Belick St., Santa Clara, CA 95054. All equipment used in making physical determinations is accurate and bears recent traceability to the National Institute of Standards and Technology.

Radiated Emissions measurements were performed in a 10 meter semi-anechoic chamber (equivalent to an Open Area Test Site). In accordance with §2.948(a)(3), a complete site description is contained at MET Laboratories.

## D. Description of Test Sample

The Ubiquiti Networks E2, Equipment Under Test (EUT), is a E2-2400 MHz 802. 11b/g/n Radio.



**Photograph 1. Ubiquiti Networks E2**



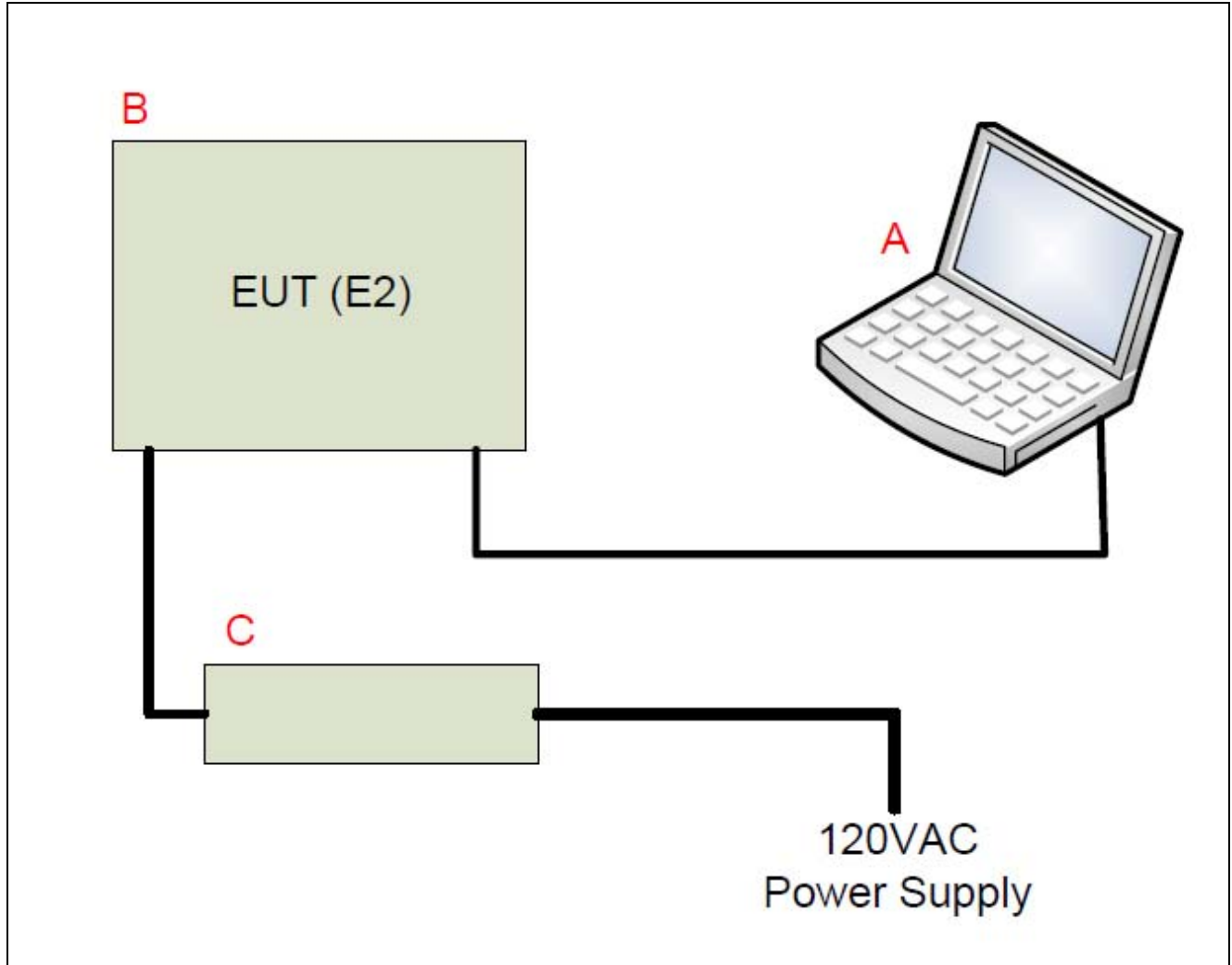


Figure 1. Block Diagram of Test Configuration

## E. Equipment Configuration

The EUT was set up as outlined in Figure 1, Block Diagram of Test Setup. All cards, racks, etc., incorporated as part of the EUT is included in the following list.

Ref. ID	Name / Description	Model Number	Part Number	Serial Number
A	2400MHz Radio	E2	NA	D6954

**Table 4. Equipment Configuration**

## F. Support Equipment

Support equipment necessary for the operation and testing of the EUT is included in the following list.

Ref. ID	Name / Description	Manufacturer	Model Number
B	AC/DC Power Supply	GME	GFP121U-050200B-1
C	Laptop	Dell	Vostro 1000

**Table 5. Support Equipment**

## G. Ports and Cabling Information

Ref. ID	Port name on EUT	Cable Description or reason for no cable	Qty.	Length (m)	Shielded (Y/N)	Termination Box ID & Port Name
<b>E2</b>						
1	A, Ethernet	Ethernet	1	2	Y	C
2	A, Power Input	2 Conductor DC Cable	1	1	N	B, 120VAC 60Hz

**Table 6. Ports and Cabling Information**

## **H. Mode of Operation**

Use Atheros Radio Test Software.

## **I. Method of Monitoring EUT Operation**

Ping Times out and doesn't return. Unit locks up requires power down is a fail.

## **J. Modifications**

- a) **Modifications to EUT**  
No modifications were made to the EUT.
- b) **Modifications to Test Standard**  
No modifications were made to the test standard.

## **K. Disposition of EUT**

The test sample including all support equipment submitted to the Electro-Magnetic Compatibility Lab for testing was returned to Ubiquiti Networks upon completion of testing.

# **III. Electromagnetic Compatibility Criteria for Unintentional Radiators**

## Electromagnetic Compatibility Criteria

### § 15.107 Conducted Emissions Limits

**Test Requirement(s):** **15.107 (a)** Except for Class A digital devices, for equipment that is designed to be connected to the public utility (AC) power line, the radio frequency voltage that is conducted back onto the AC power line on any frequency or frequencies within the band 150 kHz to 30 MHz shall not exceed the limits in Table 7. Compliance with this provision shall be based on the measurement of the radio frequency voltage between each power line and ground at the power terminals.

**15.107 (b)** For a Class A digital device that is designed to be connected to the public utility (AC) power line, the radio frequency voltage that is conducted back onto the AC power line on any frequency or frequencies within the band 150 kHz to 30 MHz shall not exceed the limits in Table 7. Compliance with this provision shall be based on the measurement of the radio frequency voltage between each power line and ground at the power terminals. The lower limit applies at the band edges.

**15.207(a)**, Except as shown in paragraphs (b) and (c) of this section\*, charging, AC adapters or battery eliminators the radio frequency voltage that is conducted back onto the AC power line on any frequency or frequencies, within the band 150 kHz to 30 MHz, shall not exceed the limits in the Table 7, as measured using a 50  $\mu$ H/50 ohms line impedance stabilization network (LISN). Compliance with the provisions of this paragraph shall be based on the measurement of the radio frequency voltage between each power line and ground at the power terminal. The lower limit applies at the boundary between the frequencies ranges.

Frequency range (MHz)	Class A Conducted Limits (dB $\mu$ V)		*Class B Conducted Limits (dB $\mu$ V)	
	Quasi-Peak	Average	Quasi-Peak	Average
* 0.15- 0.45	79	66	66 - 56	56 - 46
0.45 - 0.5	79	66	56	46
0.5 - 30	73	60	60	50

Note 1 — The lower limit shall apply at the transition frequencies.  
 Note 2 — The limit decreases linearly with the logarithm if the frequency in the range 0.15 MHz to 0.5 MHz.  
 \* -- Limits per Subsection 15.207(a).

**Table 7. Conducted Limits for Radio Frequency Devices calculated from FCC Part 15 Subsections 15.107(a) (b) and 15.207(a)**

**Test Results:** The EUT was compliant with the Class A requirement(s) of this section. Measured emissions were below applicable limits.

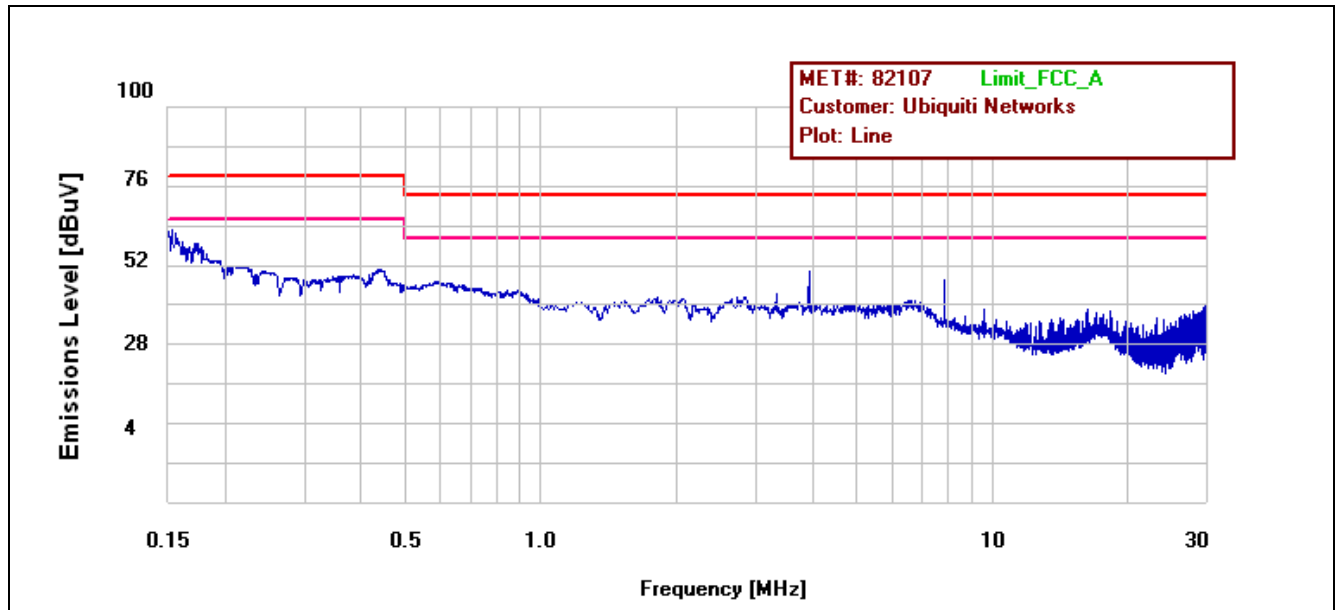
**Test Engineer(s):** Anderson Soungpanya

**Test Date(s):** 05/27/10

### Conducted Emissions - Voltage, AC Power, Phase Line

Freq (MHz)	QP Amplitude	QP Limit	Delta	Pass	Average Amplitude	Average Limit	Delta	Pass
.154	54.34	79	-24.66	Pass	42.24	66	-23.76	Pass
.441	48.08	79	-30.92	Pass	37.35	66	-28.65	Pass
3.93	43.23	73	-29.77	Pass	24.99	60	-35.01	Pass

Table 8. Conducted Emissions - Voltage, AC Power, Phase Line, Test Results

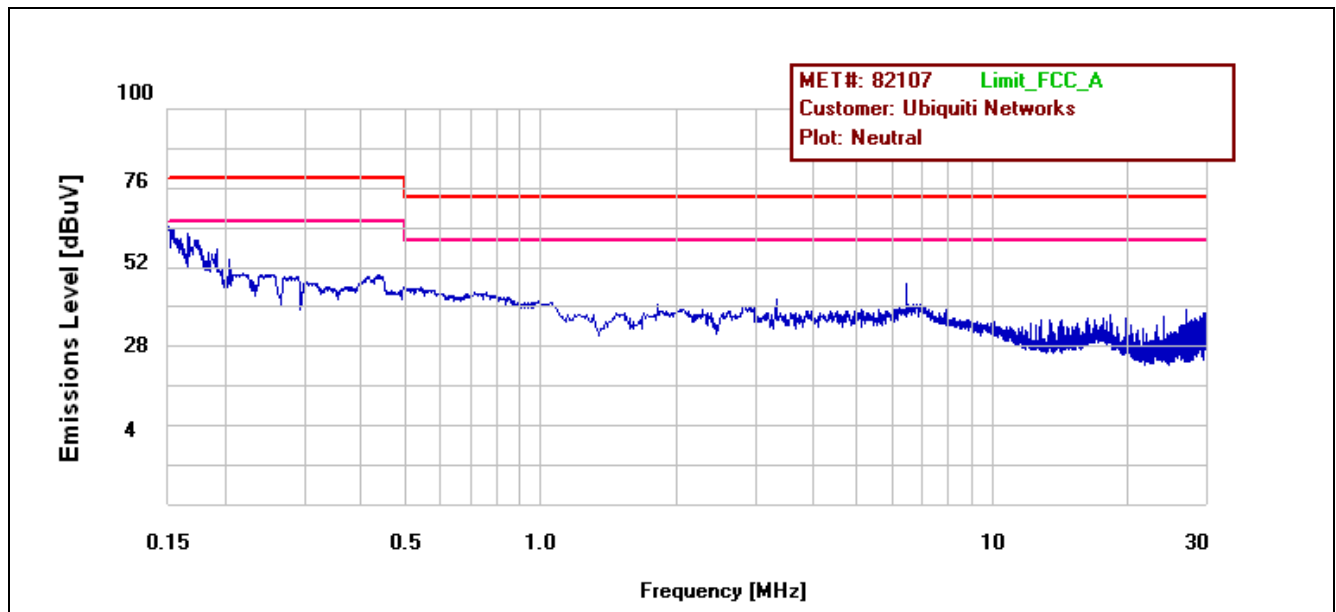


Plot 1. Conducted Emissions, Phase Line Plot

### Conducted Emissions - Voltage, AC Power, Neutral Line

Freq (MHz)	QP Amplitude	QP Limit	Delta	Pass	Average Amplitude	Average Limit	Delta	Pass
.157	53.31	79	-25.69	Pass	41.94	66	-24.06	Pass
.443	45.51	79	-33.49	Pass	33.56	66	-32.44	Pass
6.46	40.72	73	-32.28	Pass	24.63	60	-35.37	Pass

Table 9. Conducted Emissions - Voltage, AC Power, Neutral Line, Test Results



Plot 2. Conducted Emissions, Neutral Line Plot

## Conducted Emission Limits Test Setup



**Photograph 2. Conducted Emissions, Test Setup**



**Photograph 3. Conducted Emissions, Test Setup, Side View**



## Electromagnetic Compatibility Criteria

### § 15.109 Radiated Emissions Limits

**Test Requirement(s):** **15.109 (a)** Except for Class A digital devices, the field strength of radiated emissions from unintentional radiators at a distance of 3 meters shall not exceed the Class B limits expressed in Table 10.

**15.109 (b)** The field strength of radiated emissions from a Class A digital device, as determined at a distance of 10 meters, shall not exceed the Class A limits expressed in Table 10.

Frequency (MHz)	Field Strength (dB $\mu$ V/m)	
	§15.109 (b), Class A Limit (dB $\mu$ V) @ 10m	§15.109 (a), Class B Limit (dB $\mu$ V) @ 3m
30 - 88	39.00	40.00
88 - 216	43.50	43.50
216 - 960	46.40	46.00
Above 960	49.50	54.00

**Table 10. Radiated Emissions Limits calculated from FCC Part 15, §15.109 (a) (b)**

**Test Procedures:** The EUT was placed on a non-metallic table, 80 cm above the ground plane inside a semi-anechoic chamber. The method of testing and test conditions of ANSI C63.4 were used. An antenna was located 3 m from the EUT on an adjustable mast. A pre-scan was first performed in order to find prominent radiated emissions. For final emissions measurements at each frequency of interest, the EUT was rotated and the antenna height was varied between 1 m and 4 m in order to maximize the emission. Measurements in both horizontal and vertical polarities were made and the data was recorded. Unless otherwise specified, measurements were made using a quasi-peak detector with a 120 kHz bandwidth.

**Test Results:** The EUT was compliant with the Class A requirement(s) of this section. Measured emissions were below applicable limits.

**Test Engineer(s):** Kenshi Chung

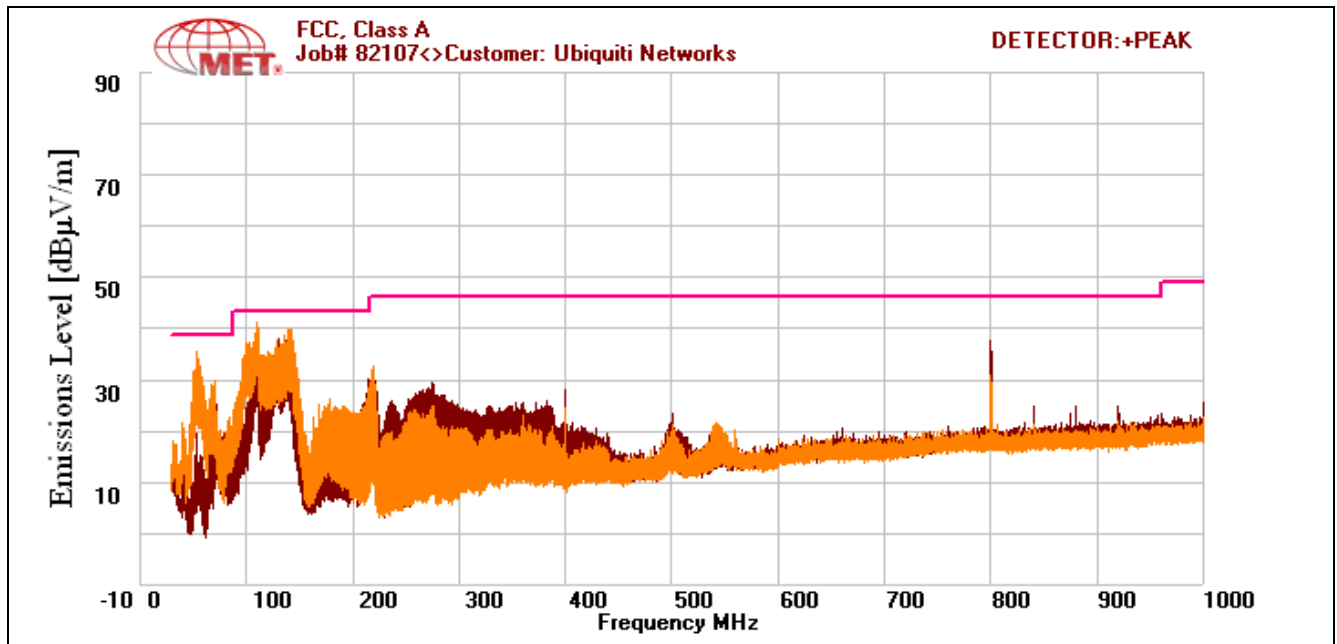
**Test Date(s):** 01/26/10

### Radiated Emissions Limits Test Results, Class A

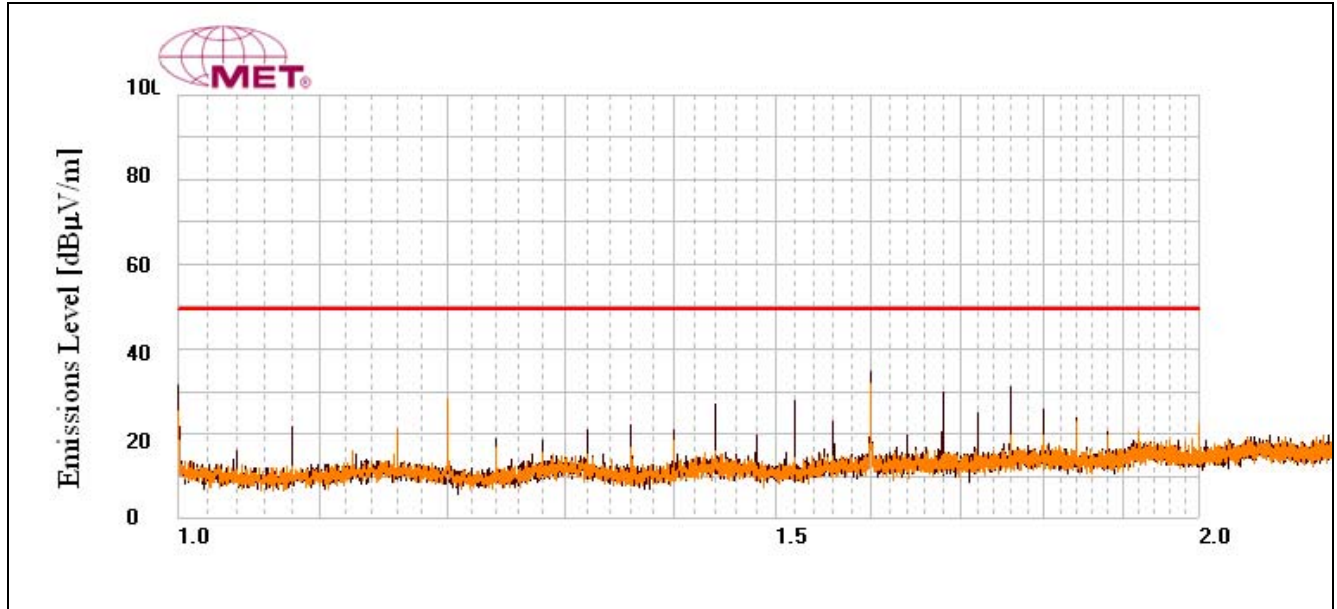
Frequency (MHz)	Antenna Polarity	EUT Azimuth (Degrees)	Antenna Height (cm)	Uncorrected Amplitude (dBμV)	ACF (dB/m)	Pre Amp Gain (dB)	CBL (dB)	DCF (dB)	Corrected Amplitude (dBμV/m)	Limit (dBμV/m)	Margin (dB)
53.633	V	254	100	29.23	7.2	0	1.891	-10.46	27.861	39	-11.139
110.16	V	160	100	33.91	12.916	0	2.958	-10.46	39.324	43.5	-4.176
140.46	V	73	100	34.61	12.363	0	3.279	-10.46	39.792	43.5	-3.708
109.09	H	248	260	32.96	12.309	0	2.946	-10.46	37.755	43.5	-5.745
129.28	H	288	216	32.23	12.629	0	3.16	-10.46	37.559	43.5	-5.941
138.36	H	285	211	33.58	12.098	0	3.257	-10.46	38.475	43.5	-5.025
800.01	H	312	100	24.25	20.9	0	6.23	-10.46	40.92	46.4	-5.48
1000	H	269	100	83.73	27.216	77.23	7.5	-10.46	30.756	49.5	-18.744
1600	H	79	100	86.43	28.832	75.758	9.31	-10.46	38.354	49.5	-11.146
1200	V	225	100	78.97	27.647	76.69	8.112	-10.46	27.579	49.5	-21.921

Table 11. Radiated Emissions Limits, Test Results, 30MHz – 2GHz FCC Limits

Note: The EUT was tested at 3 m.



Plot 3. Radiated Emissions, 30 MHz – 1 GHz, FCC Limits



Plot 4. Radiated Emissions, 1 GHz – 2 GHz, FCC Limits

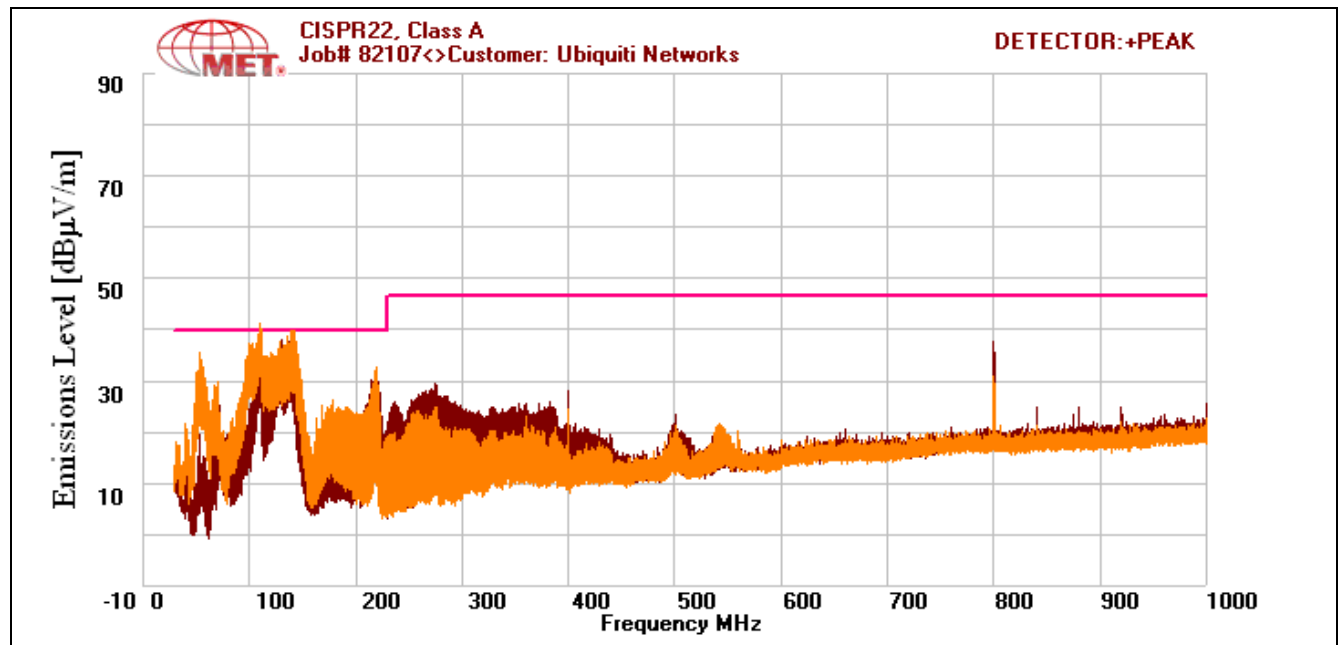
### Radiated Emissions Limits Test Results, Class A

Frequency (MHz)	Antenna Polarity	EUT Azimuth (Degrees)	Antenna Height (cm)	Uncorrected Amplitude (dB $\mu$ V)	ACF (dB/m)	Pre Amp Gain (dB)	CBL (dB)	DCF (dB)	Corrected Amplitude (dB $\mu$ V/m)	Limit (dB $\mu$ V/m)	Margin (dB)
53.633	V	254	100	29.23	7.2	0	1.891	-10.46	27.861	40	-12.139
110.16	V	160	100	33.91	12.916	0	2.958	-10.46	39.324	40	-0.676*
140.46	V	73	100	34.61	12.363	0	3.279	-10.46	39.792	40	-0.207*
109.09	H	248	260	32.96	12.309	0	2.946	-10.46	37.755	40	-2.245*
129.28	H	288	216	32.23	12.629	0	3.16	-10.46	37.559	40	-2.441*
138.36	H	285	211	33.58	12.098	0	3.257	-10.46	38.475	40	-1.525*
800.01	H	312	100	24.25	20.9	0	6.23	-10.46	40.92	47	-6.08

**Table 12. Radiated Emissions Limits, Test Results, ICES-003 Limits**

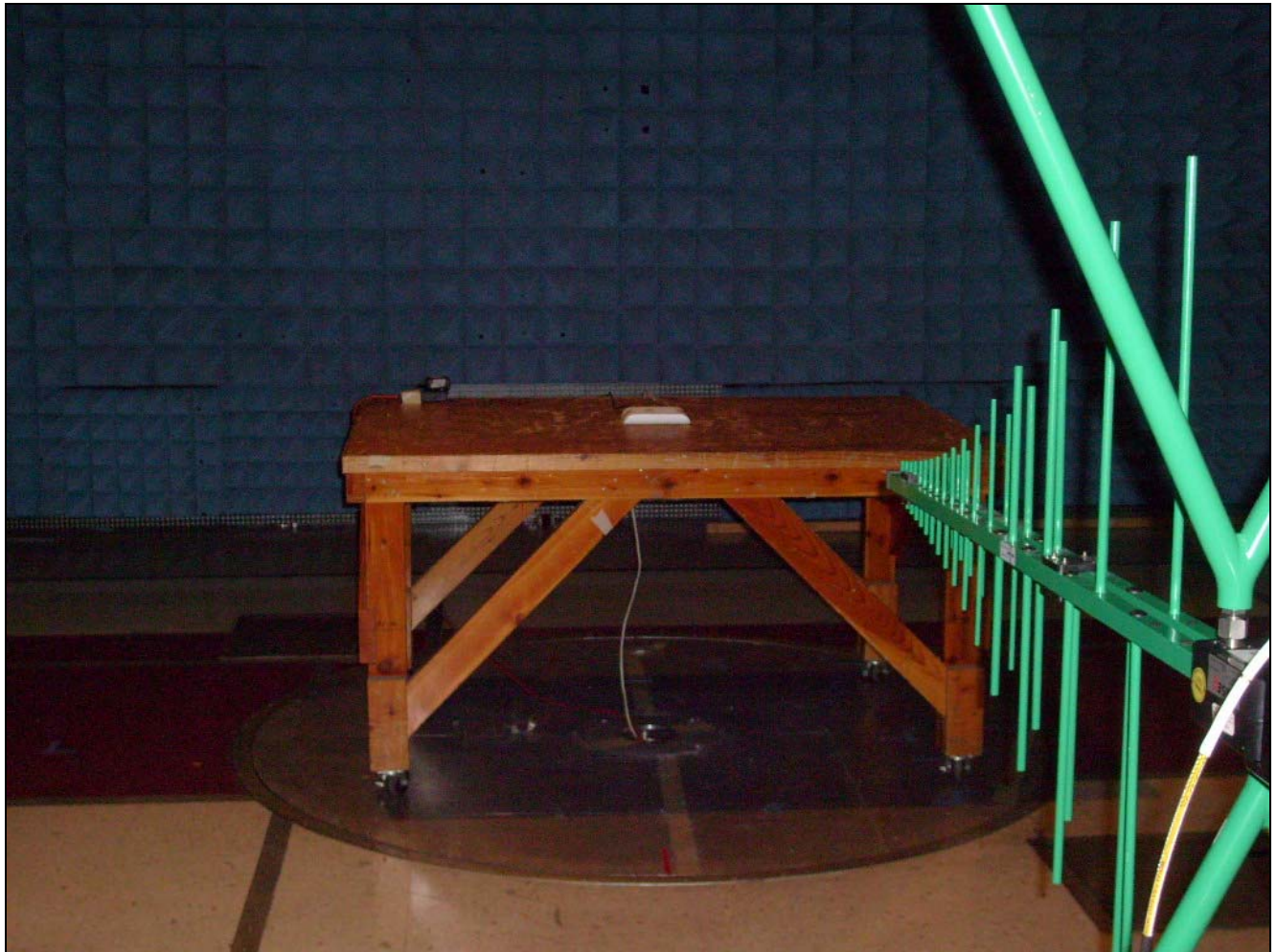
Note 1: \* - At this frequency, the measured electric-field strength exhibits a margin of compliance that is less than 3 dB below the specification limit. We recommend that every emission measured, have at least a 3 dB margin to allow for deviations in the emission characteristics that may occur during the production process.

Note 2: The EUT was tested at 3 m.



**Plot 5. Radiated Emissions, ICES-003 Limits**

## Radiated Emission Limits Test Setup



**Photograph 4. Radiated Emissions, Test Setup**

## **IV. Electromagnetic Compatibility Criteria for Intentional Radiators**

## Electromagnetic Compatibility Criteria for Intentional Radiators

### § 15.203 Antenna Requirement

**Test Requirement:** § 15.203: An intentional radiator shall be designed to ensure that no antenna other than that furnished by the responsible party shall be used with the device. The use of a permanently attached antenna or of an antenna that uses a unique coupling to the intentional radiator shall be considered sufficient to comply with the provisions of this section. The manufacturer may design the unit so that a broken antenna can be replaced by the user, but the use of a standard antenna jack or electrical connector is prohibited.

The structure and application of the EUT were analyzed to determine compliance with Section 15.203 of the Rules. Section 15.203 states that the subject device must meet at least one of the following criteria:

- a.) Antenna must be permanently attached to the unit.
- b.) Antenna must use a unique type of connector to attach to the EUT.
- c.) Unit must be professionally installed. Installer shall be responsible for verifying that the correct antenna is employed with the unit.

**Results:** The EUT as tested is compliant the criteria of §15.203(c). The EUT contains an integral antenna.

**Test Engineer(s):** Anderson Soungpanya

**Test Date(s):** 01/22/10

Gain	Type	Model	Manufacturer
0dBi	Integral	NA	Ubiquiti

**Table 13. Antenna List**

## Electromagnetic Compatibility Criteria for Intentional Radiators

### § 15.207 Conducted Emissions Limits

**Test Requirement(s):** § 15.207 (a): For an intentional radiator that is designed to be connected to the public utility (AC) power line, the radio frequency voltage that is conducted back onto the AC power line on any frequency or frequencies, within the band 150 kHz to 30MHz, shall not exceed the limits in the following table, as measured using a 50  $\mu$ H/50  $\Omega$  line impedance stabilization network (LISN). Compliance with the provisions of this paragraph shall be based on the measurement of the radio frequency voltage between each power line and ground at the power terminal. The lower limit applies at the boundary between the frequency ranges.

Frequency range (MHz)	§ 15.207(a), Conducted Limit (dB $\mu$ V)	
	Quasi-Peak	Average
* 0.15- 0.45	66 - 56	56 - 46
0.45 - 0.5	56	46
0.5 - 30	60	50

**Table 14. Conducted Limits for Intentional Radiators from FCC Part 15 § 15.207(a)**

**Test Procedure:** The EUT was placed on a 0.8 m-high wooden table inside a screen room. The EUT was situated such that the back of the EUT was 0.4 m from one wall of the vertical ground plane, and the remaining sides of the EUT were no closer than 0.8 m from any other conductive surface. The EUT was powered from a 50  $\Omega$ /50  $\mu$ H Line Impedance Stabilization Network (LISN). The EMC receiver scanned the frequency range from 150 kHz to 30 MHz. Conducted Emissions measurements were made in accordance with *ANSI C63.4-2003 "Methods and Measurements of Radio-Noise Emissions from Low-Voltage Electrical and Electronic Equipment in the Range of 9kHz to 40 GHz"*. The measurements were performed over the frequency range of 0.15 MHz to 30 MHz using a 50  $\Omega$ /50  $\mu$ H LISN as the input transducer to an EMC/field intensity meter. For the purpose of this testing, the transmitter was turned on. Scans were performed with the transmitter on.

**Test Results:** The EUT was compliant with this requirement. Measured emissions were below applicable limits.

**Test Engineer(s):** Anderson Soungpanya

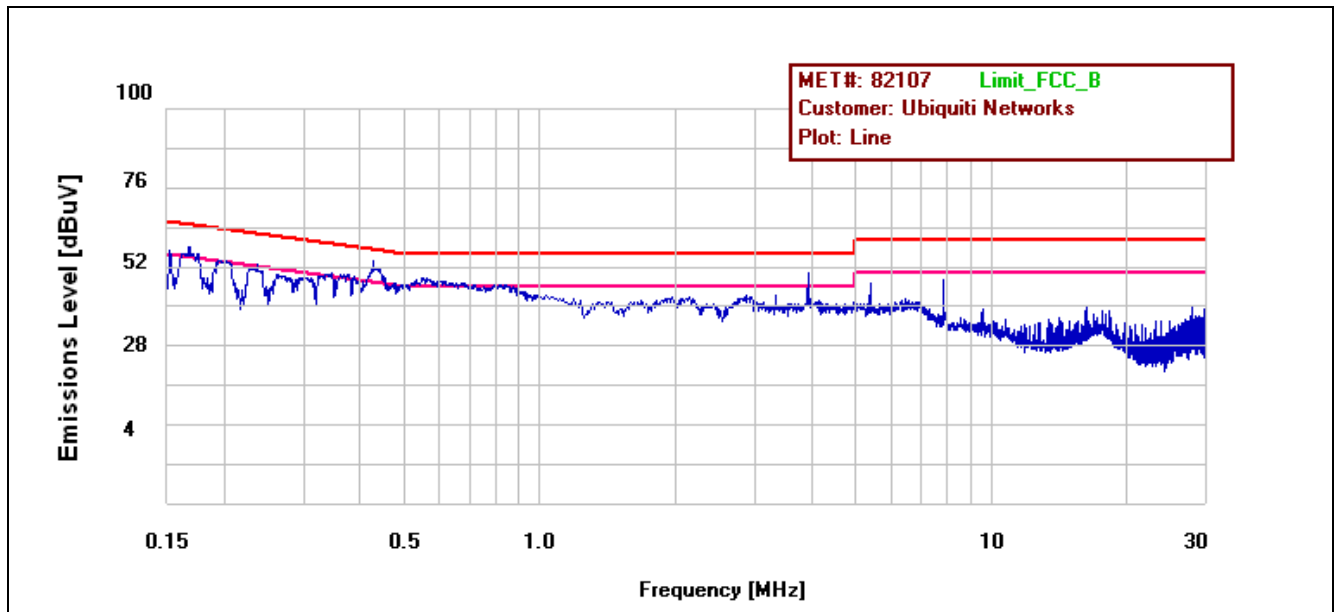
**Test Date(s):** 05/27/10



### 15.207 Conducted Emissions Test Results

Freq (MHz)	QP Amplitude	QP Limit	Delta	Pass	Average Amplitude	Average Limit	Delta	Pass
.165	53.89	65.211	-11.321	Pass	42.62	55.211	-12.591	Pass
.436	48.57	57.162	-8.592	Pass	38.06	47.162	-9.102	Pass
.590	43.86	56	-12.14	Pass	28.19	46	-17.81	Pass
3.93	42.81	56	-13.19	Pass	25.82	46	-20.18	Pass

Table 15. Conducted Emissions, 15.207, Phase Line, Test Results

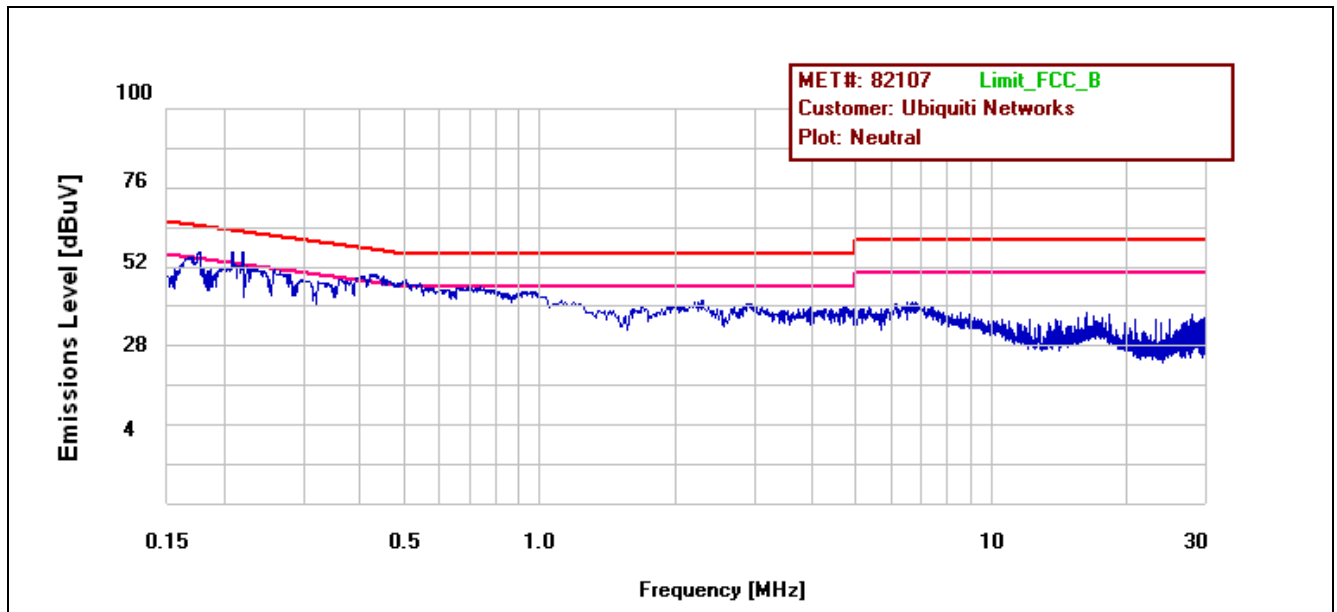


Plot 6. Conducted Emissions, Phase Line Plot

### 15.207 Conducted Emissions Test Results

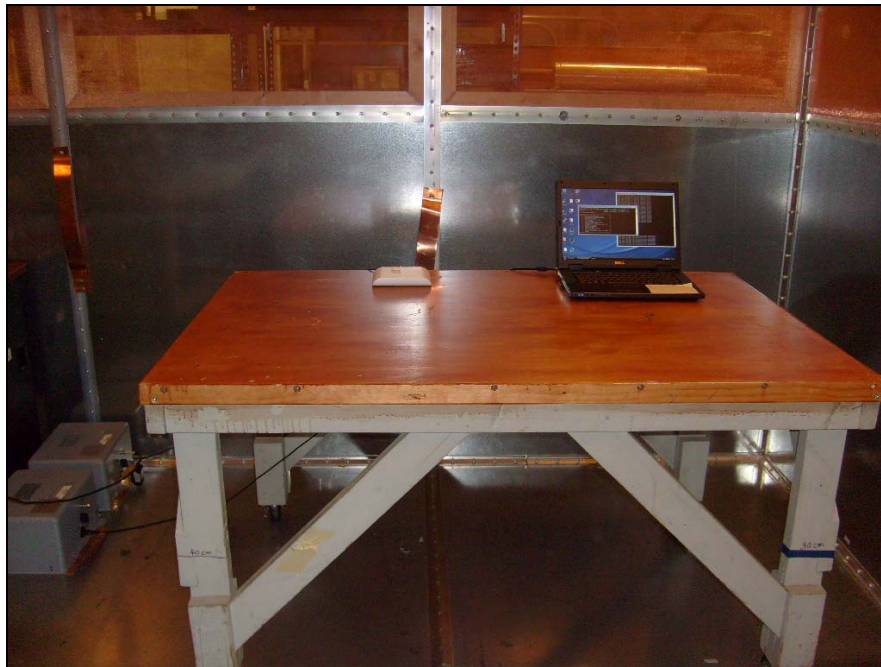
Freq (MHz)	QP Amplitude	QP Limit	Delta	Pass	Average Amplitude	Average Limit	Delta	Pass
.164	51.56	65.261	-13.701	Pass	42.72	55.261	-12.541	Pass
.235	48.45	62.281	-13.831	Pass	34.17	52.281	-18.111	Pass
.433	45.84	57.219	-11.379	Pass	34.55	47.219	-12.669	Pass
.540	42.82	56	-13.18	Pass	25.91	46	-20.09	Pass

Table 16. Conducted Emissions, 15.207, Neutral Line, Test Results



Plot 7. Conducted Emissions, Neutral Line Plot

### 15.207 Conducted Emissions Test Setup Photo



**Photograph 5. Conducted Emissions, 15.207, Test Setup**



**Photograph 6. Conducted Emissions, 15.207, Test Setup, Side View**

## Electromagnetic Compatibility Criteria for Intentional Radiators

### § 15.247(a) 6 dB and 99% Bandwidth

**Test Requirements:** § 15.247(a): Operation under the provisions of this section is limited to frequency hopping and digitally modulated intentional radiators that comply with the following provisions:

For systems using digital modulation techniques, the EUT may operate in the 902-928 MHz, 2400-2483.5 MHz and 5725-5850 MHz bands. The minimum 6dB bandwidth shall be at least 500 kHz.

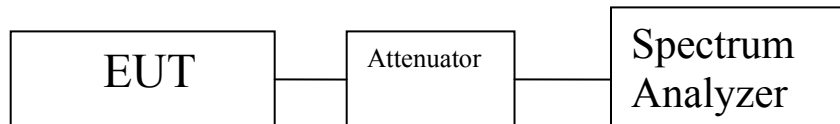
**Test Procedure:** The transmitter was on and transmitting at the highest output power. The bandwidth of the fundamental frequency was measured with the spectrum analyzer using a RBW approximately 1% of the total emission bandwidth, VBW > RBW. The 6 dB Bandwidth was measured and recorded. The measurements were performed on the low, mid and high channels.

**Test Results** The EUT was compliant with § 15.247 (a).

The 6 dB and 99% Bandwidth was determined from the plots on the following pages.

**Test Engineer(s):** Anderson Soungpanya

**Test Date(s):** 01/22/10



**Figure 2. Block Diagram, Occupied Bandwidth Test Setup**

## Occupied Bandwidth Test Results

Occupied Bandwidth			
Carrier Channel	Frequency (MHz)	Measured 6 dB Bandwidth (MHz)	Measured 99% Bandwidth (MHz)
Low	2412	15.8662	15.6349
Mid	2437	15.9084	16.1552
High	2462	16.0557	15.7569

Table 17. Occupied Bandwidth 802.11b Mode, Test Results

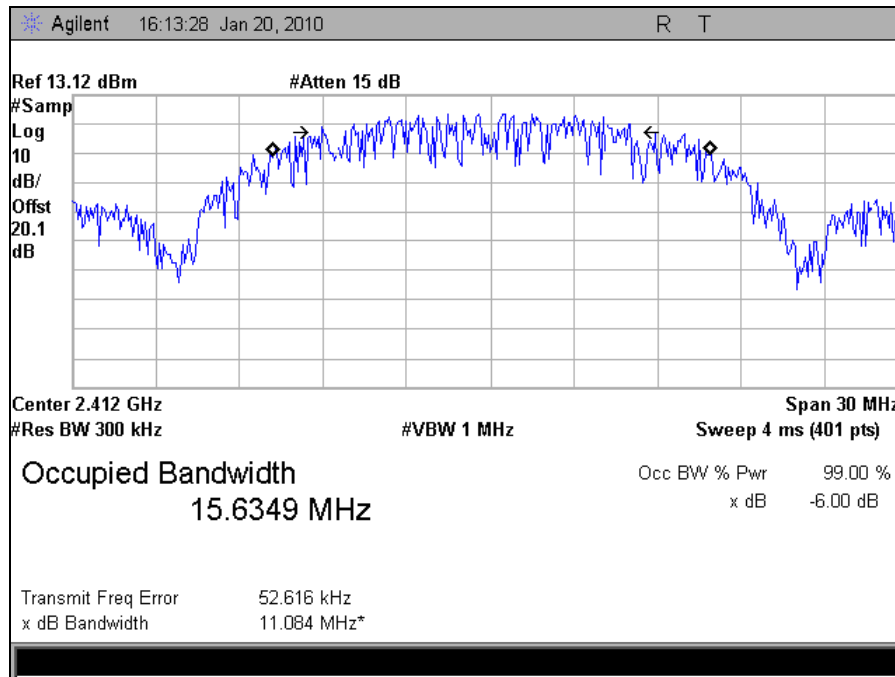
Occupied Bandwidth			
Carrier Channel	Frequency (MHz)	Measured 6 dB Bandwidth (MHz)	Measured 99% Bandwidth (MHz)
Low	2412	16.8544	16.7407
Mid	2437	17.7048	16.8862
High	2462	16.8758	17.3647

Table 18. Occupied Bandwidth 802.11g Mode, Test Results

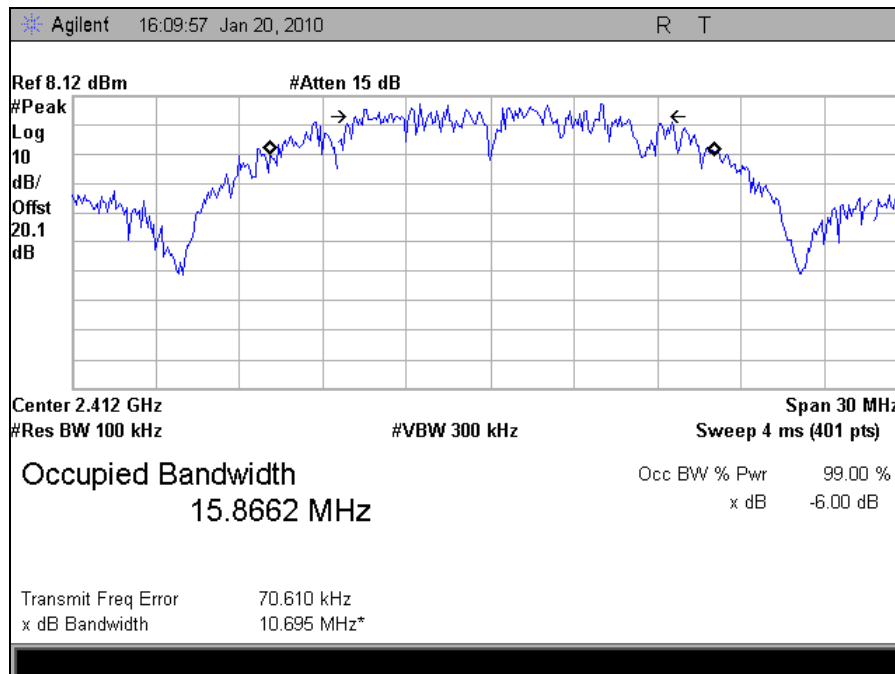
Occupied Bandwidth			
Carrier Channel	Frequency (MHz)	Measured 6 dB Bandwidth (MHz)	Measured 99% Bandwidth (MHz)
Low	2412	18.0876	18.0813
Mid	2437	18.0595	17.9637
High	2462	17.8775	18.2719

Table 19. Occupied Bandwidth 802.11n Mode, Test Results

## Occupied Bandwidth Test Results – 802.11b Mode

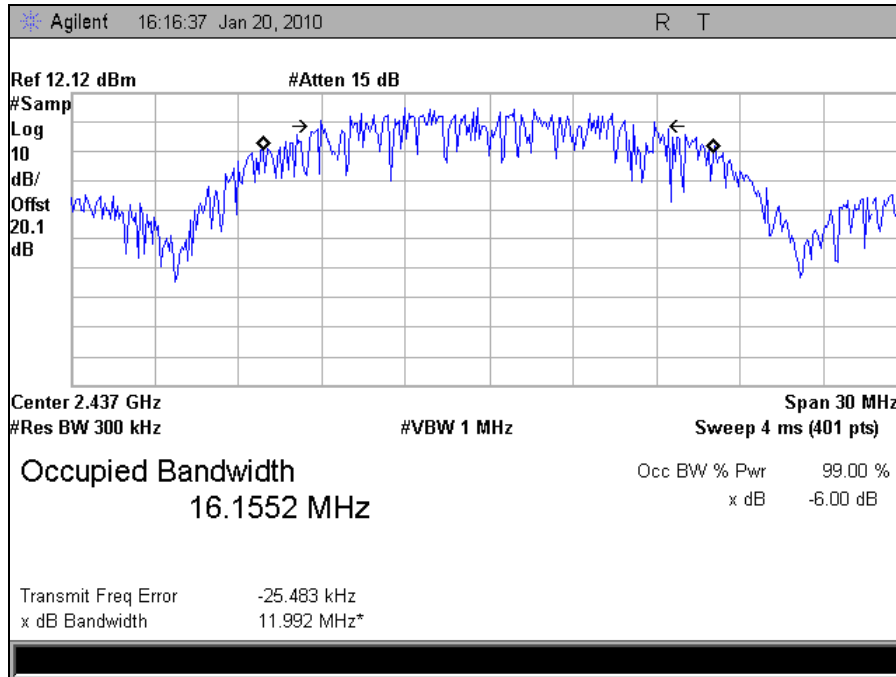


Plot 8. Occupied Bandwidth Low Channel, 802.11b (99%)

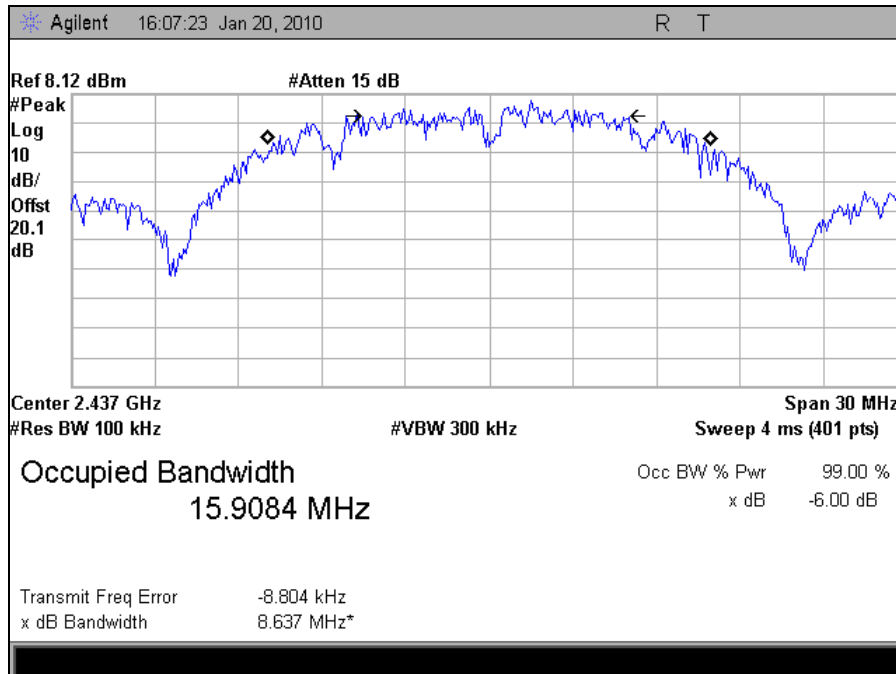


Plot 9. Occupied Bandwidth Low Channel, 802.11b (FCC)

### Occupied Bandwidth Test Results – 802.11b Mode

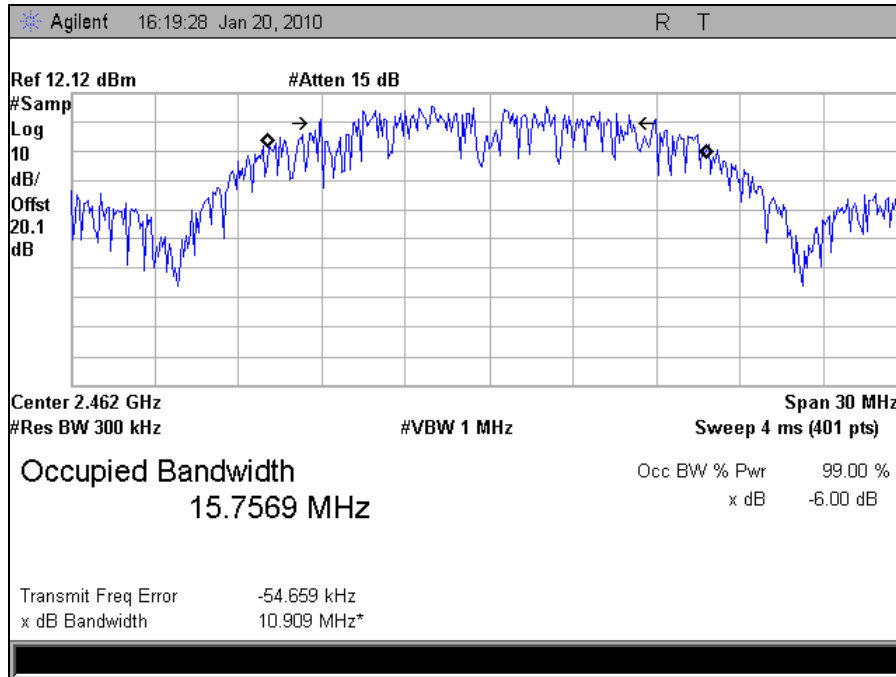


Plot 10. Occupied Bandwidth Mid Channel, 802.11b (99%)

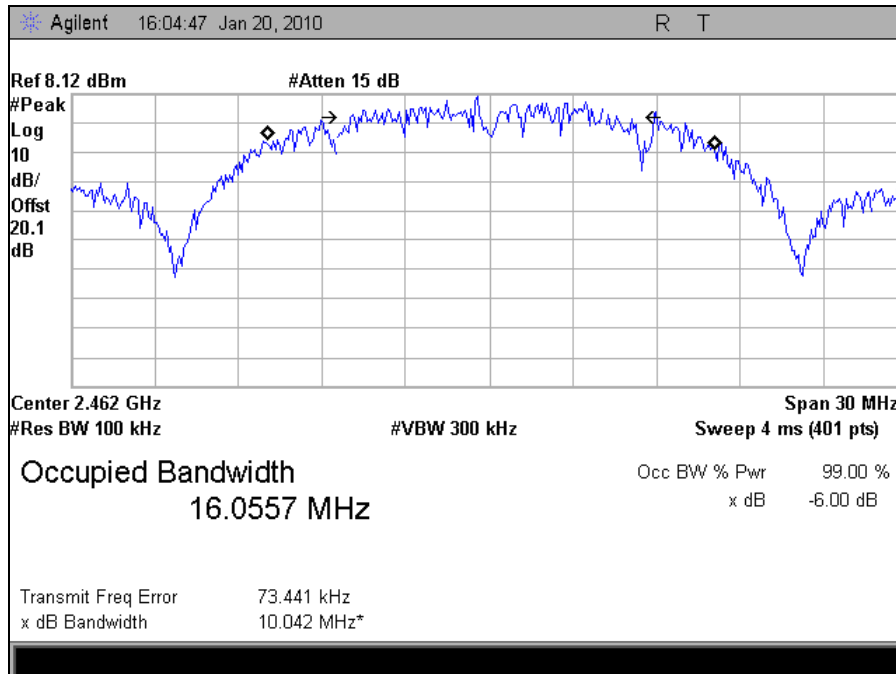


Plot 11. Occupied Bandwidth Mid Channel, 802.11b (FCC)

### Occupied Bandwidth Test Results – 802.11b Mode



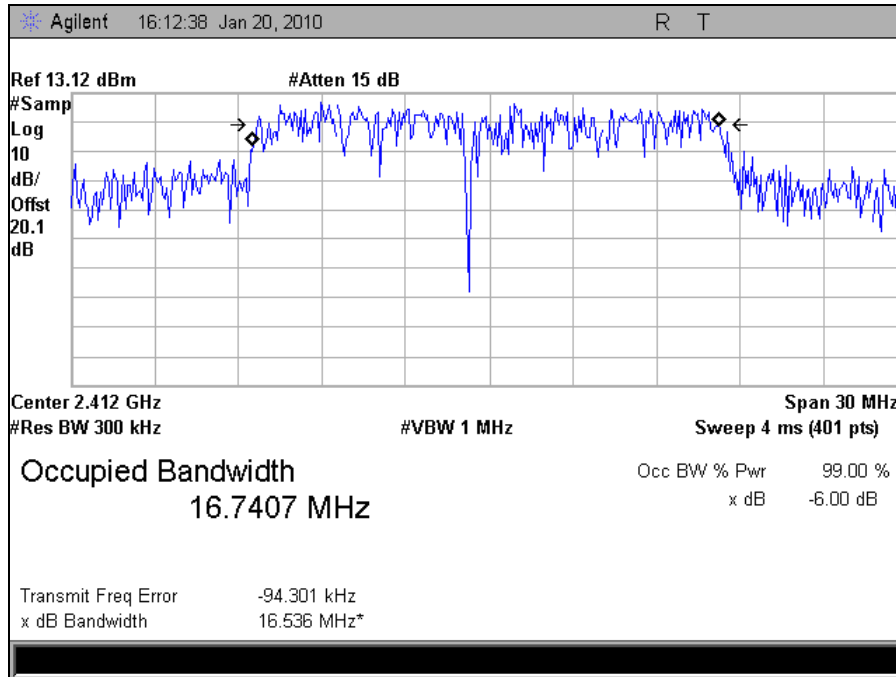
**Plot 12. Occupied Bandwidth High Channel, 802.11b (99%)**



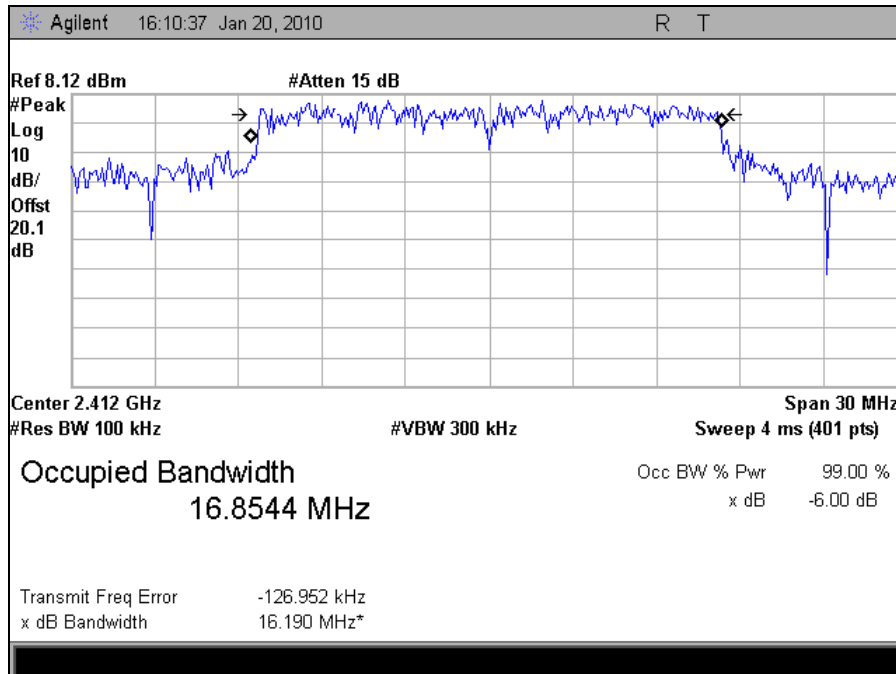
**Plot 13. Occupied Bandwidth High Channel, 802.11b (FCC)**



### Occupied Bandwidth Test Results – 802.11g Mode

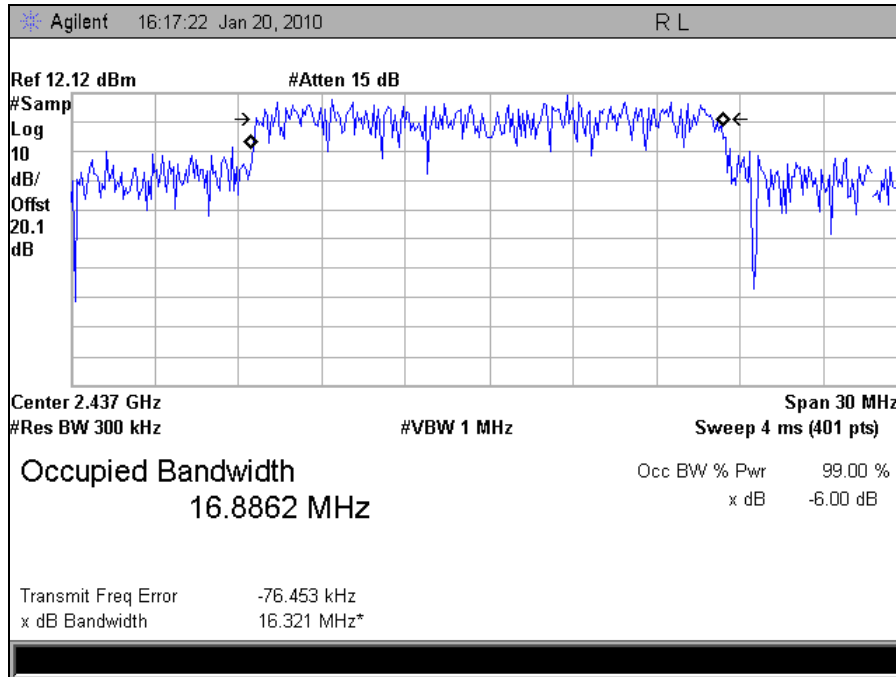


**Plot 14. Occupied Bandwidth Low Channel, 802.11g (99%)**

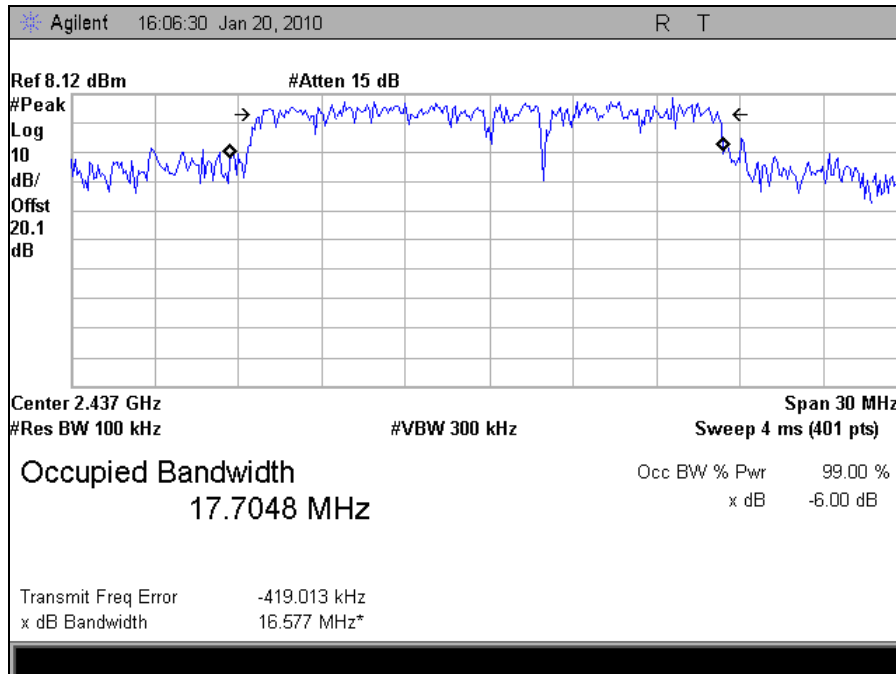


**Plot 15. Occupied Bandwidth Low Channel, 802.11g (FCC)**

### Occupied Bandwidth Test Results – 802.11g Mode

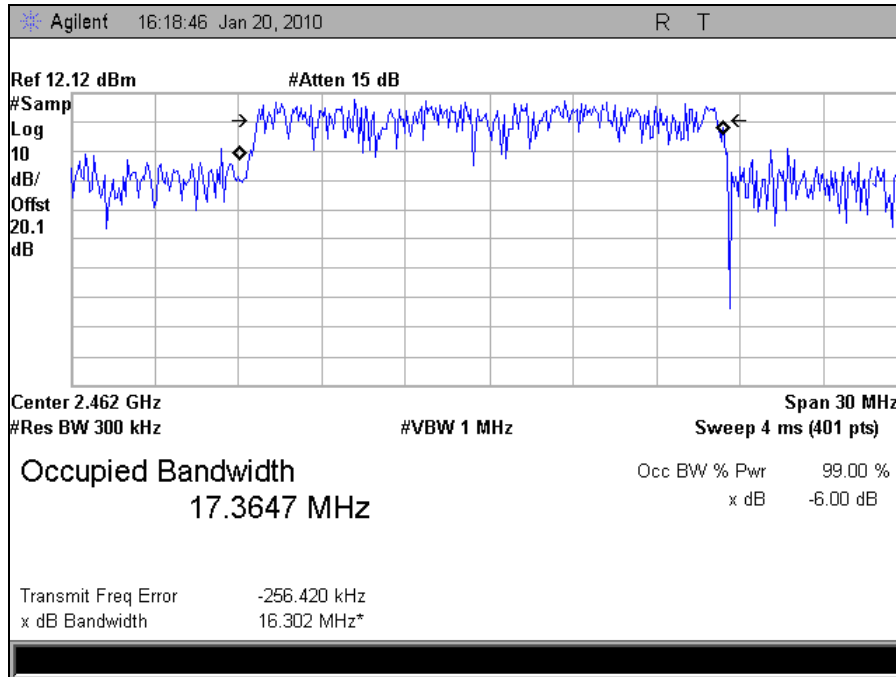


**Plot 16. Occupied Bandwidth Mid Channel, 802.11g (99%)**

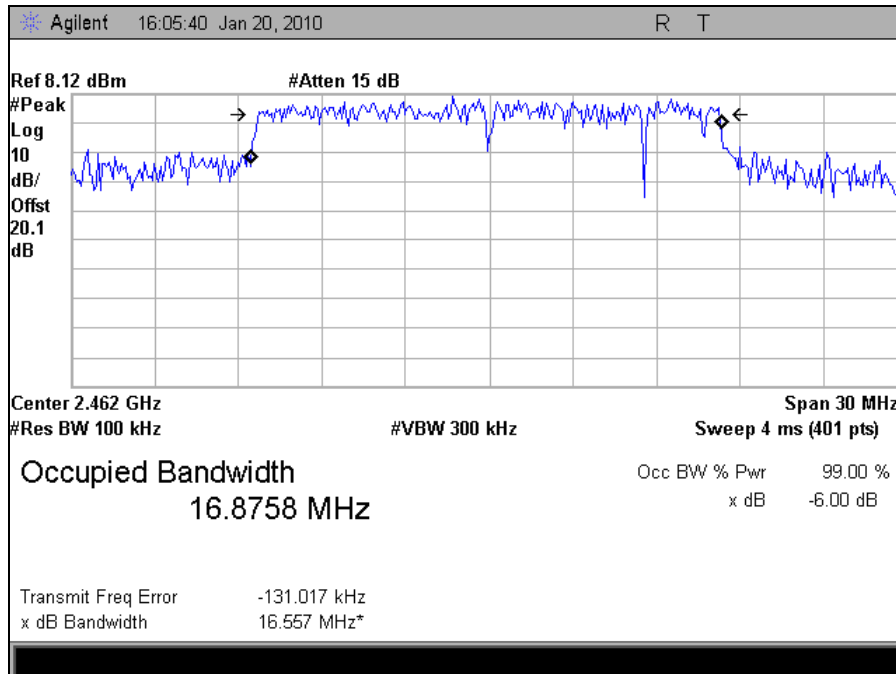


**Plot 17. Occupied Bandwidth Mid Channel, 802.11g (FCC)**

### Occupied Bandwidth Test Results – 802.11g Mode

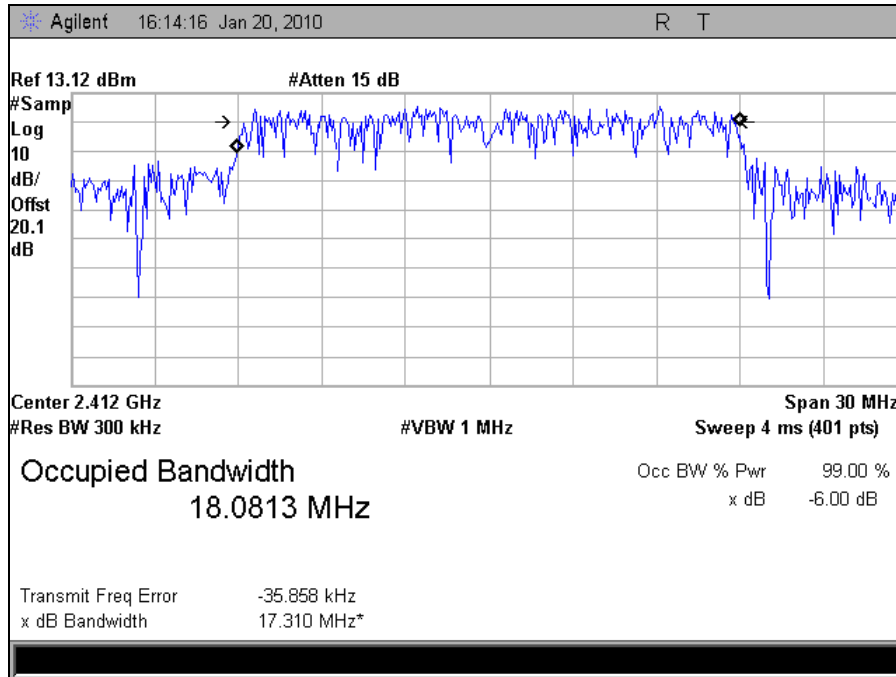


**Plot 18. Occupied Bandwidth High Channel, 802.11g (99%)**

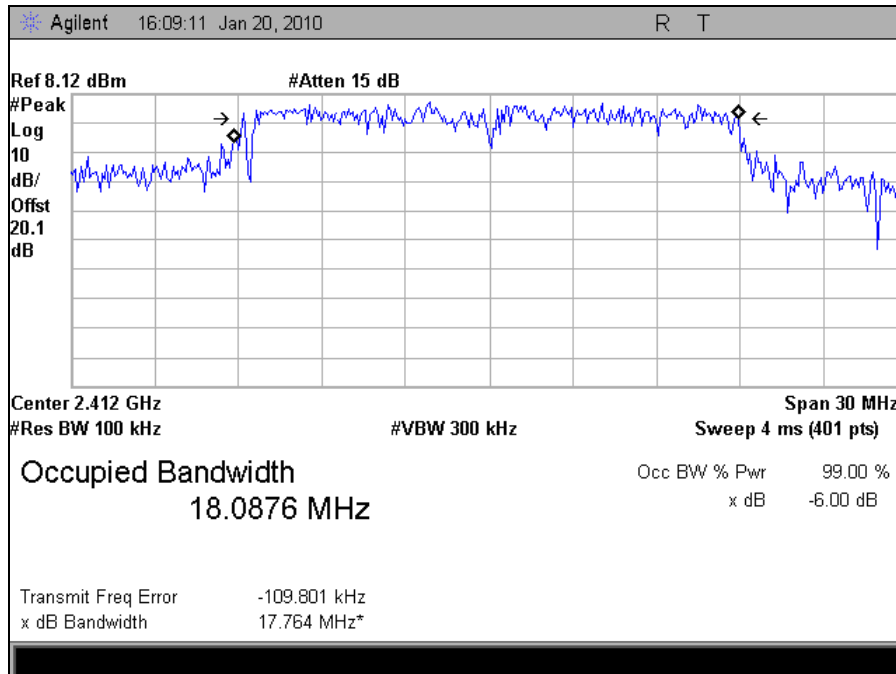


**Plot 19. Occupied Bandwidth High Channel, 802.11g (FCC)**

### Occupied Bandwidth Test Results – 802.11n Mode

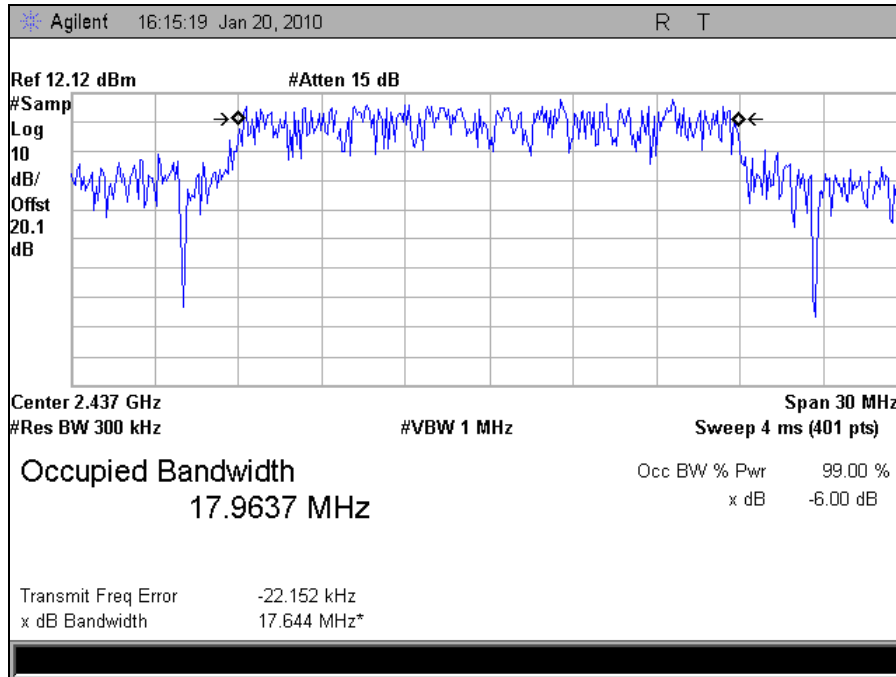


Plot 20. Occupied Bandwidth Low Channel, 802.11n (99%)

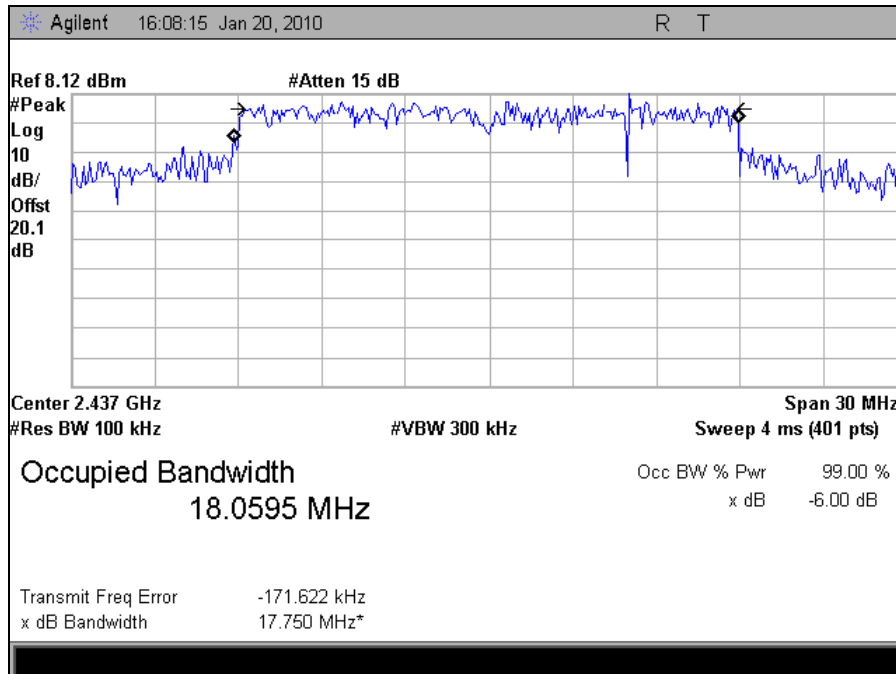


Plot 21. Occupied Bandwidth Low Channel, 802.11n (FCC)

### Occupied Bandwidth Test Results – 802.11n Mode

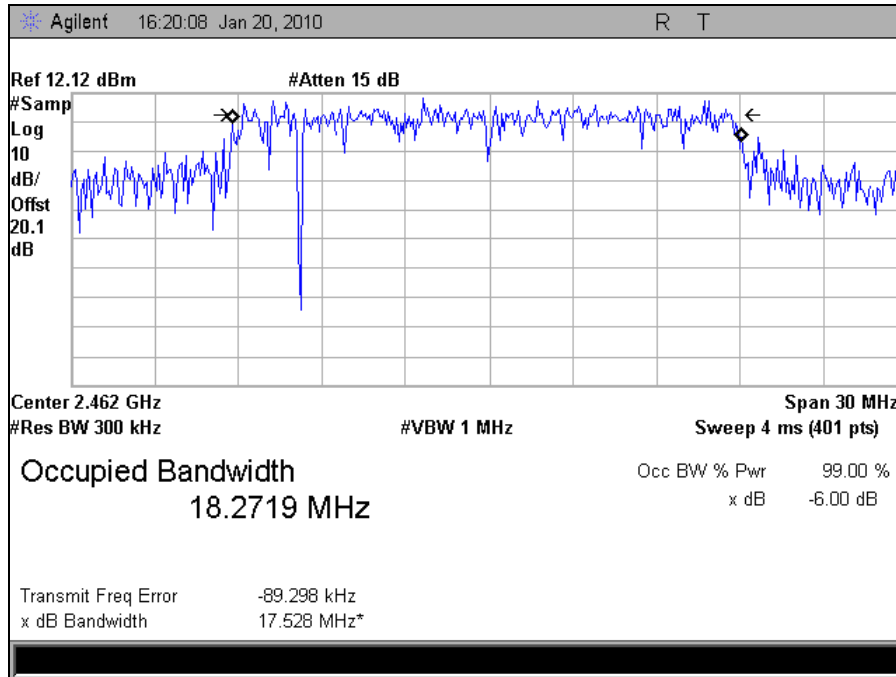


Plot 22. Occupied Bandwidth Mid Channel, 802.11n (99%)

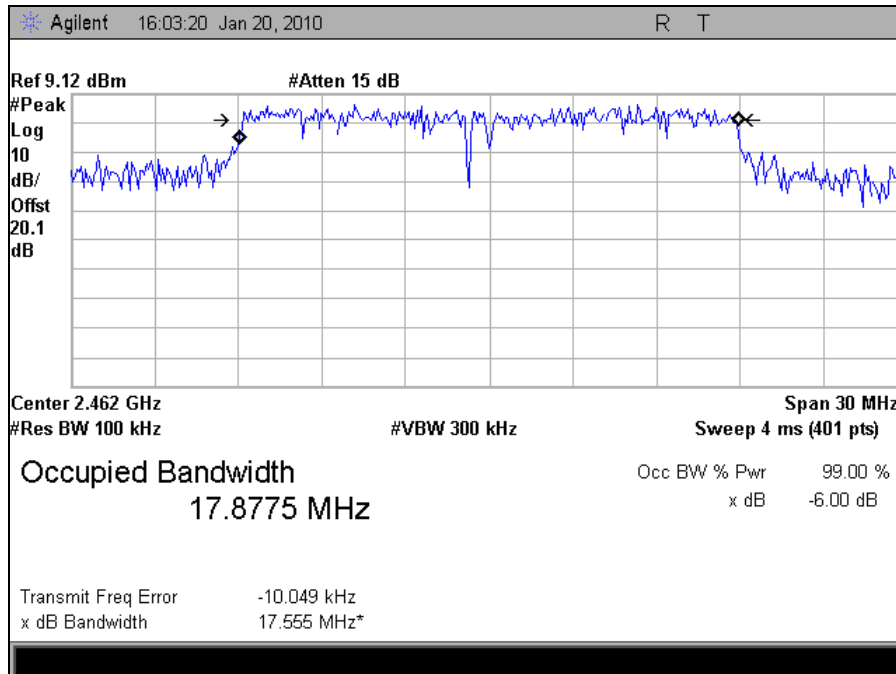


Plot 23. Occupied Bandwidth Mid Channel, 802.11n (FCC)

### Occupied Bandwidth Test Results – 802.11n Mode



Plot 24. Occupied Bandwidth High Channel, 802.11n (99%)



Plot 25. Occupied Bandwidth High Channel, 802.11n (FCC)

## Electromagnetic Compatibility Criteria for Intentional Radiators

### § 15.247(b) Peak Power Output and RF Exposure

**Test Requirements:** §15.247(b): The maximum peak output power of the intentional radiator shall not exceed the following:

Digital Transmission Systems (MHz)	Output Limit (Watts)
902-928	1.000
2400-2483.5	1.000
5725- 5850	1.000

**Table 20. Output Power Requirements from §15.247**

§15.247(c): if transmitting antennas of directional gain greater than 6 dBi are used the peak output power from the intentional radiator shall be reduced below the stated values in the Table 20, as appropriate, by the amount in dB that the directional gain of the antenna exceeds 6 dBi.

Systems operating in the 2400 – 2483.5 MHz band and using a point to point application may employ transmitting antennas with directional gain greater than 6 dBi provided the maximum peak output power of the intentional radiator is reduced by 1 dB for every 3 dB that the directional gain of the antenna exceeds 6 dBi.

Systems operating in the 5725 – 5850 MHz band that are used exclusively for fixed, point-to-point operations may employ transmitting antennas with directional gain greater than 6 dBi without any corresponding reduction in transmitter peak output power.

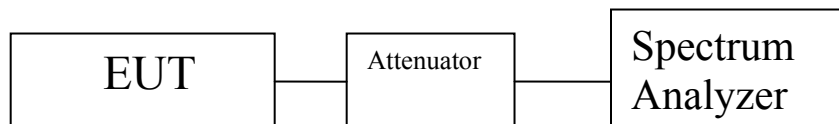
Fixed, point-to-point operation excludes the use of point-to-multipoint systems, omnidirectional applications, and multiple co-located intentional radiators transmitting the same information. The operator of the spread spectrum intentional radiator or, if the equipment is professionally installed, the installer is responsible for ensuring that the system is used exclusively for fixed, point-to-point operations. The instruction manual furnished with the intentional radiator shall contain language in the installation instructions informing the operator and the installer of this responsibility.

**Test Procedure:** The transmitter was connected to a calibrated spectrum analyzer. The EUT was measured at the low, mid and high channels of each band at the maximum power level.

**Test Results:** The EUT was compliant with the Peak Power Output limits of §15.247(b).

**Test Engineer(s):** Anderson Soungpanya

**Test Date(s):** 01/22/10



**Figure 3. Peak Power Output Test Setup**

## RF Power Output Test Results

Peak Conducted Output Power		
Carrier Channel	Frequency (MHz)	Measured Peak Output Power dBm
Low	2412	26.38
Mid	2437	26.57
High	2462	21.00

Table 21. RF Output Power, 802.11b, Test Results

Peak Conducted Output Power		
Carrier Channel	Frequency (MHz)	Measured Peak Output Power dBm
Low	2412	20.79
Mid	2437	26.67
High	2462	19.04

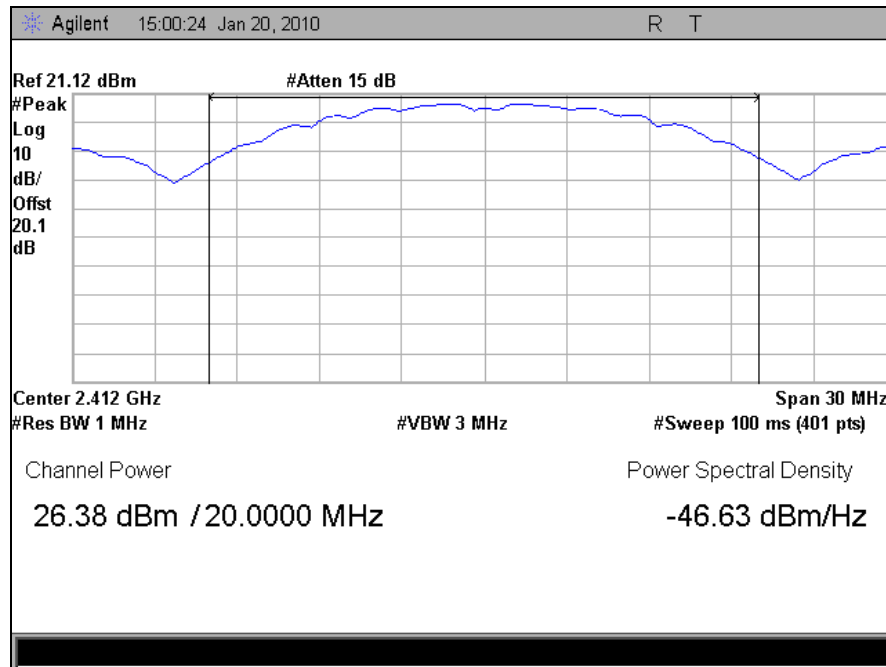
Table 22. RF Output Power, 802.11g, Test Results

Peak Conducted Output Power		
Carrier Channel	Frequency (MHz)	Measured Peak Output Power dBm
Low	2412	18.28
Mid	2437	26.19
High	2462	19.10

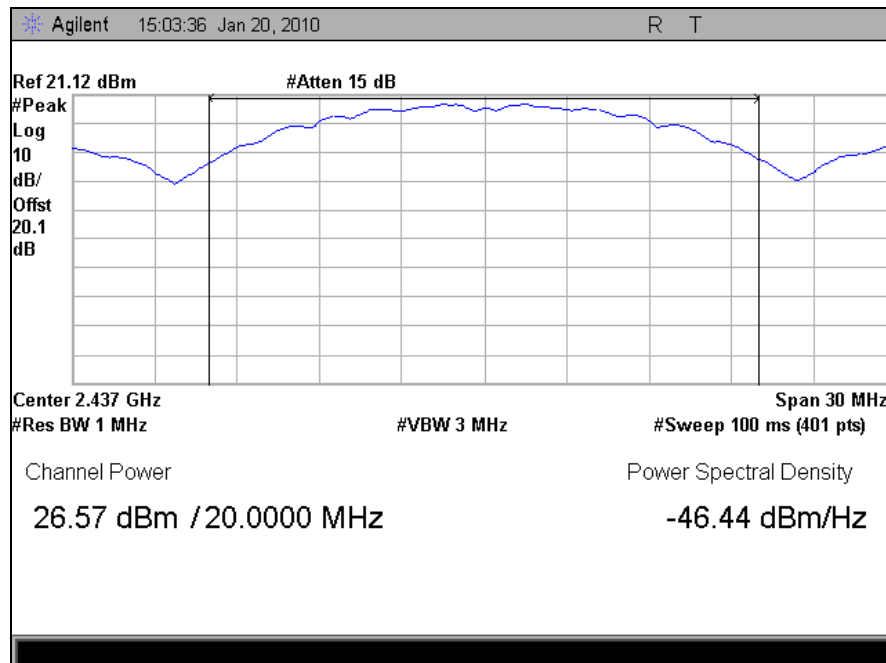
Table 23. RF Output Power, 802.11n, Test Results



## RF Output Power Test Results

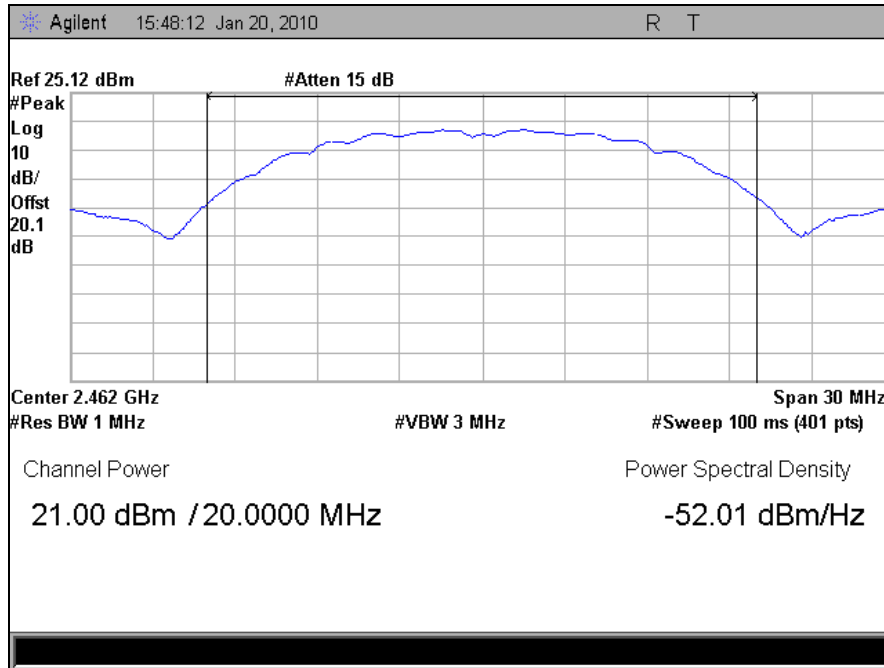


**Plot 26. Peak Power Output, 802.11b, Low Channel**

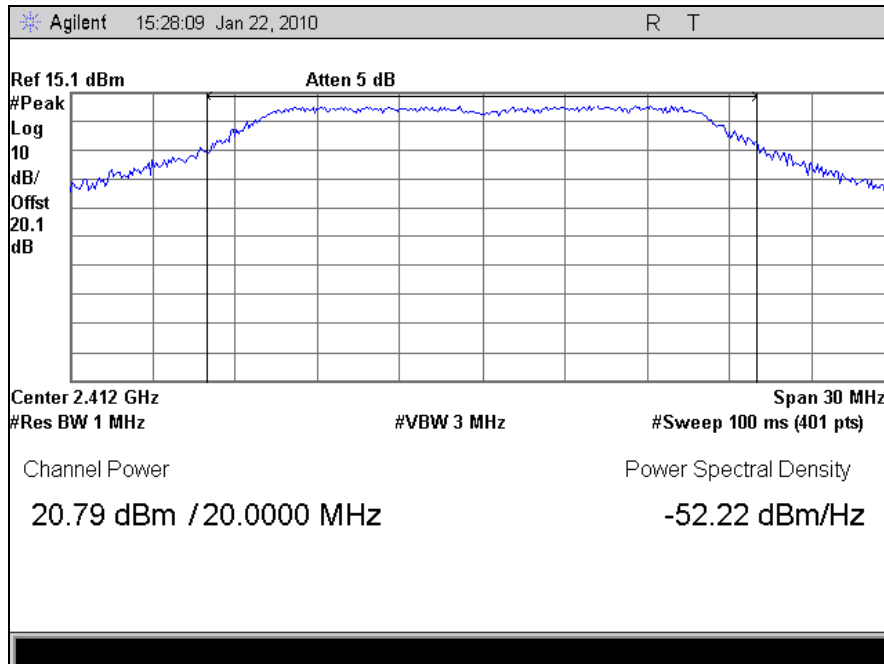


**Plot 27. Peak Power Output, 802.11b, Mid Channel**

### RF Output Power Test Results

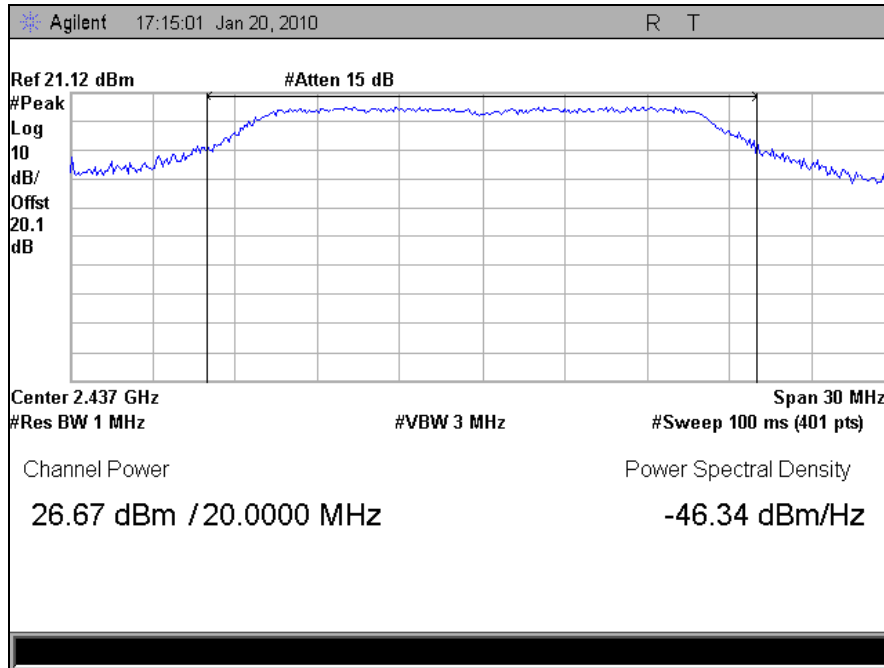


**Plot 28. Peak Power Output, 802.11b, High Channel**

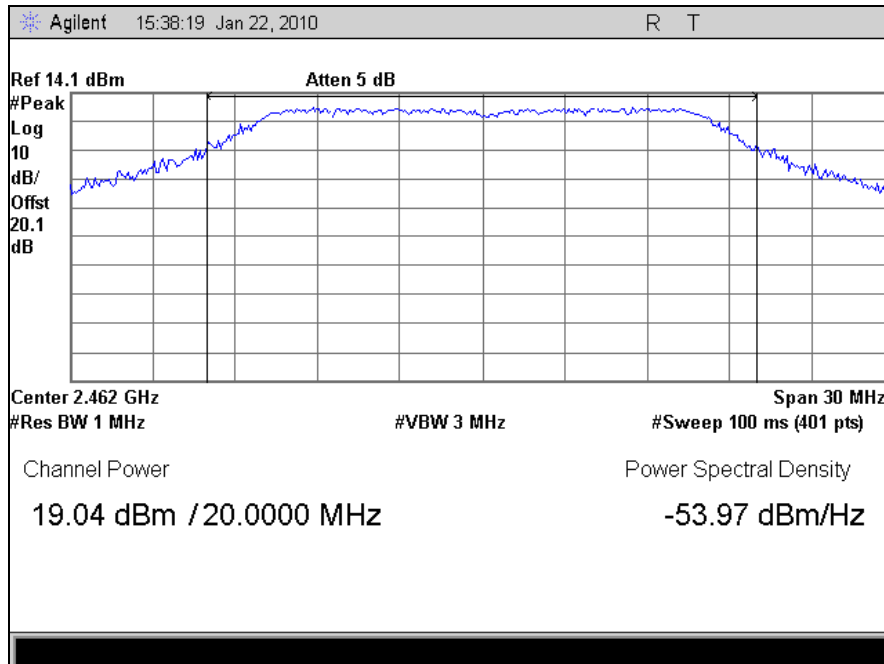


**Plot 29. Peak Power Output, 802.11g, Low Channel**

## RF Output Power Test Results

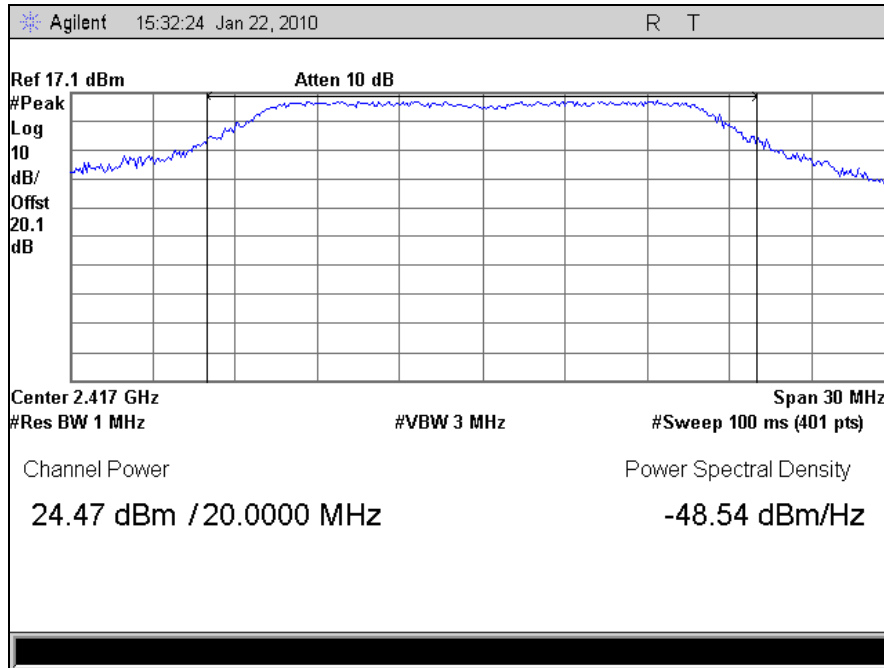


Plot 30. Peak Power Output, 802.11g, Mid Channel

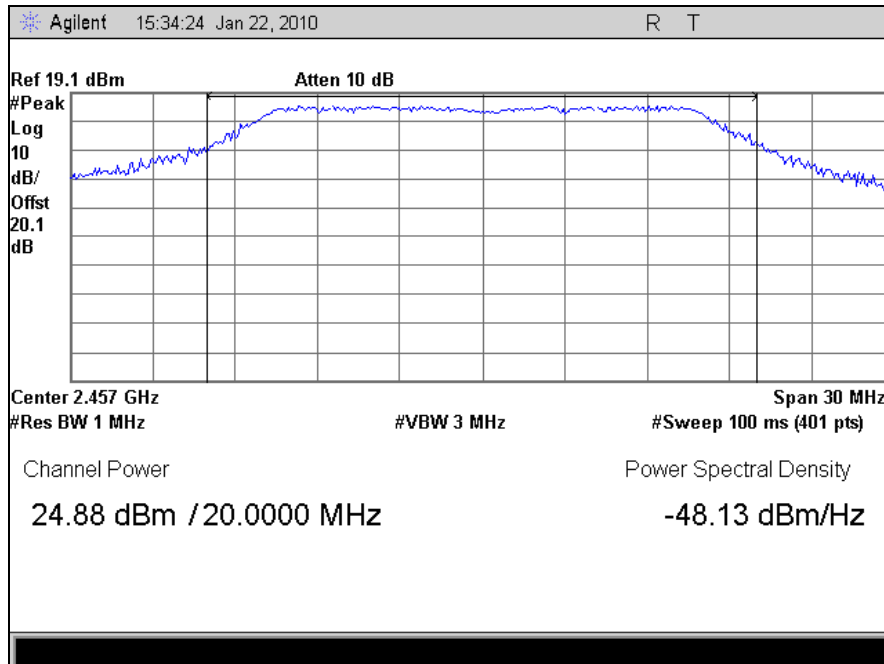


Plot 31. Peak Power Output, 802.11g, High Channel

## RF Output Power Test Results

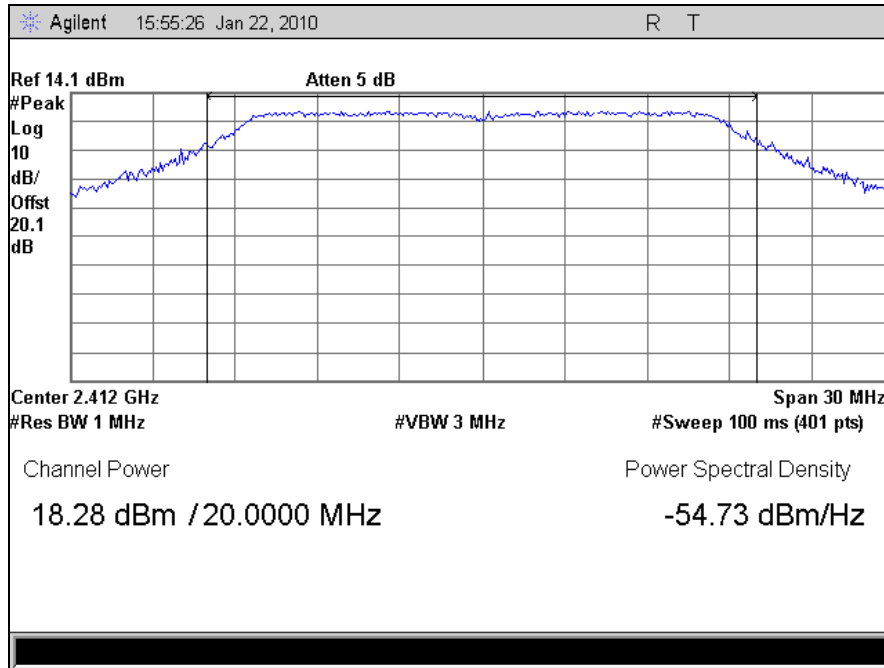


**Plot 32. Peak Power Output, Channel 2, 802.11g**

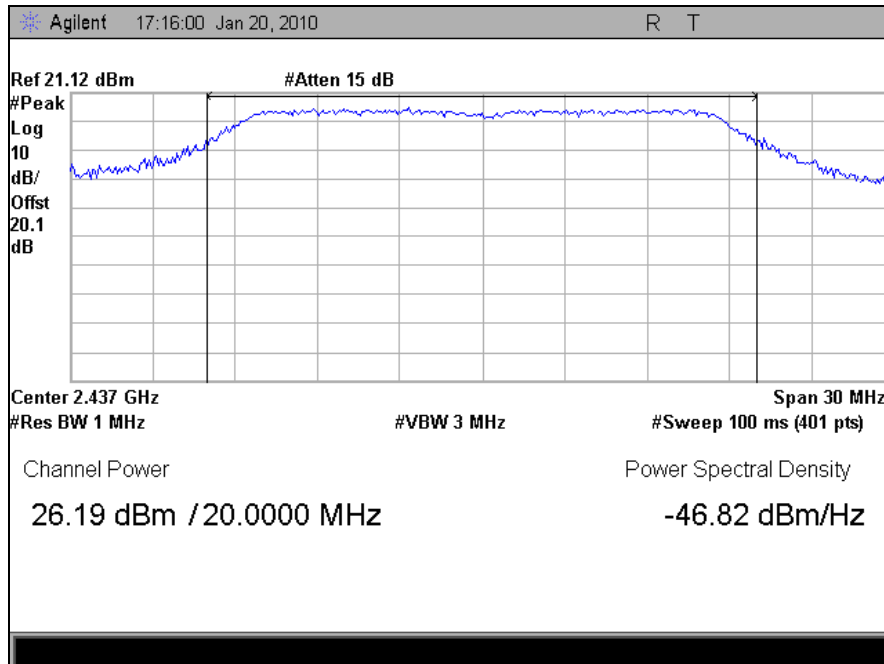


**Plot 33. Peak Power Output, Channel 10, 802.11g**

### RF Output Power Test Results

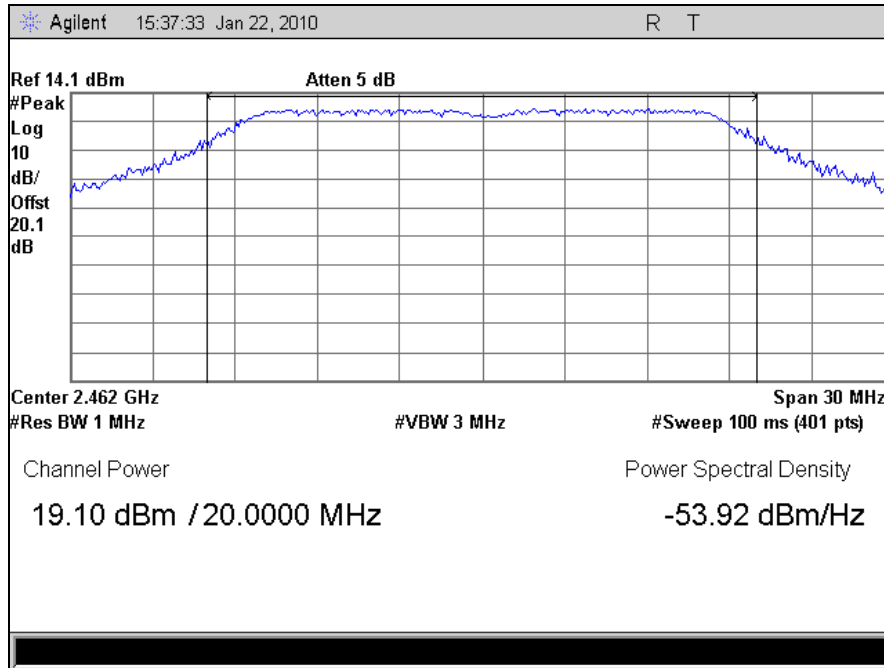


**Plot 34. Peak Power Output, 802.11n, Low Channel**

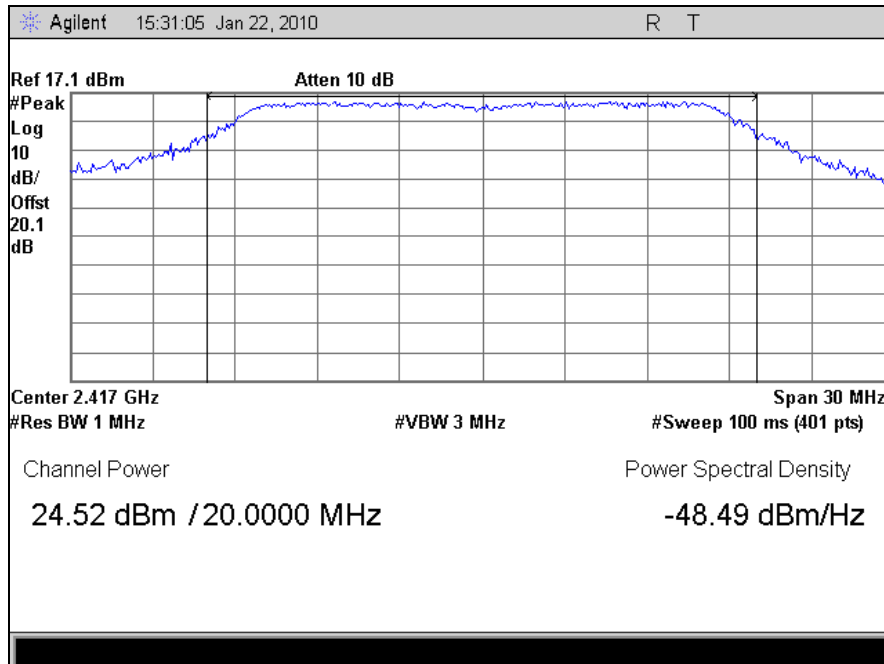


**Plot 35. Peak Power Output, 802.11n, Mid Channel**

### RF Output Power Test Results

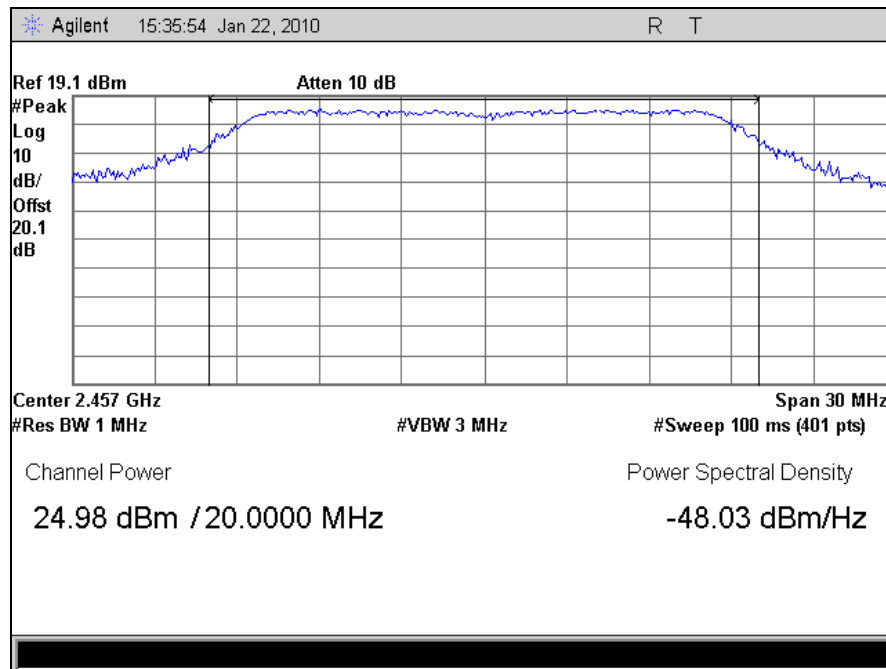


**Plot 36. Peak Power Output, 802.11n, High Channel**



**Plot 37. Peak Power Output, 802.11n, Channel 2**

## RF Output Power Test Results



Plot 38. Peak Power Output, 802.11n, Channel 10

## Electromagnetic Compatibility Criteria for Intentional Radiators

### § 15.247(b) RF Exposure

**RF Exposure Requirements:** §1.1307(b)(1) and §1.1307(b)(2): Systems operating under the provisions of this section shall be operated in a manner that ensures that the public is not exposed to radio frequency energy levels in excess of the Commission's guidelines.

**RF Radiation Exposure Limit:** §1.1310: As specified in this section, the Maximum Permissible Exposure (MPE) Limit shall be used to evaluate the environmental impact of human exposure to radiofrequency (RF) radiation as specified in Sec. 1.1307(b), except in the case of portable devices which shall be evaluated according to the provisions of Sec. 2.1093 of this chapter.

MPE Limit Calculation: EUT's operating frequencies @ 2412-2462 MHz; highest conducted power = **26.67dBm** (peak) therefore, **Limit for Uncontrolled exposure: 1 mW/cm<sup>2</sup> or 10 W/m<sup>2</sup>**

EUT maximum antenna gain = **0dBi. Integral**

Equation from page 18 of OET 65, Edition 97-01

$$S = PG / 4\pi R^2 \quad \text{or} \quad R = \sqrt{PG / 4\pi S}$$

where, S = Power Density (1 mW/cm<sup>2</sup>)  
P = Power Input to antenna (465.6mW)  
G = Antenna Gain (1.0 numeric)

$$S = (465.6 * 1 / 4 * 3.14 * 20.02) = (464.6 / 5024) = 0.0924 \text{ mW/cm}^2 \text{ @ 20cm separation}$$



## Electromagnetic Compatibility Criteria for Intentional Radiators

### § 15.247(d) Radiated Spurious Emissions Requirements and Band Edge

**Test Requirements:** §15.247(d); §15.205: Emissions outside the frequency band.

**§15.247(d):** In any 100 kHz bandwidth outside the frequency band in which the spread spectrum or digitally modulated intentional radiator is operating, the radio frequency power that is produced by the intentional radiator shall be at least 20 dB below that in the 100 kHz bandwidth within the band that contains the highest level of the desired power, based on either an RF conducted or a radiated measurement. Attenuation below the general limits specified in § 15.209(a) is not required. In addition, radiated emissions which fall in the restricted bands, as defined in § 15.205(a), must also comply with the radiated emission limits specified in § 15.209(a).

**§15.205(a):** Except as shown in paragraph (d) of this section, only spurious emissions are permitted in any of the frequency bands listed below:

MHz	MHz	MHz	GHz
0.090–0.110-----	16.42–16.423	399.9–410	4.5–5.15
<sup>1</sup> 0.495–0.505-----	16.69475–16.69525	608–614	5.35–5.46
2.1735–2.1905-----	16.80425–16.80475	960–1240	7.25–7.75
4.125–4.128-----	25.5–25.67	1300–1427	8.025–8.5
4.17725–4.17775-----	37.5–38.25	1435–1626.5	9.0–9.2
4.20725–4.20775-----	73–74.6	1645.5–1646.5	9.3–9.5
6.215–6.218-----	74.8–75.2	1660–1710	10.6–12.7
6.26775–6.26825-----	108–121.94	1718.8–1722.2	13.25–13.4
6.31175–6.31225-----	123–138	2200–2300	14.47–14.5
8.291–8.294-----	149.9–150.05	2310–2390	15.35–16.2
8.362–8.366-----	156.52475–156.52525	2483.5–2500	17.7–21.4
8.37625–8.38675-----	156.7–156.9	2655–2900	22.01–23.12
8.41425–8.41475-----	162.0125–167.17	3260–3267	23.6–24.0
12.29–12.293-----	167.72–173.2	3332–3339	31.2–31.8
12.51975–12.52025-----	240–285	3345.8–3358 36.	43–36.5
12.57675–12.57725-----	322–335.4	3600–4400	( <sup>2</sup> )

**Table 24. Restricted Bands of Operation**

<sup>1</sup> Until February 1, 1999, this restricted band shall be 0.490 – 0.510 MHz.

<sup>2</sup> Above 38.6

**Test Requirement(s):** § 15.209 (a): Except as provided elsewhere in this subpart, the emissions from an intentional radiator shall not exceed the field strength levels specified in Table 25.

Frequency (MHz)	§ 15.209(a), Radiated Emission Limits (dB $\mu$ V) @ 3m
30 - 88	40.00
88 - 216	43.50
216 - 960	46.00
Above 960	54.00

**Table 25. Radiated Emissions Limits Calculated from FCC Part 15, § 15.209 (a)**

**Test Procedures:** The transmitter was turned. Measurements were performed of the low, mid and high Channels. The EUT was rotated orthogonally through all three axes. Plots shown are corrected for both antenna correction factor and distance and compared to a 3 m limit line. Only noise floor was measured above 18 GHz.

**Test Results:** The EUT was compliant with the Radiated Spurious Emission limits of § 15.247(d). Measured emissions were below applicable limits.

**Test Engineer(s):** Anderson Soungpanya

**Test Date(s):** 01/22/10

## Harmonic Emissions Requirements – Radiated

Freq. (GHz)	Antenna Polarity (H/V)	Raw Amp. @ 3 m (Peak) / (Avg.)	P. Amp (dB)	Ant. Cor. Factor (dB/m)	Cable Loss (dB)	EUT Field Strength Final Amp. (dBuV/m)	Limit Detector Peak / Avg.	Limit @ 3 m (dBuV/m)	Delta (dB)
4.824	V	49.61	34.76	33.95	4.37	53.17	Peak	74	-20.83
4.824	V	44.43	34.76	33.95	4.37	47.99	Avg.	54	-6.01
7.236	V	44.74	35.01	35.62	5.59	50.94	Peak	74	-23.06
7.236	V	31.96	35.01	35.62	5.59	38.16	Avg.	54	-15.84
9.648	V	48.22	35.58	36.61	6.25	55.51	Peak	74	-18.49
9.648	V	39.01	35.58	36.61	6.25	46.30	Avg.	54	-7.70

**Table 26. Radiated Harmonic Emissions, 802.11b, Low Channel, Test Results**

Note: All other emissions were measured at the noise floor of the spectrum analyzer.

Freq. (GHz)	Antenna Polarity (H/V)	Raw Amp. @ 3 m (Peak) / (Avg.)	P. Amp (dB)	Ant. Cor. Factor (dB/m)	Cable Loss (dB)	EUT Field Strength Final Amp. (dBuV/m)	Limit Detector Peak / Avg.	Limit @ 3 m (dBuV/m)	Delta (dB)
4.874	V	45.23	34.74	33.94	4.41	48.84	Peak	74	-25.16
4.874	V	34.05	34.74	33.94	4.41	37.66	Avg.	54	-16.34
7.311	V	44.62	35.02	35.64	5.93	51.17	Peak	74	-22.83
7.311	V	31.55	35.02	35.64	5.93	38.10	Avg.	54	-15.90
9.748	V	49.08	35.55	36.75	6.29	56.57	Peak	74	-17.43
9.748	V	41.41	35.55	36.75	6.29	48.90	Avg.	54	-5.10

**Table 27. Radiated Harmonic Emissions, 802.11b, Mid Channel, Test Results**

Note: All other emissions were measured at the noise floor of the spectrum analyzer.

Freq. (GHz)	Antenna Polarity (H/V)	Raw Amp. @ 3 m (Peak) / (Avg.)	P. Amp (dB)	Ant. Cor. Factor (dB/m)	Cable Loss (dB)	EUT Field Strength Final Amp. (dBuV/m)	Limit Detector Peak / Avg.	Limit @ 3 m (dBuV/m)	Delta (dB)
4.924	V	45.48	34.73	33.94	4.46	49.15	Peak	74	-24.85
4.924	V	32.91	34.73	33.94	4.46	36.58	Avg.	54	-17.42
7.386	V	43.91	35.05	35.65	6.24	50.75	Peak	74	-23.25
7.386	V	31.49	35.05	35.65	6.24	38.33	Avg.	54	-15.67
9.848	V	46.27	35.54	36.89	6.33	53.95	Peak	74	-20.05
9.848	V	35.31	35.54	36.89	6.33	42.99	Avg.	54	-11.01

**Table 28. Radiated Harmonic Emissions, 802.11b, High Channel, Test Results**

Note: All other emissions were measured at the noise floor of the spectrum analyzer.

## Harmonic Emissions Requirements – Radiated

Freq. (GHz)	Antenna Polarity (H/V)	Raw Amp. @ 3 m (Peak) / (Avg.)	P. Amp (dB)	Ant. Cor. Factor (dB/m)	Cable Loss (dB)	EUT Field Strength Final Amp. (dBuV/m)	Limit Detector Peak / Avg.	Limit @ 3 m (dBuV/m)	Delta (dB)
4.824	V	44.94	34.76	33.95	4.37	48.50	Peak	74	-25.50
4.824	V	32.01	34.76	33.95	4.37	35.57	Avg.	54	-18.43
7.236	V	44.22	35.01	35.62	5.59	50.42	Peak	74	-23.58
7.236	V	31.83	35.01	35.62	5.59	38.03	Avg.	54	-15.97
9.648	V	44.96	35.58	36.61	6.25	52.25	Peak	74	-21.75
9.648	V	32.21	35.58	36.61	6.25	39.50	Avg.	54	-14.50

**Table 29. Radiated Harmonic Emissions, 802.11g, Low Channel, Test Results**

Note: All other emissions were measured at the noise floor of the spectrum analyzer.

Freq. (GHz)	Antenna Polarity (H/V)	Raw Amp. @ 3 m (Peak) / (Avg.)	P. Amp (dB)	Ant. Cor. Factor (dB/m)	Cable Loss (dB)	EUT Field Strength Final Amp. (dBuV/m)	Limit Detector Peak / Avg.	Limit @ 3 m (dBuV/m)	Delta (dB)
4.874	V	44.67	34.74	33.94	4.41	48.28	Peak	74	-25.72
4.874	V	31.89	34.74	33.94	4.41	35.50	Avg.	54	-18.50
7.311	V	44.65	35.02	35.64	5.93	51.20	Peak	74	-22.80
7.311	V	31.57	35.02	35.64	5.93	38.12	Avg.	54	-15.88
9.748	V	45.91	35.55	36.75	6.29	53.40	Peak	74	-20.60
9.748	V	32.67	35.55	36.75	6.29	40.16	Avg.	54	-13.84

**Table 30. Radiated Harmonic Emissions, 802.11g, Mid Channel, Test Results**

Note: All other emissions were measured at the noise floor of the spectrum analyzer.

Freq. (GHz)	Antenna Polarity (H/V)	Raw Amp. @ 3 m (Peak) / (Avg.)	P. Amp (dB)	Ant. Cor. Factor (dB/m)	Cable Loss (dB)	EUT Field Strength Final Amp. (dBuV/m)	Limit Detector Peak / Avg.	Limit @ 3 m (dBuV/m)	Delta (dB)
4.924	V	44.69	34.73	33.94	4.46	48.36	Peak	74	-25.64
4.924	V	31.69	34.73	33.94	4.46	35.36	Avg.	54	-18.64
7.386	V	44.74	35.05	35.65	6.24	51.58	Peak	74	-22.42
7.386	V	32.1	35.05	35.65	6.24	38.94	Avg.	54	-15.06
9.848	V	45.73	35.54	36.89	6.33	53.41	Peak	74	-20.59
9.848	V	32.13	35.54	36.89	6.33	39.81	Avg.	54	-14.19

**Table 31. Radiated Harmonic Emissions, 802.11g, High Channel, Test Results**

Note: All other emissions were measured at the noise floor of the spectrum analyzer.

## Harmonic Emissions Requirements – Radiated

Freq. (GHz)	Antenna Polarity (H/V)	Raw Amp. @ 3 m (Peak) / (Avg.)	P. Amp (dB)	Ant. Cor. Factor (dB/m)	Cable Loss (dB)	EUT Field Strength Final Amp. (dBuV/m)	Limit Detector Peak / Avg.	Limit @ 3 m (dBuV/m)	Delta (dB)
4.824	V	44.92	34.76	33.95	4.37	48.48	Peak	74	-25.52
4.824	V	31.15	34.76	33.95	4.37	34.71	Avg.	54	-19.29
7.236	V	45.21	35.01	35.62	5.59	51.41	Peak	74	-22.59
7.236	V	31.91	35.01	35.62	5.59	38.11	Avg.	54	-15.89
9.648	V	44.55	35.58	36.61	6.25	51.84	Peak	74	-22.16
9.648	V	31.75	35.58	36.61	6.25	39.04	Avg.	54	-14.96

**Table 32. Radiated Harmonic Emissions, 802.11n, Low Channel, Test Results**

Note: All other emissions were measured at the noise floor of the spectrum analyzer.

Freq. (GHz)	Antenna Polarity (H/V)	Raw Amp. @ 3 m (Peak) / (Avg.)	P. Amp (dB)	Ant. Cor. Factor (dB/m)	Cable Loss (dB)	EUT Field Strength Final Amp. (dBuV/m)	Limit Detector Peak / Avg.	Limit @ 3 m (dBuV/m)	Delta (dB)
4.874	V	43.06	34.74	33.94	4.41	46.67	Peak	74	-27.33
4.874	V	30.91	34.74	33.94	4.41	34.52	Avg.	54	-19.48
7.311	V	43.95	35.02	35.64	5.93	50.50	Peak	74	-23.50
7.311	V	31.52	35.02	35.64	5.93	38.07	Avg.	54	-15.93
9.748	V	45.34	35.55	36.75	6.29	52.83	Peak	74	-21.17
9.748	V	32.57	35.55	36.75	6.29	40.06	Avg.	54	-13.94

**Table 33. Radiated Harmonic Emissions, 802.11n, Mid Channel, Test Results**

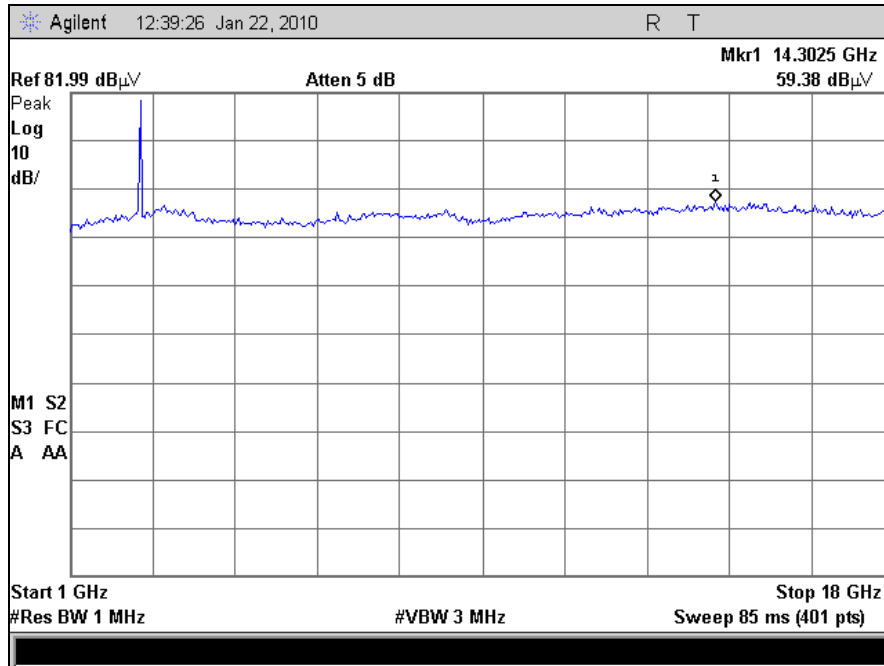
Note: All other emissions were measured at the noise floor of the spectrum analyzer.

Freq. (GHz)	Antenna Polarity (H/V)	Raw Amp. @ 3 m (Peak) / (Avg.)	P. Amp (dB)	Ant. Cor. Factor (dB/m)	Cable Loss (dB)	EUT Field Strength Final Amp. (dBuV/m)	Limit Detector Peak / Avg.	Limit @ 3 m (dBuV/m)	Delta (dB)
4.924	V	44.21	34.73	33.94	4.46	47.88	Peak	74	-26.12
4.924	V	30.71	34.73	33.94	4.46	34.38	Avg.	54	-19.62
7.386	V	44.51	35.05	35.65	6.24	51.35	Peak	74	-22.65
7.386	V	31.45	35.05	35.65	6.24	38.29	Avg.	54	-15.71
9.848	V	44.19	35.54	36.89	6.33	51.87	Peak	74	-22.13
9.848	V	31.72	35.54	36.89	6.33	39.40	Avg.	54	-14.60

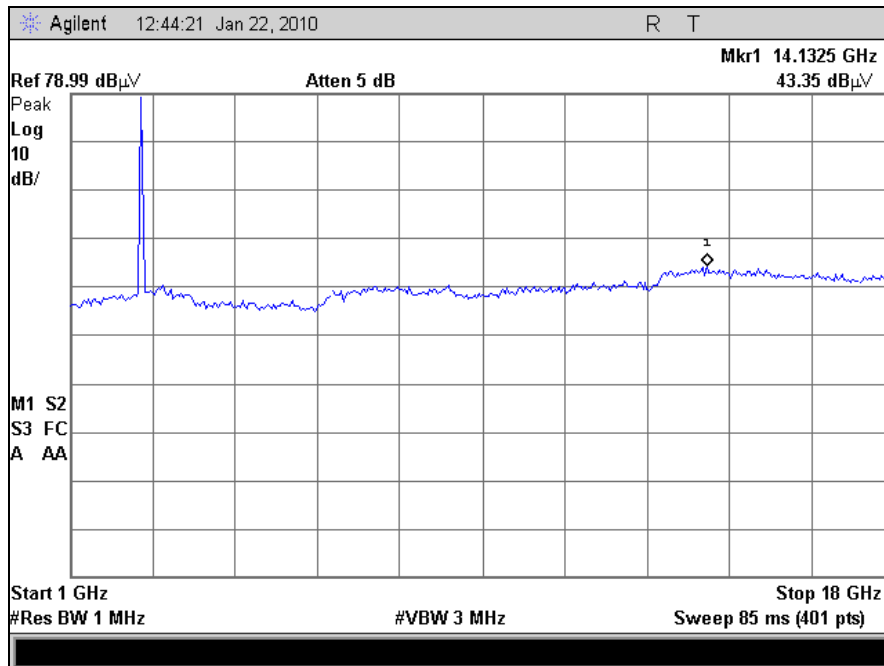
**Table 34. Radiated Harmonic Emissions, 802.11n, High Channel, Test Results**

Note: All other emissions were measured at the noise floor of the spectrum analyzer.

### Radiated Spurious Emissions Test Results

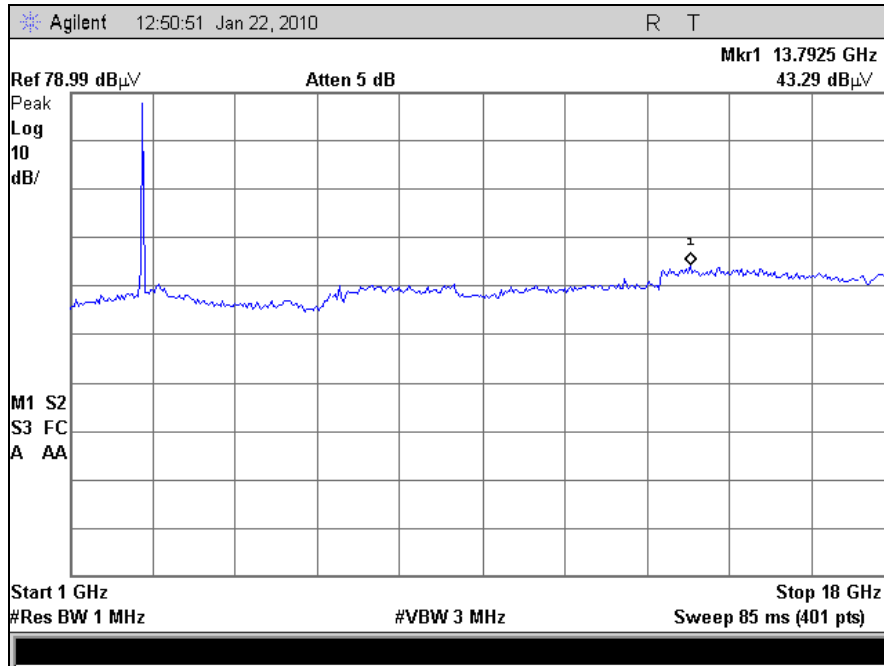


**Plot 39. Radiated Spurious Emissions, 802.11b, Low Channel**

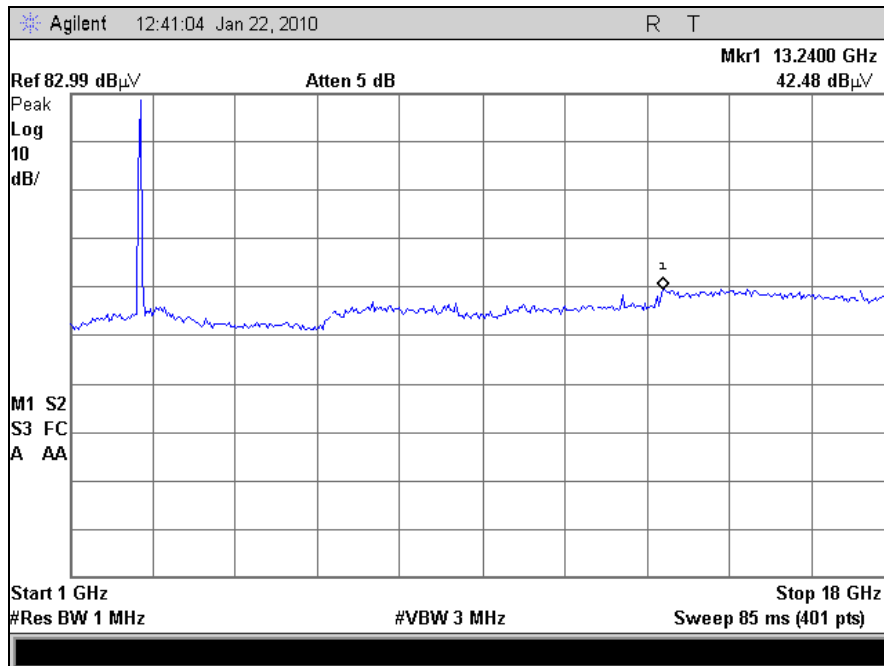


**Plot 40. Radiated Spurious Emissions, 802.11b, Mid Channel**

### Radiated Spurious Emissions Test Results

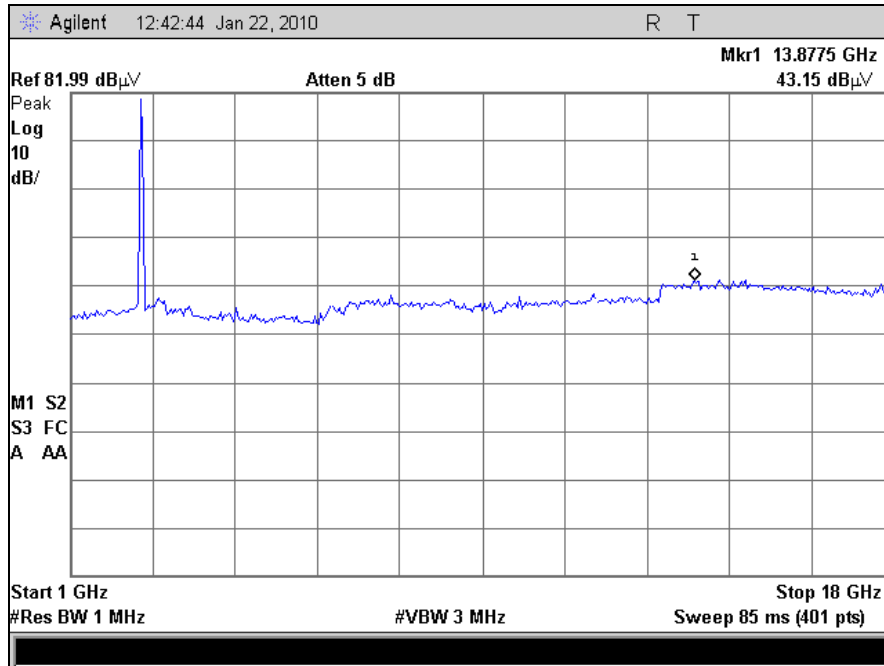


**Plot 41. Radiated Spurious Emissions, 802.11b, High Channel**

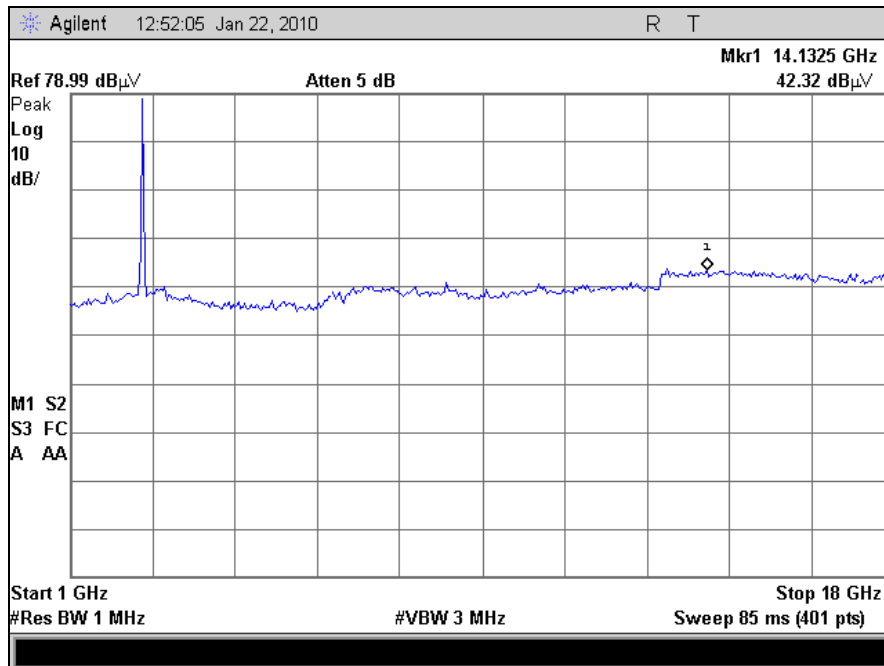


**Plot 42. Radiated Spurious Emissions, 802.11g, Low Channel**

### Radiated Spurious Emissions Test Results



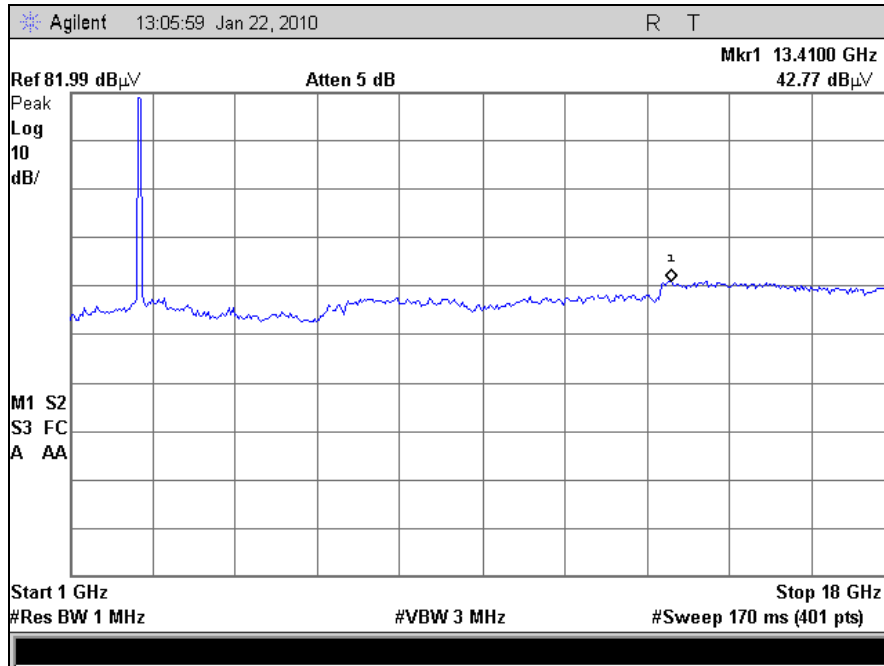
Plot 43. Radiated Spurious Emissions, 802.11g, Mid Channel



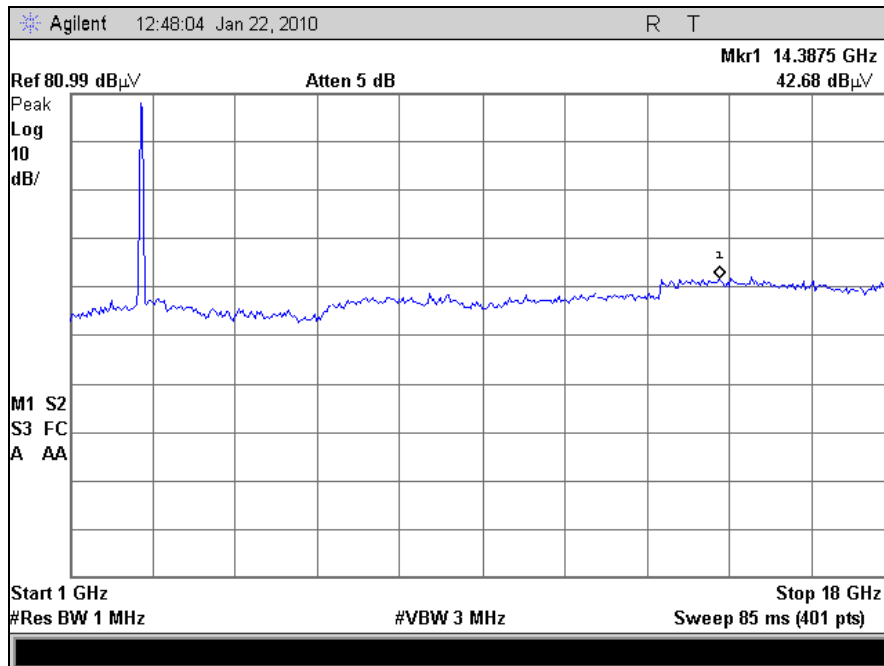
Plot 44. Radiated Spurious Emissions, 802.11g, High Channel



## Radiated Spurious Emissions Test Results

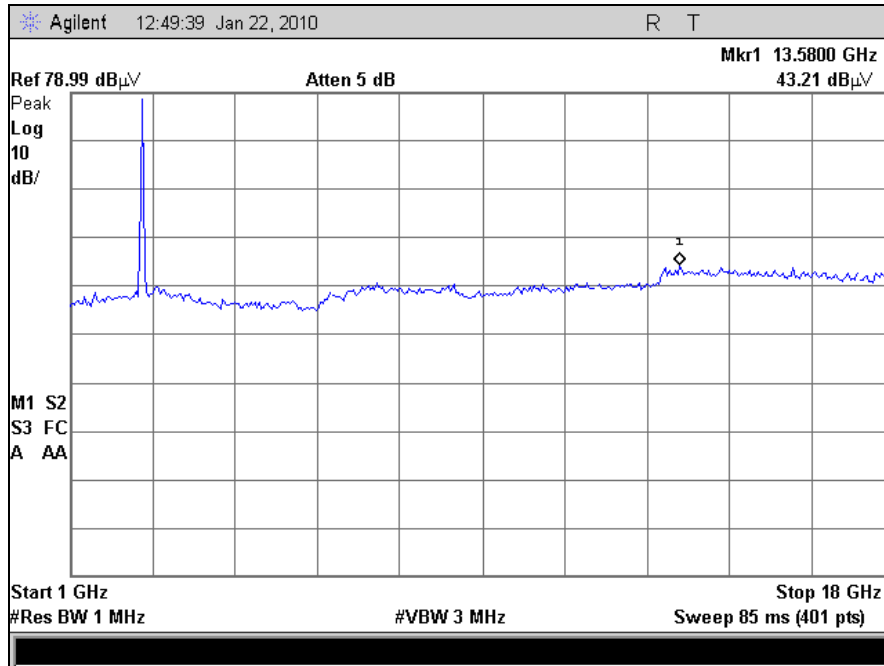


Plot 45. Radiated Spurious Emissions, 802.11n, Low Channel



Plot 46. Radiated Spurious Emissions, 802.11n, Mid Channel

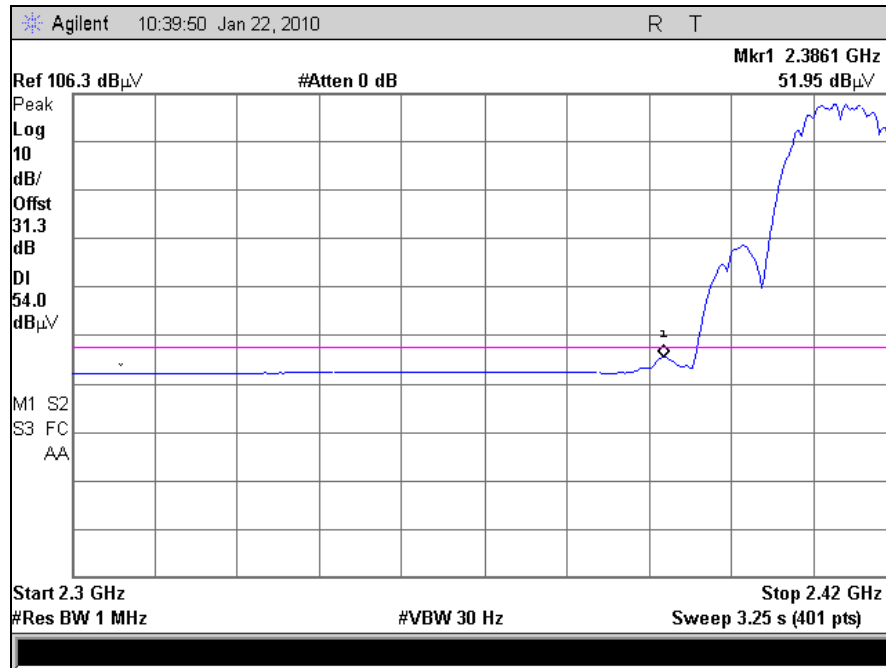
## Radiated Spurious Emissions Test Results



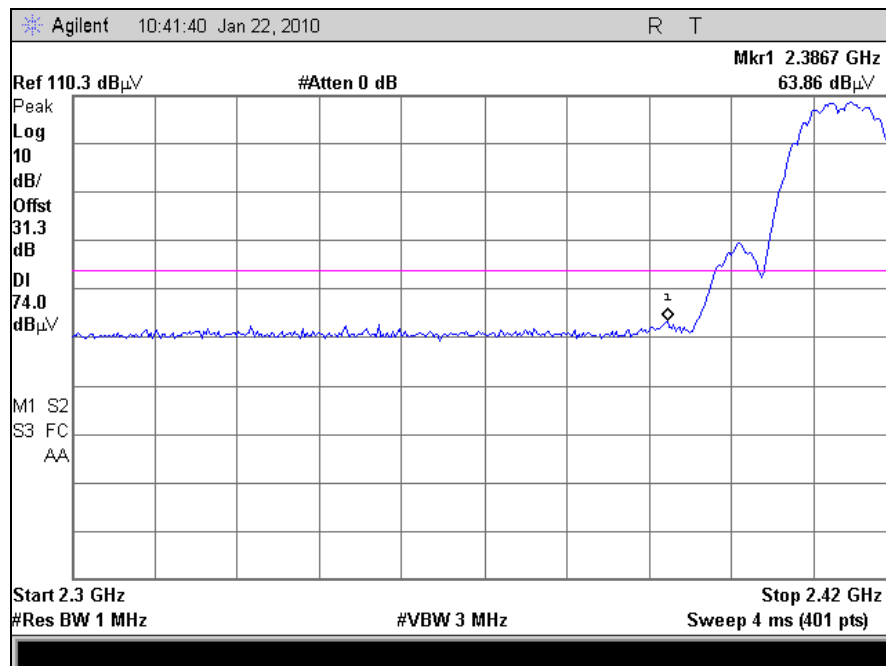
Plot 47. Radiated Spurious Emissions, 802.11n, High Channel

## Radiated Band Edge Measurements

**Test Procedures:** The transmitter was turned. Measurements were performed of the low, mid and high Channels. The EUT was rotated orthogonally through all three axes. Plots shown are corrected for both antenna correction factor and distance and compared to a 3 m limit line.

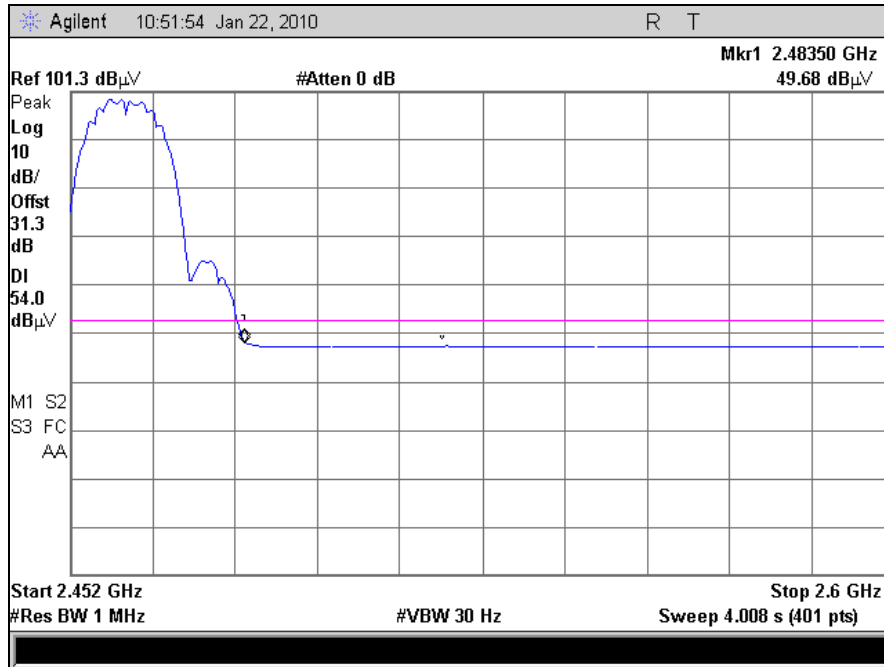


Plot 48. Radiated Band Edge, 802.11b, Channel 1 (Average)

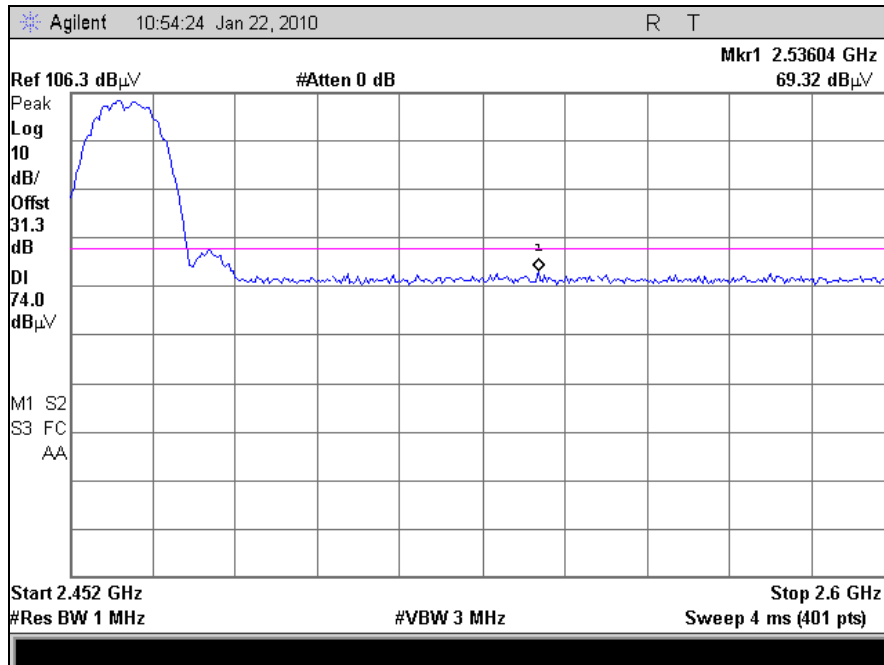


Plot 49. Radiated Band Edge, 802.11b, Channel 1 (Peak)

## Radiated Band Edge Measurements

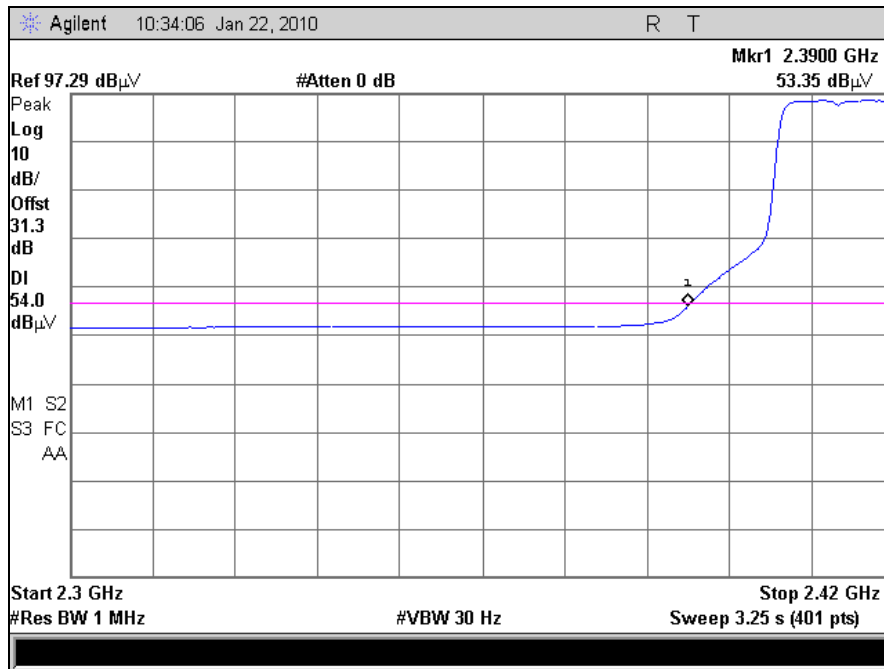


Plot 50. Radiated Band Edge, 802.11b, Channel 11 (Average)

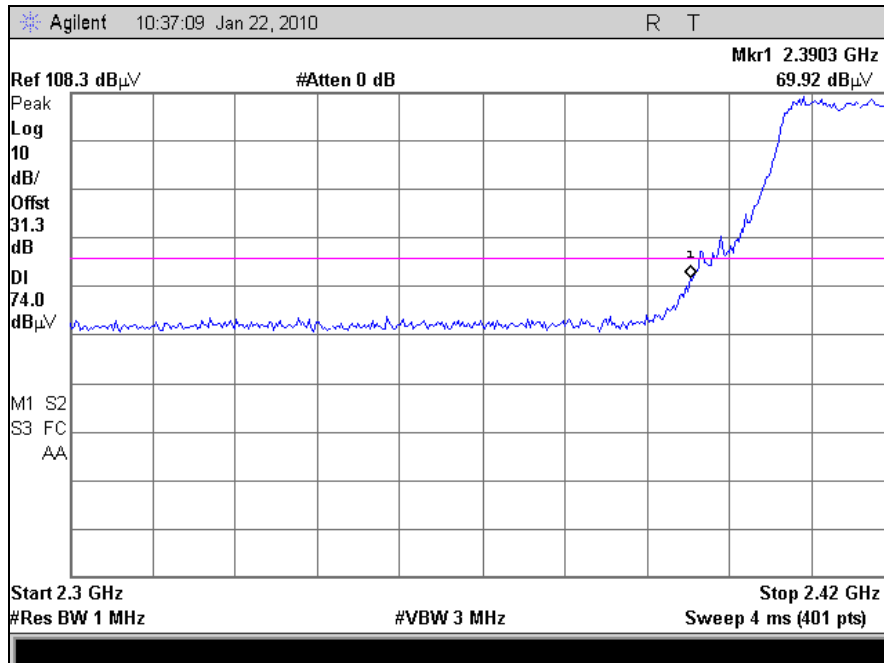


Plot 51. Radiated Band Edge, 802.11b, Channel 11 (Peak)

## Radiated Band Edge Measurements

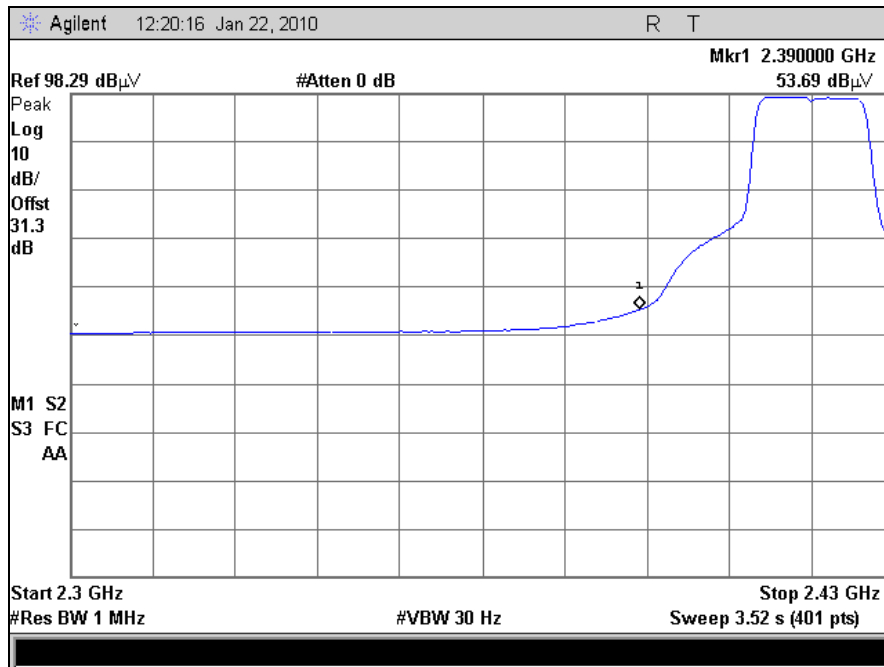


Plot 52. Radiated Band Edge, 802.11g, Channel 1 (Average)

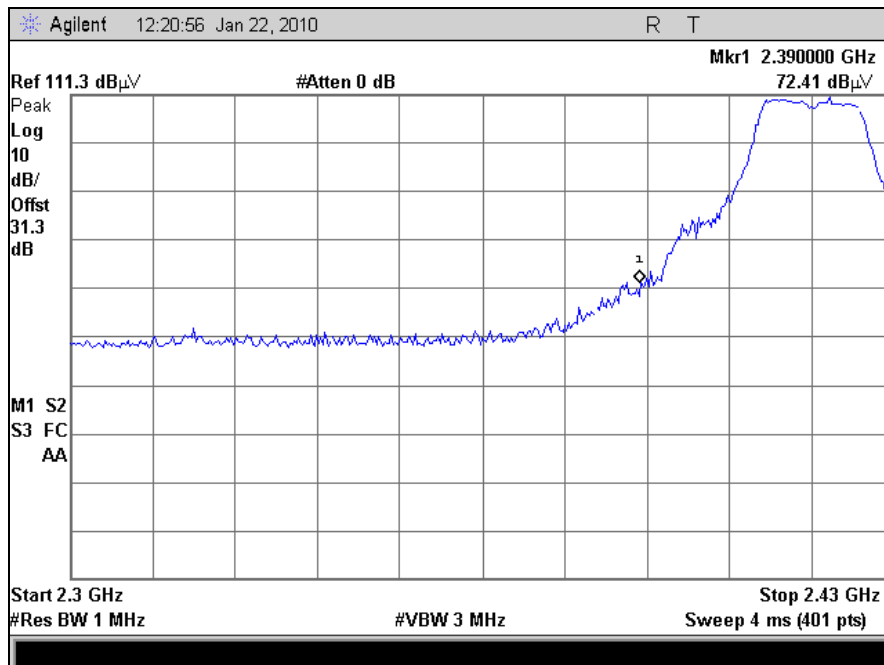


Plot 53. Radiated Band Edge, 802.11g, Channel 1(Peak)

## Radiated Band Edge Measurements

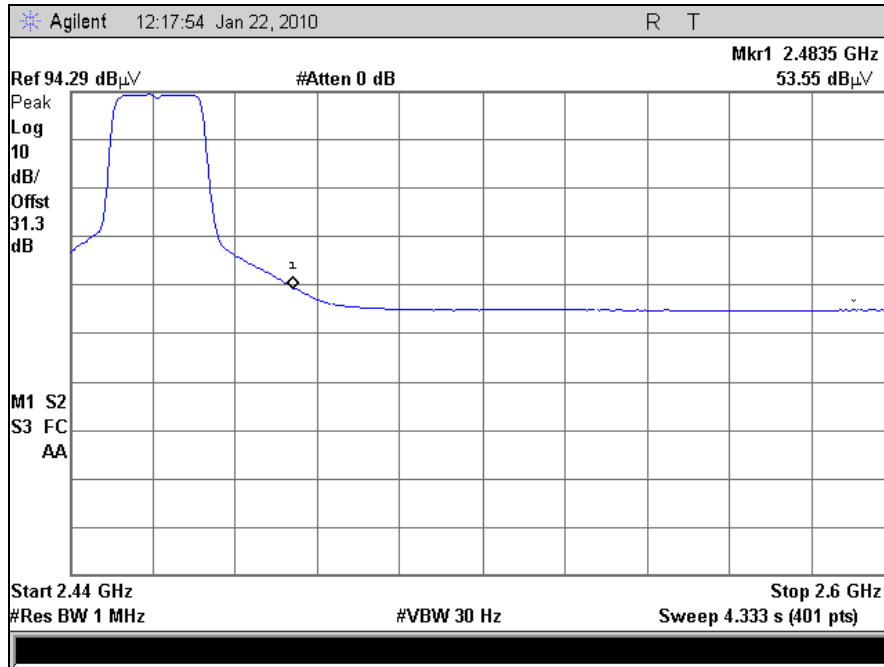


Plot 54. Radiated Band Edge, 802.11g, Channel 2 (Average)

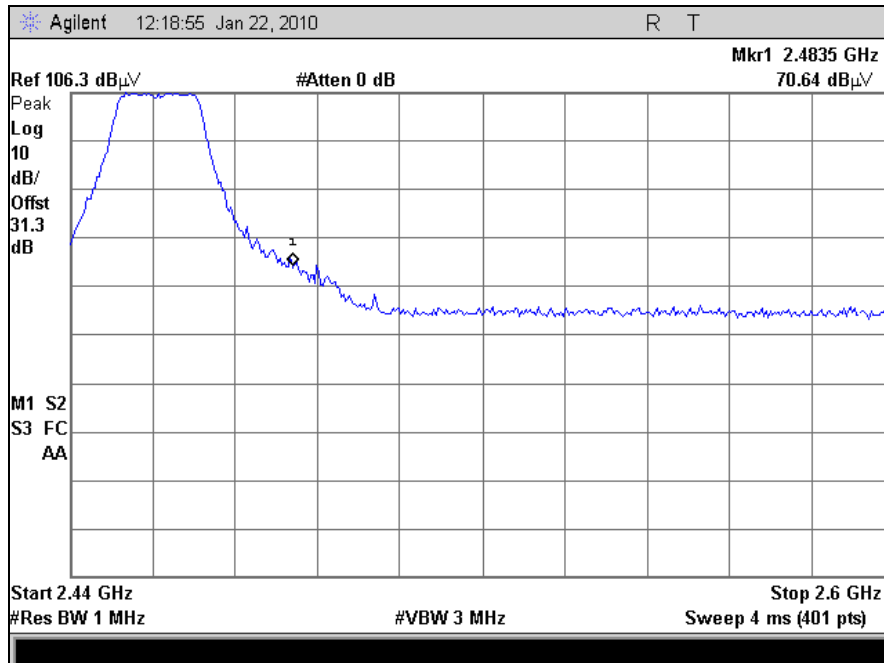


Plot 55. Radiated Band Edge, 802.11g, Channel 2 (Peak)

## Radiated Band Edge Measurements

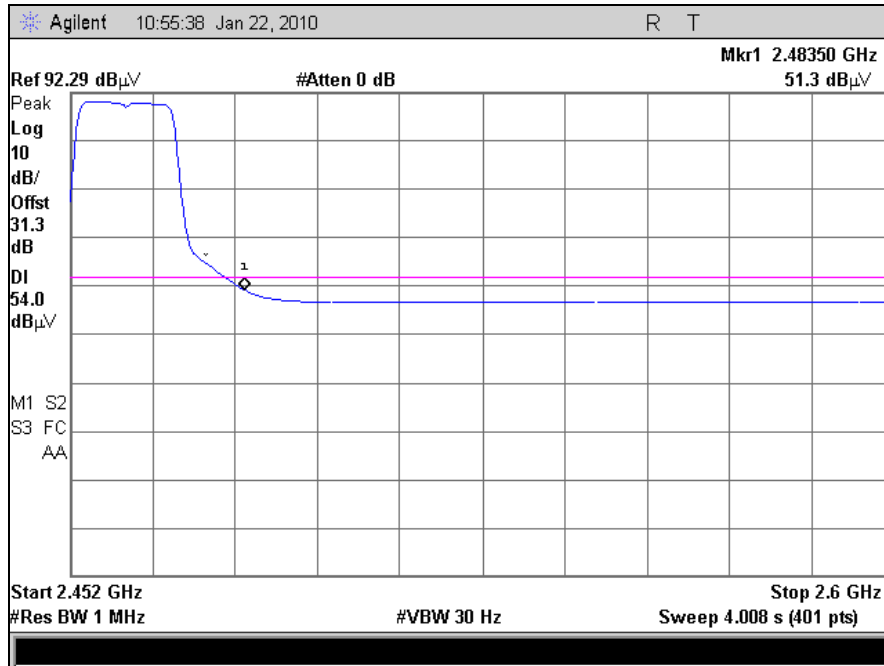


Plot 56. Radiated Band Edge, 802.11g, Channel 10 (Average)

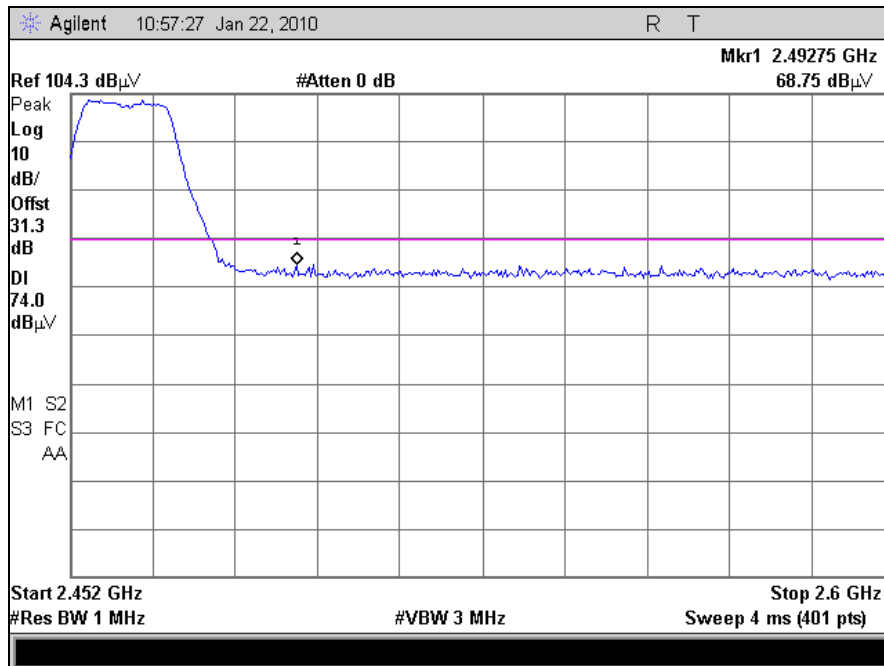


Plot 57. Radiated Band Edge, 802.11g, Channel 10 (Peak)

### Radiated Band Edge Measurements



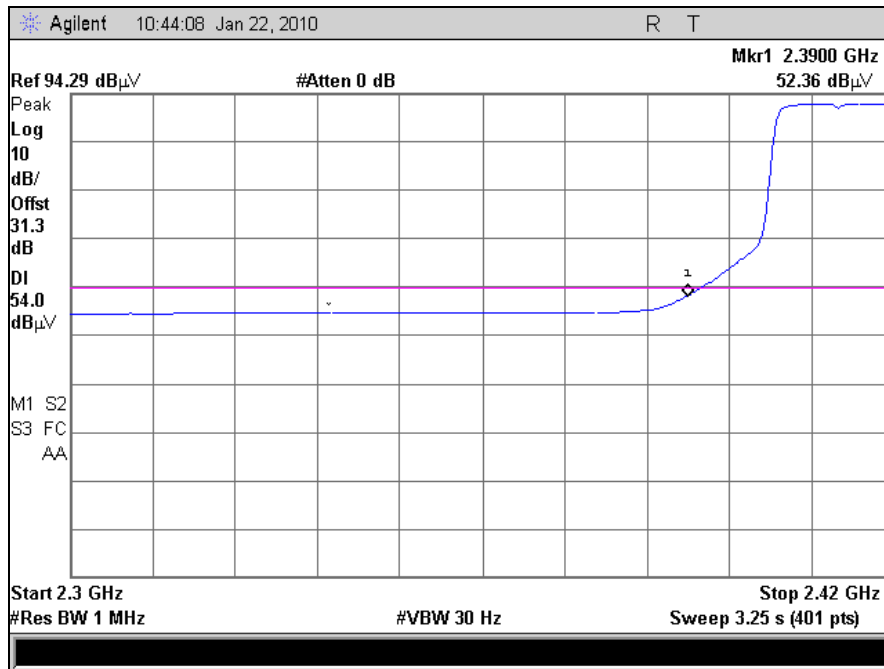
Plot 58. Radiated Band Edge, 802.11g, Channel 11 (Average)



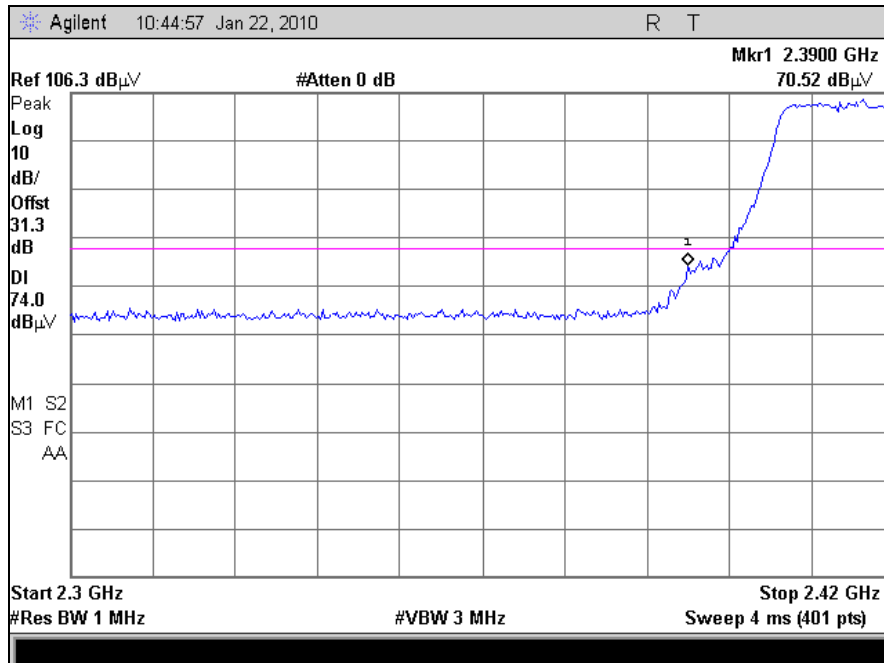
Plot 59. Radiated Band Edge, 802.11g, Channel 11 (Peak)



## Radiated Band Edge Measurements

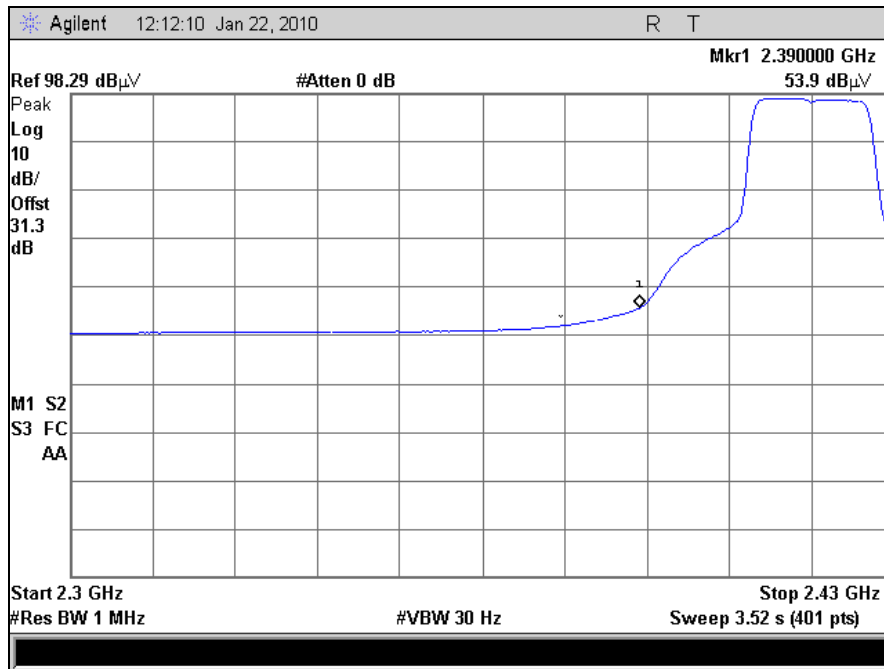


Plot 60. Radiated Band Edge, 802.11n, Channel 1 (Average)

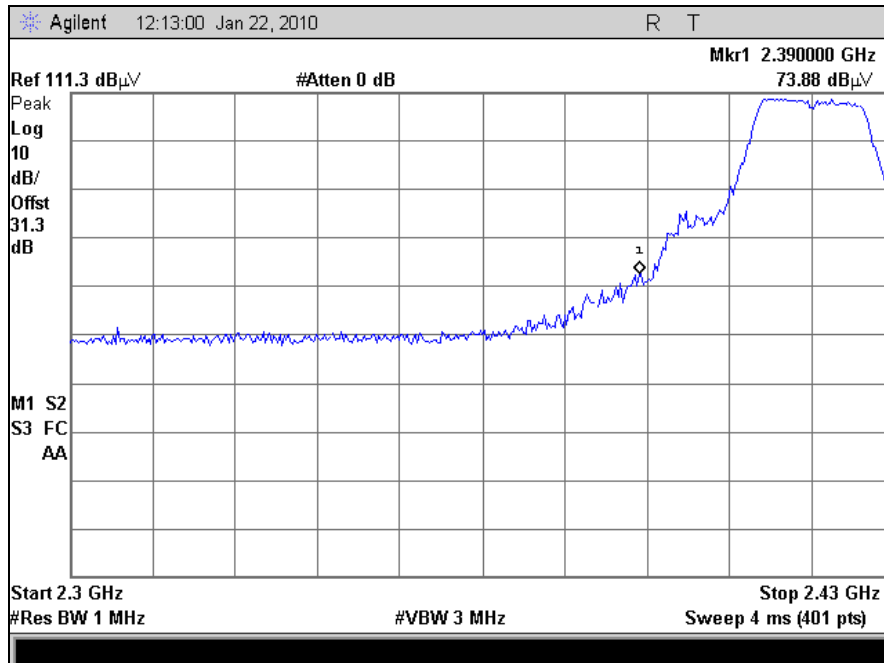


Plot 61. Radiated Band Edge, 802.11n, Channel 1 (Peak)

## Radiated Band Edge Measurements

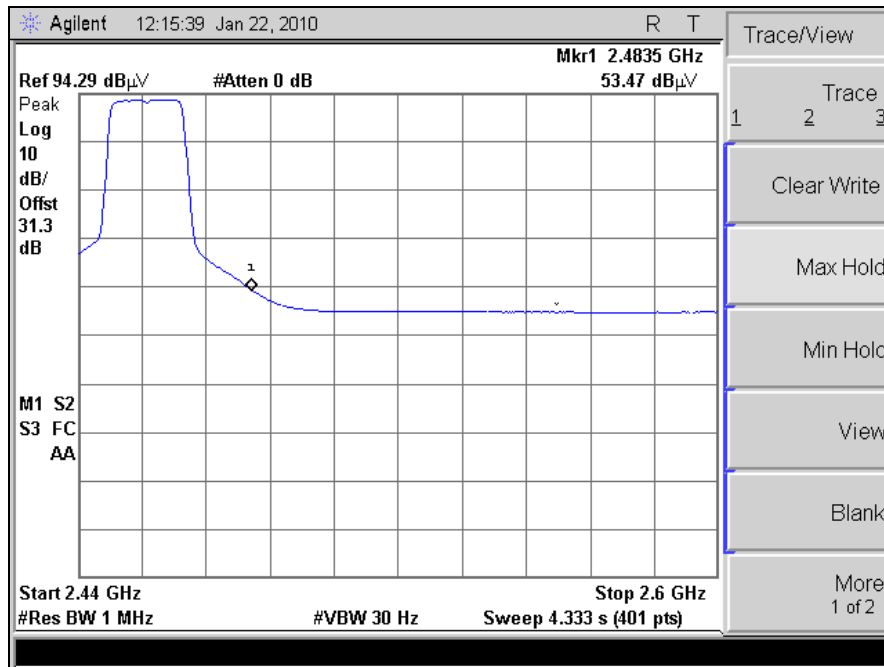


Plot 62. Radiated Band Edge, 802.11n, Channel 2 (Average)

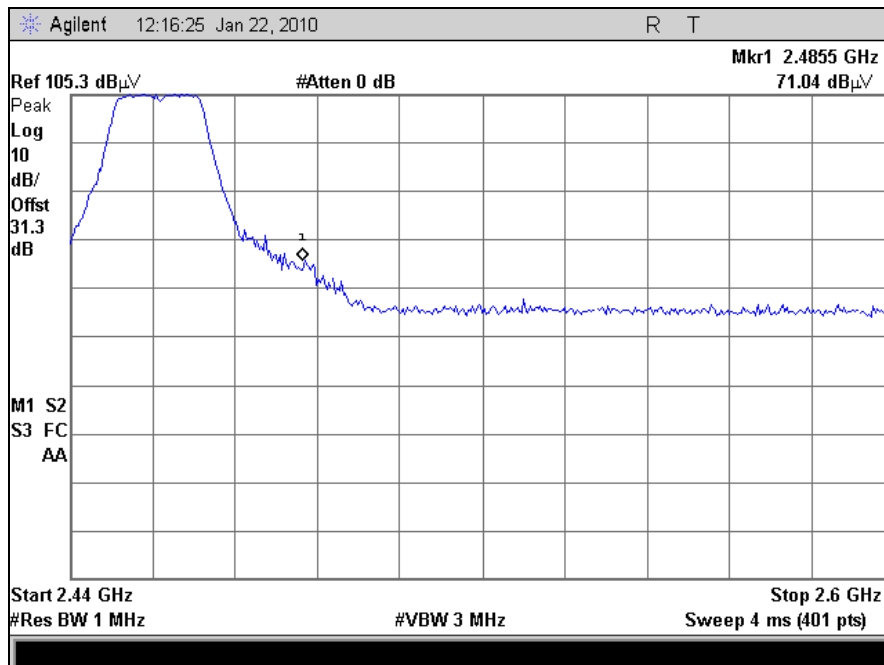


Plot 63. Radiated Band Edge, 802.11n, Channel 2 (Peak)

## Radiated Band Edge Measurements

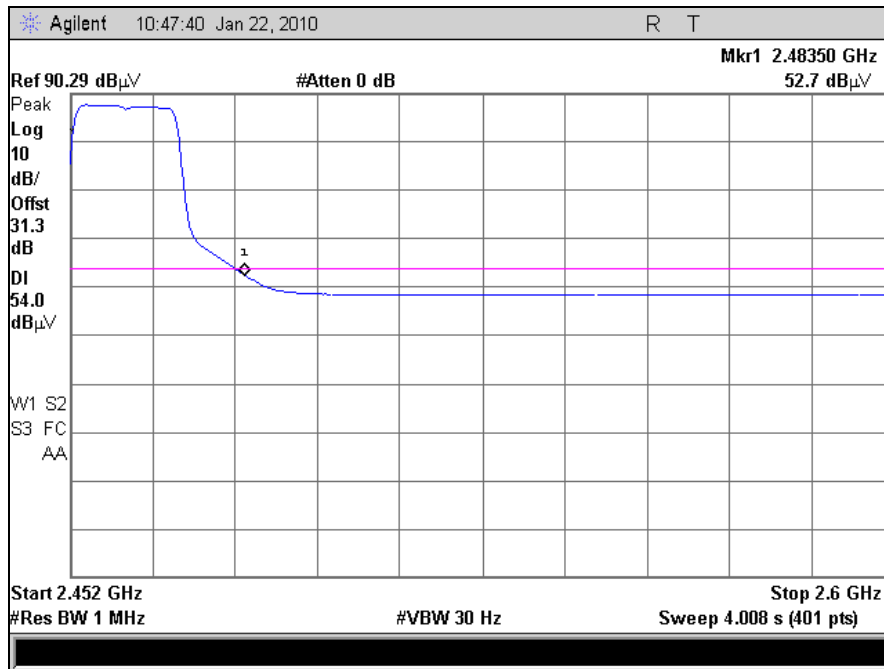


Plot 64. Radiated Band Edge, 802.11n, Channel 10 (Average)

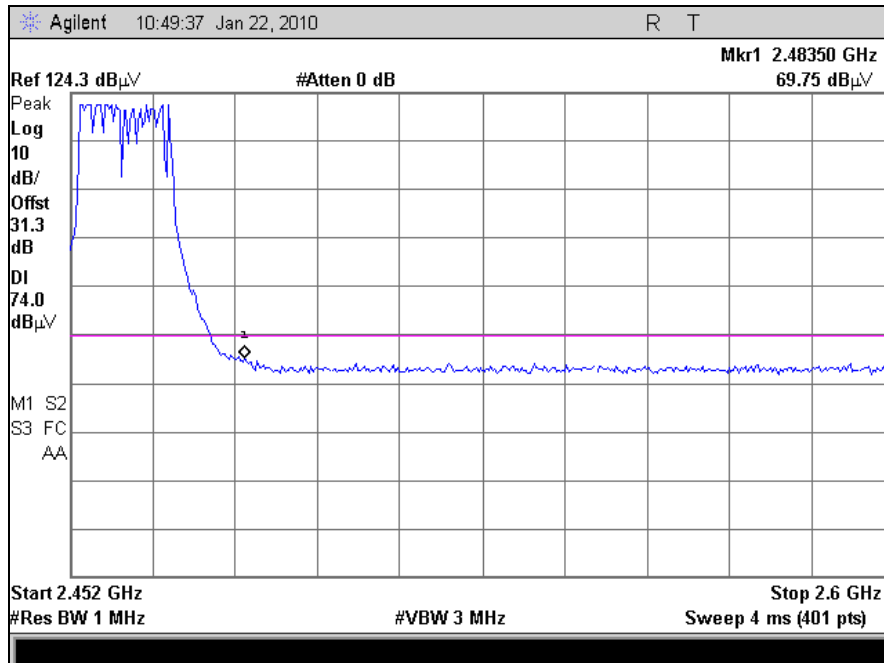


Plot 65. Radiated Band Edge, 802.11n, Channel 10 (Peak)

## Radiated Band Edge Measurements

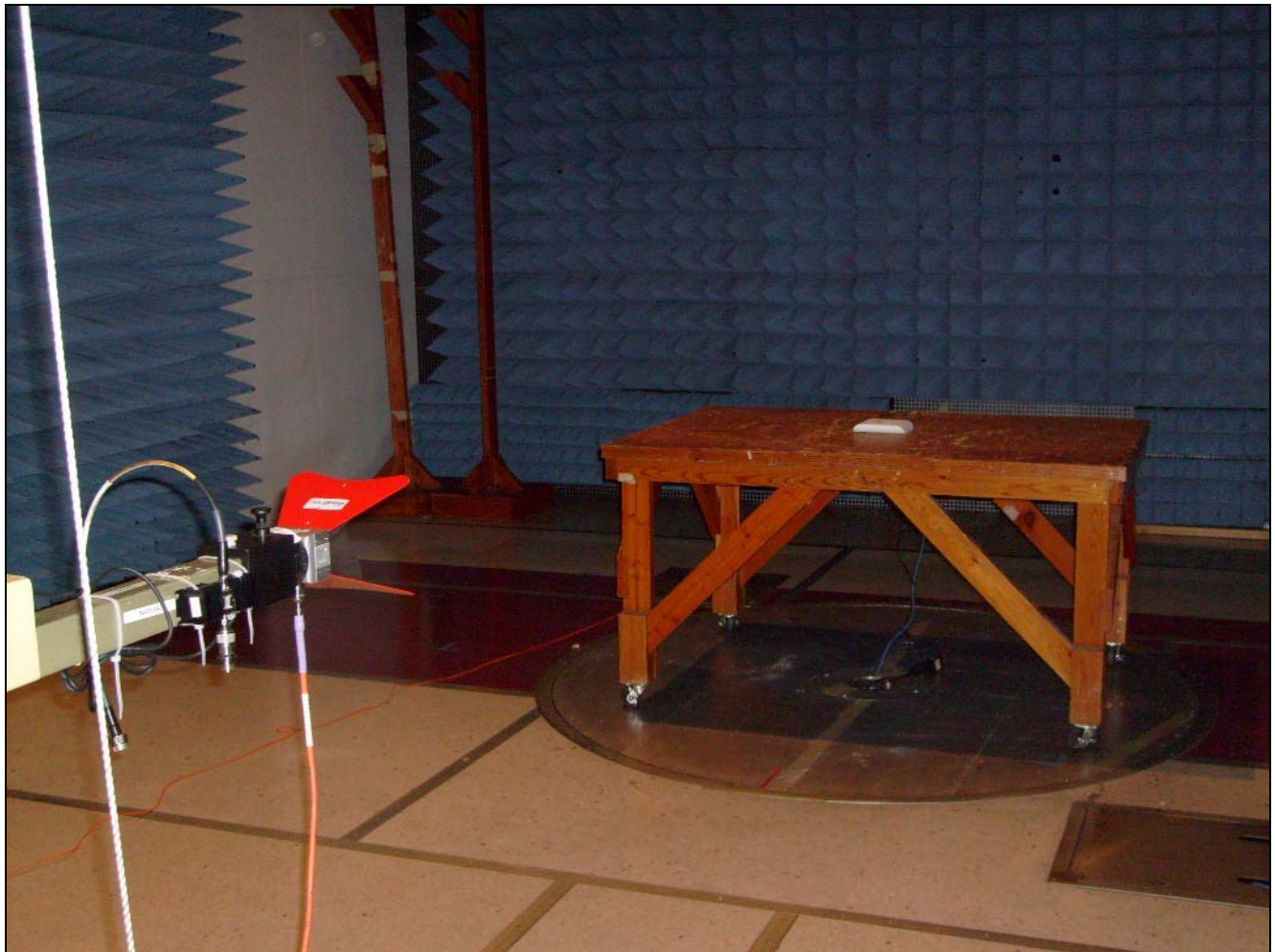


Plot 66. Radiated Band Edge, 802.11n, Channel 11 (Average)



Plot 67. Radiated Band Edge, 802.11n, Channel 11 (Peak)

## Radiated Spurious Emissions Test Setup Photographs



**Photograph 7. Radiated Spurious Emissions, Test Setup**

## Electromagnetic Compatibility Criteria for Intentional Radiators

### RSS-GEN Receiver Spurious Emissions Requirements

**Test Requirements:** The following receiver spurious emission limits shall be complied with:

- (a) If a radiated measurement is made, all spurious emissions shall comply with the limits of Table 35.

Spurious Frequency (MHz)	Field Strength (microvolt/m at 3 metres)
30 – 88	100
88 – 216	150
216 – 960	200
Above 960	500

**Table 35. Spurious Emission Limits for Receivers**

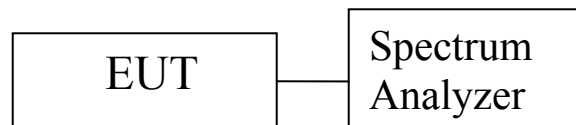
- (b) If a conducted measurement is made, no spurious output signals appearing at the antenna terminals shall exceed 2 nanowatts per any 4 kHz spurious frequency in the band 30-1000 MHz, or 5 nanowatts above 1 GHz.

**Test Procedures:** The EUT was programmed for receive mode only. Conducted measurements were taken at the antenna port of the EUT. 100 kHz resolution bandwidth was used from 30 MHz - 1 GHz and 300 kHz resolution was used for measurements done above 1 GHz. All plots are corrected for cable loss.

**Test Results:** Equipment complies with the Receiver Spurious Emissions Requirements of RSS-GEN.

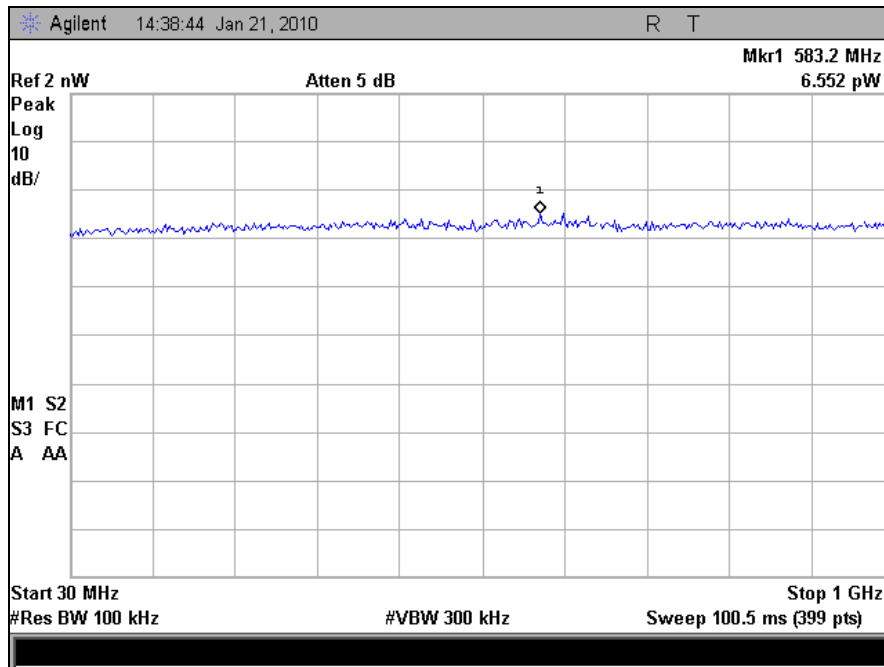
**Test Engineer(s):** Anderson Soungpanya

**Test Date(s):** 01/22/10

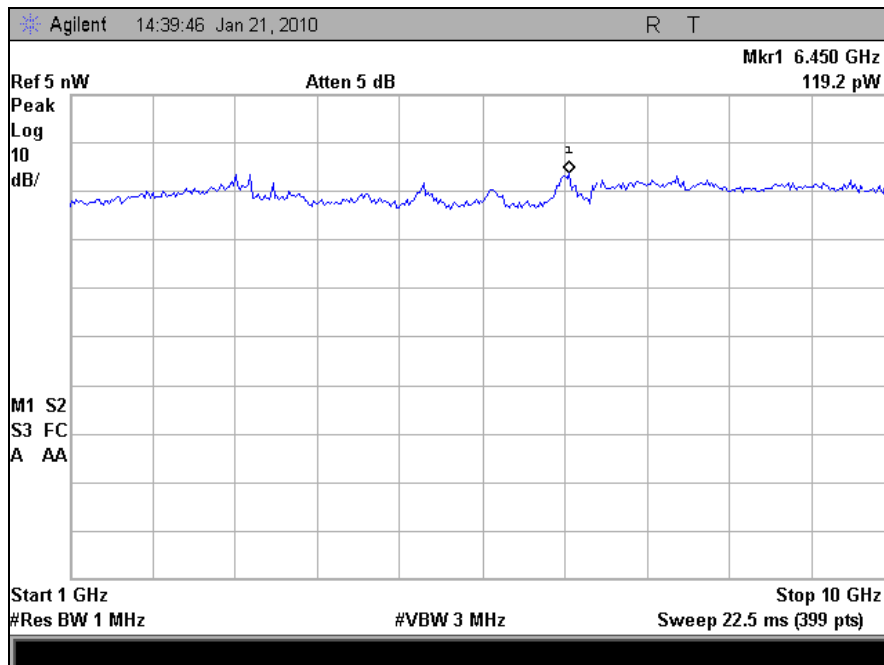


**Figure 4. Block Diagram, Conducted Receiver Spurious Emissions, Test Setup**

## Conducted Receiver Spurious Emissions



Plot 68. Receiver Spurious Emission, 30 MHz – 1 GHz, Horizontal



Plot 69. Receiver Spurious Emission, 1 GHz – 10 GHz, Vertical

## Electromagnetic Compatibility Criteria for Intentional Radiators

### § 15.247(d) RF Conducted Spurious Emissions Requirements and Band Edge

**Test Requirement:** **15.247(d)** In any 100 kHz bandwidth outside the frequency band in which the spread spectrum or digitally modulated intentional radiator is operating, the radio frequency power that is produced by the intentional radiator shall be at least 20 dB below that in the 100 kHz bandwidth within the band that contains the highest level of the desired power, based on either an RF conducted or a radiated measurement, provided the transmitter demonstrates compliance with the peak conducted power limits. If the transmitter complies with the conducted power limits based on the use of RMS averaging over a time interval, as permitted under paragraph (b)(3) of this section, the attenuation required under this paragraph shall be 30 dB instead of 20 dB.

**Test Procedure:** For intentional radiators with a digital device portion which operates below 10 GHz, the spectrum was investigated as per §15.33(a)(1) and §15.33(a)(4); i.e., the lowest RF signal generated or used in the device up to the 10<sup>th</sup> harmonic of the highest fundamental frequency or to 40 GHz, whichever is lower.

Since the EUT had an integral antenna, conducted measurements could not be performed. Measurements needed to be taken radiated. An antenna was located 3 m away from the EUT and plots were taken. The EUT was rotated through all three orthogonal axes. The plots were corrected for both antenna correction factor and cable loss.

See following pages for detailed test results with RF Conducted Spurious Emissions.

**Test Results:** The EUT was compliant with the Conducted Spurious Emission limits of §15.247(d). Measured emissions were below applicable limits.

**Test Engineer(s):** Anderson Soungpanya

**Test Date(s):** 01/22/10

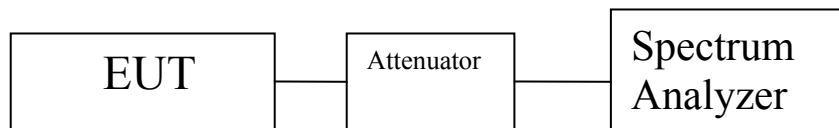
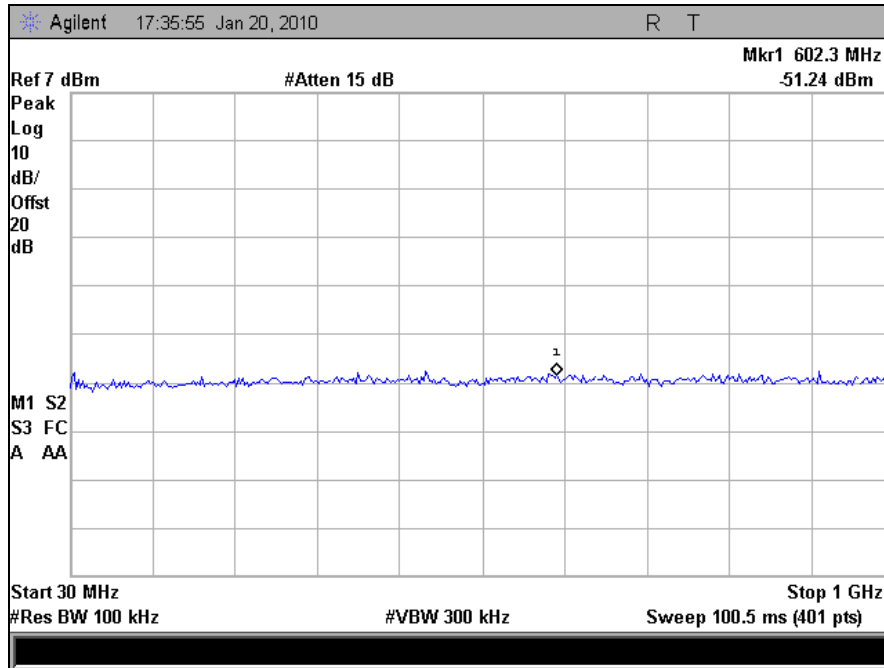


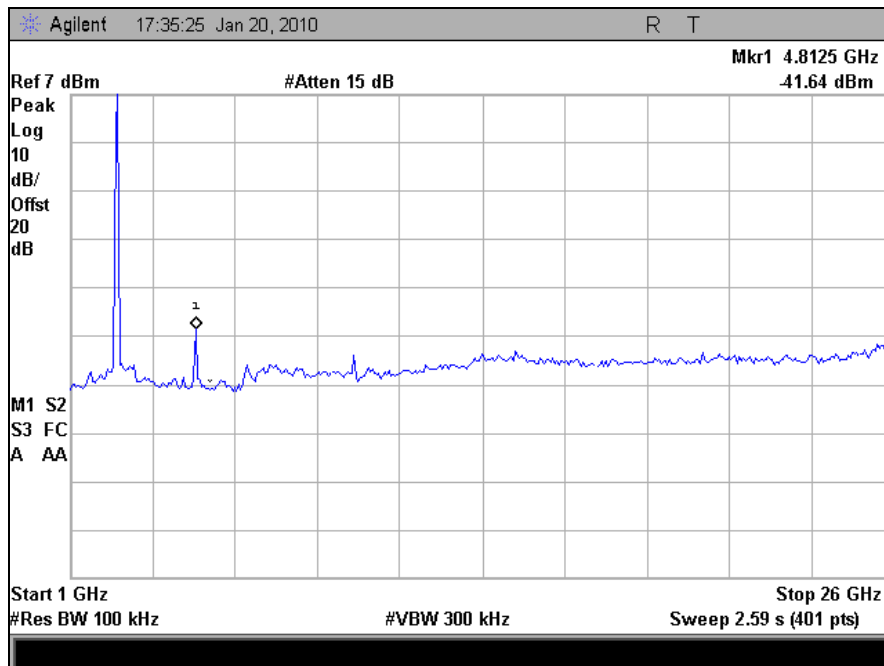
Figure 5. Block Diagram, Conducted Spurious Emissions, Test Setup



## Conducted Spurious Emissions Test Results

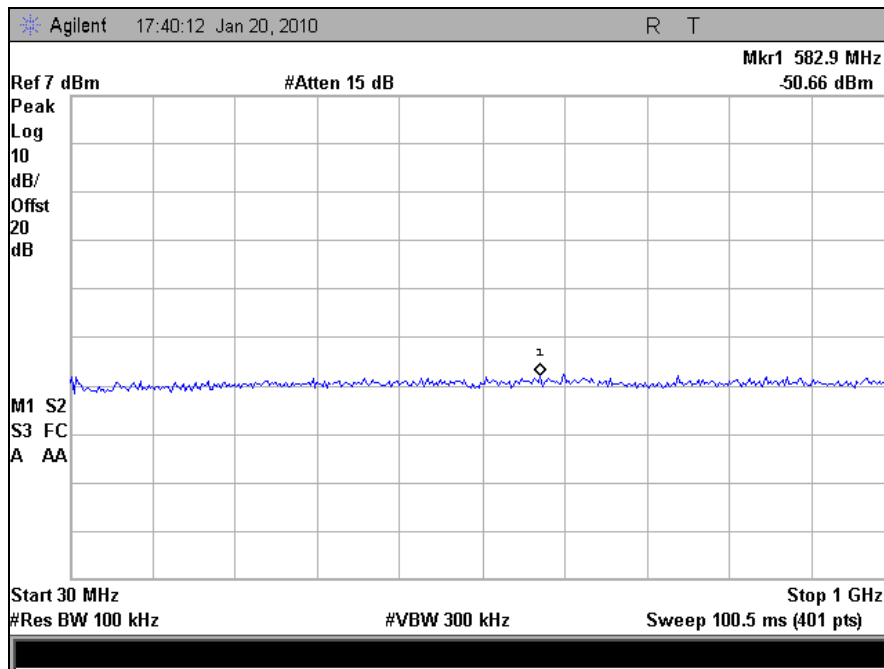


Plot 70. Conducted Spurious, Low Channel, 802.11b (30 MHz - 1 GHz)

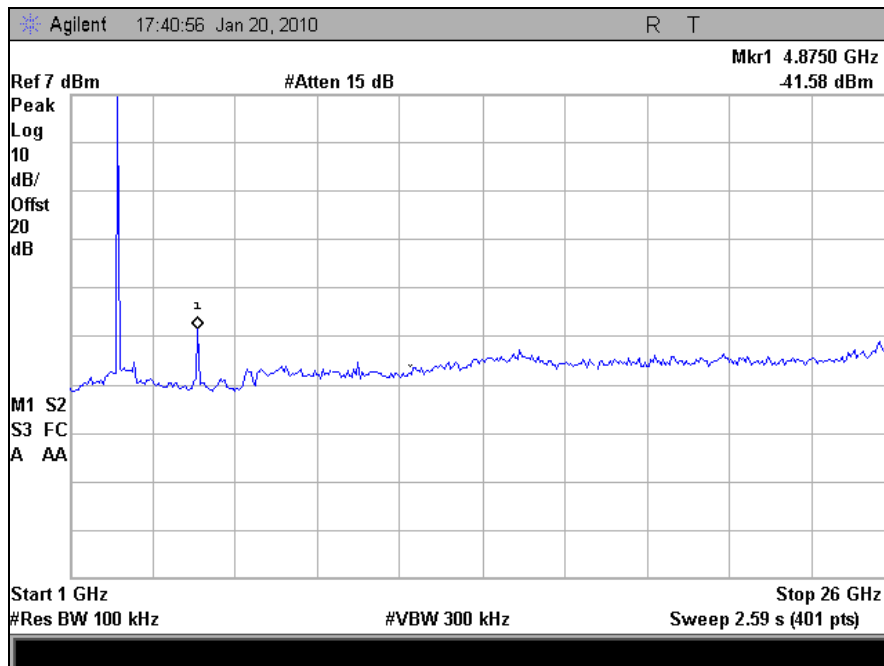


Plot 71. Conducted Spurious, Low Channel, 802.11b (1 GHz - 26 GHz)

## Conducted Spurious Emissions Test Results

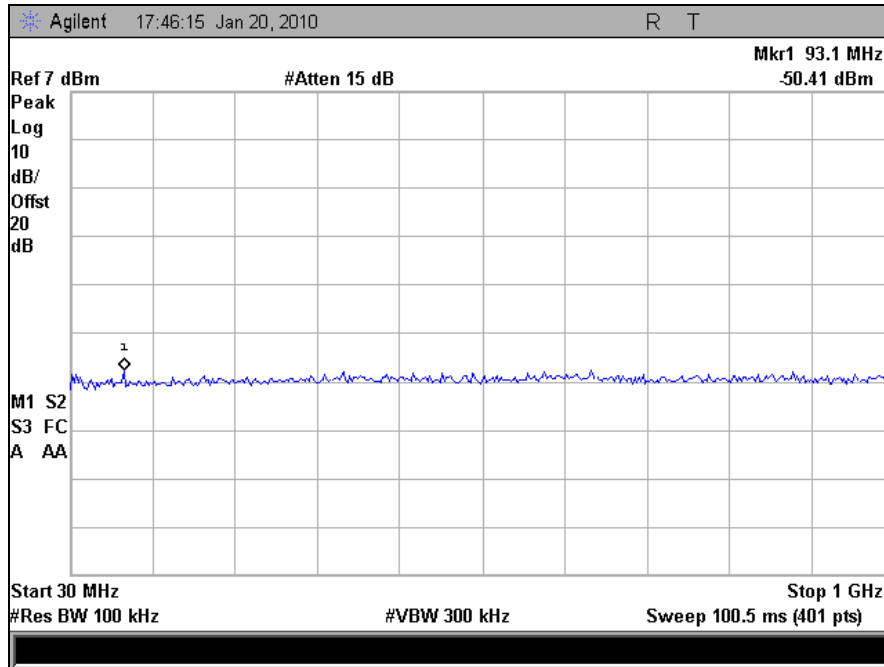


Plot 72. Conducted Spurious, Mid Channel, 802.11b (30 MHz - 1 GHz)

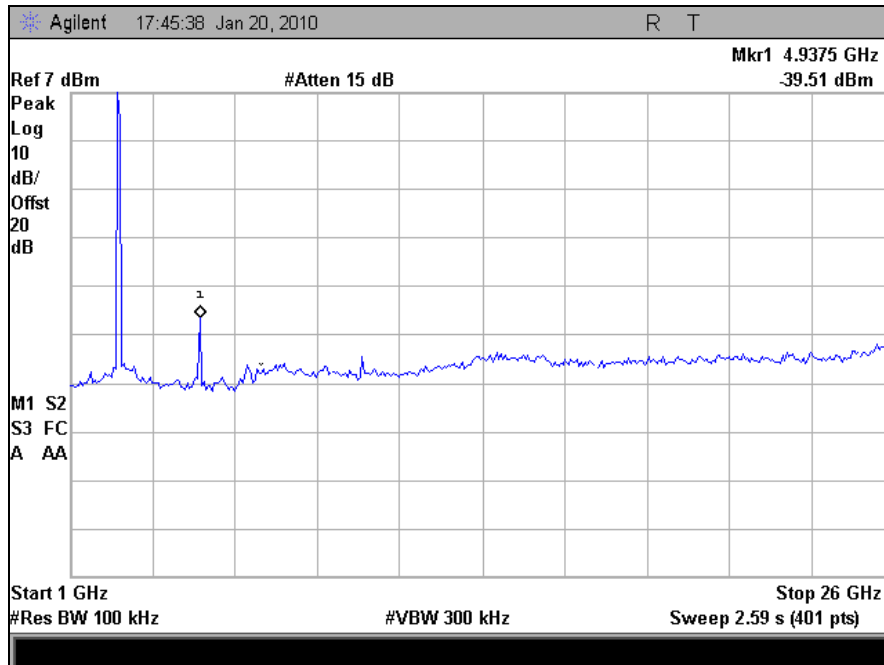


Plot 73. Conducted Spurious, Mid Channel, 802.11b (1 GHz - 26 GHz)

## Conducted Spurious Emissions Test Results

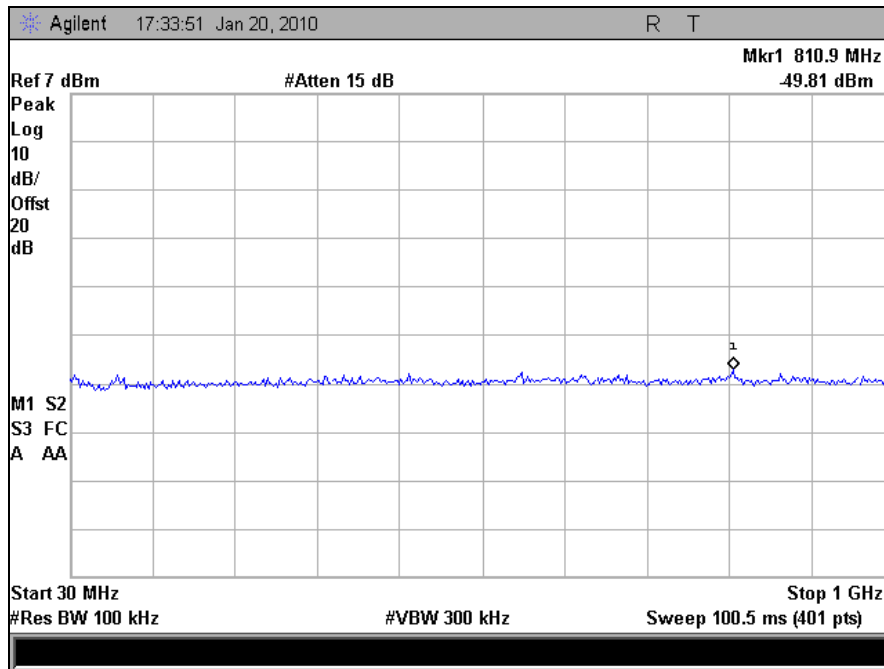


Plot 74. Conducted Spurious, High Channel, 802.11b (30 MHz - 1 GHz)

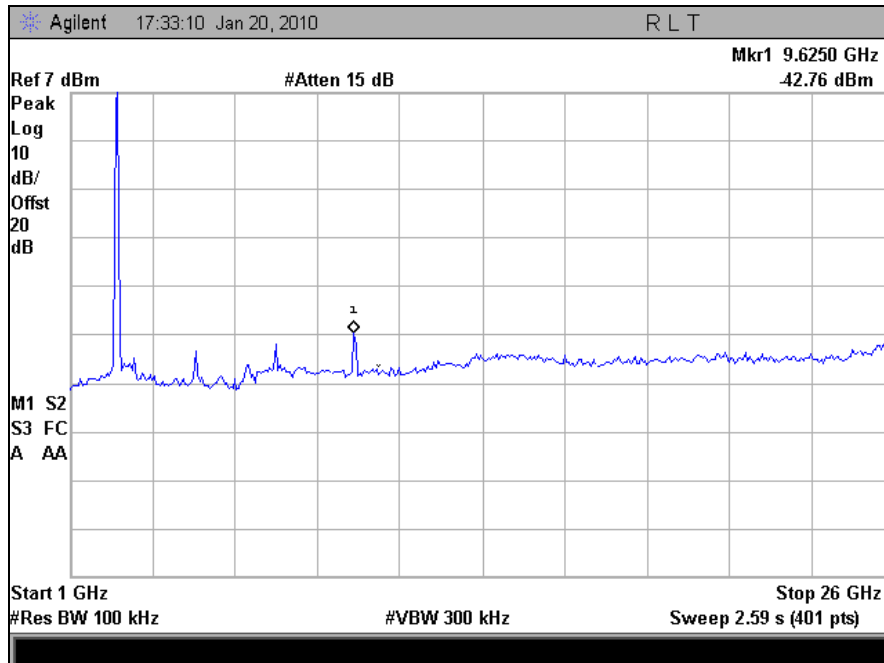


Plot 75. Conducted Spurious, High Channel, 802.11b (1 GHz - 26 GHz)

## Conducted Spurious Emissions Test Results

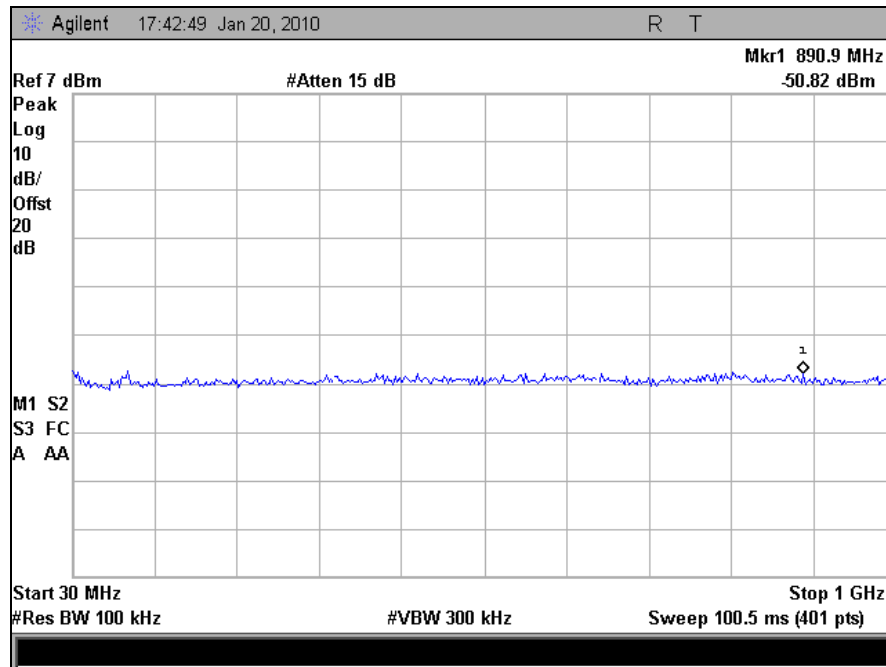


Plot 76. Conducted Spurious, Low Channel, 802.11g (30 MHz - 1 GHz)

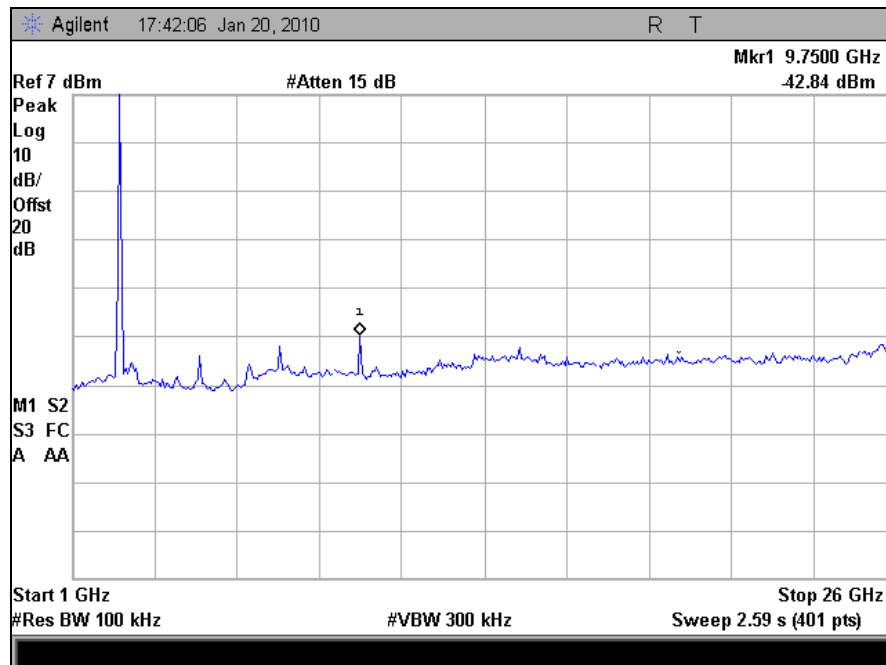


Plot 77. Conducted Spurious, Low Channel, 802.11g (1 GHz - 26 GHz)

## Conducted Spurious Emissions Test Results

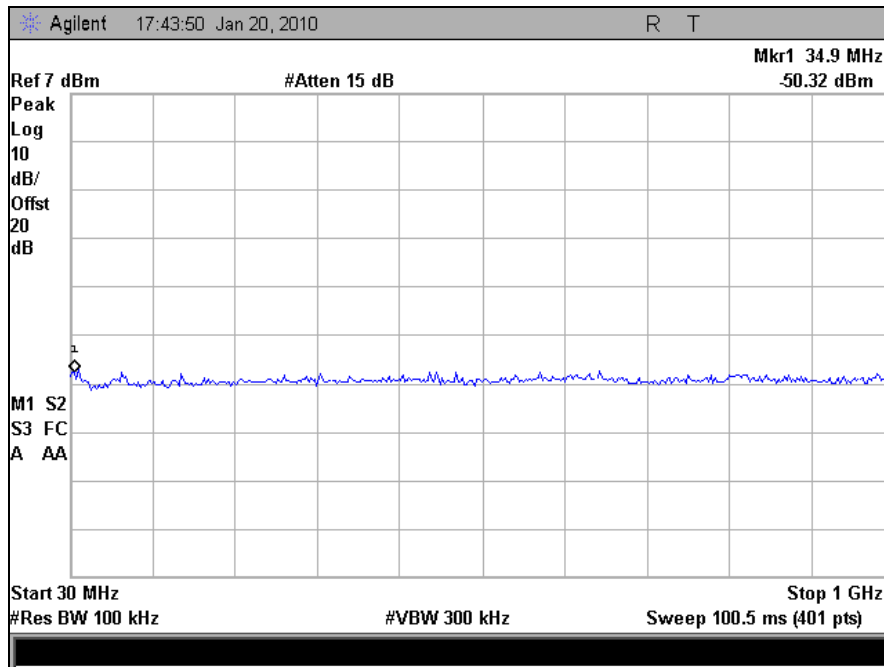


**Plot 78. Conducted Spurious, Mid Channel, 802.11g (30 MHz - 1 GHz)**

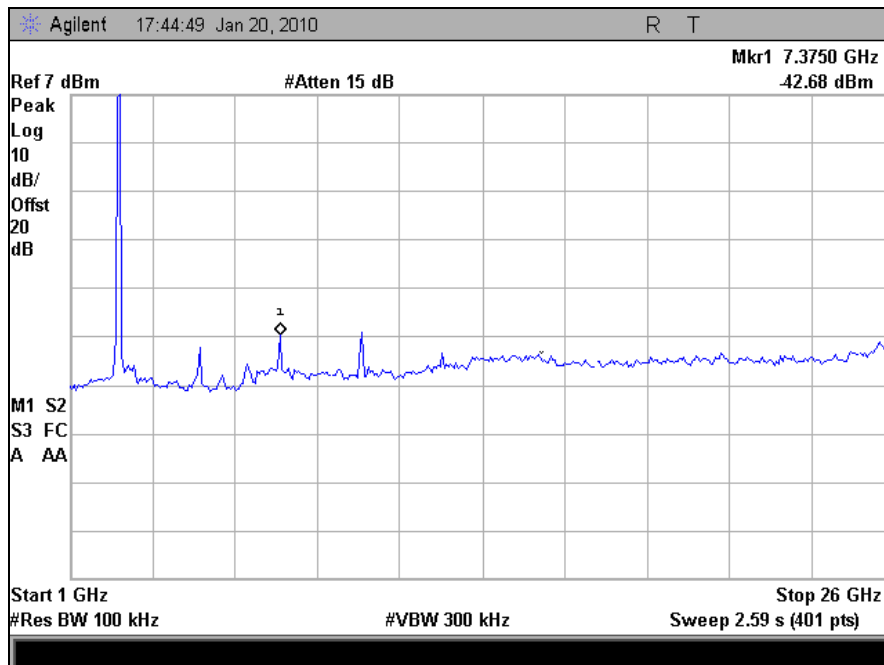


**Plot 79. Conducted Spurious, Mid Channel, 802.11g (1 GHz - 26 GHz)**

## Conducted Spurious Emissions Test Results

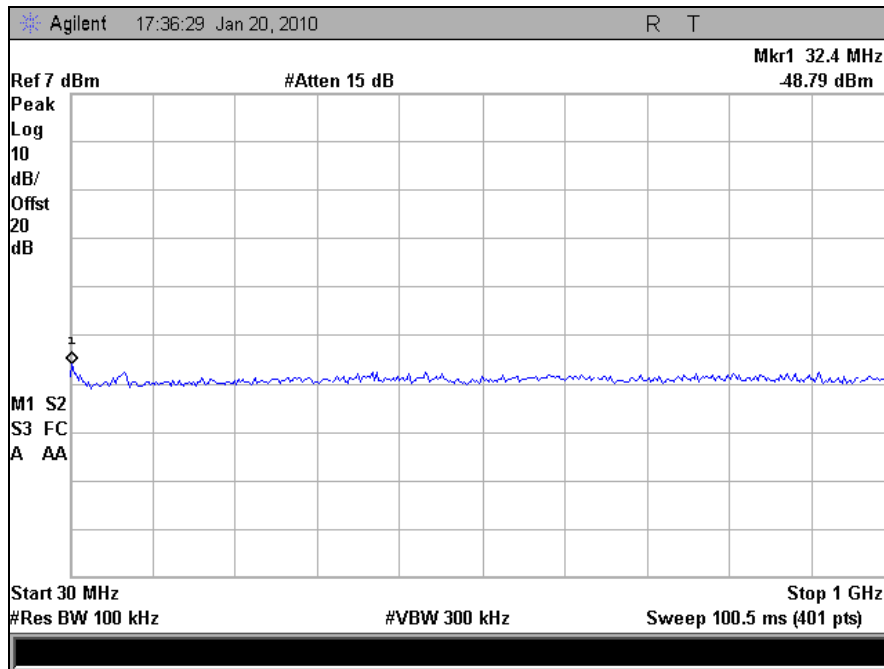


**Plot 80. Conducted Spurious, High Channel, 802.11g (30 MHz - 1 GHz)**

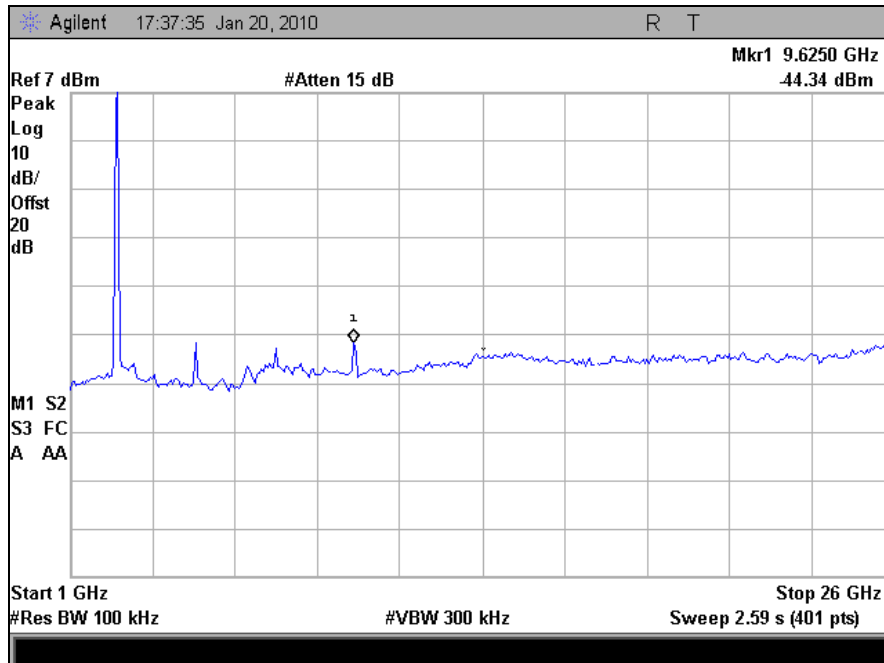


**Plot 81. Conducted Spurious, High Channel, 802.11g (1 GHz - 26 GHz)**

## Conducted Spurious Emissions Test Results

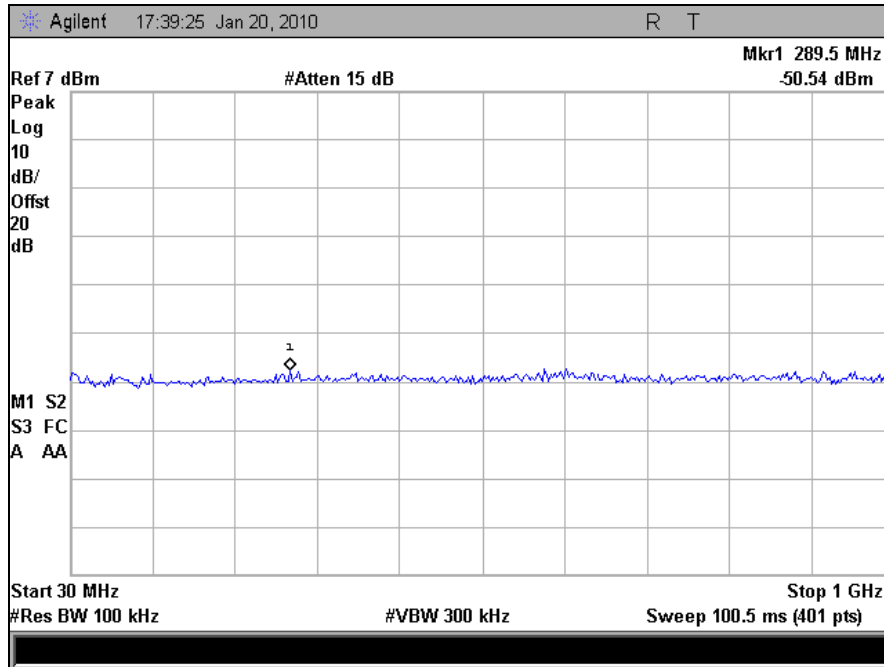


**Plot 82. Conducted Spurious, Low Channel, 802.11n (30 MHz - 1 GHz)**

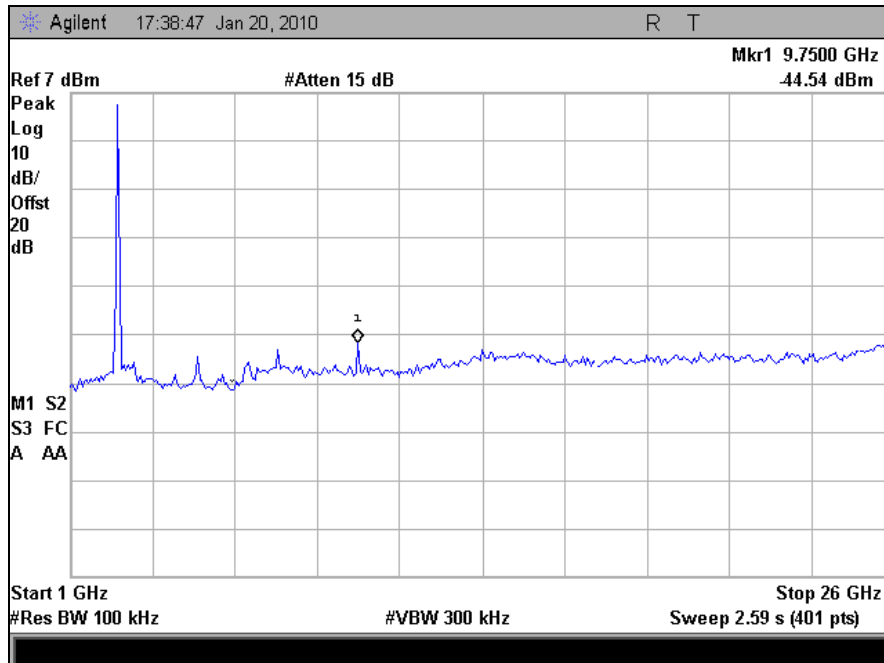


**Plot 83. Conducted Spurious, Low Channel, 802.11n (1 GHz - 26 GHz)**

## Conducted Spurious Emissions Test Results



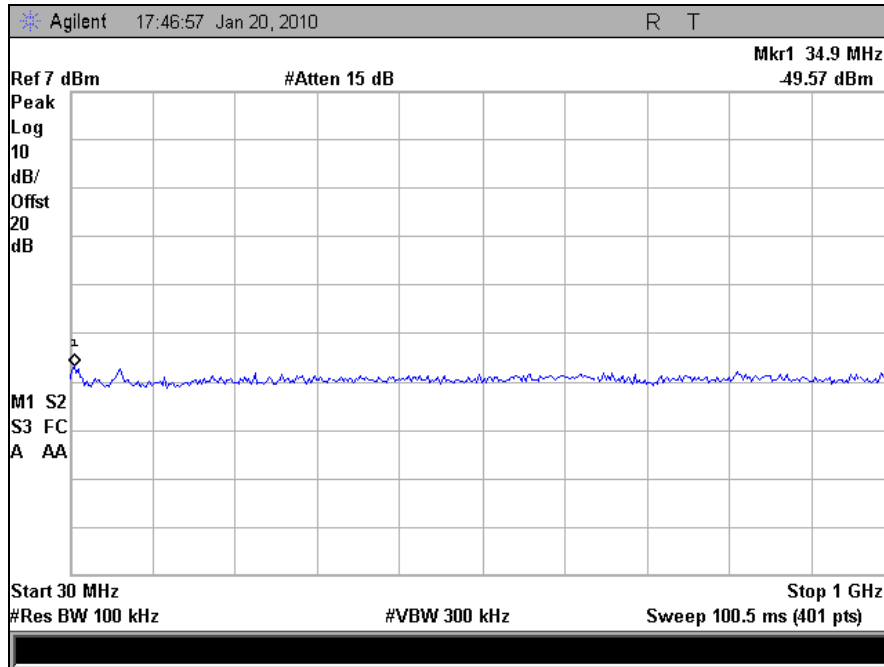
**Plot 84. Conducted Spurious, Mid Channel, 802.11n (30 MHz - 1 GHz)**



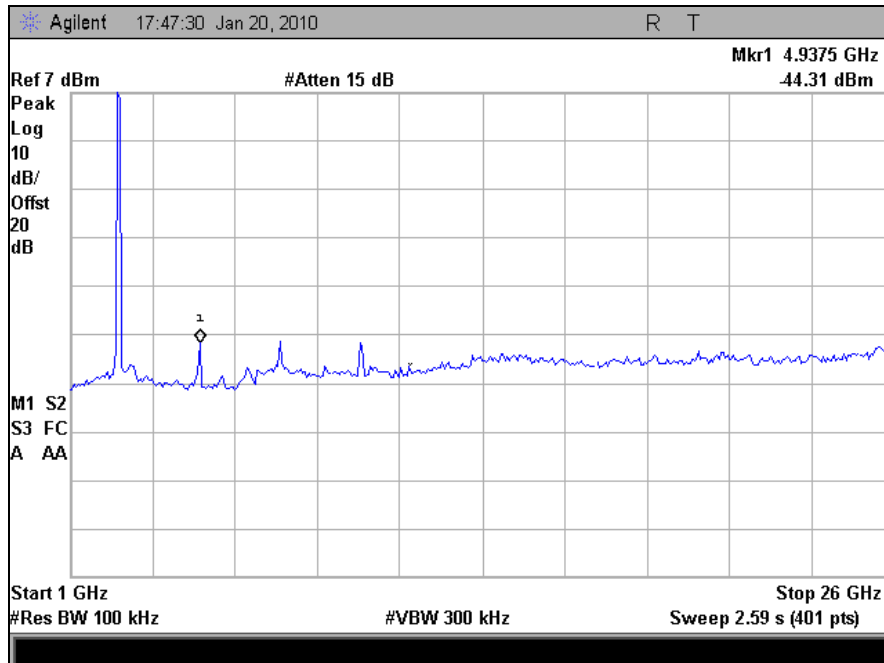
**Plot 85. Conducted Spurious, Mid Channel, 802.11n (1 GHz - 26 GHz)**



## Conducted Spurious Emissions Test Results

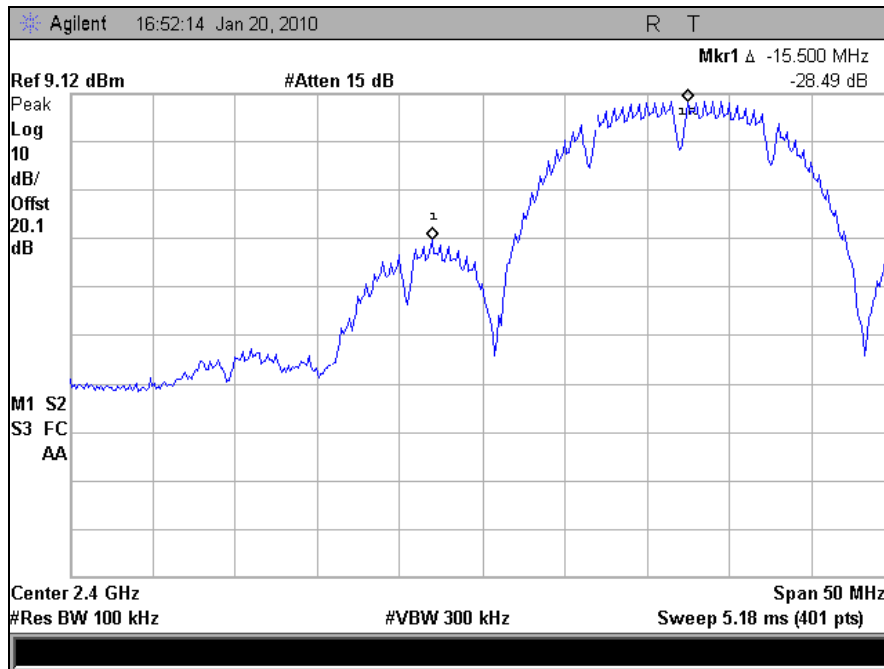


**Plot 86. Conducted Spurious, High Channel, 802.11n (30 MHz - 1 GHz)**

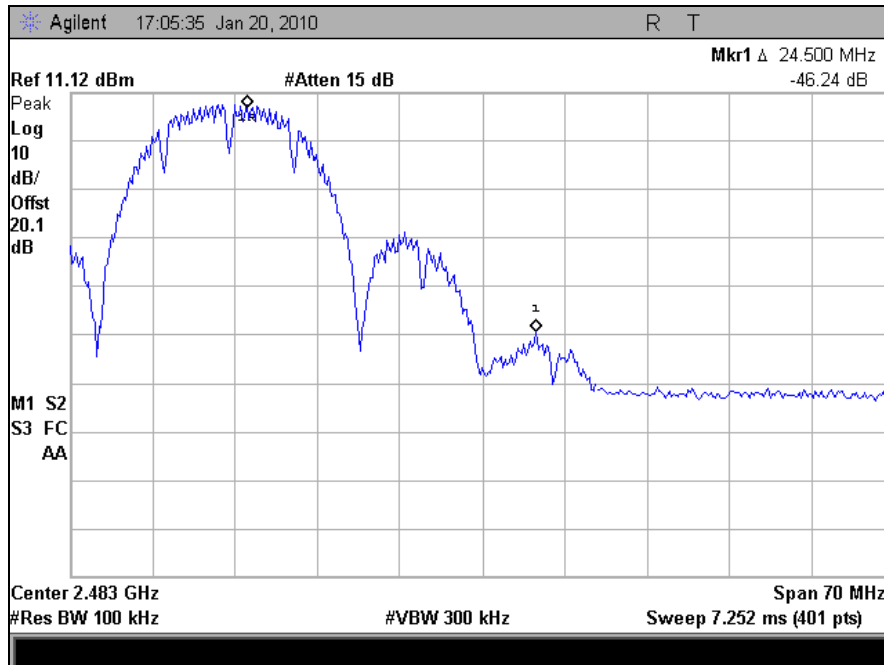


**Plot 87. Conducted Spurious, High Channel, 802.11n (1 GHz - 26 GHz)**

### Conducted Band Edge Test Results

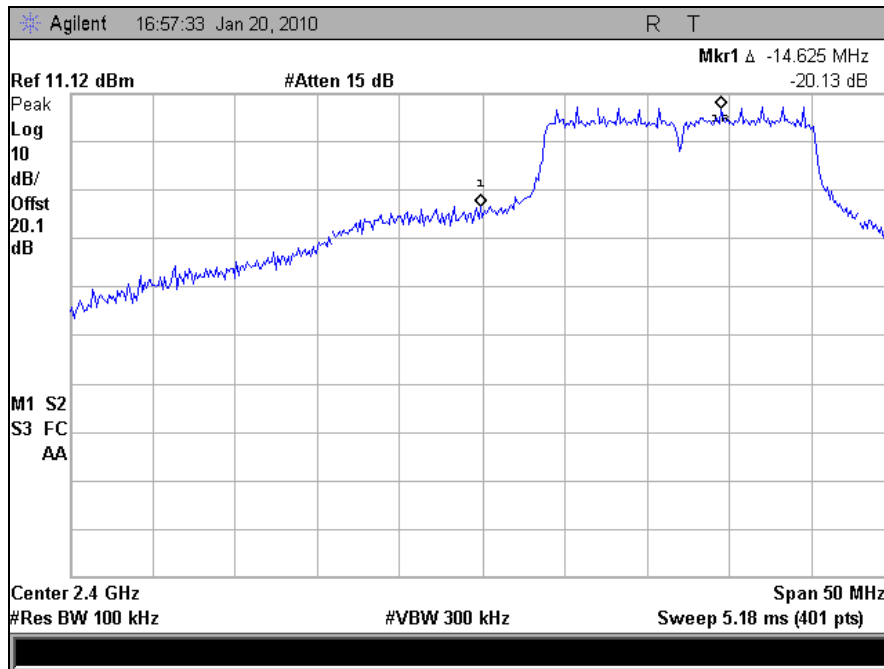


Plot 88. Conducted Band Edge, Low Channel, 802.11b 20MHz

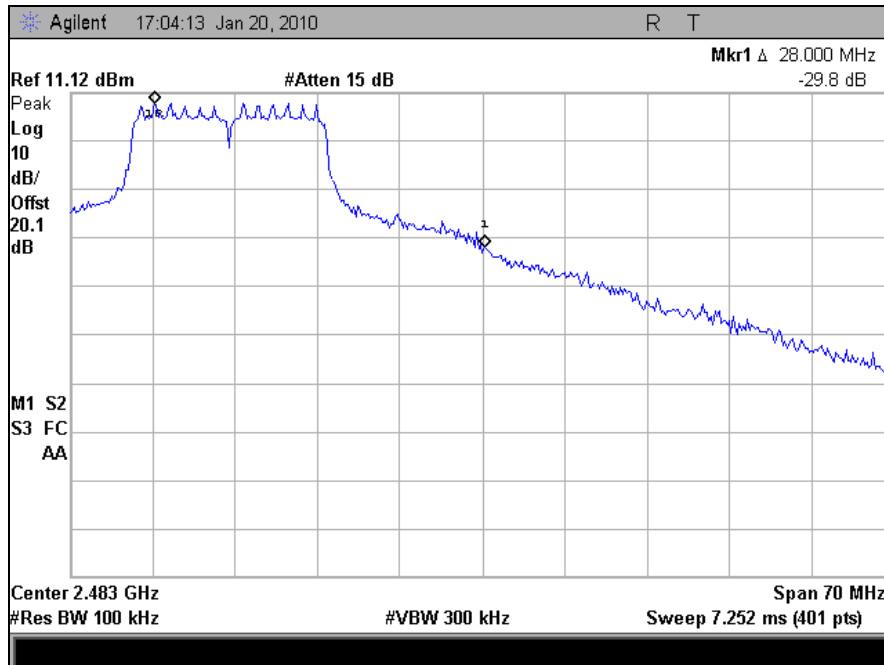


Plot 89. Conducted Band Edge, High Channel, 802.11b 20MHz

### Conducted Band Edge Test Results

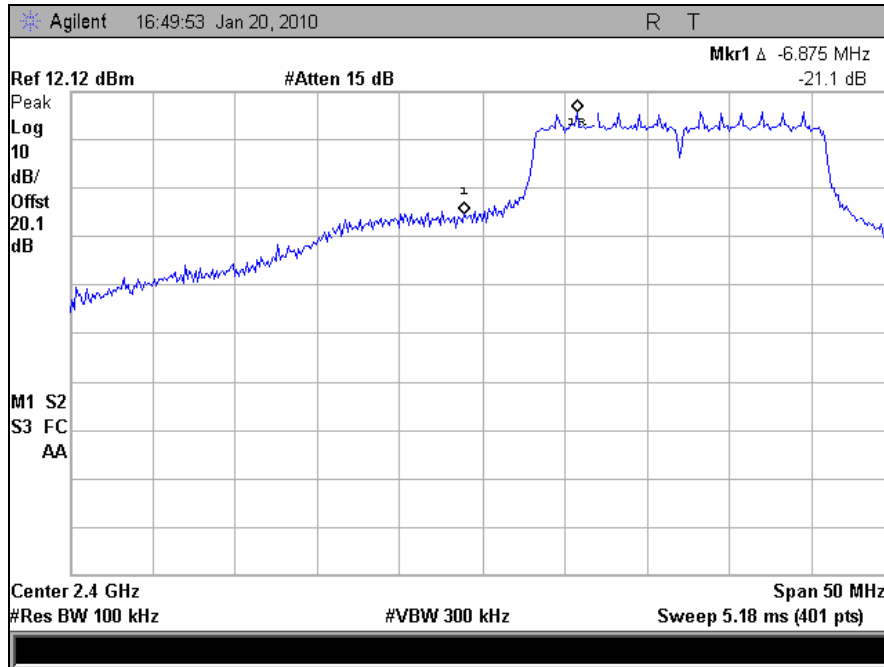


Plot 90. Conducted Band Edge, Low Channel, 802.11g 20MHz

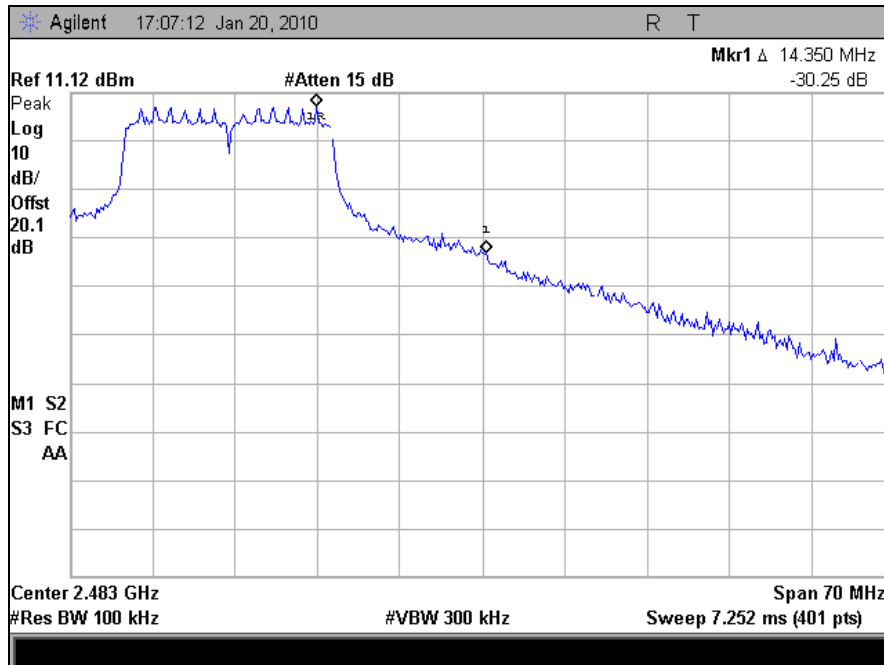


Plot 91. Conducted Band Edge, High Channel, 802.11g 20MHz

### Conducted Band Edge Test Results



**Plot 92. Conducted Band Edge, Low Channel, 802.11n 20MHz**



**Plot 93. Conducted Band Edge, High Channel, 802.11n 20MHz**

## Electromagnetic Compatibility Criteria for Intentional Radiators

### § 15.247(e) Peak Power Spectral Density

- Test Requirements:** §15.247(e): For digitally modulated systems, the peak power spectral density conducted from the intentional radiator to the antenna shall not be greater than 8dBm in any 3 kHz band during any time interval of continuous transmission.
- Test Procedure:** The transmitter was connected directly to a Spectrum Analyzer through an attenuator. The power level was set to the maximum level. A RBW of 1 MHz and VBW of 3 MHz were used to determine the peak emissions within the band. The Spectrum analyzer was then set to a RBW of 3 kHz and VBW was set to 10 kHz. The SPAN of the analyzer was set to 1 MHz with a 333.3 second sweep. Measurements were carried out at the low, mid and high channels.
- Test Results:** The EUT was compliant with the peak power spectral density limits of § 15.247 (e).  
The peak power spectral density was determined from plots on the following page(s).
- Test Engineer:** Anderson Soungpanya
- Test Date:** 01/22/10

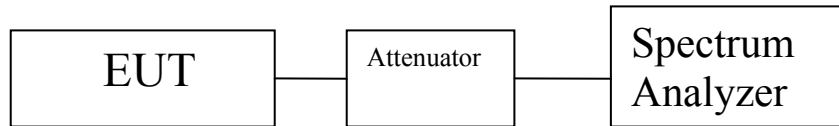


Figure 6. Block Diagram, Peak Power Spectral Density, Test Setup

### Peak Power Spectral Density Test Results

Peak Power Spectral Density				
Carrier Channel	Frequency (MHz)	Measured PPSD (dBm)	Limit (dBm)	Margin (dB)
Low	2412	-5.539	8	-13.539
Mid	2437	-5.577	8	-13.577
High	2462	-1.707	8	-9.707

Table 36. Spectral Density, 802.11b, Test Results

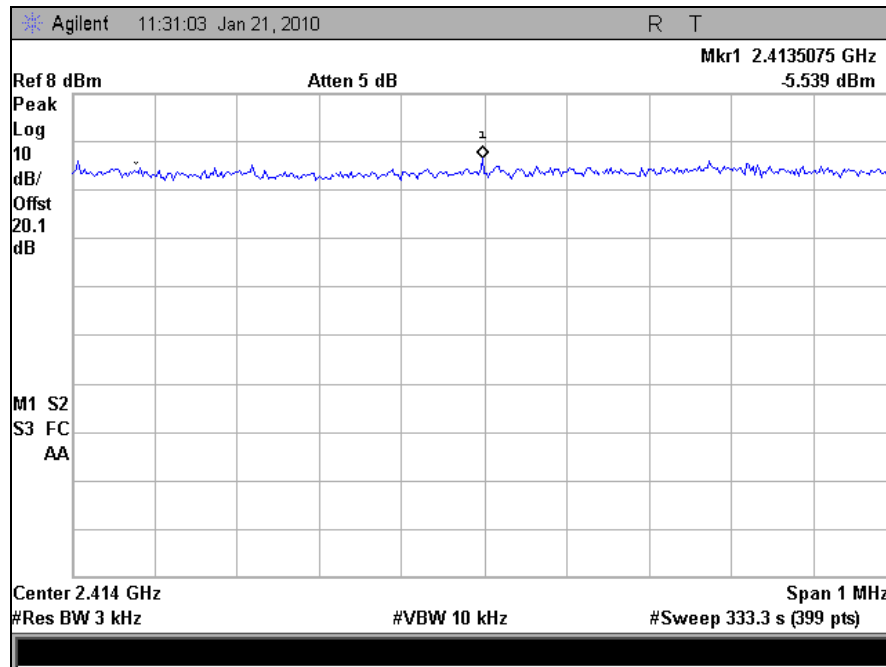
Peak Power Spectral Density				
Carrier Channel	Frequency (MHz)	Measured PPSD (dBm)	Limit (dBm)	Margin (dB)
Low	2412	-5.559	8	-13.559
Mid	2437	-5.463	8	-13.463
High	2462	-4.778	8	-12.778

Table 37. Spectral Density, 802.11g, Test Results

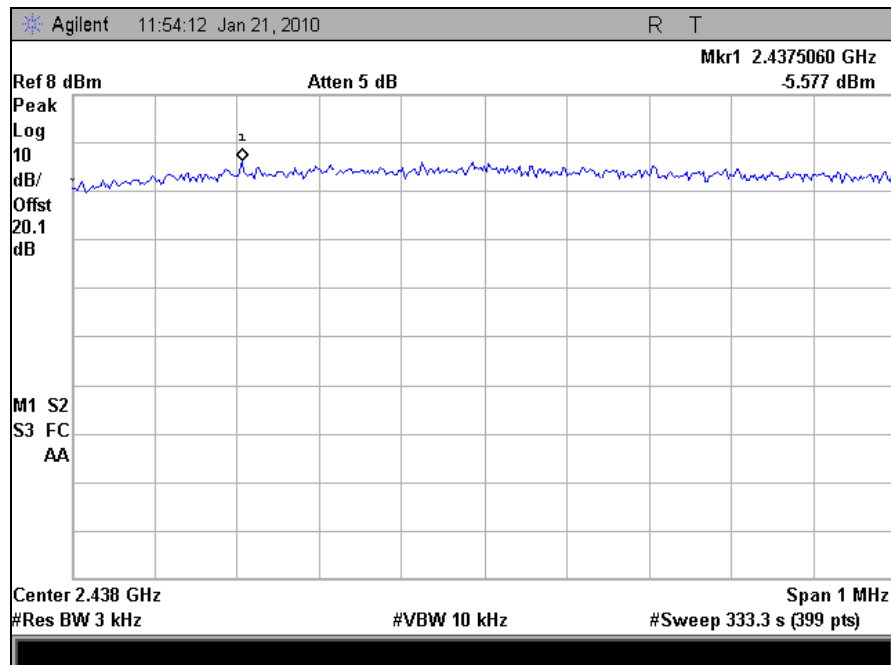
Peak Power Spectral Density				
Carrier Channel	Frequency (MHz)	Measured PPSD (dBm)	Limit (dBm)	Margin (dB)
Low	2412	-5.929	8	-13.929
Mid	2437	-6.127	8	-14.127
High	2462	-5.008	8	-13.008

Table 38. Spectral Density, 802.11n, Test Results

## Peak Power Spectral Density

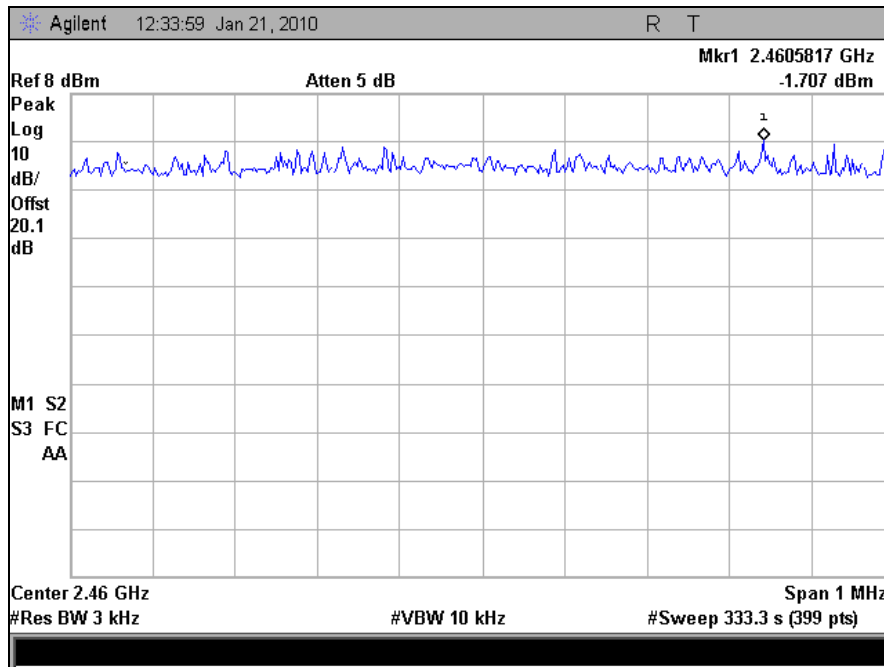


**Plot 94. Peak Spectral Density, Low Channel, 802.11b**

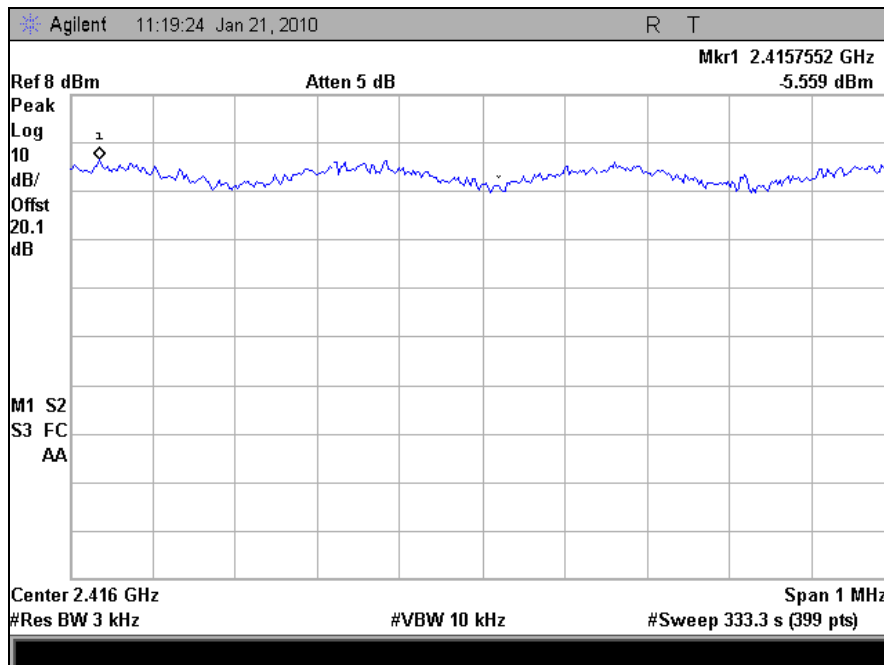


**Plot 95. Peak Spectral Density, Mid Channel, 802.11b**

### Peak Power Spectral Density



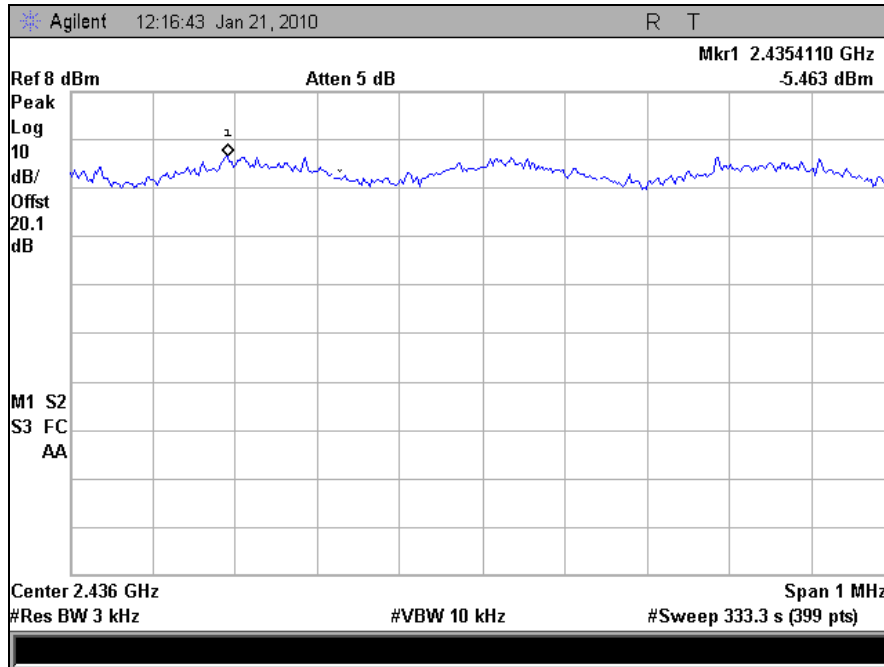
Plot 96. Peak Spectral Density, High Channel, 802.11b



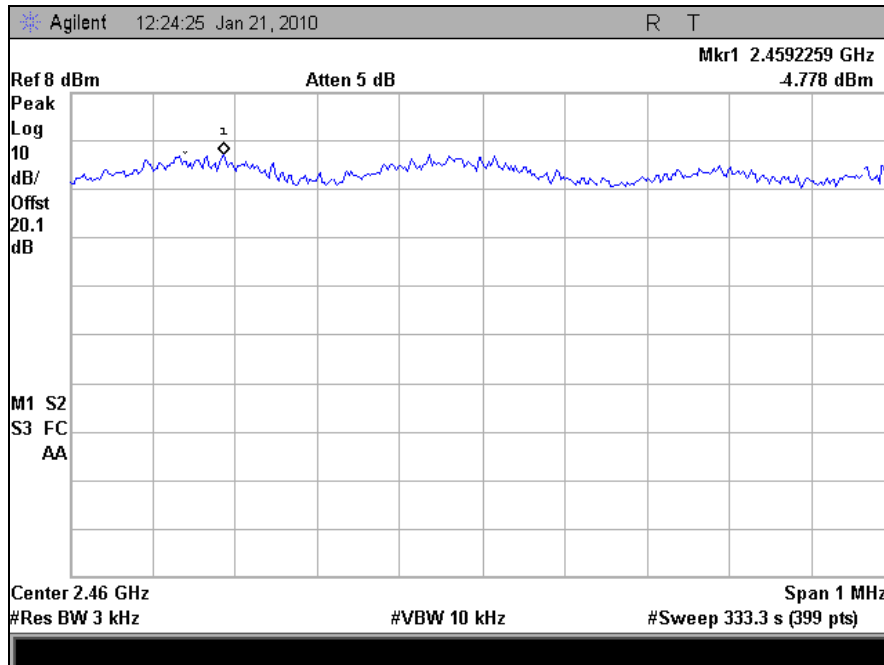
Plot 97. Peak Spectral Density, Low Channel, 802.11g



**Peak Power Spectral Density**

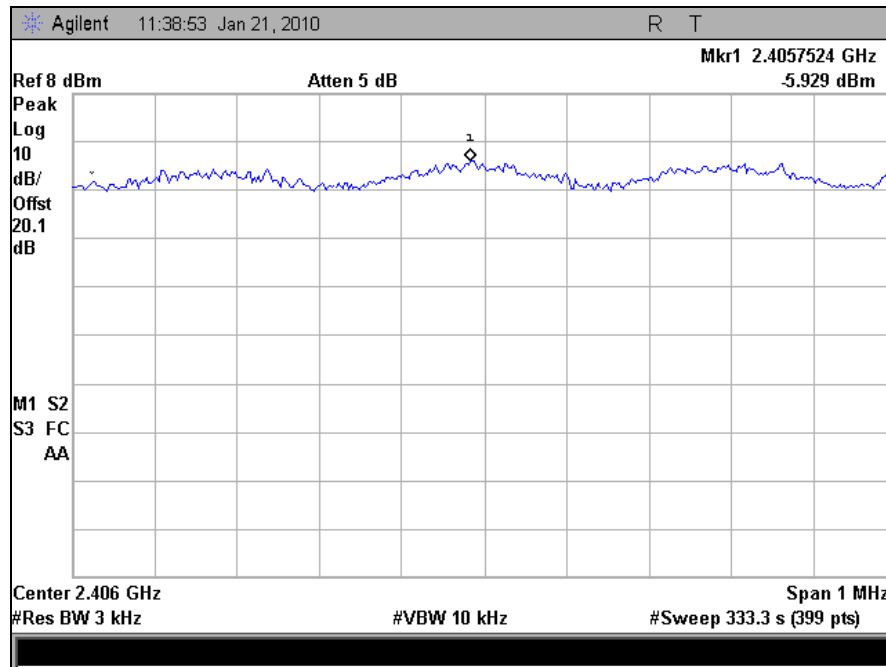


**Plot 98. Peak Spectral Density, Mid Channel, 802.11g**

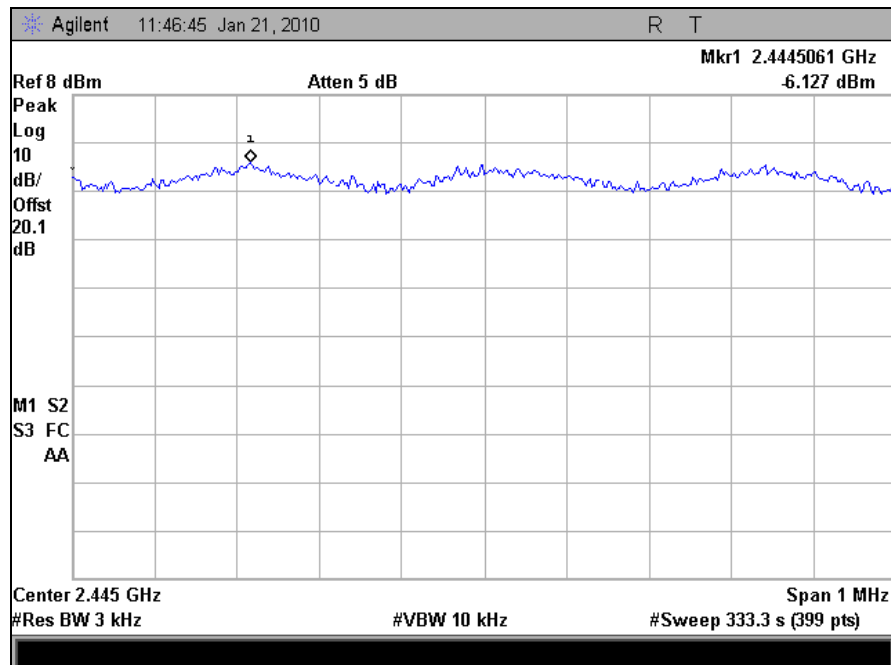


**Plot 99. Peak Spectral Density, High Channel, 802.11g**

## Peak Power Spectral Density

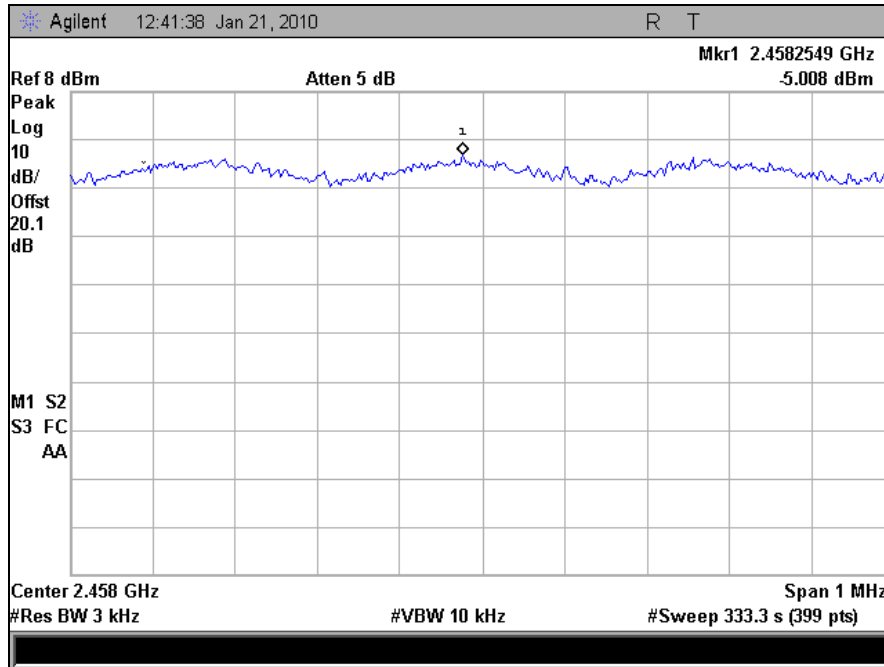


Plot 100. Peak Spectral Density, Low Channel, 802.11n



Plot 101. Peak Spectral Density, Mid Channel, 802.11n

### Peak Power Spectral Density



Plot 102. Peak Spectral Density, High Channel, 802.11n

## IV. Test Equipment

## Test Equipment

Calibrated test equipment utilized during testing was maintained in a current state of calibration per the requirements of ANSI/NCSL Z540-1-1994 and ANSI/ISO/IEC 17025:2000.

MET Asset #	Equipment	Manufacturer	Model	Last Cal Date	Cal Due Date
1S2421	EMI RECEIVER	ROHDE&SCHWARZ	ESIB 7	05/27/2009	05/27/2010
1S2121	PRE-AMPLIFIER	HEWLETT PACKARD	8449B	SEE NOTE	
1S2501	EMI RECEIVER	ROHDE & SCHWARZ	ESU40	4/27/2009	4/27/2010
1S2198	HORN ANTENNA	EMCO	3115	09/03/2009	09/03/2010
1S2128	HARMONIC MIXER	HEWLETT PACKARD	11970A	11/22/2008	11/22/2010
1S2129	HARMONIC MIXER	HEWLETT PACKARD	11970K	11/22/2008	11/22/2010
1S2603	HORN ANTENNA	ETS-LINDGREN	3117	4/9/2009	4/9/2011
1S2202	HORN ANTENNA	EMCO	3116	4/10/2007	4/10/2010
N/A	HIGH PASS FILTER	MICRO-TRONICS	HPM13146	SEE NOTE	
1S2041	COUPLER, BI DIRECTIONAL COAXIAL	NARDA	N/A	SEE NOTE	
1S2460	ANALYZER, SPECTRUM 9 KHZ-40GHZ	AGILENT	E4407B	04/14/2009	04/14/2010
1S508	LISN	SOLAR ELECTRONICS	9252-50-R24-BNC	06/05/2009	06/05/2010
1S2512	TRANSIENT LIMITER	AGILENT	11947A	SEE NOTE	
1S2517	THERMO-HYGROMETER	FISHER SCIENTIFIC	11-661-7D	11/11/2009	11/11/2011
1S2482	CHAMBER, 5 METER	PANASHIELD	641431	10/16/2009	10/16/2010
1S2108	RECIEVER, EMI, RF FILTER SECTION	HEWLETT PACKARD	85460A	11/10/2009	11/10/2010
1S2399	TURNTABLE CONTROLLER	SUNOL SCIENCE	SC99V	SEE NOTE	
1S2485	BILOG ANTENNA	TESEQ	CBL6112D	03/20/2009	03/20/2010
1S2488	SCREEN ROOM 1	UNIVERSAL	NA	1/20/2010	1/20/2011
1S2464	LISN	SOLAR ELECTRONICS	9252-50-R24-BNC	SEE NOTE	
1S2507	LISN	SOLAR ELECTRONICS	9252-50-R-24-BNC	SEE NOTE	
1S2630	TRANSIENT LIMITER	FISCHER CUSTOM COMMUNICATIONS INC.	FCC-450B-2.4-N	1/24/2010	1/24/2011
1S2607	SPECTRUM ANALYZER	AGILENT	E4407B	6/29/2009	6/29/2010

**Table 39. Test Equipment List**

Note: Functionally tested equipment is verified using calibrated instrumentation at the time of testing.

## **V. Certification & User's Manual Information**

## Certification & User's Manual Information

### A. Certification Information

The following is extracted from Title 47 of the Code of Federal Regulations, Part 2, Subpart I — Marketing of Radio frequency devices:

#### § 2.801 Radio-frequency device defined.

As used in this part, a radio-frequency device is any device which in its operation is capable of Emitting radio-frequency energy by radiation, conduction, or other means. Radio- frequency devices include, but are not limited to:

- (a) The various types of radio communication transmitting devices described throughout this chapter.
- (b) *The incidental, unintentional and intentional radiators defined in Part 15 of this chapter.*
- (c) The industrial, scientific, and medical equipment described in Part 18 of this chapter.
- (d) Any part or component thereof which in use emits radio-frequency energy by radiation, conduction, or other means.

#### § 2.803 Marketing of radio frequency devices prior to equipment authorization.

- (a) Except as provided elsewhere in this chapter, no person shall sell or lease, or offer for sale or lease (including advertising for sale or lease), or import, ship or distribute for the purpose of selling or leasing or offering for sale or lease, any radio frequency device unless:
  - (1) In the case of a device subject to certification, such device has been authorized by the Commission in accordance with the rules in this chapter and is properly identified and labeled as required by §2.925 and other relevant sections in this chapter; or
  - (2) In the case of a device that is not required to have a grant of equipment authorization issued by the Commission, but which must comply with the specified technical standards prior to use, such device also complies with all applicable administrative (including verification of the equipment or authorization under a Declaration of Conformity, where required), technical, labeling and identification requirements specified in this chapter.
- (d) Notwithstanding the provisions of paragraph (a) of this section, the offer for sale solely to business, commercial, industrial, scientific or medical users (but not an offer for sale to other parties or to end users located in a residential environment) of a radio frequency device that is in the conceptual, developmental, design or pre-production stage is permitted prior to equipment authorization or, for devices not subject to the equipment authorization requirements, prior to a determination of compliance with the applicable technical requirements *provided* that the prospective buyer is advised in writing at the time of the offer for sale that the equipment is subject to the FCC rules and that the equipment will comply with the appropriate rules before delivery to the buyer or to centers of distribution.

- (e)(1) Notwithstanding the provisions of paragraph (a) of this section, prior to equipment authorization or determination of compliance with the applicable technical requirements any radio frequency device may be operated, but not marketed, for the following purposes and under the following conditions:
- (i) *Compliance testing*;
  - (ii) Demonstrations at a trade show provided the notice contained in paragraph (c) of this section is displayed in a conspicuous location on, or immediately adjacent to, the device;
  - (iii) Demonstrations at an exhibition conducted at a business, commercial, industrial, scientific or medical location, but excluding locations in a residential environment, provided the notice contained in paragraphs (c) or (d) of this section, as appropriate, is displayed in a conspicuous location on, or immediately adjacent to, the device;
  - (iv) Evaluation of product performance and determination of customer acceptability, provided such operation takes place at the manufacturer's facilities during developmental, design or pre-production states; or
  - (v) Evaluation of product performance and determination of customer acceptability where customer acceptability of a radio frequency device cannot be determined at the manufacturer's facilities because of size or unique capability of the device, provided the device is operated at a business, commercial, industrial, scientific or medical user's site, but not at a residential site, during the development, design or pre-production stages.
- (e)(2) For the purpose of paragraphs (e)(1)(iv) and (e)(1)(v) of this section, the term *manufacturer's facilities* includes the facilities of the party responsible for compliance with the regulations and the manufacturer's premises, as well as the facilities of other entities working under the authorization of the responsible party in connection with the development and manufacture, but not the marketing, of the equipment.
- (f) For radio frequency devices subject to verification and sold solely to business, commercial, industrial, scientific and medical users (excluding products sold to other parties or for operation in a residential environment), parties responsible for verification of the devices shall have the option of ensuring compliance with the applicable technical specifications of this chapter at each end user's location after installation, provided that the purchase or lease agreement includes a proviso that such a determination of compliance be made and is the responsibility of the party responsible for verification of the equipment.



## Certification & User's Manual Information

The following is extracted from Title 47 of the Code of Federal Regulations, Part 2, Subpart J — Equipment Authorization Procedures:

### § 2.901 Basis and Purpose

- (a) In order to carry out its responsibilities under the Communications Act and the various treaties and international regulations, and in order to promote efficient use of the radio spectrum, the Commission has developed technical standards for radio frequency equipment and parts or components thereof. The technical standards applicable to individual types of equipment are found in that part of the rules governing the service wherein the equipment is to be operated.<sup>1</sup> *In addition to the technical standards provided, the rules governing the service may require that such equipment be verified by the manufacturer or importer, be authorized under a Declaration of Conformity, or receive an equipment authorization from the Commission by one of the following procedures: certification or registration.*
- (b) The following sections describe the verification procedure, the procedure for a Declaration of Conformity, and the procedures to be followed in obtaining certification from the Commission and the conditions attendant to such a grant.

### § 2.907 Certification.

- (a) Certification is an equipment authorization issued by the Commission, based on representation and test data submitted by the applicant.
- (b) Certification attaches to all units subsequently marketed by the grantee which are identical (see Section 2.908) to the sample tested except for permissive changes or other variations authorized by the Commission pursuant to Section 2.1043.

---

<sup>1</sup> In this case, the equipment is subject to the rules of Part 15. More specifically, the equipment falls under Subpart B (of Part 15), which deals with unintentional radiators.

## Certification & User's Manual Information

### § 2.948 Description of measurement facilities.

- (a) Each party making measurements of equipment that is subject to an equipment authorization under Part 15 or Part 18 of this chapter, regardless of whether the measurements are filed with the Commission or kept on file by the party responsible for compliance of equipment marketed within the U.S. or its possessions, shall compile a description of the measurement facilities employed.
- (1) If the measured equipment is subject to the verification procedure, the description of the measurement facilities shall be retained by the party responsible for verification of the equipment.
- (i) *If the equipment is verified through measurements performed by an independent laboratory, it is acceptable for the party responsible for verification of the equipment to rely upon the description of the measurement facilities retained by or placed on file with the Commission by that laboratory. In this situation, the party responsible for the verification of the equipment is not required to retain a duplicate copy of the description of the measurement facilities.*
- (ii) If the equipment is verified based on measurements performed at the installation site of the equipment, no specific site calibration data is required. It is acceptable to retain the description of the measurement facilities at the site at which the measurements were performed.
- (2) If the equipment is to be authorized by the Commission under the certification procedure, the description of the measurement facilities shall be filed with the Commission's Laboratory in Columbia, Maryland. The data describing the measurement facilities need only be filed once but must be updated as changes are made to the measurement facilities or as otherwise described in this section. At least every three years, the organization responsible for filing the data with the Commission shall certify that the data on file is current.

## Certification & User's Manual Information

### Label and User's Manual Information

The following is extracted from Title 47 of the Code of Federal Regulations, Part 15, Subpart A — General:

#### § 15.19 Labeling requirements.

(a) *In addition to the requirements in Part 2 of this chapter, a device subject to certification or verification shall be labeled as follows:*

- (1) Receivers associated with the operation of a licensed radio service, e.g., FM broadcast under Part 73 of this chapter, land mobile operation under Part 90, etc., shall bear the following statement in a conspicuous location on the device:

This device complies with Part 15 of the FCC Rules. Operation is subject to the condition that this device does not cause harmful interference.

- (2) A stand-alone cable input selector switch, shall bear the following statement in a conspicuous location on the device:

This device is verified to comply with Part 15 of the FCC Rules for use with cable television service.

- (3) All other devices shall bear the following statement in a conspicuous location on the device:

*This device complies with Part 15 of the FCC Rules. Operation is subject to the following two conditions: (1) This device may not cause harmful interference, and (2) this device must accept any interference received, including interference that may cause undesired operation.*

- (4) Where a device is constructed in two or more sections connected by wires and marketed together, the statement specified under paragraph (a) of this section is required to be affixed only to the main control unit.

- (5) When the device is so small or for such use that it is not practicable to place the statement specified under paragraph (a) of this section on it, the information required by this paragraph shall be placed in a prominent location in the instruction manual or pamphlet supplied to the user or, alternatively, shall be placed on the container in which the device is marketed. However, the FCC identifier or the unique identifier, as appropriate, must be displayed on the device.

#### § 15.21 Information to user.

The users manual or instruction manual for an intentional or unintentional radiator shall caution the user that changes or modifications not expressly approved by the party responsible for compliance could void the user's authority to operate the equipment.

## Verification & User's Manual Information

The following is extracted from Title 47 of the Code of Federal Regulations, Part 15, Subpart B — Unintentional Radiators:

### § 15.105 Information to the user.

- (a) For a Class A digital device or peripheral, the instructions furnished the user shall include the following or similar statement, placed in a prominent location in the text of the manual:

Note: This equipment has been tested and found to comply with the limits for a Class A digital device, pursuant to Part 15 of the FCC Rules. These limits are designed to provide reasonable protection against harmful interference when the equipment is operated in a commercial environment. This equipment generates, uses, and can radiate radio frequency energy and, if not installed and used in accordance with the instruction manual, may cause harmful interference to radio communications. Operation of this equipment in a residential area is likely to cause harmful interference in which case the user will be required to correct the interference at own expense.

- (b) For a Class B digital device or peripheral, the instructions furnished the user shall include the following or similar statement, placed in a prominent location in the text of the manual:

Note: This equipment has been tested and found to comply with the limits for a Class B digital device, pursuant to Part 15 of the FCC Rules. These limits are designed to provide reasonable protection against harmful interference when the equipment is operated in a residential environment. This equipment generates, uses, and can radiate radio frequency energy and, if not installed and used in accordance with the instruction manual, may cause harmful interference to radio communications. However, there is no guarantee that interference will not occur in a particular installation. If this equipment does cause harmful interference to radio or television reception, which can be determined by turning the equipment off and on, the user is encouraged to try to correct the interference by one or more of the following measures:

- Reorient or relocate the receiving antenna.
- Increase the separation between the equipment and receiver.
- Connect the equipment into an outlet on a circuit different from that to which the receiver is connected.
- Consult the dealer or an experienced radio/TV technician for help.

## ICES-003 Procedural & Labeling Requirements

From the Industry Canada Electromagnetic Compatibility Advisory Bulletin entitled, "Implementation and Interpretation of the Interference-Causing Equipment Standard for Digital Apparatus, ICES-003" (EMCAB-3, Issue 2, July 1995):

"At present, CISPR 22: 2002 and ICES technical requirements are essentially equivalent. Therefore, if you have CISPR 22: 2002 approval by meeting CISPR Publication 22, the only additional requirements are: to attach a note to the report of the test results for compliance, indicating that these results are deemed satisfactory evidence of compliance with ICES-003 of the Canadian Interference-Causing Equipment Regulations; to maintain these records on file for the requisite five year period; and to provide the device with a notice of compliance in accordance with ICES-003."

### Procedural Requirements:

According to Industry Canada's Interference Causing Equipment Standard for Digital Apparatus ICES-003 Issue 4, February 2004:

- Section 6.1: A record of the measurements and results, showing the date that the measurements were completed, shall be retained by the manufacturer or importer for a period of at least five years from the date shown in the record and made available for examination on the request of the Minister.
- Section 6.2: A written notice indicating compliance must accompany each unit of digital apparatus to the end user. The notice shall be in the form of a label that is affixed to the apparatus. Where because of insufficient space or other constraints it is not feasible to affix a label to the apparatus, the notice may be in the form of a statement in the user's manual.

### Labeling Requirements:

The suggested text for the notice, in English and in French, is provided below, from the Annex of ICES-003:

This Class [<sup>2</sup>] digital apparatus complies with Canadian ICES-003.

Cet appareil numérique de la classe [<sup>1</sup>] est conforme à la norme NMB-003 du Canada.

---

<sup>2</sup> Insert either A or B but not both as appropriate for the equipment requirements.

# End of Report