



FCC TEST REPORT

According to

FCC Rules and Regulations Part 15 Subpart C

Applicant : Ubiquiti Networks, Inc.
Address : 12F, No. 105, Song Ren Rd., Sin Yi District,
Taipei 110, Taiwan
Equipment : AirGateWay
Model No. : AirGateWay, AirGateWay -LR
FCC ID : SWX-AGW
Trade Name : Ubiquiti

- The test result refers exclusively to the test presented test model / sample.,
- Without written approval of **CerpPASS Technology Corp.**, the test report shall not be reproduced except in full.
- The EUT is also considered as a kind of computer peripheral, because the connection to computer is necessary for typical use. It has been verified to comply with the requirements of FCC Part 15, Subpart B, Class B (DoC). The test report has been issued separately.



Contents

1. Report of Measurements and Examinations	6
1.1 List of Measurements and Examinations	6
2. Test Configuration of Equipment under Test	7
2.1 Feature of Equipment under Test	7
2.2 Carrier Frequency of Channels	7
2.3 Test Mode and Test Software	8
2.4 Description of Test System	8
2.5 General Information of Test	9
2.6 Measurement Uncertainty	9
3. Antenna Requirements	10
3.1 Standard Applicable	10
3.2 Antenna Construction and Directional Gain	10
4. Test of Conducted Emission	11
4.1 Test Limit	11
4.2 Test Procedures	11
4.3 Typical Test Setup	12
4.4 Measurement Equipment	12
4.5 Test Result and Data	13
4.6 Test Photographs	19
5. Test of Radiated Emission	20
5.1 Test Limit	20
5.2 Test Procedures	20
5.3 Typical Test Setup	21
5.4 Measurement Equipment	21
5.5 Test Result and Data (9kHz ~ 30MHz)	21
5.6 Test Result and Data	22
5.7 Test Photographs (30MHz~1GHz)	58
5.8 Test Photographs (1GHz~25GHz)	59
6. 6dB Bandwidth Measurement Data	60
6.1 Test Limit	60
6.2 Test Procedures	60
6.3 Test Setup Layout	60
6.4 Measurement Equipment	60
6.5 Test Result and Data	60
7. Maximum Peak and Average Output Power	67
7.1 Test Limit	67
7.2 Test Procedures	67
7.3 Test Setup Layout	67
7.4 Measurement Equipment	67
7.5 Test Result and Data	68
8. Power Spectral Density	69
8.1 Test Limit	69
8.2 Test Procedures	69



8.3 Test Setup Layout 69

8.4 Measurement Equipment..... 69

8.5 Test Result and Data 69

9. Band Edges Measurement 76

9.1 Test Limit 76

9.2 Test Procedure 76

9.3 Test Setup Layout 76

9.4 Measurement Equipment..... 76

9.5 Test Result and Data 76

9.6 Restrict Band Emission Measurement Data 85

10. Restricted Bands of Operation 87

10.1 Labeling Requirement 87

Appendix A. Photographs of EUT..... A1 ~ A8



History of this test report

ORIGINAL.

Additional attachment as following record:

Attachment No.	Issue Date	Description
TEF11211174	Jan. 21, 2013	Original
TEF11211174-A	Nov. 13, 2013	Add a dipole antenna (gain: 5dBi) and model no.



CERTIFICATE OF COMPLIANCE

According to

FCC Rules and Regulations Part 15 Subpart C

Applicant : Ubiquiti Networks, Inc.
Address : 12F, No. 105, Song Ren Rd., Sin Yi District,
Taipei 110, Taiwan
Equipment : AirGateWay
Model No. : AirGateWay, AirGateWay -LR
FCC ID : SWX-AGW

I **HEREBY** CERTIFY THAT :

The measurements shown in this test report were made in accordance with the procedures given in **ANSI C63.4 2009, KDB558074 & KDB662911**.

The equipment was **passed** the test performed according to **FCC Rules and Regulations Part 15 Subpart C (2010)**.

The test was carried out on Nov. 06, 2013 at CerpPASS Technology Corp.

Approved by:

Tested by:

Hill Chen
EMC/RF B.U. Assistant Manager

Tom Tai
Engineer



1. Report of Measurements and Examinations

1.1 List of Measurements and Examinations

FCC Rule	Description of Test	Result
15.203	. Antenna Requirement	Pass
15.207	. Conducted Emission	Pass
15.209 15.247(d)	. Radiated Emission	Pass
15.247(a)(2)	. 6dB Bandwidth	Pass
15.247(b)	. Maximum Peak Output Power	Pass
15.247(d)	. 100kHz Bandwidth of Frequency Band Edges	Pass
15.247(e)	. Power Spectral Density	Pass
1.1307 1.1310 2.1091 2.1093	. RF Exposure Compliance	Pass



2. Test Configuration of Equipment under Test

2.1 Feature of Equipment under Test

Processor Specs	Atheros
Networking Interface	2X10/100 BASE-TX (Cat. 5, RJ-45) Ethernet
Operating Temperature	0°C to 40°C
Operating Humidity	5% to 95% Condensing
RF Spec.	
Parameter	Specification
Frequency range	2.4–2.48 GHz
Input	VSWR 2:1 max.
Peak gain	+1 dBi, +5 dBi
Radiation pattern	Omni directional for XY plane, vertical polarization
Polarization	Linear
Cross-polarization	5 dB, typical

2.2 Carrier Frequency of Channels

802.11b, 802.11g, 802.11n HT 20

Channel	Frequency(MHz)	Channel	Frequency(MHz)
01	2412	07	2442
02	2417	08	2447
03	2422	09	2452
04	2427	10	2457
05	2432	11	2462
06	2437	---	---

802.11n, HT40

Channel	Frequency(MHz)	Channel	Frequency(MHz)
---	---	08	2447
---	---	09	2452
03	2422	---	---
04	2427	---	---
05	2432	---	---
06	2437	---	---
07	2442	---	---



2.3 Test Mode and Test Software

- a. During testing, the interface cables and equipment positions were varied according to ANSI C63.4.
- b. The complete test system included Notebook, Mouse and EUT for RF test.
- c. An executive program, "ART2" under WIN XP was executed to transmit and receive data through WLAN.
- d. The following test modes were performed for test:
 - 802.11b/g/n HT20: CH01: 2412MHz, CH06: 2437MHz, CH11: 2462MHz
 - 802.11n HT40: CH03: 2422MHz, CH06: 2437MHz, CH09: 2452MHz

* Power output of data rate:

802.11b		802.11g		802.11n HT20		802.11n HT40	
Data Rate (Mbps)	Power output (dBm)	Data Rate (Mbps)	Power output (dBm)	Data Rate (Mbps)	Power output (dBm)	Data Rate (Mbps)	Power output (dBm)
11	19.47	54	18.50	130/15	---	270/15	---
5.5	19.44	48	18.54	117/14	---	243/14	---
2	19.42	36	18.61	104/13	---	216/13	---
1	19.41	24	18.63	78/12	---	162/12	---
---	---	18	18.64	52/11	---	108/11	---
---	---	12	18.66	39/10	---	81/10	---
---	---	9	18.74	26/9	---	54/9	---
---	---	6	18.79	13/8	---	27/8	---
---	---	---	---	65/7	18.54	135/7	17.99
---	---	---	---	58.5/6	18.60	121.5/6	17.94
---	---	---	---	52/5	18.64	108/5	17.99
---	---	---	---	39/4	18.68	81/4	18.07
---	---	---	---	26/3	18.72	54/3	18.12
---	---	---	---	19.5/2	18.75	40.5/2	18.18
---	---	---	---	13/1	18.78	27/1	18.31
---	---	---	---	6.5/0	18.83	13.5/0	18.39

2.4 Description of Test System

Device	Manufacturer	Model No.	Description
Notebook	ASUS	A8J	Power Cable, Unshielding 1.8m
Mouse	DELL	M-UV83	USB Cable, Shielding 1.85m

Use Cable:

Cable	Quantity	Description
RJ45	1	Unshielding, 1m



2.5 General Information of Test

Test Site :	CerpPASS Technology Corp. 2F-11, No. 3, Yuan Qu St., (Nankang Software Park), Taipei, Taiwan 115, R.O.C.
Test Site Location (OATS2-SD) :	No.68-1, Shihbachongsi, Shihding Township, Taipei City 223, Taiwan, R.O.C.
FCC Registration Number:	TW1049, TW1061, 390316, 488071
IC Registration Number :	4934B-1, 4934D-1
VCCI Registration Number:	T-1173 for Telecommunication Test C-4139 for Conducted emission test R-3428 for Radiated emission test G-97 for Radiated emission test above 1GHz
Frequency Range Investigated:	Conducted: from 150kHz to 30MHz Radiation: from 30MHz to 25,000MHz
Test Distance:	The test distance of radiated emission from antenna to EUT is 3 M.
Laboratory Accreditation	

2.6 Measurement Uncertainty

Measurement Item	Uncertainty
Radiated emission	± 4.11 dB
Peak Output Power(conducted)	± 1.38 dB
Peak Output Power(Radiated)	± 1.70 dB
Power Spectral Density	± 1.39 dB
Radiated emission(3m)	± 4.11 dB
Radiated emission(10m)	± 3.89 dB



3. Antenna Requirements

3.1 Standard Applicable

For intentional device, according to FCC 47 CFR Section 15.203, an intentional radiator shall be designed to ensure that no antenna other than that furnished by the responsible party shall be used with the device.

And according to FCC 47 CFR Section 15.247 (b), if transmitting antennas of directional gain greater than 6dBi are used, the power shall be reduced by the amount in dB that the directional gain of the antenna exceeds 6dBi.

3.2 Antenna Construction and Directional Gain

1. Antenna Type: PIFA Antenna
Antenna Gain: 1dBi
2. Antenna Type: Dipole Antenna
Antenna Gain: 5dBi



4. Test of Conducted Emission

4.1 Test Limit

Conducted Emissions were measured from 150 kHz to 30 MHz with a bandwidth of 9 KHz on the 120 VAC power and return leads of the EUT according to the methods defined in ANSI C63.4-2009 Section 3.1. The EUT was placed on a nonmetallic stand in a shielded room 0.8 meters above the ground plane as shown in section 2.2. The interface cables and equipment positioning were varied within limits of reasonable applications to determine the position produced maximum conducted emissions.

Frequency (MHz)	Quasi Peak (dB μ V)	Average (dB μ V)
0.15 – 0.5	66-56*	56-46*
0.5 – 5.0	56	46
5.0 – 30.0	60	50

*Decreases with the logarithm of the frequency.

4.2 Test Procedures

- a. The EUT was placed 0.4 meter from the conducting wall of the shielding room was kept at least 80 centimeters from any other grounded conducting surface.
- b. Connect EUT to the power mains through a line impedance stabilization network (LISN).
- c. All the support units are connecting to the other LISN.
- d. The LISN provides 50 ohm coupling impedance for the measuring instrument.
- e. The FCC states that a 50 ohm, 50 micro-Henry LISN should be used.
- f. Both sides of AC line were checked for maximum conducted interference.
- g. The frequency range from 150 kHz to 30 MHz was searched.
- h. Set the test-receiver system to Peak Detect Function and Specified Bandwidth with Maximum Hold Mode.



4.3 Typical Test Setup

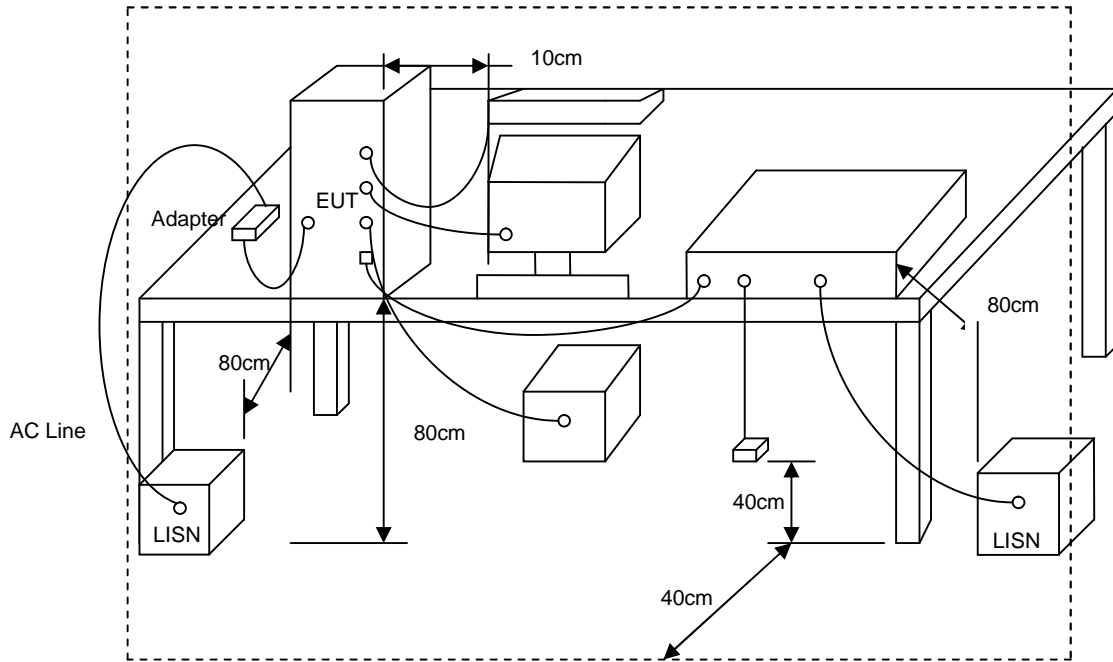

4.4 Measurement Equipment

Instrument/Ancillary	Model No.	Manufacturer	Serial No.	Calibration Date	Valid Date
EMI Receiver	R&S	ESCI	100821	2013/09/18	2014/09/17
LISN	Schwarzbeck	NSLK 8127	8127-516	2013/03/08	2014/03/07
LISN	Schwarzbeck	NSLK 8127	8127-568	2013/08/30	2014/08/29
Attenuator	HAMEG	HZ560	-----	2013/03/07	2014/03/06



4.5 Test Result and Data

Power	: AC 120V	Pol/Phase	: LINE
Test Mode 1	: 802.11g, CH1	Temperature	: 26 °C
Test Date	: Nov. 06, 2013	Humidity	: 60 %

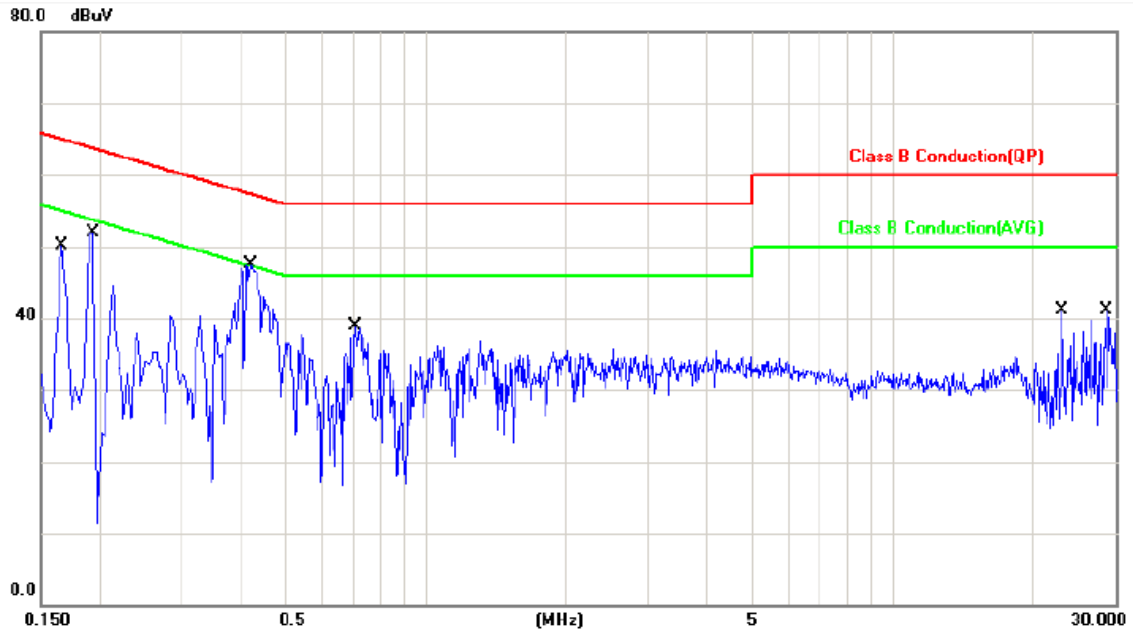

No.	Frequency (MHz)	Factor (dBuV)	Reading (dBuV)	Level (dBuV)	Limit (dBuV)	Margin (dB)	Detector	P/F
1	0.1660	0.12	48.26	48.38	65.15	-16.77	QP	P
2	0.1660	0.12	27.54	27.66	55.15	-27.49	AVG	P
3	0.1940	0.12	48.25	48.37	63.86	-15.49	QP	P
4	0.1940	0.12	25.33	25.45	53.86	-28.41	AVG	P
5	0.4220	0.13	46.64	46.77	57.41	-10.64	QP	P
6	0.4220	0.13	36.21	36.34	47.41	-11.07	AVG	P
7	0.7100	0.17	37.45	37.62	56.00	-18.38	QP	P
8	0.7100	0.17	27.62	27.79	46.00	-18.21	AVG	P
9	23.1299	1.10	40.52	41.62	60.00	-18.38	QP	P
10	23.1299	1.10	35.74	36.84	50.00	-13.16	AVG	P
11	28.6860	1.32	38.46	39.78	60.00	-20.22	QP	P
12	28.6860	1.32	34.55	35.87	50.00	-14.13	AVG	P

Note: Level = Reading + Factor
Margin = Level – Limit



Power	: AC 120V	Pol/Phase	: NEUTRAL
Test Mode 1	: 802.11g, CH1	Temperature	: 26 °C
Test Date	: Nov. 06, 2013	Humidity	: 60 %

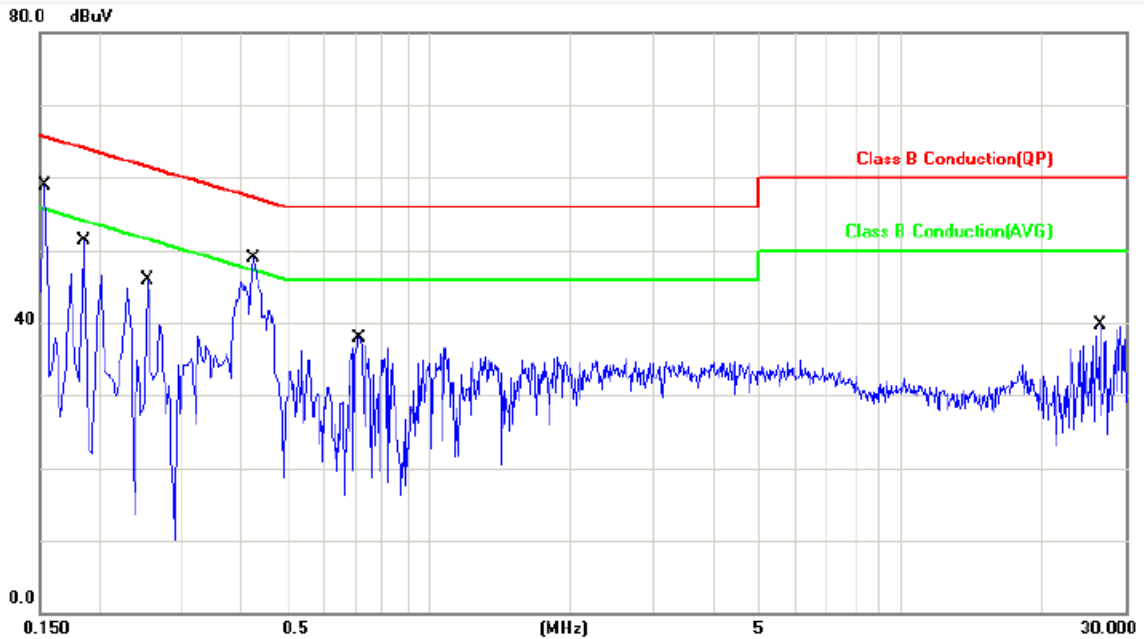

No.	Frequency (MHz)	Factor (dBuV)	Reading (dBuV)	Level (dBuV)	Limit (dBuV)	Margin (dB)	Detector	P/F
1	0.1539	0.12	54.23	54.35	65.78	-11.43	QP	P
2	0.1539	0.12	32.77	32.89	55.78	-22.89	AVG	P
3	0.1860	0.12	50.54	50.66	64.21	-13.55	QP	P
4	0.1860	0.12	30.67	30.79	54.21	-23.42	AVG	P
5	0.2540	0.12	41.78	41.90	61.62	-19.72	QP	P
6	0.2540	0.12	28.49	28.61	51.62	-23.01	AVG	P
7	0.4260	0.13	46.66	46.79	57.33	-10.54	QP	P
8	0.4260	0.13	36.84	36.97	47.33	-10.36	AVG	P
9	0.7100	0.17	36.42	36.59	56.00	-19.41	QP	P
10	0.7100	0.17	26.35	26.52	46.00	-19.48	AVG	P
11	26.4860	1.23	35.73	36.96	60.00	-23.04	QP	P
12	26.4860	1.23	31.69	32.92	50.00	-17.08	AVG	P

Note: Level = Reading + Factor
Margin = Level - Limit



Power	: AC 120V	Pol/Phase	: LINE
Test Mode 2	: 802.11n HT20, CH1	Temperature	: 26 °C
Test Date	: Nov. 06, 2013	Humidity	: 60 %

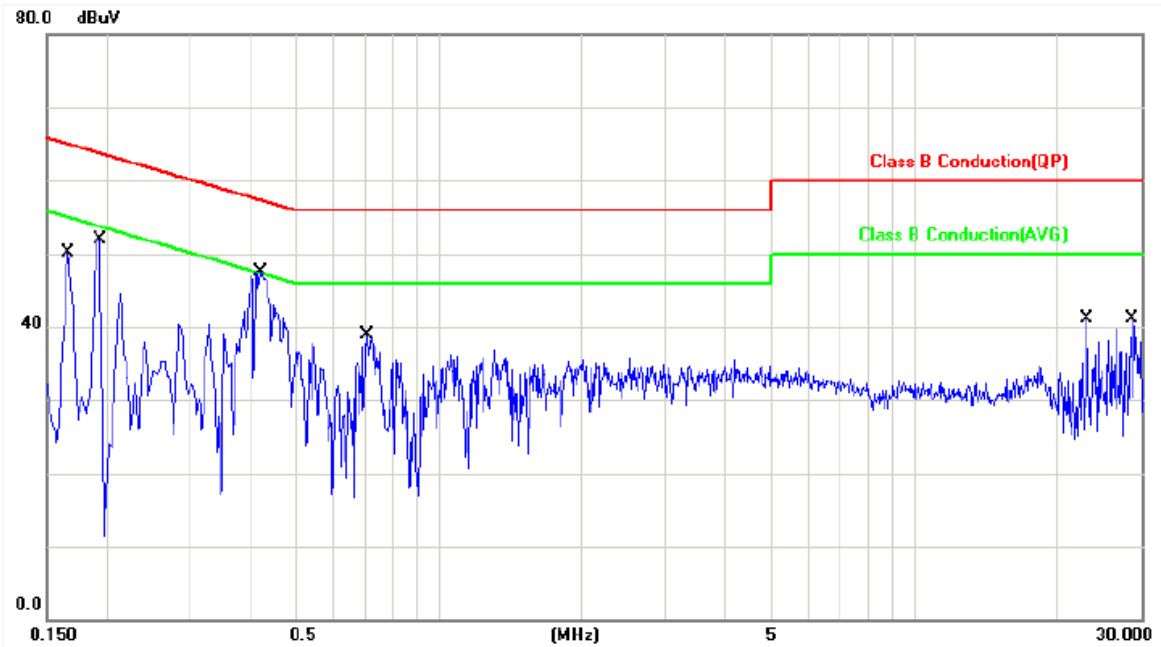

No.	Frequency (MHz)	Factor (dBuV)	Reading (dBuV)	Level (dBuV)	Limit (dBuV)	Margin (dB)	Detector	P/F
1	0.1660	0.12	48.68	48.80	65.15	-16.35	QP	P
2	0.1660	0.12	27.58	27.70	55.15	-27.45	AVG	P
3	0.1940	0.12	48.42	48.54	63.86	-15.32	QP	P
4	0.1940	0.12	25.36	25.48	53.86	-28.38	AVG	P
5	0.4220	0.13	46.57	46.70	57.41	-10.71	QP	P
6	0.4220	0.13	36.12	36.25	47.41	-11.16	AVG	P
7	0.7100	0.17	37.47	37.64	56.00	-18.36	QP	P
8	0.7100	0.17	27.66	27.83	46.00	-18.17	AVG	P
9	23.1299	1.10	40.42	41.52	60.00	-18.48	QP	P
10	23.1299	1.10	35.46	36.56	50.00	-13.44	AVG	P
11	28.6860	1.32	38.51	39.83	60.00	-20.17	QP	P
12	28.6860	1.32	34.75	36.07	50.00	-13.93	AVG	P

Note: Level = Reading + Factor
Margin = Level – Limit



Power	: AC 120V	Pol/Phase	: NEUTRAL
Test Mode 2	: 802.11n HT20, CH1	Temperature	: 26 °C
Test Date	: Nov. 06, 2013	Humidity	: 60 %

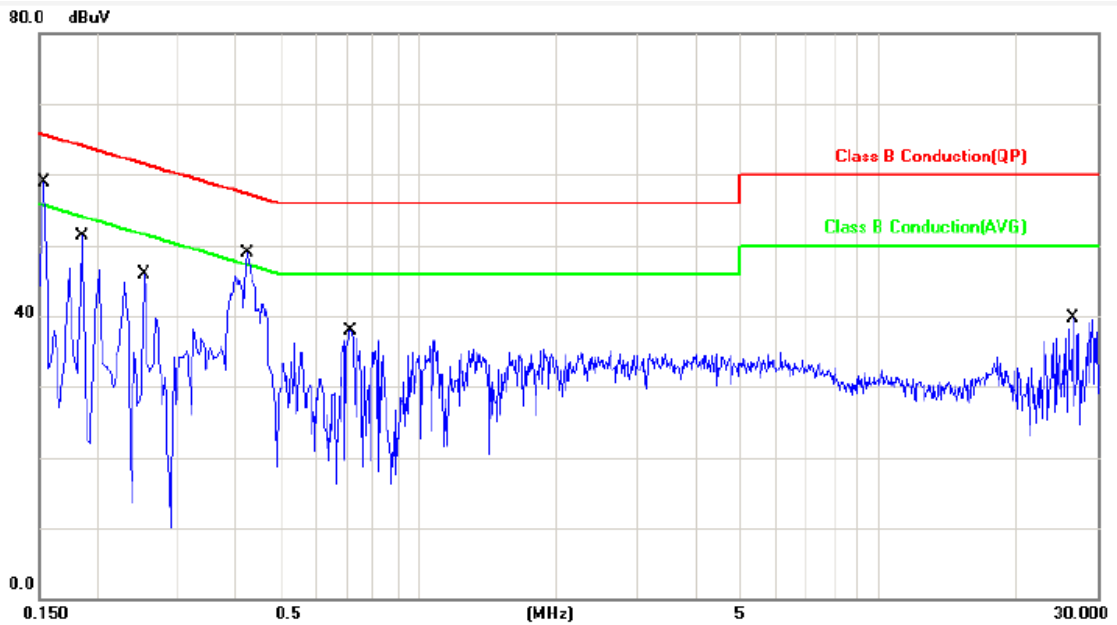

No.	Frequency (MHz)	Factor (dBuV)	Reading (dBuV)	Level (dBuV)	Limit (dBuV)	Margin (dB)	Detector	P/F
1	0.1539	0.12	54.48	54.60	65.78	-11.18	QP	P
2	0.1539	0.12	32.56	32.68	55.78	-23.10	AVG	P
3	0.1860	0.12	50.41	50.53	64.21	-13.68	QP	P
4	0.1860	0.12	30.94	31.06	54.21	-23.15	AVG	P
5	0.2540	0.12	41.74	41.86	61.62	-19.76	QP	P
6	0.2540	0.12	28.35	28.47	51.62	-23.15	AVG	P
7	0.4260	0.13	46.84	46.97	57.33	-10.36	QP	P
8	0.4260	0.13	36.67	36.80	47.33	-10.53	AVG	P
9	0.7100	0.17	36.42	36.59	56.00	-19.41	QP	P
10	0.7100	0.17	26.37	26.54	46.00	-19.46	AVG	P
11	26.4860	1.23	35.69	36.92	60.00	-23.08	QP	P
12	26.4860	1.23	31.33	32.56	50.00	-17.44	AVG	P

Note: Level = Reading + Factor
Margin = Level – Limit



Power	: AC 120V	Pol/Phase	: LINE
Test Mode 3	: 802.11n HT40, CH3	Temperature	: 26 °C
Test Date	: Nov. 06, 2013	Humidity	: 60 %

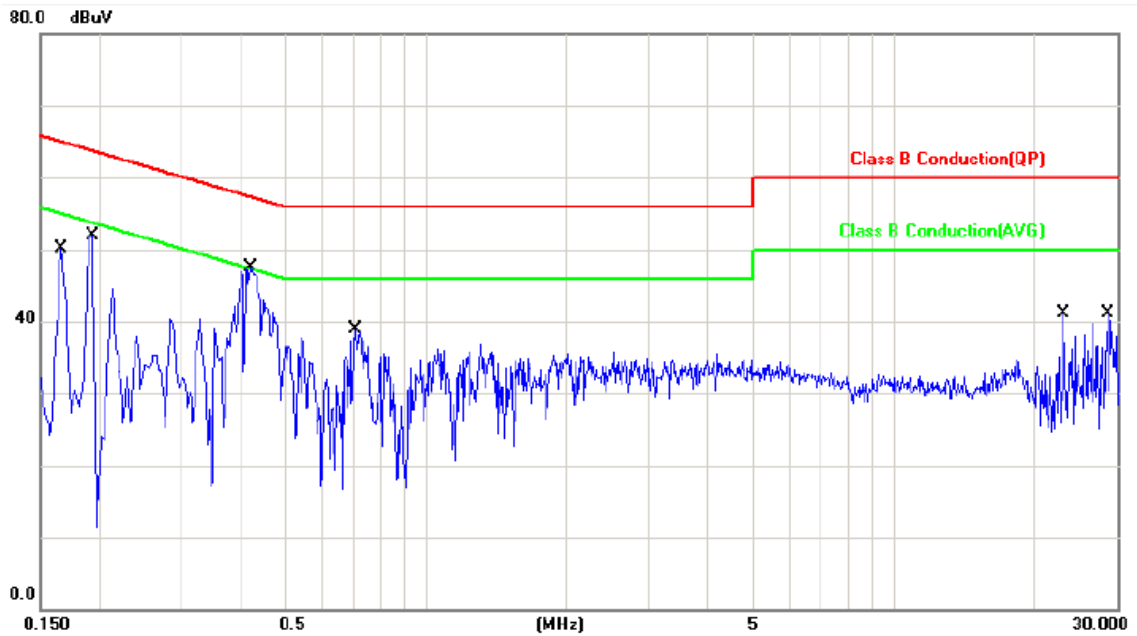

No.	Frequency (MHz)	Factor (dBuV)	Reading (dBuV)	Level (dBuV)	Limit (dBuV)	Margin (dB)	Detector	P/F
1	0.1660	0.12	48.84	48.96	65.15	-16.19	QP	P
2	0.1660	0.12	27.67	27.79	55.15	-27.36	AVG	P
3	0.1940	0.12	48.53	48.65	63.86	-15.21	QP	P
4	0.1940	0.12	25.21	25.33	53.86	-28.53	AVG	P
5	0.4220	0.13	46.54	46.67	57.41	-10.74	QP	P
6	0.4220	0.13	36.15	36.28	47.41	-11.13	AVG	P
7	0.7100	0.17	37.27	37.44	56.00	-18.56	QP	P
8	0.7100	0.17	27.87	28.04	46.00	-17.96	AVG	P
9	23.1299	1.10	40.45	41.55	60.00	-18.45	QP	P
10	23.1299	1.10	35.75	36.85	50.00	-13.15	AVG	P
11	28.6860	1.32	38.59	39.91	60.00	-20.09	QP	P
12	28.6860	1.32	34.76	36.08	50.00	-13.92	AVG	P

Note: Level = Reading + Factor
Margin = Level – Limit



Power	: AC 120V	Pol/Phase	: NEUTRAL
Test Mode 3	: 802.11n HT40, CH3	Temperature	: 26 °C
Test Date	: Nov. 06, 2013	Humidity	: 60 %

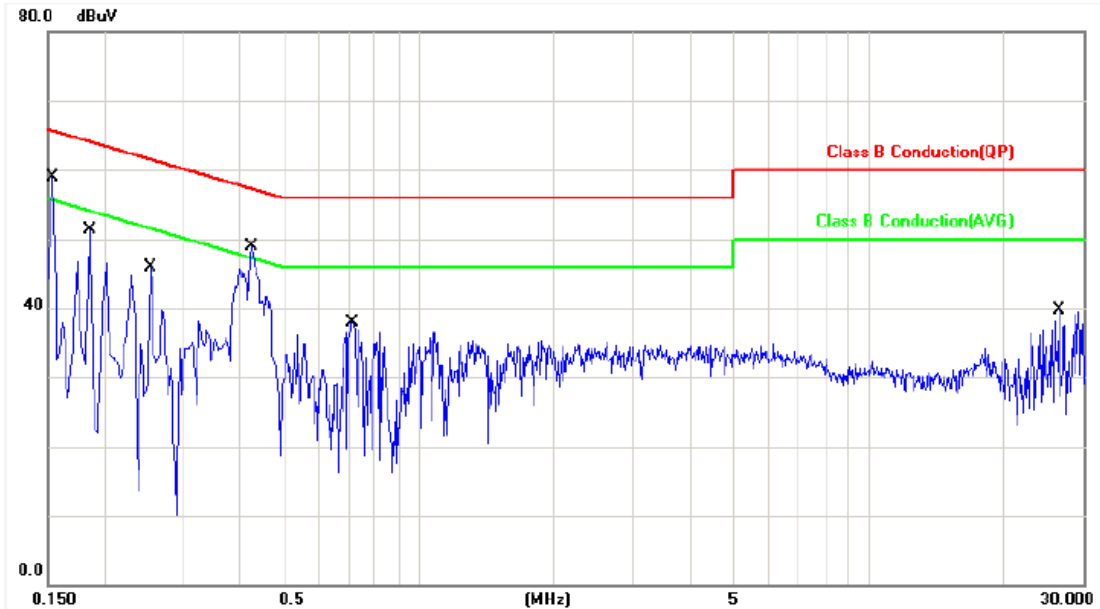

No.	Frequency (MHz)	Factor (dBuV)	Reading (dBuV)	Level (dBuV)	Limit (dBuV)	Margin (dB)	Detector	P/F
1	0.1539	0.12	54.23	54.35	65.78	-11.43	QP	P
2	0.1539	0.12	32.74	32.86	55.78	-22.92	AVG	P
3	0.1860	0.12	50.58	50.70	64.21	-13.51	QP	P
4	0.1860	0.12	30.69	30.81	54.21	-23.40	AVG	P
5	0.2540	0.12	41.85	41.97	61.62	-19.65	QP	P
6	0.2540	0.12	28.42	28.54	51.62	-23.08	AVG	P
7	0.4260	0.13	46.51	46.64	57.33	-10.69	QP	P
8	0.4260	0.13	36.85	36.98	47.33	-10.35	AVG	P
9	0.7100	0.17	36.25	36.42	56.00	-19.58	QP	P
10	0.7100	0.17	26.34	26.51	46.00	-19.49	AVG	P
11	26.4860	1.23	35.68	36.91	60.00	-23.09	QP	P
12	26.4860	1.23	31.75	32.98	50.00	-17.02	AVG	P

Note: Level = Reading + Factor
Margin = Level – Limit



4.6 Test Photographs

Front View



Rear View

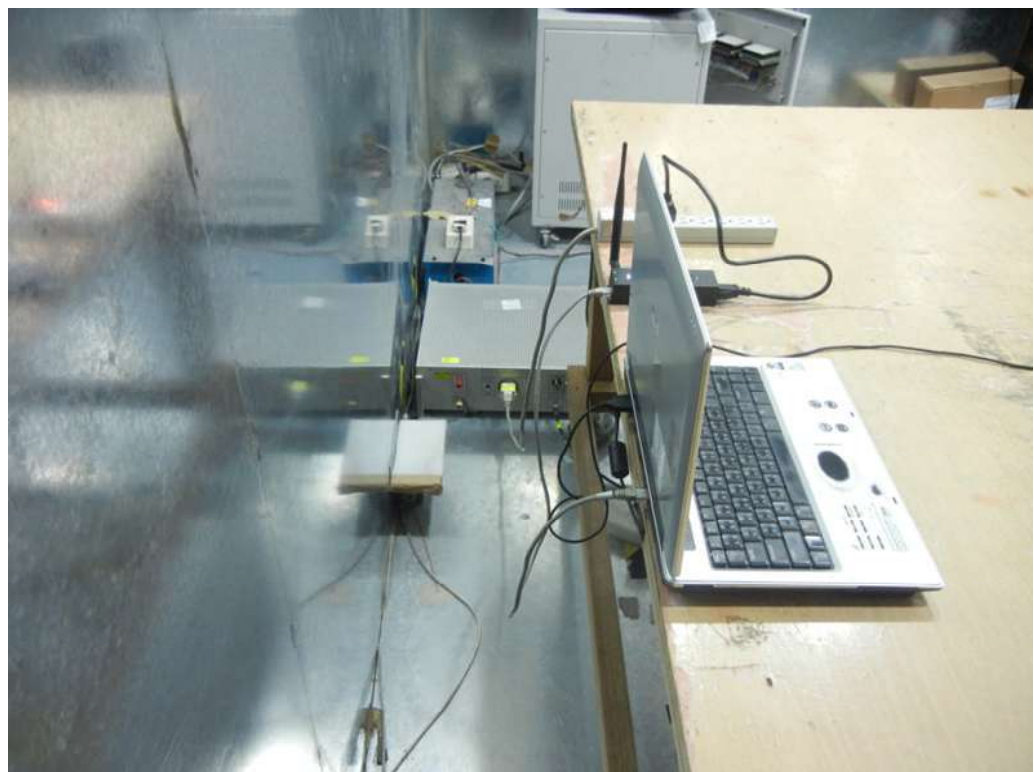



5. Test of Radiated Emission

5.1 Test Limit

In any 100kHz bandwidth outside the frequency band in which the spread spectrum or digitally modulated intentional radiator is operating, the radio frequency power that is produced by the intentional radiator shall be at least 20dB below that in the 100kHz bandwidth within the band that contains the highest level of the desired power, based on either an RF conducted or a radiated measurement. If the transmitter measurement is based on the maximum conducted output power, the attenuation required under this paragraph shall be 30dB instead of 20dB. In addition, radiated emissions which fall in section 15.205(a) the restricted bands must also comply with the radiated emission limit specified in section 15.209(a).

Frequency (MHz)	Field Strength (microvolt/meter)	Measurement Distance (meters)
0.009 ~ 0.490	2400/F(kHz)	300
0.490 ~ 1.705	24000/F(kHz)	30
1.705 ~ 30.0	30	30
30 ~ 88	100	3
88 ~ 216	150	3
216 ~ 960	200	3
Above 960	500	3

5.2 Test Procedures

- The EUT was placed on a rotatable table top 0.8 meter above ground.
- The EUT was set 3 meters from the interference receiving antenna which was mounted on the top of a variable height antenna tower.
- The table was rotated 360 degrees to determine the position of the highest radiation.
- The antenna is a broadband antenna and its height is varied between one meter and four meters above ground to find the maximum value of the field strength both horizontal polarization and vertical polarization of the antenna are set to make the measurement.
- For each suspected emission the EUT was arranged to its worst case and then tune the antenna tower (from 1 M to 4 M) and turn table (from 0 degree to 360 degrees) to find the maximum reading.
- Set the test-receiver system to Peak or CISPR quasi-peak Detect Function and specified bandwidth with Maximum Hold Mode.
- If the emission level of the EUT in peak mode was 3 dB lower than the limit specified, then testing will be stopped and peak values of EUT will be reported, otherwise, the emissions which do not have 3 dB margin will be repeated one by one using the quasi-peak method and reported.
- For testing above 1GHz, the emission level of the EUT in peak mode was 20dB lower than average limit (that means the emission level in peak mode also complies with the limit in average mode), then testing will be stopped and peak values of EUT will be reported, otherwise, the emissions will be measured in average mode again and reported.
- "Cone of radiation" has been considered to be 3dB bandwidth of the measurement antenna.



5.3 Typical Test Setup

For radiated emissions below 30MHz

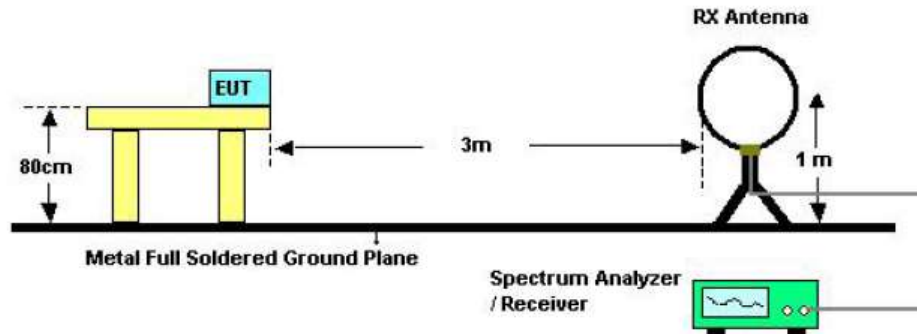

For radiated emissions above 30MHz

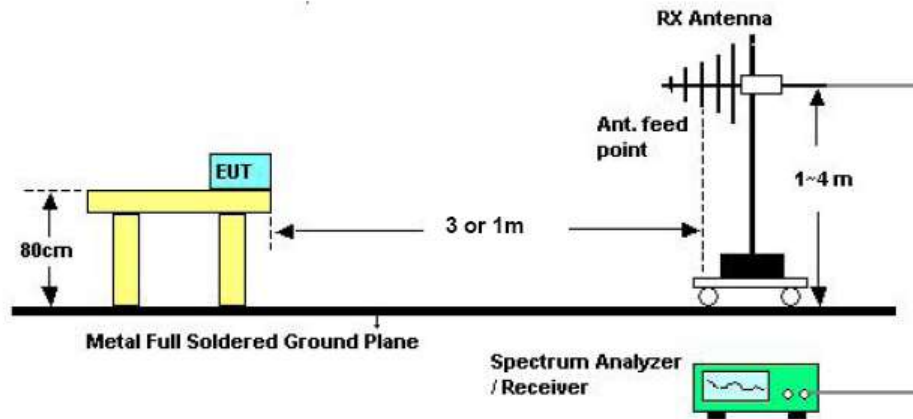

Above 10 GHz shall be extrapolated to the specified distance using an extrapolation factor of 20 dB/decade from 3m to 1m.
 Distance extrapolation factor = $20 \log(\text{specific distance [3m]} / \text{test distance [1m]})$ (dB);
 Limit line = specific limits (dBuV) + distance extrapolation factor [9.54 dB].

5.4 Measurement Equipment

Instrument/Ancillary	Manufacturer	Model No.	Serial No.	Calibration Date	Valid Date
Bilog Antenna	SCHAFFNER	CBL 6112B	2840	2013/03/27	2014/03/26
Amplifier	AGILENT	8447D	2944A10593	2013/03/13	2014/03/12
Spectrum Analyzer	ROHDE & SCHWARZ	FSP 3	100800	2013/03/14	2014/03/13
EMI Measuring Receiver	SCHAFFNER	SCR 3501	437	2013/03/15	2014/03/14
Spectrum Analyzer	R&S	ESCI	100443	2013/01/15	2014/01/14
Horn Antenna	Schwarzbeck	VULB 9168	369	2013/03/06	2014/03/05
Preamplifier	QuieTek	AP/0100A	CHM0906075	2013/01/15	2014/01/14
Loop Antenna	EMCO	6507	40855	N/A	N/A

5.5 Test Result and Data (9kHz ~ 30MHz)

The 9kHz - 30MHz spurious emission is under limit 20dB more.



5.6 Test Result and Data

Power	: AC 120V	Pol/Phase	: VERTICAL
Modulation Type	: 802.11g	Temperature	: 25 °C
Operation Channel	: 1	Humidity	: 59 %
Test Date	: Nov. 07, 2013	Atmospheric Pressure	: 1019 hPa

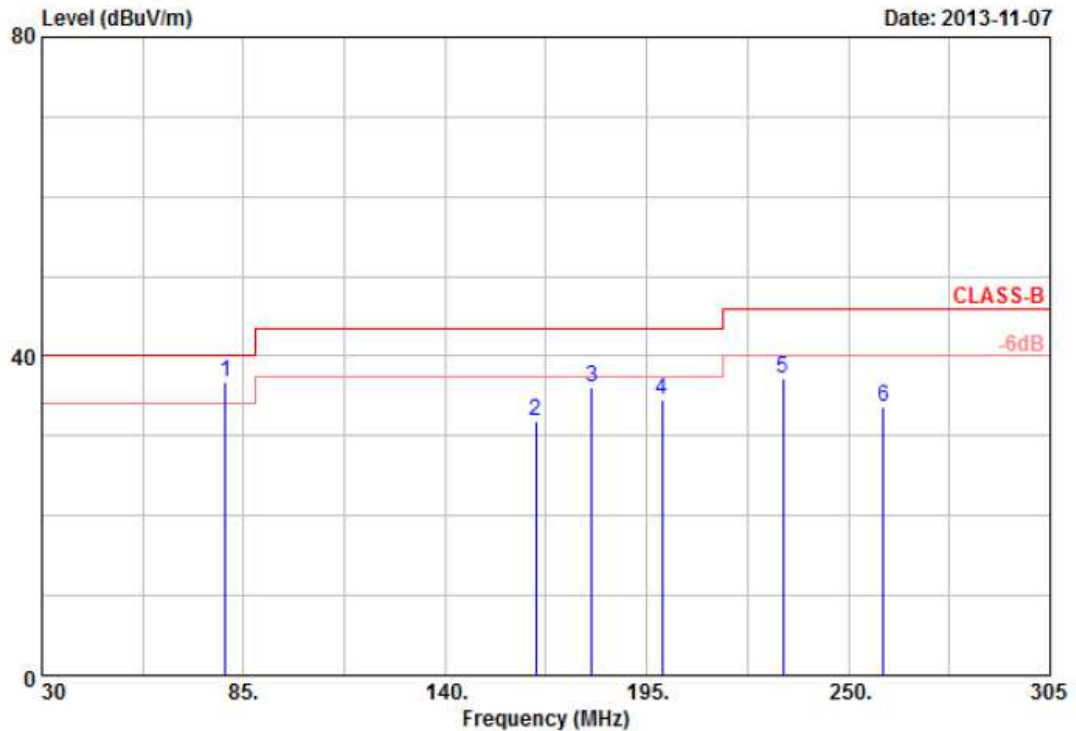

Item	Freq	Read Value	Factor	Result	Limit	Margin	Remark	Ant Pos	Tab Pos
	MHz	dBuV	dB/m	dBuV/m	dBuV/m	dB		cm	Deg
1	80.05	44.26	-7.44	36.82	40.00	-3.18	QP	100	360
2	164.75	41.29	-9.40	31.89	43.50	-11.61	Peak	100	360
3	179.88	41.26	-5.06	36.20	43.50	-7.30	Peak	100	360
4	199.13	46.00	-11.47	34.53	43.50	-8.97	Peak	100	360
5	232.13	44.94	-7.84	37.10	46.00	-8.90	Peak	100	360
6	259.63	41.40	-7.81	33.59	46.00	-12.41	Peak	100	360

Notes:

1. Result = Read Value + Factor
2. Factor = Antenna Factor + Cable Loss - Amplifier
3. The resolution bandwidth of test receiver/spectrum analyzer is 120KHz and video bandwidth is 300kHz for Peak detection and Quasi-peak detection at frequency below 1GHz.
4. All below 1GHz configurations are pretested among available 802.11b/g/n modes and found that the worst cases are on channel 1 of 802.11g & n20 mode and Channel 3 for n40 mode. Only worst case data concluded above were presented in this test report.
5. The data is worse case.



Power	: AC 120V	Pol/Phase	: VERTICAL
Modulation Type	: 802.11g	Temperature	: 25 °C
Operation Channel	: 1	Humidity	: 59 %
Test Date	: Nov. 07, 2013	Atmospheric Pressure	: 1019 hPa

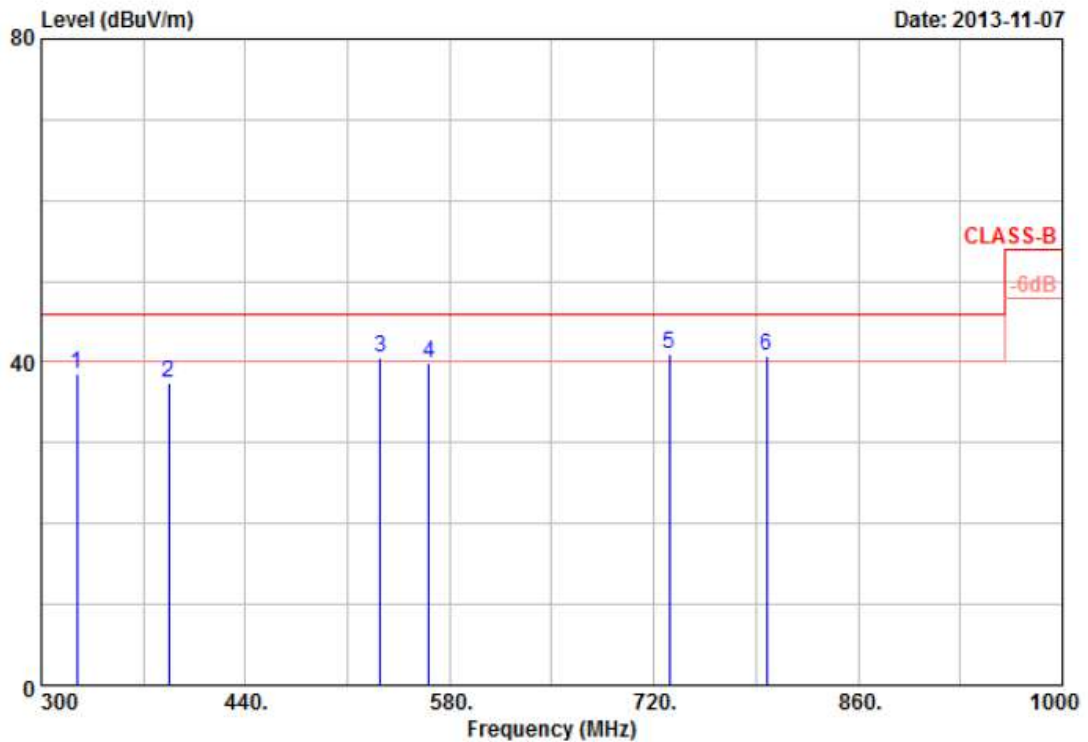

Item	Freq	Read Value	Factor	Result	Limit	Margin	Remark	Ant Pos	Tab Pos
	MHz	dBuV	dB/m	dBuV/m	dBuV/m	dB		cm	Deg
1	324.50	48.20	-9.60	38.60	46.00	-7.40	Peak	100	0
2	387.50	44.34	-6.98	37.36	46.00	-8.64	Peak	100	0
3	532.40	38.30	2.23	40.53	46.00	-5.47	QP	100	0
4	566.00	33.18	6.78	39.96	46.00	-6.04	Peak	100	0
5	730.50	33.75	7.18	40.93	46.00	-5.07	QP	100	0
6	797.00	34.95	5.94	40.89	46.00	-5.11	QP	100	0

Notes:

1. Result = Read Value + Factor
2. Factor = Antenna Factor + Cable Loss - Amplifier
3. The resolution bandwidth of test receiver/spectrum analyzer is 120KHz and video bandwidth is 300kHz for Peak detection and Quasi-peak detection at frequency below 1GHz.
4. All below 1GHz configurations are pretested among available 802.11b/g/n modes and found that the worst cases are on channel 1 of 802.11g & n20 mode and Channel 3 for n40 mode. Only worst case data concluded above were presented in this test report.
5. The data is worse case.



Power	: AC 120V	Pol/Phase	: HORIZONTAL
Modulation Type	: 802.11g	Temperature	: 25 °C
Operation Channel	: 1	Humidity	: 59 %
Test Date	: Nov. 07, 2013	Atmospheric Pressure	: 1019 hPa

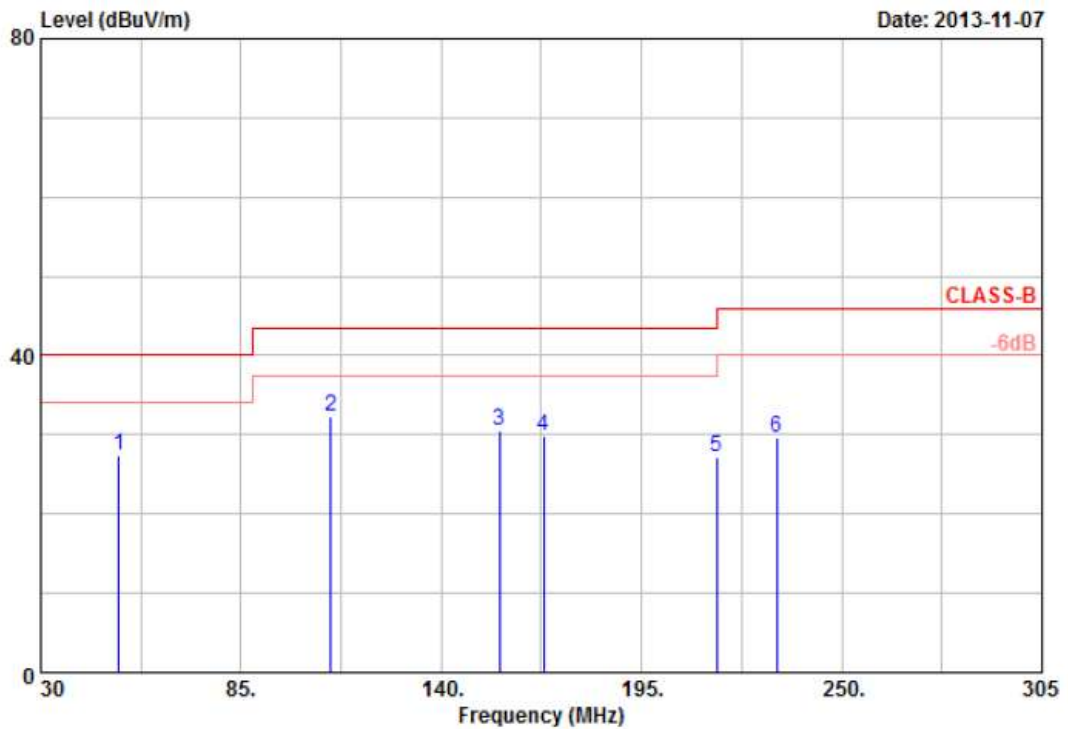

Item	Freq	Read Value	Factor	Result	Limit	Margin	Remark	Ant Pos	Tab Pos
	MHz	dBuV	dB/m	dBuV/m	dBuV/m	dB		cm	Deg
1	51.45	37.15	-9.82	27.33	40.00	-12.67	Peak	100	360
2	109.75	51.31	-18.93	32.38	43.50	-11.12	Peak	100	360
3	155.95	46.50	-15.93	30.57	43.50	-12.93	Peak	100	360
4	168.05	42.97	-13.07	29.90	43.50	-13.60	Peak	100	360
5	215.63	43.46	-16.31	27.15	43.50	-16.35	Peak	100	360
6	232.13	44.42	-14.72	29.70	46.00	-16.30	Peak	100	360

Notes:

1. Result = Read Value + Factor
2. Factor = Antenna Factor + Cable Loss - Amplifier
3. The resolution bandwidth of test receiver/spectrum analyzer is 120KHz and video bandwidth is 300kHz for Peak detection and Quasi-peak detection at frequency below 1GHz.
4. All below 1GHz configurations are pretested among available 802.11b/g/n modes and found that the worst cases are on channel 1 of 802.11g & n20 mode and Channel 3 for n40 mode. Only worst case data concluded above were presented in this test report.
5. The data is worse case.



Power	: AC 120V	Pol/Phase	: HORIZONTAL
Modulation Type	: 802.11g	Temperature	: 25 °C
Operation Channel	: 1	Humidity	: 59 %
Test Date	: Nov. 07, 2013	Atmospheric Pressure	: 1019 hPa

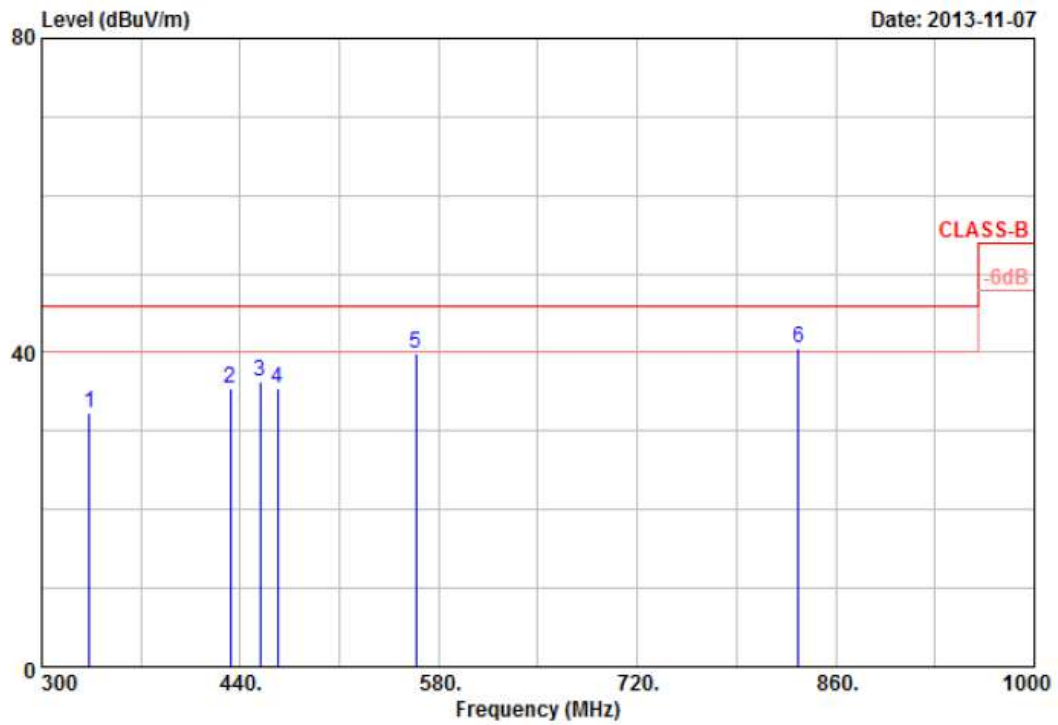

Item	Freq	Read Value	Factor	Result	Limit	Margin	Remark	Ant Pos	Tab Pos
	MHz	dBuV	dB/m	dBuV/m	dBuV/m	dB		cm	Deg
1	333.60	42.19	-9.90	32.29	46.00	-13.71	Peak	100	0
2	433.00	42.31	-6.94	35.37	46.00	-10.63	Peak	100	0
3	454.00	40.89	-4.67	36.22	46.00	-9.78	Peak	100	0
4	466.60	40.47	-5.06	35.41	46.00	-10.59	Peak	100	0
5	563.90	37.69	2.09	39.78	46.00	-6.22	Peak	100	0
6	833.40	31.70	8.80	40.50	46.00	-5.50	QP	100	0

Notes:

1. Result = Read Value + Factor
2. Factor = Antenna Factor + Cable Loss - Amplifier
3. The resolution bandwidth of test receiver/spectrum analyzer is 120KHz and video bandwidth is 300kHz for Peak detection and Quasi-peak detection at frequency below 1GHz.
4. All below 1GHz configurations are pretested among available 802.11b/g/n modes and found that the worst cases are on channel 1 of 802.11g & n20 mode and Channel 3 for n40 mode. Only worst case data concluded above were presented in this test report.
5. The data is worse case.



Power	: AC 120V	Pol/Phase	: VERTICAL
Modulation Type	: 802.11b	Temperature	: 25 °C
Operation Channel	: 1	Humidity	: 56 %
Test Date	: Nov. 08, 2013	Atmospheric Pressure	: 1018 hPa

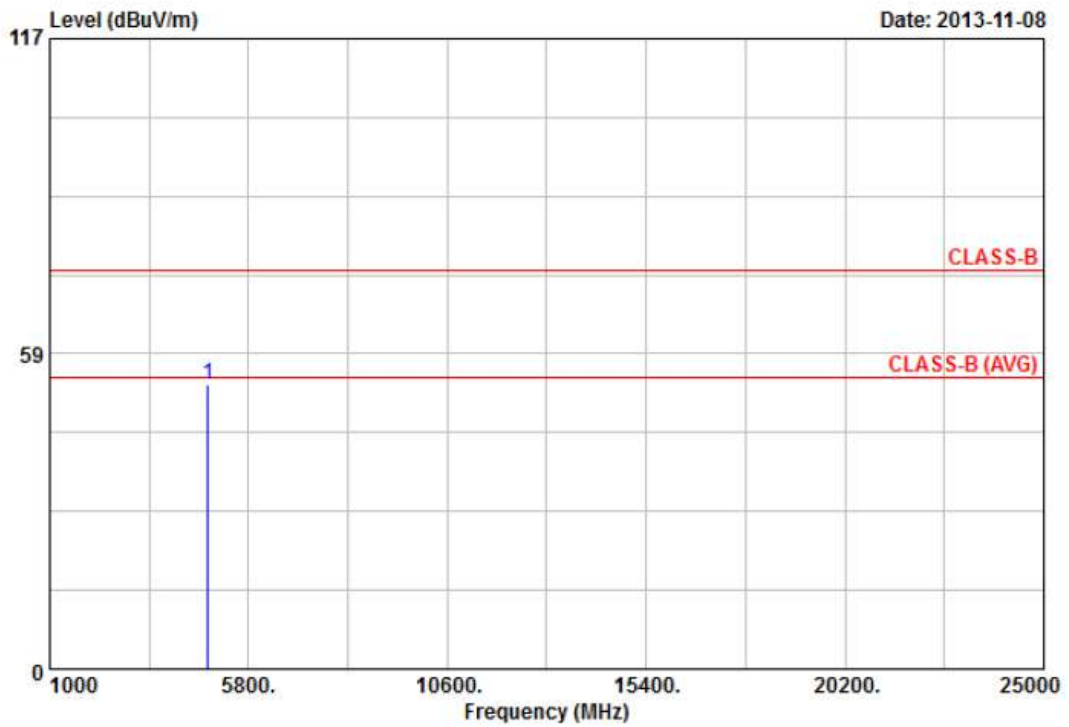

Item	Freq	Read Value	Factor	Result	Limit	Margin	Remark	Ant Pos	Tab Pos
	MHz	dBuV	dB/m	dBuV/m	dBuV/m	dB		cm	Deg
1	4825.38	47.25	5.70	52.95	74.00	-21.05	Peak	100	195

Notes:

1. Result = Read Value + Factor
2. Factor = Antenna Factor + Cable Loss - Amplifier
3. The resolution bandwidth of test receiver/spectrum analyzer is 120KHz and video bandwidth is 300kHz for Peak detection and Quasi-peak detection at frequency below 1GHz.
4. The resolution bandwidth of test receiver/spectrum analyzer is 1MHz and video bandwidth is 3MHz for Peak detection at frequency above 1GHz.
5. The resolution bandwidth of test receiver/spectrum analyzer is 1MHz and video bandwidth is 3MHz (detector sample mode) for Average detection at frequency above 1GHz.
6. The other emissions is too low to be measured. (The worst case noise floor measurements value is 47.93 dBuV at 16.10GHz)
7. The data is worse case.



Power	: AC 120V	Pol/Phase	: HORIZONTAL
Modulation Type	: 802.11b	Temperature	: 25 °C
Operation Channel	: 1	Humidity	: 56 %
Test Date	: Nov. 08, 2013	Atmospheric Pressure	: 1018 hPa

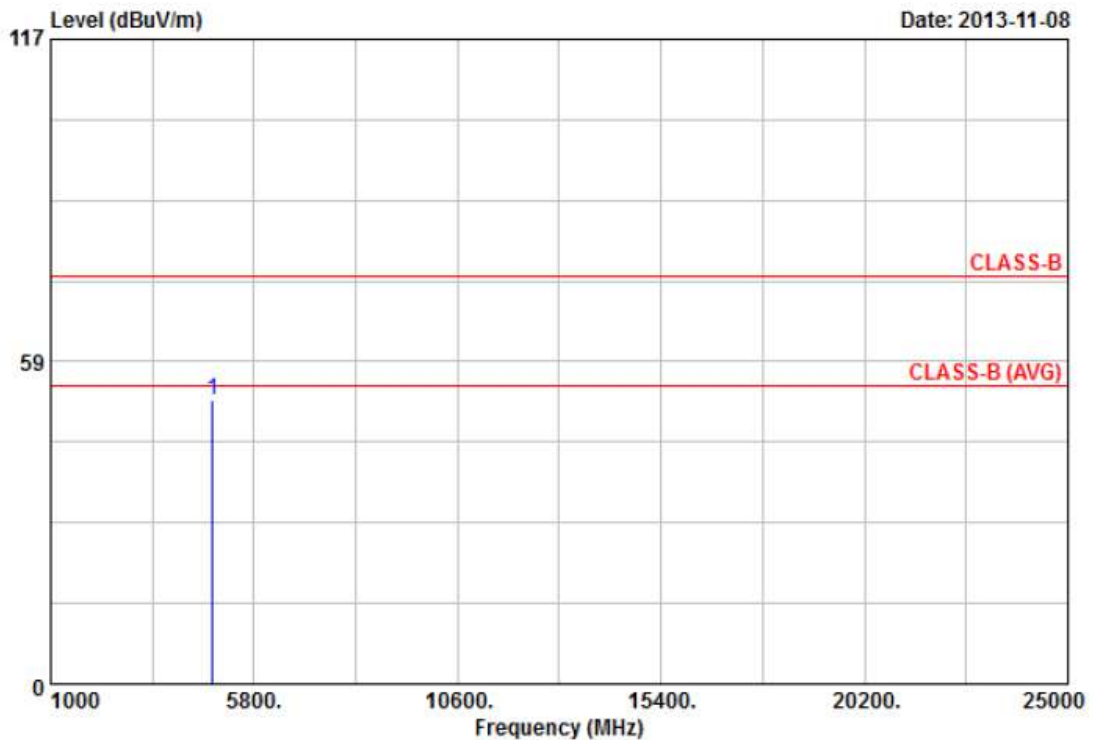

Item	Freq	Read Value	Factor	Result	Limit	Margin	Remark	Ant Pos	Tab Pos
	MHz	dBuV	dB/m	dBuV/m	dBuV/m	dB		cm	Deg
1	4819.75	47.56	3.94	51.50	74.00	-22.50	Peak	100	195

Notes:

1. Result = Read Value + Factor
2. Factor = Antenna Factor + Cable Loss - Amplifier
3. The resolution bandwidth of test receiver/spectrum analyzer is 120KHz and video bandwidth is 300kHz for Peak detection and Quasi-peak detection at frequency below 1GHz.
4. The resolution bandwidth of test receiver/spectrum analyzer is 1MHz and video bandwidth is 3MHz for Peak detection at frequency above 1GHz.
5. The resolution bandwidth of test receiver/spectrum analyzer is 1MHz and video bandwidth is 3MHz (detector sample mode) for Average detection at frequency above 1GHz.
6. The other emissions is too low to be measured. (The worst case noise floor measurements value is 47.93 dBuV at 16.10GHz)
7. The data is worse case.



Power	: AC 120V	Pol/Phase	: VERTICAL
Modulation Type	: 802.11b	Temperature	: 25 °C
Operation Channel	: 6	Humidity	: 56 %
Test Date	: Nov. 08, 2013	Atmospheric Pressure	: 1018 hPa

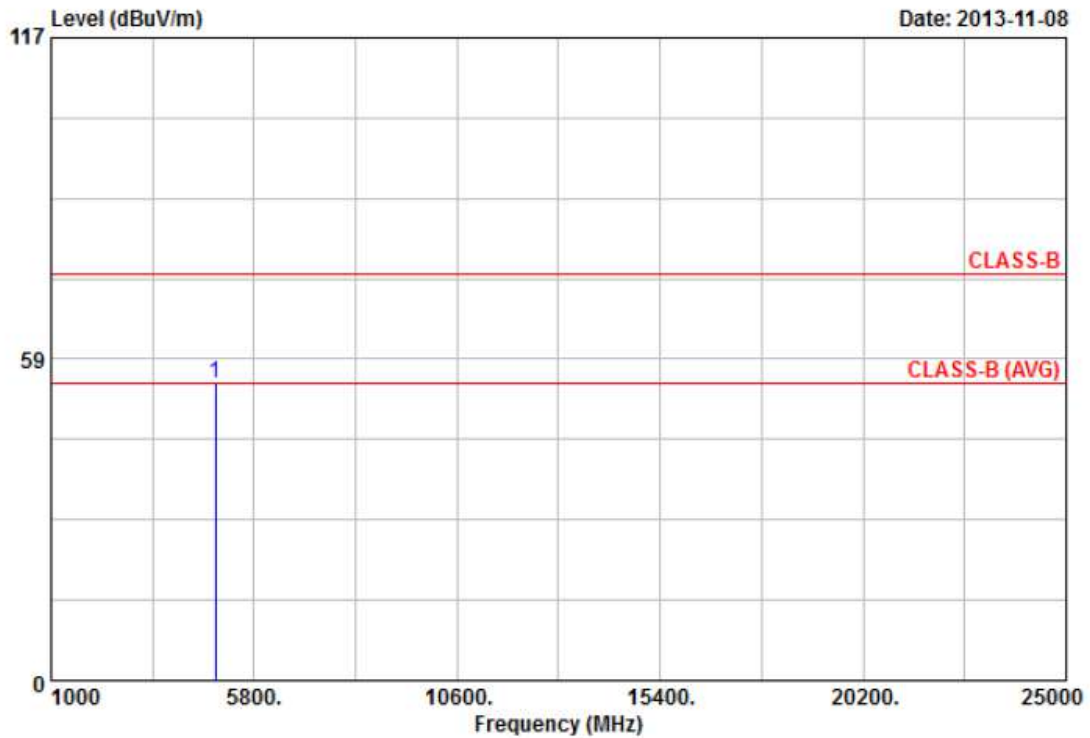

Item	Freq	Read Value	Factor	Result	Limit	Margin	Remark	Ant Pos	Tab Pos
	MHz	dBuV	dB/m	dBuV/m	dBuV/m	dB		cm	Deg
1	4873.95	47.33	6.65	53.98	74.00	-20.02	Peak	100	196

Notes:

1. Result = Read Value + Factor
2. Factor = Antenna Factor + Cable Loss - Amplifier
3. The resolution bandwidth of test receiver/spectrum analyzer is 120KHz and video bandwidth is 300kHz for Peak detection and Quasi-peak detection at frequency below 1GHz.
4. The resolution bandwidth of test receiver/spectrum analyzer is 1MHz and video bandwidth is 3MHz for Peak detection at frequency above 1GHz.
5. The resolution bandwidth of test receiver/spectrum analyzer is 1MHz and video bandwidth is 3MHz (detector sample mode) for Average detection at frequency above 1GHz.
6. The other emissions is too low to be measured. (The worst case noise floor measurements value is 47.93 dBuV at 16.10GHz)
7. The data is worse case.



Power	: AC 120V	Pol/Phase	: HORIZONTAL
Modulation Type	: 802.11b	Temperature	: 25 °C
Operation Channel	: 6	Humidity	: 56 %
Test Date	: Nov. 08, 2013	Atmospheric Pressure	: 1018 hPa

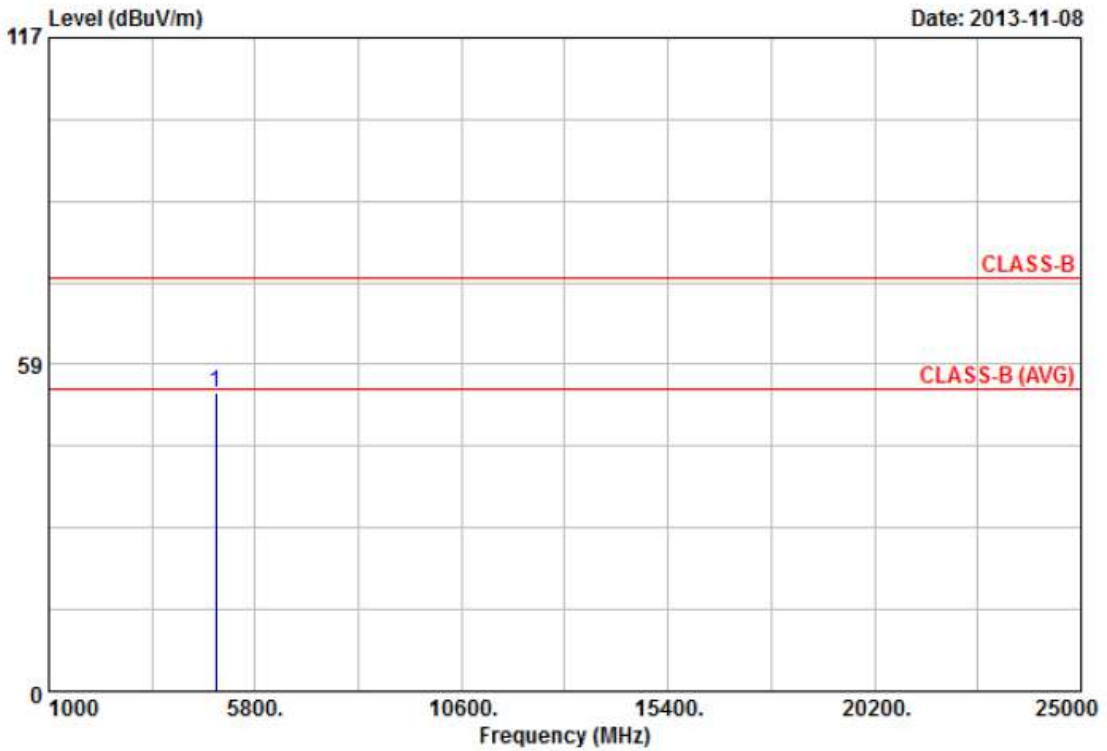

Item	Freq	Read Value	Factor	Result	Limit	Margin	Remark	Ant Pos	Tab Pos
	MHz	dBuV	dB/m	dBuV/m	dBuV/m	dB		cm	Deg
1	4873.95	48.59	4.79	53.38	74.00	-20.62	Peak	100	196

Notes:

1. Result = Read Value + Factor
2. Factor = Antenna Factor + Cable Loss - Amplifier
3. The resolution bandwidth of test receiver/spectrum analyzer is 120KHz and video bandwidth is 300kHz for Peak detection and Quasi-peak detection at frequency below 1GHz.
4. The resolution bandwidth of test receiver/spectrum analyzer is 1MHz and video bandwidth is 3MHz for Peak detection at frequency above 1GHz.
5. The resolution bandwidth of test receiver/spectrum analyzer is 1MHz and video bandwidth is 3MHz (detector sample mode) for Average detection at frequency above 1GHz.
6. The other emissions is too low to be measured. (The worst case noise floor measurements value is 47.93 dBuV at 16.10GHz)
7. The data is worse case.



Power	: AC 120V	Pol/Phase	: VERTICAL
Modulation Type	: 802.11b	Temperature	: 25 °C
Operation Channel	: 11	Humidity	: 56 %
Test Date	: Nov. 08, 2013	Atmospheric Pressure	: 1018 hPa

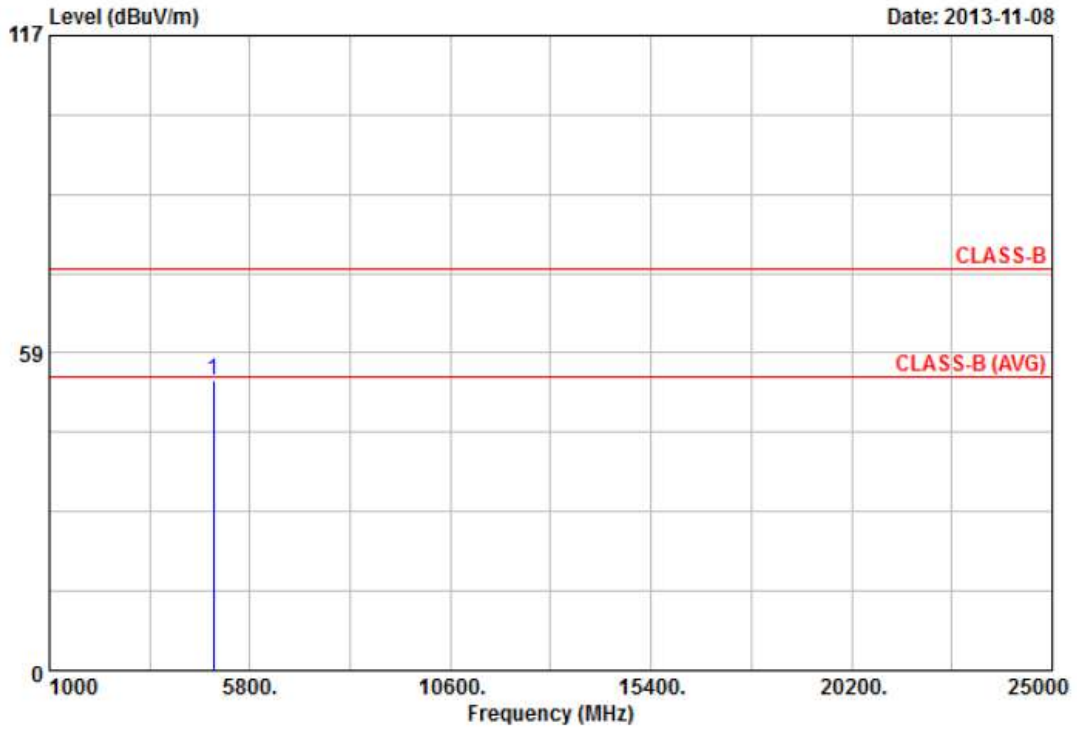

Item	Freq	Read Value	Factor	Result	Limit	Margin	Remark	Ant Pos	Tab Pos
	MHz	dBuV	dB/m	dBuV/m	dBuV/m	dB		cm	Deg
1	4924.10	46.22	7.21	53.43	74.00	-20.57	Peak	100	196

Notes:

1. Result = Read Value + Factor
2. Factor = Antenna Factor + Cable Loss - Amplifier
3. The resolution bandwidth of test receiver/spectrum analyzer is 120KHz and video bandwidth is 300kHz for Peak detection and Quasi-peak detection at frequency below 1GHz.
4. The resolution bandwidth of test receiver/spectrum analyzer is 1MHz and video bandwidth is 3MHz for Peak detection at frequency above 1GHz.
5. The resolution bandwidth of test receiver/spectrum analyzer is 1MHz and video bandwidth is 3MHz (detector sample mode) for Average detection at frequency above 1GHz.
6. The other emissions is too low to be measured. (The worst case noise floor measurements value is 47.93 dBuV at 16.10GHz)
7. The data is worse case.



Power	: AC 120V	Pol/Phase	: HORIZONTAL
Modulation Type	: 802.11b	Temperature	: 25 °C
Operation Channel	: 11	Humidity	: 56 %
Test Date	: Nov. 08, 2013	Atmospheric Pressure	: 1018 hPa

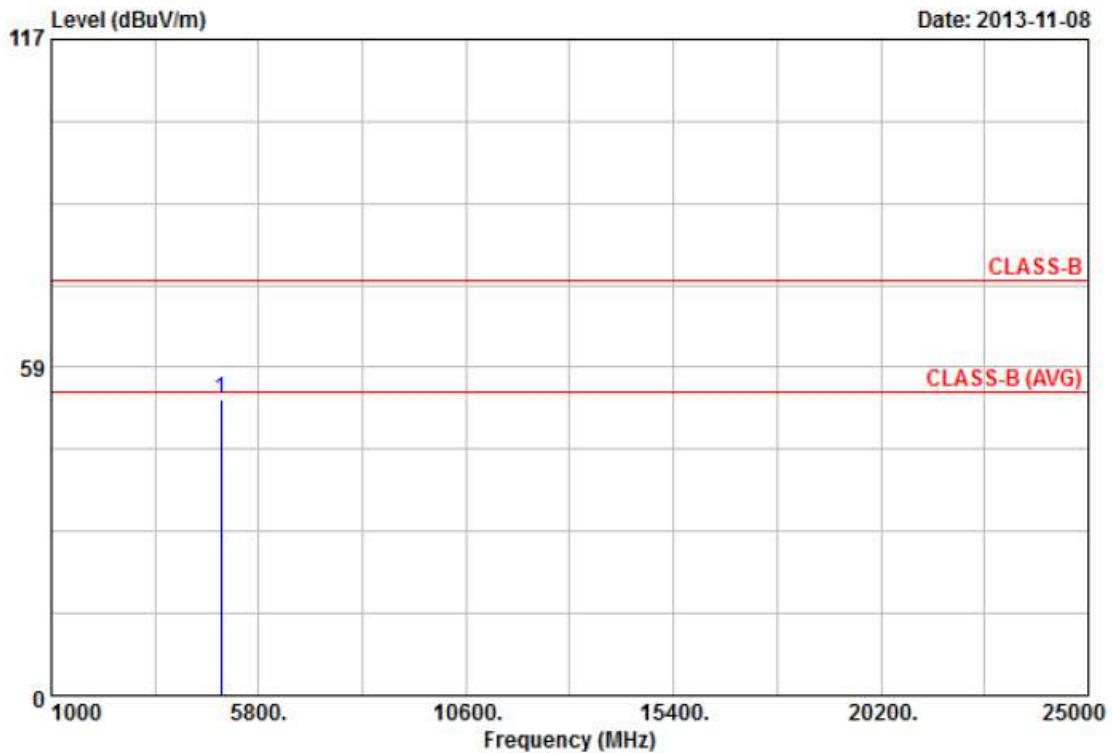

Item	Freq	Read Value	Factor	Result	Limit	Margin	Remark	Ant Pos	Tab Pos
	MHz	dBuV	dB/m	dBuV/m	dBuV/m	dB		cm	Deg
1	4927.18	47.54	5.21	52.75	74.00	-21.25	Peak	100	196

Notes:

1. Result = Read Value + Factor
2. Factor = Antenna Factor + Cable Loss - Amplifier
3. The resolution bandwidth of test receiver/spectrum analyzer is 120KHz and video bandwidth is 300kHz for Peak detection and Quasi-peak detection at frequency below 1GHz.
4. The resolution bandwidth of test receiver/spectrum analyzer is 1MHz and video bandwidth is 3MHz for Peak detection at frequency above 1GHz.
5. The resolution bandwidth of test receiver/spectrum analyzer is 1MHz and video bandwidth is 3MHz (detector sample mode) for Average detection at frequency above 1GHz.
6. The other emissions is too low to be measured. (The worst case noise floor measurements value is 47.93 dBuV at 16.10GHz)
7. The data is worse case.



Power	: AC 120V	Pol/Phase	: VERTICAL
Modulation Type	: 802.11g	Temperature	: 25 °C
Operation Channel	: 1	Humidity	: 56 %
Test Date	: Nov. 08, 2013	Atmospheric Pressure	: 1018 hPa

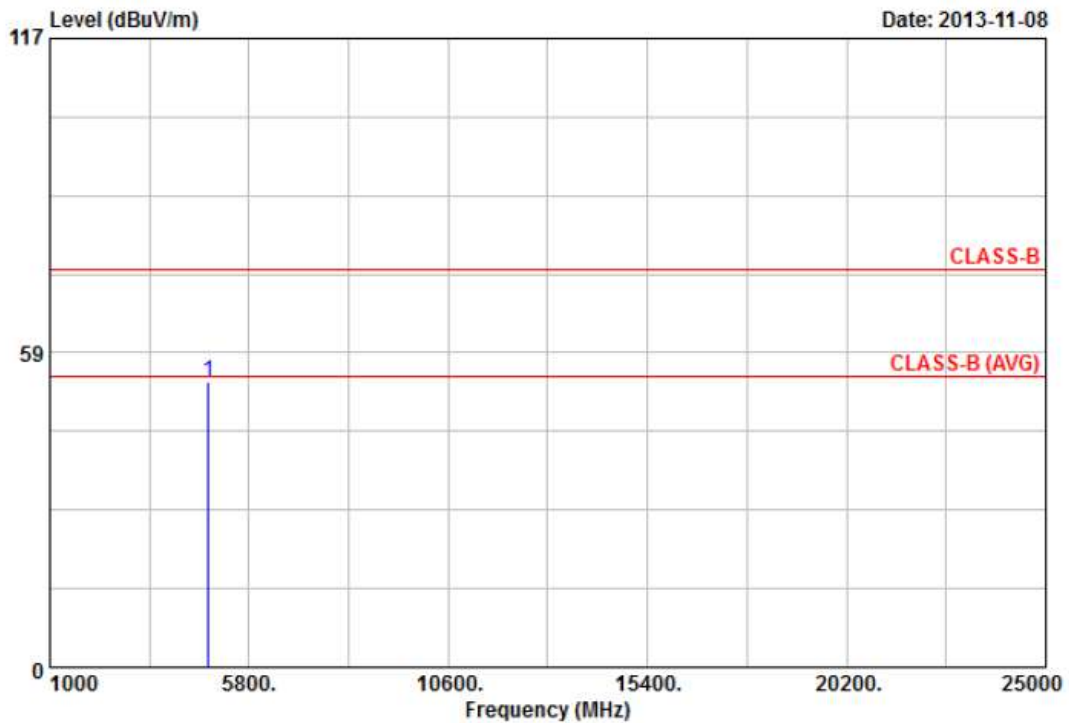

Item	Freq	Read Value	Factor	Result	Limit	Margin	Remark	Ant Pos	Tab Pos
	MHz	dBuV	dB/m	dBuV/m	dBuV/m	dB		cm	Deg
1	4828.40	47.36	5.75	53.11	74.00	-20.89	Peak	100	196

Notes:

1. Result = Read Value + Factor
2. Factor = Antenna Factor + Cable Loss - Amplifier
3. The resolution bandwidth of test receiver/spectrum analyzer is 120KHz and video bandwidth is 300kHz for Peak detection and Quasi-peak detection at frequency below 1GHz.
4. The resolution bandwidth of test receiver/spectrum analyzer is 1MHz and video bandwidth is 3MHz for Peak detection at frequency above 1GHz.
5. The resolution bandwidth of test receiver/spectrum analyzer is 1MHz and video bandwidth is 3MHz (detector sample mode) for Average detection at frequency above 1GHz.
6. The other emissions is too low to be measured. (The worst case noise floor measurements value is 47.93 dBuV at 16.10GHz)
7. The data is worse case.



Power	: AC 120V	Pol/Phase	: HORIZONTAL
Modulation Type	: 802.11g	Temperature	: 25 °C
Operation Channel	: 1	Humidity	: 56 %
Test Date	: Nov. 08, 2013	Atmospheric Pressure	: 1018 hPa

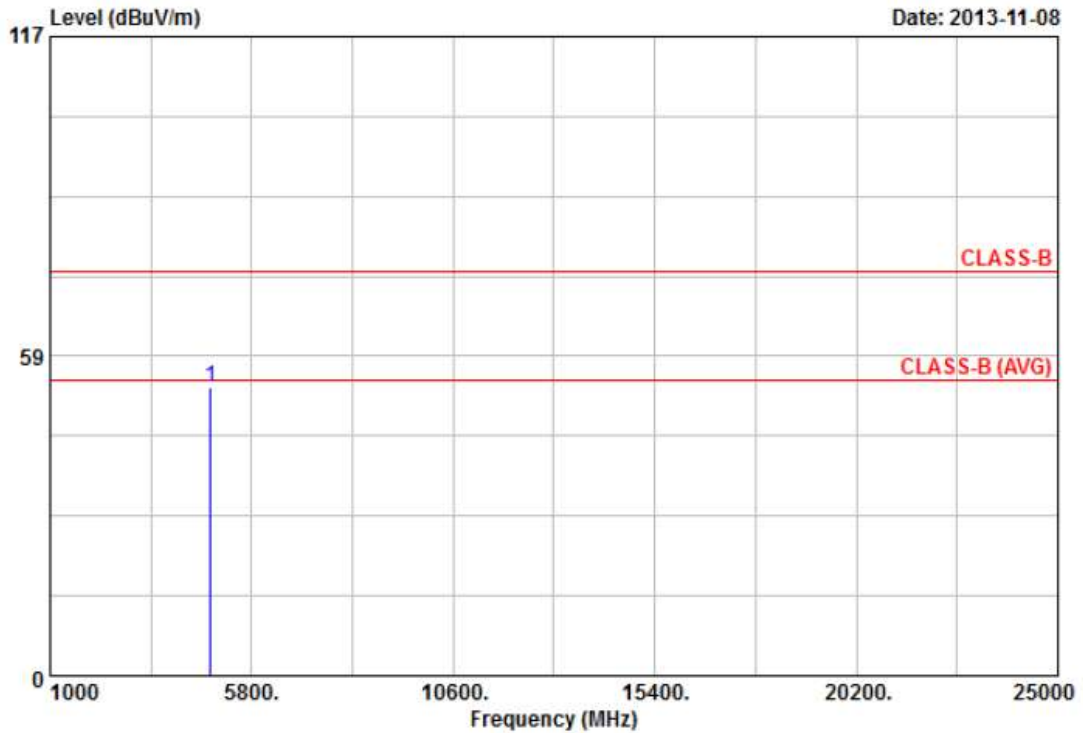

Item	Freq	Read Value	Factor	Result	Limit	Margin	Remark	Ant Pos	Tab Pos
	MHz	dBuV	dB/m	dBuV/m	dBuV/m	dB		cm	Deg
1	4823.05	48.67	3.99	52.66	74.00	-21.34	Peak	100	196

Notes:

1. Result = Read Value + Factor
2. Factor = Antenna Factor + Cable Loss - Amplifier
3. The resolution bandwidth of test receiver/spectrum analyzer is 120KHz and video bandwidth is 300kHz for Peak detection and Quasi-peak detection at frequency below 1GHz.
4. The resolution bandwidth of test receiver/spectrum analyzer is 1MHz and video bandwidth is 3MHz for Peak detection at frequency above 1GHz.
5. The resolution bandwidth of test receiver/spectrum analyzer is 1MHz and video bandwidth is 3MHz (detector sample mode) for Average detection at frequency above 1GHz.
6. The other emissions is too low to be measured. (The worst case noise floor measurements value is 47.93 dBuV at 16.10GHz)
7. The data is worse case.



Power	: AC 120V	Pol/Phase	: VERTICAL
Modulation Type	: 802.11g	Temperature	: 25 °C
Operation Channel	: 6	Humidity	: 56 %
Test Date	: Nov. 08, 2013	Atmospheric Pressure	: 1018 hPa

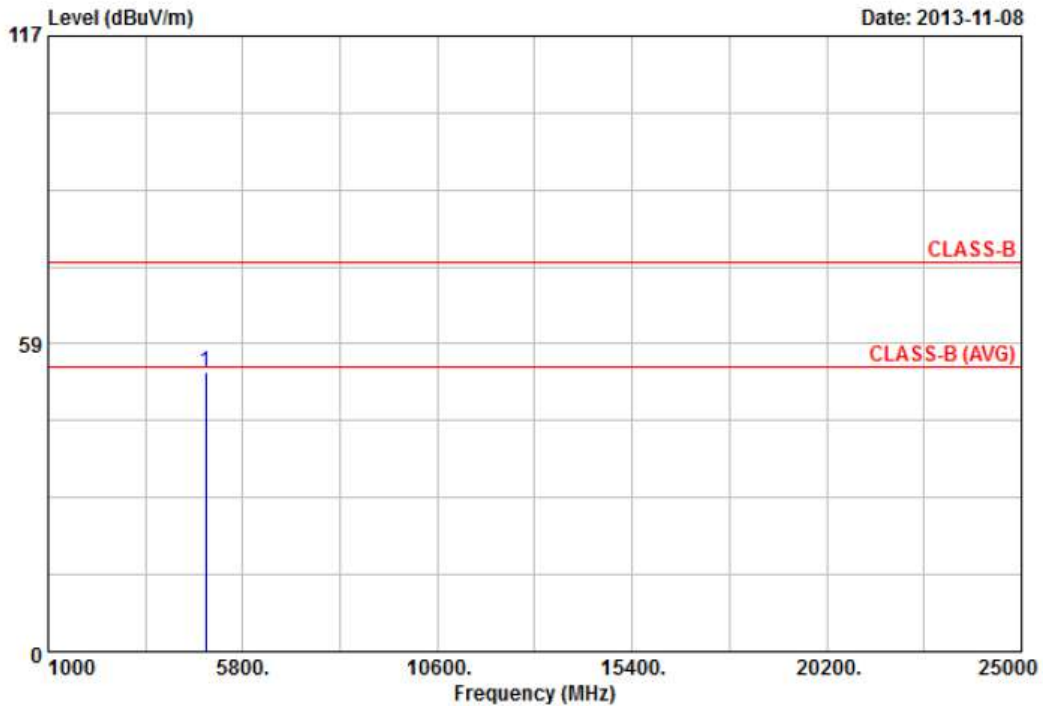

Item	Freq	Read Value	Factor	Result	Limit	Margin	Remark	Ant Pos	Tab Pos
	MHz	dBuV	dB/m	dBuV/m	dBuV/m	dB		cm	Deg
1	4873.40	46.63	6.64	53.27	74.00	-20.73	Peak	100	196

Notes:

1. Result = Read Value + Factor
2. Factor = Antenna Factor + Cable Loss - Amplifier
3. The resolution bandwidth of test receiver/spectrum analyzer is 120KHz and video bandwidth is 300kHz for Peak detection and Quasi-peak detection at frequency below 1GHz.
4. The resolution bandwidth of test receiver/spectrum analyzer is 1MHz and video bandwidth is 3MHz for Peak detection at frequency above 1GHz.
5. The resolution bandwidth of test receiver/spectrum analyzer is 1MHz and video bandwidth is 3MHz (detector sample mode) for Average detection at frequency above 1GHz.
6. The other emissions is too low to be measured. (The worst case noise floor measurements value is 47.93 dBuV at 16.10GHz)
7. The data is worse case.



Power	: AC 120V	Pol/Phase	: HORIZONTAL
Modulation Type	: 802.11g	Temperature	: 25 °C
Operation Channel	: 6	Humidity	: 56 %
Test Date	: Nov. 08, 2013	Atmospheric Pressure	: 1018 hPa

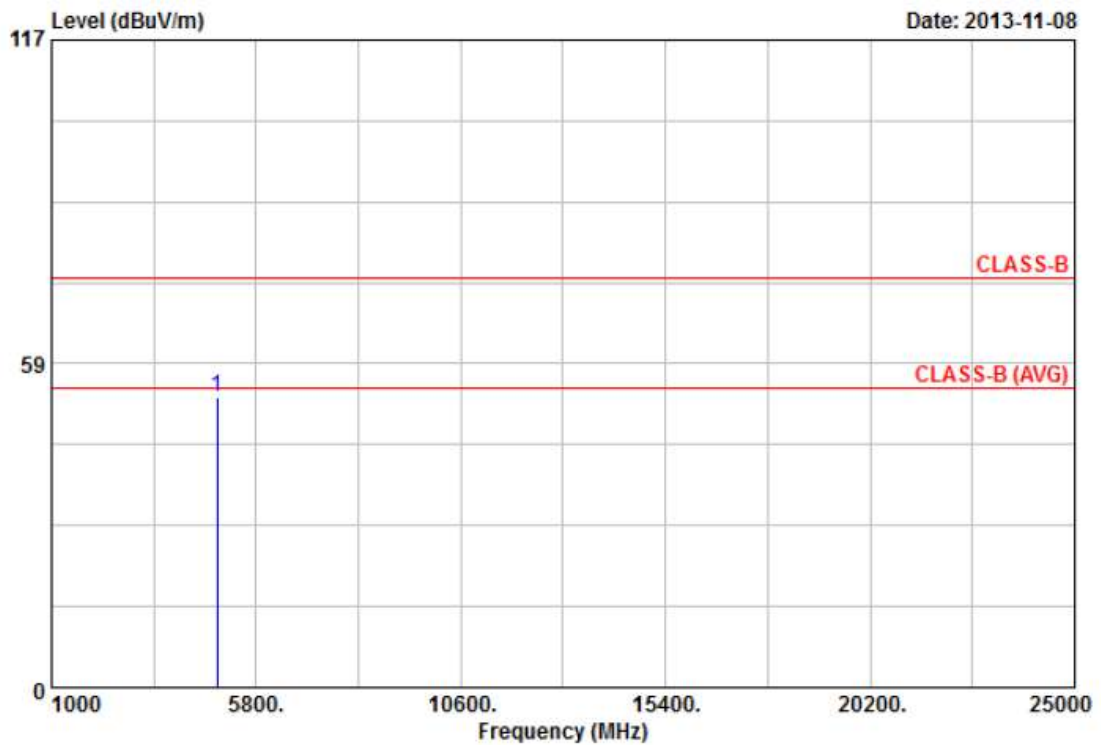

Item	Freq	Read Value	Factor	Result	Limit	Margin	Remark	Ant Pos	Tab Pos
	MHz	dBuV	dB/m	dBuV/m	dBuV/m	dB		cm	Deg
1	4873.28	47.74	4.78	52.52	74.00	-21.48	Peak	100	196

Notes:

1. Result = Read Value + Factor
2. Factor = Antenna Factor + Cable Loss - Amplifier
3. The resolution bandwidth of test receiver/spectrum analyzer is 120KHz and video bandwidth is 300kHz for Peak detection and Quasi-peak detection at frequency below 1GHz.
4. The resolution bandwidth of test receiver/spectrum analyzer is 1MHz and video bandwidth is 3MHz for Peak detection at frequency above 1GHz.
5. The resolution bandwidth of test receiver/spectrum analyzer is 1MHz and video bandwidth is 3MHz (detector sample mode) for Average detection at frequency above 1GHz.
6. The other emissions is too low to be measured. (The worst case noise floor measurements value is 47.93 dBuV at 16.10GHz)
7. The data is worse case.



Power	: AC 120V	Pol/Phase	: VERTICAL
Modulation Type	: 802.11g	Temperature	: 25 °C
Operation Channel	: 11	Humidity	: 56 %
Test Date	: Nov. 08, 2013	Atmospheric Pressure	: 1018 hPa

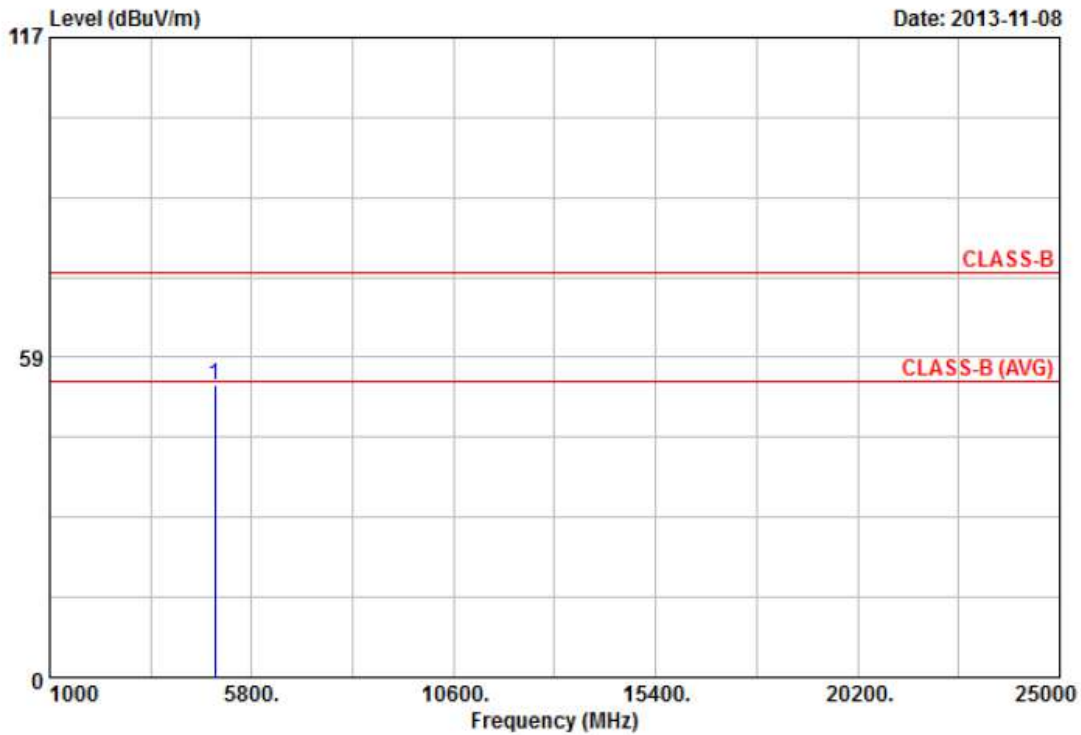

Item	Freq	Read Value	Factor	Result	Limit	Margin	Remark	Ant Pos	Tab Pos
	MHz	dBuV	dB/m	dBuV/m	dBuV/m	dB		cm	Deg
1	4922.10	46.26	7.21	53.47	74.00	-20.53	Peak	100	196

Notes:

1. Result = Read Value + Factor
2. Factor = Antenna Factor + Cable Loss - Amplifier
3. The resolution bandwidth of test receiver/spectrum analyzer is 120KHz and video bandwidth is 300kHz for Peak detection and Quasi-peak detection at frequency below 1GHz.
4. The resolution bandwidth of test receiver/spectrum analyzer is 1MHz and video bandwidth is 3MHz for Peak detection at frequency above 1GHz.
5. The resolution bandwidth of test receiver/spectrum analyzer is 1MHz and video bandwidth is 3MHz (detector sample mode) for Average detection at frequency above 1GHz.
6. The other emissions is too low to be measured. (The worst case noise floor measurements value is 47.93 dBuV at 16.10GHz)
7. The data is worse case.



Power	: AC 120V	Pol/Phase	: HORIZONTAL
Modulation Type	: 802.11g	Temperature	: 25 °C
Operation Channel	: 11	Humidity	: 56 %
Test Date	: Nov. 08, 2013	Atmospheric Pressure	: 1018 hPa

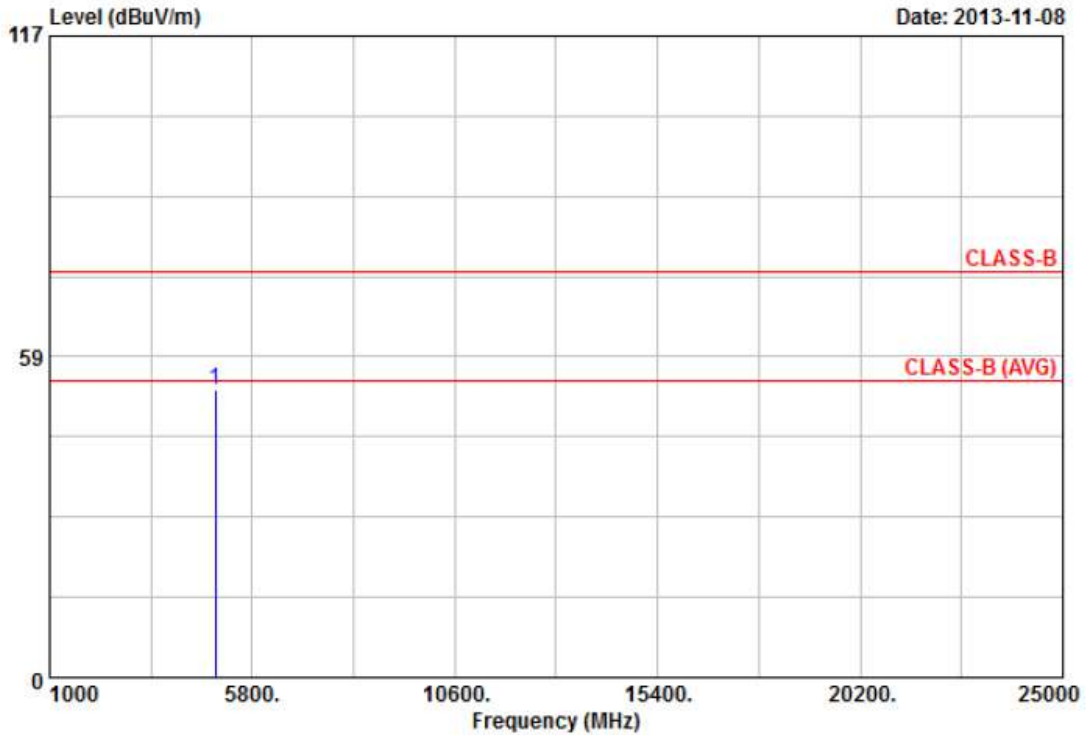

Item	Freq	Read Value	Factor	Result	Limit	Margin	Remark	Ant Pos	Tab Pos
	MHz	dBuV	dB/m	dBuV/m	dBuV/m	dB		cm	Deg
1	4920.75	47.34	5.20	52.54	74.00	-21.46	Peak	100	196

Notes:

1. Result = Read Value + Factor
2. Factor = Antenna Factor + Cable Loss - Amplifier
3. The resolution bandwidth of test receiver/spectrum analyzer is 120KHz and video bandwidth is 300kHz for Peak detection and Quasi-peak detection at frequency below 1GHz.
4. The resolution bandwidth of test receiver/spectrum analyzer is 1MHz and video bandwidth is 3MHz for Peak detection at frequency above 1GHz.
5. The resolution bandwidth of test receiver/spectrum analyzer is 1MHz and video bandwidth is 3MHz (detector sample mode) for Average detection at frequency above 1GHz.
6. The other emissions is too low to be measured. (The worst case noise floor measurements value is 47.93 dBuV at 16.10GHz)
7. The data is worse case.



Power	: AC 120V	Pol/Phase	: VERTICAL
Modulation Type	: 802.11n HT20	Temperature	: 25 °C
Operation Channel	: 1	Humidity	: 59 %
Test Date	: Nov. 07, 2013	Atmospheric Pressure	: 1019 hPa

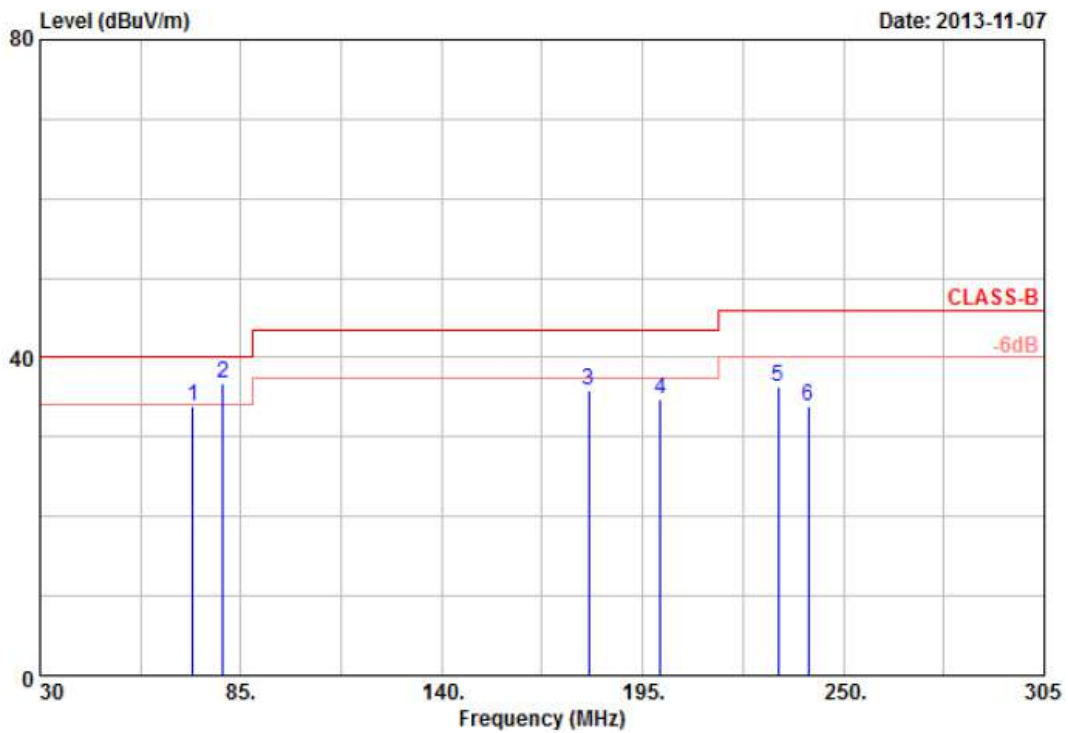

Item	Freq	Read Value	Factor	Result	Limit	Margin	Remark	Ant Pos	Tab Pos
	MHz	dBuV	dB/m	dBuV/m	dBuV/m	dB		cm	Deg
1	71.80	44.35	-10.55	33.80	40.00	-6.20	QP	100	360
2	80.05	44.29	-7.44	36.85	40.00	-3.15	QP	100	360
3	180.15	40.95	-5.15	35.80	43.50	-7.70	Peak	100	360
4	199.95	46.08	-11.42	34.66	43.50	-8.84	Peak	100	360
5	232.13	44.12	-7.84	36.28	46.00	-9.72	Peak	100	360
6	240.38	43.43	-9.51	33.92	46.00	-12.08	Peak	100	360

Notes:

1. Result = Read Value + Factor
2. Factor = Antenna Factor + Cable Loss - Amplifier
3. The resolution bandwidth of test receiver/spectrum analyzer is 120KHz and video bandwidth is 300kHz for Peak detection and Quasi-peak detection at frequency below 1GHz.
4. All below 1GHz configurations are pretested among available 802.11b/g/n modes and found that the worst cases are on channel 1 of 802.11g & n20 mode and Channel 3 for n40 mode. Only worst case data concluded above were presented in this test report.
5. The data is worse case.



Power	: AC 120V	Pol/Phase	: VERTICAL
Modulation Type	: 802.11 n HT20	Temperature	: 25 °C
Operation Channel	: 1	Humidity	: 56 %
Test Date	: Nov. 08, 2013	Atmospheric Pressure	: 1018 hPa

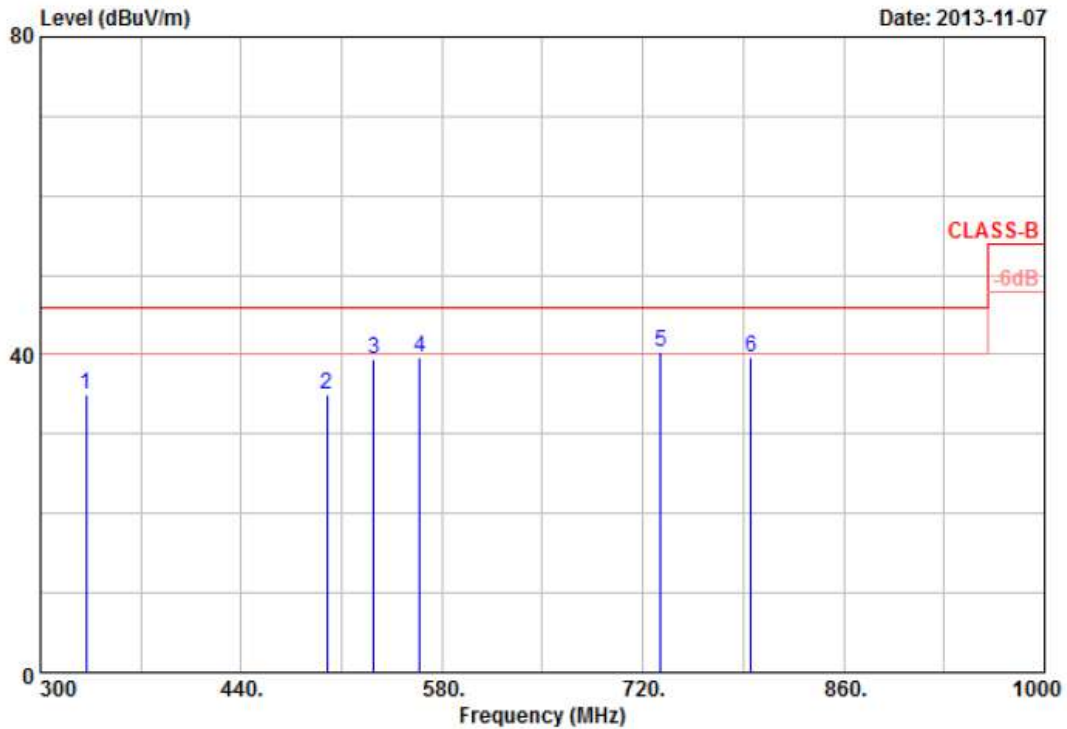

Item	Freq	Read Value	Factor	Result	Limit	Margin	Remark	Ant Pos	Tab Pos
	MHz	dBuV	dB/m	dBuV/m	dBuV/m	dB		cm	Deg
1	331.50	42.53	-7.64	34.89	46.00	-11.11	Peak	100	0
2	499.50	40.21	-5.11	35.10	46.00	-10.90	Peak	100	0
3	532.40	37.26	2.23	39.49	46.00	-6.51	Peak	100	0
4	564.60	32.98	6.59	39.57	46.00	-6.43	Peak	100	0
5	732.60	33.27	7.02	40.29	46.00	-5.71	QP	100	0
6	795.60	33.64	6.06	39.70	46.00	-6.30	Peak	100	0

Notes:

1. Result = Read Value + Factor
2. Factor = Antenna Factor + Cable Loss - Amplifier
3. The resolution bandwidth of test receiver/spectrum analyzer is 120KHz and video bandwidth is 300kHz for Peak detection and Quasi-peak detection at frequency below 1GHz.
4. All below 1GHz configurations are pretested among available 802.11b/g/n modes and found that the worst cases are on channel 1 of 802.11g & n20 mode and Channel 3 for n40 mode. Only worst case data concluded above were presented in this test report.
5. The data is worse case.



Power	: AC 120V	Pol/Phase	: HORIZONTAL
Modulation Type	: 802.11n HT20	Temperature	: 25 °C
Operation Channel	: 1	Humidity	: 59 %
Test Date	: Nov. 07, 2013	Atmospheric Pressure	: 1019 hPa

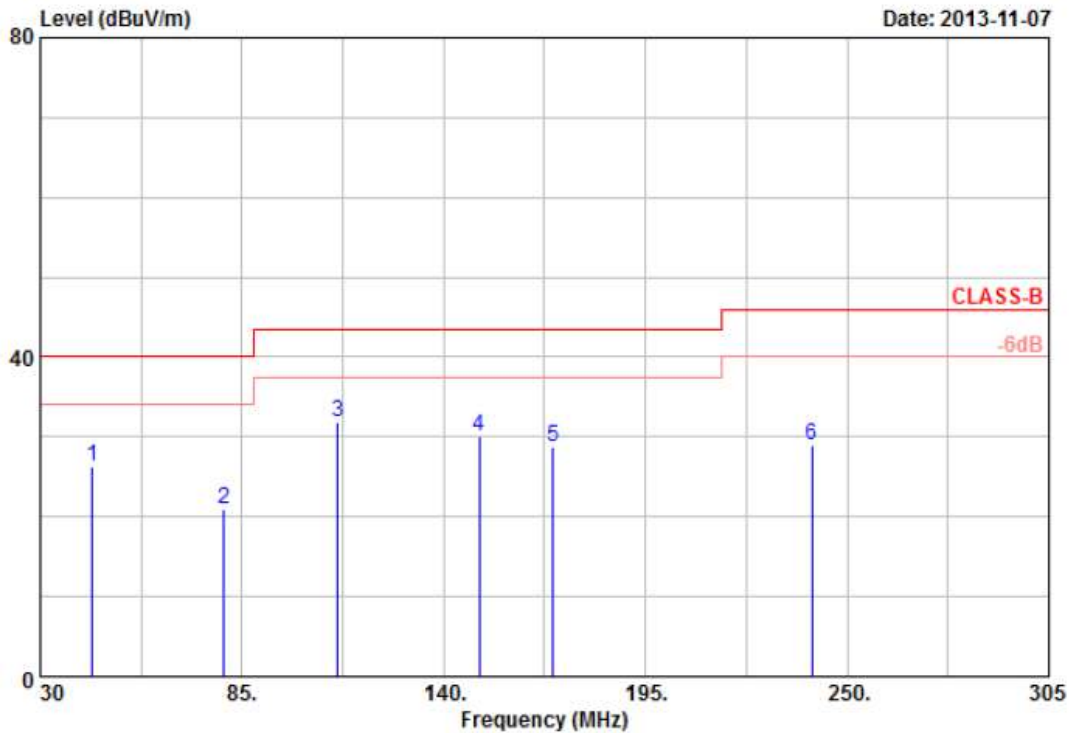

Item	Freq	Read Value	Factor	Result	Limit	Margin	Remark	Ant Pos	Tab Pos
	MHz	dBuV	dB/m	dBuV/m	dBuV/m	dB		cm	Deg
1	44.30	34.49	-8.12	26.37	40.00	-13.63	Peak	100	360
2	80.05	39.67	-18.63	21.04	40.00	-18.96	Peak	100	360
3	111.13	50.72	-18.96	31.76	43.50	-11.74	Peak	100	360
4	149.63	44.76	-14.70	30.06	43.50	-13.44	Peak	100	360
5	169.70	40.11	-11.27	28.84	43.50	-14.66	Peak	100	360
6	240.38	42.85	-13.99	28.86	46.00	-17.14	Peak	100	360

Notes:

1. Result = Read Value + Factor
2. Factor = Antenna Factor + Cable Loss - Amplifier
3. The resolution bandwidth of test receiver/spectrum analyzer is 120KHz and video bandwidth is 300kHz for Peak detection and Quasi-peak detection at frequency below 1GHz.
4. All below 1GHz configurations are pretested among available 802.11b/g/n modes and found that the worst cases are on channel 1 of 802.11g & n20 mode and Channel 3 for n40 mode. Only worst case data concluded above were presented in this test report.
5. The data is worse case.



Power	: AC 120V	Pol/Phase	: HORIZONTAL
Modulation Type	: 802.11n HT20	Temperature	: 25 °C
Operation Channel	: 1	Humidity	: 59 %
Test Date	: Nov. 07, 2013	Atmospheric Pressure	: 1019 hPa

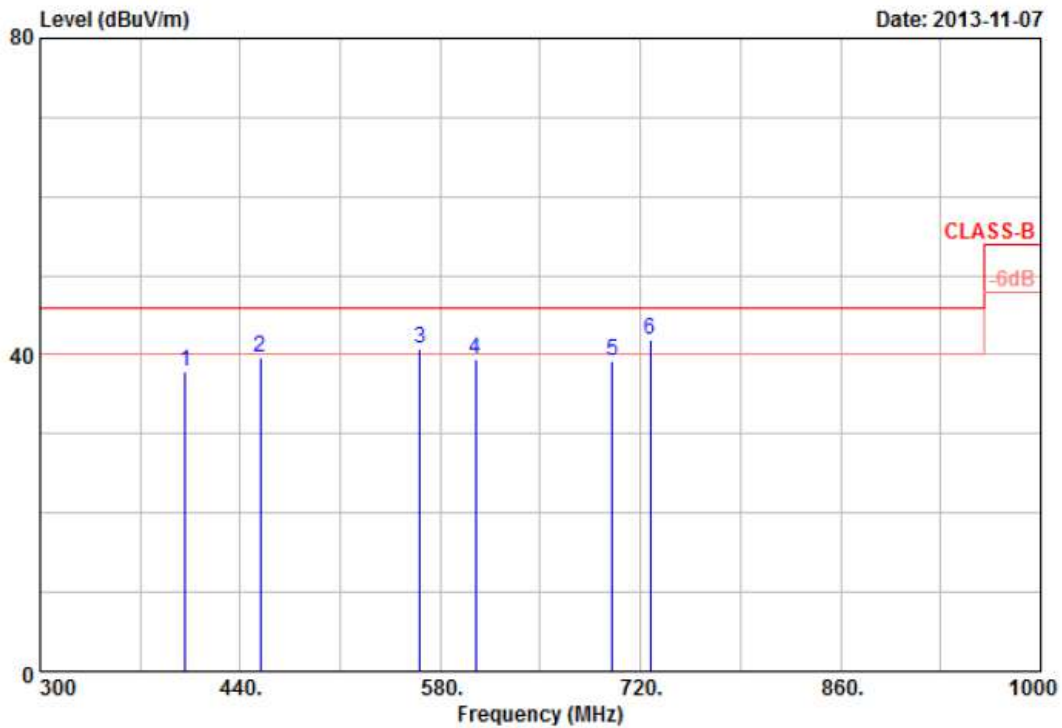

Item	Freq	Read Value	Factor	Result	Limit	Margin	Remark	Ant Pos	Tab Pos
	MHz	dBuV	dB/m	dBuV/m	dBuV/m	dB		cm	Deg
1	401.50	46.88	-9.02	37.86	46.00	-8.14	Peak	100	0
2	454.00	44.39	-4.67	39.72	46.00	-6.28	Peak	100	0
3	566.00	38.36	2.40	40.76	46.00	-5.24	QP	100	0
4	604.50	37.71	1.84	39.55	46.00	-6.45	Peak	100	0
5	700.40	37.03	2.19	39.22	46.00	-6.78	Peak	100	0
6	727.00	38.13	3.77	41.90	46.00	-4.10	QP	100	0

Notes:

1. Result = Read Value + Factor
2. Factor = Antenna Factor + Cable Loss - Amplifier
3. The resolution bandwidth of test receiver/spectrum analyzer is 120kHz and video bandwidth is 300kHz for Peak detection and Quasi-peak detection at frequency below 1GHz.
4. All below 1GHz configurations are pretested among available 802.11b/g/n modes and found that the worst cases are on channel 1 of 802.11g & n20 mode and Channel 3 for n40 mode. Only worst case data concluded above were presented in this test report.
5. The data is worse case.



Power	: AC 120V	Pol/Phase	: VERTICAL
Modulation Type	: 802.11n HT20	Temperature	: 25 °C
Operation Channel	: 1	Humidity	: 56 %
Test Date	: Nov. 08, 2013	Atmospheric Pressure	: 1018 hPa

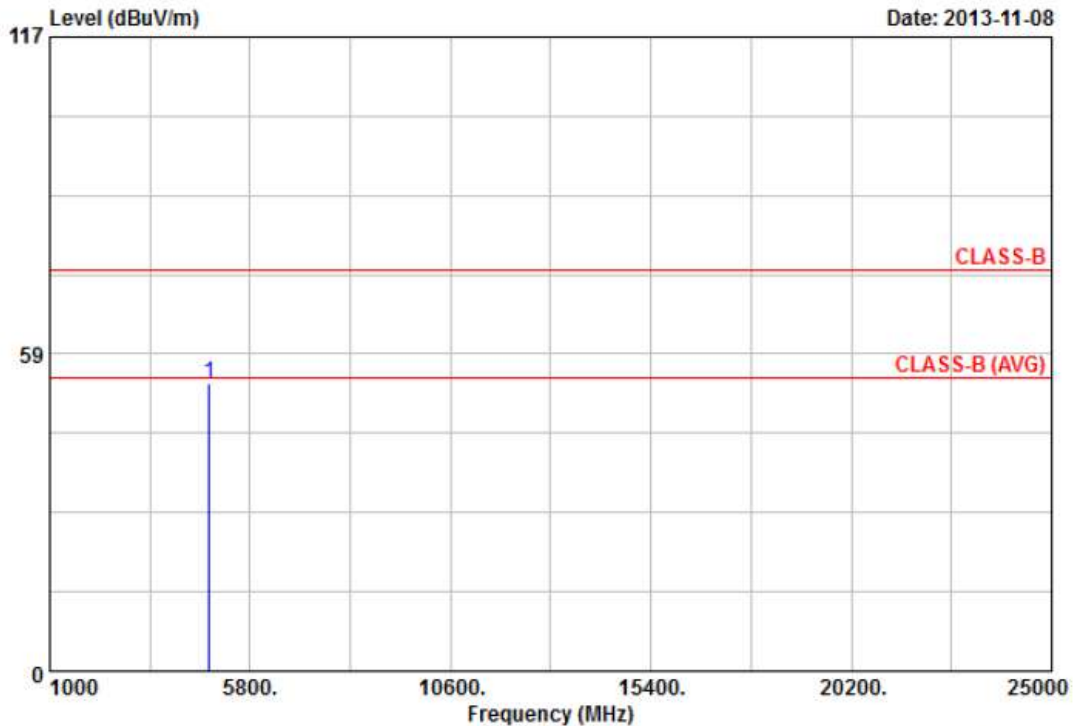

Item	Freq	Read Value	Factor	Result	Limit	Margin	Remark	Ant Pos	Tab Pos
	MHz	dBuV	dB/m	dBuV/m	dBuV/m	dB		cm	Deg
1	4824.10	47.33	5.67	53.00	74.00	-21.00	Peak	100	196

Notes:

1. Result = Read Value + Factor
2. Factor = Antenna Factor + Cable Loss - Amplifier
3. The resolution bandwidth of test receiver/spectrum analyzer is 120KHz and video bandwidth is 300kHz for Peak detection and Quasi-peak detection at frequency below 1GHz.
4. The resolution bandwidth of test receiver/spectrum analyzer is 1MHz and video bandwidth is 3MHz for Peak detection at frequency above 1GHz.
5. The resolution bandwidth of test receiver/spectrum analyzer is 1MHz and video bandwidth is 3MHz (detector sample mode) for Average detection at frequency above 1GHz.
6. The other emissions is too low to be measured. (The worst case noise floor measurements value is 47.93 dBuV at 16.10GHz)
7. The data is worse case.



Power	: AC 120V	Pol/Phase	: HORIZONTAL
Modulation Type	: 802.11n HT20	Temperature	: 25 °C
Operation Channel	: 1	Humidity	: 56 %
Test Date	: Nov. 08, 2013	Atmospheric Pressure	: 1018 hPa

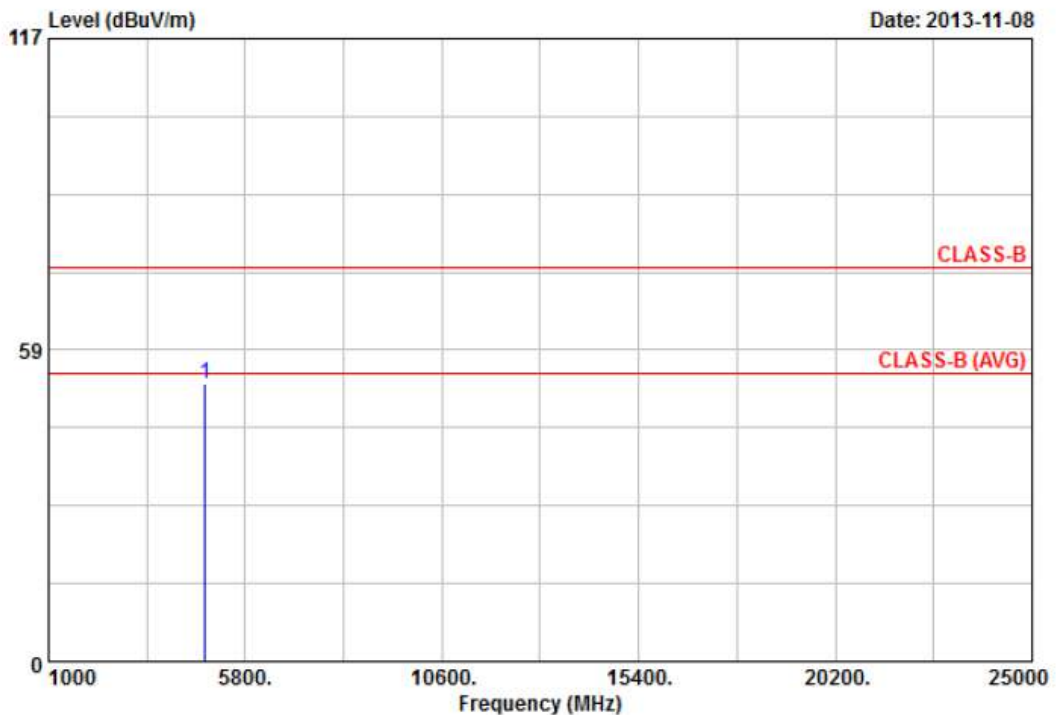

Item	Freq	Read Value	Factor	Result	Limit	Margin	Remark	Ant Pos	Tab Pos
	MHz	dBuV	dB/m	dBuV/m	dBuV/m	dB		cm	Deg
1	4822.80	48.26	3.99	52.25	74.00	-21.75	Peak	100	196

Notes:

1. Result = Read Value + Factor
2. Factor = Antenna Factor + Cable Loss - Amplifier
3. The resolution bandwidth of test receiver/spectrum analyzer is 120KHz and video bandwidth is 300kHz for Peak detection and Quasi-peak detection at frequency below 1GHz.
4. The resolution bandwidth of test receiver/spectrum analyzer is 1MHz and video bandwidth is 3MHz for Peak detection at frequency above 1GHz.
5. The resolution bandwidth of test receiver/spectrum analyzer is 1MHz and video bandwidth is 3MHz (detector sample mode) for Average detection at frequency above 1GHz.
6. The other emissions is too low to be measured. (The worst case noise floor measurements value is 47.93 dBuV at 16.10GHz)
7. The data is worse case.



Power	: AC 120V	Pol/Phase	: VERTICAL
Modulation Type	: 802.11n HT20	Temperature	: 25 °C
Operation Channel	: 6	Humidity	: 56 %
Test Date	: Nov. 08, 2013	Atmospheric Pressure	: 1018 hPa

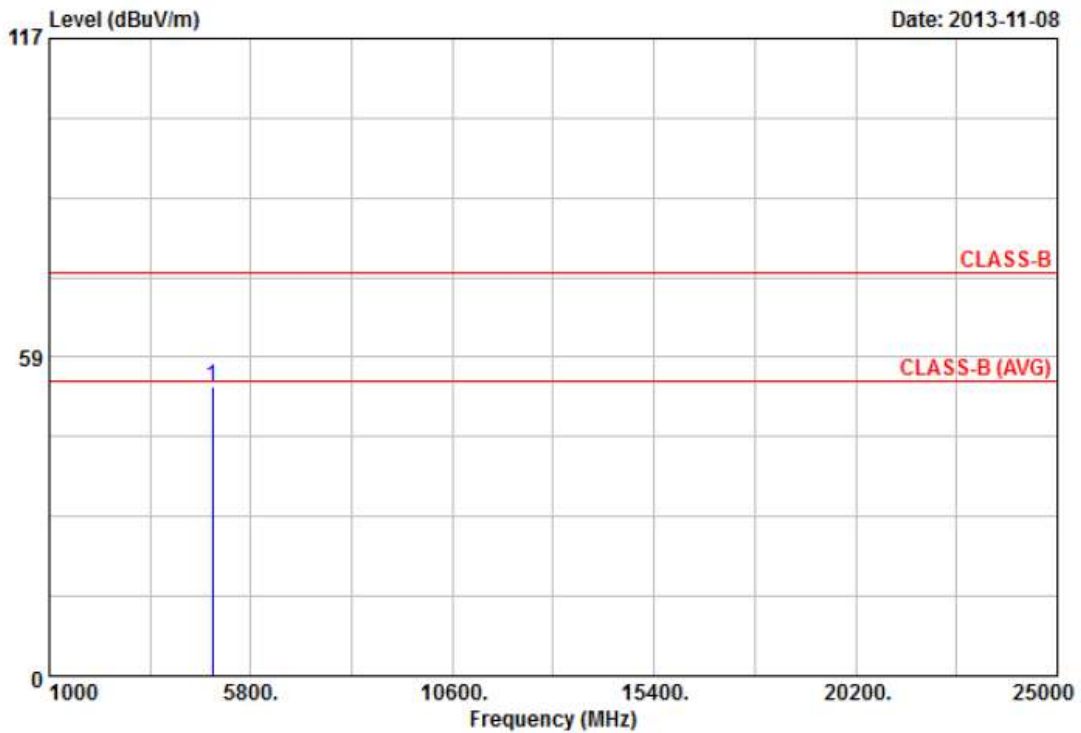

Item	Freq	Read Value	Factor	Result	Limit	Margin	Remark	Ant Pos	Tab Pos
	MHz	dBuV	dB/m	dBuV/m	dBuV/m	dB		cm	Deg
1	4874.70	46.55	6.66	53.21	74.00	-20.79	Peak	100	196

Notes:

1. Result = Read Value + Factor
2. Factor = Antenna Factor + Cable Loss - Amplifier
3. The resolution bandwidth of test receiver/spectrum analyzer is 120KHz and video bandwidth is 300kHz for Peak detection and Quasi-peak detection at frequency below 1GHz.
4. The resolution bandwidth of test receiver/spectrum analyzer is 1MHz and video bandwidth is 3MHz for Peak detection at frequency above 1GHz.
5. The resolution bandwidth of test receiver/spectrum analyzer is 1MHz and video bandwidth is 3MHz (detector sample mode) for Average detection at frequency above 1GHz.
6. The other emissions is too low to be measured. (The worst case noise floor measurements value is 47.93 dBuV at 16.10GHz)
7. The data is worse case.



Power	: AC 120V	Pol/Phase	: HORIZONTAL
Modulation Type	: 802.11n HT20	Temperature	: 25 °C
Operation Channel	: 6	Humidity	: 56 %
Test Date	: Nov. 08, 2013	Atmospheric Pressure	: 1018 hPa

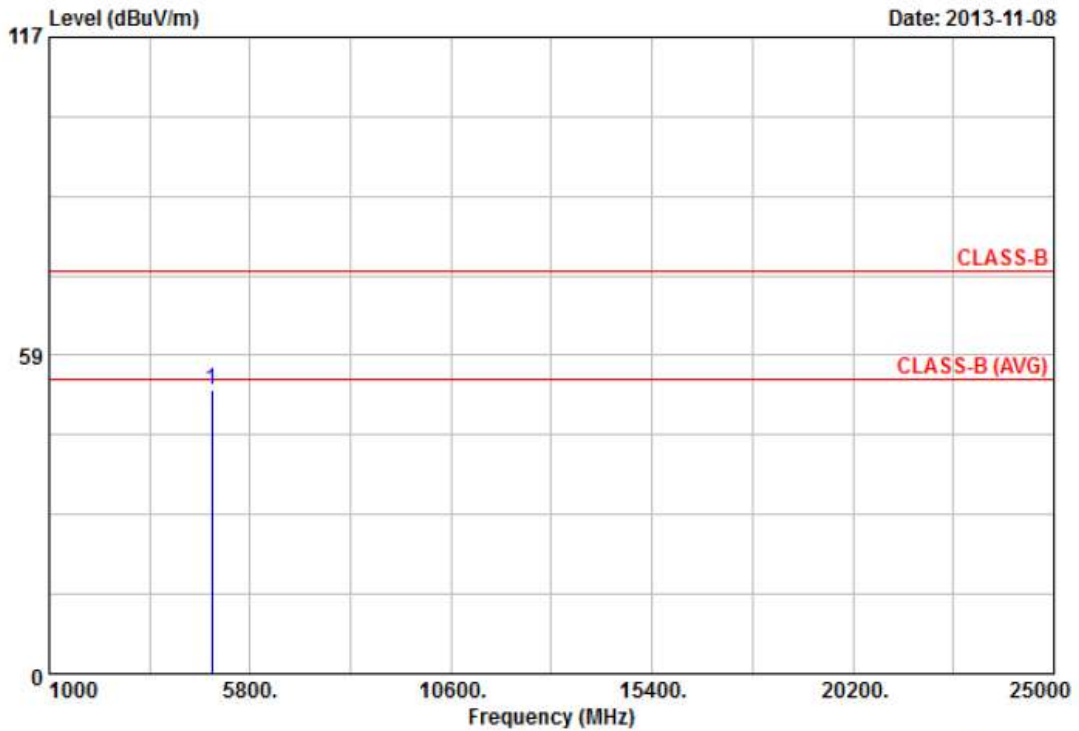

Item	Freq	Read Value	Factor	Result	Limit	Margin	Remark	Ant Pos	Tab Pos
	MHz	dBuV	dB/m	dBuV/m	dBuV/m	dB		cm	Deg
1	4875.45	47.31	4.82	52.13	74.00	-21.87	Peak	100	196

Notes:

1. Result = Read Value + Factor
2. Factor = Antenna Factor + Cable Loss - Amplifier
3. The resolution bandwidth of test receiver/spectrum analyzer is 120KHz and video bandwidth is 300kHz for Peak detection and Quasi-peak detection at frequency below 1GHz.
4. The resolution bandwidth of test receiver/spectrum analyzer is 1MHz and video bandwidth is 3MHz for Peak detection at frequency above 1GHz.
5. The resolution bandwidth of test receiver/spectrum analyzer is 1MHz and video bandwidth is 3MHz (detector sample mode) for Average detection at frequency above 1GHz.
6. The other emissions is too low to be measured. (The worst case noise floor measurements value is 47.93 dBuV at 16.10GHz)
7. The data is worse case.



Power	: AC 120V	Pol/Phase	: VERTICAL
Modulation Type	: 802.11n HT20	Temperature	: 25 °C
Operation Channel	: 11	Humidity	: 56 %
Test Date	: Nov. 08, 2013	Atmospheric Pressure	: 1018 hPa

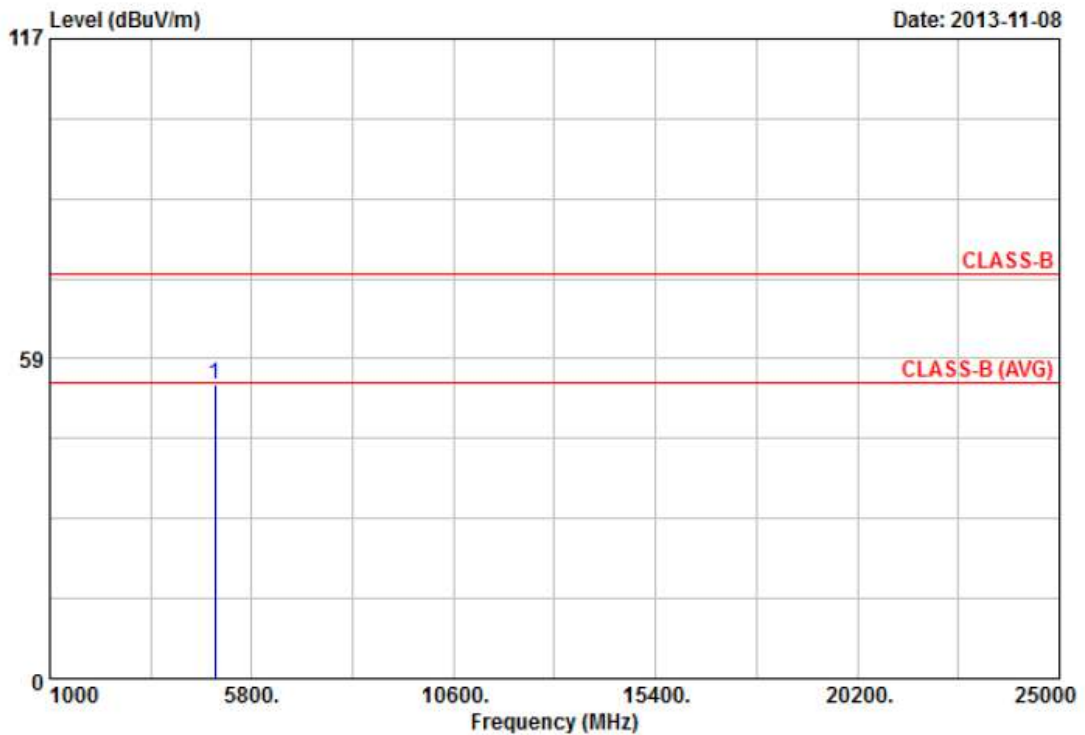

Item	Freq	Read Value	Factor	Result	Limit	Margin	Remark	Ant Pos	Tab Pos
	MHz	dBuV	dB/m	dBuV/m	dBuV/m	dB		cm	Deg
1	4924.80	46.55	7.21	53.76	74.00	-20.24	Peak	100	196

Notes:

1. Result = Read Value + Factor
2. Factor = Antenna Factor + Cable Loss - Amplifier
3. The resolution bandwidth of test receiver/spectrum analyzer is 120KHz and video bandwidth is 300kHz for Peak detection and Quasi-peak detection at frequency below 1GHz.
4. The resolution bandwidth of test receiver/spectrum analyzer is 1MHz and video bandwidth is 3MHz for Peak detection at frequency above 1GHz.
5. The resolution bandwidth of test receiver/spectrum analyzer is 1MHz and video bandwidth is 3MHz (detector sample mode) for Average detection at frequency above 1GHz.
6. The other emissions is too low to be measured. (The worst case noise floor measurements value is 47.93 dBuV at 16.10GHz)
7. The data is worse case.



Power	: AC 120V	Pol/Phase	: HORIZONTAL
Modulation Type	: 802.11n HT20	Temperature	: 25 °C
Operation Channel	: 11	Humidity	: 56 %
Test Date	: Nov. 08, 2013	Atmospheric Pressure	: 1018 hPa

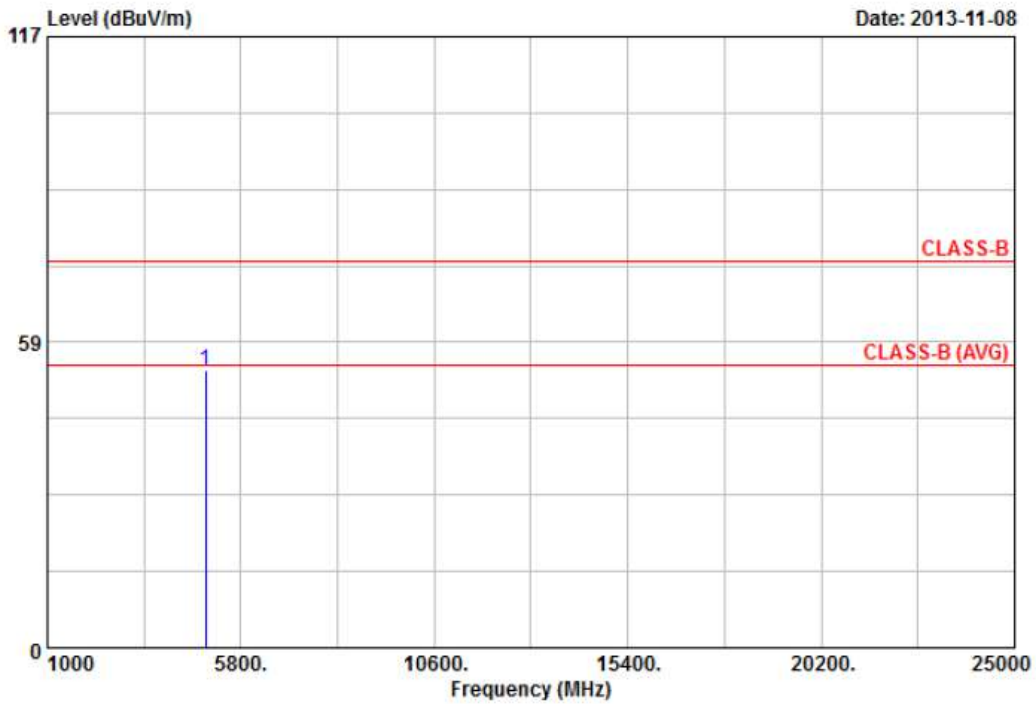

Item	Freq	Read Value	Factor	Result	Limit	Margin	Remark	Ant Pos	Tab Pos
	MHz	dBuV	dB/m	dBuV/m	dBuV/m	dB		cm	Deg
1	4923.38	47.78	5.20	52.98	74.00	-21.02	Peak	100	196

Notes:

1. Result = Read Value + Factor
2. Factor = Antenna Factor + Cable Loss - Amplifier
3. The resolution bandwidth of test receiver/spectrum analyzer is 120KHz and video bandwidth is 300kHz for Peak detection and Quasi-peak detection at frequency below 1GHz.
4. The resolution bandwidth of test receiver/spectrum analyzer is 1MHz and video bandwidth is 3MHz for Peak detection at frequency above 1GHz.
5. The resolution bandwidth of test receiver/spectrum analyzer is 1MHz and video bandwidth is 3MHz (detector sample mode) for Average detection at frequency above 1GHz.
6. The other emissions is too low to be measured. (The worst case noise floor measurements value is 47.93 dBuV at 16.10GHz)
7. The data is worse case.



Power	: AC 120V	Pol/Phase	: VERTICAL
Modulation Type	: 802.11n HT40	Temperature	: 25 °C
Operation Channel	: 3	Humidity	: 59 %
Test Date	: Nov. 07, 2013	Atmospheric Pressure	: 1019 hPa

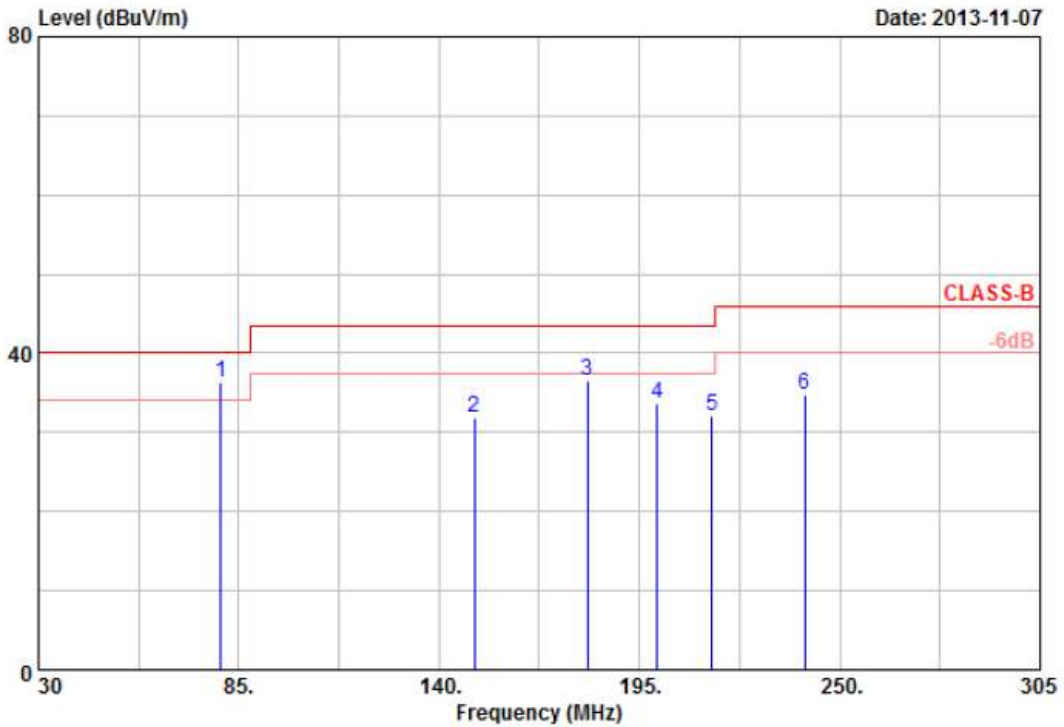

Item	Freq	Read Value	Factor	Result	Limit	Margin	Remark	Ant Pos	Tab Pos
	MHz	dBuV	dB/m	dBuV/m	dBuV/m	dB		cm	Deg
1	80.05	43.68	-7.44	36.24	40.00	-3.76	QP	100	360
2	149.63	42.92	-11.13	31.79	43.50	-11.71	Peak	100	360
3	180.70	42.75	-6.16	36.59	43.50	-6.91	Peak	100	360
4	199.95	45.08	-11.42	33.66	43.50	-9.84	Peak	100	360
5	214.80	39.07	-6.99	32.08	43.50	-11.42	Peak	100	360
6	240.38	44.20	-9.51	34.69	46.00	-11.31	Peak	100	360

Notes:

1. Result = Read Value + Factor
2. Factor = Antenna Factor + Cable Loss - Amplifier
3. The resolution bandwidth of test receiver/spectrum analyzer is 120KHz and video bandwidth is 300kHz for Peak detection and Quasi-peak detection at frequency below 1GHz.
4. All below 1GHz configurations are pretested among available 802.11b/g/n modes and found that the worst cases are on channel 1 of 802.11g & n20 mode and Channel 3 for n40 mode. Only worst case data concluded above were presented in this test report.
5. The data is worse case.



Power	: AC 120V	Pol/Phase	: VERTICAL
Modulation Type	: 802.11n HT40	Temperature	: 25 °C
Operation Channel	: 3	Humidity	: 59 %
Test Date	: Nov. 07, 2013	Atmospheric Pressure	: 1019 hPa

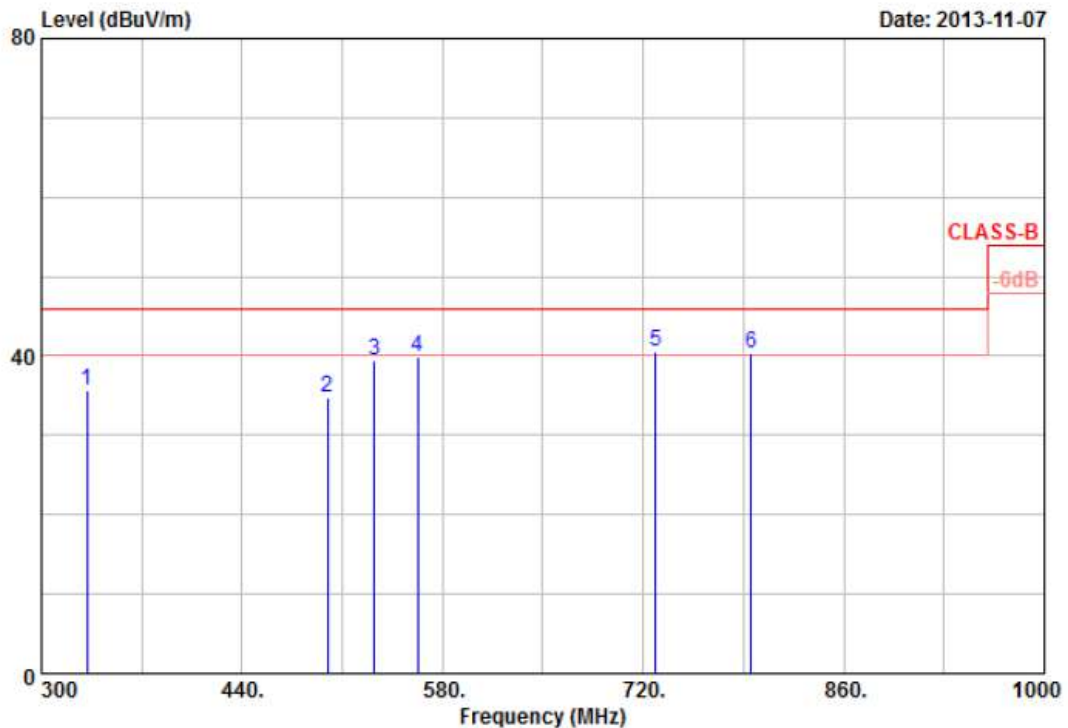

Item	Freq	Read Value	Factor	Result	Limit	Margin	Remark	Ant Pos	Tab Pos
	MHz	dBuV	dB/m	dBuV/m	dBuV/m	dB		cm	Deg
1	331.50	43.38	-7.64	35.74	46.00	-10.26	Peak	100	0
2	499.50	39.98	-5.11	34.87	46.00	-11.13	Peak	100	0
3	532.40	37.12	2.23	39.35	46.00	-6.65	Peak	100	0
4	562.50	33.17	6.82	39.99	46.00	-6.01	Peak	100	0
5	728.40	33.84	6.82	40.66	46.00	-5.34	QP	100	0
6	795.60	34.32	6.06	40.38	46.00	-5.62	QP	100	0

Notes:

1. Result = Read Value + Factor
2. Factor = Antenna Factor + Cable Loss - Amplifier
3. The resolution bandwidth of test receiver/spectrum analyzer is 120KHz and video bandwidth is 300kHz for Peak detection and Quasi-peak detection at frequency below 1GHz.
4. All below 1GHz configurations are pretested among available 802.11b/g/n modes and found that the worst cases are on channel 1 of 802.11g & n20 mode and Channel 3 for n40 mode. Only worst case data concluded above were presented in this test report.
5. The data is worse case.



Power	: AC 120V	Pol/Phase	: HORIZONTAL
Modulation Type	: 802.11n HT40	Temperature	: 25 °C
Operation Channel	: 3	Humidity	: 59 %
Test Date	: Nov. 07, 2013	Atmospheric Pressure	: 1019 hPa

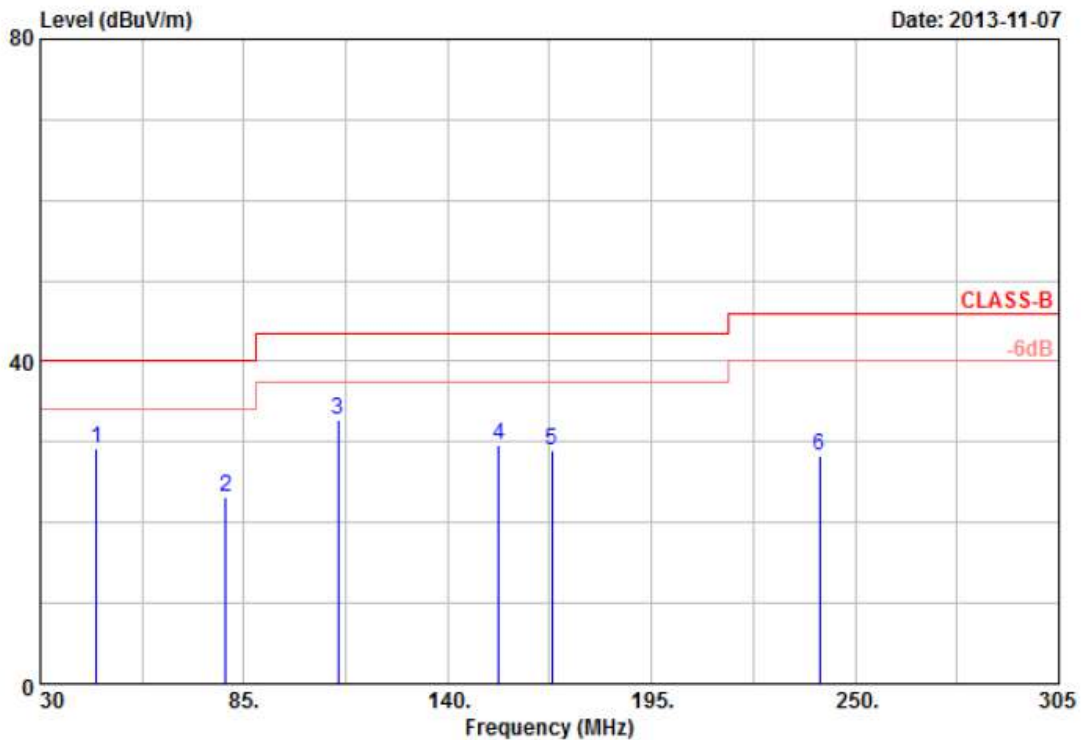

Item	Freq	Read Value	Factor	Result	Limit	Margin	Remark	Ant Pos	Tab Pos
	MHz	dBuV	dB/m	dBuV/m	dBuV/m	dB		cm	Deg
1	45.13	37.43	-8.25	29.18	40.00	-10.82	Peak	100	360
2	80.05	41.77	-18.63	23.14	40.00	-16.86	Peak	100	360
3	110.30	51.78	-18.95	32.83	43.50	-10.67	Peak	100	360
4	153.75	44.93	-15.36	29.57	43.50	-13.93	Peak	100	360
5	168.05	42.01	-13.07	28.94	43.50	-14.56	Peak	100	360
6	240.38	42.25	-13.99	28.26	46.00	-17.74	Peak	100	360

Notes:

1. Result = Read Value + Factor
2. Factor = Antenna Factor + Cable Loss - Amplifier
3. The resolution bandwidth of test receiver/spectrum analyzer is 120KHz and video bandwidth is 300kHz for Peak detection and Quasi-peak detection at frequency below 1GHz.
4. All below 1GHz configurations are pretested among available 802.11b/g/n modes and found that the worst cases are on channel 1 of 802.11g & n20 mode and Channel 3 for n40 mode. Only worst case data concluded above were presented in this test report.
5. The data is worse case.



Power	: AC 120V	Pol/Phase	: HORIZONTAL
Modulation Type	: 802.11n HT40	Temperature	: 25 °C
Operation Channel	: 3	Humidity	: 59 %
Test Date	: Nov. 07, 2013	Atmospheric Pressure	: 1019 hPa

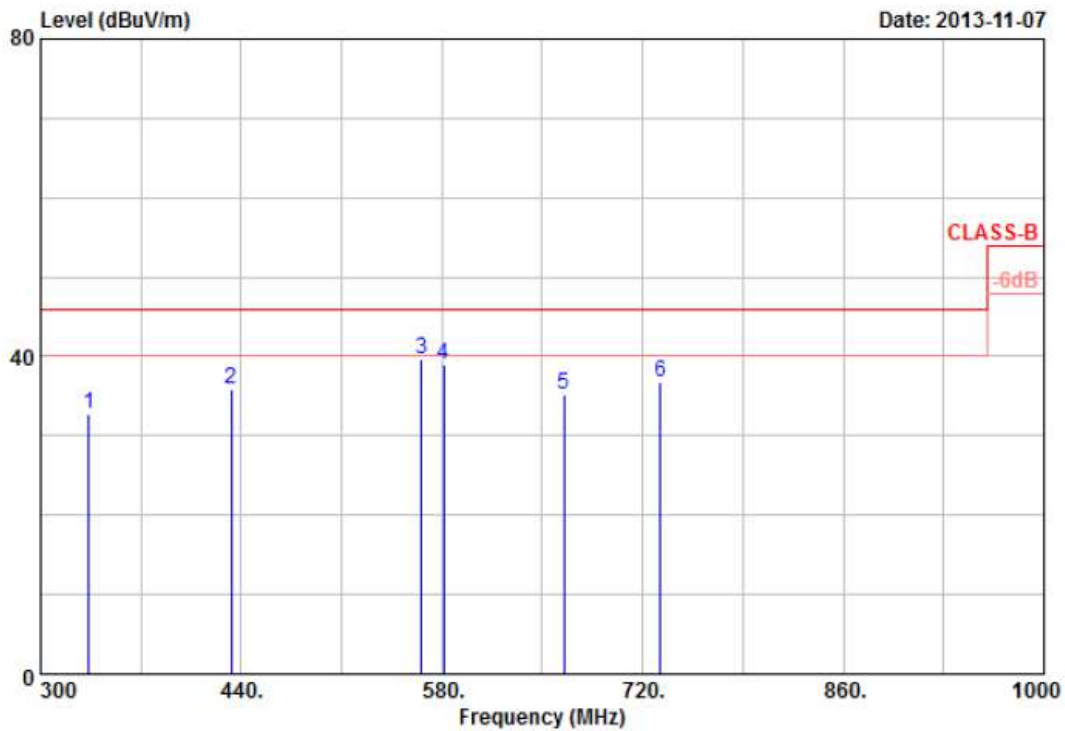

Item	Freq	Read Value	Factor	Result	Limit	Margin	Remark	Ant Pos	Tab Pos
	MHz	dBuV	dB/m	dBuV/m	dBuV/m	dB		cm	Deg
1	333.60	42.60	-9.90	32.70	46.00	-13.30	Peak	100	0
2	433.00	42.80	-6.94	35.86	46.00	-10.14	Peak	100	0
3	566.00	37.25	2.40	39.65	46.00	-6.35	Peak	100	0
4	581.40	36.45	2.47	38.92	46.00	-7.08	Peak	100	0
5	665.40	35.26	-0.12	35.14	46.00	-10.86	Peak	100	0
6	732.60	32.90	3.98	36.88	46.00	-9.12	Peak	100	0

Notes:

1. Result = Read Value + Factor
2. Factor = Antenna Factor + Cable Loss - Amplifier
3. The resolution bandwidth of test receiver/spectrum analyzer is 120KHz and video bandwidth is 300kHz for Peak detection and Quasi-peak detection at frequency below 1GHz.
4. All below 1GHz configurations are pretested among available 802.11b/g/n modes and found that the worst cases are on channel 1 of 802.11g & n20 mode and Channel 3 for n40 mode. Only worst case data concluded above were presented in this test report.
5. The data is worse case.



Power	: AC 120V	Pol/Phase	: VERTICAL
Modulation Type	: 802.11n HT40	Temperature	: 25 °C
Operation Channel	: 3	Humidity	: 56 %
Test Date	: Nov. 08, 2013	Atmospheric Pressure	: 1018 hPa

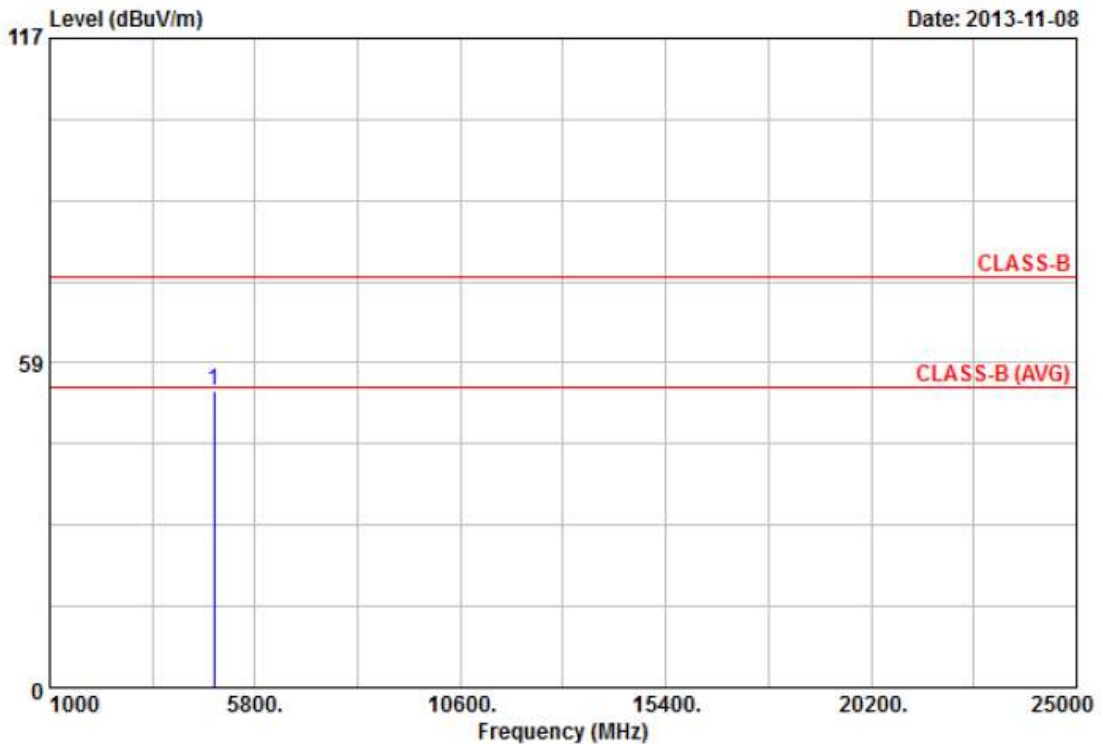

Item	Freq	Read Value	Factor	Result	Limit	Margin	Remark	Ant Pos	Tab Pos
	MHz	dBuV	dB/m	dBuV/m	dBuV/m	dB		cm	Deg
1	4844.25	47.52	6.07	53.59	74.00	-20.41	Peak	100	196

Notes:

1. Result = Read Value + Factor
2. Factor = Antenna Factor + Cable Loss - Amplifier
3. The resolution bandwidth of test receiver/spectrum analyzer is 120KHz and video bandwidth is 300kHz for Peak detection and Quasi-peak detection at frequency below 1GHz.
4. The resolution bandwidth of test receiver/spectrum analyzer is 1MHz and video bandwidth is 3MHz for Peak detection at frequency above 1GHz.
5. The resolution bandwidth of test receiver/spectrum analyzer is 1MHz and video bandwidth is 3MHz (detector sample mode) for Average detection at frequency above 1GHz.
6. The other emissions is too low to be measured. (The worst case noise floor measurements value is 47.93 dBuV at 16.10GHz)
7. The data is worse case.



Power	: AC 120V	Pol/Phase	: HORIZONTAL
Modulation Type	: 802.11n HT40	Temperature	: 25 °C
Operation Channel	: 3	Humidity	: 56 %
Test Date	: Nov. 08, 2013	Atmospheric Pressure	: 1018 hPa

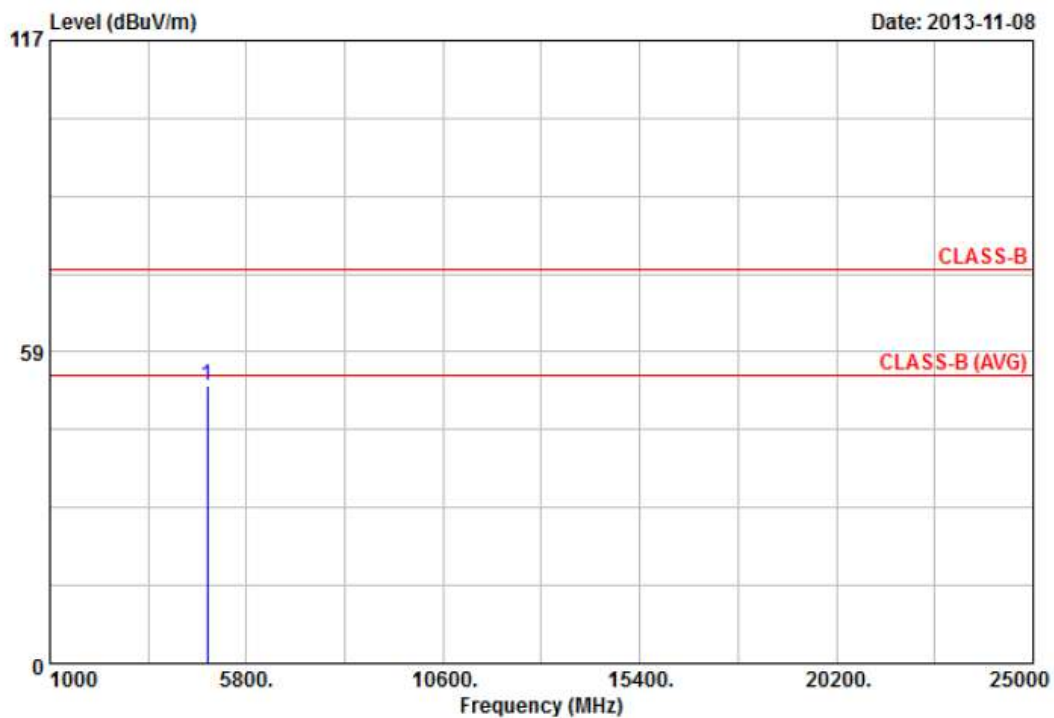

Item	Freq	Read Value	Factor	Result	Limit	Margin	Remark	Ant Pos	Tab Pos
	MHz	dBuV	dB/m	dBuV/m	dBuV/m	dB		cm	Deg
1	4848.83	47.74	4.40	52.14	74.00	-21.86	Peak	100	196

Notes:

1. Result = Read Value + Factor
2. Factor = Antenna Factor + Cable Loss - Amplifier
3. The resolution bandwidth of test receiver/spectrum analyzer is 120KHz and video bandwidth is 300kHz for Peak detection and Quasi-peak detection at frequency below 1GHz.
4. The resolution bandwidth of test receiver/spectrum analyzer is 1MHz and video bandwidth is 3MHz for Peak detection at frequency above 1GHz.
5. The resolution bandwidth of test receiver/spectrum analyzer is 1MHz and video bandwidth is 3MHz (detector sample mode) for Average detection at frequency above 1GHz.
6. The other emissions is too low to be measured. (The worst case noise floor measurements value is 47.93 dBuV at 16.10GHz)
7. The data is worse case.



Power	: AC 120V	Pol/Phase	: VERTICAL
Modulation Type	: 802.11n HT40	Temperature	: 25 °C
Operation Channel	: 6	Humidity	: 56 %
Test Date	: Nov. 08, 2013	Atmospheric Pressure	: 1018 hPa

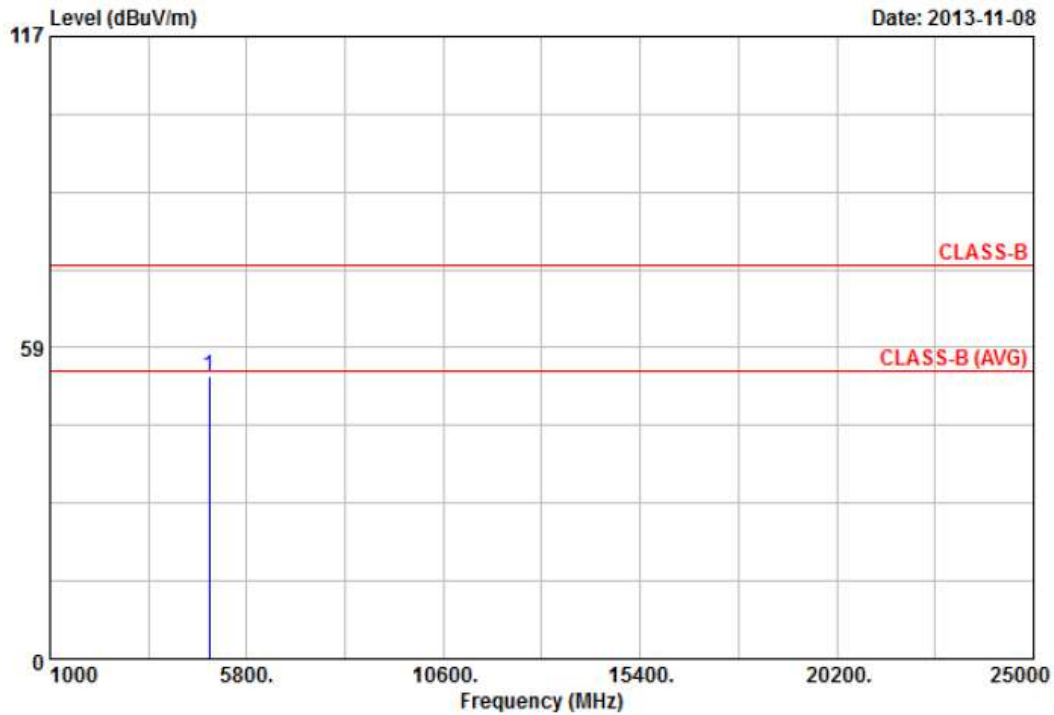

Item	Freq	Read Value	Factor	Result	Limit	Margin	Remark	Ant Pos	Tab Pos
	MHz	dBuV	dB/m	dBuV/m	dBuV/m	dB		cm	Deg
1	4874.03	46.54	6.65	53.19	74.00	-20.81	Peak	100	196

Notes:

1. Result = Read Value + Factor
2. Factor = Antenna Factor + Cable Loss - Amplifier
3. The resolution bandwidth of test receiver/spectrum analyzer is 120KHz and video bandwidth is 300kHz for Peak detection and Quasi-peak detection at frequency below 1GHz.
4. The resolution bandwidth of test receiver/spectrum analyzer is 1MHz and video bandwidth is 3MHz for Peak detection at frequency above 1GHz.
5. The resolution bandwidth of test receiver/spectrum analyzer is 1MHz and video bandwidth is 3MHz (detector sample mode) for Average detection at frequency above 1GHz.
6. The other emissions is too low to be measured. (The worst case noise floor measurements value is 47.93 dBuV at 16.10GHz)
7. The data is worse case.



Power	: AC 120V	Pol/Phase	: HORIZONTAL
Modulation Type	: 802.11n HT40	Temperature	: 25 °C
Operation Channel	: 6	Humidity	: 56 %
Test Date	: Nov. 08, 2013	Atmospheric Pressure	: 1018 hPa

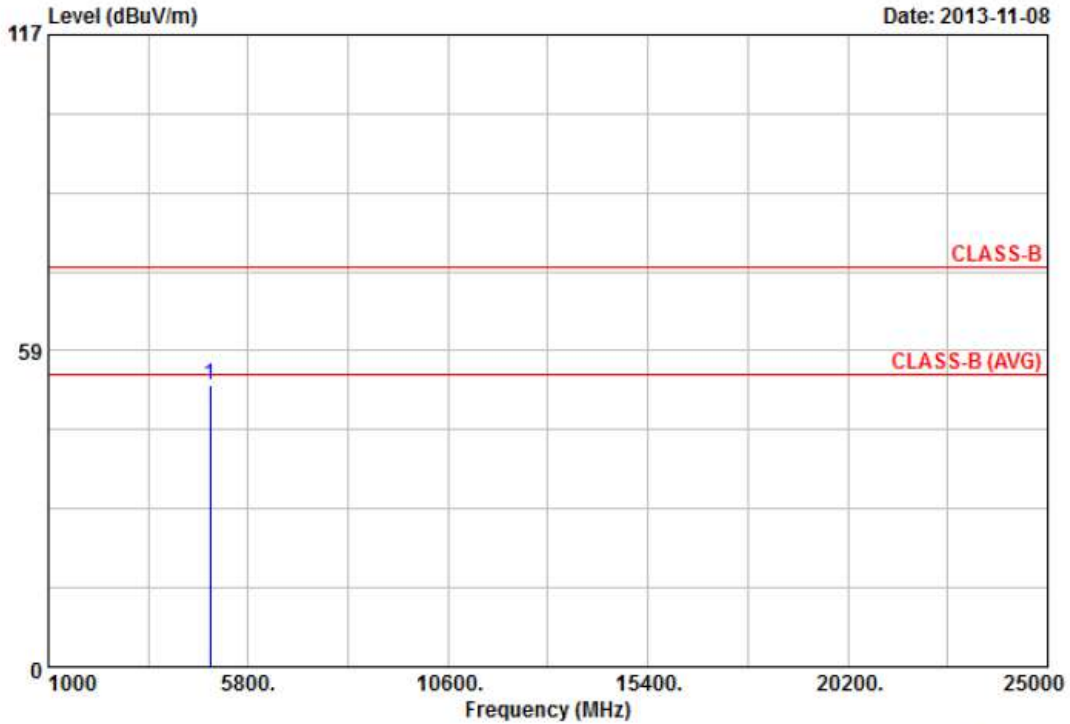

Item	Freq	Read Value	Factor	Result	Limit	Margin	Remark	Ant Pos	Tab Pos
	MHz	dBuV	dB/m	dBuV/m	dBuV/m	dB		cm	Deg
1	4874.10	47.24	4.79	52.03	74.00	-21.97	Peak	100	196

Notes:

1. Result = Read Value + Factor
2. Factor = Antenna Factor + Cable Loss - Amplifier
3. The resolution bandwidth of test receiver/spectrum analyzer is 120KHz and video bandwidth is 300kHz for Peak detection and Quasi-peak detection at frequency below 1GHz.
4. The resolution bandwidth of test receiver/spectrum analyzer is 1MHz and video bandwidth is 3MHz for Peak detection at frequency above 1GHz.
5. The resolution bandwidth of test receiver/spectrum analyzer is 1MHz and video bandwidth is 3MHz (detector sample mode) for Average detection at frequency above 1GHz.
6. The other emissions is too low to be measured. (The worst case noise floor measurements value is 47.93 dBuV at 16.10GHz)
7. The data is worse case.



Power	: AC 120V	Pol/Phase	: VERTICAL
Modulation Type	: 802.11n HT40	Temperature	: 25 °C
Operation Channel	: 9	Humidity	: 56 %
Test Date	: Nov. 08, 2013	Atmospheric Pressure	: 1018 hPa

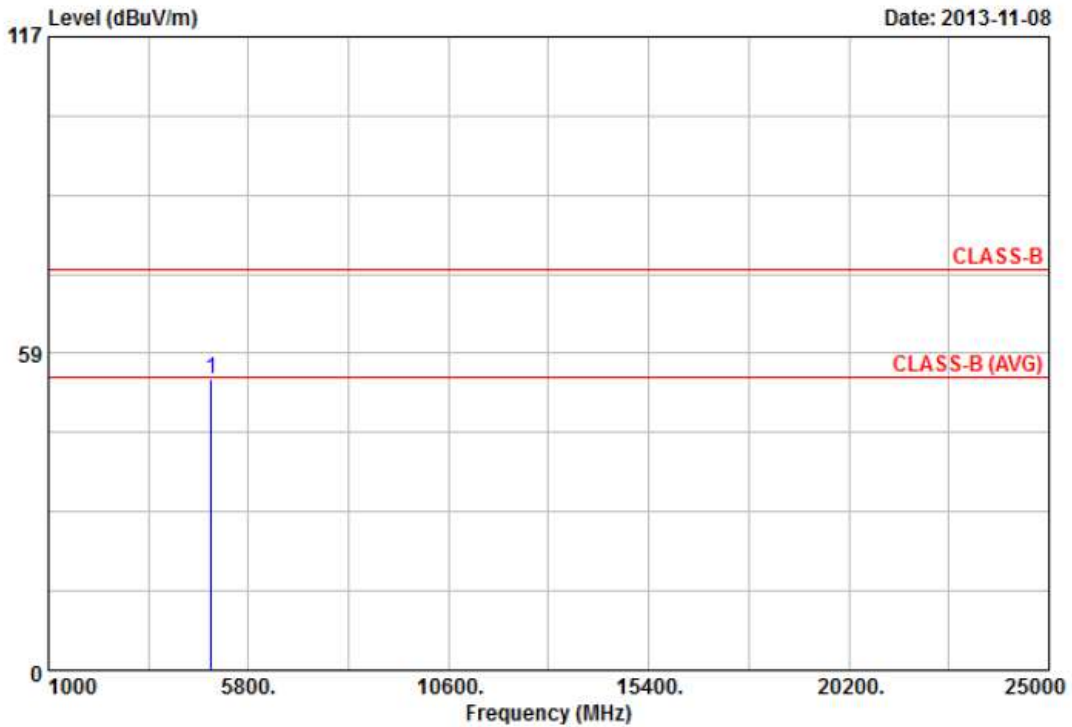

Item	Freq	Read Value	Factor	Result	Limit	Margin	Remark	Ant Pos	Tab Pos
	MHz	dBuV	dB/m	dBuV/m	dBuV/m	dB		cm	Deg
1	4904.80	46.59	7.18	53.77	74.00	-20.23	Peak	100	196

Notes:

1. Result = Read Value + Factor
2. Factor = Antenna Factor + Cable Loss - Amplifier
3. The resolution bandwidth of test receiver/spectrum analyzer is 120KHz and video bandwidth is 300kHz for Peak detection and Quasi-peak detection at frequency below 1GHz.
4. The resolution bandwidth of test receiver/spectrum analyzer is 1MHz and video bandwidth is 3MHz for Peak detection at frequency above 1GHz.
5. The resolution bandwidth of test receiver/spectrum analyzer is 1MHz and video bandwidth is 3MHz (detector sample mode) for Average detection at frequency above 1GHz.
6. The other emissions is too low to be measured. (The worst case noise floor measurements value is 47.93 dBuV at 16.10GHz)
7. The data is worse case.



Power	: AC 120V	Pol/Phase	: HORIZONTAL
Modulation Type	: 802.11n HT40	Temperature	: 25 °C
Operation Channel	: 9	Humidity	: 56 %
Test Date	: Nov. 08, 2013	Atmospheric Pressure	: 1018 hPa

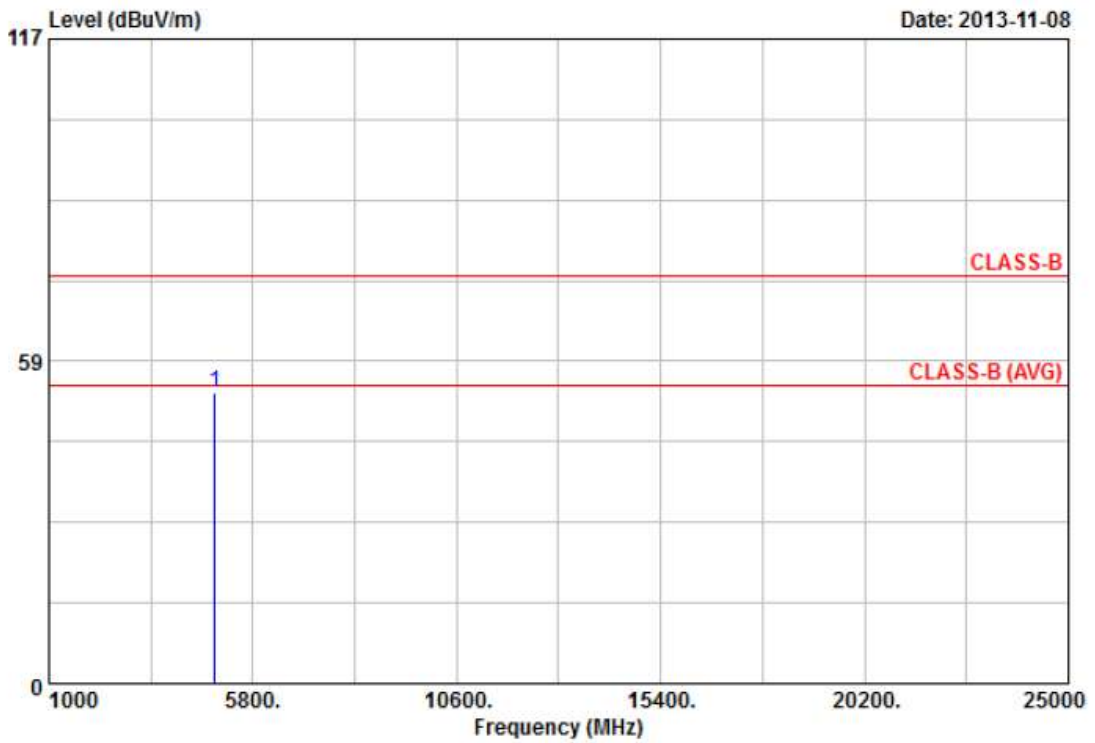

Item	Freq	Read Value	Factor	Result	Limit	Margin	Remark	Ant Pos	Tab Pos
	MHz	dBuV	dB/m	dBuV/m	dBuV/m	dB		cm	Deg
1	4905.18	47.75	5.20	52.95	74.00	-21.05	Peak	100	196

Notes:

1. Result = Read Value + Factor
2. Factor = Antenna Factor + Cable Loss - Amplifier
3. The resolution bandwidth of test receiver/spectrum analyzer is 120KHz and video bandwidth is 300kHz for Peak detection and Quasi-peak detection at frequency below 1GHz.
4. The resolution bandwidth of test receiver/spectrum analyzer is 1MHz and video bandwidth is 3MHz for Peak detection at frequency above 1GHz.
5. The resolution bandwidth of test receiver/spectrum analyzer is 1MHz and video bandwidth is 3MHz (detector sample mode) for Average detection at frequency above 1GHz.
6. The other emissions is too low to be measured. (The worst case noise floor measurements value is 47.93 dBuV at 16.10GHz)
7. The data is worse case.



5.7 Test Photographs (30MHz~1GHz)

Front View

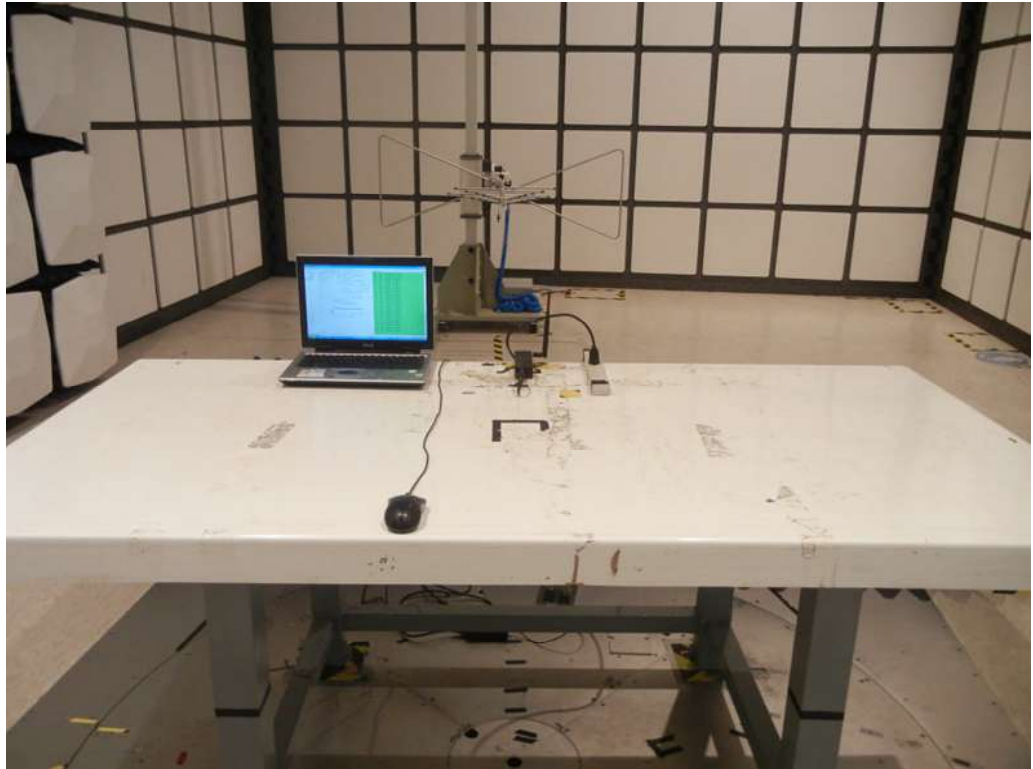

Rear View

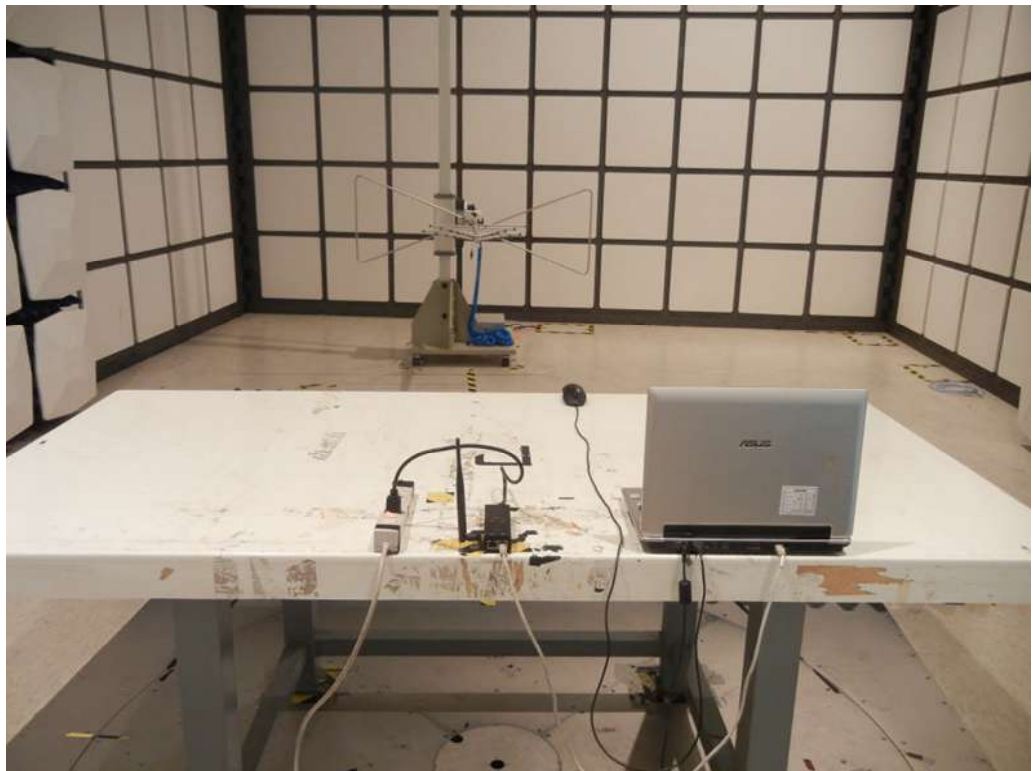



5.8 Test Photographs (1GHz~25GHz)

Front View

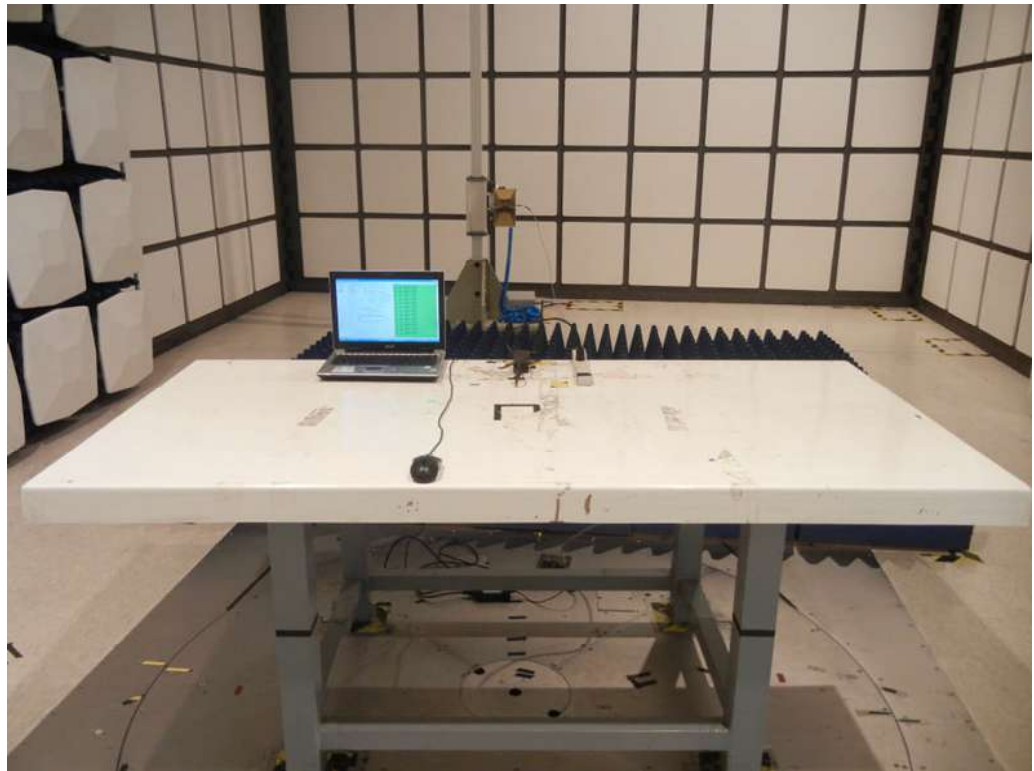

Rear View

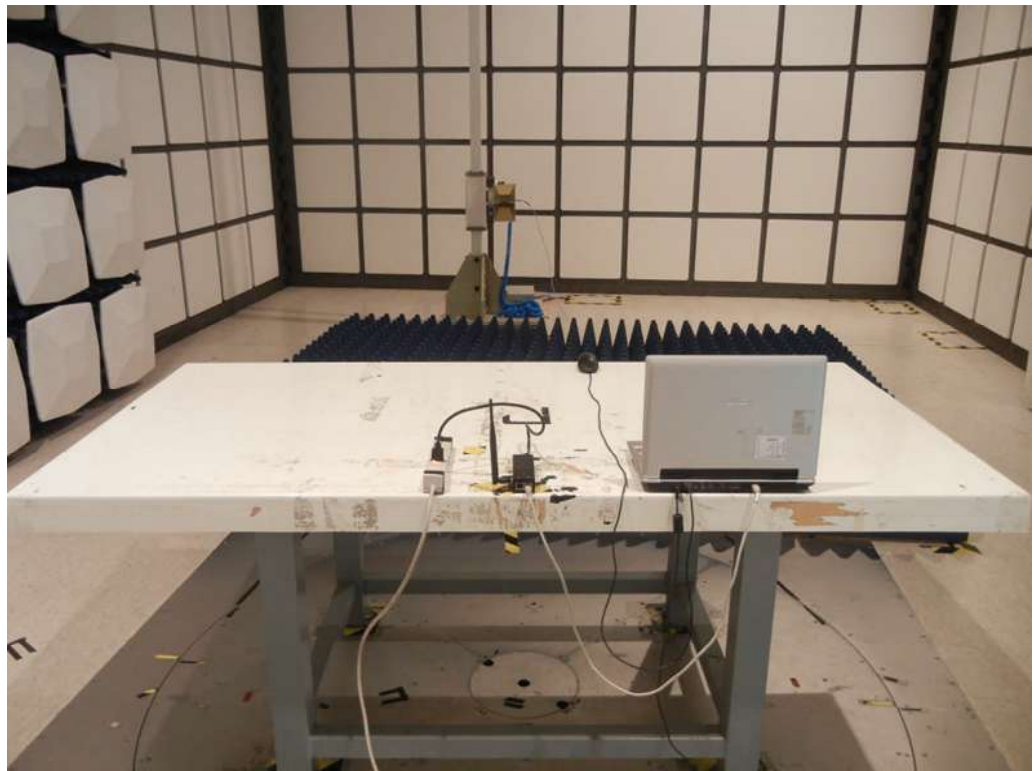



6. 6dB Bandwidth Measurement Data

6.1 Test Limit

The minimum of 6dB Bandwidth Measurement is 0.5 MHz.

6.2 Test Procedures

- The transmitter output was connected to the spectrum analyzer.
- Set RBW of spectrum analyzer to 1~5% or DTS BW and VBW \geq 3x RBW.
- The 6 dB bandwidth is defined as the total spectrum the power of which is higher than peak power minus 6 dB.
- The 6dB Bandwidth was measured and recorded.

6.3 Test Setup Layout

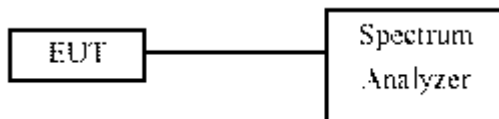

6.4 Measurement Equipment

Instrument/Ancillary	Manufacturer	Model No.	Serial No.	Calibration Date	Valid Date
Spectrum Analyzer	R&S	FSP40	100047	2013/03/15	2014/03/14

6.5 Test Result and Data

Test Date: Nov. 05, 2013

Temperature: 24°C

Atmospheric pressure: 1018 hPa

Humidity: 61%

Modulation Standard	Channel	Frequency (MHz)	6dB Bandwidth (MHz)
802.11b (11Mbps)	01	2412	9.5
	06	2437	9.4
	11	2462	10.1
802.11g (6Mbps)	01	2412	16.4
	06	2437	16.3
	11	2462	16.4
802.11n HT20 (6.5Mbps)	01	2412	17.7
	06	2437	17.6
	11	2462	17.6
802.11n HT40 (13.5Mbps)	03	2422	36.4
	06	2437	36.4
	09	2452	34.6



Modulation Standard: 802.11b (11Mbps)
Channel: 01

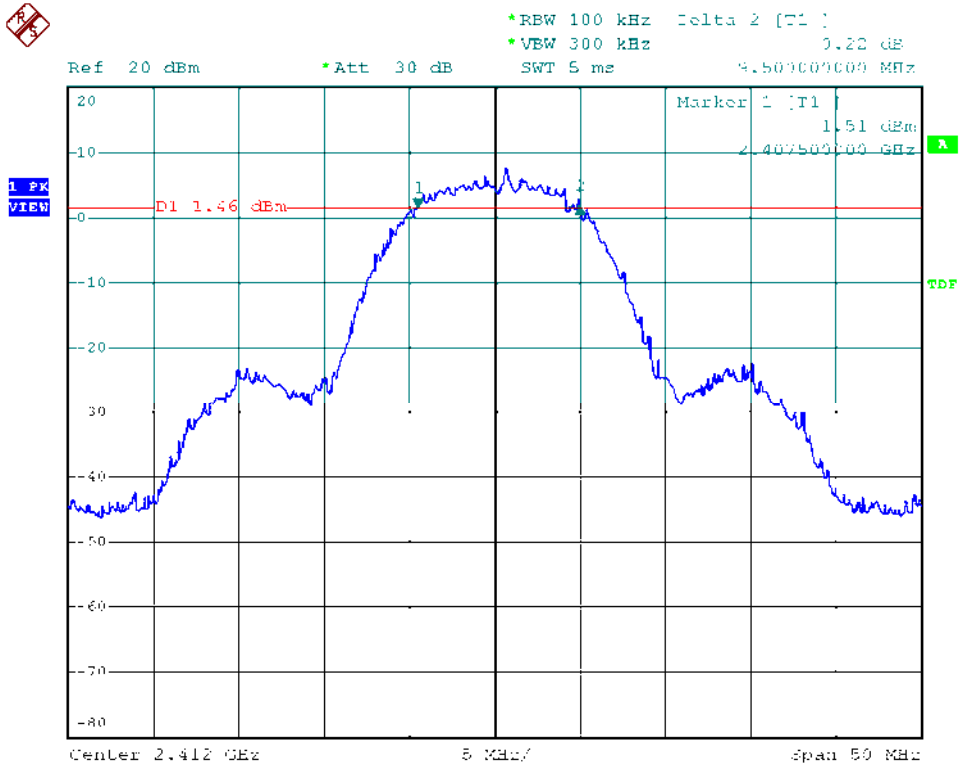

Modulation Standard: 802.11b (11Mbps)
Channel: 06

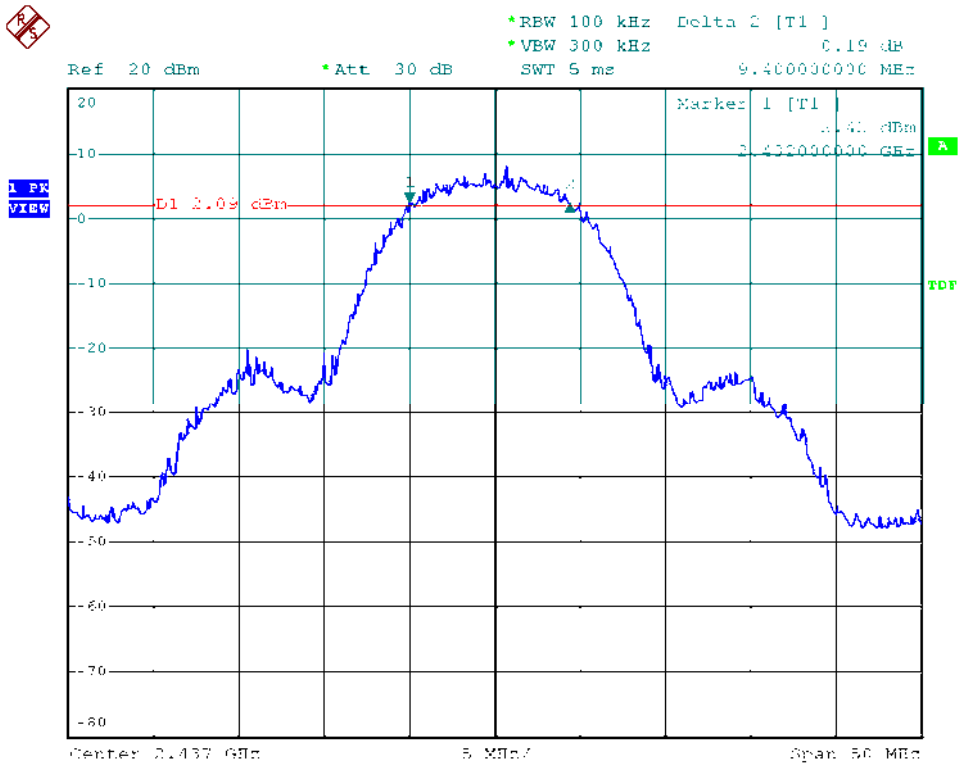



Modulation Standard: 802.11b (11Mbps)
Channel: 11

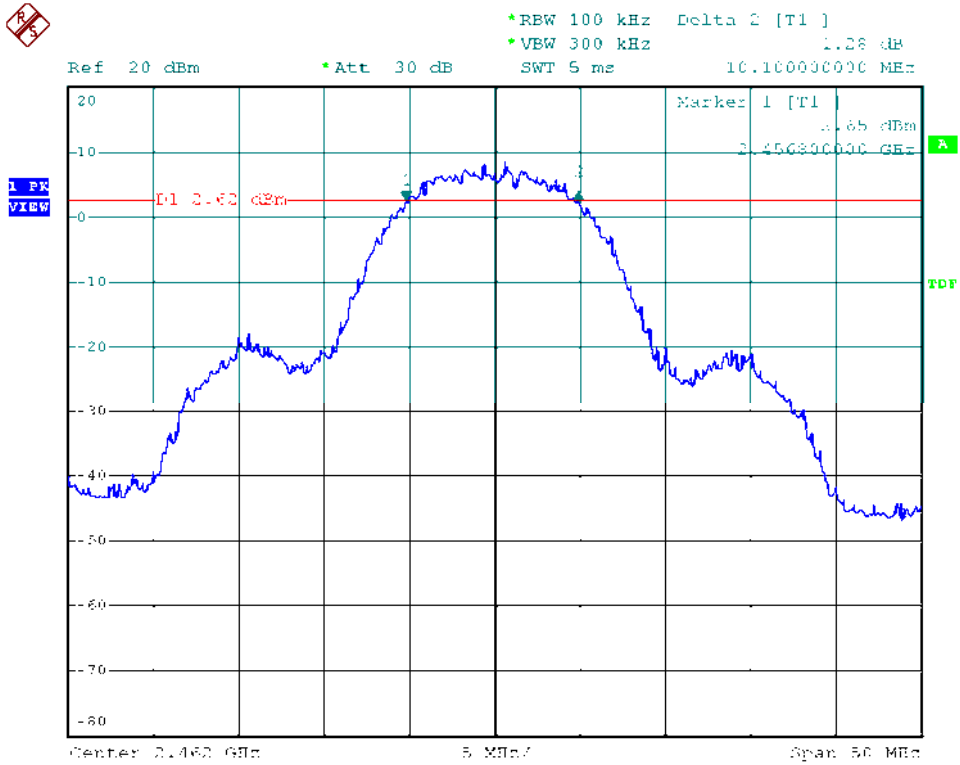

Modulation Standard: 802.11g (6Mbps)
Channel: 01

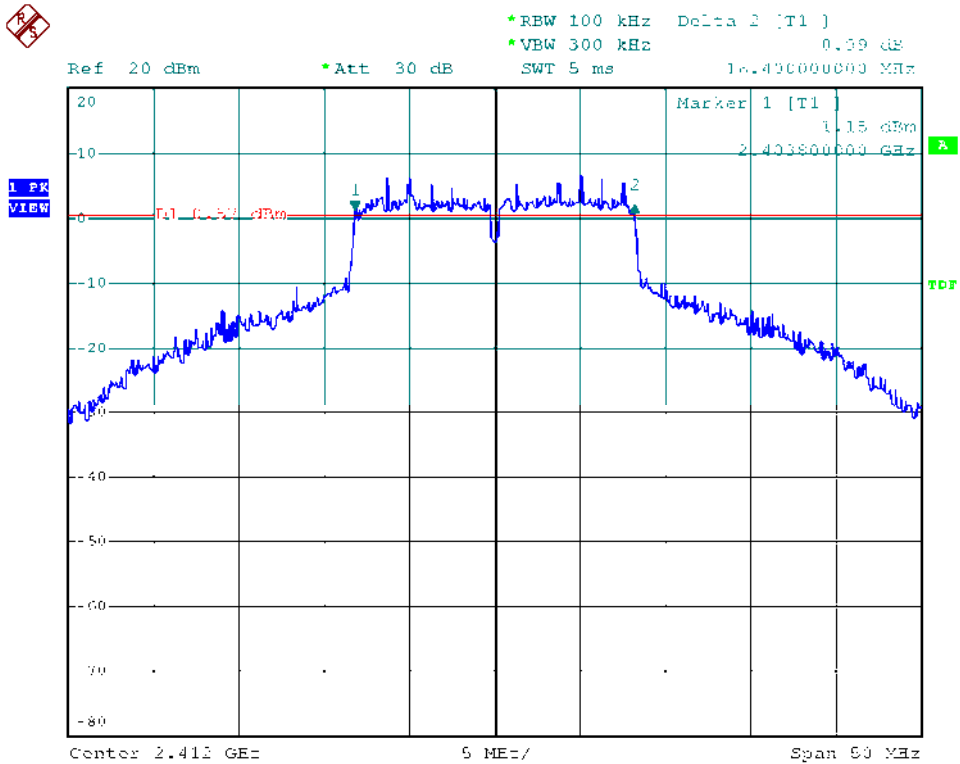



Modulation Standard: 802.11g (6Mbps)
Channel: 06

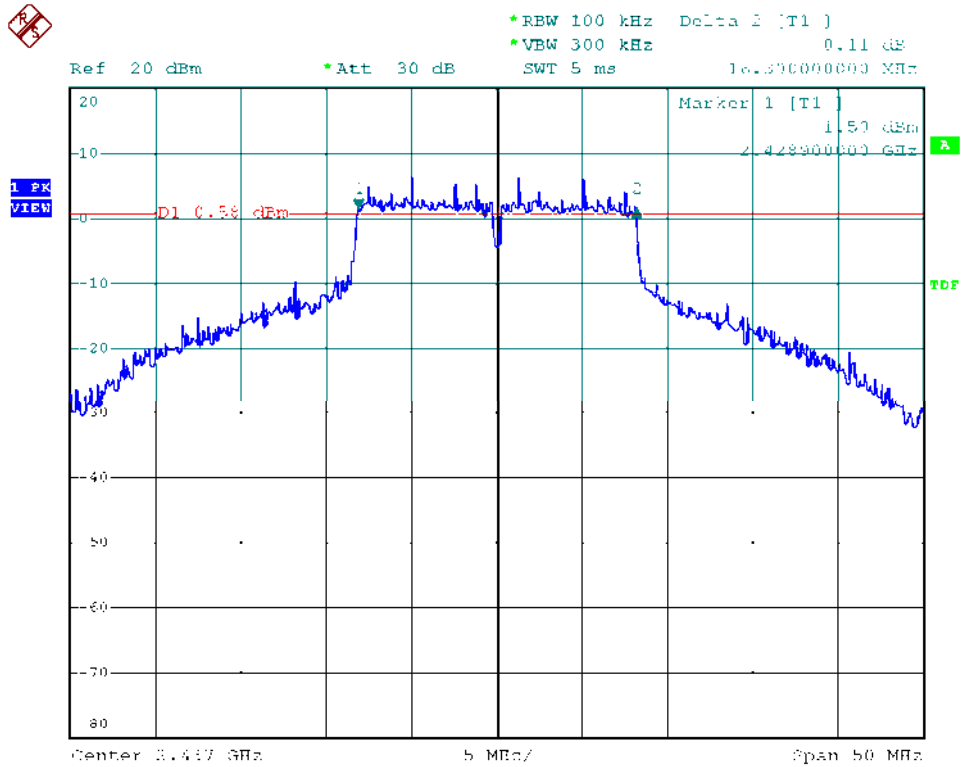

Modulation Standard: 802.11g (6Mbps)
Channel: 11

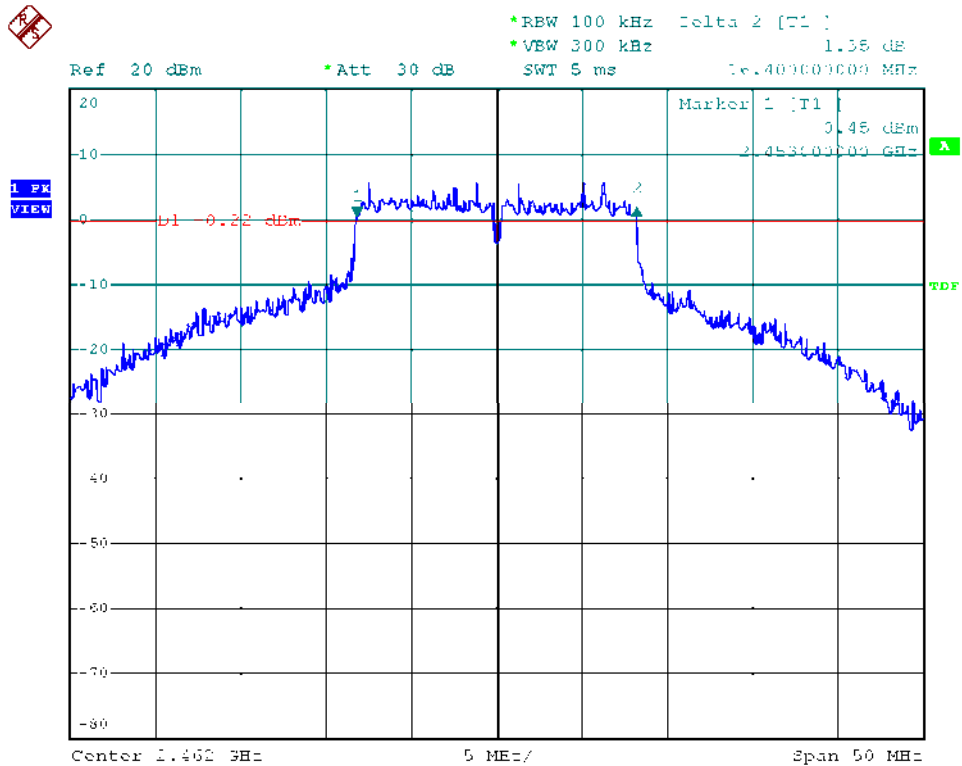



Modulation Standard: 802.11n HT20 (6.5Mbps)
Channel: 01

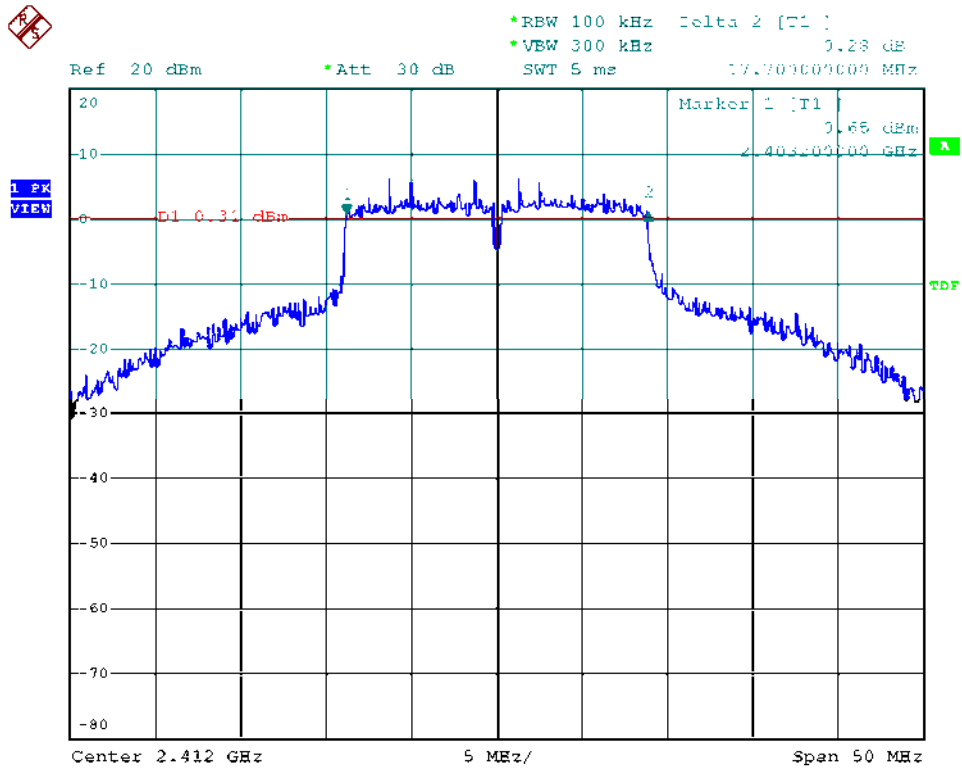

Modulation Standard: 802.11n HT20 (6.5Mbps)
Channel: 06

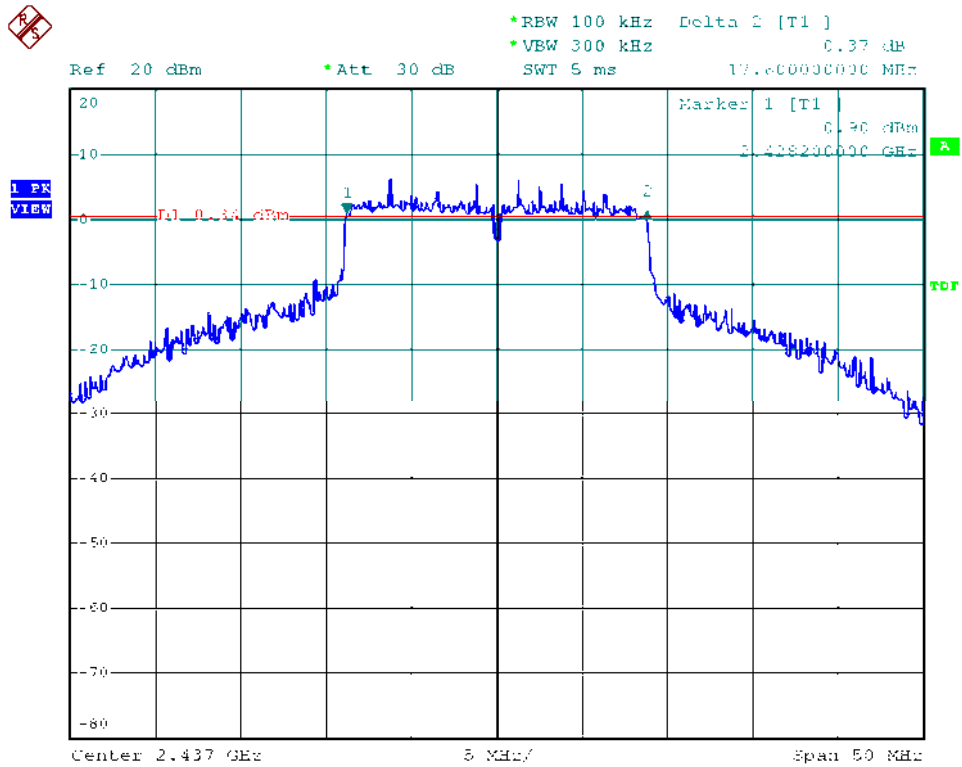



Modulation Standard: 802.11n HT20 (6.5Mbps)
Channel: 11

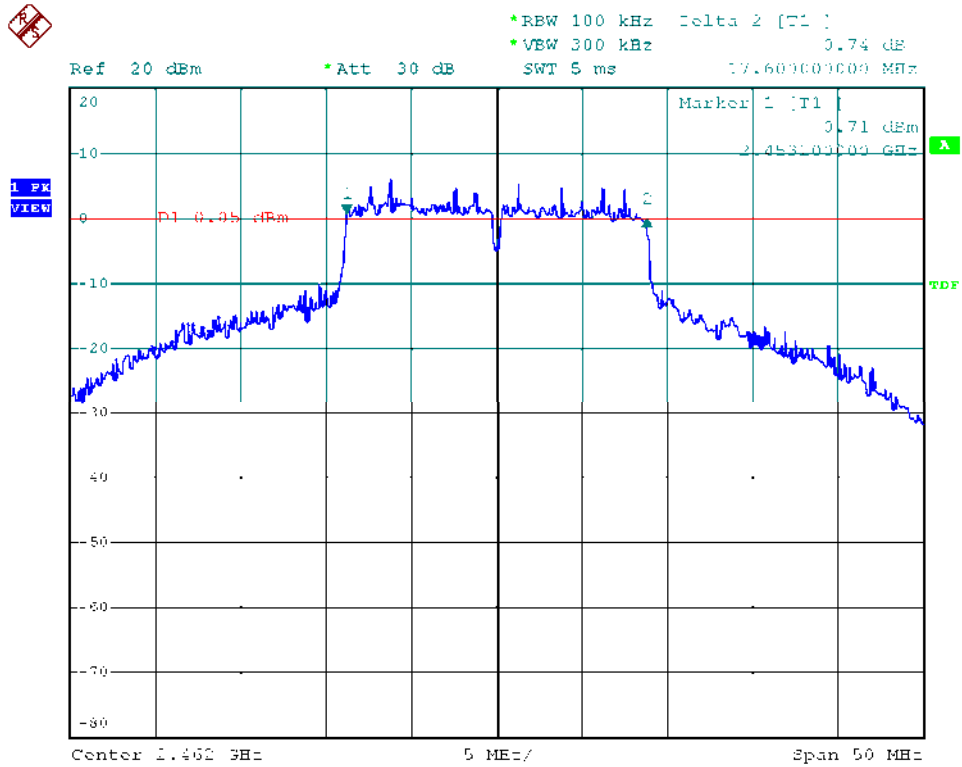

Modulation Standard: 802.11n HT40 (13.5Mbps)
Channel: 03

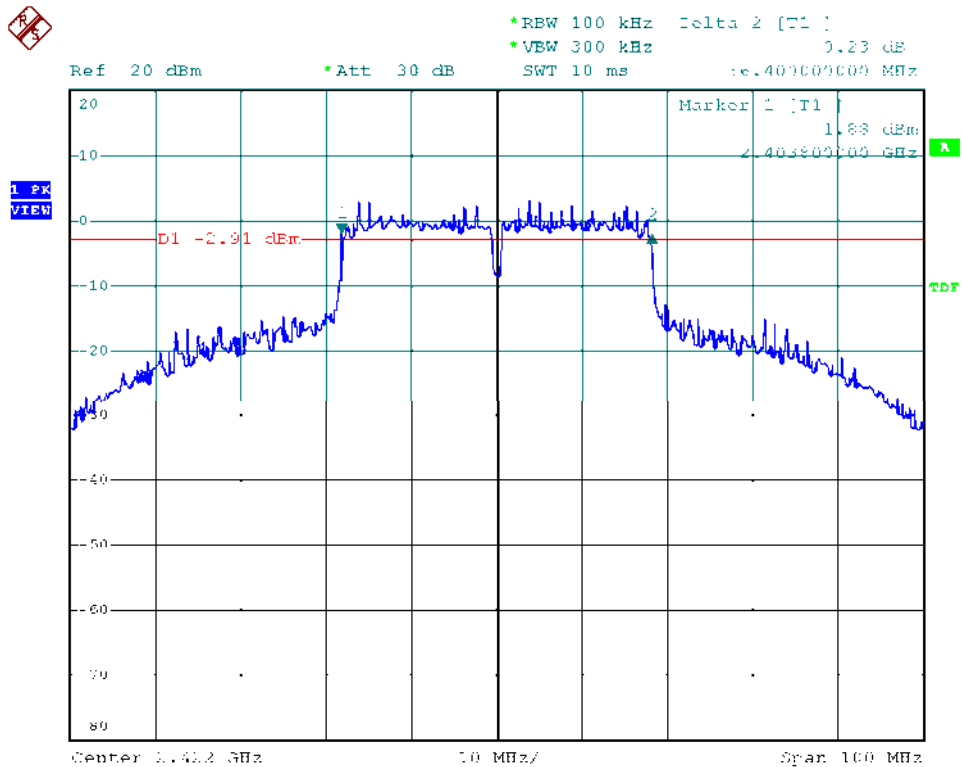



Modulation Standard: 802.11n HT40 (13.5Mbps)
Channel: 06

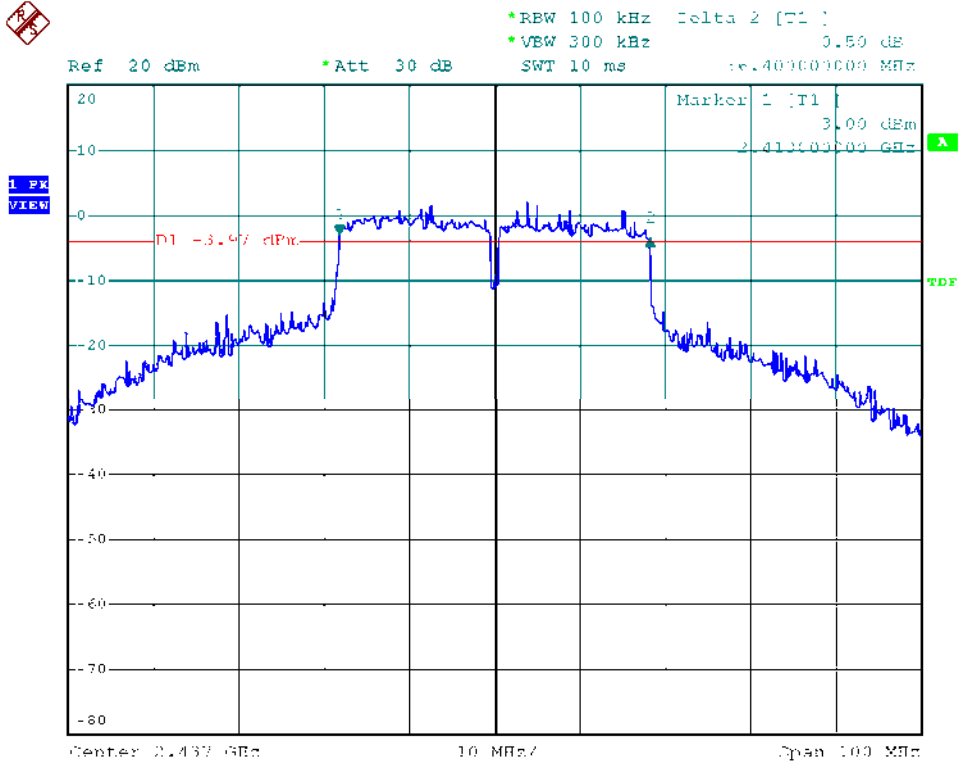

Modulation Standard: 802.11n HT40 (13.5Mbps)
Channel: 09

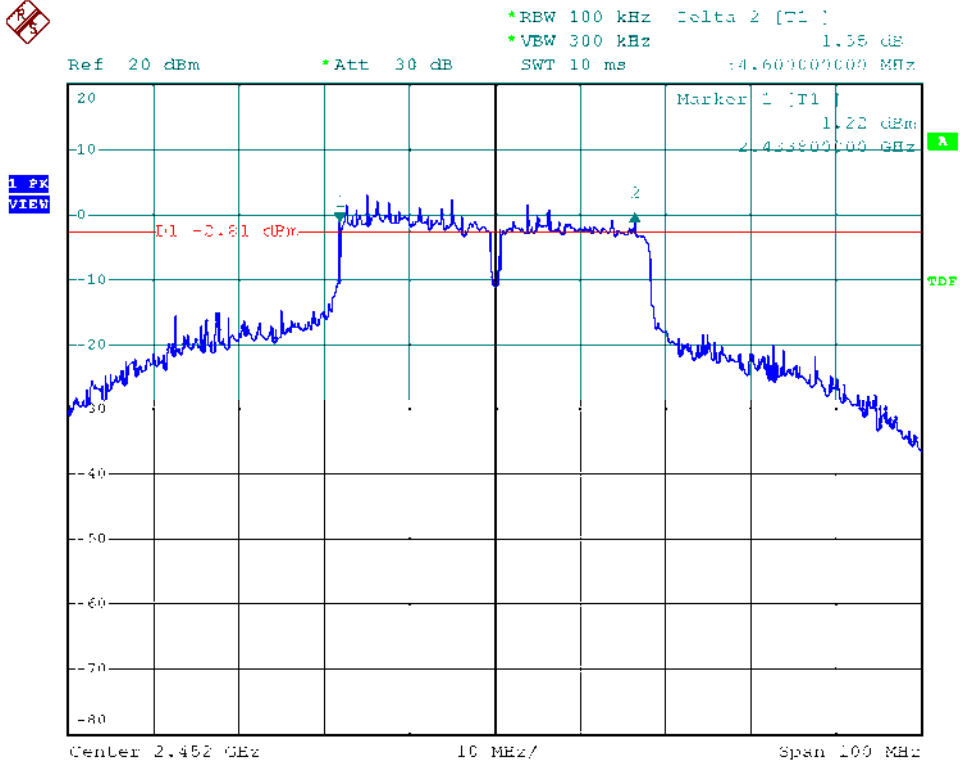



7. Maximum Peak and Average Output Power

7.1 Test Limit

The Maximum Peak Output Power Measurement is 30dBm.

7.2 Test Procedures

- a. The transmitter output was connected to the Power meter.
- b. The maximum peak and average output power was measured and recorded.

7.3 Test Setup Layout

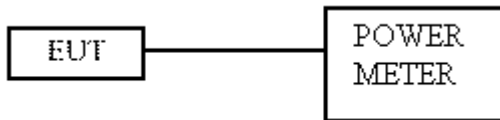

7.4 Measurement Equipment

Instrument/Ancillary	Manufacturer	Model No.	Serial No.	Calibration Date	Valid Date
Series Power Meter	ANRITSU	ML2495A	1224005	2013/03/21	2014/03/20
Power Sensor	ANRITSU	MA2411B	1207295	2013/03/21	2014/03/20



7.5 Test Result and Data

Test Date: Nov. 05, 2013

Temperature: 24°C

Atmospheric pressure: 1018 hPa

Humidity: 61%

Modulation Standard	Channel	Frequency (MHz)	Peak Power Output (dBm)		Power Output (mW)	
			Peak	Average	Peak	Average
802.11b (11Mbps)	01	2412	18.85	16.12	76.7	40.9
	06	2437	19.09	16.26	81.1	42.3
	11	2462	19.47	16.83	88.5	48.2
802.11g (6Mbps)	01	2412	18.23	10.08	66.5	10.2
	06	2437	18.22	9.73	66.4	9.4
	11	2462	18.79	10.28	75.7	10.7

Modulation Standard	Channel	Frequency (MHz)	Peak Power Output (dBm)		Power Output (mW)	
			Peak	Average	Peak	Average
802.11n HT20 (6.5Mbps)	01	2412	18.25	10.07	66.8	10.2
	06	2437	18.57	10.12	71.9	10.3
	11	2462	18.83	10.24	76.4	10.6
802.11n HT40 (13.5Mbps)	03	2422	18.13	9.49	65.0	8.9
	06	2437	18.39	9.71	69.0	9.4
	09	2452	18.25	9.35	66.8	8.6

Power parameter	CH1	CH6	CH11
802.11b	15	15.5	16
802.11g	8	8.5	9
802.11n HT20	8	9	9

Power parameter	CH3	CH6	CH9
802.11n HT40	7	8	8



8. Power Spectral Density

8.1 Test Limit

The Maximum of Power Spectral Density Measurement is 8dBm.

8.2 Test Procedures

- a. The transmitter output was connected to spectrum analyzer.
- b. The spectrum analyzer’s resolution bandwidth were set at $RBW \geq 3KHz$ and $VBW \geq 3x$ RBW as that of the fundamental frequency. Set span to at least 1.5 times the DTS channel bandwidth. Set the sweep time=auto couple.
- c. The power spectral density was measured and recorded.

8.3 Test Setup Layout

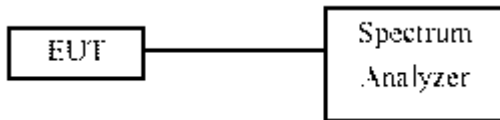

8.4 Measurement Equipment

Instrument/Ancillary	Manufacturer	Model No.	Serial No.	Calibration Date	Valid Date
Spectrum Analyzer	R&S	FSP40	100047	2013/03/15	2014/03/14

8.5 Test Result and Data

Test Date: Nov. 05, 2013

Temperature: 24°C

Atmospheric pressure: 1018 hPa

Humidity: 61%

Modulation Standard	Channel	Frequency (MHz)	Maximum Power Density of 3 kHz Bandwidth (dBm)
802.11b (11Mbps)	01	2412	-9.63
	06	2437	-9.39
	11	2462	-8.66
802.11g (6Mbps)	01	2412	-15.32
	06	2437	-16.87
	11	2462	-15.67
802.11n HT20 (6.5Mbps)	01	2412	-16.48
	06	2437	-15.34
	11	2462	-16.94
802.11n HT40 (13.5Mbps)	03	2422	-19.69
	06	2437	-18.81
	09	2452	-17.61



Modulation Standard: 802.11b (11Mbps)
Channel: 01

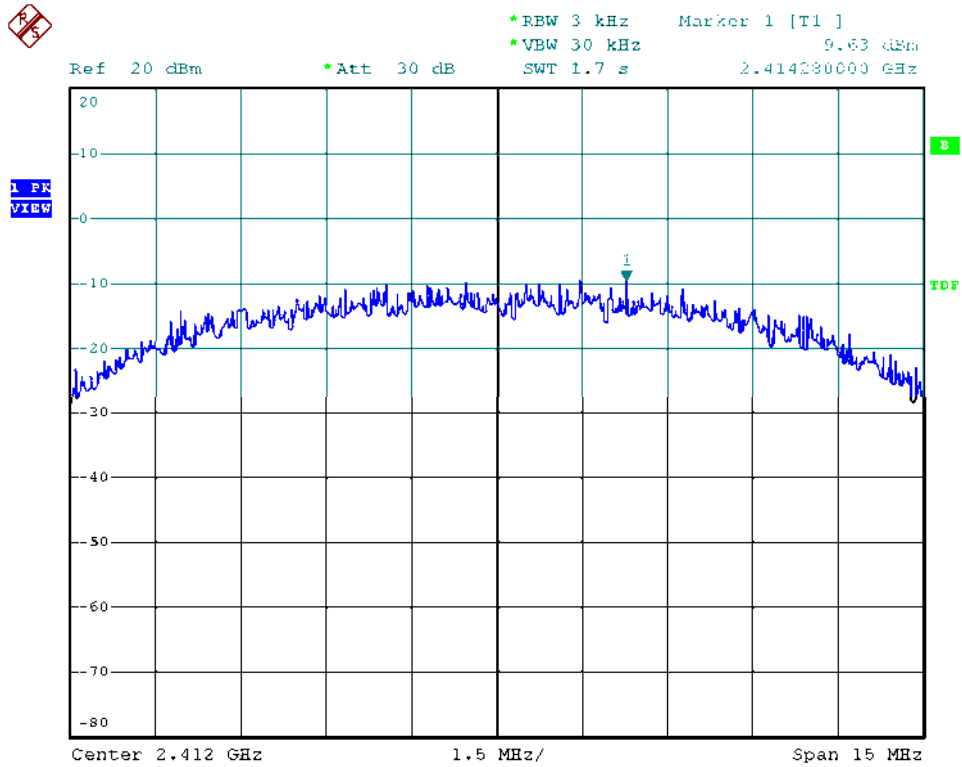

Modulation Standard: 802.11b (11Mbps)
Channel: 06

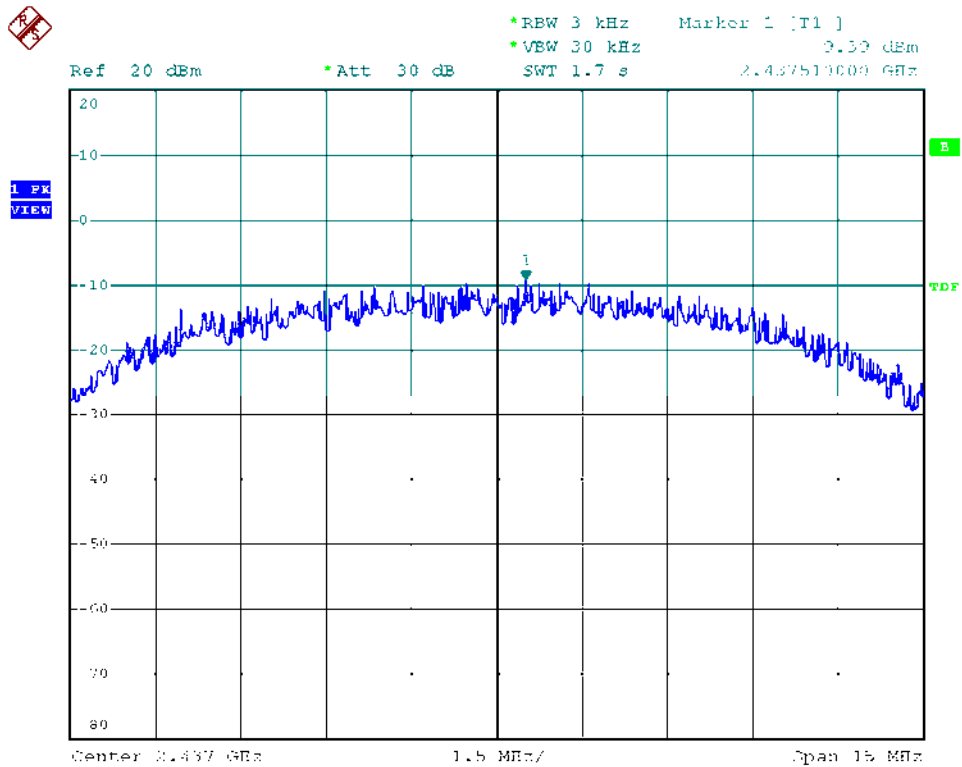



Modulation Standard: 802.11b (11Mbps)
Channel: 11

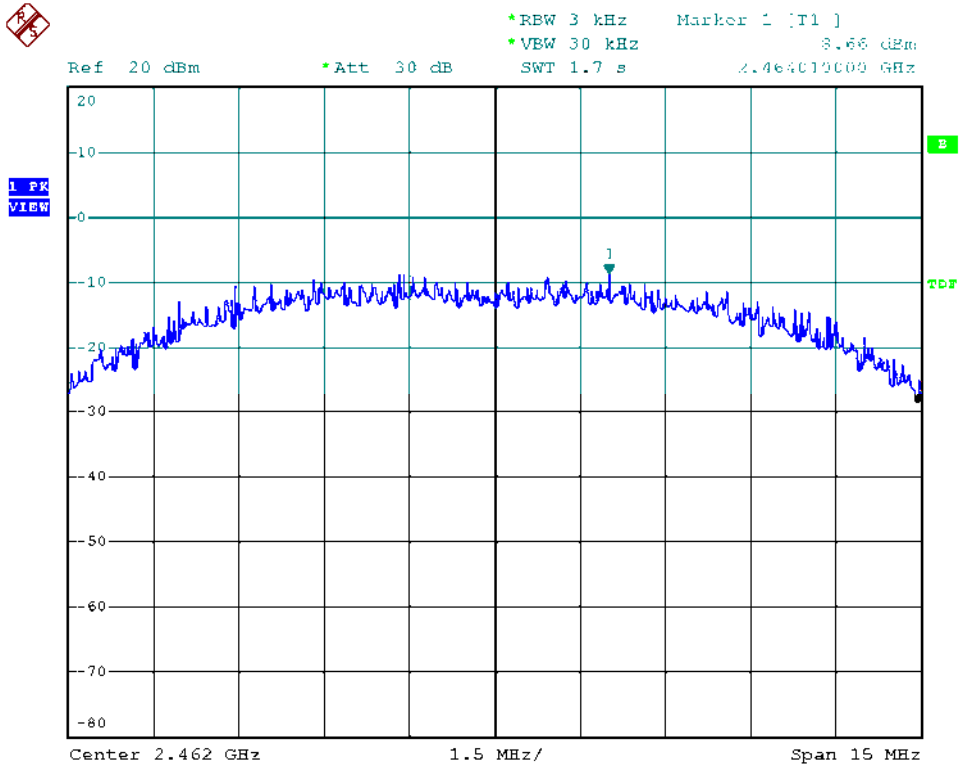

Modulation Standard: 802.11g (6Mbps)
Channel: 01

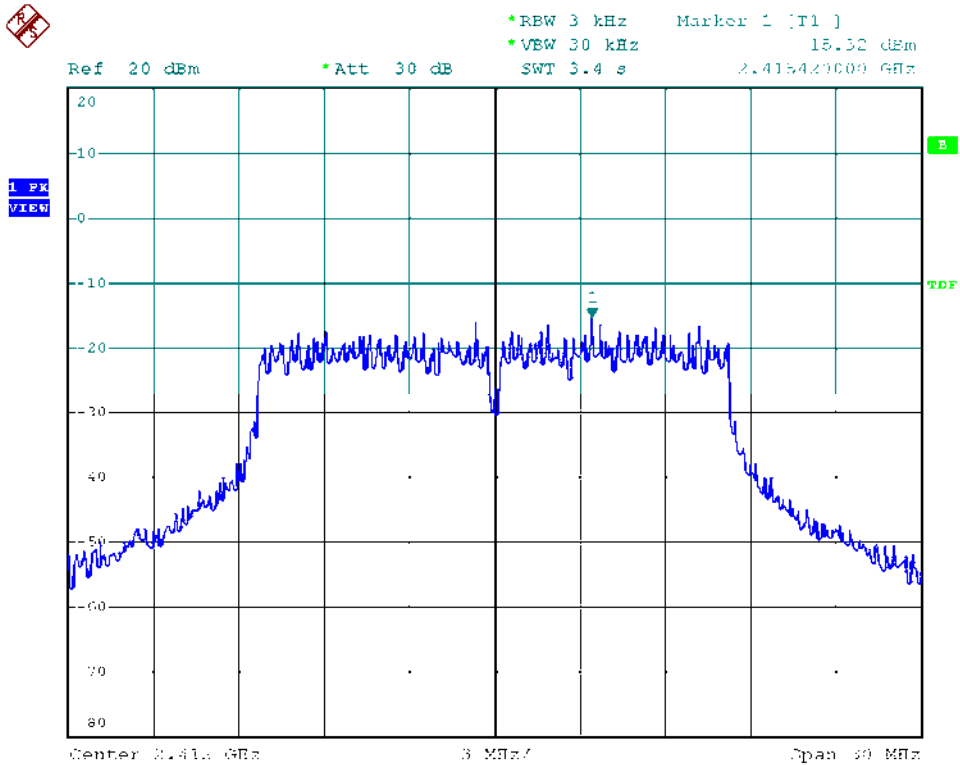



Modulation Standard: 802.11g (6Mbps)
Channel: 06

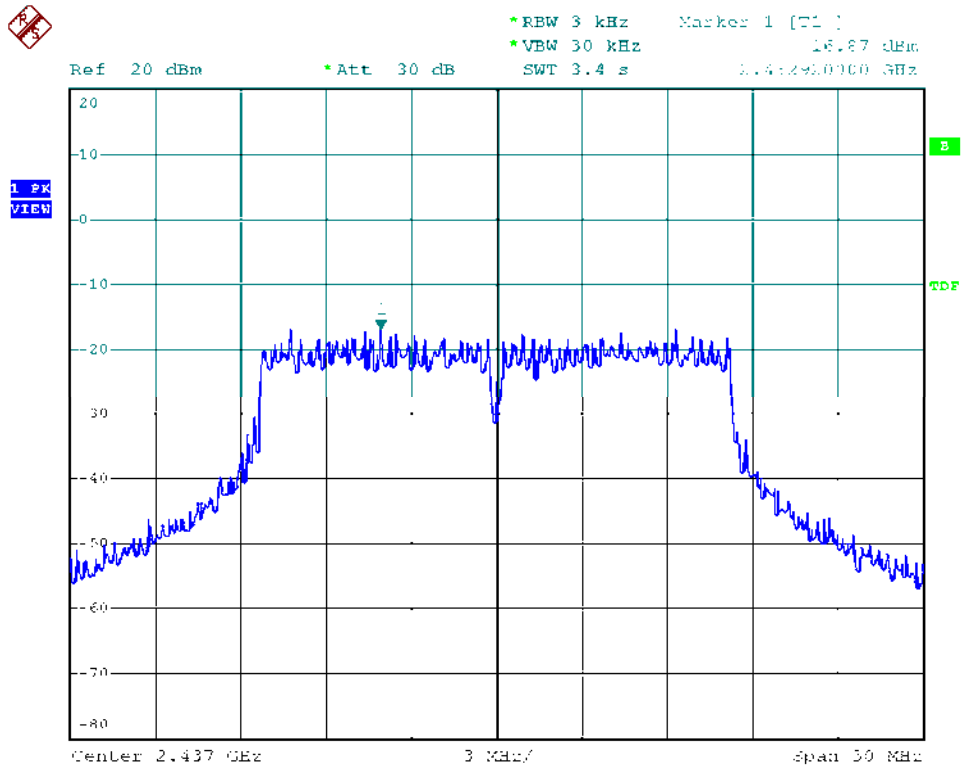

Modulation Standard: 802.11g (6Mbps)
Channel: 11

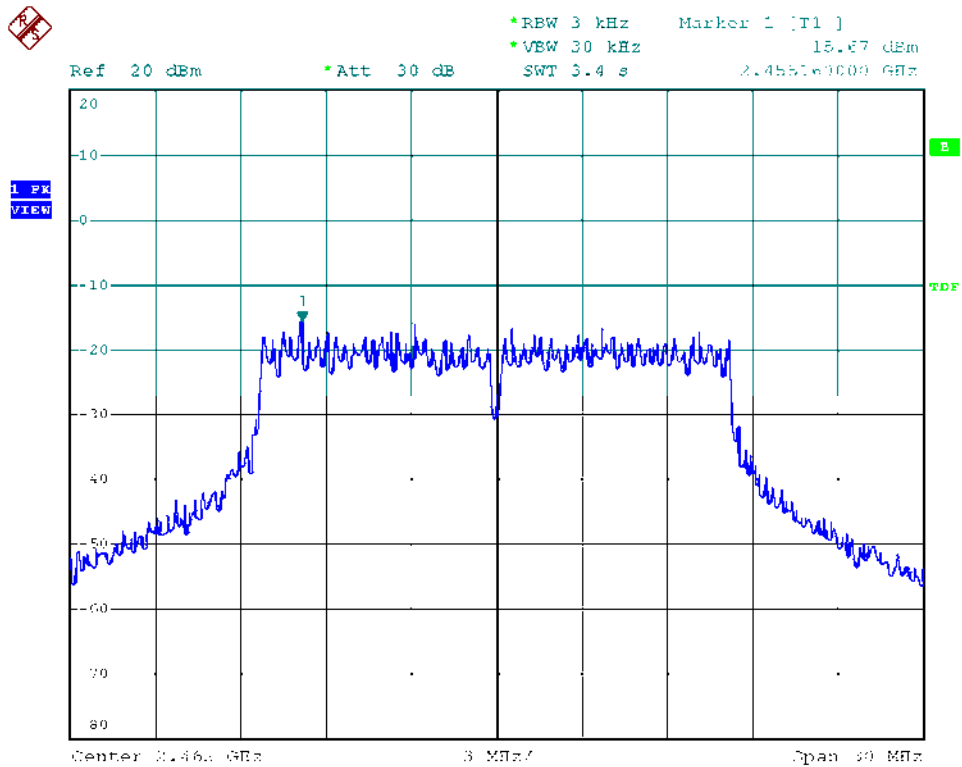



Modulation Standard: 802.11n HT20 (6.5Mbps)
Channel: 01

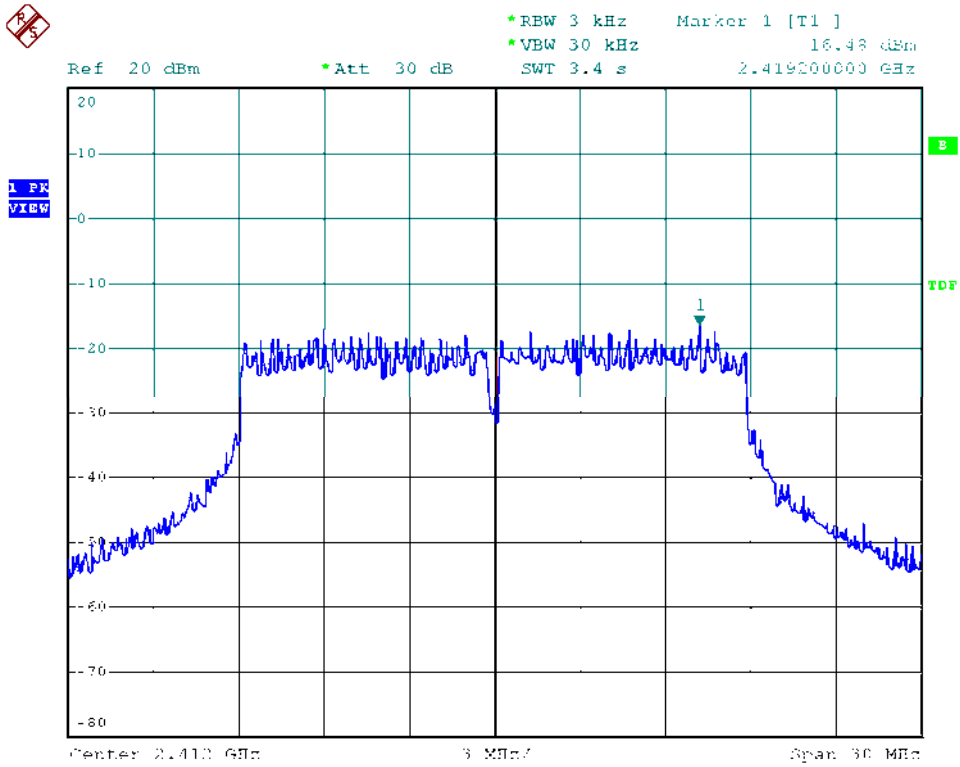

Modulation Standard: 802.11n HT20 (6.5Mbps)
Channel: 06

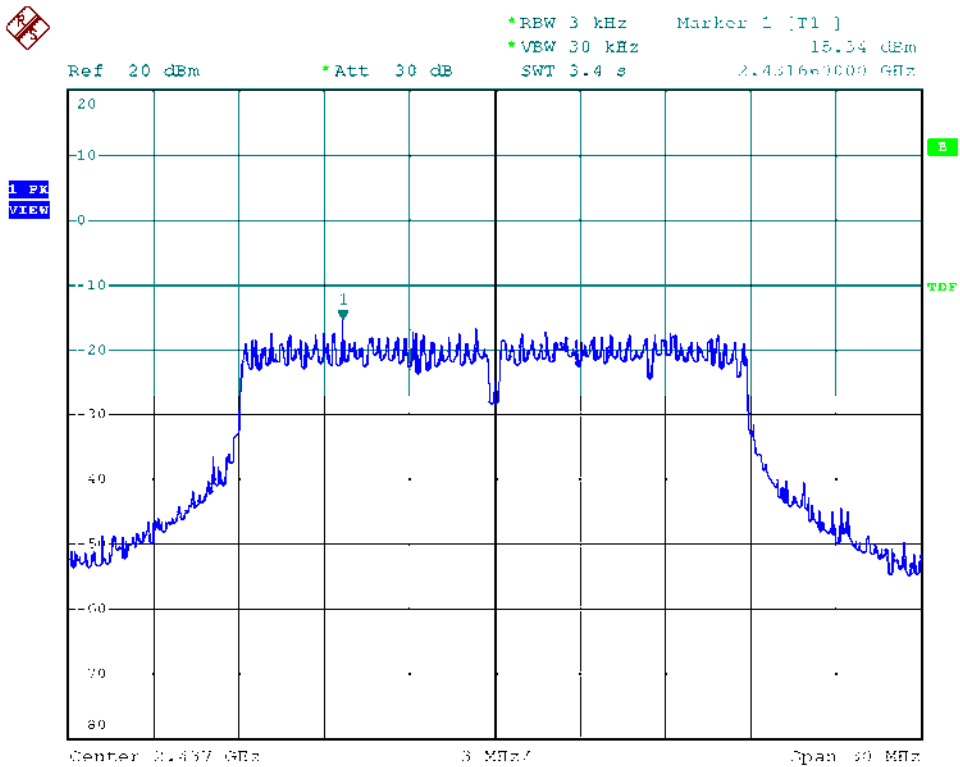



Modulation Standard: 802.11n HT20 (6.5Mbps)
Channel: 11

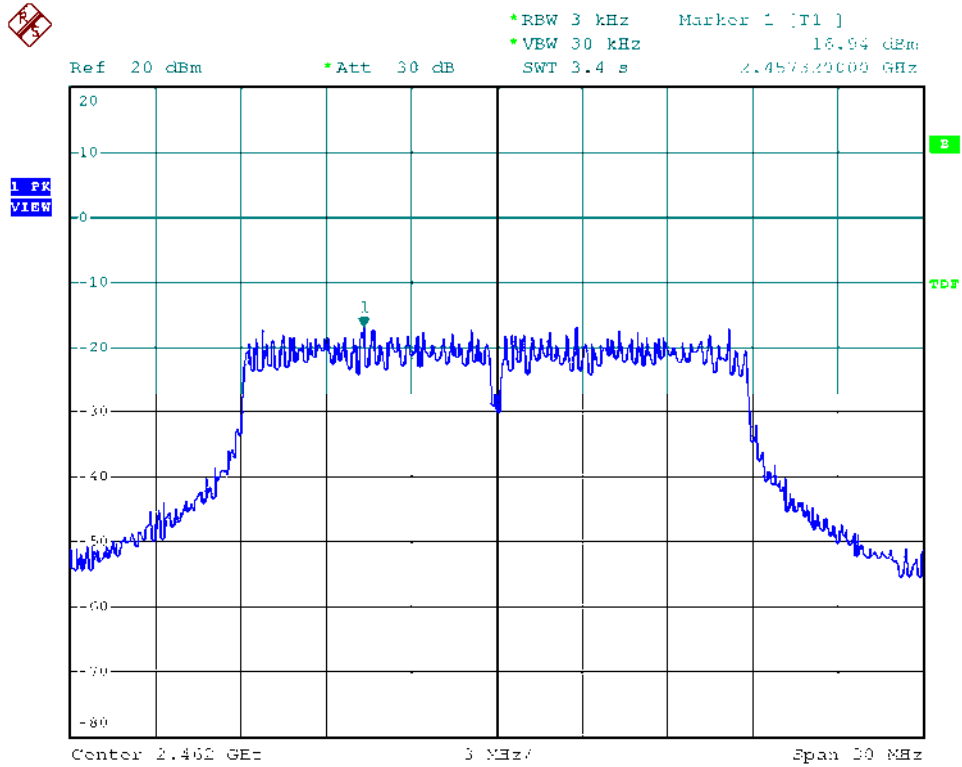

Modulation Standard: 802.11n HT40 (13.5Mbps)
Channel: 03

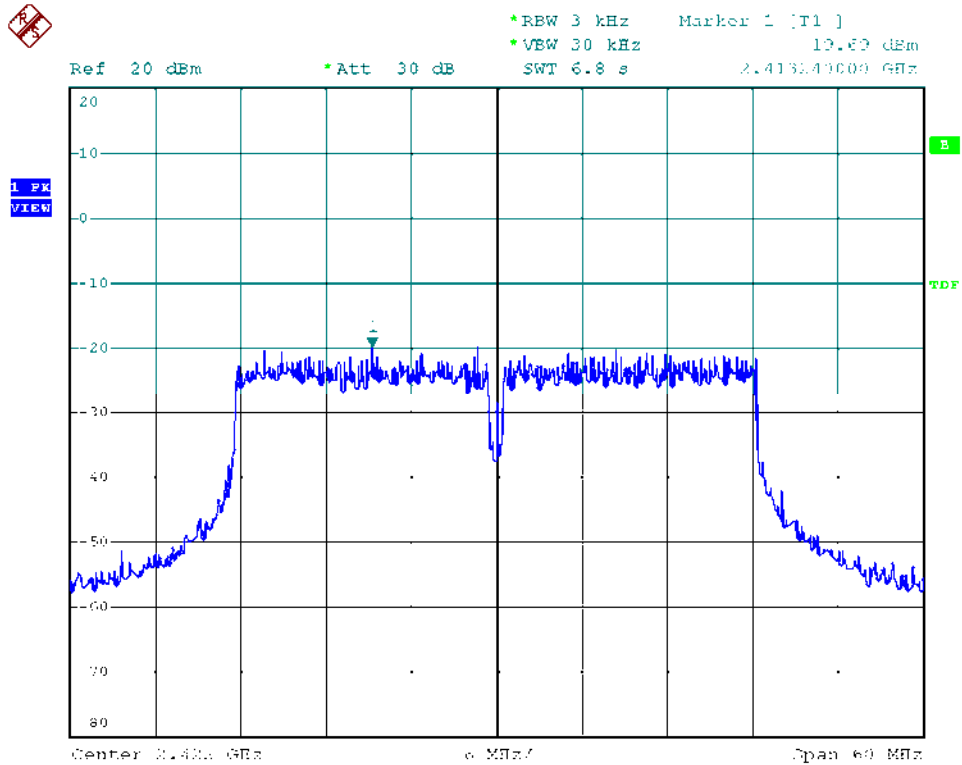



Modulation Standard: 802.11n HT40 (13.5Mbps)
Channel: 06

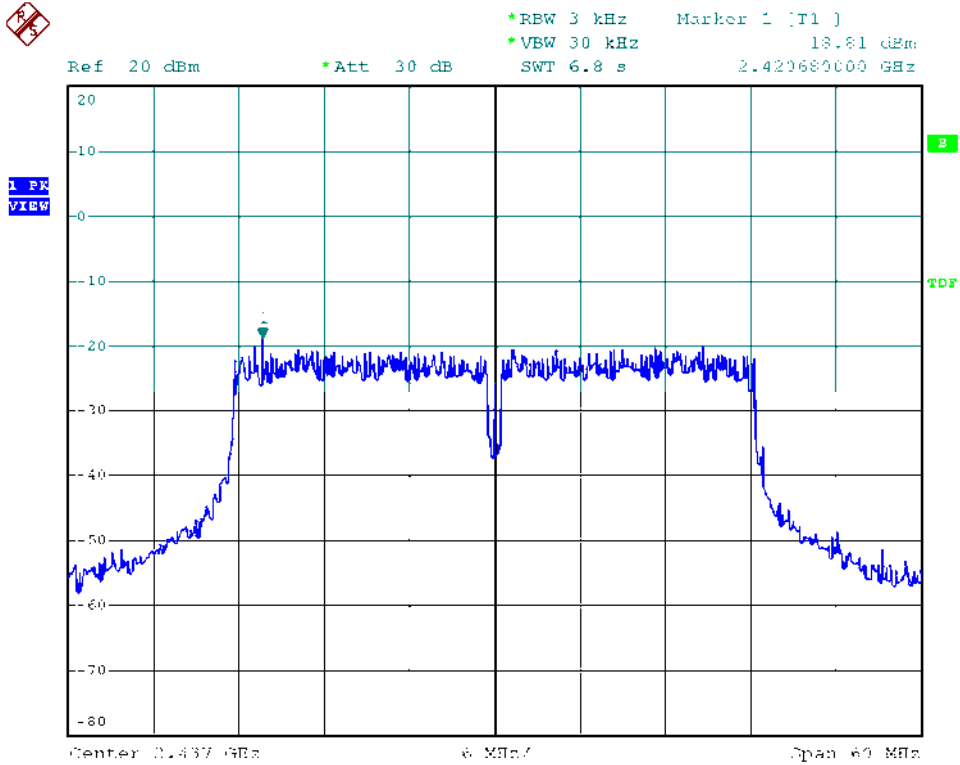

Modulation Standard: 802.11n HT40 (13.5Mbps)
Channel: 09

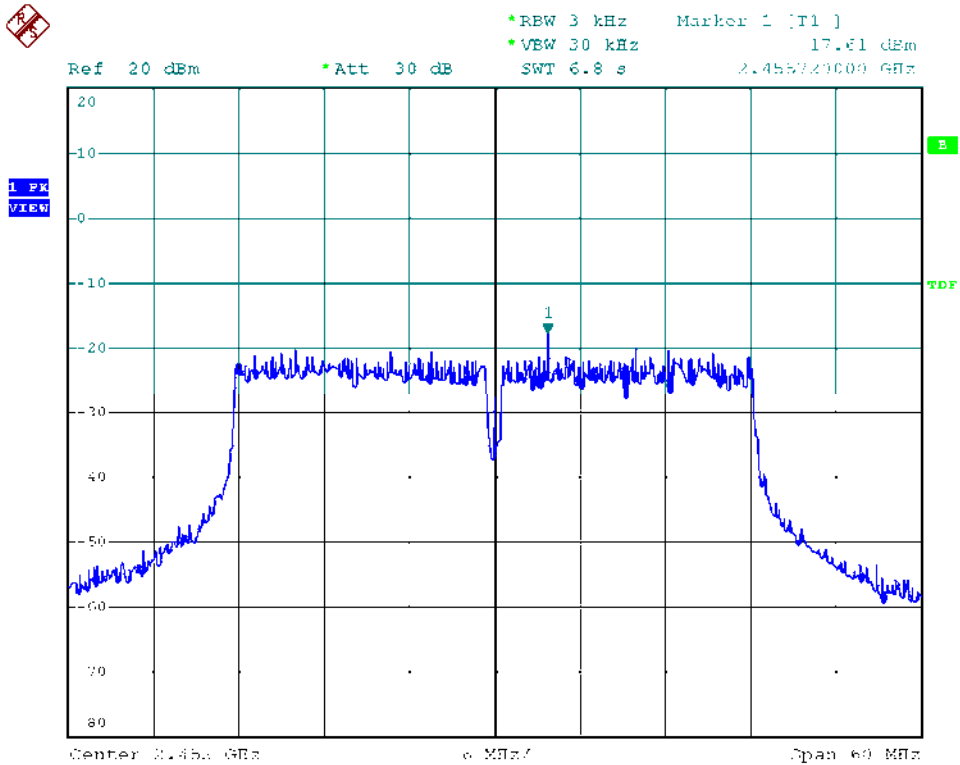



9. Band Edges Measurement

9.1 Test Limit

Below -20dB of the highest emission level of operating band (In 100 kHz Resolution Bandwidth)

9.2 Test Procedure

- The transmitter output was connected to the spectrum analyzer via a low lose cable.
- Set RBW of spectrum analyzer to 100 KHz and VBW of spectrum analyzer to 300 KHz with convenient frequency span including 100 KHz bandwidth from band edge.
- Peak conducted output power measured within any 100 kHz outside the authorized frequency band shall be attenuated by at least 20dB relative to the maximum measured in-band peak PSD level.
- The band edges was measured and recorded.

9.3 Test Setup Layout

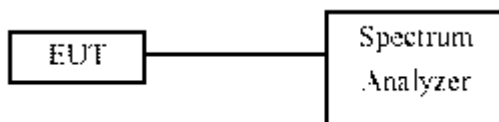

9.4 Measurement Equipment

Instrument/Ancillary	Manufacturer	Model No.	Serial No.	Calibration Date	Valid Date
Spectrum Analyzer	R&S	FSP40	100047	2013/03/15	2014/03/14

9.5 Test Result and Data

Test Date: Nov. 05, 2013

Temperature: 24°C

Atmospheric pressure: 1018 hPa

Humidity: 61%

Modulation Standard	Channel	Frequency (MHz)	maximum value in frequency (MHz)	maximum value (dBm)	Limit (dBm)
802.11b (11Mbps)	01	2412	2397.60	-20.92	-10.16
	11	2462	4795.00	-39.52	-11.84
802.11g (6Mbps)	01	2412	2399.00	-21.22	-18.29
	11	2462	2483.50	-32.03	-17.81
802.11n HT20 (6.5Mbps)	01	2412	2399.60	-16.98	-16.10
	11	2462	2483.50	-29.25	-17.03
802.11n HT40 (13.5Mbps)	03	2422	2399.60	-19.51	-18.74
	09	2452	2484.50	-24.56	-19.34



Modulation Standard: 802.11b (11Mbps)
Channel: 01

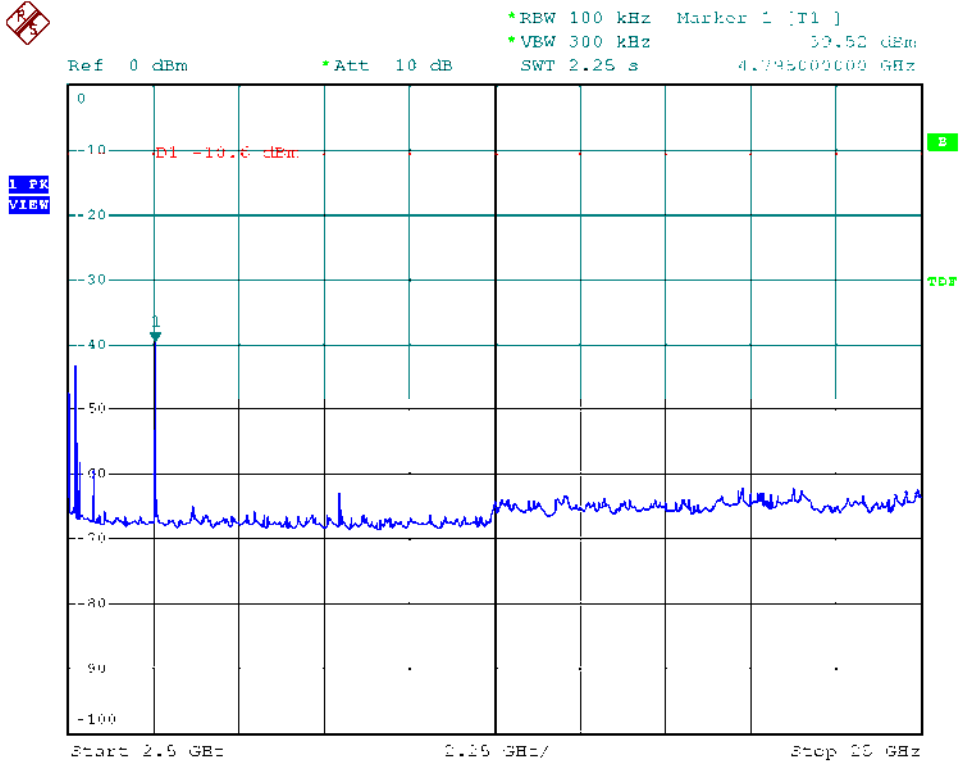
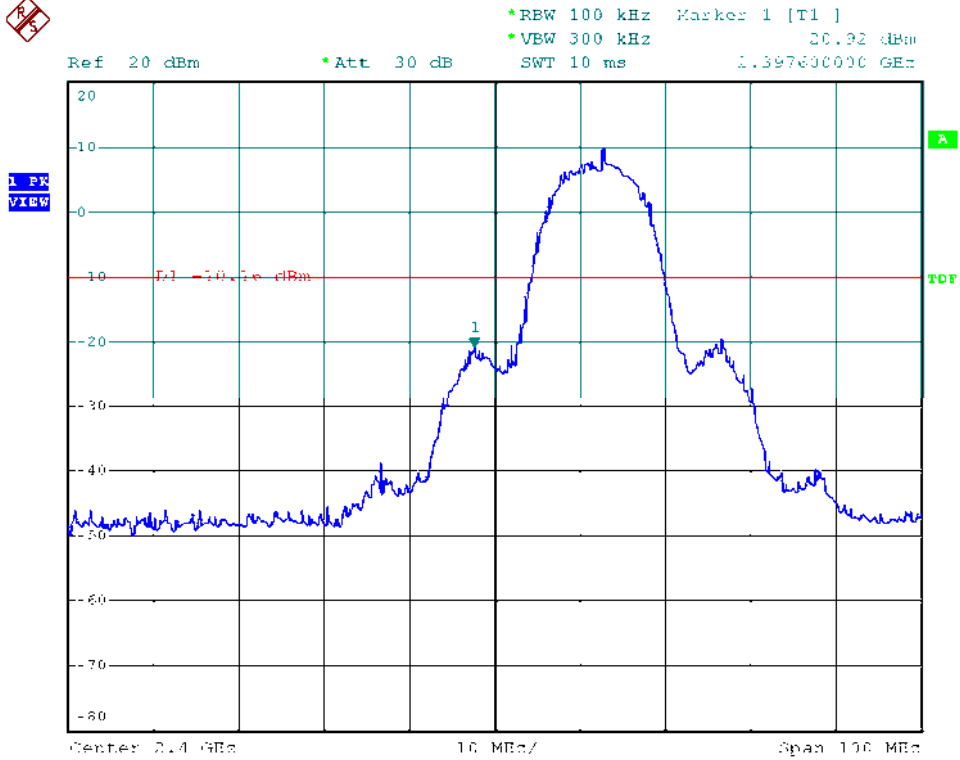



Modulation Standard: 802.11b (11Mbps)
Channel: 11

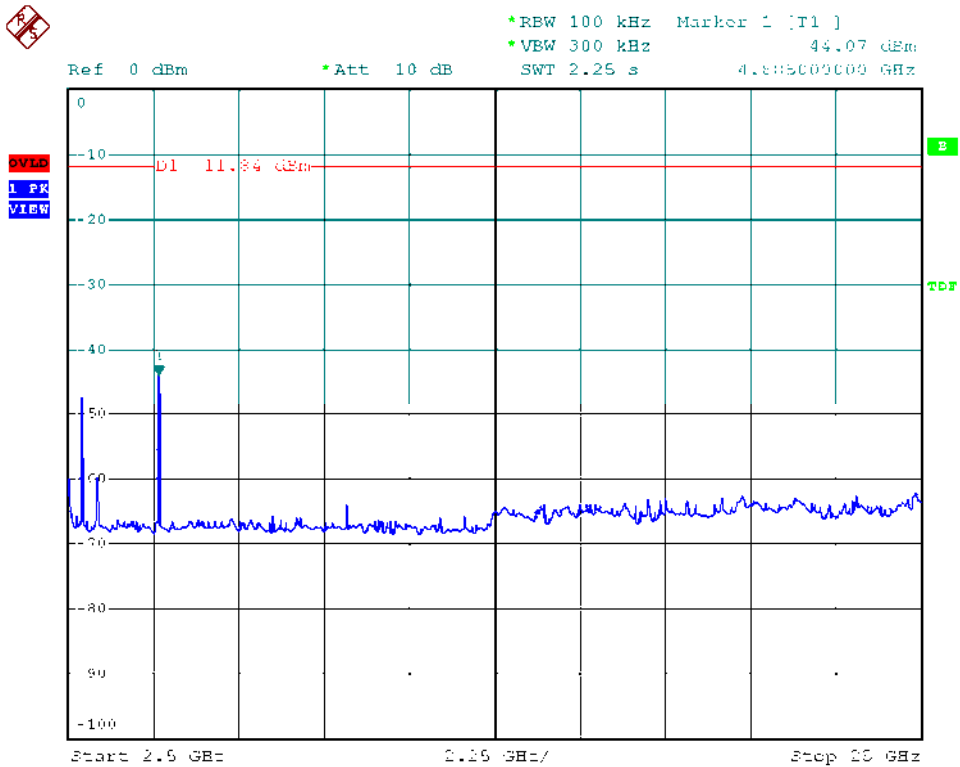
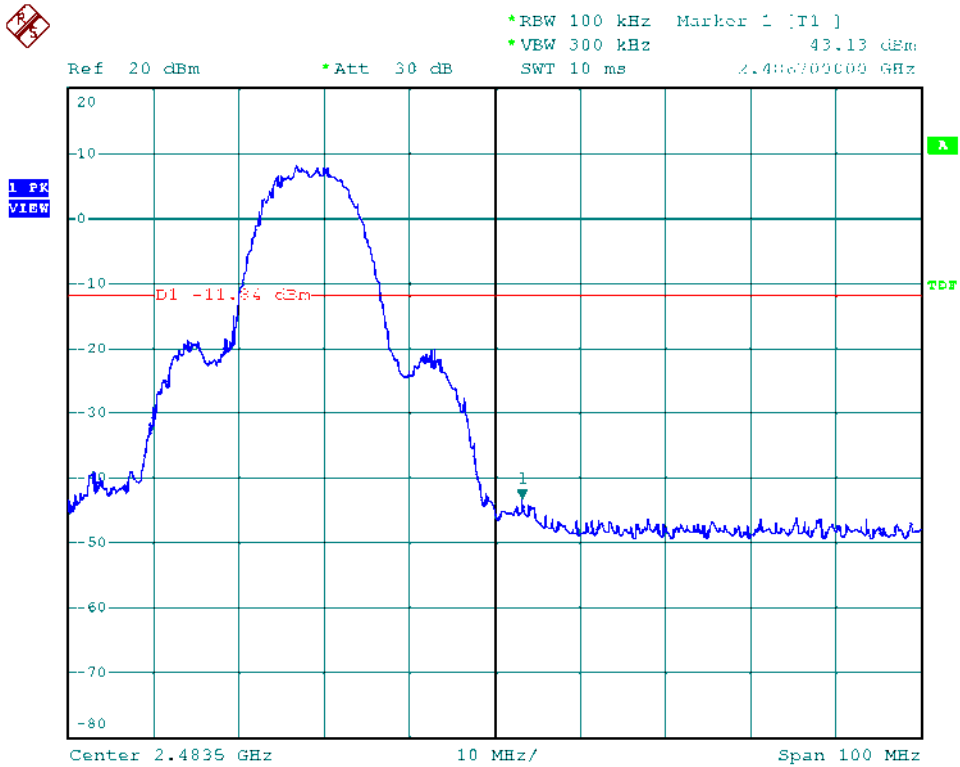



Modulation Standard: 802.11g (6Mbps)
Channel: 01

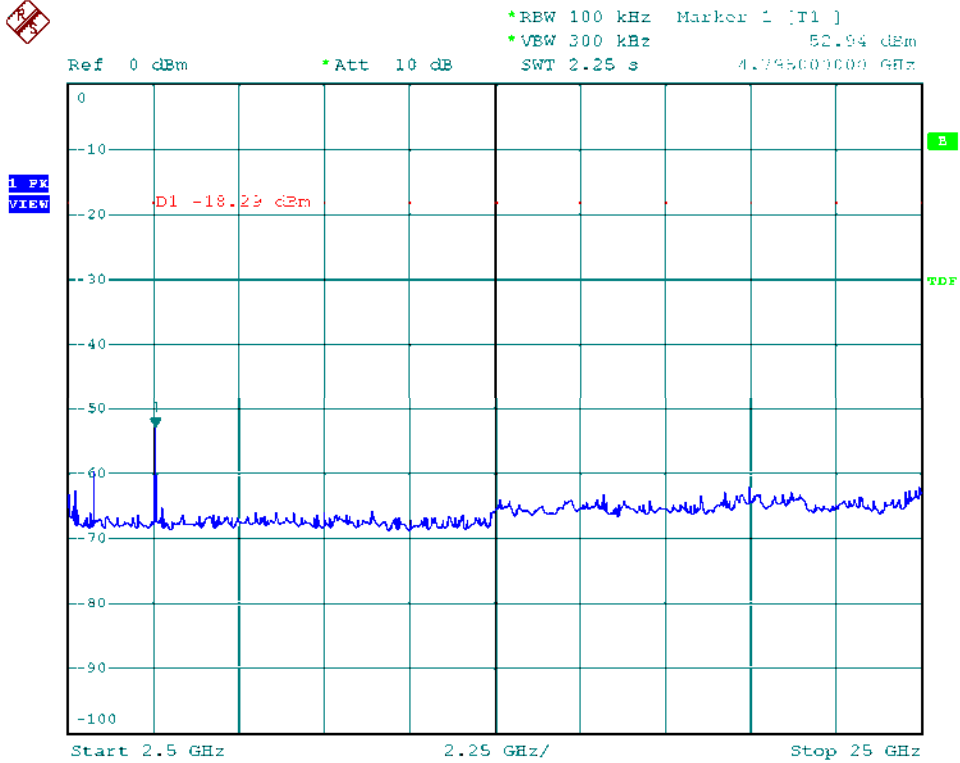
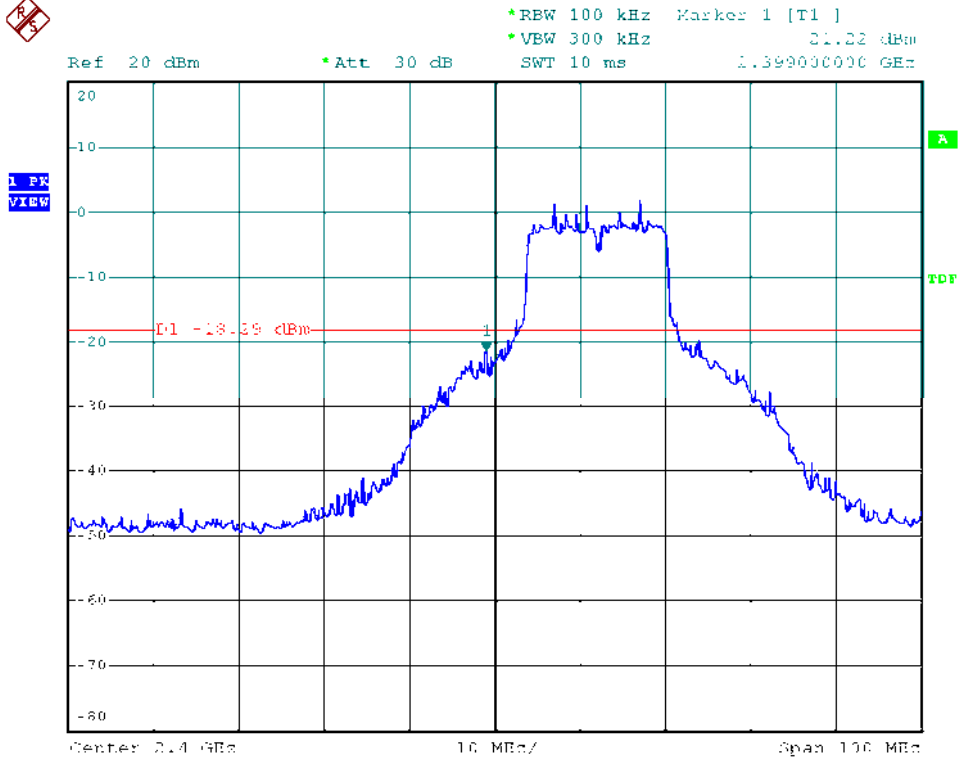



Modulation Standard: 802.11g (6Mbps)
Channel: 11

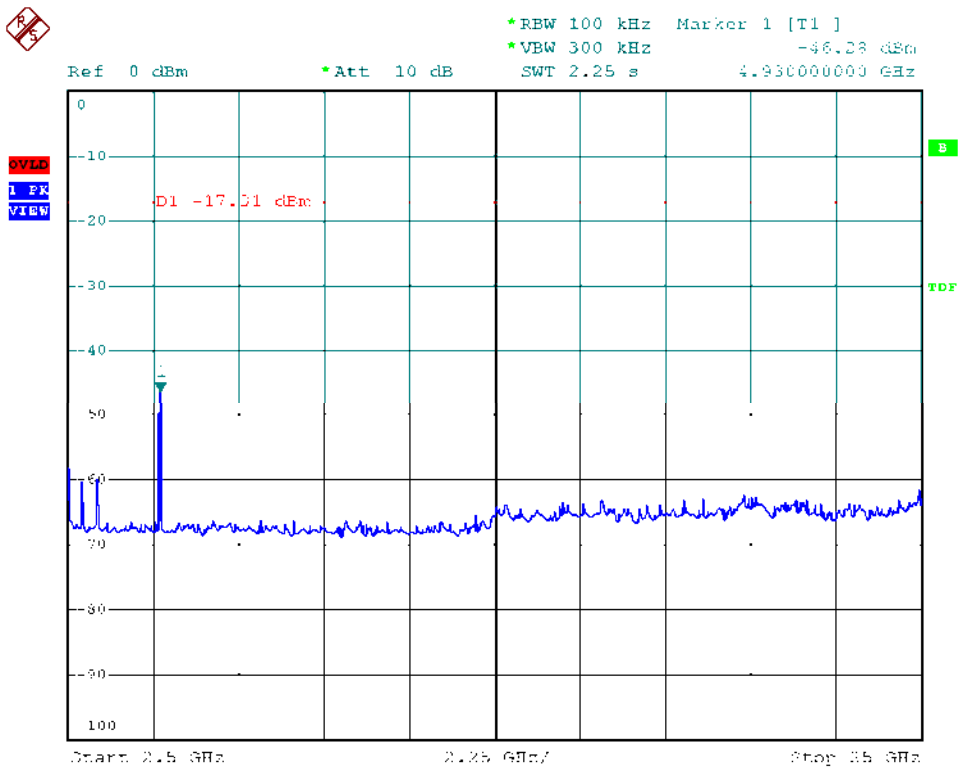
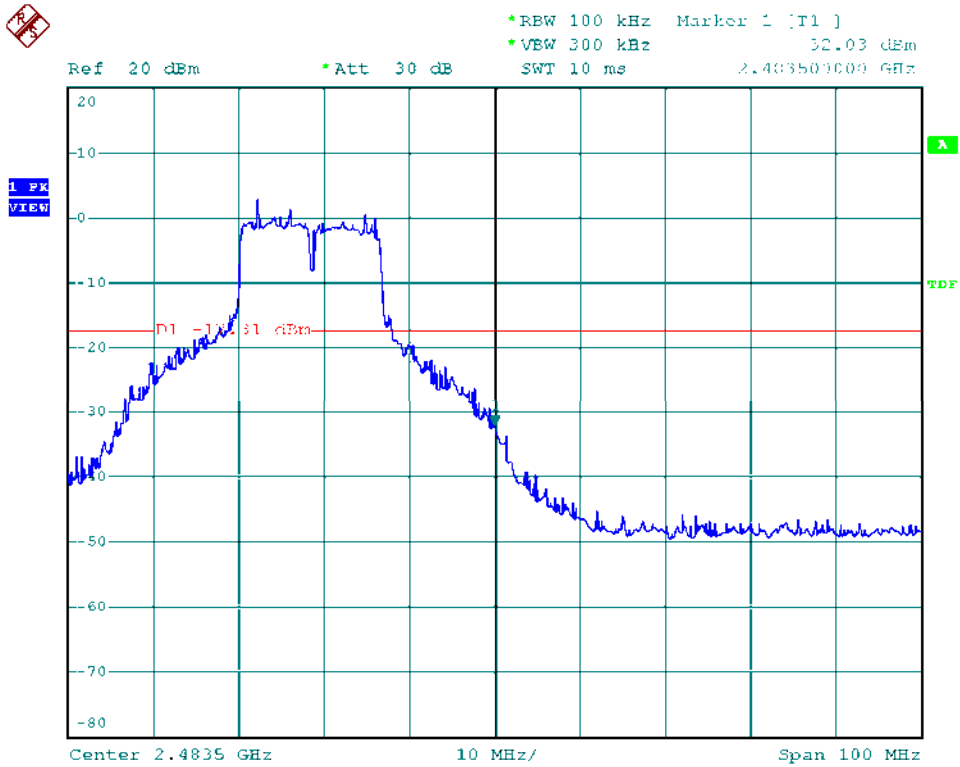



Modulation Standard: 802.11n HT20 (6.5Mbps)
Channel: 01

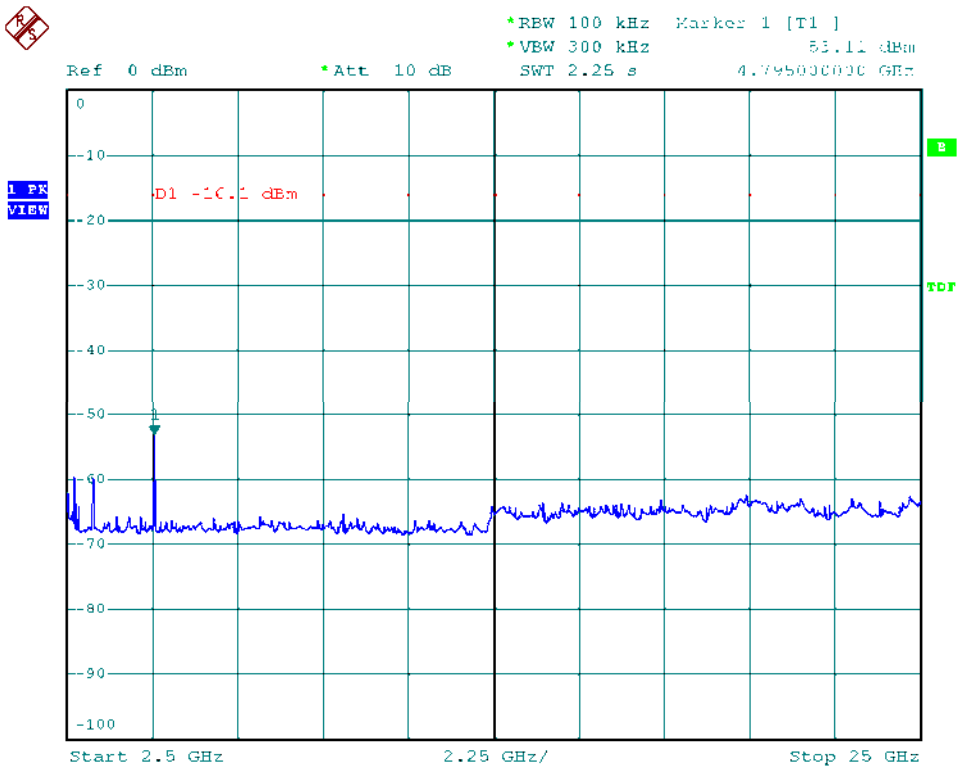
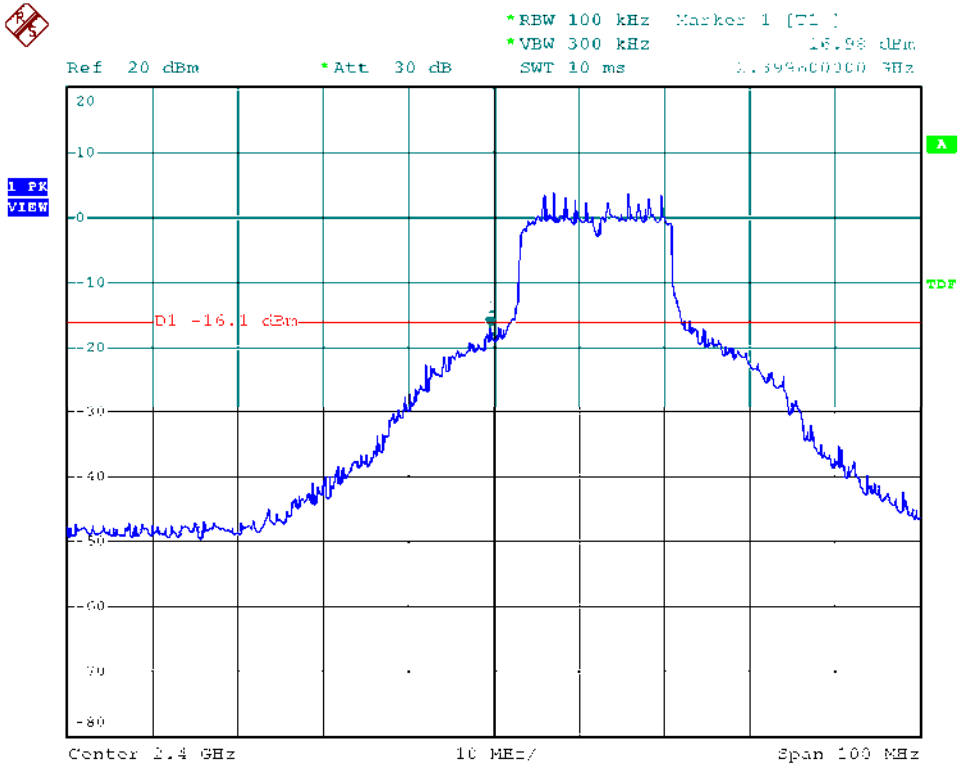



Modulation Standard: 802.11n HT20 (6.5Mbps)
Channel: 11

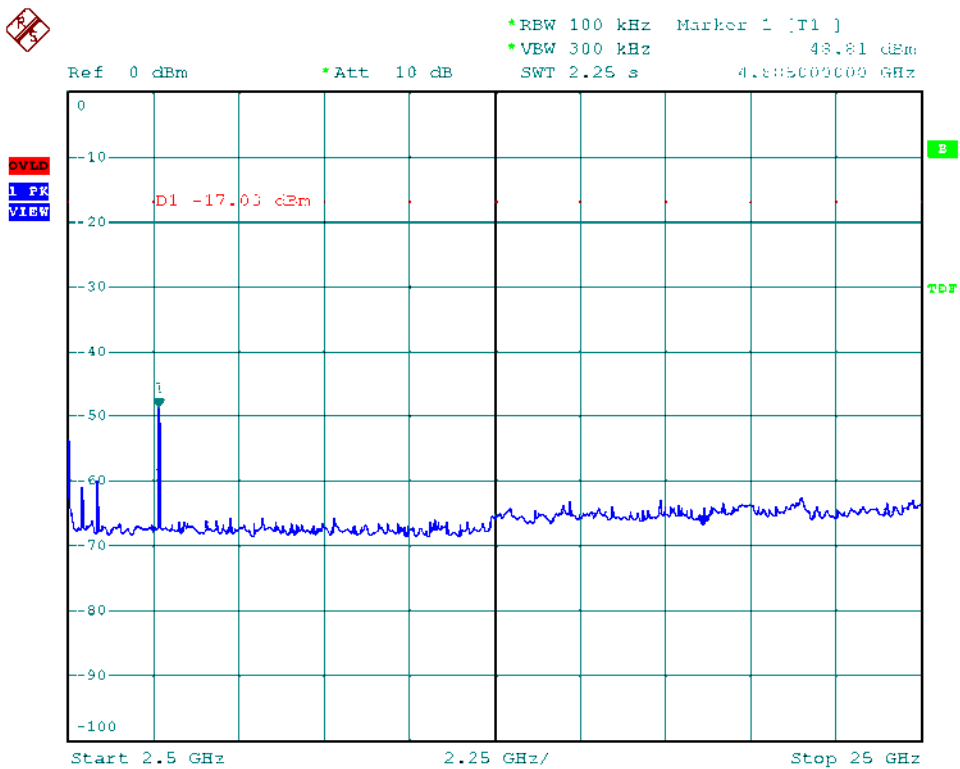
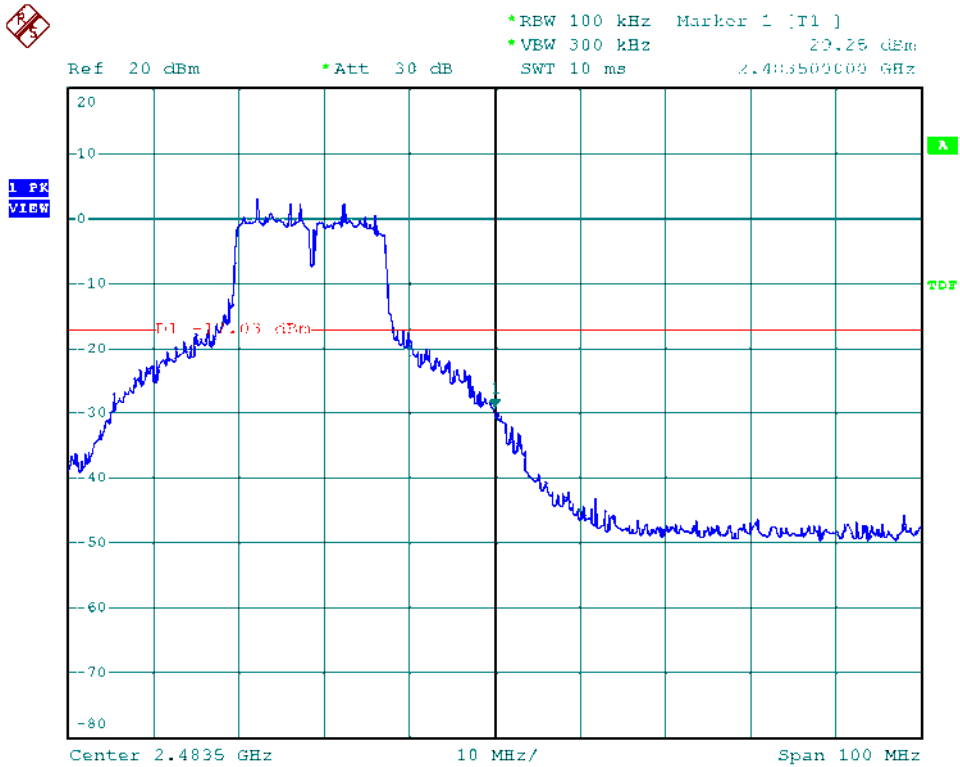



Modulation Standard: 802.11n HT40 (13.5Mbps)
Channel: 03

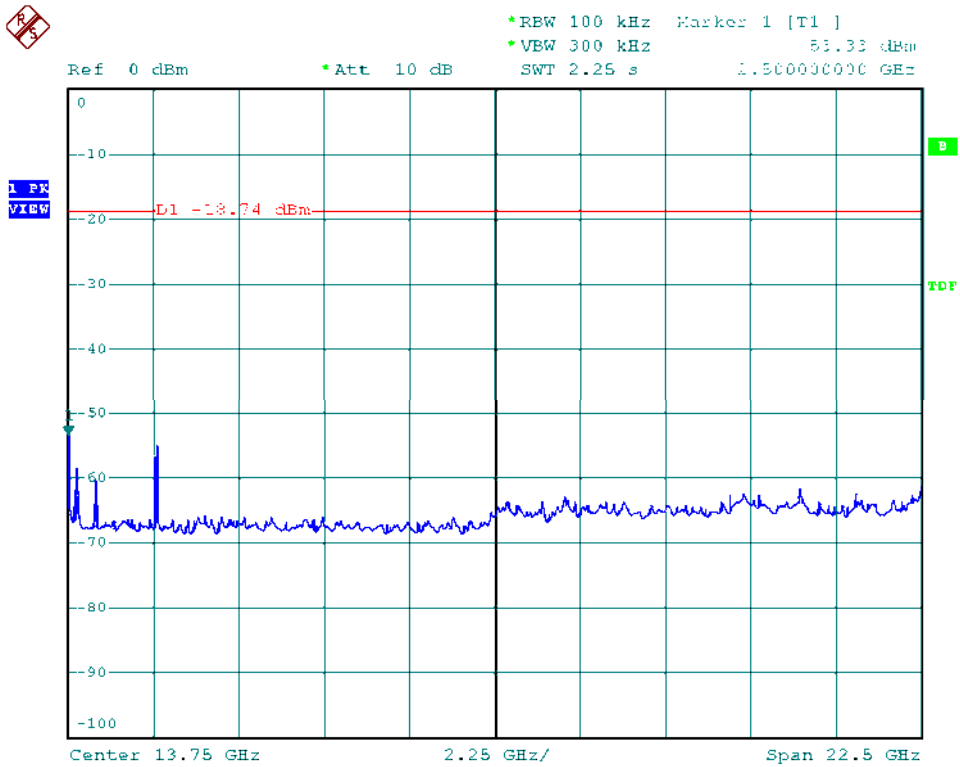
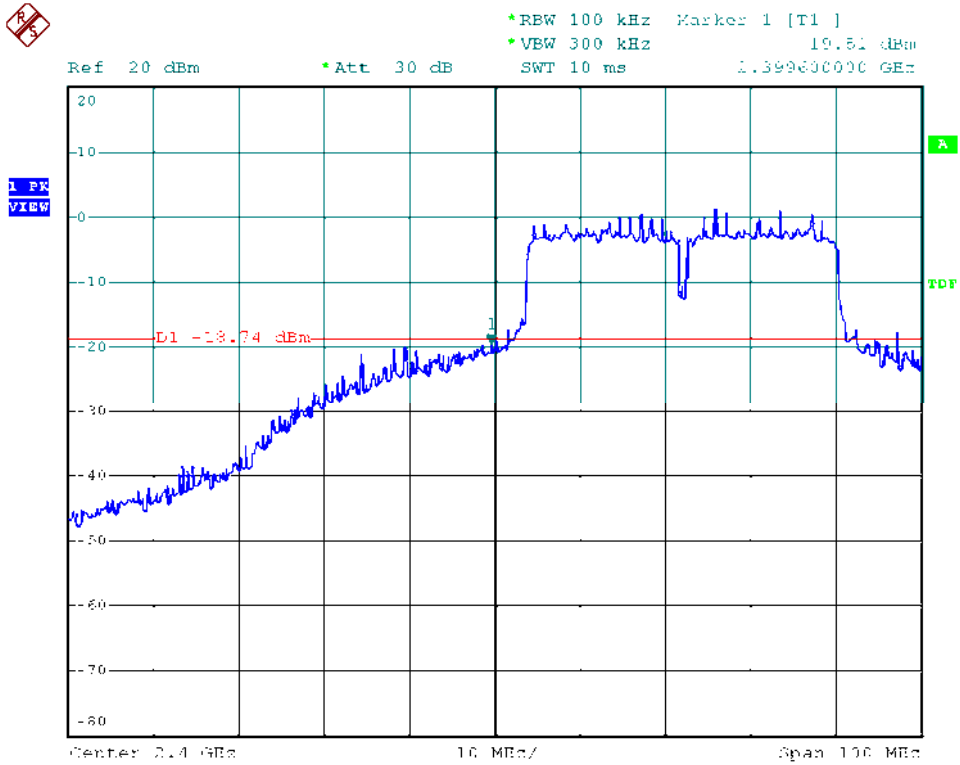



Modulation Standard: 802.11n HT40 (13.5Mbps)
Channel: 09

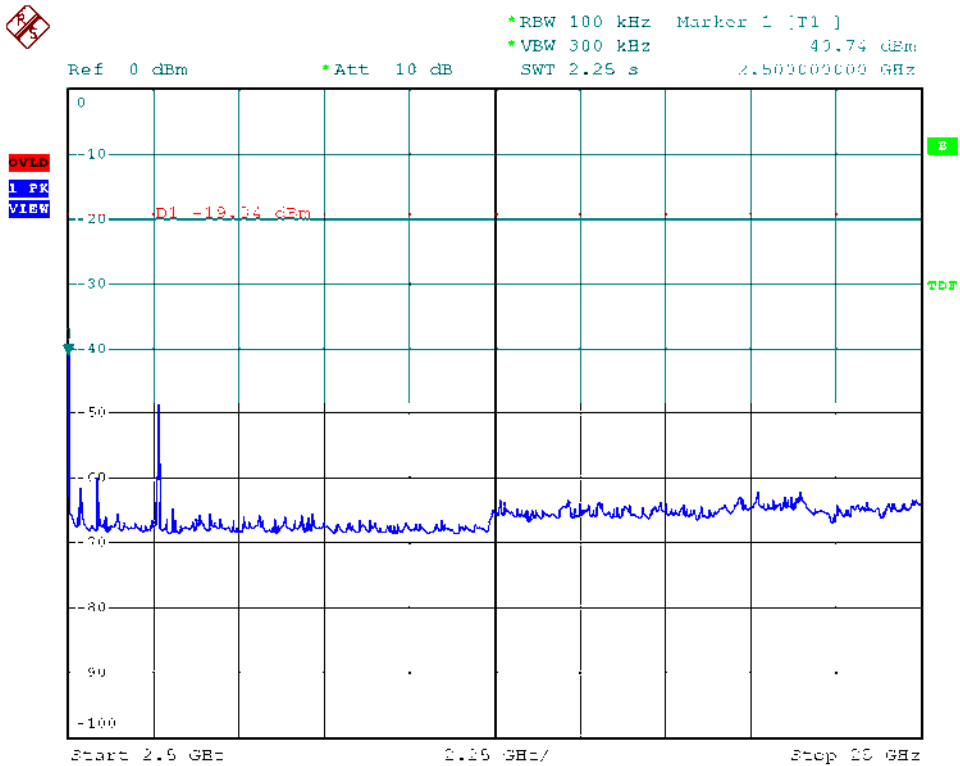
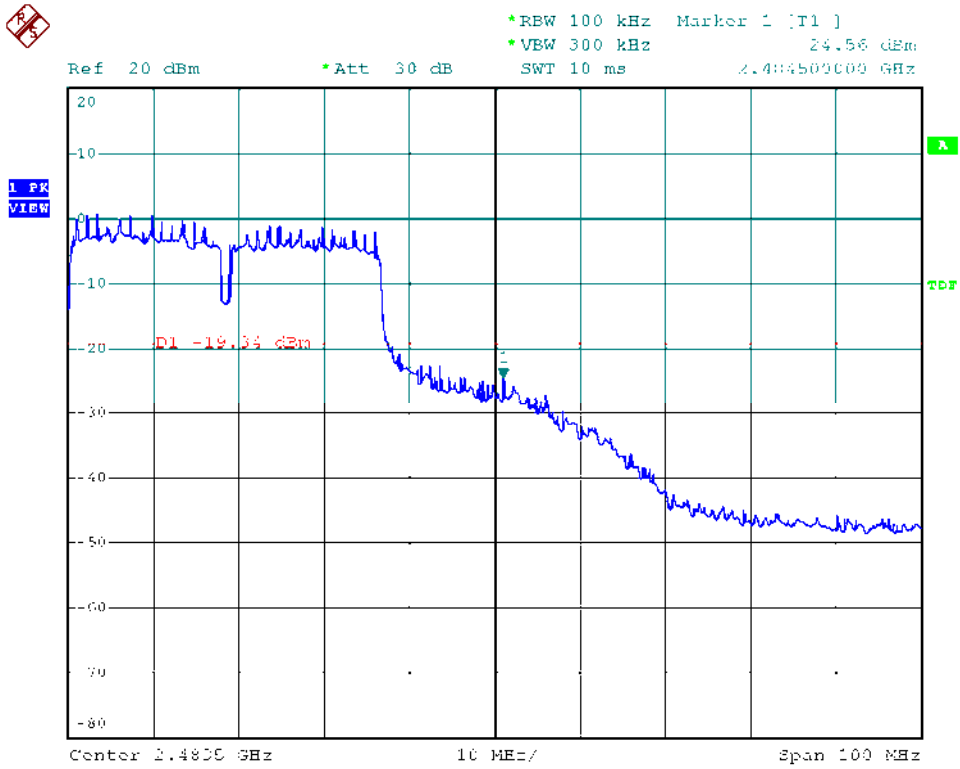



9.6 Restrict Band Emission Measurement Data

Test Date: Nov. 08, 2013

Temperature: 24°C

Atmospheric pressure: 1018 hPa

Humidity: 61%

Modulation Standard: IEEE 802.11b (11Mbps)

Channel 1						Fundamental Frequency: 2412 MHz				
Frequency (MHz)	Ant-Pol H/V	Meter Reading (dBuV)	Corrected Factor (dB)	Result (dBuV/m)	Remark	Limit (dBuV/m)		Margin (dB)	Table Deg.	Ant High (m)
						Peak	Ave			
2385.48	H	58.18	1.81	59.99	Peak	74	54	-14.01	120	1.00
2386.25	H	46.98	1.80	48.78	Ave	74	54	-5.22	120	1.00
2385.99	V	61.37	2.49	63.86	Peak	74	54	-10.14	212	1.00
2386.76	V	48.74	2.47	51.21	Ave	74	54	-2.79	212	1.00
Channel 11						Fundamental Frequency: 2462 MHz				
Frequency (MHz)	Ant-Pol H/V	Meter Reading (dBuV)	Corrected Factor (dB)	Result (dBuV/m)	Remark	Limit (dBuV/m)		Margin (dB)	Table Deg.	Ant High (m)
						Peak	Ave			
2483.74	H	58.70	0.49	59.19	Peak	74	54	-14.81	120	1.00
2483.57	H	47.20	0.50	47.70	Ave	74	54	-6.30	120	1.00
2484.80	V	63.43	-2.22	61.21	Peak	74	54	-12.79	201	1.00
2486.42	V	50.62	-2.30	48.32	Ave	74	54	-5.68	201	1.00

Modulation Standard: IEEE 802.11g (6Mbps)

Channel 1						Fundamental Frequency: 2412 MHz				
Frequency (MHz)	Ant-Pol H/V	Meter Reading (dBuV)	Corrected Factor (dB)	Result (dBuV/m)	Remark	Limit (dBuV/m)		Margin (dB)	Table Deg.	Ant High (m)
						Peak	Ave			
2382.42	H	57.99	1.82	59.81	Peak	74	54	-14.19	122	1.00
2389.82	H	47.06	1.80	48.86	Ave	74	54	-5.14	122	1.00
2389.76	V	66.11	2.43	68.54	Peak	74	54	-5.46	212	1.00
2389.31	V	49.04	2.43	51.47	Ave	74	54	-2.53	212	1.00
Channel 11						Fundamental Frequency: 2462 MHz				
Frequency (MHz)	Ant-Pol H/V	Meter Reading (dBuV)	Corrected Factor (dB)	Result (dBuV/m)	Remark	Limit (dBuV/m)		Margin (dB)	Table Deg.	Ant High (m)
						Peak	Ave			
2486.89	H	58.10	0.44	58.54	Peak	74	54	-15.46	120	1.00
2483.57	H	47.30	0.50	47.80	Ave	74	54	-6.20	120	1.00
2483.55	V	69.24	-2.15	67.09	Peak	74	54	-6.91	202	1.00
2483.57	V	51.56	-2.15	49.41	Ave	74	54	-4.59	202	1.00



Modulation Standard: IEEE 802.11n HT20 (6.5Mbps)

Channel 1						Fundamental Frequency: 2412 MHz				
Frequency (MHz)	Ant-Pol H/V	Meter Reading (dBuV)	Corrected Factor (dB)	Result (dBuV/m)	Remark	Limit (dBuV/m)		Margin (dB)	Table Deg.	Ant High (m)
						Peak	Ave			
2388.34	H	57.89	1.80	59.69	Peak	74	54	-14.31	120	1.00
2389.82	H	47.23	1.80	49.03	Ave	74	54	-4.97	120	1.00
2389.56	V	67.27	2.43	69.70	Peak	74	54	-4.60	202	1.00
2389.82	V	49.50	2.43	51.93	Ave	74	54	-2.07	202	1.00
Channel 11						Fundamental Frequency: 2462 MHz				
Frequency (MHz)	Ant-Pol H/V	Meter Reading (dBuV)	Corrected Factor (dB)	Result (dBuV/m)	Remark	Limit (dBuV/m)		Margin (dB)	Table Deg.	Ant High (m)
						Peak	Ave			
2483.85	H	59.81	0.49	60.30	Peak	74	54	-13.70	120	1.00
2483.66	H	47.46	0.49	47.95	Ave	74	54	-6.05	120	1.00
2483.74	V	71.61	-2.16	69.45	Peak	74	54	-4.55	202	1.00
2483.57	V	53.19	-2.15	51.04	Ave	74	54	-2.96	202	1.00

Modulation Standard: IEEE 802.11n HT40 (270Mbps)

Channel 3						Fundamental Frequency: 2422 MHz				
Frequency (MHz)	Ant-Pol H/V	Meter Reading (dBuV)	Corrected Factor (dB)	Result (dBuV/m)	Remark	Limit (dBuV/m)		Margin (dB)	Table Deg.	Ant High (m)
						Peak	Ave			
2385.28	H	58.61	1.80	60.41	Peak	74	54	-13.59	120	1.00
2389.56	H	47.35	1.79	49.14	Ave	74	54	-4.86	120	1.00
2388.03	V	68.78	2.46	71.24	Peak	74	54	-2.76	202	1.00
2388.80	V	48.94	2.44	51.38	Ave	74	54	-2.62	202	1.00
Channel 9						Fundamental Frequency: 2452 MHz				
Frequency (MHz)	Ant-Pol H/V	Meter Reading (dBuV)	Corrected Factor (dB)	Result (dBuV/m)	Remark	Limit (dBuV/m)		Margin (dB)	Table Deg.	Ant High (m)
						Peak	Ave			
2483.58	H	59.85	0.50	60.35	Peak	74	54	-13.65	120	1.00
2483.57	H	47.78	0.50	48.28	Ave	74	54	-5.72	120	1.00
2484.12	V	72.73	-2.18	70.55	Peak	74	54	-3.45	202	1.00
2483.57	V	53.80	-2.15	51.65	Ave	74	54	-2.35	202	1.00

Notes:

1. Result = Meter Reading + Factor
2. Factor = Antenna Factor + Cable Loss – Amplifier
3. The resolution bandwidth of test receiver/spectrum analyzer is 1MHz and video bandwidth is 3 MHz (detector peak mode) for Peak detection at frequency above 1GHz.
4. The resolution bandwidth of test receiver/spectrum analyzer is 1MHz and video bandwidth is 3 MHz (detector sample mode) for Average detection at frequency above 1GHz.



10. Restricted Bands of Operation

Only spurious emissions are permitted in any of the frequency bands listed below:

MHz	MHz	MHz	GHz
0.09000 – 0.11000	16.42000 – 16.42300	399.9 – 410.0	4.500 – 5.250
0.49500 – 0.505**	16.69475 – 16.69525	608.0 – 614.0	5.350 – 5.460
2.17350 – 2.19050	16.80425 – 16.80475	960.0 – 1240.0	7.250 – 7.750
4.12500 – 4.12800	25.50000 – 25.67000	1300.0 – 1427.0	8.025 – 8.500
4.17725 – 4.17775	37.50000 – 38.25000	1435.0 – 1626.5	9.000 – 9.200
4.20725 – 4.20775	73.00000 – 74.60000	1645.5 – 1646.5	9.300 – 9.500
6.21500 – 6.21800	74.80000 – 75.20000	1660.0 – 1710.0	10.600 – 12.700
6.26775 – 6.26825	108.00000 – 121.94000	1718.8 – 1722.2	13.250 – 13.400
6.31175 – 6.31225	123.00000 – 138.00000	2200.0 – 2300.0	14.470 – 14.500
8.29100 – 8.29400	149.90000 – 150.05000	2310.0 – 2390.0	15.350 – 16.200
8.36200 – 8.36600	156.52475 – 156.52525	2483.5 – 2500.0	17.700 – 21.400
8.37625 – 8.38675	156.70000 – 156.90000	2655.0 – 2900.0	22.010 – 23.120
8.41425 – 8.41475	162.01250 – 167.17000	3260.0 – 3267.0	23.600 – 24.000
12.29000 – 12.29300	167.72000 – 173.20000	3332.0 – 3339.0	31.200 – 31.800
12.51975 – 12.52025	240.00000 – 285.00000	3345.8 – 3358.0	36.430 – 36.500
12.57675 – 12.57725	322.00000 – 335.40000	3600.0 – 4400.0	Above 38.6
13.36000 – 13.41000			

** : Until February 1, 1999, this restricted band shall be 0.490-0.510 MHz

10.1 Labeling Requirement

The device shall bear the following statement in a conspicuous location on the device:

This device complies with part 15 of the FCC Rules. Operation is subject to the following two conditions: (1) This device may not cause harmful interference, and (2) this device must accept any interference received, including interference that may cause undesired operation.