



# SAR TEST REPORT

**Report No.:** 20231017G14173X-W2

**Product Name:** Mobile Data terminal  
DT50/DT50A/DT50B/DT50C/DT50D/DT50E/DT50F/DT50G/DT50H/DT50K

**Model Name:** /DT50M/ DT50MT/DT50P/DT50Q/DT50R/DT50S/DT50T/DT50U/DT50W/  
DT50Z/DT50X/DT5X(X: 1~9)/HS600/HB660/DT50 Pro

**Trade Name:** UROVO

**Brand Name:** UROVO

**FCC ID:** SWSDT50S

**Applicant:** UROVO TECHNOLOGY CO., LTD.  
**Address:** 36F,High-Tech Zone Union Tower,No.63,Xuefu Road, Nanshan District,  
Shenzhen, Guangdong, China

**Test Date:** 2023/11/11~2023/11/28

**Issued by:** CCIC Southern Testing Co., Ltd.

**Lab Location:** Electronic Testing Building, No. 43 Shahe Road Xili Street, Nanshan District,  
Shenzhen, Guangdong 518055, China

**Tel:** 86 755 26627338      **Fax:** 86 755 26627238

**Mail:** manager@ccic-set.com Website <http://www.ccic-set.com>

This test report consists of 76 pages in total. It may be duplicated completely for legal use with the approval of the applicant. It should not be reproduced except in full, without the written approval of our laboratory. The client should not use it to claim product endorsement by CCIC-SET. The test results in the report only apply to the tested sample. The test report shall be invalid without all the signatures of testing engineers, reviewer and approver. Any objections must be raised to CCIC-SET within 15 days since the date when the report is received. It will not be taken into consideration beyond this limit.



## Test Report

**Applicant:** UROVO TECHNOLOGY CO., LTD.

**Applicant Address:** 36F,High-Tech Zone Union Tower,No.63,Xuefu Road, Nanshan District, Shenzhen, Guangdong, China

**Manufacturer:** UROVO TECHNOLOGY CO., LTD.

**Manufacturer Address:** 36F,High-Tech Zone Union Tower,No.63,Xuefu Road, Nanshan District, Shenzhen, Guangdong, China

**47CFR §2.1093-** Radiofrequency Radiation Exposure Evaluation: Portable Devices;

**Test Standards:** **ANSI C95.1–1992:** Safety Levels with Respect to Human Exposure to Radio Frequency Electromagnetic Fields, 3 kHz – 300 GHz.( IEEE Std C95.1-1991)

**IEEE 1528–2013:** IEEE Recommended Practice for Determining the Peak Spatial-Average Specific Absorption Rate (SAR) in the Human Head from Wireless Communications Devices: Measurement Techniques

**Test Result:** Pass

**Tested by:** Carl Wei 2023-11-30

Carl Wei, Test Engineer

**Reviewed by:** Chris You 2023-11-30

Chris You, Senior Engineer

**Approved by:** Yang Fan 2023-11-30

Yang Fan, Manager



## Contents

Test Report .....	2
<b>1. Administrative Data.....</b>	<b>4</b>
<b>2. Equipment Under Test (EUT).....</b>	<b>5</b>
<b>3. SAR Summary.....</b>	<b>7</b>
<b>4. Specific Absorption Rate (SAR).....</b>	<b>10</b>
<b>5. Tissue check and recommend Dielectric Parameters .....</b>	<b>14</b>
<b>6. SAR measurement procedure .....</b>	<b>19</b>
<b>7. Conducted RF Output Power .....</b>	<b>20</b>
<b>8. Antenna Location:.....</b>	<b>44</b>
<b>9. Scaling Factor calculation .....</b>	<b>46</b>
<b>10. Test Results .....</b>	<b>49</b>
<b>11. Simultaneous Transmissions Analysis .....</b>	<b>67</b>
<b>12. Measurement Uncertainty.....</b>	<b>71</b>
<b>13. System Check Uncertainty .....</b>	<b>73</b>
<b>14. Equipment List.....</b>	<b>75</b>
ANNEX A: Appendix A: SAR System performance Check Plots.....	76
ANNEX B: Appendix B: SAR Measurement results Plots.....	76
ANNEX C: Appendix C: Calibration reports .....	76
ANNEX D: Appendix D: SAR Test Setup.....	76



# 1. Administrative Data

## 1.1 Testing Laboratory

<b>Test Site:</b>	CCIC Southern Testing Co., Ltd.
<b>Address:</b>	Electronic Testing Building, No. 43 Shahe Road Xili Street, Nanshan District, Shenzhen, Guangdong 518055, China
<b>A2LA Lab Code:</b>	CCIC-SET is a third party testing organization accredited by A2LA according to ISO/IEC 17025:2017. The accreditation certificate number is 5721.01
<b>FCC Registration:</b>	CCIC Southern Testing Co., Ltd. EMC Laboratory has been registered and fully described in a report filed with the FCC (Federal Communications Commission). The acceptance letter from the FCC is maintained in our files. Designation Number: CN1283, valid time is until June.30, 2025.
<b>ISED Registration:</b>	CCIC Southern Testing Co., Ltd. EMC Laboratory has been registered by Certification and Engineering Bureau of Industry Canada for the performance of radiated measurements with Registration No. 11185A-1 on Aug. 04, 2016, valid time is until June.30, 2025.
<b>Test Environment Condition:</b>	Temperature ( °C): 18 °C ~25 °C Relative Humidity (%): 35%~75% RH Atmospheric Pressure (kPa): 86KPa-106KPa



## 2. Equipment Under Test (EUT)

### Identification of the Equipment under Test

Device type :	portable device	
Exposure category:	uncontrolled environment / general population	
Product Name:	Mobile Data terminal	
Brand Name:	UROVO	
Model Name:	DT50/DT50A/DT50B/DT50C/DT50D/DT50E/DT50F/DT50G/DT50H/DT50K/DT50M/DT50MT/DT50P/DT50Q/DT50R/DT50S/DT50T/DT50U/DT50W/DT50Z/DT50X/DT5X(X: 1~9)/HS600/HB660/DT50 Pro	
Operating Band(s):	GSM850/1900, WCDMA Band II/IV/V, LTE Band 2,4,5,7,12,13,17,38,41, WIFI2.4G, WIFI5G (Band 1,2,3,4) ,BT	
Test Band(s):	GSM850/1900, WCDMA Band II/IV/V, LTE Band 2,4,5,7,12,13,17,38,41, WIFI2.4G, WIFI5G (Band 1,2,3,4) ,BT	
Test modulation:	GSM(GMSK,8PSK),UMTS(QPSK),LTE(QPSK/16QAM/64QAM), WI-FI 2.4G(DSSS, OFDM), WI-FI 5G(OFDM), BT( GFSK/ $\pi$ /4-DQPSK/8-DPSK)	
IMEI:	864430010001091/864430010001092	
Device Class:	B, GPRS:12, EDGE:12	
Tested frequency range(s)	transmitter frequency range	receiver frequency range
GSM 850:	824-849 MHz	869-894 MHz
GSM 1900:	1850-1910 MHz	1930-1990 MHz
WCDMA Band V:	824-849 MHz	869-894 MHz
WCDMA Band IV:	1710-1755 MHz	2110-2155 MHz
WCDMA Band II:	1850-1910 MHz	1930-1990 MHz
LTE Band 2:	1850-1910 MHz	1930-1990 MHz
LTE Band 4:	1710-1755 MHz	2110-2155 MHz
LTE Band 5:	824-849 MHz	869-894 MHz
LTE Band 7:	2500-2570 MHz	2620-2690 MHz
LTE Band 12:	698-716 MHz	728-746 MHz
LTE Band 13:	777-787 MHz	746-756 MHz
LTE Band 17:	704-716 MHz	734-746 MHz
LTE Band 38:	2570-2620 MHz	
LTE Band 41:	2496-2690 MHz	
Wi-Fi:	2412-2462 MHz	
	5150-5250 MHz	
	5250-5350 MHz	
	5470-5725 MHz	
	5725-5850 MHz	
Bluetooth:	2402-2480 MHz	
Hardware version :	QDC510	
Software version :	SQ53S_WE_DS_D_231028_01	



Antenna type :	Internal antenna
Hotspot :	2.4GWLAN support Hotspot mode
Battery options :	Model No.: HBLDT50 Capacitance: 4300mAh Rated Voltage: 3.85V Charge Limit: 4.4V Manufacturer: Zhongshan Tianmao Battery Co., Ltd
MAX. SAR Value:	Head: 0.381 W/Kg( Limit:1.6W/Kg, 0mm distance ) Body-worn: 1.007 W/Kg(Limit:1.6W/Kg, 10mm distance) Hotspot: 1.007 W/Kg(Limit:1.6W/Kg, 10mm distance)

**Note:**

1. The above EUT's information was declared by manufacturer. Please refer to the specifications or user's manual for more detailed description.
2. DT50A,DT50B,DT50C,DT50D,DT50E,DT50F,DT50G,DT50H,DT50K,DT50M,DT50MT,DT50P,DT50Q,DT50R,DT50S,DT50T,DT50U,DT50W,DT50Z,DT50X,DT5X(X:1~9),HS600,HB660,DT50 Pro compared with DT50, only have different model name. All of the model's circuit theory, electrical design and Critical Components are the same.



### 3. SAR Summary

#### Highest Standalone SAR Summary

Exposure Position	Frequency Band	Scaled 1g-SAR(W/kg)	Highest Scaled 1g-SAR(W/kg)
Head (0mm Gap)	GSM 850 ANT 4	0.156	0.381
	GSM 1900 ANT 4	0.117	
	WCDMA 850 ANT 4	0.120	
	WCDMA 1900 ANT 4	0.162	
	LTE Band 2 ANT 4	0.156	
	LTE Band 4 ANT 4	0.208	
	LTE Band 5 ANT 4	0.113	
	LTE Band 7 ANT 4	0.077	
	LTE Band 12 ANT 4	0.145	
	LTE Band 13 ANT 4	0.107	
	LTE Band 17 ANT 4	0.138	
	LTE Band 38 ANT 4	0.047	
	LTE Band 41 ANT 3	0.060	
	WIFI 2.4G ANT 2	0.189	
	WIFI U-NII 1 ANT 2	0.330	
	WIFI U-NII 2a ANT 2	0.362	
	WIFI U-NII 2c ANT 2	0.381	
	WIFI U-NII 3 ANT 2	0.350	
	BT ANT 2	0.061	



Exposure Position	Frequency Band	Scaled 1g-SAR(W/kg)	Highest Scaled 1g-SAR(W/kg)
Body-worn (10mm Gap)	GSM 850 ANT 4	0.242	1.007
	GSM 1900 ANT 4	0.735	
	WCDMA 850 ANT 4	0.215	
	WCDMA 1900 ANT 4	0.708	
	LTE Band 2 ANT 4	0.727	
	LTE Band 4 ANT 4	0.690	
	LTE Band 5 ANT 4	0.225	
	LTE Band 7 ANT 4	1.007	
	LTE Band 12 ANT 4	0.339	
	LTE Band 13 ANT 4	0.266	
	LTE Band 17 ANT 4	0.324	
	LTE Band 38 ANT 4	0.502	
	LTE Band 41 ANT 3	0.548	
	WIFI 2.4G ANT 2	0.372	
	WIFI U-NII 1 ANT 2	0.473	
	WIFI U-NII 2a ANT 2	0.507	
	WIFI U-NII 2c ANT 2	0.468	
	WIFI U-NII 3 ANT 2	0.430	
	BT ANT 2	0.101	





Exposure Position	Frequency Band	Scaled 1g-SAR(W/kg)	Highest Scaled 1g-SAR(W/kg)
Hotspot (10mm Gap)	GSM 850 ANT 4	0.242	1.007
	GSM 1900 ANT 4	0.735	
	WCDMA 850 ANT 4	0.215	
	WCDMA 1900 ANT 4	0.708	
	LTE Band 2 ANT 4	0.752	
	LTE Band 4 ANT 4	0.720	
	LTE Band 5 ANT 4	0.225	
	LTE Band 7 ANT 4	1.007	
	LTE Band 12 ANT 4	0.339	
	LTE Band 13 ANT 4	0.266	
	LTE Band 17 ANT 4	0.324	
	LTE Band 38 ANT 4	0.502	
	LTE Band 41 ANT 3	0.548	
	WIFI 2.4G ANT 2	0.372	

### Highest Simultaneous SAR Summary

Exposure Position	Frequency Band	Highest Simultaneous 1g-SAR(W/kg)
Body (10mmGap)	WWAN(LTE Band 7)&WIFI 5G	1.514

## 4. Specific Absorption Rate (SAR)

### 4.1 Introduction

SAR is related to the rate at which energy is absorbed per unit mass in an object exposed to a radio field. The SAR distribution in a biological body is complicated and is usually carried out by experimental techniques or numerical modeling. The standard recommends limits for two tiers of groups, occupational/controlled and general population/uncontrolled, based on a person's awareness and ability to exercise control over his or her exposure. In general, occupational/controlled exposure limits are higher than the limits for general population/uncontrolled.

The SAR definition is the time derivative (rate) of the incremental energy (dW) absorbed by (dissipated in) an incremental mass (dm) contained in a volume element (dv) of a given density ( $\rho$ ). The equation description is as below:

$$\text{SAR} = \frac{d}{dt} \left( \frac{dW}{dm} \right) = \frac{d}{dt} \left( \frac{dW}{\rho dv} \right)$$

SAR is expressed in units of Watts per kilogram (W/kg)

SAR measurement can be either related to the temperature elevation in tissue by

$$\text{SAR} = C \frac{\delta T}{\delta t}$$

where C is the specific heat capacity,  $\delta T$  is the temperature rise and  $\delta t$  the exposure duration, or related to the electrical field in the tissue by

$$\text{SAR} = \frac{\sigma |E|^2}{\rho}$$

where  $\sigma$  is the conductivity of the tissue,  $\rho$  is the mass density of the tissue and E is the rms electrical field strength.

However for evaluating SAR of low power transmitter, electrical field measurement is typically applied.



## 4.2 Applicable Standards and Limits

### 4.2.1 Applicable Standards

47CFR §2.1093	Radiofrequency Radiation Exposure Evaluation: Portable Devices
ANSI C95.1-1992	Safety Levels with Respect to Human Exposure to Radio Frequency Electromagnetic Fields, 3 kHz – 300 GHz.( IEEE Std C95.1-1991)
IEEE 1528-2013	IEEE Recommended Practice for Determining the Peak Spatial-Average Specific Absorption Rate (SAR) in the Human Head from Wireless Communications Devices: Measurement Techniques
KDB 248227 D01	v02r02 802.11 Wi-Fi SAR
KDB 447498 D01	v06 General RF Exposure Guidance
KDB 616217 D04	v01r02 SAR for laptop and tablets
KDB 648474 D04	v01r03 Handset SAR
KDB 865664 D01	v01r04 SAR Measurement 100MHz to 6GHz
KDB 865664 D02	v01r02 SAR Exposure Reporting
KDB 941225 D01	v03r01 3G SAR Procedures
KDB 941225 D05	v02r05 SAR for LTE Devices
KDB 941225 D05A	v01r02 LTE Rel.10 KDB Inquiry Sheet
KDB 941225 D06	v02r01 Hotspot Mode

### 4.2.2 RF exposure Limits

<b>Human Exposure</b>	<b>Uncontrolled Environment General Population</b>
<b>Spatial Peak SAR*</b> (Brain/Body)	1.60 mW/g
<b>Spatial Average SAR**</b> (Whole Body)	0.08 mW/g
<b>Spatial Peak SAR***</b> (Limbs)	4.00 mW/g

The limit applied in this test report is shown in bold letters.

Notes:

\* The Spatial Peak value of the SAR averaged over any 1 grams of tissue (defined as a tissue volume in the shape of a cube) and over the appropriate averaging time

\*\* The Spatial Average value of the SAR averaged over the whole body.

\*\*\* The Spatial Peak value of the SAR averaged over any 10 grams of tissue (defined as a tissue volume in the shape of a cube) and over the appropriate averaging time.

### 4.3 Phantoms

The phantom used for all tests i.e. for both system checks and device testing, was the twin-headed "SAM Phantom", manufactured by SATIMO. The SAM twin phantom is a fiberglass shell phantom with 2mm shell thickness (except the ear region, where shell thickness increases to 6mm).

System checking was performed using the flat section, whilst Head SAR tests used the left and right head profile sections. Body SAR testing also used the flat section between the head profiles.



SAM Twin Phantom

### 4.4 Device Holder

The device was placed in the device holder (illustrated below) that is supplied by SATIMO as an integral part of the COMOSAR test system.

The device holder is designed to cope with the different positions given in the standard. It has two scales for device rotation (with respect to the body axis) and device inclination (with respect to the line between the ear reference points). The rotation centers for both scales is the ear reference point (ERP). Thus the device needs no repositioning when changing the angles.



Device holder

## 4.5 Probe Specification



Construction	Symmetrical design with triangular core Interleaved sensors Built-in shielding against static charges PEEK enclosure material (resistant to organic solvents, e.g., DGBE)
Calibration	ISO/IEC 17025 calibration service available.
Frequency	700 MHz to 3 GHz; Linearity: $\pm 0.5$ dB (700 MHz to 3 GHz)
Directivity	$\pm 0.25$ dB in HSL (rotation around probe axis) $\pm 0.5$ dB in tissue material (rotation normal to probe axis)
Dynamic Range	1.5 $\mu$ W/g to 100 mW/g; Linearity: $\pm 0.5$ dB
Dimensions	Overall length: 330 mm (Tip: 20 mm) Tip diameter: 5 mm Distance from probe tip to dipole centers: <2.7 mm
Application	General dosimetry up to 3 GHz Dosimetry in strong gradient fields Compliance tests of mobile phones
Compatibility	COMOSAR

### Isotropic E-Field Probe

The isotropic E-Field probe has been fully calibrated and assessed for isotropicity, and boundary effect within a controlled environment. Depending on the frequency for which the probe is calibrated the method utilized for calibration will change.

The E-Field probe utilizes a triangular sensor arrangement as detailed in the diagram below:

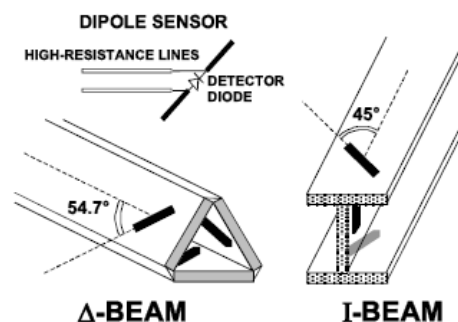



## 5. Tissue check and recommend Dielectric Parameters

### 5.1 Tissue Dielectric Parameters for Head and Body Phantoms

The head tissue dielectric parameters recommended by the IEEE SCC-34/SC-2 in P1528 have been incorporated in the following table. These head parameters are derived from planar layer models simulating the highest expected SAR for the dielectric properties and tissue thickness Power drifts in a human head. Other head and body tissue parameters that have not been specified in P1528 are derived from the tissue dielectric parameters computed from the 4-Cole-Cole equations described in Reference [12] and extrapolated according to the head parameters specified in P1528.

Table 1: Recommended Dielectric Performance of Tissue

Ingredients (% by weight )	Frequency (MHz)											
	450		835		915		1900		2450		2600	
Tissue Type	Head	Body	Head	Body	Head	Body	Head	Body	Head	Body	Head	Body
Water	38.56	51.16	41.46	52.4	41.05	56.0	54.9	40.4	62.7	73.2	55.24	64.49
Salt (NaCl)	3.95	1.49	1.45	1.4	1.35	0.76	0.18	0.5	0.5	0.04	0.5	0.024
Sugar	56.32	46.78	56.0	45.0	56.5	41.76	0.0	58.0	0.0	0.0	0.0	0.0
HEC	0.98	0.52	1.0	1.0	1.0	1.21	0.0	1.0	0.0	0.0	0.0	0.0
Bactericide	0.19	0.05	0.1	0.1	0.1	0.27	0.0	0.1	0.0	0.0	0.0	0.0
Triton x-100	0.0	0.0	0.0	0.0	0.0	0.0	0.0	0.0	36.8	0.0	44.45	32.25
DGBE	0.0	0.0	0.0	0.0	0.0	0.0	44.92	0.0	0.0	26.7	0.0	26.7
Dielectric Constant	43.42	58.0	42.54	56.1	42.0	56.8	39.9	54.0	39.2	52.5	39.0	52.5
Conductivity (s/m)	0.85	0.83	0.91	0.95	1.0	1.07	1.42	1.45	1.80	1.78	1.96	2.16

MSL/HSL750 (Body and Head liquid for 650 – 850 MHz)

Item	Head Tissue Simulation Liquid HSL750 Muscle(body)Tissue Simulation Liquid MSL750			
H2O	Water, 35 – 58%			
Sucrose	Sugar, white, refined, 40-60%			
NaCl	Sodium Chloride, 0-6%			
Hydroxyethyl-cellulose	Medium Viscosity (CAS# 9004-62-0), <0.3%			
Preventol-D7	Preservative: aqueous preparation, (CAS# 55965-84-9), containing 5-chloro-2-methyl-3(2H)-isothiazolone and 2-methyl-3(2H)-isothiazolone, 0.1-0.7%			
Frequency (MHz)	Head $\epsilon_r$	Head $\sigma$ (S/m)	Body $\epsilon_r$	Body $\sigma$ (S/m)
750	41.9	0.89	55.2	0.97

Note: The liquid of 700MHz&2600MHz typical liquid composition is provided by SATIMO.



Frequency:5200/5400/5600/5800MHz	
Ingredients	(% by weight)
Water	78
Mineral oil	11
Emulsifiers	9
Additives and Salt	2

Table 2 Recommended Tissue Dielectric Parameters

Frequency (MHz)	Head Tissue		Body Tissue	
	$\epsilon_r$	$\sigma$ (S/m)	$\epsilon_r$	$\sigma$ (S/m)
150	52.3	0.76	61.9	0.80
300	45.3	0.87	58.2	0.92
450	43.5	0.87	56.7	0.94
835	41.5	0.90	55.2	0.97
900	41.5	0.97	55.0	1.05
915	41.5	0.98	55.0	1.06
1450	40.5	1.20	54.0	1.30
1610	40.3	1.29	53.8	1.40
1800-2000	40.0	1.40	53.3	1.52
2450	39.2	1.80	52.7	1.95
3000	38.5	2.40	52.0	2.73
5800	35.3	5.27	48.2	6.00



5.2 Simulate liquid

Liquid check results:

Table 3: Dielectric Performance of Tissue Simulating Liquid

/	Frequency	Permittivity $\epsilon$	Conductivity $\sigma$ (S/m)	Liquid Temp. (°C)	Test Date
Target value	750MHz	41.9±5% (39.805~43.995)	0.89±5% (0.8455~0.9345)	22.2	2023/11/28
Validation value		42.63	0.88		
Target value	835MHz	41.5±5% (39.425~43.575)	0.90±5% (0.855~0.945)	22.5	2023/11/11
Validation value		41.67	0.91		
Target value	1800MHz	40.0±5% (38.0~42.0)	1.40±5% (1.33~1.47)	22.1	2023/11/13
Validation value		40.59	1.39		
Target value	1900MHz	40.0±5% (38.0~42.0)	1.40±5% (1.33~1.47)	22.9	2023/11/21
Validation value		39.69	1.41		
Target value	2450MHz	39.2±5% (37.24~41.16)	1.80±5% (1.71~1.89)	22.6	2023/11/22
Validation value		39.86	1.81		
Target value	2600MHz	39.0±5% (37.05~40.95)	1.96±5% (1.862~2.058)	22.2	2023/11/25
Validation value		38.53	1.97		
Target value	5200MHz	36.0±5% (34.20~37.80)	4.66±5% (4.427~4.893)	22.1	2023/11/15
Validation value		36.24	4.63		
Target value	5400MHz	35.8±5% (34.01~37.59)	4.86±5% (4.617~5.103)	22.1	2023/11/15
Validation value		36.01	4.88		
Target value	5600MHz	35.5±5% (33.725~37.275)	5.07±5% (4.8165~5.3235)	22.4	2023/11/17
Validation value		35.68	5.01		
Target value	5800MHz	35.3±5% (33.535~37.065)	5.27±5% (5.0065~5.5335)	22.4	2023/11/17
Validation value		35.27	5.25		



## SAR System validation

Prior to the assessment, the system validation kit was used to test whether the system was operating within its specifications of  $\pm 10\%$ . The validation results are tabulated below. And also the corresponding SAR plot is attached as well in the SAR plots files.

The following procedure, recommended for performing validation tests using box phantoms is based on the procedures described in the IEEE standard P1528. Setup according to the setup diagram below:

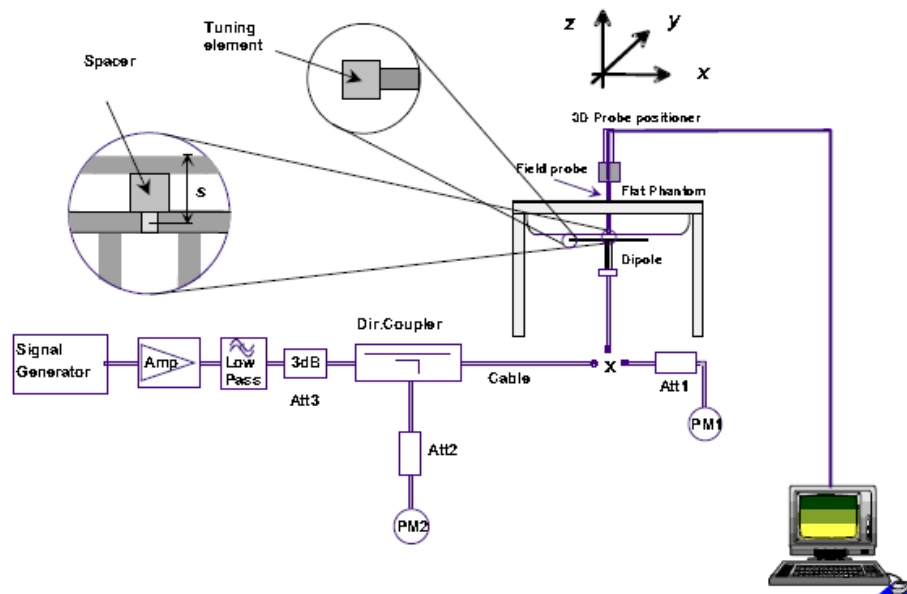

With the SG and Amp and with directional coupler in place, set up the source signal at the relevant frequency and use a power meter to measure the power at the end of the SMA cable that you intend to connect to the balanced dipole. Adjust the SG to make this, say, 0.01W (10 dBm). If this level is too high to read directly with the power meter sensor, insert a calibrated attenuator (e.g. 10 or 20 dB) and make a suitable correction to the power meter reading.

Note 1: In this method, the directional coupler is used for monitoring rather than setting the exact feed power level.

If, however, the directional coupler is used for power measurement, you should check the frequency range and power rating of the coupler and measure the coupling factor (referred to output) at the test frequency using a VNA.

Note 2: Remember that the use of a 3dB attenuator (as shown in Figure 8.1 of P1528) means that you need an RF amplifier of 2 times greater power for the same feed power. The other issue is the cable length. You might get up to 1dB of loss per meter of cable, so the cable length after the coupler needs to be quite short.

Note 3: For the validation testing done using CW signals, most power meters are suitable. However, if you are measuring the output of a modulated signal from either a signal generator or a handset, you must ensure that the power meter correctly reads the modulated signals.

The measured 1-gram averaged SAR values of the device against the phantom are provided in Tables 5 and Table 6. The body phantom were full of the body tissue simulating liquid. The EUT was supplied with full-charged battery for each measurement.

The distance between the back of the EUT and the bottom of the flat phantom is 10 mm (taking into account of the IEEE 1528 and the place of the antenna).

Table 4: system validation (1g)  
System Check Results

Frequency	Duty cycle	Target value (1-g) (W/Kg)	10mW Test value (1-g) (W/Kg)	Test SAR Normalized to 1W(w/Kg)	Test Date
750MHz	1:1	8.65 W/kg±10% (7.785~9.515)	0.0860	8.60	2023/11/28
835MHz	1:1	9.93 W/kg±10% (8.937~10.923)	0.0941	9.41	2023/11/11
1800MHz	1:1	37.81 W/kg±10% (34.029~41.591)	0.3835	38.35	2023/11/13
1900MHz	1:1	41.50 W/kg±10% (37.350~45.650)	0.3825	38.25	2023/11/21
2450MHz	1:1	51.74 W/kg±10% (46.566~56.914)	0.5236	52.36	2023/11/22
2600MHz	1:1	57.13 W/kg±10% (51.417~62.843)	0.5382	53.82	2023/11/25
5200MHz	1:1	152.95 W/kg±10% (137.655~168.245)	1.4905	149.05	2023/11/15
5400MHz	1:1	159.94 W/kg±10% (143.946~175.934)	1.5798	157.98	2023/11/15
5600MHz	1:1	166.59 W/kg±10% (149.931~183.249)	1.6015	160.15	2023/11/15
5800MHz	1:1	174.67 W/kg±10% (157.203~192.137)	1.7300	173.00	2023/11/15

**Note:**

1. Target value was referring to the measured value in the calibration certificate of reference dipole.
2. All SAR values are normalized to 1W forward power.

## 6. SAR measurement procedure

The SAR test against the head phantom was carried out as follow:

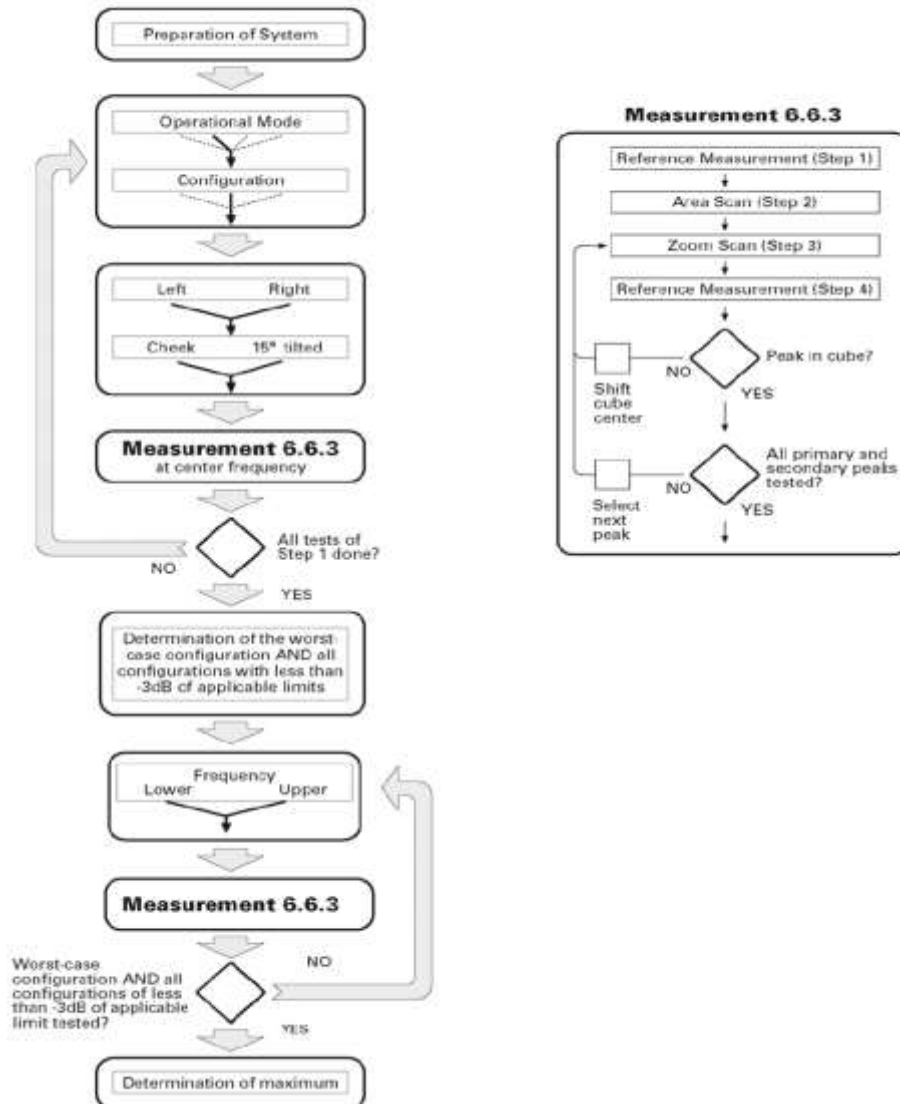

Establish a call with the maximum output power with a base station simulator, the connection between the EUT and the base station simulator is established via air interface.

After an area scan has been done at a fixed distance of 2mm from the surface of the phantom on the source side, a 3D scan is set up around the location of the maximum spot SAR. First, a point within the scan area is visited by the probe and a SAR reading taken at the start of testing. At the end of testing, the probe is returned to the same point and a second reading is taken. Comparison between these start and end readings enables the power drift during measurement to be assessed.

Above is the scanning procedure flow chart and table from the IEEE p1528 standard. This is the procedure for which all compliant testing should be carried out to ensure that all variations of the device position and transmission behavior are tested.



## 7. Conducted RF Output Power

### 7.1 GSM Conducted Power

GSM850 ANT 4		Burst-Averaged output Power (dBm)			Division Factors	Frame-Averaged output Power (dBm)		
		128CH	190CH	251CH		128CH	190CH	251CH
		824.2	836.6	848.8		824.2	836.6	848.8
GSM (CS)		32.67	32.97	32.80	-9.03	23.64	23.94	23.77
GPRS (GMSK)	1 Tx Slot	32.65	32.96	32.78	-9.03	23.62	23.93	23.75
	2 Tx Slots	30.99	31.35	31.53	-6.02	24.97	25.33	25.51
	3 Tx Slots	29.43	29.53	29.83	-4.26	25.17	25.27	25.57
	4 Tx Slots	28.08	28.47	<b>28.75</b>	-3.01	25.07	25.46	<b>25.74</b>
EDGE (8PSK)	1 Tx Slot	26.59	26.93	27.07	-9.03	17.56	17.90	18.04
	2 Tx Slots	25.81	26.12	26.32	-6.02	19.79	20.10	20.30
	3 Tx Slots	24.16	24.46	24.57	-4.26	19.90	20.20	20.31
	4 Tx Slots	22.88	23.15	23.32	-3.01	19.87	20.14	20.31
GSM1900 ANT 4		Burst-Averaged output Power (dBm)			Division Factors	Frame-Averaged output Power (dBm)		
		512CH	661CH	810CH		512CH	661CH	810CH
		1850.2	1880.0	1909.8		1850.2	1880.0	1909.8
GSM (CS)		30.04	30.20	29.96	-9.03	21.01	21.17	20.93
GPRS (GMSK)	1 Tx Slot	30.02	30.19	29.95	-9.03	20.99	21.16	20.92
	2 Tx Slots	28.67	28.86	28.63	-6.02	22.65	22.84	22.61
	3 Tx Slots	26.23	26.80	26.59	-4.26	21.97	22.54	22.33
	4 Tx Slots	25.69	<b>25.98</b>	25.78	-3.01	22.68	<b>22.97</b>	22.77
EDGE (8PSK)	1 Tx Slot	25.95	26.22	25.91	-9.03	16.92	17.19	16.88
	2 Tx Slots	25.24	25.51	25.22	-6.02	19.22	19.49	19.20
	3 Tx Slots	23.45	23.73	23.41	-4.26	19.19	19.47	19.15
	4 Tx Slots	22.22	22.52	22.23	-3.01	19.21	19.51	19.22

**Note:**

1. Per KDB 447498 D01 v06, the maximum output power channel is used for SAR testing and for further SAR test reduction.
2. For hotspot SAR, EUT was performed at GPRS Class 12 multi-slots (4Tx) mode.

Timeslot consignations

No. Of Slots	Slot 1	Slot 2	Slot 3	Slot 4
Slot Consignation	1Up4Down	2UpDown	3UpDown	4Up1Down
Duty Cycle	1:8	1:4	1:2.67	1:2
Crest Factor	-9.03dB	-6.02dB	-4.26dB	-3.01dB



## 7.2 WCDMA Conducted output Power

UMTS850 (Band V) ANT 4		Averaged output Power (dBm)		
		4132CH	4183CH	4233CH
		826.4	836.6	846.6
WCDMA	12.2kbps RMC	22.80	22.73	22.67
HSDPA	Subtest 1	21.65	21.59	21.71
	Subtest 2	20.89	20.72	20.88
	Subtest 3	21.97	22.04	21.86
	Subtest 4	21.56	21.47	21.43
HSUPA	Subtest 1	21.40	21.36	21.42
	Subtest 2	21.25	21.23	21.31
	Subtest 3	22.01	21.85	21.93
	Subtest 4	21.67	21.73	21.53
	Subtest 5	20.95	21.02	21.03
UMTS1900 (Band II) ANT 4		Averaged output Power (dBm)		
		9262CH	9400CH	9538cH
		1852.4	1880.0	1907.6
WCDMA	12.2kbps RMC	23.25	23.43	23.14
HSDPA	Subtest 1	22.13	21.92	22.09
	Subtest 2	22.27	22.07	22.22
	Subtest 3	21.52	21.71	21.66
	Subtest 4	21.84	21.95	21.81
HSUPA	Subtest 1	21.90	21.93	21.84
	Subtest 2	21.92	22.01	22.06
	Subtest 3	22.03	21.91	21.97
	Subtest 4	21.93	21.82	21.77
	Subtest 5	21.18	21.05	21.29

**Note:**

1. WCDMA SAR was tested under RMC 12.2kbps with HSPA Inactive per KDB Publication 941225 D01v03r01.HSPA SAR was not requires since the average output power of the HSPA subtests was not more than 0.25dB higher than the RMC level and SAR was less than 1.2W/kg.
2. It is expected by the manufacturer that MPR for some HSPA subtests may be up to 2dB more than specified by 3GPP, but also as low as 0dB according to the chipset implementation in this model

## 7.3 LTE Conducted peak output Power

### LTE Test Configurations

The CMW500 Wide Band Radio Communication Tester was used for LTE output power measurements and SAR testing. Closed loop power control was used so the UE transmits with maximum output power during SAR testing. SAR test were performed with the same number of RB and RB offsets transmitting on all frames.

#### 1) Spectrum Plots for RB configurations

A properly configured base station simulator was used for LTE output power measurements and SAR testing. Therefore, spectrum plots for RB configurations were not required to be included in this report.

#### 2) MPR

When MPR is implemented permanently within the UE, regardless of network requirements, only those RB configurations allowed by 3GPP for the channel bandwidth and modulation combinations may be tested with MPR active. Configurations with RB allocations less than the RB thresholds required by 3GPP must be tested without MPR.

The allowed Maximum Power Reduction(MPR) for the maximum output power due to higher order modulation and transmit bandwidth configuration (resource blocks) is specified in Table 6.2.3-1 of the 3GPP TS36.101:

**Table 6.2.3-1: Maximum Power Reduction (MPR) for Power Class 3**

Modulation	Channel bandwidth / Transmission bandwidth configuration [RB]						MPR (dB)
	1.4 MHz	3.0 MHz	5 MHz	10 MHz	15 MHz	20 MHz	
QPSK	> 5	> 4	> 8	> 12	> 16	> 18	≤ 1
16 QAM	≤ 5	≤ 4	≤ 8	≤ 12	≤ 16	≤ 18	≤ 1
16 QAM	> 5	> 4	> 8	> 12	> 16	> 18	≤ 2

#### 3) A-MPR LTE procedures for SAR testing

A-MPR(Additional MPR) has been disabled for all SAR tests by using Network Signaling Value of “NS\_01” on the base station simulator.

#### 4) LTE procedures for SAR testing

A) Largest channel bandwidth standalone SAR test

requirements i) QPSK with 1 RB allocation

Start with the largest channel bandwidth and measure SAR for QPSK with 1 RB allocation, using the RB offset and required test channel combination with the highest maximum output power for RB offsets at the upper edge, middle and lower edge of each required test channel. When the reported SAR is  $\leq 0.8$ W/kg, testing of the remaining RB offset configurations and required test channels is not required for 1RB allocation; otherwise, SAR is required for the remaining required test channels and only for the RB offset configuration with the highest output power for that channel. When the reported SAR of a required test channel is  $> 1.45$  W/kg, SAR is required for all three RB offset configurations for that required test channel.



1. LTE Band 2 Conducted Power Test Verdict:

LTE FDD Band 2 ANT 4				Conducted Power(dBm)			Tune up
Bandwidth	Modulation	RB size	RB offset	Channel/Frequency			
				18607/1850.7	18900/1880.0	19193/1909.3	
1.4MHz	QPSK	1	0	23.21	23.74	23.60	23.0±1.0
		1	3	23.53	23.73	23.57	
		1	5	23.40	23.57	23.66	
		3	0	22.52	22.47	22.54	22.0±1.0
		3	2	22.52	22.47	22.55	
		3	3	22.43	22.46	22.50	
		6	0	22.27	22.44	22.45	22.0±1.0
	16QAM	1	0	22.35	22.53	22.36	22.0±1.0
		1	3	22.62	22.21	22.44	
		1	5	22.48	22.61	22.47	
		3	0	21.56	21.42	21.29	21.0±1.0
		3	2	21.48	21.35	21.30	
		3	3	21.28	21.23	21.39	
		6	0	21.39	21.25	21.48	21.0±1.0
Bandwidth	Modulation	RB size	RB offset	Channel/Frequency			Tune up
				18615/1851.5	18900/1880.0	19185/1908.5	
3MHz	QPSK	1	0	23.33	23.51	23.36	23.0±1.0
		1	7	23.35	23.54	23.41	
		1	14	23.29	23.44	23.30	
		8	0	22.45	22.52	22.38	22.0±1.0
		8	4	22.34	22.53	22.42	
		8	7	22.40	22.52	22.38	
		15	0	22.36	22.53	22.48	22.0±1.0
	16QAM	1	0	22.47	22.61	22.51	22.0±1.0
		1	7	22.51	22.50	22.37	
		1	14	22.57	22.54	22.46	
		8	0	21.50	21.45	21.50	21.0±1.0
		8	4	21.50	21.43	21.50	
		8	7	21.46	21.37	21.68	
		15	0	21.30	21.26	21.32	21.0±1.0



LTE FDD Band 2 ANT 4				Conducted Power(dBm)			
Bandwidth	Modulation	RB size	RB offset	Channel/Frequency			Tune up
				18625/1852.5	18900/1880.0	19175/1907.5	
5MHz	QPSK	1	0	23.42	23.35	23.23	23.0±1.0
		1	13	23.35	23.36	23.09	
		1	24	23.45	23.41	23.00	
		12	0	22.34	22.50	22.34	22.0±1.0
		12	6	22.34	22.51	22.34	
		12	13	22.36	22.45	22.31	
		25	0	22.38	22.48	22.31	22.0±1.0
	16QAM	1	0	22.53	22.44	22.35	22.0±1.0
		1	13	22.45	22.30	22.21	
		1	24	22.42	22.36	22.32	
		12	0	21.26	21.36	21.23	21.0±1.0
		12	6	21.39	21.47	21.41	
		12	13	21.27	21.32	21.21	
		25	0	21.39	21.42	21.46	21.0±1.0
Bandwidth	Modulation	RB size	RB offset	Channel/Frequency			Tune up
				18650/1855	18900/1880.0	19150/1905	
10MHz	QPSK	1	0	23.53	23.38	23.34	23.0±1.0
		1	25	23.38	23.52	23.31	
		1	49	23.44	23.67	23.36	
		25	0	22.36	22.64	22.32	22.0±1.0
		25	13	22.37	22.63	22.33	
		25	25	22.42	22.61	22.33	
		50	0	22.38	22.59	22.36	22.0±1.0
	16QAM	1	0	22.32	22.49	22.62	22.0±1.0
		1	25	22.35	22.58	22.49	
		1	49	22.51	22.61	22.45	
		25	0	21.19	21.55	21.35	21.0±1.0
		25	13	21.45	21.60	21.43	
		25	25	21.44	21.58	21.35	
		50	0	21.17	21.45	21.20	21.0±1.0





LTE FDD Band 2 ANT 4				Conducted Power(dBm)			
Bandwidth	Modulation	RB size	RB offset	Channel/Frequency			Tune up
				18675/1857.5	18900/1880.0	19125/1902.5	
15MHz	QPSK	1	0	23.36	23.32	23.26	23.0±1.0
		1	38	23.32	23.54	23.32	
		1	74	23.53	23.71	23.27	
		36	0	22.59	22.69	22.62	22.0±1.0
		36	18	22.53	22.64	22.61	
		36	39	22.65	22.57	22.49	
		75	0	22.43	22.54	22.36	22.0±1.0
	16QAM	1	0	22.33	22.49	22.36	22.0±1.0
		1	38	22.27	22.43	22.49	
		1	74	22.38	22.45	22.43	
		36	0	21.33	21.55	21.42	21.0±1.0
		36	18	21.32	21.60	21.41	
		36	39	21.49	21.38	21.36	
		75	0	21.34	21.51	21.38	21.0±1.0
Bandwidth	Modulation	RB size	RB offset	Channel/Frequency			Tune up
				18700/1860.0	18900/1880.0	19100/1900.0	
20MHz	QPSK	1	0	23.35	23.33	23.10	23.0±1.0
		1	50	23.31	23.68	23.27	
		1	99	23.73	23.62	23.60	
		50	0	22.45	22.63	22.38	22.0±1.0
		50	25	22.46	22.58	22.37	
		50	50	22.54	22.50	22.38	
		100	0	22.51	22.49	22.45	22.0±1.0
	16QAM	1	0	22.53	22.38	22.55	22.0±1.0
		1	50	22.39	22.41	22.51	
		1	99	22.66	22.64	22.68	
		50	0	21.40	21.60	21.32	21.0±1.0
		50	25	21.40	21.63	21.31	
		50	50	21.38	21.45	21.52	
		100	0	21.25	21.32	21.23	21.0±1.0



2. LTE Band 4 Conducted Power Test Verdict:

LTE FDD Band 4 ANT 4				Conducted Power(dBm)			Tune up
Bandwidth	Modulation	RB size	RB offset	Channel/Frequency			
				19957/1710.7	20175/1732.5	20393/1754.3	
1.4MHz	QPSK	1	0	23.60	23.61	23.50	23.0±1.0
		1	3	23.62	23.76	23.55	
		1	5	23.45	23.74	23.54	
		3	0	22.52	22.69	22.32	22.0±1.0
		3	2	22.53	22.69	22.41	
		3	3	22.39	22.47	22.25	
		6	0	22.43	22.55	22.29	22.0±1.0
	16QAM	1	0	22.45	22.41	22.61	22.0±1.0
		1	3	22.39	22.53	22.42	
		1	5	22.58	22.52	22.57	
		3	0	21.33	21.49	21.36	21.0±1.0
		3	2	21.27	21.43	21.39	
		3	3	21.38	21.45	21.43	
		6	0	21.34	21.48	21.38	21.0±1.0
Bandwidth	Modulation	RB size	RB offset	Channel/Frequency			Tune up
3MHz	QPSK	1	0	23.43	23.31	23.50	23.0±1.0
		1	7	23.31	23.67	23.44	
		1	14	23.24	23.33	23.37	
		8	0	22.45	22.59	22.22	22.0±1.0
		8	4	22.46	22.60	22.20	
		8	7	22.42	22.54	22.36	
		15	0	22.30	22.64	22.29	22.0±1.0
	16QAM	1	0	22.57	22.37	22.39	22.0±1.0
		1	7	22.48	22.43	22.32	
		1	14	22.37	22.50	22.40	
		8	0	21.30	21.65	21.24	21.0±1.0
		8	4	21.39	21.66	21.26	
		8	7	21.24	21.60	21.32	
		15	0	21.23	21.46	21.21	21.0±1.0



LTE FDD Band 4 ANT 4				Conducted Power(dBm)			
Bandwidth	Modulation	RB size	RB offset	Channel/Frequency			Tune up
				19975/1712.5	20175/1732.5	20375/1752.5	
5MHz	QPSK	1	0	23.43	23.59	23.37	23.0±1.0
		1	13	23.57	23.65	23.48	
		1	24	23.41	23.50	23.39	
		12	0	22.39	22.64	22.31	22.0±1.0
		12	6	22.43	22.64	22.43	
		12	13	22.29	22.41	22.32	
	16QAM	25	0	22.26	22.49	22.35	22.0±1.0
		1	0	22.53	22.34	22.39	22.0±1.0
		1	13	22.35	22.53	22.20	
		1	24	22.40	22.40	22.28	
		12	0	21.39	21.52	21.28	21.0±1.0
		12	6	21.36	21.56	21.35	
		12	13	21.45	21.47	21.32	
		25	0	21.41	21.42	21.26	21.0±1.0
Bandwidth	Modulation	RB size	RB offset	Channel/Frequency			Tune up
10MHz	QPSK	1	0	23.41	23.38	23.49	23.0±1.0
		1	25	23.36	23.65	23.27	
		1	49	23.69	23.62	23.57	
		25	0	22.37	22.61	22.29	22.0±1.0
		25	13	22.33	22.54	22.29	
		25	25	22.47	22.33	22.35	
		50	0	22.39	22.53	22.42	22.0±1.0
	16QAM	1	0	22.36	22.42	22.49	22.0±1.0
		1	25	22.53	22.61	22.57	
		1	49	22.64	22.59	22.35	
		25	0	21.39	21.54	21.41	21.0±1.0
		25	13	21.41	21.66	21.51	
		25	25	21.49	21.47	21.48	
		50	0	21.36	21.40	21.38	21.0±1.0



LTE FDD Band 4 ANT 4				Conducted Power(dBm)			
Bandwidth	Modulation	RB size	RB offset	Channel/Frequency			Tune up
				20025/1717.5	20175/1732.5	20325/1747.5	
15MHz	QPSK	1	0	23.49	23.40	23.38	23.0±1.0
		1	38	23.39	23.61	23.26	
		1	74	23.42	23.44	23.38	
		36	0	22.40	22.55	22.38	22.0±1.0
		36	18	22.37	22.51	22.43	
		36	39	22.51	22.39	22.56	
		75	0	22.42	22.53	22.34	22.0±1.0
	16QAM	1	0	22.54	22.43	22.47	22.0±1.0
		1	38	22.43	22.66	22.44	
		1	74	22.36	22.51	22.35	
		36	0	21.49	21.45	21.33	21.0±1.0
		36	18	21.56	21.55	21.41	
		36	39	21.57	21.38	21.55	
		75	0	21.30	21.41	21.21	21.0±1.0
Bandwidth	Modulation	RB size	RB offset	Channel/Frequency			Tune up
20MHz	QPSK	1	0	23.58	23.42	23.35	23.0±1.0
		1	50	23.38	23.56	23.47	
		1	99	23.59	23.69	23.60	
		50	0	22.35	22.51	22.48	22.0±1.0
		50	25	22.46	22.54	22.39	
		50	50	22.55	22.49	22.42	
		100	0	22.47	22.54	22.35	22.0±1.0
	16QAM	1	0	22.66	22.44	22.34	22.0±1.0
		1	50	22.31	22.51	22.48	
		1	99	22.44	22.48	22.37	
		50	0	21.30	21.58	21.33	21.0±1.0
		50	25	21.30	21.59	21.44	
		50	50	21.51	21.27	21.27	
		100	0	21.32	21.47	21.43	21.0±1.0



3. LTE Band 5 Conducted Power Test Verdict:

LTE FDD Band 5 ANT 4				Conducted Power(dBm)			Tune up		
Bandwidth	Modulation	RB size	RB offset	Channel/Frequency					
				20407/824.7	20525/836.5	20643/848.3			
1.4MHz	QPSK	1	0	23.57	23.60	23.48	23.0±1.0		
		1	3	23.65	23.59	23.56			
		1	5	23.69	23.63	23.58			
		3	0	22.66	22.57	22.59	22.0±1.0		
		3	2	22.56	22.49	22.52			
		3	3	22.56	22.49	22.63			
	16QAM	16QAM	6	0	22.60	22.46	22.57	22.0±1.0	
			1	0	22.39	22.35	22.34	22.0±1.0	
			1	3	22.41	22.54	22.47		
			1	5	22.36	22.45	22.52		
			21.0±1.0	16QAM	3	0	21.32	21.38	21.62
					3	2	21.51	21.41	21.57
					3	3	21.41	21.53	21.59
					6	0	21.43	21.35	21.54
21.0±1.0	16QAM	6	0	21.43	21.35	21.54			
		6	0	21.43	21.35	21.54			
Bandwidth	Modulation	RB size	RB offset	Channel/Frequency			Tune up		
3MHz	QPSK	1	0	23.64	23.68	23.45	23.0±1.0		
		1	7	23.61	23.59	23.45			
		1	14	23.66	23.55	23.47			
		22.0±1.0	QPSK	8	0	22.77	22.62	22.54	
				8	4	22.78	22.72	22.55	
				8	7	22.77	22.68	22.64	
				15	0	22.85	22.66	22.44	
	22.0±1.0	16QAM	1	0	22.96	22.85	22.88		
			1	7	23.07	23.04	22.73		
			1	14	23.00	22.87	23.26		
			21.0±1.0	16QAM	8	0	21.54	21.82	21.42
					8	4	21.46	21.82	21.42
					8	7	22.01	21.79	21.51
			21.0±1.0	16QAM	15	0	21.74	21.64	21.32



LTE FDD Band 5 ANT 4				Conducted Power(dBm)			
Bandwidth	Modulation	RB size	RB offset	Channel/Frequency			Tune up
				20425/826.5	20525/836.5	20625/846.5	
5MHz	QPSK	1	0	23.52	23.48	23.49	23.0±1.0
		1	13	23.39	23.56	23.39	
		1	24	23.49	23.56	23.32	
		12	0	22.71	22.58	22.39	22.0±1.0
		12	6	22.66	22.59	22.40	
		12	13	22.67	22.59	22.53	
	25	0	22.69	22.60	22.46	22.0±1.0	
	16QAM	1	0	22.56	22.39	22.47	22.0±1.0
		1	13	22.55	22.52	22.56	
		1	24	22.64	22.63	22.49	
		12	0	21.60	21.56	21.32	21.0±1.0
		12	6	21.59	21.54	21.32	
		12	13	21.67	21.53	21.49	
		25	0	21.63	21.58	21.58	21.0±1.0
Bandwidth	Modulation	RB size	RB offset	Channel/Frequency			Tune up
10MHz	QPSK	1	0	23.60	23.42	23.38	23.0±1.0
		1	25	23.62	23.65	23.42	
		1	49	23.71	23.44	23.32	
		25	0	22.73	22.62	22.66	22.0±1.0
		25	13	22.74	22.62	22.66	
		25	25	22.69	22.64	22.49	
		50	0	22.66	22.68	22.55	22.0±1.0
	16QAM	1	0	22.46	22.55	22.61	22.0±1.0
		1	25	22.66	22.61	22.67	
		1	49	22.68	22.59	22.59	
		25	0	21.78	21.69	21.67	21.0±1.0
		25	13	21.78	21.67	21.72	
		25	25	21.73	21.71	21.54	
		50	0	21.53	21.61	21.49	21.0±1.0
Bandwidth	Modulation	RB size	RB offset	20450/829.0	20525/836.5	20600/844.0	Tune up



4. LTE Band 7 Conducted Power Test Verdict:

LTE FDD Band 7 ANT 4				Conducted Power(dBm)			Tune up
Bandwidth	Modulation	RB size	RB offset	Channel/Frequency			
				20775/2502.5	21100/2535.0	21425/2567.5	
5MHz	QPSK	1	0	22.69	23.33	23.32	23.0±1.0
		1	13	22.80	23.63	23.33	
		1	24	22.92	23.41	23.56	
		12	0	22.08	22.56	22.65	22.0±1.0
		12	6	22.06	22.46	22.76	
		12	13	22.11	22.55	22.68	
		25	0	22.15	22.55	22.69	22.0±1.0
	16QAM	1	0	22.53	22.75	23.29	22.5±1.0
		1	13	22.24	22.82	22.77	
		1	24	22.33	22.75	22.91	
		12	0	20.97	21.26	21.50	21.0±1.0
		12	6	21.06	21.31	21.52	
		12	13	21.11	21.41	21.49	
		25	0	20.97	21.57	21.80	21.0±1.0
Bandwidth	Modulation	RB size	RB offset	Channel/Frequency			Tune up
				20800/2505.0	21100/2535.0	21400/2565.0	
10MHz	QPSK	1	0	23.30	23.46	23.64	23.0±1.0
		1	25	23.18	23.61	23.59	
		1	49	23.14	23.71	23.45	
		25	0	22.16	22.64	22.70	22.0±1.0
		25	13	22.17	22.74	22.66	
		25	25	22.33	22.59	22.73	
		50	0	22.31	22.58	22.62	22.0±1.0
	16QAM	1	0	22.90	23.12	23.22	22.5±1.0
		1	25	22.62	23.00	23.17	
		1	49	22.63	23.02	23.16	
		25	0	21.09	21.61	21.40	21.0±1.0
		25	13	21.09	21.52	21.51	
		25	25	21.28	21.34	21.51	
		50	0	21.18	21.32	21.53	21.0±1.0



LTE FDD Band 7 ANT 4				Conducted Power(dBm)			
Bandwidth	Modulation	RB size	RB offset	Channel/Frequency			Tune up
				20825/2507.5	21100/2535.0	21375/2562.5	
15MHz	QPSK	1	0	23.23	23.40	23.57	23.0±1.0
		1	38	23.15	23.83	23.67	
		1	74	23.13	23.38	23.39	
		36	0	22.72	22.76	23.02	22.5±1.0
		36	18	22.72	22.76	23.01	
		36	39	22.84	22.35	22.78	
		75	0	22.32	22.48	22.59	22.0±1.0
	16QAM	1	0	22.89	22.53	23.18	22.5±1.0
		1	38	22.72	22.79	23.01	
		1	74	22.73	23.05	22.99	
		36	0	22.71	22.77	23.01	21.0±1.0
		36	18	22.71	22.70	23.00	
		36	39	22.86	22.35	22.79	
		75	0	21.25	21.51	21.41	21.0±1.0
Bandwidth	Modulation	RB size	RB offset	Channel/Frequency			Tune up
				20850/2510.0	21100/2535.0	21350/2560.0	
20MHz	QPSK	1	0	23.37	23.22	23.45	23.0±1.0
		1	50	22.92	23.61	23.39	
		1	99	23.36	23.76	23.43	
		50	0	22.34	22.60	22.62	22.0±1.0
		50	25	22.35	22.61	22.55	
		50	50	22.43	22.52	22.61	
		100	0	22.34	22.53	22.59	22.0±1.0
	16QAM	1	0	22.17	22.72	22.82	22.5±1.0
		1	50	22.42	22.85	22.59	
		1	99	22.58	22.70	22.65	
		50	0	21.34	21.51	21.56	21.0±1.0
		50	25	21.34	21.52	21.56	
		50	50	21.33	21.53	21.58	
		100	0	21.16	21.56	21.62	21.0±1.0





5. LTE Band 12 Conducted Power Test Verdict:

LTE FDD Band 12 ANT 4				Conducted Power(dBm)					
Bandwidth	Modulation	RB size	RB offset	Channel/Frequency			Tune up		
				23017/699.7	23095/707.5	23173/715.3			
1.4MHz	QPSK	1	0	23.33	23.71	23.68	23.0±1.0		
		1	3	23.57	23.58	23.74			
		1	5	23.51	23.67	23.62			
		3	0	22.29	22.30	22.38	22.0±1.0		
		3	2	22.28	22.20	22.35			
		3	3	22.22	22.29	22.19			
	6	0	22.20	22.26	22.23	22.0±1.0			
	16QAM	1	0	22.32	22.44	22.26	22.0±1.0		
		1	3	22.45	22.32	22.53			
		1	5	22.51	22.39	22.35			
		3	0	21.32	21.45	21.45	21.0±1.0		
		3	2	21.30	21.29	21.56			
		3	3	21.36	21.37	21.39			
		6	0	21.15	21.22	21.29	21.0±1.0		
Bandwidth	Modulation	RB size	RB offset	Channel/Frequency			Tune up		
3MHz	QPSK	1	0	23.45	23.48	23.56	23.0±1.0		
		1	7	23.33	23.40	23.62			
		1	14	23.49	23.67	23.65			
		8	0	22.50	22.45	22.68	22.0±1.0		
		8	4	22.49	22.46	22.69			
		8	7	22.40	22.63	22.71			
		15	0	22.43	22.58	22.67	22.0±1.0		
	16QAM	1	0	22.50	22.42	22.58	22.0±1.0		
		1	7	22.67	22.47	22.67			
		1	14	22.52	22.62	22.79			
		8	0	21.45	21.61	21.69	21.0±1.0		
		8	4	21.44	21.63	21.71			
		8	7	21.35	21.54	21.62			
		15	0	21.30	21.48	21.62	21.0±1.0		
		Bandwidth	Modulation	RB size	RB offset	23025/700.5	23095/707.5	23165/714.5	Tune up



LTE FDD Band 12 ANT 4				Conducted Power(dBm)			
Bandwidth	Modulation	RB size	RB offset	Channel/Frequency			Tune up
				23035/701.5	23095/707.5	23155/713.5	
5MHz	QPSK	1	0	23.41	23.45	23.63	23.0±1.0
		1	13	23.45	23.36	23.47	
		1	24	23.34	23.30	23.69	
		12	0	22.45	22.49	22.65	22.0±1.0
		12	6	22.41	22.50	22.65	
		12	13	22.38	22.51	22.71	
	25	0	22.31	22.50	22.68	22.0±1.0	
	16QAM	1	0	22.38	22.44	22.32	22.0±1.0
		1	13	21.41	22.37	22.27	
		1	24	21.27	22.48	22.42	
		12	0	21.32	21.37	21.43	21.0±1.0
		12	6	21.22	21.38	21.42	
		12	13	21.40	21.36	21.59	
	25	0	21.24	21.43	21.48	21.0±1.0	
Bandwidth	Modulation	RB size	RB offset	Channel/Frequency			Tune up
10MHz	QPSK	1	0	23.52	23.48	23.49	23.0±1.0
		1	25	23.41	23.42	23.57	
		1	49	23.39	23.64	23.72	
		25	0	22.51	22.37	22.54	22.0±1.0
		25	13	22.41	22.38	22.55	
		25	25	22.58	22.57	22.70	
	50	0	22.43	22.44	22.59	22.0±1.0	
	16QAM	1	0	22.55	22.62	22.71	22.0±1.0
		1	25	22.37	22.43	22.66	
		1	49	22.41	22.51	22.72	
		25	0	21.49	21.43	21.66	21.0±1.0
		25	13	21.53	21.59	21.67	
		25	25	21.60	21.53	21.57	
	50	0	21.46	21.48	21.57	21.0±1.0	



6. LTE Band 13 Conducted Power Test Verdict:

LTE FDD Band 13 ANT 4				Conducted Power(dBm)			Tune up
Bandwidth	Modulation	RB size	RB offset	Channel/Frequency			
				23205/779.5	23230/782.0	23255/784.5	
5MHz	QPSK	1	0	23.36	23.37	23.32	23.0±1.0
		1	13	23.41	23.58	23.61	
		1	24	23.67	23.49	23.47	
		12	0	22.60	22.63	22.56	22.0±1.0
		12	6	22.68	22.63	22.47	
		12	13	22.65	22.49	22.54	
		25	0	22.57	22.58	22.60	22.0±1.0
	16QAM	1	0	22.49	22.59	22.73	22.5±1.0
		1	13	22.47	22.62	22.83	
		1	24	22.65	22.71	22.52	
		12	0	21.52	21.42	21.28	21.0±1.0
		12	6	21.49	21.52	21.29	
		12	13	21.39	21.39	21.45	
		25	0	21.55	21.47	21.57	21.0±1.0
Bandwidth	Modulation	RB size	RB offset	Channel/Frequency			Tune up
10MHz	QPSK	1	0	/	23.44	/	23.0±1.0
		1	25	/	23.37	/	
		1	49	/	23.65	/	
		25	0	/	22.61	/	22.0±1.0
		25	13	/	22.63	/	
		25	25	/	22.59	/	
		50	0	/	22.63	/	22.0±1.0
	16QAM	1	0	/	22.58	/	22.0±1.0
		1	25	/	22.45	/	
		1	49	/	22.63	/	
		25	0	/	21.56	/	21.0±1.0
		25	13	/	21.59	/	
		25	25	/	21.53	/	
		50	0	/	21.49	/	21.0±1.0
				/	23230/782.0	/	



6. LTE Band 17 Conducted Power Test Verdict:

LTE FDD Band 17 ANT 4				Conducted Power(dBm)			Tune up
Bandwidth	Modulation	RB size	RB offset	Channel/Frequency			
				23755/706.5	23790/710.0	23825/713.5	
5MHz	QPSK	1	0	23.47	23.69	23.64	23.0±1.0
		1	13	23.63	23.62	23.45	
		1	24	23.54	23.47	23.71	
		12	0	22.43	22.65	22.61	22.0±1.0
		12	6	22.45	22.67	22.67	
		12	13	22.58	22.56	22.70	
		25	0	22.51	22.56	22.57	22.0±1.0
	16QAM	1	0	21.81	22.95	23.08	22.5±1.0
		1	13	21.79	23.09	22.70	
		1	24	21.80	22.95	23.01	
		12	0	21.40	21.52	21.41	21.0±1.0
		12	6	21.54	21.55	21.52	
		12	13	21.47	21.53	21.46	
		25	0	21.51	21.40	21.48	21.0±1.0
Bandwidth	Modulation	RB size	RB offset	Channel/Frequency			Tune up
10MHz	QPSK	1	0	23.69	23.65	23.64	23.0±1.0
		1	25	23.41	23.46	23.53	
		1	49	23.60	23.71	23.61	
		25	0	22.57	22.66	22.62	22.0±1.0
		25	13	22.58	22.67	22.63	
		25	25	22.68	22.70	22.84	
		50	0	22.68	22.63	22.79	22.0±1.0
	16QAM	1	0	23.15	22.58	22.67	22.5±1.0
		1	25	22.98	22.44	22.71	
		1	49	23.17	22.57	22.60	
		25	0	21.60	21.59	21.64	21.0±1.0
		25	13	21.60	21.57	21.43	
		25	25	21.66	21.63	21.59	
		50	0	21.54	21.37	21.55	21.0±1.0



7. LTE Band 38 Conducted Power Test Verdict:

LTE FDD Band 38 ANT 4				Conducted Power(dBm)			Tune up
Bandwidth	Modulation	RB size	RB offset	Channel/Frequency			
				37775/2572.5	38000/2595.0	38225/2617.5	
5MHz	QPSK	1	0	23.24	23.32	23.45	23.0±1.0
		1	13	23.43	23.51	23.38	
		1	24	23.32	23.44	23.44	
		12	0	22.55	22.53	22.44	22.0±1.0
		12	6	22.54	22.45	22.46	
		12	13	22.44	22.46	22.57	
		25	0	22.49	22.52	22.53	22.0±1.0
	16QAM	1	0	22.37	22.32	22.34	22.0±1.0
		1	13	22.45	22.43	22.54	
		1	24	22.52	22.33	22.56	
		12	0	21.51	21.23	21.24	21.0±1.0
		12	6	21.51	21.45	21.44	
		12	13	21.41	21.38	21.37	
		25	0	21.46	21.44	21.46	21.0±1.0
Bandwidth	Modulation	RB size	RB offset	Channel/Frequency			Tune up
10MHz	QPSK	1	0	23.57	23.37	23.70	23.0±1.0
		1	25	23.66	23.57	23.41	
		1	49	23.45	23.51	23.53	
		25	0	22.62	22.58	22.66	22.0±1.0
		25	13	22.60	22.59	22.67	
		25	25	22.52	22.47	22.61	
		50	0	22.55	22.59	22.49	22.0±1.0
	16QAM	1	0	22.31	22.47	22.48	22.0±1.0
		1	25	22.47	22.56	22.35	
		1	49	22.66	22.63	22.39	
		25	0	21.40	21.45	21.53	21.0±1.0
		25	13	21.49	21.44	21.53	
		25	25	21.36	21.34	21.48	
		50	0	21.44	21.34	21.39	21.0±1.0



LTE FDD Band 38 ANT 4				Conducted Power(dBm)			
Bandwidth	Modulation	RB size	RB offset	Channel/Frequency			Tune up
				37825/2577.5	38000/2595.0	38175/2612.5	
15MHz	QPSK	1	0	23.61	23.32	23.68	23.0±1.0
		1	38	23.70	23.56	23.50	
		1	74	23.50	23.58	23.71	
		36	0	22.48	22.54	22.58	22.0±1.0
		36	18	22.53	22.55	22.55	
		36	39	22.55	22.34	22.48	
		75	0	22.58	22.40	22.45	22.0±1.0
	16QAM	1	0	22.41	22.34	22.61	22.0±1.0
		1	38	22.33	22.53	22.59	
		1	74	22.44	22.57	22.43	
		36	0	21.49	22.55	22.47	21.0±1.0
		36	18	21.43	22.55	22.38	
		36	39	21.55	22.43	22.51	
		75	0	21.43	21.45	21.41	21.0±1.0
Bandwidth	Modulation	RB size	RB offset	Channel/Frequency			Tune up
20MHz	QPSK	1	0	23.48	23.37	23.52	23.0±1.0
		1	50	23.37	23.42	23.44	
		1	99	23.56	23.38	23.49	
		50	0	22.53	22.50	22.39	22.0±1.0
		50	25	22.54	22.51	22.40	
		50	50	22.49	22.45	22.52	
		100	0	22.50	22.41	22.41	22.0±1.0
	16QAM	1	0	22.47	22.42	22.42	22.0±1.0
		1	50	22.53	22.68	22.35	
		1	99	22.50	22.64	22.47	
		50	0	21.50	21.58	21.37	21.0±1.0
		50	25	21.55	21.45	21.43	
		50	50	21.57	21.49	21.51	
		100	0	21.56	21.39	21.38	21.0±1.0



8. LTE Band 41 Conducted Power Test Verdict:

LTE FDD Band 41 ANT 4				Conducted Power(dBm)			
Bandwidth	Modulation	RB size	RB offset	Channel/Frequency			Tune up
				39675/2498.5	40620/2593.0	41565/2687.5	
5MHz	QPSK	1	0	23.31	23.35	23.48	23.0±1.0
		1	13	23.38	23.32	23.57	
		1	24	23.42	23.20	23.60	
		12	0	22.44	22.54	22.66	22.0±1.0
		12	6	22.49	22.51	22.67	
		12	13	22.37	22.58	22.70	
		25	0	22.46	22.53	22.59	22.0±1.0
	16QAM	1	0	22.38	22.53	22.65	22.0±1.0
		1	13	22.58	22.62	22.71	
		1	24	22.46	22.65	22.53	
		12	0	21.46	21.63	21.67	21.0±1.0
		12	6	21.51	21.55	21.68	
		12	13	21.40	21.50	21.70	
		25	0	21.45	21.65	21.58	21.0±1.0
Bandwidth	Modulation	RB size	RB offset	Channel/Frequency			Tune up
				39700/2501.0	40620/2593.0	41540/2685.0	
10MHz	QPSK	1	0	23.49	23.56	23.65	23.0±1.0
		1	25	23.57	23.61	23.68	
		1	49	23.45	23.51	23.59	
		25	0	22.51	22.69	22.71	22.0±1.0
		25	13	22.52	22.69	22.69	
		25	25	22.49	22.64	22.77	
		50	0	22.47	22.60	22.68	22.0±1.0
	16QAM	1	0	22.36	22.42	22.54	22.0±1.0
		1	25	22.41	22.53	22.50	
		1	49	22.56	22.61	22.65	
		25	0	21.42	21.53	21.74	21.0±1.0
		25	13	21.35	21.58	21.67	
		25	25	21.34	21.45	21.74	
		50	0	21.40	21.51	21.70	21.0±1.0



LTE FDD Band 41 ANT 4				Conducted Power(dBm)			
Bandwidth	Modulation	RB size	RB offset	Channel/Frequency			Tune up
				39725/2503.5	40620/2593.0	41515/2682.5	
15MHz	QPSK	1	0	23.49	23.53	23.70	23.0±1.0
		1	38	23.44	23.68	23.74	
		1	74	23.37	23.56	23.68	
		36	0	22.37	22.49	22.52	22.0±1.0
		36	18	22.46	22.46	22.51	
		36	39	22.29	22.17	22.41	
		75	0	22.30	22.54	22.49	22.0±1.0
	16QAM	1	0	22.49	22.32	22.41	22.0±1.0
		1	38	22.58	22.46	22.51	
		1	74	22.45	22.35	22.11	
		36	0	21.39	21.49	21.51	21.0±1.0
		36	18	21.48	21.46	21.45	
		36	39	21.47	21.33	21.42	
		75	0	21.30	21.35	21.38	21.0±1.0
Bandwidth	Modulation	RB size	RB offset	Channel/Frequency			Tune up
				39750/2506.0	40620/2593.0	41490/2680.0	
20MHz	QPSK	1	0	23.32	23.29	23.51	23.0±1.0
		1	50	23.36	23.41	23.46	
		1	99	23.48	23.34	23.39	
		50	0	22.53	22.55	22.55	22.0±1.0
		50	25	22.47	22.64	22.46	
		50	50	22.35	22.53	22.69	
		100	0	22.32	22.56	22.49	22.0±1.0
	16QAM	1	0	22.41	22.38	22.52	22.0±1.0
		1	50	22.33	22.57	22.49	
		1	99	22.57	22.40	22.68	
		50	0	21.52	21.70	21.55	21.0±1.0
		50	25	21.56	21.70	21.61	
		50	50	21.39	21.65	21.59	
		100	0	21.42	21.73	21.55	21.0±1.0





## 7.4 WIFI Conducted Power

## Wi-Fi 2.4G Output power ANT 2

2.4G WI-FI Channel/Freq.(MHz)	Output Power (dBm)		
	802.11b	802.11g	802.11n(HT20)
1/2412.0	16.92	15.57	14.45
6/2437.0	16.81	15.62	14.49
11/2462.0	17.04	15.76	14.56

2.4G WI-FI Channel/Freq.(MHz)	Output Power (dBm)
	802.11n(HT40)
3/2422.0	14.97
6/2437.0	14.97
9/2452.0	15.07

## Wi-Fi U-NII-1 Output power ANT 2

Channel/Freq.(MHz)	Output Power (dBm)		
	802.11 a	802.11 n20	802.11 ac20
36/5180.0	16.21	14.99	14.90
44/5220.0	16.50	15.26	15.19
48/5240.0	15.94	15.02	15.11

Channel/Freq.(MHz)	Output Power (dBm)	
	802.11 n40	802.11 ac40
38/5190.0	15.98	16.12
46/5230.0	16.27	16.14

Channel/Freq.(MHz)	Output Power (dBm)
	802.11 ac80
42/5210.0	15.84



## Wi-Fi U-NII-2A Output power ANT 2

Channel/Freq.(MHz)	Output Power (dBm)		
	802.11 a	802.11 n20	802.11 ac20
52/5260.0	16.65	15.61	15.62
60/5300.0	16.59	15.52	15.59
64/5320.0	16.51	15.55	15.46

Channel/Freq.(MHz)	Output Power (dBm)	
	802.11 n40	802.11 ac40
54/5270.0	15.45	15.41
62/5310.0	15.32	15.28

Channel/Freq.(MHz)	Output Power (dBm)
	802.11 ac80
58/5290.0	15.00

## Wi-Fi U-NII-2C Output power ANT 2

Channel/Freq.(MHz)	Output Power (dBm)		
	802.11 a	802.11 n20	802.11 ac20
100/5500.0	16.32	15.28	15.33
120/5600.0	16.72	15.81	15.83
140/5700.0	17.10	16.08	16.06

Channel/Freq.(MHz)	Output Power (dBm)	
	802.11 n40	802.11 ac40
102/5510.0	15.07	15.08
118/5590.0	15.47	15.43
134/5670.0	16.18	16.10

Channel/Freq.(MHz)	Output Power (dBm)
	802.11 ac80
106/5530.0	14.84
122/5610.0	15.56



## Wi-Fi U-NII-3 Output power ANT 2

Channel/Freq.(MHz)	Output Power (dBm)		
	802.11 a	802.11 n20	802.11 ac20
149/5745.0	16.04	14.99	15.14
157/5785.0	16.15	14.90	15.08
165/5825.0	15.83	14.72	14.87

Channel/Freq.(MHz)	Output Power (dBm)	
	802.11 n40	802.11 ac40
151/5755.0	15.10	15.02
159/5795.0	15.06	14.99

Channel/Freq.(MHz)	Output Power (dBm)
	802.11 ac80
155/5775.0	14.72

## 7.5 Bluetooth Output Power

## Bluetooth Output power ANT 2

Channel	Frequency (MHz)	Output Power(dBm)		
		GFSK	$\pi/4$ -DQPSK	8-DPSK
CH 0	2402	9.87	9.34	9.72
CH 39	2441	9.75	9.05	9.38
CH 78	2480	10.32	9.85	10.00

Channel	Frequency (MHz)	BLE Output Power(dBm)	
		1M(GFSK)	2M(GFSK)
CH 0	2402	3.22	3.37
CH 19	2440	3.47	3.70
CH 39	2480	5.63	5.77

### 8. Antenna Location:



Antenna	Test Band
ANT 2	2.4GWIFI,5GWIFI,BT
ANT 4	GSM 850 / 1900,WCDMA 850 / 1700 / 1900, LTE Band 2 / 4 / 5 / 7 / 38 / 41,



Antenna-to-User (Edge Side) distance (mm):

Antenna	Front	Back	Left	Right	Top	Bottom
ANT 2	<25	<25	>25	<25	<25	>25
ANT 4	<25	<25	<25	<25	>25	<25

Note:

1. Overall (Length x Width x High): 167 mm x 75.5 mm x 11.0 mm
2. Overall Diagonal: 167.5 mm / Display Diagonal: 140 mm

The Body SAR measurement positions of each band are as below:

Antenna	Front	Back	Left	Right	Top	Bottom
ANT 2 Body	Yes	Yes	No	Yes	Yes	No
ANT 4 Body	Yes	Yes	Yes	Yes	No	Yes

Note:

1. According to KDB 941225 D06 v02r01, when antenna-to-edge>2.5cm, SAR is not required.
2. The other Frequencies were measured at the worst position



### 9. Scaling Factor calculation

Operation Mode	Channel /Frequency	Output Power(dBm)	Tune up Power in tolerance (dBm)	Max. Tune up(dBm)	Scaling Factor
GSM850 ANT 4	128/824.2	32.67	32.0 ± 1.0	33.00	1.079
	190/836.6	32.97	32.5 ± 1.0	33.50	1.130
	251/848.8	32.80	32.5 ± 1.0	33.50	1.175
GPRS850 (GPRS 4Tx) ANT 4	128/824.2	28.08	27.5 ± 1.0	28.50	1.102
	190/836.6	28.47	28.0 ± 1.0	29.00	1.130
	251/848.8	28.75	28.0 ± 1.0	29.00	1.059
GSM1900 ANT 4	512/1850.2	30.04	29.5 ± 1.0	30.50	1.112
	661/1880.0	30.20	29.5 ± 1.0	30.50	1.072
	810/1909.8	29.96	29.5 ± 1.0	30.50	1.132
GPRS1900 (GPRS 4Tx) ANT 4	512/1850.2	25.69	25.0 ± 1.0	26.00	1.074
	661/1880.0	25.98	25.5 ± 1.0	26.50	1.127
	810/1909.8	25.78	25.5 ± 1.0	26.50	1.180
WCDMA850 ANT 4	4132/826.4	22.80	22.5 ± 1.0	23.50	1.175
	4183/836.6	22.73	22.0 ± 1.0	23.00	1.064
	4233/846.6	22.67	22.0 ± 1.0	23.00	1.079
WCDMA1900 ANT 4	9262/1852.4	23.25	22.5 ± 1.0	23.50	1.059
	9400/1880.0	23.43	23.0 ± 1.0	24.00	1.140
	9538/1907.6	23.14	22.5 ± 1.0	23.50	1.086
LTE B2 20MHz 1RB#0 ANT 4	18700/1860.0	23.35	23.0 ± 1.0	24.00	1.161
	18900/1880.0	23.33	23.0 ± 1.0	24.00	1.167
	19100/1900.0	23.10	22.5 ± 1.0	23.50	1.096
LTE B2 20MHz 50%RB#0 ANT 4	18700/1860.0	22.45	22.0 ± 1.0	23.00	1.135
	18900/1880.0	22.63	22.0 ± 1.0	23.00	1.089
	19100/1900.0	22.38	22.0 ± 1.0	23.00	1.153
LTE B4 20MHz 1RB#0 ANT 4	20050/1720.0	23.58	23.0 ± 1.0	24.00	1.102
	20175/1732.5	23.42	23.0 ± 1.0	24.00	1.143
	20300/1745.0	23.35	23.0 ± 1.0	24.00	1.161
LTE B4 20MHz 50%RB#0 ANT 4	20050/1720.0	22.35	22.0 ± 1.0	23.00	1.161
	20175/1732.5	22.51	22.0 ± 1.0	23.00	1.119
	20300/1745.0	22.48	22.0 ± 1.0	23.00	1.127
LTE B5 10MHz 1RB#0 ANT 4	20450/829.0	23.60	23.0 ± 1.0	24.00	1.096
	20525/836.5	23.42	23.0 ± 1.0	24.00	1.143
	20600/844.0	23.38	23.0 ± 1.0	24.00	1.153



LTE B5 10MHz 50%RB#0 ANT 4	20450/829.0	22.73	22.0 ±1.0	23.00	1.064
	20525/836.5	22.62	22.0 ±1.0	23.00	1.091
	20600/844.0	22.66	22.0 ±1.0	23.00	1.081
LTE B7 20MHz 1RB#0 ANT 4	20850/2510.0	23.37	23.0 ±1.0	24.00	1.156
	21100/2535.0	23.22	22.5 ±1.0	23.50	1.067
	21350/2560.0	23.45	23.0 ±1.0	24.00	1.135
LTE B7 20MHz 50%RB#0 ANT 4	20850/2510.0	22.34	22.0 ±1.0	23.00	1.164
	21100/2535.0	22.60	22.0 ±1.0	23.00	1.096
	21350/2560.0	22.62	22.0 ±1.0	23.00	1.091
LTE B7 20MHz 100%RB#0 ANT 4	20850/2510.0	22.34	22.0 ±1.0	23.00	1.164
	21100/2535.0	22.53	22.0 ±1.0	23.00	1.114
	21350/2560.0	22.59	22.0 ±1.0	23.00	1.099
LTE B12 10MHz 1RB#0 ANT 4	23060/704.0	23.52	23.0 ±1.0	24.00	1.117
	23095/707.5	23.48	23.0 ±1.0	24.00	1.127
	23130/711.0	23.49	23.0 ±1.0	24.00	1.125
LTE B12 10MHz 50%RB#0 ANT 4	23060/704.0	22.51	22.0 ±1.0	23.00	1.119
	23095/707.5	22.37	22.0 ±1.0	23.00	1.156
	23130/711.0	22.54	22.0 ±1.0	23.00	1.112
LTE B13 10MHz 1RB#0 ANT 4	23230/782.0	23.44	23.0±1.0	24.00	1.138
LTE B13 10MHz 50%RB#0 ANT 4	23230/782.0	22.61	22.0±1.0	23.00	1.094
LTE B17 10MHz 1RB#0 ANT 4	23780/709.0	23.69	23.0 ±1.0	24.00	1.074
	23790/710.0	23.65	23.0 ±1.0	24.00	1.084
	23800/711.0	23.64	23.0 ±1.0	24.00	1.086
LTE B17 10MHz 50%RB#0 ANT 4	23780/709.0	22.57	22.0 ±1.0	23.00	1.104
	23790/710.0	22.66	22.0 ±1.0	23.00	1.081
	23800/711.0	22.62	22.0 ±1.0	23.00	1.091
LTE B38 20MHz 1RB#0 ANT 4	37850/2580.0	23.48	23.0 ±1.0	24.00	1.127
	38000/2595.0	23.37	23.0 ±1.0	24.00	1.156
	38150/2610.0	23.52	23.0 ±1.0	24.00	1.117
LTE B38 20MHz 50%RB#0 ANT 4	37850/2580.0	22.53	22.0 ±1.0	23.00	1.114
	38000/2595.0	22.50	22.0 ±1.0	23.00	1.122
	38150/2610.0	22.39	22.0 ±1.0	23.00	1.151



LTE B41 20MHz 1RB#0 ANT 4	39750/2506.0	23.32	23.0 ±1.0	24.00	1.169
	40620/2593.0	23.29	23.0 ±1.0	24.00	1.178
	41490/2680.0	23.51	23.0 ±1.0	24.00	1.119
LTE B41 20MHz 50%RB#0 ANT 4	39750/2506.0	22.53	22.0 ±1.0	23.00	1.114
	40620/2593.0	22.55	22.0 ±1.0	23.00	1.109
	41490/2680.0	22.55	22.0 ±1.0	23.00	1.109
WIFI 2.4G 802.11b ANT 2	1/2412.0	16.92	16.5 ±1.0	17.50	1.143
	6/2437.0	16.81	16.5 ±1.0	17.50	1.172
	11/2462.0	17.04	16.5 ±1.0	17.50	1.112
WIFI U-NII 1 802.11a ANT 2	36/5180.0	16.21	15.5 ±1.0	16.50	1.069
	44/5220.0	16.50	16.0 ±1.0	17.00	1.122
	48/5240.0	15.94	15.5 ±1.0	16.50	1.138
WIFI U-NII 2a 802.11a ANT 2	52/5260.0	16.65	16.0 ±1.0	17.00	1.084
	60/5300.0	16.59	16.0 ±1.0	17.00	1.099
	64/5320.0	16.51	16.0 ±1.0	17.00	1.119
WIFI U-NII 2c 802.11a ANT 2	100/5500.0	16.32	16.0 ±1.0	17.00	1.169
	120/5600.0	16.72	16.0 ±1.0	17.00	1.067
	140/5700.0	17.10	16.5 ±1.0	17.50	1.096
WIFI U-NII 3 802.11a ANT 2	149/5745.0	16.04	15.5 ±1.0	16.50	1.112
	157/5785.0	16.15	15.5 ±1.0	16.50	1.084
	165/5825.0	15.83	15.5 ±1.0	16.50	1.167
BT ANT 2	0/2402.0	9.87	9.5 ±1.0	10.50	1.156
	39/2441.0	9.75	9.0 ±1.0	10.00	1.059
	78/2480.0	10.32	9.5 ±1.0	10.50	1.042

Note: for LTE power tolerance, only QPSK modulation mode was provide here.





## 10. Test Results

### Results overview of GSM850

ANT 4

Test Position (0mm distance)	RF Exposure Condition	Channel /Frequency	Mode	SAR Value (W/kg)1-g	Power drift(%)	Scaled Factor	Scaled SAR (W/Kg)1-g	Limit (W/kg)	SAR Plot.
Right Cheek	Head	4183/836.6	Voice	0.096	0.45	1.130	0.108	1.6	/
Right Tilted	Head	4183/836.6	Voice	0.027	-0.74	1.130	0.031	1.6	/
Left Cheek	Head	4183/836.6	Voice	<b>0.138</b>	-2.47	1.130	<b>0.156</b>	1.6	1
Left Tilted	Head	4183/836.6	Voice	0.042	1.62	1.130	0.047	1.6	/
Test Position (10mm distance)	RF Exposure Condition	Channel /Frequency	Mode	SAR Value (W/kg)1-g	Power drift(%)	Scaled Factor	Scaled SAR (W/Kg)1-g	Limit (W/kg)	SAR Plot.
Front Upward	Body & Hotspot	4183/836.6	GPRS 4Tx	0.102	-2.38	1.130	0.115	1.6	/
Back Upward	Body & Hotspot	4183/836.6	GPRS 4Tx	<b>0.214</b>	1.75	1.130	<b>0.242</b>	1.6	2
Left	Hotspot	4183/836.6	GPRS 4Tx	0.081	0.16	1.130	0.092	1.6	/
Right	Hotspot	4183/836.6	GPRS 4Tx	0.096	-1.01	1.130	0.108	1.6	/
Bottom	Hotspot	4183/836.6	GPRS 4Tx	0.155	-3.37	1.130	0.175	1.6	/

**Results overview of GSM1900**

ANT 4

Test Position (0mm distance)	RF Exposure Condition	Channel /Frequency	Mode	SAR Value (W/kg)1-g	Power drift(%)	Scaled Factor	Scaled SAR (W/Kg)1-g	Limit (W/kg)	SAR Plot.
Right Cheek	Head	661/1880.0	Voice	0.078	0.97	1.072	0.084	1.6	/
Right Tilted	Head	661/1880.0	Voice	0.022	2.20	1.072	0.024	1.6	/
Left Cheek	Head	661/1880.0	Voice	<b>0.109</b>	-0.39	1.072	<b>0.117</b>	1.6	3
Left Tilted	Head	661/1880.0	Voice	0.031	-3.22	1.072	0.033	1.6	/
Test Position (10mm distance)	RF Exposure Condition	Channel /Frequency	Mode	SAR Value (W/kg)1-g	Power drift(%)	Scaled Factor	Scaled SAR (W/Kg)1-g	Limit (W/kg)	SAR Plot.
Front Upward	Body & Hotspot	661/1880.0	GPRS 4Tx	0.275	-0.96	1.127	0.310	1.6	/
Back Upward	Body & Hotspot	661/1880.0	GPRS 4Tx	<b>0.652</b>	-3.23	1.127	<b>0.735</b>	1.6	4
Left	Hotspot	661/1880.0	GPRS 4Tx	0.139	-2.41	1.127	0.157	1.6	/
Right	Hotspot	661/1880.0	GPRS 4Tx	0.179	1.10	1.127	0.202	1.6	/
Bottom	Hotspot	661/1880.0	GPRS 4Tx	0.546	0.81	1.127	0.615	1.6	/

**Results overview of WCDMA850**

ANT 4

Test Position (0mm distance)	RF Exposure Condition	Channel /Frequency	Mode	SAR Value (W/kg)1-g	Power drift(%)	Scaled Factor	Scaled SAR (W/Kg)1-g	Limit (W/kg)	SAR Plot.
Right Cheek	Head	4183/836.6	RMC	0.074	0.42	1.064	0.079	1.6	/
Right Tilted	Head	4183/836.6	RMC	0.023	-2.82	1.064	0.024	1.6	/
Left Cheek	Head	4183/836.6	RMC	<b>0.113</b>	-1.55	1.064	<b>0.120</b>	1.6	5
Left Tilted	Head	4183/836.6	RMC	0.034	-2.33	1.064	0.036	1.6	/
Test Position (10mm distance)	RF Exposure Condition	Channel /Frequency	Mode	SAR Value (W/kg)1-g	Power drift(%)	Scaled Factor	Scaled SAR (W/Kg)1-g	Limit (W/kg)	SAR Plot.
Front Upward	Body & Hotspot	4183/836.6	RMC	0.119	-0.22	1.064	0.127	1.6	/
Back Upward	Body & Hotspot	4183/836.6	RMC	<b>0.202</b>	-2.68	1.064	<b>0.215</b>	1.6	6
Left	Hotspot	4183/836.6	RMC	0.096	-0.40	1.064	0.102	1.6	/
Right	Hotspot	4183/836.6	RMC	0.083	3.63	1.064	0.088	1.6	/
Bottom	Hotspot	4183/836.6	RMC	0.139	-0.56	1.064	0.148	1.6	/

**Results overview of WCDMA1900**

ANT 4

Test Position (0mm distance)	RF Exposure Condition	Channel /Frequency	Mode	SAR Value (W/kg)1-g	Power drift(%)	Scaled Factor	Scaled SAR (W/Kg)1-g	Limit (W/kg)	SAR Plot.
Right Cheek	Head	9400/1880.0	RMC	0.102	-0.25	1.140	0.116	1.6	/
Right Tilted	Head	9400/1880.0	RMC	0.031	0.80	1.140	0.035	1.6	/
Left Cheek	Head	9400/1880.0	RMC	<b>0.142</b>	-0.76	1.140	<b>0.162</b>	1.6	7
Left Tilted	Head	9400/1880.0	RMC	0.040	-2.18	1.140	0.046	1.6	/
Test Position (10mm distance)	RF Exposure Condition	Channel /Frequency	Mode	SAR Value (W/kg)1-g	Power drift(%)	Scaled Factor	Scaled SAR (W/Kg)1-g	Limit (W/kg)	SAR Plot.
Front Upward	Body & Hotspot	9400/1880.0	RMC	0.284	-2.26	1.140	0.324	1.6	/
Back Upward	Body & Hotspot	9400/1880.0	RMC	<b>0.621</b>	0.60	1.140	<b>0.708</b>	1.6	8
Left	Hotspot	9400/1880.0	RMC	0.121	3.03	1.140	0.138	1.6	/
Right	Hotspot	9400/1880.0	RMC	0.181	-0.91	1.140	0.206	1.6	/
Bottom	Hotspot	9400/1880.0	RMC	0.520	-2.88	1.140	0.593	1.6	/



**Results overview of FDD LTE Band 2, QPSK, 20MHz Bandwidth**

ANT 4

Test Position (0mm distance)	RF Exposure Condition	Channel /Frequency	Mode	SAR Value (W/kg)1-g	Power drift(%)	Scaled Factor	Scaled SAR (W/Kg)1-g	Limit (W/kg)	SAR Plot.
1RB#0									
Right Cheek	Head	18900/1880.0	QPSK	0.096	-1.42	1.167	0.112	1.6	/
Right Tilted	Head	18900/1880.0	QPSK	0.027	-2.18	1.167	0.032	1.6	/
Left Cheek	Head	18900/1880.0	QPSK	<b>0.134</b>	0.72	1.167	<b>0.156</b>	1.6	9
Left Tilted	Head	18900/1880.0	QPSK	0.041	1.17	1.167	0.048	1.6	/
50%RB#0									
Right Cheek	Head	18900/1880.0	QPSK	0.078	0.61	1.153	0.090	1.6	/
Right Tilted	Head	18900/1880.0	QPSK	0.021	-2.96	1.153	0.024	1.6	/
Left Cheek	Head	18900/1880.0	QPSK	0.109	-1.55	1.153	0.126	1.6	/
Left Tilted	Head	18900/1880.0	QPSK	0.033	-0.64	1.153	0.038	1.6	/
Test Position (10mm distance)	RF Exposure Condition	Channel /Frequency	Mode	SAR Value (W/kg)1-g	Power drift(%)	Scaled Factor	Scaled SAR (W/Kg)1-g	Limit (W/kg)	SAR Plot.
1RB#0									
Front Upward	Body & Hotspot	18900/1880.0	QPSK	0.301	0.82	1.167	0.351	1.6	/
Back Upward	Body & Hotspot	18900/1880.0	QPSK	0.623	-2.75	1.167	0.727	1.6	/
Left	Hotspot	18900/1880.0	QPSK	0.152	-0.73	1.167	0.177	1.6	/
Right	Hotspot	18900/1880.0	QPSK	0.201	-2.20	1.167	0.235	1.6	/
Bottom	Hotspot	18900/1880.0	QPSK	<b>0.644</b>	1.51	1.167	<b>0.752</b>	1.6	10
50%RB#0									
Front Upward	Body & Hotspot	18900/1880.0	QPSK	0.228	-1.60	1.153	0.263	1.6	/
Back Upward	Body & Hotspot	18900/1880.0	QPSK	0.529	-0.52	1.153	0.610	1.6	/
Left	Hotspot	18900/1880.0	QPSK	0.116	-2.30	1.153	0.134	1.6	/
Right	Hotspot	18900/1880.0	QPSK	0.143	-0.38	1.153	0.165	1.6	/
Bottom	Hotspot	18900/1880.0	QPSK	0.551	-0.29	1.153	0.635	1.6	/



**Results overview of FDD LTE Band 4, QPSK, 20MHz Bandwidth**

ANT 4

Test Position (0mm distance)	RF Exposure Condition	Channel /Frequency	Mode	SAR Value (W/kg)1-g	Power drift(%)	Scaled Factor	Scaled SAR (W/Kg)1-g	Limit (W/kg)	SAR Plot.
1RB#0									
Right Cheek	Head	20175/1732.5	QPSK	0.130	-0.53	1.143	0.149	1.6	/
Right Tilted	Head	20175/1732.5	QPSK	0.037	-2.24	1.143	0.042	1.6	/
Left Cheek	Head	20175/1732.5	QPSK	<b>0.182</b>	1.25	1.143	<b>0.208</b>	1.6	11
Left Tilted	Head	20175/1732.5	QPSK	0.046	2.66	1.143	0.053	1.6	/
50%RB#0									
Right Cheek	Head	20175/1732.5	QPSK	0.110	-0.17	1.119	0.123	1.6	/
Right Tilted	Head	20175/1732.5	QPSK	0.031	-1.43	1.119	0.035	1.6	/
Left Cheek	Head	20175/1732.5	QPSK	0.154	-2.71	1.119	0.172	1.6	/
Left Tilted	Head	20175/1732.5	QPSK	0.039	0.70	1.119	0.044	1.6	/
Test Position (10mm distance)	RF Exposure Condition	Channel /Frequency	Mode	SAR Value (W/kg)1-g	Power drift(%)	Scaled Factor	Scaled SAR (W/Kg)1-g	Limit (W/kg)	SAR Plot.
1RB#0									
Front Upward	Body & Hotspot	20175/1732.5	QPSK	0.268	2.26	1.143	0.306	1.6	/
Back Upward	Body & Hotspot	20175/1732.5	QPSK	0.604	-0.75	1.143	0.690	1.6	/
Left	Hotspot	20175/1732.5	QPSK	0.130	0.24	1.143	0.149	1.6	/
Right	Hotspot	20175/1732.5	QPSK	0.167	-3.32	1.143	0.191	1.6	/
Bottom	Hotspot	20175/1732.5	QPSK	<b>0.630</b>	-2.49	1.143	<b>0.720</b>	1.6	12
50%RB#0									
Front Upward	Body & Hotspot	20175/1732.5	QPSK	0.201	-1.64	1.119	0.225	1.6	/
Back Upward	Body & Hotspot	20175/1732.5	QPSK	0.482	-0.90	1.119	0.539	1.6	/
Left	Hotspot	20175/1732.5	QPSK	0.103	-2.97	1.119	0.115	1.6	/
Right	Hotspot	20175/1732.5	QPSK	0.121	1.81	1.119	0.135	1.6	/
Bottom	Hotspot	20175/1732.5	QPSK	0.519	0.33	1.119	0.581	1.6	/



**Results overview of FDD LTE Band 5, QPSK, 10MHz Bandwidth**

ANT 4

Test Position (0mm distance)	RF Exposure Condition	Channel /Frequency	Mode	SAR Value (W/kg)1-g	Power drift(%)	Scaled Factor	Scaled SAR (W/Kg)1-g	Limit (W/kg)	SAR Plot.
1RB#0									
Right Cheek	Head	20525/836.5	QPSK	0.071	3.07	1.143	0.081	1.6	/
Right Tilted	Head	20525/836.5	QPSK	0.023	-0.64	1.143	0.026	1.6	/
Left Cheek	Head	20525/836.5	QPSK	<b>0.099</b>	-2.43	1.143	<b>0.113</b>	1.6	13
Left Tilted	Head	20525/836.5	QPSK	0.032	-3.22	1.143	0.037	1.6	/
50%RB#0									
Right Cheek	Head	20525/836.5	QPSK	0.060	0.50	1.091	0.065	1.6	/
Right Tilted	Head	20525/836.5	QPSK	0.018	-3.61	1.091	0.020	1.6	/
Left Cheek	Head	20525/836.5	QPSK	0.086	-1.02	1.091	0.094	1.6	/
Left Tilted	Head	20525/836.5	QPSK	0.028	2.41	1.091	0.031	1.6	/
Test Position (10mm distance)	RF Exposure Condition	Channel /Frequency	Mode	SAR Value (W/kg)1-g	Power drift(%)	Scaled Factor	Scaled SAR (W/Kg)1-g	Limit (W/kg)	SAR Plot.
1RB#0									
Front Upward	Body & Hotspot	20525/836.5	QPSK	0.123	-1.13	1.143	0.141	1.6	/
Back Upward	Body & Hotspot	20525/836.5	QPSK	<b>0.197</b>	0.85	1.143	<b>0.225</b>	1.6	14
Left	Hotspot	20525/836.5	QPSK	0.066	-3.69	1.143	0.075	1.6	/
Right	Hotspot	20525/836.5	QPSK	0.053	2.54	1.143	0.061	1.6	/
Bottom	Hotspot	20525/836.5	QPSK	0.166	-0.17	1.143	0.190	1.6	/
50%RB#0									
Front Upward	Body & Hotspot	20525/836.5	QPSK	0.098	1.09	1.091	0.107	1.6	/
Back Upward	Body & Hotspot	20525/836.5	QPSK	0.152	-2.13	1.091	0.166	1.6	/
Left	Hotspot	20525/836.5	QPSK	0.051	-0.91	1.091	0.056	1.6	/
Right	Hotspot	20525/836.5	QPSK	0.040	-3.70	1.091	0.044	1.6	/
Bottom	Hotspot	20525/836.5	QPSK	0.122	1.82	1.091	0.133	1.6	/



**Results overview of FDD LTE Band 7, QPSK, 20MHz Bandwidth**

ANT 4

Test Position (0mm distance)	RF Exposure Condition	Channel /Frequency	Mode	SAR Value (W/kg)1-g	Power drift(%)	Scaled Factor	Scaled SAR (W/Kg)1-g	Limit (W/kg)	SAR Plot.
1RB#0									
Right Cheek	Head	21100/2535.0	QPSK	0.049	3.35	1.067	0.052	1.6	/
Right Tilted	Head	21100/2535.0	QPSK	0.017	-2.24	1.067	0.018	1.6	/
Left Cheek	Head	21100/2535.0	QPSK	<b>0.072</b>	-0.89	1.067	<b>0.077</b>	1.6	15
Left Tilted	Head	21100/2535.0	QPSK	0.024	-1.68	1.067	0.026	1.6	/
50%RB#0									
Right Cheek	Head	21100/2535.0	QPSK	0.042	1.01	1.096	0.046	1.6	/
Right Tilted	Head	21100/2535.0	QPSK	0.014	-1.24	1.096	0.015	1.6	/
Left Cheek	Head	21100/2535.0	QPSK	0.062	-2.63	1.096	0.068	1.6	/
Left Tilted	Head	21100/2535.0	QPSK	0.019	0.92	1.096	0.021	1.6	/
Test Position (10mm distance)	RF Exposure Condition	Channel /Frequency	Mode	SAR Value (W/kg)1-g	Power drift(%)	Scaled Factor	Scaled SAR (W/Kg)1-g	Limit (W/kg)	SAR Plot.
1RB#0									
Front Upward	Body & Hotspot	21100/2535.0	QPSK	0.421	-2.71	1.067	0.449	1.6	/
Back Upward	Body & Hotspot	21100/2535.0	QPSK	<b>0.931</b>	0.15	1.067	0.993	1.6	16
<b>Back Upward Repeat</b>	<b>Body &amp; Hotspot</b>	<b>21100/2535.0</b>	<b>QPSK</b>	<b>0.919</b>	<b>-0.29</b>	<b>1.067</b>	<b>0.981</b>	<b>1.6</b>	/
Left	Hotspot	21100/2535.0	QPSK	0.220	0.90	1.067	0.235	1.6	/
Right	Hotspot	21100/2535.0	QPSK	0.186	-1.85	1.067	0.198	1.6	/
Bottom	Hotspot	21100/2535.0	QPSK	0.481	0.71	1.067	0.513	1.6	/
Back Upward	Body & Hotspot	20850/2510.0	QPSK	0.792	-2.24	1.156	0.916	1.6	/
Back Upward	Body & Hotspot	21350/2560.0	QPSK	0.887	1.07	1.135	1.007	1.6	/
50%RB#0									
Front Upward	Body & Hotspot	21100/2535.0	QPSK	0.336	-3.10	1.096	0.368	1.6	/
Back Upward	Body & Hotspot	21100/2535.0	QPSK	0.772	2.62	1.096	0.846	1.6	/
Left	Hotspot	21100/2535.0	QPSK	0.171	0.75	1.096	0.187	1.6	/
Right	Hotspot	21100/2535.0	QPSK	0.125	-1.18	1.096	0.137	1.6	/





Bottom	Hotspot	21100/2535.0	QPSK	0.391	0.91	1.096	0.429	1.6	/
Back Upward	Body & Hotspot	20850/2510.0	QPSK	0.695	3.33	1.164	0.809	1.6	/
Back Upward	Body & Hotspot	21350/2560.0	QPSK	0.763	-0.52	1.091	0.832	1.6	/
100%RB#0									
Front Upward	Body & Hotspot	21100/2535.0	QPSK	0.308	-2.04	1.114	0.343	1.6	/
Back Upward	Body & Hotspot	21100/2535.0	QPSK	0.761	1.76	1.114	0.848	1.6	/
Left	Hotspot	21100/2535.0	QPSK	0.152	-0.51	1.114	0.169	1.6	/
Right	Hotspot	21100/2535.0	QPSK	0.117	0.15	1.114	0.130	1.6	/
Bottom	Hotspot	21100/2535.0	QPSK	0.369	-2.33	1.114	0.411	1.6	/
Back Upward	Body & Hotspot	20850/2510.0	QPSK	0.703	2.04	1.164	0.818	1.6	/
Back Upward	Body & Hotspot	21350/2560.0	QPSK	0.792	-4.11	1.091	0.864	1.6	/



**Results overview of FDD LTE Band 12, QPSK, 10MHz Bandwidth**

ANT 4

Test Position (0mm distance)	RF Exposure Condition	Channel /Frequency	Mode	SAR Value (W/kg)1-g	Power drift(%)	Scaled Factor	Scaled SAR (W/Kg)1-g	Limit (W/kg)	SAR Plot.
1RB#0									
Right Cheek	Head	23095/707.5	QPSK	0.096	-0.37	1.127	0.108	1.6	/
Right Tilted	Head	23095/707.5	QPSK	0.029	3.81	1.127	0.033	1.6	/
Left Cheek	Head	23095/707.5	QPSK	<b>0.129</b>	-0.43	1.127	<b>0.145</b>	1.6	17
Left Tilted	Head	23095/707.5	QPSK	0.038	-2.14	1.127	0.043	1.6	/
50%RB#0									
Right Cheek	Head	23095/707.5	QPSK	0.078	-3.36	1.156	0.090	1.6	/
Right Tilted	Head	23095/707.5	QPSK	0.022	0.58	1.156	0.025	1.6	/
Left Cheek	Head	23095/707.5	QPSK	0.108	0.97	1.156	0.125	1.6	/
Left Tilted	Head	23095/707.5	QPSK	0.028	2.32	1.156	0.032	1.6	/
Test Position (10mm distance)	RF Exposure Condition	Channel /Frequency	Mode	SAR Value (W/kg)1-g	Power drift(%)	Scaled Factor	Scaled SAR (W/Kg)1-g	Limit (W/kg)	SAR Plot.
1RB#0									
Front Upward	Body & Hotspot	23095/707.5	QPSK	0.129	-3.55	1.127	0.145	1.6	/
Back Upward	Body & Hotspot	23095/707.5	QPSK	<b>0.301</b>	-2.57	1.127	<b>0.339</b>	1.6	18
Left	Hotspot	23095/707.5	QPSK	0.066	-0.49	1.127	0.074	1.6	/
Right	Hotspot	23095/707.5	QPSK	0.083	2.69	1.127	0.094	1.6	/
Bottom	Hotspot	23095/707.5	QPSK	0.282	1.95	1.127	0.318	1.6	/
50%RB#0									
Front Upward	Body & Hotspot	23095/707.5	QPSK	0.119	-1.90	1.156	0.138	1.6	/
Back Upward	Body & Hotspot	23095/707.5	QPSK	0.267	0.25	1.156	0.309	1.6	/
Left	Hotspot	23095/707.5	QPSK	0.059	-2.54	1.156	0.068	1.6	/
Right	Hotspot	23095/707.5	QPSK	0.074	1.81	1.156	0.086	1.6	/
Bottom	Hotspot	23095/707.5	QPSK	0.245	0.14	1.156	0.283	1.6	/



**Results overview of FDD LTE Band 13, QPSK, 10MHz Bandwidth**

ANT 4

Test Position (0mm distance)	RF Exposure Condition	Channel /Frequency	Mode	SAR Value (W/kg)1-g	Power drift(%)	Scaled Factor	Scaled SAR (W/Kg)1-g	Limit (W/kg)	SAR Plot.
1RB#0									
Right Cheek	Head	23230/782.0	QPSK	0.071	-0.29	1.127	0.080	1.6	/
Right Tilted	Head	23230/782.0	QPSK	0.020	-3.47	1.127	0.023	1.6	/
Left Cheek	Head	23230/782.0	QPSK	<b>0.095</b>	-0.61	1.127	<b>0.107</b>	1.6	19
Left Tilted	Head	23230/782.0	QPSK	0.030	1.13	1.127	0.034	1.6	/
50%RB#0									
Right Cheek	Head	23230/782.0	QPSK	0.059	-3.22	1.156	0.068	1.6	/
Right Tilted	Head	23230/782.0	QPSK	0.014	-0.17	1.156	0.016	1.6	/
Left Cheek	Head	23230/782.0	QPSK	0.080	2.64	1.156	0.092	1.6	/
Left Tilted	Head	23230/782.0	QPSK	0.023	0.93	1.156	0.027	1.6	/
Test Position (10mm distance)	RF Exposure Condition	Channel /Frequency	Mode	SAR Value (W/kg)1-g	Power drift(%)	Scaled Factor	Scaled SAR (W/Kg)1-g	Limit (W/kg)	SAR Plot.
1RB#0									
Front Upward	Body & Hotspot	23230/782.0	QPSK	0.113	-2.32	1.127	0.127	1.6	/
Back Upward	Body & Hotspot	23230/782.0	QPSK	<b>0.236</b>	0.45	1.127	<b>0.266</b>	1.6	20
Left	Hotspot	23230/782.0	QPSK	0.081	-1.08	1.127	0.091	1.6	/
Right	Hotspot	23230/782.0	QPSK	0.066	-3.12	1.127	0.074	1.6	/
Bottom	Hotspot	23230/782.0	QPSK	0.217	0.56	1.127	0.245	1.6	/
50%RB#0									
Front Upward	Body & Hotspot	23230/782.0	QPSK	0.101	3.47	1.156	0.117	1.6	/
Back Upward	Body & Hotspot	23230/782.0	QPSK	0.201	-3.94	1.156	0.232	1.6	/
Left	Hotspot	23230/782.0	QPSK	0.063	-2.05	1.156	0.073	1.6	/
Right	Hotspot	23230/782.0	QPSK	0.051	1.10	1.156	0.059	1.6	/
Bottom	Hotspot	23230/782.0	QPSK	0.178	-0.45	1.156	0.206	1.6	/



**Results overview of FDD LTE Band 17, QPSK, 10MHz Bandwidth**

ANT 4

Test Position (0mm distance)	RF Exposure Condition	Channel /Frequency	Mode	SAR Value (W/kg)1-g	Power drift(%)	Scaled Factor	Scaled SAR (W/Kg)1-g	Limit (W/kg)	SAR Plot.
1RB#0									
Right Cheek	Head	23790/710.0	QPSK	0.098	-2.28	1.084	0.106	1.6	/
Right Tilted	Head	23790/710.0	QPSK	0.027	-0.93	1.084	0.029	1.6	/
Left Cheek	Head	23790/710.0	QPSK	<b>0.127</b>	1.70	1.084	<b>0.138</b>	1.6	21
Left Tilted	Head	23790/710.0	QPSK	0.034	-1.92	1.084	0.037	1.6	/
50%RB#0									
Right Cheek	Head	23790/710.0	QPSK	0.076	2.77	1.081	0.082	1.6	/
Right Tilted	Head	23790/710.0	QPSK	0.021	-0.19	1.081	0.023	1.6	/
Left Cheek	Head	23790/710.0	QPSK	0.102	-2.40	1.081	0.110	1.6	/
Left Tilted	Head	23790/710.0	QPSK	0.028	-3.13	1.081	0.030	1.6	/
Test Position (10mm distance)	RF Exposure Condition	Channel /Frequency	Mode	SAR Value (W/kg)1-g	Power drift(%)	Scaled Factor	Scaled SAR (W/Kg)1-g	Limit (W/kg)	SAR Plot.
1RB#0									
Front Upward	Body & Hotspot	23790/710.0	QPSK	0.122	-1.74	1.084	0.132	1.6	/
Back Upward	Body & Hotspot	23790/710.0	QPSK	<b>0.299</b>	-0.64	1.084	<b>0.324</b>	1.6	22
Left	Hotspot	23790/710.0	QPSK	0.062	3.62	1.084	0.067	1.6	/
Right	Hotspot	23790/710.0	QPSK	0.086	-1.69	1.084	0.093	1.6	/
Bottom	Hotspot	23790/710.0	QPSK	0.262	-0.81	1.084	0.284	1.6	/
50%RB#0									
Front Upward	Body & Hotspot	23790/710.0	QPSK	0.094	-2.29	1.081	0.102	1.6	/
Back Upward	Body & Hotspot	23790/710.0	QPSK	0.226	2.35	1.081	0.244	1.6	/
Left	Hotspot	23790/710.0	QPSK	0.050	-0.97	1.081	0.054	1.6	/
Right	Hotspot	23790/710.0	QPSK	0.070	-3.05	1.081	0.076	1.6	/
Bottom	Hotspot	23790/710.0	QPSK	0.214	0.89	1.081	0.231	1.6	/



**Results overview of TDD LTE Band 38, QPSK, 20MHz Bandwidth**

ANT 4

Test Position (0mm distance)	RF Exposure Condition	Channel /Frequency	Mode	SAR Value (W/kg)1-g	Power drift(%)	Scaled Factor	Scaled SAR (W/Kg)1-g	Limit (W/kg)	SAR Plot.
1RB#0									
Right Cheek	Head	38000/2595.0	QPSK	0.029	-2.62	1.156	0.034	1.6	/
Right Tilted	Head	38000/2595.0	QPSK	0.013	-3.91	1.156	0.015	1.6	/
Left Cheek	Head	38000/2595.0	QPSK	<b>0.041</b>	0.18	1.156	<b>0.047</b>	1.6	23
Left Tilted	Head	38000/2595.0	QPSK	0.019	-0.40	1.156	0.022	1.6	/
50%RB#0									
Right Cheek	Head	38000/2595.0	QPSK	0.023	2.29	1.122	0.026	1.6	/
Right Tilted	Head	38000/2595.0	QPSK	0.010	-0.80	1.122	0.011	1.6	/
Left Cheek	Head	38000/2595.0	QPSK	0.034	-1.08	1.122	0.038	1.6	/
Left Tilted	Head	38000/2595.0	QPSK	0.015	-2.51	1.122	0.017	1.6	/
Test Position (10mm distance)	RF Exposure Condition	Channel /Frequency	Mode	SAR Value (W/kg)1-g	Power drift(%)	Scaled Factor	Scaled SAR (W/Kg)1-g	Limit (W/kg)	SAR Plot.
1RB#0									
Front Upward	Body & Hotspot	38000/2595.0	QPSK	0.220	2.68	1.156	0.254	1.6	/
Back Upward	Body & Hotspot	38000/2595.0	QPSK	<b>0.434</b>	0.32	1.156	<b>0.502</b>	1.6	24
Left	Hotspot	38000/2595.0	QPSK	0.112	-3.28	1.156	0.129	1.6	/
Right	Hotspot	38000/2595.0	QPSK	0.089	-1.28	1.156	0.103	1.6	/
Bottom	Hotspot	38000/2595.0	QPSK	0.200	-0.76	1.156	0.231	1.6	/
50%RB#0									
Front Upward	Body & Hotspot	38000/2595.0	QPSK	0.205	-3.89	1.122	0.230	1.6	/
Back Upward	Body & Hotspot	38000/2595.0	QPSK	0.392	0.30	1.122	0.440	1.6	/
Left	Hotspot	38000/2595.0	QPSK	0.101	-1.28	1.122	0.113	1.6	/
Right	Hotspot	38000/2595.0	QPSK	0.074	-3.55	1.122	0.083	1.6	/
Bottom	Hotspot	38000/2595.0	QPSK	0.172	0.84	1.122	0.193	1.6	/



**Results overview of TDD LTE Band 41, QPSK, 20MHz Bandwidth**

ANT 4

Test Position (0mm distance)	RF Exposure Condition	Channel /Frequency	Mode	SAR Value (W/kg)1-g	Power drift(%)	Scaled Factor	Scaled SAR (W/Kg)1-g	Limit (W/kg)	SAR Plot.
1RB#0									
Right Cheek	Head	40620/2593.0	QPSK	0.038	-3.53	1.178	0.045	1.6	/
Right Tilted	Head	40620/2593.0	QPSK	0.014	0.27	1.178	0.016	1.6	/
Left Cheek	Head	40620/2593.0	QPSK	<b>0.051</b>	-1.08	1.178	<b>0.060</b>	1.6	25
Left Tilted	Head	40620/2593.0	QPSK	0.019	-0.85	1.178	0.022	1.6	/
50%RB#0									
Right Cheek	Head	40620/2593.0	QPSK	0.026	1.20	1.109	0.029	1.6	/
Right Tilted	Head	40620/2593.0	QPSK	0.011	-0.93	1.109	0.012	1.6	/
Left Cheek	Head	40620/2593.0	QPSK	0.039	1.08	1.109	0.043	1.6	/
Left Tilted	Head	40620/2593.0	QPSK	0.015	-2.62	1.109	0.017	1.6	/
Test Position (10mm distance)	RF Exposure Condition	Channel /Frequency	Mode	SAR Value (W/kg)1-g	Power drift(%)	Scaled Factor	Scaled SAR (W/Kg)1-g	Limit (W/kg)	SAR Plot.
1RB#0									
Front Upward	Body & Hotspot	40620/2593.0	QPSK	0.189	0.28	1.178	0.223	1.6	/
Back Upward	Body & Hotspot	40620/2593.0	QPSK	<b>0.465</b>	-3.36	1.178	<b>0.548</b>	1.6	26
Left	Hotspot	40620/2593.0	QPSK	0.167	1.60	1.178	0.197	1.6	/
Right	Hotspot	40620/2593.0	QPSK	0.113	0.72	1.178	0.133	1.6	/
Bottom	Hotspot	40620/2593.0	QPSK	0.244	-0.29	1.178	0.287	1.6	/
50%RB#0									
Front Upward	Body & Hotspot	40620/2593.0	QPSK	0.150	-3.89	1.109	0.166	1.6	/
Back Upward	Body & Hotspot	40620/2593.0	QPSK	0.384	2.00	1.109	0.426	1.6	/
Left	Hotspot	40620/2593.0	QPSK	0.136	0.21	1.109	0.151	1.6	/
Right	Hotspot	40620/2593.0	QPSK	0.092	-3.55	1.109	0.102	1.6	/
Bottom	Hotspot	40620/2593.0	QPSK	0.189	0.48	1.109	0.210	1.6	/



**Results overview of WIFI2.4G 802.11b**

ANT 2

Test Position (0mm distance)	RF Exposure Condition	Channel /Frequency	Mode	SAR Value (W/kg)1-g	Power drift(%)	Scaled Factor	Scaled SAR (W/Kg)1-g	Limit (W/kg)	SAR Plot.
Right Cheek	Head	6/2437.0	802.11b	0.133	-2.62	1.172	0.156	1.6	/
Right Tilted	Head	6/2437.0	802.11b	0.152	-0.50	1.172	0.178	1.6	/
Left Cheek	Head	6/2437.0	802.11b	0.156	1.48	1.172	0.183	1.6	/
Left Tilted	Head	6/2437.0	802.11b	<b>0.161</b>	0.73	1.172	<b>0.189</b>	1.6	27
Test Position (10mm distance)	RF Exposure Condition	Channel /Frequency	Mode	SAR Value (W/kg)1-g	Power drift(%)	Scaled Factor	Scaled SAR (W/Kg)1-g	Limit (W/kg)	SAR Plot.
Front Upward	Body & Hotspot	6/2437.0	802.11b	0.151	0.90	1.172	0.177	1.6	/
Back Upward	Body & Hotspot	6/2437.0	802.11b	<b>0.317</b>	-1.75	1.172	<b>0.372</b>	1.6	28
Right	Hotspot	6/2437.0	802.11b	0.109	2.39	1.172	0.128	1.6	/
Top	Hotspot	6/2437.0	802.11b	0.195	0.72	1.172	0.229	1.6	/

**Results overview of WIFI U-NII 1 802.11a**

ANT 2

Test Position (0mm distance)	RF Exposure Condition	Channel /Frequency	Mode	SAR Value (W/kg)1-g	Power drift(%)	Scaled Factor	Scaled SAR (W/Kg)1-g	Limit (W/kg)	SAR Plot.
Right Cheek	Head	44/5220.0	802.11a	0.224	1.85	1.122	0.251	1.6	/
Right Tilted	Head	44/5220.0	802.11a	0.242	-1.40	1.122	0.272	1.6	/
Left Cheek	Head	44/5220.0	802.11a	0.280	2.08	1.122	0.314	1.6	/
Left Tilted	Head	44/5220.0	802.11a	<b>0.294</b>	0.45	1.122	<b>0.330</b>	1.6	29
Test Position (10mm distance)	RF Exposure Condition	Channel /Frequency	Mode	SAR Value (W/kg)1-g	Power drift(%)	Scaled Factor	Scaled SAR (W/Kg)1-g	Limit (W/kg)	SAR Plot.
Front Upward	Body	44/5220.0	802.11a	0.132	3.27	1.122	0.148	1.6	/
Back Upward	Body	44/5220.0	802.11a	<b>0.422</b>	-2.42	1.122	<b>0.473</b>	1.6	30

**Results overview of WIFI U-NII 2a 802.11a**

ANT 2

Test Position (0mm distance)	RF Exposure Condition	Channel /Frequency	Mode	SAR Value (W/kg)1-g	Power drift(%)	Scaled Factor	Scaled SAR (W/Kg)1-g	Limit (W/kg)	SAR Plot.
Right Cheek	Head	60/5300.0	802.11a	0.240	0.42	1.099	0.264	1.6	/
Right Tilted	Head	60/5300.0	802.11a	0.265	-1.83	1.099	0.291	1.6	/
Left Cheek	Head	60/5300.0	802.11a	0.303	1.02	1.099	0.333	1.6	/
Left Tilted	Head	60/5300.0	802.11a	<b>0.329</b>	-2.90	1.099	<b>0.362</b>	1.6	31
Test Position (10mm distance)	RF Exposure Condition	Channel /Frequency	Mode	SAR Value (W/kg)1-g	Power drift(%)	Scaled Factor	Scaled SAR (W/Kg)1-g	Limit (W/kg)	SAR Plot.
Front Upward	Body	60/5300.0	802.11a	0.151	-3.10	1.099	0.166	1.6	/
Back Upward	Body	60/5300.0	802.11a	<b>0.461</b>	1.41	1.099	<b>0.507</b>	1.6	32

**Results overview of WIFI U-NII 2c 802.11a**

ANT 2

Test Position (0mm distance)	RF Exposure Condition	Channel /Frequency	Mode	SAR Value (W/kg)1-g	Power drift(%)	Scaled Factor	Scaled SAR (W/Kg)1-g	Limit (W/kg)	SAR Plot.
Right Cheek	Head	120/5600.0	802.11a	0.268	-1.64	1.067	0.286	1.6	/
Right Tilted	Head	120/5600.0	802.11a	0.305	-0.96	1.067	0.325	1.6	/
Left Cheek	Head	120/5600.0	802.11a	<b>0.345</b>	-0.38	1.067	<b>0.368</b>	1.6	33
Left Tilted	Head	120/5600.0	802.11a	0.357	2.29	1.067	0.381	1.6	/
Test Position (10mm distance)	RF Exposure Condition	Channel /Frequency	Mode	SAR Value (W/kg)1-g	Power drift(%)	Scaled Factor	Scaled SAR (W/Kg)1-g	Limit (W/kg)	SAR Plot.
Front Upward	Body	120/5600.0	802.11a	0.141	-3.60	1.067	0.150	1.6	/
Back Upward	Body	120/5600.0	802.11a	<b>0.439</b>	-0.72	1.067	<b>0.468</b>	1.6	34



**Results overview of WIFI U-NII 3 802.11a**

ANT 2

Test Position (0mm distance)	RF Exposure Condition	Channel /Frequency	Mode	SAR Value (W/kg)1-g	Power drift(%)	Scaled Factor	Scaled SAR (W/Kg)1-g	Limit (W/kg)	SAR Plot.
Right Cheek	Head	157/5785.0	802.11a	0.254	-0.98	1.084	0.275	1.6	/
Right Tilted	Head	157/5785.0	802.11a	0.281	-2.37	1.084	0.305	1.6	/
Left Cheek	Head	157/5785.0	802.11a	0.306	1.16	1.084	0.332	1.6	/
Left Tilted	Head	157/5785.0	802.11a	<b>0.323</b>	-1.41	1.084	<b>0.350</b>	1.6	35
Test Position (10mm distance)	RF Exposure Condition	Channel /Frequency	Mode	SAR Value (W/kg)1-g	Power drift(%)	Scaled Factor	Scaled SAR (W/Kg)1-g	Limit (W/kg)	SAR Plot.
Front Upward	Body	157/5785.0	802.11a	0.128	0.35	1.084	0.139	1.6	/
Back Upward	Body	157/5785.0	802.11a	<b>0.397</b>	-2.00	1.084	<b>0.430</b>	1.6	36

**Results overview of BT**

ANT 2

Test Position (0mm distance)	RF Exposure Condition	Channel /Frequency	Mode	SAR Value (W/kg)1-g	Power drift(%)	Scaled Factor	Scaled SAR (W/Kg)1-g	Limit (W/kg)	SAR Plot.
Right Cheek	Head	39/2441.0	DH5	0.048	-1.82	1.059	0.051	1.6	/
Right Tilted	Head	39/2441.0	DH5	0.051	0.96	1.059	0.054	1.6	/
Left Cheek	Head	39/2441.0	DH5	0.053	2.00	1.059	0.056	1.6	/
Left Tilted	Head	39/2441.0	DH5	<b>0.058</b>	-3.43	1.059	<b>0.061</b>	1.6	37
Test Position (10mm distance)	RF Exposure Condition	Channel /Frequency	Mode	SAR Value (W/kg)1-g	Power drift(%)	Scaled Factor	Scaled SAR (W/Kg)1-g	Limit (W/kg)	SAR Plot.
Front Upward	Body	39/2441.0	DH5	0.035	-0.22	1.059	0.037	1.6	/
Back Upward	Body	39/2441.0	DH5	<b>0.095</b>	2.09	1.059	<b>0.101</b>	1.6	38



Note:

Per KDB Publication 941225 D01v03r01. RMC 12.2kbps was as primary mode SAR, when the primary mode SAR less than 1.2W/kg, secondary SAR (HSPA) was not requires.

When the 1-g SAR for the mid-band channel or the channel with the highest output power satisfy the following conditions, testing of the other channels in the band is not required. (Per KDB 447498 D01 General RF Exposure Guidance v06)

- $\leq 0.8$  W/kg, when the transmission band is  $\leq 100$  MHz
- $\leq 0.6$  W/kg, when the transmission band is between 100 MHz and 200 MHz
- $\leq 0.4$  W/kg, when the transmission band is  $\geq 200$  MHz



## 11. Simultaneous Transmissions Analysis

Localized Specific Absorption Rate (SAR) of this portable wireless device has been measured in all cases requested by the relevant standards cited in Clause 6 of this report. Maximum localized SAR is **below** exposure limits specified in the relevant standards.

### Simultaneous SAR

No.	Transmitter Combinations	Head	Body	Hotspot
1	WWAN + WLAN 2.4GHz	Support	Support	Support
2	WWAN + WLAN 5GHz	Support	Support	No
3	WWAN+ Bluetooth	Support	Support	No

Note:

1. EUT will choose each GSM, WCDMA, LTE according to the network signal condition; therefore, they will not operate simultaneously at any moment.
2. The reported SAR summation is calculated based on the same configuration and test position.



Simultaneous Tx Combination of GSM/WCDMA/LTE and BT/WIFI (Head)

Test Position/Freq.	Right Cheek	Right Tilted	Left Cheek	Left Tilted	
Head MAX 1-g SAR(W/Kg)	GSM 850 ANT 4	0.108	0.031	0.156	0.047
	GSM 1900 ANT 4	0.084	0.024	0.117	0.033
	WCDMA 850 ANT 4	0.079	0.024	0.120	0.036
	WCDMA 1900 ANT 4	0.116	0.035	0.162	0.046
	LTE Band 2 ANT 4	0.112	0.032	0.156	0.048
	LTE Band 4 ANT 4	0.149	0.042	0.208	0.053
	LTE Band 5 ANT 4	0.081	0.026	0.113	0.037
	LTE Band 7 ANT 4	0.052	0.018	0.077	0.026
	LTE Band 12 ANT 4	0.108	0.033	0.145	0.043
	LTE Band 13 ANT 4	0.080	0.023	0.107	0.034
	LTE Band 17 ANT 4	0.106	0.029	0.138	0.037
	LTE Band 38 ANT 4	0.034	0.015	0.047	0.022
	LTE Band 41 ANT 3	0.045	0.016	0.060	0.022
	WIFI 2.4G ANT 2	0.156	0.178	0.183	0.189
	WIFI 5G U-NII 1 ANT 2	0.251	0.272	0.314	0.330
	WIFI 5G U-NII 2a ANT 2	0.264	0.291	0.333	0.362
	WIFI 5G U-NII 2c ANT 2	0.286	0.325	0.368	0.381
WIFI 5G U-NII 3 ANT 2	0.275	0.305	0.332	0.350	
BT ANT 2	0.051	0.054	0.056	0.061	
WWAN MAX SAR	0.149	0.042	0.208	0.053	
WIFI/BT MAX SAR	0.286	0.325	0.368	0.381	
Max Simultaneous $\sum$ 1-g SAR(W/Kg) (WIFI/BT MAX SAR +WWAN ANT MAX SAR)	0.435	0.367	0.576	0.434	



Simultaneous Tx Combination of GSM/WCDMA/LTE and BT/WIFI (Body-worn).

Test Position		Front	Back	Left	Right	Top	Bottom
Body-worn MAX 1-g SAR(W/Kg) 10mm distance	GSM 850 ANT 4	0.115	0.242	/	/	/	/
	GSM 1900 ANT 4	0.310	0.735	/	/	/	/
	WCDMA 850 ANT 4	0.127	0.215	/	/	/	/
	WCDMA 1900 ANT 4	0.324	0.708	/	/	/	/
	LTE Band 2 ANT 4	0.351	0.727	/	/	/	/
	LTE Band 4 ANT 4	0.306	0.690	/	/	/	/
	LTE Band 5 ANT 4	0.141	0.225	/	/	/	/
	LTE Band 7 ANT 4	0.449	1.007	/	/	/	/
	LTE Band 12 ANT 4	0.145	0.339	/	/	/	/
	LTE Band 13 ANT 4	0.127	0.266	/	/	/	/
	LTE Band 17 ANT 4	0.132	0.324	/	/	/	/
	LTE Band 38 ANT 4	0.254	0.502	/	/	/	/
	LTE Band 41 ANT 3	0.223	0.548	/	/	/	/
	WIFI 2.4G ANT 2	0.177	0.372	/	/	/	/
	WIFI 5G U-NII 1 ANT 2	0.148	0.473	/	/	/	/
	WIFI 5G U-NII 2a ANT 2	0.166	0.507	/	/	/	/
WIFI 5G U-NII 2c ANT 2	0.150	0.468	/	/	/	/	
WIFI 5G U-NII 3 ANT 2	0.139	0.430	/	/	/	/	
BT ANT 2	0.037	0.101	/	/	/	/	
WWAN MAX SAR		0.449	1.007	/	/	/	/
WIFI/BT MAX SAR		0.177	0.507	/	/	/	/
Max Simultaneous $\sum$ 1-g SAR(W/Kg) (WIFI/BT MAX SAR +WWAN ANT MAX SAR)		0.626	1.514	/	/	/	/



Simultaneous Tx Combination of GSM/WCDMA/LTE and WIFI (Hotspot).

Test Position		Front	Back	Left	Right	Top	Bottom
Hotspot MAX 1-g SAR(W/Kg) 10mm distance	GSM 850 ANT 4	0.115	0.242	0.092	0.108	/	0.175
	GSM 1900 ANT 4	0.310	0.735	0.157	0.202	/	0.615
	WCDMA 850 ANT 4	0.127	0.215	0.102	0.088	/	0.148
	WCDMA 1900 ANT 4	0.324	0.708	0.138	0.206	/	0.593
	LTE Band 2 ANT 4	0.351	0.727	0.177	0.235	/	0.752
	LTE Band 4 ANT 4	0.306	0.690	0.149	0.191	/	0.720
	LTE Band 5 ANT 4	0.141	0.225	0.075	0.061	/	0.190
	LTE Band 7 ANT 4	0.449	1.007	0.235	0.198	/	0.513
	LTE Band 12 ANT 4	0.145	0.339	0.074	0.094	/	0.318
	LTE Band 13 ANT 4	0.127	0.266	0.091	0.074	/	0.245
	LTE Band 17 ANT 4	0.132	0.324	0.067	0.093	/	0.284
	LTE Band 38 ANT 4	0.254	0.502	0.129	0.103	/	0.231
	LTE Band 41 ANT 3	0.223	0.548	0.197	0.133	/	0.287
	WIFI 2.4G ANT 2	0.177	0.372	/	0.128	0.229	/
WWAN MAX SAR		0.449	1.007	0.235	0.235	/	0.752
WIFI/BT MAX SAR		0.177	0.372	/	0.128	0.229	/
Max Simultaneous $\sum$ 1-g SAR(W/Kg) (WIFI/BT MAX SAR +WWAN ANT MAX SAR)		0.626	1.379	0.235	0.363	0.229	0.752

**SAR to Peak Location Separation Ratio (SPLSR)**

As the Sum of the SAR is not greater than 1.6 W/kg SPLSR assessment is not required

## 12.Measurement Uncertainty

No.	Uncertainty Component	Type	Uncertainty Value (%)	Probability Distribution	k	ci	Standard Uncertainty (%) $u_i(\%)$	Degree of freedom $\nu_{eff}$ or $\nu_i$
<b>Measurement System</b>								
1	- Probe Calibration	B	5.8	N	1	1	5.8	$\infty$
2	- Axial isotropy	B	3.5	R	$\sqrt{3}$	0.5	1.43	$\infty$
3	- Hemispherical Isotropy	B	5.9	R	$\sqrt{3}$	0.5	2.41	$\infty$
4	- Boundary Effect	B	1	R	$\sqrt{3}$	1	0.58	$\infty$
5	- Linearity	B	4.7	R	$\sqrt{3}$	1	2.71	$\infty$
6	- System Detection Limits	B	1.0	R	$\sqrt{3}$	1	0.58	$\infty$
7	Modulation response	B	3	N	1	1	3.00	
8	- Readout Electronics	B	0.5	N	1	1	0.50	$\infty$
9	- Response Time	B	1.4	R	$\sqrt{3}$	1	0.81	$\infty$
10	- Integration Time	B	3.0	R	$\sqrt{3}$	1	1.73	$\infty$
11	- RF Ambient Conditions	B	3.0	R	$\sqrt{3}$	1	1.73	$\infty$
12	- Probe Position Mechanical tolerance	B	1.4	R	$\sqrt{3}$	1	0.81	$\infty$
13	- Probe Position with respect to Phantom Shell	B	1.4	R	$\sqrt{3}$	1	0.81	$\infty$
14	- Extrapolation, Interpolation and Integration Algorithms for Max. SAR evaluation	B	2.3	R	$\sqrt{3}$	1	1.33	$\infty$
<b>Uncertainties of the DUT</b>								



15	- Position of the DUT	A	2.6	N	$\sqrt{3}$	1	2.6	5
16	- Holder of the DUT	A	3	N	$\sqrt{3}$	1	3.0	5
17	- Output Power Variation – SAR drift measurement	B	5.0	R	$\sqrt{3}$	1	2.89	$\infty$
<b>Phantom and Tissue Parameters</b>								
18	- Phantom Uncertainty(shape and thickness tolerances)	B	4	R	$\sqrt{3}$	1	2.31	$\infty$
19	Uncertainty in SAR correction for deviation(in permittivity and conductivity)	B	2	N	1	1	2.00	
20	- Liquid Conductivity Target – tolerance	B	2.5	R	$\sqrt{3}$	0.6	1.95	$\infty$
21	- Liquid Conductivity – measurement Uncertainty)	B	4	N	$\sqrt{3}$	1	0.92	9
22	- Liquid Permittivity Target tolerance	B	2.5	R	$\sqrt{3}$	0.6	1.95	$\infty$
23	- Liquid Permittivity – measurement uncertainty	B	5	N	$\sqrt{3}$	1	1.15	$\infty$
<b>Combined Standard Uncertainty</b>				RSS			10.63	
<b>Expanded uncertainty</b> (Confidence interval of 95 %)				K=2			21.26	





### 13. System Check Uncertainty

No.	Uncertainty Component	Type	Uncertainty Value (%)	Probability Distribution	k	ci	Standard Uncertainty (%) $u_i(\%)$	Degree of freedom $v_{eff}$ or $v_i$
<b>Measurement System</b>								
1	- Probe Calibration	B	5.8	N	1	1	5.8	$\infty$
2	- Axial isotropy	B	3.5	R	$\sqrt{3}$	0.5	1.43	$\infty$
3	- Hemispherical Isotropy	B	5.9	R	$\sqrt{3}$	0.5	2.41	$\infty$
4	- Boundary Effect	B	1	R	$\sqrt{3}$	1	0.58	$\infty$
5	- Linearity	B	4.7	R	$\sqrt{3}$	1	2.71	$\infty$
6	- System Detection Limits	B	1	R	$\sqrt{3}$	1	0.58	$\infty$
7	Modulation response	B	0	N	1	1	0.00	
8	- Readout Electronics	B	0.5	N	1	1	0.50	$\infty$
9	- Response Time	B	0.00	R	$\sqrt{3}$	1	0.00	$\infty$
10	- Integration Time	B	1.4	R	$\sqrt{3}$	1	0.81	$\infty$
11	- RF Ambient Conditions	B	3.0	R	$\sqrt{3}$	1	1.73	$\infty$
12	- Probe Position Mechanical tolerance	B	1.4	R	$\sqrt{3}$	1	0.81	$\infty$
13	- Probe Position with respect to Phantom Shell	B	1.4	R	$\sqrt{3}$	1	0.81	$\infty$
14	- Extrapolation, Interpolation and Integration Algorithms for Max. SAR evaluation	B	2.3	R	$\sqrt{3}$	1	1.33	$\infty$
<b>Uncertainties of the DUT</b>								



15	Deviation of experimental source from numerical source	A	4	N	1	1	4.00	5
16	Input Power and SAR drift measurement	A	5	R	$\sqrt{3}$	1	2.89	5
17	Dipole Axis to Liquid Distance	B	2	R	$\sqrt{3}$	1	1.2	$\infty$
<b>Phantom and Tissue Parameters</b>								
18	- Phantom Uncertainty(shape and thickness tolerances)	B	4	R	$\sqrt{3}$	1	2.31	$\infty$
19	Uncertainty in SAR correction for deviation(in permittivity and conductivity)	B	2	N	1	1	2.00	
20	- Liquid Conductivity Target – tolerance	B	2.5	R	$\sqrt{3}$	0.6	1.95	$\infty$
21	- Liquid Conductivity – measurement Uncertainty)	B	4	N	$\sqrt{3}$	1	0.92	9
22	- Liquid Permittivity Target tolerance	B	2.5	R	$\sqrt{3}$	0.6	1.95	$\infty$
23	- Liquid Permittivity – measurement uncertainty	B	5	N	$\sqrt{3}$	1	1.15	$\infty$
<b>Combined Standard Uncertainty</b>				RSS			10.15	
<b>Expanded uncertainty</b> (Confidence interval of 95 %)				K=2			20.29	



## 14. Equipment List

This table is a complete overview of the SAR measurement equipment. Devices used during the test described are marked .

	EQUIPMENT	Model	Serial number	Calibration Date	Due Date
<input checked="" type="checkbox"/>	SAR Probe	SSE2	0523-EPGO-403	2023/02/14	2024/02/13
<input checked="" type="checkbox"/>	Dipole	SID750	SN 23/15 DIP0G750-378	2023/05/24	2026/05/23
<input checked="" type="checkbox"/>	Dipole	SID835	SN 09/13 DIP0G835-217	2023/05/24	2026/05/23
<input checked="" type="checkbox"/>	Dipole	SID1800	SN 09/13 DIP1G800-216	2023/05/24	2026/05/23
<input checked="" type="checkbox"/>	Dipole	SID1900	SN 09/13 DIP1G900-218	2023/05/24	2026/05/23
<input checked="" type="checkbox"/>	Dipole	SID2450	SN 09/13 DIP2G450-220	2023/05/24	2026/05/23
<input checked="" type="checkbox"/>	Dipole	SID2600	SN 32/14 DIP2G600-338	2023/05/24	2026/05/23
<input checked="" type="checkbox"/>	Dipole	SWG5500	SN15/15 WGA39	2023/05/25	2026/05/24
<input checked="" type="checkbox"/>	Multimeter	Keithley-2000	4014020	2023/02/20	2024/02/19
<input checked="" type="checkbox"/>	System Simulator(R&S)	CMW500	130805	2023/07/13	2024/07/12
<input checked="" type="checkbox"/>	KEYSIGHT	E7515A	MY56040357	2023/02/20	2024/02/19
<input checked="" type="checkbox"/>	Vector Network Analyzer(R&S)	ZVB8	100343	2023/02/20	2024/02/19
<input checked="" type="checkbox"/>	PC 3.5 Fixed Match Calibration Kit	ZV-Z32	100571	2023/02/20	2024/02/19
<input checked="" type="checkbox"/>	Dielectric Probe Kit	SCLMP	SN 09/13 OCPG51	2023/02/20	2024/02/19
<input checked="" type="checkbox"/>	Signal Generator	SMU100A	177649	2023/02/20	2024/02/19
<input checked="" type="checkbox"/>	Amplifier	Nucletudes	143060	2023/02/20	2024/02/19
<input checked="" type="checkbox"/>	Directional Coupler	DC6180A	305827	2023/06/15	2024/06/14
<input checked="" type="checkbox"/>	Power Meter	NRP2	103434	2023/02/20	2024/02/19



## ANNEX A: Appendix A: SAR System performance Check Plots

(Please See Appendix A)

## ANNEX B: Appendix B: SAR Measurement results Plots

(Please See Appendix B)

## ANNEX C: Appendix C: Calibration reports

(Please See Appendix C)

## ANNEX D: Appendix D: SAR Test Setup

(Please See Appendix D)

—End of the Report—