

Z-Wave Roller Shutter Controller

User's Manual

Introduction

Z-Wave Roller Shutter Controller is an ideal for the remotely electric motor controller. It is used to control the motors of rollers, shades, blinds, venetian blinds and similar sun shade, which are single phase AC powered. The module can be controlled either through a Z-Wave network or through the wall switch, and measures power consumption of motor.

Z-Wave Roller Shutter needs to motor calibration before use, please refer to CONFIGURATION command class parameter 0x01. Z-Wave Roller Shutter's positioning calibration does not apply to motor without obstacle detection, using this function may cause unpredictable problems, please make sure your motor has obstacle detection function before positioning calibration.

Package Contents

- Z-Wave Roller Shutter Controller x1
- User Manual x1

Command Class

Device Information

GENERIC_TYPE_SWITCH_MULTILEVEL
SPECIFIC_TYPE_CLASS_C_MOTOR_CONTROL

z-wave protocol Command Class Node Info

- COMMAND_CLASS_ZWAVEPLUS_INFO_V2
- COMMAND_CLASS_VERSION_V3
- COMMAND_CLASS_MANUFACTURER_SPECIFIC_V2
- COMMAND_CLASS_DEVICE_RESET_LOCALLY_V1
- COMMAND_CLASS_POWERLEVEL_V1
- COMMAND_CLASS_SWITCH_MULTILEVEL_V3
- COMMAND_CLASS_CONFIGURATION_V1
- COMMAND_CLASS_ASSOCIATION_V2
- COMMAND_CLASS_ASSOCIATION_GRP_INFO_V1
- COMMAND_CLASS_SWITCH_BINARY_V1
- COMMAND_CLASS_METER_V3
- COMMAND_CLASS_FIRMWARE_UPDATE_MD_V4
- COMMAND_CLASS_SUPERVISION_V1
- COMMAND_CLASS_Transport_Service_V2
- COMMAND_CLASS_SECURITY_V1
- COMMAND_CLASS_SECURITY_2_V1

The Below listed Command Class are all supported the Security S2

- COMMAND_CLASS_VERSION_V3
- COMMAND_CLASS_MANUFACTURER_SPECIFIC_V2
- COMMAND_CLASS_DEVICE_RESET_LOCALLY_V1
- COMMAND_CLASS_POWERLEVEL_V1
- COMMAND_CLASS_SWITCH_MULTILEVEL_V3
- COMMAND_CLASS_CONFIGURATION_V1
- COMMAND_CLASS_ASSOCIATION_V2
- COMMAND_CLASS_ASSOCIATION_GRP_INFO_V1
- COMMAND_CLASS_SWITCH_BINARY_V1
- COMMAND_CLASS_METER_V3
- COMMAND_CLASS_FIRMWARE_UPDATE_MD_V4
- COMMAND_CLASS_SUPERVISION_V1

Detailed description of each command class

【ZWAVEPLUS INFO command class】

The Z-Wave Plus Info Get Command is used to get additional information of the Z-Wave Plus device in question.

【VERSION command class】

The user can enquire the version of the unit using VERSION_GET command. It will return VERSION_REPORT Command. Version Report Command:

[Command Class Version, Version Report, Z-Wave Library Type, Z-Wave Protocol Version, Z-Wave Protocol Sub Version, Application Version, Application Sub Version]

【MANUFACTURER SPECIFIC command class】

The user can use the Manufacturer Specific Get Command to request manufacturer specific information from another node. Manufacturer Specific Report Command:

[Command Class Manufacturer Specific, Manufacturer ID 1, Manufacturer ID 2, Product Type ID 1, Product Type ID 2, Product ID 1, Product ID 2]

【DEVICE RESET LOCALLY command class】

The Device Reset Locally Command Class is used to notify central controllers that a Z-Wave device is resetting its network specific parameters.

【POWERLEVEL command class】

The Power level Command Class defines RF transmit power controlling commands useful when installing or testing a network. The commands make it possible for supporting controllers to set/get the RF transmit power level of a node and test specific links between nodes with a specific RF transmit power level.

【BASIC command class】

Control the roller shutter to be opened or closed after receiving the BASIC_SET command.

To be opened:

[Command Class Multilevel, Multilevel Set, Value = 0xFF]

To be closed:

[Command Class Multilevel, Multilevel Set, Value= 0x00]

To be the percentage of full opened position:

[Command Class Multilevel, Multilevel Set, Value = 0x01~0x63]

【SWITCH MULTILEVEL command class】

Control the roller shutter to be opened, closed, stopped or be the percentage of full opened position after receiving the SWITCH_MULTILEVEL command.

To be opened:

[Command Class Multilevel, Multilevel Set, Value = 0xFF]

To be closed:

[Command Class Multilevel, Multilevel Set, Value= 0x00]

To be the percentage of full opened position:

[Command Class Multilevel, Multilevel Set, Value = 0x01~0x63]

To be stopped:

[Command Class Multilevel, SWITCH_MULTILEVEL_STOP_LEVEL_CHANGE]

【CONFIGURATION command class】

This class is used for setting certain vendor specific configuration variables. See the following table for configuration variables:

Parameter	Name	Size (byte)	Range	Default value	Description
1 (0x01)	Positioning Calibration	1	0 - 1	0	0: Disable 1: Executing calibration
2 (0x02)	External switch Protection	1	0 - 1	0	0: Enable external switch 1: Disable external switch
3 (0x03)	When the door is opened, set the delay time for automatic closing.	2	0 - 32767	0	0: Disable automatic closing 1 - 32767: The door will be closed automatically in 1 - 32767sec
4 (0x04)	When the door is open, set the delay time for automatic notification.	2	0 - 32767	0	0: Disable automatic notification 1 - 32767: The notification will be sent automatically in 1 - 32767sec
5 (0x05)	Set the operation mode	1	0 - 1	0	0: Roller Shutter 1: Venetian (up/down and slate rotation)
6 (0x06)	Set the angle of blinds	1	0 - 6	0	Angles of blinds 0 : 0° 1 : 30° 2 : 60° 3 : 90° 4 : 120° 5 : 150° 6 : 180°
7 (0x07)	Set the slats turning time	1	0 - 127	15 (1.5sec)	0 : Disable. 1 - 127: 0.1 - 12.7 sec
8 (0x08)	Set the delay time to start the motor up to the blade	1	0 - 127	0	0 : No offset time 1 - 127: 0.1 - 12.7 sec
9 (0x09)	Set the delay time to start the motor down to the blade	1	0 - 127	0	0 : No offset time 1 - 127: 0.1 - 12.7 sec
10	Set the	1	0 - 100	0	0 : Disabled

(0x0A)	power changed percentage to send the power report				1 - 100: 1% - 100%
11 (0x0B)	Set the time interval of reporting watts in seconds	2	0, 60 - 32767	300 sec	0 : Disable 60 - 32767: 60 - 32767sec
12 (0x0C)	Set the time interval of reporting KWH in seconds	2	0, 60 - 32767	3600	0 : Disable 60 - 32767: 60 - 32767sec

【ASSOCIATION command class】

The device can be set 1 auto-report ID in Group 1.

The device sends an unsolicited command to the configured destinations when triggered by an event.

Group1:"Lifeline" :

【ASSOCIATION GRP INFO command class】

The purpose of the Association Group Information (AGI) Command Class is to allow a device to report the capabilities of each association group supported by the device.

【SWITCH_BINARY command class】

Control the roller shutter to be opened or closed after receiving the SWITCH_BINARY command.

To be opened:

[Command Class SWITCH_BINARY, Set Value = 0xFF]

To be closed:

[Command Class SWITCH_BINARY, Set Value = 0x00]

【METER command class】

The Meter Command Class is intended for Z-Wave enabled devices capable of reporting energy measurements in addition to any main functionality or features e.g. an appliance module reporting the current consumption of the connected load. The Meter command class not support V1&V2 version. And it will take about 3 seconds to show the meter report on the request sending device.

【FIRMWARE UPDATE META DATA command class】

Support OTA (On-The-Air) firmware update function.

【COMMAND_CLASS_SECURITY_V1】

【COMMAND_CLASS_SECURITY_2_V1】

This device is a security enabled Z-Wave Plus product that is able to use encrypted Z-Wave Plus messages to communicate to other security enabled Z-Wave Plus products.

Product Overview

Product Dimensions

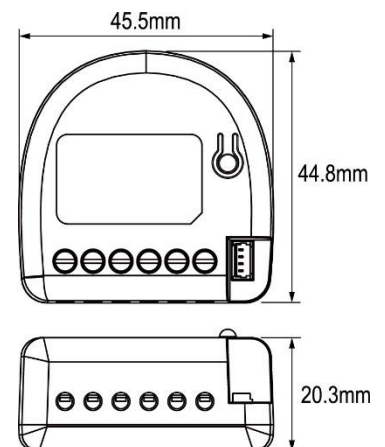

Application Diagram

Main Diagram

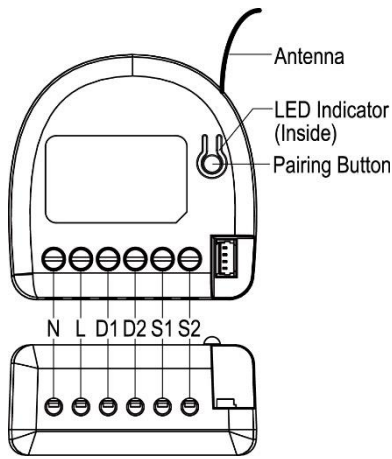

- Notes for the Diagram

N	Neutral lead
L	Live lead
D1	Output for motor UP
D2	Output for motor DOWN
S1	Input for switch/push button UP
S2	Input for switch/push button DOWN
Pairing Button	Include/ Exclude/ Reset Button

Device Installation

- Before installation make sure the voltage supply is disconnected.
- Put the device into a small box (such as wall box or small plastic box and etc.) near the motor to avoid direct exposure danger in the air and to the water.



- Connect the motor of Roller Shutter and Switch in accordance with the wiring diagram presented on Fig. 1 (roller blinds, venetian blinds).

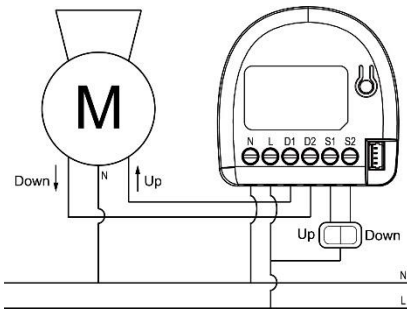

Figure 1. Roller Shutter wiring diagram

- Locate the antenna far from metal elements (as far as possible)
- Do not shorten the antenna.
- Turn on the power supply keeping the necessary safety precautions.
- Include the module into the Z-Wave network, please refer to the "Operation" section for "Inclusion" operating instructions.
- Executing the positioning calibration process, please refer to the "Operation" section for "Positioning calibration" operating instructions.

CAUTION!

- Read this manual before attempting to install the device! Failure to observe recommendations included in this manual may be dangerous or cause a violation of the law. The manufacturer will not be held responsible for any loss or damage resulting from not following the instructions of operating manual.
- Any maintenance work on controlled devices may be performed only after the power supply has been disconnected.
- Do not connect the module to loads exceeding recommended values. Connect the module only in accordance with the diagram presented in the manual. Improper connections may be dangerous.

Operation

Function	Operation
Add for Inclusion	<ol style="list-style-type: none"> Put the Z-Wave Controller into inclusion mode, and press the pairing button 3 times in 2 seconds to include the module. Put the Z-Wave Controller into inclusion mode, and press the "external switch1" or "external switch2" 3 times in 2 seconds to include the module.
Remove for Exclusion	<ol style="list-style-type: none"> Put the Z-Wave Controller into exclusion mode, and press the pairing button 3 times in 2 seconds to exclude the device. Put the Z-Wave Controller into inclusion mode, and press the "external switch1" or "external switch2" 3 times in 2 seconds to include the module.
Reset	<ol style="list-style-type: none"> Press the pairing button 3 times in 2 seconds and press and hold the pairing button for more than 5 seconds at the 3rd time. The module is excluded and restores to factory default setting. Then the module will be in auto-inclusion mode for 2 minutes. <p>Please use this procedure only when the network primary controller is missing or otherwise inoperable.</p>
Positioning calibration	<p>Positioning calibration is a process during which a Roller Shutter learns the position of the limit switches and a motor characteristic. Calibration is mandatory in order for the Roller Shutter to correctly recognize a roller blind position. The procedure consists of an automatic, full movement between the limit switches (up, down, and up again).</p> <p>There are three kinds of positioning calibration operation as follows:</p> <ol style="list-style-type: none"> Parameter Setting: Parameter 1(0x01), Size 1(byte), Value 1. Pairing Button: Press and hold the button for 6 to 10 seconds, release the button (less than 2 seconds), and then click the button (less than 2 seconds) External Switch: Use the same external switch (S1 or S2), turn on and off 3 times. Turn ON => OFF => ON => OFF => ON => OFF (Turn ON: lasts 3 to 10 seconds), Turn OFF: less than 2 seconds) <p>Note: If an emergency is encountered during the positioning calibration process, please click the external switch, the pairing button, or the APP to abort the positioning calibration processes.</p>

Notice: Including a node ID allocated by Z-Wave™ Controller means "Add" or "Inclusion". Excluding a node ID allocated by Z-Wave™ Controller means "Remove" or "Exclusion".

LED Indicator

LED Signal	Status
LED OFF	Power OFF
Red & Green blinking by turns	Power ON (No node ID)
Solid Green	Power ON (Included)
Green blinking twice per second for 3 seconds	<ol style="list-style-type: none"> Inclusion process success Exclusion process success Parameter setting success Positioning calibration success
Red blinking twice per second for 3 seconds	<ol style="list-style-type: none"> Inclusion process failed Exclusion process failed Parameter setting failed Positioning calibration failed
Green blinking twice per second for 2 minutes	Auto Inclusion Mode
Red blinking twice per second	Overload Protection

Specification

Wireless Type	Z-Wave Plus
Frequency	EU: 868.4 MHz US: 916.0 MHz
Operating Distance	up to 100m outdoors ; up to 30m indoors
Power Supply	110 - 230 VAC ±10% 50 / 60 Hz
Rated load current of AC output (resistive load)	2 @ 5A (230 VAC)
Rated power of Motor	Motor under 170W
Power measurement accuracy	P = 0-40 W, ± 2 W; P > 40 W, ±3%
Electricity Consumption	<0.5W

LED	Red /Green LED*1
Switching	Relay x 2
Data Rate	100 kbps
Operation temperature	-10°C ~ 40°C
Dimensions (L x W x H)	45.5 x 44.8 x 20.3 mm

*Specification is subject to change without prior notice.

External Switch Operation

S1	S2	Motor Action
Turn OFF	Turn OFF	STOP
Turn ON	Turn OFF	UP
Turn OFF	Turn ON	DOWN
Turn ON	Turn ON	STOP

Regulatory Compliance

CE Caution

Electromagnetic compatibility and Radio spectrum Matters (ERM); Short Range Devices (SRD); Radio equipment to be used in the 25 MHz to 1,000 MHz frequency range with power levels ranging up to 500 mW; Part 2: Harmonized EN covering essential requirements under article 3.2 of the R&TTE Directive.

FCC Caution

This device complies with Part 15 of the FCC rules standard. Operation is subject to the following two conditions:

- This device may not cause harmful interference, and
- This device must accept any interference received, including interference that may cause undesired operation.

Any changes or modifications not expressly approved by the party responsible for compliance could void the authority to operate equipment. This device and its antenna must not be co-located or operating in conjunction with any other antenna or transmitter. This equipment complies with FCC radiation exposure limits set forth for an uncontrolled environment. This equipment should be installed and operated with minimum distance 20cm between the radiator & your body. This equipment has been tested and found to comply with the limits for a Class B digital device, pursuant to part 15 of the FCC Rules. These limits are designed to provide reasonable protection against harmful interference in a residential installation. This equipment generates, uses and can radiate radio frequency energy and, if not installed and used in accordance with the instructions, may cause harmful interference to radio communications. However, there is no guarantee that interference will not occur in a particular installation. If this equipment does cause harmful interference to radio or television reception, which can be determined by turning the equipment off and on, the user is encouraged to try to correct the interference by one or more of the following measures:

- Reorient or relocate the receiving antenna.
- Increase the separation between the equipment and receiver.
- Connect the equipment into an outlet on a circuit different from that to which the receiver is connected.
- Consult the dealer or an experienced radio/TV technician for help.

WEEE Information

For EU (European Union) member users: According to the WEEE (Waste electrical and electronic equipment) Directive, do not dispose of this product as household waste or commercial waste. Waste electrical and electronic equipment should be appropriately collected and recycled as required by practices established for your country.

For information on recycling of this product, please contact your local authorities, your household waste disposal service or the shop where you purchased the product.

Z-Wave Plus

This product can be included and operated in any Z-Wave network with other Z-Wave certified devices from other manufacturers and/or other applications. All non-battery operated nodes within the network will act as repeaters regardless of vendor to increase reliability of the network.

This device must be used in conjunction with a Security Enabled Z-Wave Controller in order to fully utilize all implemented functions.

Security S2

Security S2 is supported with the Authenticated and UnAuthenticated levels of security. The Authenticated level requires the user to enter the PIN code or QR code printed on the box of the Roller Shutter. The UnAuthenticated level does not require the PIN code. Both security levels will encrypt nearly all communication using AES-128 encryption to ensure reliable and secure communication.

SmartStart

Sigma Designs technology makes installation easy and secure. Simply install Roller Shutter into a wall and it will automatically attempt to join the Z-Wave network. During the inclusion process, your home automation system will ask for a PIN code or to scan a QR code. The pin code is printed on the back of Roller Shutter along with the QR code. Simply enter the PIN code or scan the QR code with a compatible device. Each QR code is unique for every device. SmartStart uses the latest Security S2 encryption technology for all radio communication. It is completely backwards compatible with non-SmartStart systems if your home automation system doesn't

support it yet.

Ex:



WARNING: Important safety instructions.

It is important for the safety of persons to follow these instructions.

Save these instructions.

- Important safety instructions. Follow all instructions, since incorrect installation can lead to severe injury
- All wiring interconnecting with this controller is non-isolated hazardous live parts.
- The appliance is not to be used by persons (including children) with reduced physical, sensory or mental capabilities, or lack of experience and knowledge, unless they have been given supervision or instruction.
- Frequently examine the installation for imbalance and signs of wear or damage to cables and springs.
- Do not use if repair or adjustment is necessary.
- Do not allow children to play with fixed controls. Keep remote controls away from children.
- The drive shall be disconnected from its power source during cleaning, maintenance and when replacing parts.
- Indoor use only.
- Never install independent switch for each S1 and S2, to prevent the activation on D1 and D2 at the same time.
- Material used only for the 16 AWG copper wires and the suggested strip length is 4.5 ~ 5 mm.
- Equipment shall not be interconnected with the output of another power source.
- High Voltage - Disconnect power supply before servicing.
- Risk of Electric Shock - More than one disconnect switch may be required to de-energize the device before servicing.