



FCC TEST REPORT

According to

FCC Rules and Regulations Part 15 Subpart C

Applicant : Good Way Technology Co., Ltd.
Address : 3F, No. 135, Lane 235, Pau Chiao Rd.,
Hsin-Tien City, 231 Taipei Hsien, Taiwan
Equipment : 4 Port Wireless USB Server
Model No. : FW2140
FCC ID. : SW8FW2140
Trade Name : GOOD WAY

- The test result refers exclusively to the test presented test model / sample.,
- Without written approval of **CerpPASS Technology Corp.**, the test report shall not be reproduced except in full.
- The EUT is also considered as a kind of computer peripheral, because the connection to computer is necessary for typical use. It has been verified to comply with the requirements of FCC Part 15, Subpart B, Class B (DoC). The test report has been issued separately.



Contents

| | |
|--|-----------|
| 1. Report of Measurements and Examinations | 6 |
| 1.1 List of Measurements and Examinations | 6 |
| 2. Test Configuration of Equipment under Test | 7 |
| 2.1 Feature of Equipment under Test | 7 |
| 2.2 RF Specifications | 7 |
| 2.3 Carrier Frequency of Channels | 8 |
| 2.4 Test Mode and Test Software | 8 |
| 2.5 Description of Test System | 9 |
| 2.6 General Information of Test | 10 |
| 2.7 Measurement Uncertainty | 10 |
| 3. Antenna Requirements | 11 |
| 3.1 Standard Applicable | 11 |
| 3.2 Antenna Construction and Directional Gain | 11 |
| 4. Test of Conducted Emission | 12 |
| 4.1 Test Limit | 12 |
| 4.2 Test Procedures | 12 |
| 4.3 Typical Test Setup | 13 |
| 4.4 Measurement Equipment | 13 |
| 4.5 Test Result and Data | 14 |
| 4.6 Test Photographs | 20 |
| 5. Test of Radiated Emission | 21 |
| 5.1 Test Limit | 21 |
| 5.2 Test Procedures | 21 |
| 5.3 Typical Test Setup | 22 |
| 5.4 Measurement Equipment | 22 |
| 5.5 Test Result and Data | 23 |
| 5.6 Test Photographs | 59 |
| 6. 6dB Bandwidth Measurement Data | 60 |
| 6.1 Test Limit | 60 |
| 6.2 Test Procedures | 60 |
| 6.3 Test Setup Layout | 60 |
| 6.4 Measurement Equipment | 60 |
| 6.5 Test Result and Data | 60 |
| 7. Maximum Peak Output Power | 67 |
| 7.1 Test Limit | 67 |
| 7.2 Test Procedures | 67 |
| 7.3 Test Setup Layout | 67 |
| 7.4 Measurement Equipment | 67 |
| 7.5 Test Result and Data | 68 |
| 8. Power Spectral Density | 75 |
| 8.1 Test Limit | 75 |
| 8.2 Test Procedures | 75 |
| 8.3 Test Setup Layout | 75 |



8.4 Measurement Equipment..... 75

8.5 Test Result and Data..... 75

9. Band Edges Measurement..... 82

9.1 Test Limit 82

9.2 Test Procedure 82

9.3 Test Setup Layout 82

9.4 Measurement Equipment..... 82

9.5 Test Result and Data..... 82

9.6 Restrict Band Emission Measurement Data 91

10. Restricted Bands of Operation..... 93

10.1 Labeling Requirement..... 93

Appendix A. Photographs of EUT.....A1 ~ A7



History of this test report

■ ORIGINAL.

Additional attachment as following record:

| Attachment No. | Issue Date | Description |
|----------------|------------|-------------|
| | | |
| | | |
| | | |
| | | |
| | | |
| | | |
| | | |
| | | |
| | | |
| | | |
| | | |
| | | |
| | | |
| | | |
| | | |
| | | |
| | | |
| | | |
| | | |
| | | |



CERTIFICATE OF COMPLIANCE

According to

FCC Rules and Regulations Part 15 Subpart C

Applicant : Good Way Technology Co., Ltd.
Address : 3F, No. 135, Lane 235, Pau Chiao Rd.,
Hsin-Tien City, 231 Taipei Hsien, Taiwan
Equipment : 4 Port Wireless USB Server
Model No. : FW2140
FCC ID. : SW8FW2140

I **HEREBY** CERTIFY THAT :

The measurements shown in this test report were made in accordance with the procedures given in **ANSI C63.4** The equipment was **passed** the test performed according to **FCC Rules and Regulations Part 15 Subpart C (2010)**.

The test was carried out on Sep. 22, 2011 at CerpPASS Technology Corp.

Signature

Clark Lin
EMC/RF B.U. Deputy Manager



1. Report of Measurements and Examinations

1.1 List of Measurements and Examinations

| FCC Rule | Description of Test | Result |
|--------------------------------------|--|--------|
| 15.203 | . Antenna Requirement | Pass |
| 15.207 | . Conducted Emission | Pass |
| 15.209 15.247(d) | . Radiated Emission | Pass |
| 15.247(a)(2) | . 6dB Bandwidth | Pass |
| 15.247(b) | . Maximum Peak Output Power | Pass |
| 15.247(d) | . 100kHz Bandwidth of Frequency Band Edges | Pass |
| 15.247(e) | . Power Spectral Density | Pass |
| 1.1307 1.1310 2.1091 2.1093 | . RF Exposure Compliance | Pass |



2. Test Configuration of Equipment under Test

2.1 Feature of Equipment under Test

| Item | Description |
|-----------------------|--------------------|
| Ports | 4xUSB 2.0 |
| Connector | USB-A female |
| ESD protect | 8 KV ESD |
| Transmission Speed | 12M~480Mbps |
| Interface | GigaLAN / Wi-Fi |
| Interface connector | RJ-45 / Antenna |
| Power requirements | 5V3A DC / 9~36 VDC |
| Operating temperature | 0~55°C |
| Operating humidity | 5~95% RH |

2.2 RF Specifications

| | |
|--------------------|--|
| Spreading | 802.11b: DSSS, CCK, QPSK, BPSK 802.11g: OFDM (64QAM, 16QAM, QPSK, BPSK) 802.11n, HT20: OFDM (64QAM, 16QAM, QPSK, BPSK) 802.11n, HT40: OFDM (64QAM, 16QAM, QPSK, BPSK) |
| Frequency Range | 2.4 ~ 2.4835 GHz |
| Number of Channels | USA, Canada and Taiwan: 1 ~ 11 Most European Countries: 1 ~ 13 |
| Data Rate | 802.11b: 11, 5.5, 2, 1 Mbps 802.11g: 54, 48, 36, 24, 18, 12, 9, 6 Mbps 802.11n HT20: 130/15, 117/14, 104/13, 78/12, 52/11, 39/10, 26/9, 13/8, 65/7, 58.5/6, 52/5, 39/4, 26/3, 19.5/2, 13/1, 6.5/0Mbps 802.11 n HT40: 270/15, 243/14, 216/13, 162/12, 108/11, 81/10, 54/9, 27/8, 135/7, 121.5/6, 108/5, 81/4, 54/3, 40.5/2, 27/1, 13.5/0Mbps |
| Modulation | 802.11b: DSSS, CCK, QPSK, BPSK 802.11g: OFDM (64QAM, 16QAM, QPSK, BPSK) 802.11n, HT20: OFDM (64QAM, 16QAM, QPSK, BPSK) 802.11n, HT40: OFDM (64QAM, 16QAM, QPSK, BPSK) |
| Antenna Type | Dipole Antenna |
| Antenna Gain | 2dBi |
| Transmit Power | FCC: 802.11b: 17.68 dBm / 802.11g: 15.38 dBm / 802.11n: 15.39 dBm ETSI: (EIRP): 802.11b: 17.44 dBm / 802.11g: 15.34 dBm / 802.11n: 15.58 dBm |



2.3 Carrier Frequency of Channels

802.11b, 802.11g, 802.11n HT 20

| Channel | Frequency(MHz) | Channel | Frequency(MHz) |
|---------|----------------|---------|----------------|
| 01 | 2412 | 07 | 2442 |
| 02 | 2417 | 08 | 2447 |
| 03 | 2422 | 09 | 2452 |
| 04 | 2427 | 10 | 2457 |
| 05 | 2432 | 11 | 2462 |
| 06 | 2437 | --- | --- |

802.11n HT40

| Channel | Frequency(MHz) | Channel | Frequency(MHz) |
|---------|----------------|---------|----------------|
| --- | --- | 07 | 2442 |
| --- | --- | 08 | 2447 |
| 03 | 2422 | 09 | 2452 |
| 04 | 2427 | --- | --- |
| 05 | 2432 | --- | --- |
| 06 | 2437 | --- | --- |

2.4 Test Mode and Test Software

- a. During testing, the interface cables and equipment positions were varied according to ANSI C63.4.
- b. The complete test system included the Remote Workstation, Flash Memory and EUT for RF test. The Remote workstation includes Notebook.
- c. An executive program, "Ralink wireless Utility" under WIN XP was executed to transmit and receive data to through Wireless.
- d. The following test modes were performed for test:
 - 802.11b/g/n HT20: CH01: 2412MHz, CH06: 2437MHz, CH11: 2462MHz
 - 802.11n HT40: CH03: 2422MHz, CH06: 2437MHz, CH09: 2452MHz
- e. The following data rates were the worst cases of power output and be performed for test:
 - 802.11b: 11Mbps
 - 802.11g: 54Mbps
 - 802.11n HT20: 130Mbps
 - 802.11n HT40: 270Mbps

* Power output of data rate:

| 802.11b | | 802.11g | |
|------------------|--------------------|------------------|--------------------|
| Data Rate (Mbps) | Power output (dBm) | Data Rate (Mbps) | Power output (dBm) |
| 11 | 17.68 | 54 | 15.38 |
| 5.5 | 17.49 | 48 | 15.32 |
| 2 | 17.26 | 36 | 15.25 |
| 1 | 17.21 | 24 | 15.22 |
| | | 18 | 15.26 |
| | | 12 | 15.30 |
| | | 9 | 15.28 |
| | | 6 | 15.25 |



| 802.11n HT20 | | 802.11n HT40 | |
|------------------|--------------------|------------------|--------------------|
| Data Rate (Mbps) | Power output (dBm) | Data Rate (Mbps) | Power output (dBm) |
| 130/15 | 15.39 | 270/15 | 15.35 |
| 117/14 | 15.31 | 243/14 | 15.30 |
| 104/13 | 15.28 | 216/13 | 15.29 |
| 78/12 | 15.24 | 162/12 | 15.25 |
| 52/11 | 15.26 | 108/11 | 15.26 |
| 39/10 | 15.25 | 81/10 | 15.23 |
| 26/9 | 15.23 | 54/9 | 15.28 |
| 13/8 | 15.21 | 27/8 | 15.25 |
| 65/7 | 15.25 | 135/7 | 15.22 |
| 58.5/6 | 15.20 | 121.5/6 | 15.21 |
| 52/5 | 15.29 | 108/5 | 15.26 |
| 39/4 | 15.22 | 81/4 | 15.21 |
| 26/3 | 15.21 | 54/3 | 15.26 |
| 19.5/2 | 15.25 | 40.5/2 | 15.22 |
| 13/1 | 15.31 | 27/1 | 15.32 |
| 6.5/0 | 15.32 | 13.5/0 | 15.32 |

2.5 Description of Test System

| Device | Manufacturer | Model No. | Description |
|--------------------|--------------|-----------|--------------------------------|
| Flash Memory*4 | N/A | N/A | N/A |
| Remote Workstation | | | |
| Notebook | SONY | VPCEB25FW | Power Cable, Unshielding 1.8 m |

Use Cable:

| Cable | Quantity | Description |
|-------|----------|------------------|
| RJ45 | 1 | Unshielding, 15m |



2.6 General Information of Test

| | |
|------------------------------------|---|
| Test Site : | CerpPASS Technology Corp. 2F-11, No. 3, Yuan Qu St., (Nankang Software Park), Taipei, Taiwan 115, R.O.C. |
| Test Site Location (OATS2-SD) : | No.68-1, Shihbachongsi, Shihding Township, Taipei City 223, Taiwan, R.O.C. |
| FCC Registration Number : | TW1049, TW1061, 488071, 390316 |
| IC Registration Number : | 4934B-1, 4934D-1 |
| VCCI Registration Number : | T-543 for Telecommunication Test C-3328 for Conducted emission test R-3013 for Radiated emission test G-97 for radiated disturbance above 1GHz |
| Test in Compliance with: | ANSI C63.4-2009 FCC Part 15 Subpart C |
| Frequency Range Investigated: | Conducted: from 150kHz to 30MHz Radiation: from 30MHz to 25,000MHz |
| Test Distance: | The test distance of radiated emission from antenna to EUT is 3 M. |

2.7 Measurement Uncertainty

| Measurement Item | Measurement Frequency | Polarization | Uncertainty |
|---|------------------------|----------------|-------------|
| Conducted Emission | 9 kHz ~ 30 MHz | LINE / NEUTRAL | 2.71 dB |
| Radiated Emission | 30 MHz ~ 1,000 MHz | Vertical | 3.52 dB |
| | | Horizontal | 3.39 dB |
| | 1,000 MHz ~ 18,000 MHz | Vertical | 4.39 dB |
| | | Horizontal | 5.25 dB |
| 6 dB Bandwidth | --- | --- | 7500 Hz |
| Maximum Peak Output Power | --- | --- | 1.4 dB |
| 100kHz Bandwidth of Frequency Band Edges | --- | --- | 2.2 dB |
| Power Spectral Density | --- | --- | 2.2 dB |



3. Antenna Requirements

3.1 Standard Applicable

For intentional device, according to FCC 47 CFR Section 15.203, an intentional radiator shall be designed to ensure that no antenna other than that furnished by the responsible party shall be used with the device.

And according to FCC 47 CFR Section 15.247 (b), if transmitting antennas of directional gain greater than 6dBi are used, the power shall be reduced by the amount in dB that the directional gain of the antenna exceeds 6dBi.

3.2 Antenna Construction and Directional Gain

Antenna Type: Dipole antenna

Antenna Gain: 2 dBi

Connector: I-PEX (Reverse Polarity meets FCC part 15. 203 Requirement)



4. Test of Conducted Emission

4.1 Test Limit

Conducted Emissions were measured from 150 kHz to 30 MHz with a bandwidth of 9 KHz on the 120 VAC power and return leads of the EUT according to the methods defined in ANSI C63.4-2009 Section 3.1. The EUT was placed on a nonmetallic stand in a shielded room 0.8 meters above the ground plane as shown in section 2.2. The interface cables and equipment positioning were varied within limits of reasonable applications to determine the position produced maximum conducted emissions.

| Frequency (MHz) | Quasi Peak (dB μ V) | Average (dB μ V) |
|-----------------|-------------------------|----------------------|
| 0.15 – 0.5 | 66-56* | 56-46* |
| 0.5 – 5.0 | 56 | 46 |
| 5.0 – 30.0 | 60 | 50 |

*Decreases with the logarithm of the frequency.

4.2 Test Procedures

- a. The EUT was placed 0.4 meter from the conducting wall of the shielding room was kept at least 80 centimeters from any other grounded conducting surface.
- b. Connect EUT to the power mains through a line impedance stabilization network (LISN).
- c. All the support units are connecting to the other LISN.
- d. The LISN provides 50 ohm coupling impedance for the measuring instrument.
- e. The FCC states that a 50 ohm, 50 micro-Henry LISN should be used.
- f. Both sides of AC line were checked for maximum conducted interference.
- g. The frequency range from 150 kHz to 30 MHz was searched.
- h. Set the test-receiver system to Peak Detect Function and Specified Bandwidth with Maximum Hold Mode.



4.3 Typical Test Setup

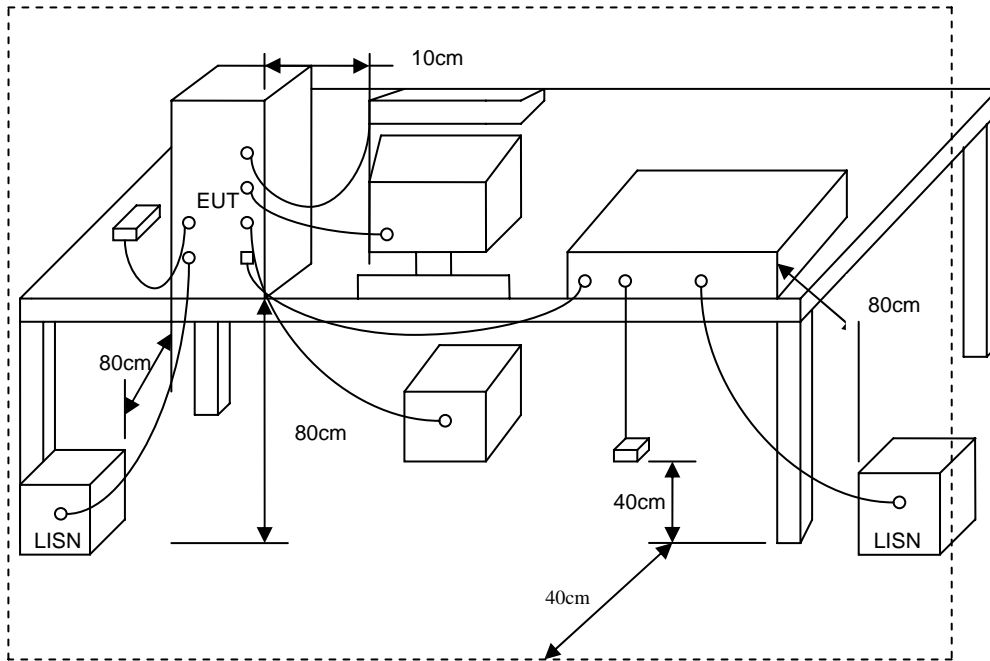

4.4 Measurement Equipment

| Instrument/Ancillary | Model No. | Manufacturer | Serial No. | Calibration Date | Valid Date |
|----------------------|-------------|--------------|------------|------------------|------------|
| EMI Receiver | R&S | ESCI | 100443 | 2011/02/08 | 2012/02/07 |
| LISN | Schwarzbeck | NSLK 8127 | 8127-516 | 2011/05/05 | 2012/05/04 |
| LISN | Schwarzbeck | NSLK 8127 | 8127-568 | 2011/08/24 | 2012/08/23 |



4.5 Test Result and Data

| | | | |
|-------------|-----------------|-------------|---------|
| Power | : AC 120V | Pol/Phase | : LINE |
| Test Mode 1 | : 802.11g, CH1 | Temperature | : 24 °C |
| Test Date | : Sep. 21, 2011 | Humidity | : 58 % |

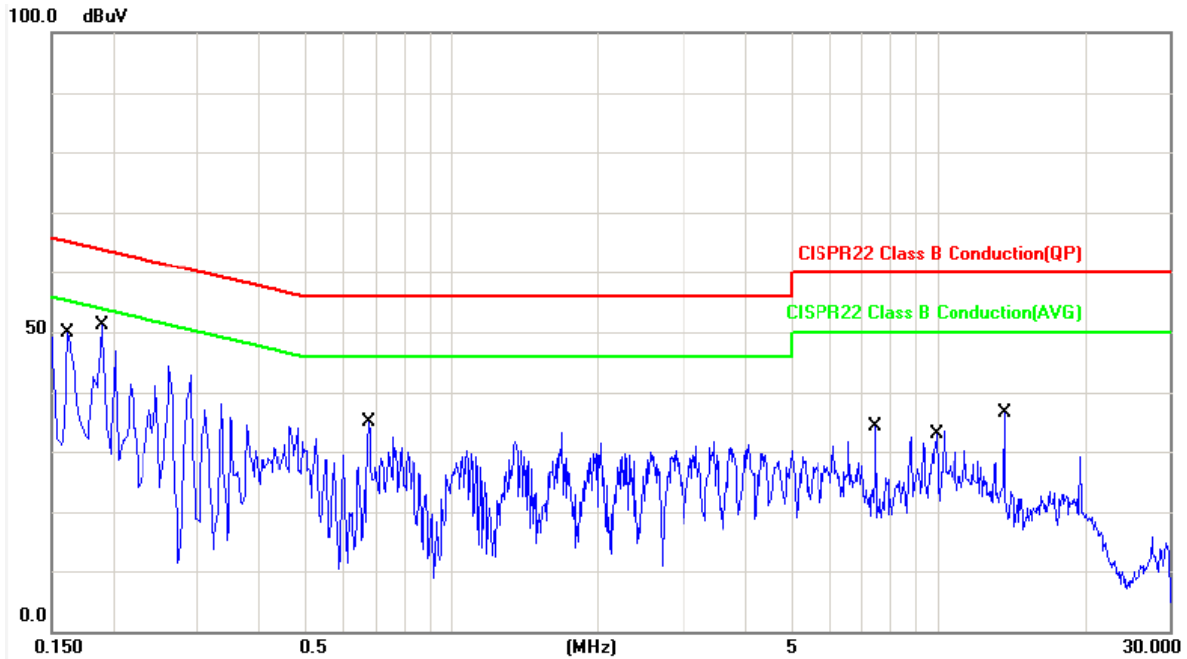

| No. | Frequency (MHz) | Factor (dBuV) | Reading (dBuV) | Level (dBuV) | Limit (dBuV) | Margin (dB) | Detector | P/F |
|-----|-----------------|---------------|----------------|--------------|--------------|-------------|----------|-----|
| 1 | 0.1620 | 0.12 | 46.72 | 46.84 | 65.36 | -18.52 | QP | P |
| 2 | 0.1620 | 0.12 | 36.49 | 36.61 | 55.36 | -18.75 | AVG | P |
| 3 | 0.1900 | 0.12 | 46.29 | 46.41 | 64.03 | -17.62 | QP | P |
| 4 | 0.1900 | 0.12 | 36.86 | 36.98 | 54.03 | -17.05 | AVG | P |
| 5 | 0.6740 | 0.15 | 35.66 | 35.81 | 56.00 | -20.19 | QP | P |
| 6 | 0.6740 | 0.15 | 33.11 | 33.26 | 46.00 | -12.74 | AVG | P |
| 7 | 7.4820 | 0.48 | 30.10 | 30.58 | 60.00 | -29.42 | QP | P |
| 8 | 7.4820 | 0.48 | 16.39 | 16.87 | 50.00 | -33.13 | AVG | P |
| 9 | 9.9140 | 0.58 | 17.86 | 18.44 | 60.00 | -41.56 | QP | P |
| 10 | 9.9140 | 0.58 | 9.71 | 10.29 | 50.00 | -39.71 | AVG | P |
| 11 | 13.7140 | 0.74 | 29.10 | 29.84 | 60.00 | -30.16 | QP | P |
| 12 | 13.7140 | 0.74 | 14.72 | 15.46 | 50.00 | -34.54 | AVG | P |



| | | | |
|-------------|-----------------|-------------|-----------|
| Power | : AC 120V | Pol/Phase | : NEUTRAL |
| Test Mode 1 | : 802.11g, CH1 | Temperature | : 24 °C |
| Test Date | : Sep. 21, 2011 | Humidity | : 58 % |

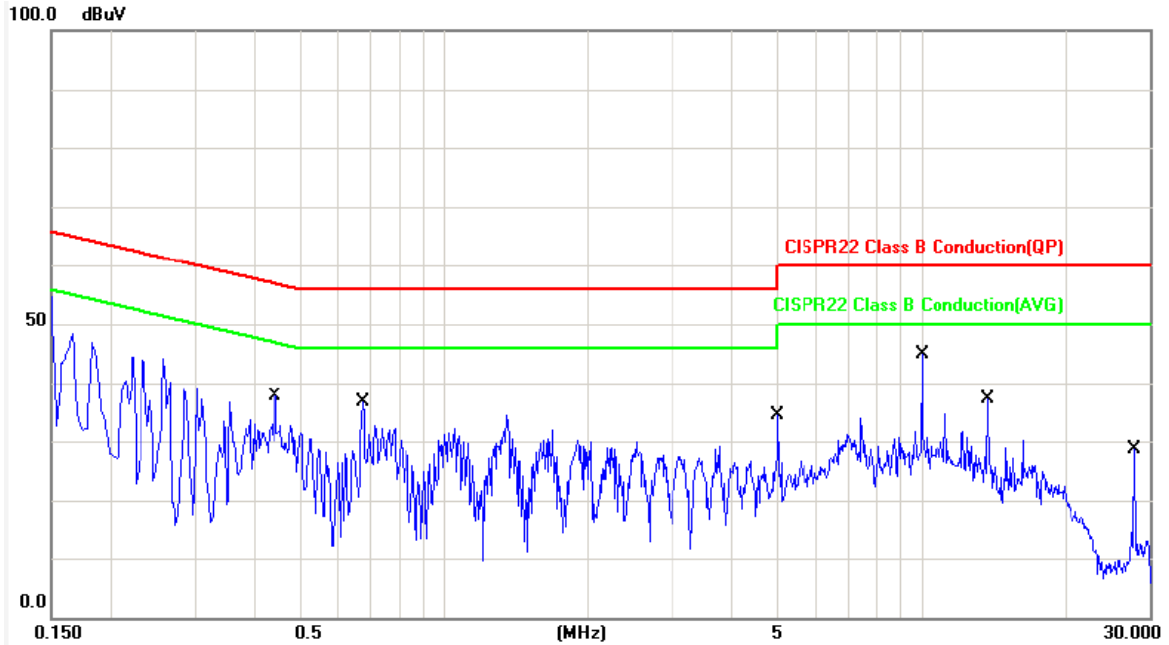

| No. | Frequency (MHz) | Factor (dBuV) | Reading (dBuV) | Level (dBuV) | Limit (dBuV) | Margin (dB) | Detector | P/F |
|-----|-----------------|---------------|----------------|--------------|--------------|-------------|----------|-----|
| 1 | 0.4420 | 0.12 | 32.53 | 32.65 | 57.02 | -24.37 | QP | P |
| 2 | 0.4420 | 0.12 | 22.03 | 22.15 | 47.02 | -24.87 | AVG | P |
| 3 | 0.6740 | 0.13 | 36.71 | 36.84 | 56.00 | -19.16 | QP | P |
| 4 | 0.6740 | 0.13 | 33.01 | 33.14 | 46.00 | -12.86 | AVG | P |
| 5 | 5.0020 | 0.36 | 28.18 | 28.54 | 60.00 | -31.46 | QP | P |
| 6 | 5.0020 | 0.36 | 23.15 | 23.51 | 50.00 | -26.49 | AVG | P |
| 7 | 10.0020 | 0.51 | 39.67 | 40.18 | 60.00 | -19.82 | QP | P |
| 8 | 10.0020 | 0.51 | 27.43 | 27.94 | 50.00 | -22.06 | AVG | P |
| 9 | 13.7540 | 0.60 | 23.04 | 23.64 | 60.00 | -36.36 | QP | P |
| 10 | 13.7540 | 0.60 | 19.54 | 20.14 | 50.00 | -29.86 | AVG | P |
| 11 | 27.9580 | 0.91 | 9.28 | 10.19 | 60.00 | -49.81 | QP | P |
| 12 | 27.9580 | 0.91 | 4.35 | 5.26 | 50.00 | -44.74 | AVG | P |



| | | | |
|-------------|---------------------|-------------|---------|
| Power | : AC 120V | Pol/Phase | : LINE |
| Test Mode 2 | : 802.11n HT20, CH1 | Temperature | : 24 °C |
| Test Date | : Sep. 21, 2011 | Humidity | : 58 % |

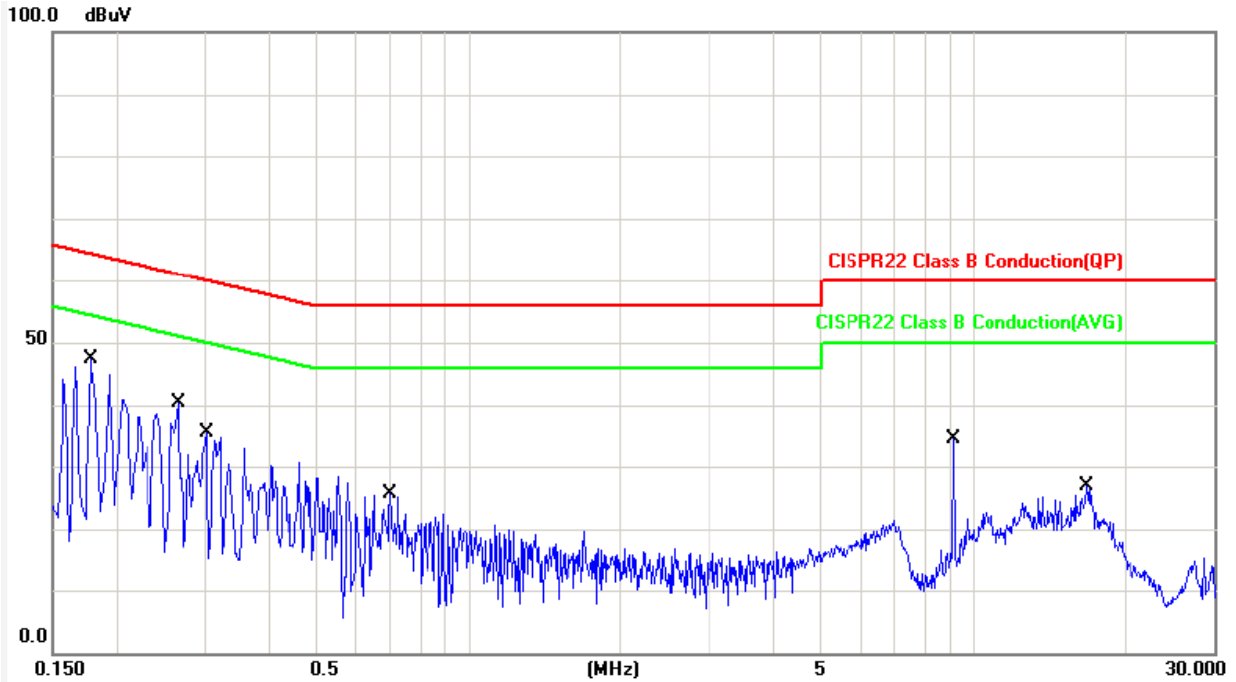

| No. | Frequency (MHz) | Factor (dBuV) | Reading (dBuV) | Level (dBuV) | Limit (dBuV) | Margin (dB) | Detector | P/F |
|-----|-----------------|---------------|----------------|--------------|--------------|-------------|----------|-----|
| 1 | 0.1780 | 0.12 | 40.00 | 40.12 | 64.57 | -24.45 | QP | P |
| 2 | 0.1780 | 0.12 | 23.53 | 23.65 | 54.57 | -30.92 | AVG | P |
| 3 | 0.2660 | 0.12 | 42.57 | 42.69 | 61.24 | -18.55 | QP | P |
| 4 | 0.2660 | 0.12 | 36.72 | 36.84 | 51.24 | -14.40 | AVG | P |
| 5 | 0.3020 | 0.12 | 28.82 | 28.94 | 60.19 | -31.25 | QP | P |
| 6 | 0.3020 | 0.12 | 15.53 | 15.65 | 50.19 | -34.54 | AVG | P |
| 7 | 0.6980 | 0.16 | 26.20 | 26.36 | 56.00 | -29.64 | QP | P |
| 8 | 0.6980 | 0.16 | 21.25 | 21.41 | 46.00 | -24.59 | AVG | P |
| 9 | 9.1220 | 0.55 | 15.33 | 15.88 | 60.00 | -44.12 | QP | P |
| 10 | 9.1220 | 0.55 | 11.14 | 11.69 | 50.00 | -38.31 | AVG | P |
| 11 | 16.7860 | 0.86 | 21.61 | 22.47 | 60.00 | -37.53 | QP | P |
| 12 | 16.7860 | 0.86 | 15.98 | 16.84 | 50.00 | -33.16 | AVG | P |



| | | | |
|-------------|---------------------|-------------|-----------|
| Power | : AC 120V | Pol/Phase | : NEUTRAL |
| Test Mode 2 | : 802.11n HT20, CH1 | Temperature | : 24 °C |
| Test Date | : Sep. 21, 2011 | Humidity | : 58 % |

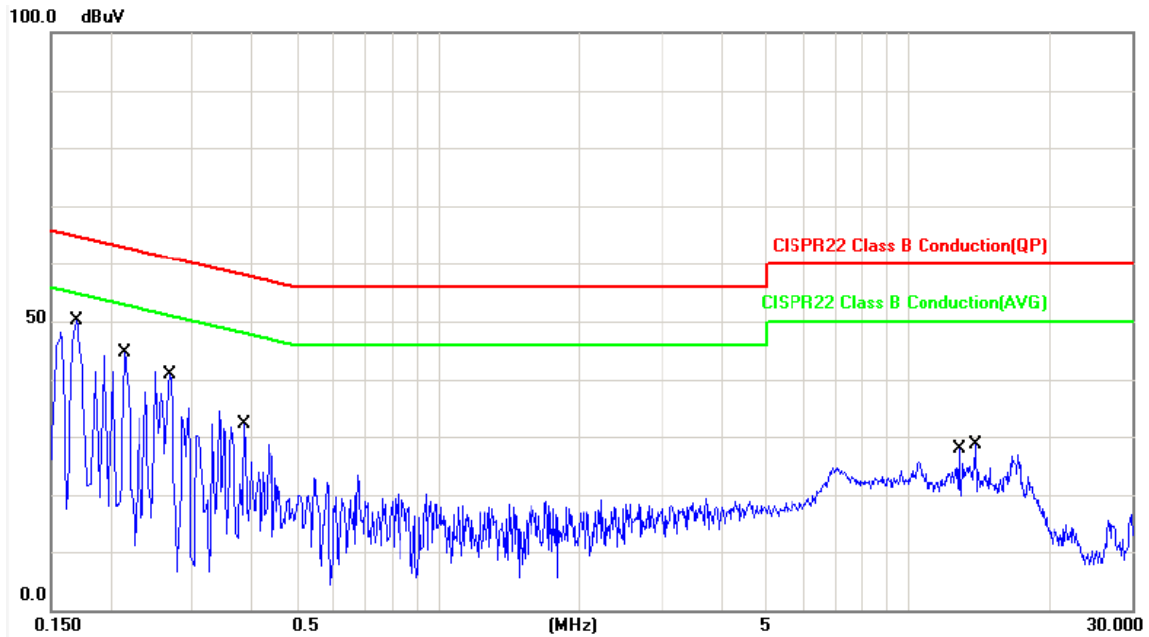

| No. | Frequency (MHz) | Factor (dBuV) | Reading (dBuV) | Level (dBuV) | Limit (dBuV) | Margin (dB) | Detector | P/F |
|-----|-----------------|---------------|----------------|--------------|--------------|-------------|----------|-----|
| 1 | 0.1700 | 0.10 | 48.52 | 48.62 | 64.96 | -16.34 | QP | P |
| 2 | 0.1700 | 0.10 | 32.05 | 32.15 | 54.96 | -22.81 | AVG | P |
| 3 | 0.2140 | 0.10 | 40.12 | 40.22 | 63.04 | -22.82 | QP | P |
| 4 | 0.2140 | 0.10 | 28.53 | 28.63 | 53.04 | -24.41 | AVG | P |
| 5 | 0.2700 | 0.10 | 35.52 | 35.62 | 61.12 | -25.50 | QP | P |
| 6 | 0.2700 | 0.10 | 23.11 | 23.21 | 51.12 | -27.91 | AVG | P |
| 7 | 0.3860 | 0.12 | 26.54 | 26.66 | 58.15 | -31.49 | QP | P |
| 8 | 0.3860 | 0.12 | 19.53 | 19.65 | 48.15 | -28.50 | AVG | P |
| 9 | 12.8940 | 0.58 | 19.78 | 20.36 | 60.00 | -39.64 | QP | P |
| 10 | 12.8940 | 0.58 | 14.96 | 15.54 | 50.00 | -34.46 | AVG | P |
| 11 | 13.9580 | 0.60 | 19.76 | 20.36 | 60.00 | -39.64 | QP | P |
| 12 | 13.9580 | 0.60 | 14.73 | 15.33 | 50.00 | -34.67 | AVG | P |



| | | | |
|-------------|---------------------|-------------|---------|
| Power | : AC 120V | Pol/Phase | : LINE |
| Test Mode 3 | : 802.11n HT40, CH3 | Temperature | : 24 °C |
| Test Date | : Sep. 21, 2011 | Humidity | : 58 % |

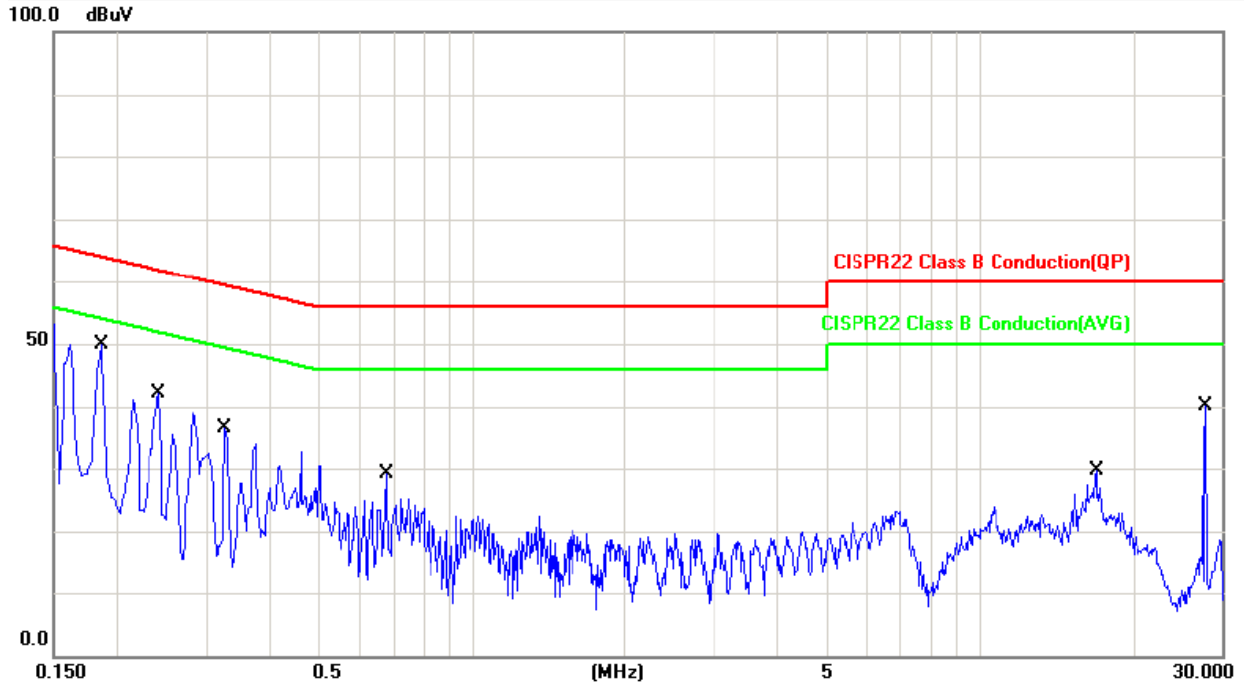

| No. | Frequency (MHz) | Factor (dBuV) | Reading (dBuV) | Level (dBuV) | Limit (dBuV) | Margin (dB) | Detector | P/F |
|-----|-----------------|---------------|----------------|--------------|--------------|-------------|----------|-----|
| 1 | 0.1860 | 0.12 | 45.57 | 45.69 | 64.21 | -18.52 | QP | P |
| 2 | 0.1860 | 0.12 | 33.53 | 33.65 | 54.21 | -20.56 | AVG | P |
| 3 | 0.2420 | 0.12 | 36.03 | 36.15 | 62.02 | -25.87 | QP | P |
| 4 | 0.2420 | 0.12 | 22.72 | 22.84 | 52.02 | -29.18 | AVG | P |
| 5 | 0.3260 | 0.12 | 32.24 | 32.36 | 59.55 | -27.19 | QP | P |
| 6 | 0.3260 | 0.12 | 19.44 | 19.56 | 49.55 | -29.99 | AVG | P |
| 7 | 0.6780 | 0.15 | 26.51 | 26.66 | 56.00 | -29.34 | QP | P |
| 8 | 0.6780 | 0.15 | 25.73 | 25.88 | 46.00 | -20.12 | AVG | P |
| 9 | 16.9740 | 0.87 | 22.32 | 23.19 | 60.00 | -36.81 | QP | P |
| 10 | 16.9740 | 0.87 | 17.78 | 18.65 | 50.00 | -31.35 | AVG | P |
| 11 | 27.9580 | 1.28 | 19.08 | 20.36 | 60.00 | -39.64 | QP | P |
| 12 | 27.9580 | 1.28 | 14.14 | 15.42 | 50.00 | -34.58 | AVG | P |



| | | | |
|-------------|---------------------|-------------|-----------|
| Power | : AC 120V | Pol/Phase | : NEUTRAL |
| Test Mode 3 | : 802.11n HT40, CH3 | Temperature | : 24 °C |
| Test Date | : Sep. 21, 2011 | Humidity | : 58 % |

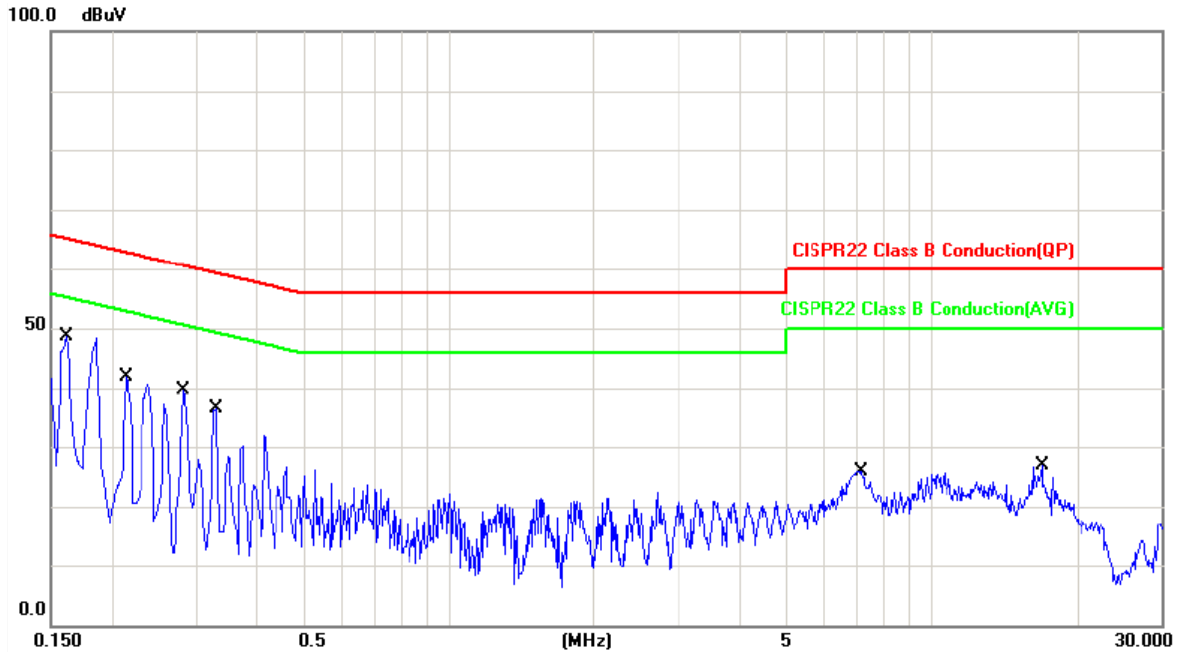

| No. | Frequency (MHz) | Factor (dBuV) | Reading (dBuV) | Level (dBuV) | Limit (dBuV) | Margin (dB) | Detector | P/F |
|-----|-----------------|---------------|----------------|--------------|--------------|-------------|----------|-----|
| 1 | 0.1620 | 0.10 | 48.42 | 48.52 | 65.36 | -16.84 | QP | P |
| 2 | 0.1620 | 0.10 | 35.08 | 35.18 | 55.36 | -20.18 | AVG | P |
| 3 | 0.2140 | 0.10 | 40.45 | 40.55 | 63.04 | -22.49 | QP | P |
| 4 | 0.2140 | 0.10 | 25.53 | 25.63 | 53.04 | -27.41 | AVG | P |
| 5 | 0.2819 | 0.10 | 36.13 | 36.23 | 60.76 | -24.53 | QP | P |
| 6 | 0.2819 | 0.10 | 28.44 | 28.54 | 50.76 | -22.22 | AVG | P |
| 7 | 0.3300 | 0.10 | 29.53 | 29.63 | 59.45 | -29.82 | QP | P |
| 8 | 0.3300 | 0.10 | 18.35 | 18.45 | 49.45 | -31.00 | AVG | P |
| 9 | 7.2100 | 0.42 | 24.10 | 24.52 | 60.00 | -35.48 | QP | P |
| 10 | 7.2100 | 0.42 | 22.21 | 22.63 | 50.00 | -27.37 | AVG | P |
| 11 | 16.9740 | 0.67 | 20.87 | 21.54 | 60.00 | -38.46 | QP | P |
| 12 | 16.9740 | 0.67 | 16.02 | 16.69 | 50.00 | -33.31 | AVG | P |

Test engineer: Ben



4.6 Test Photographs

Front View

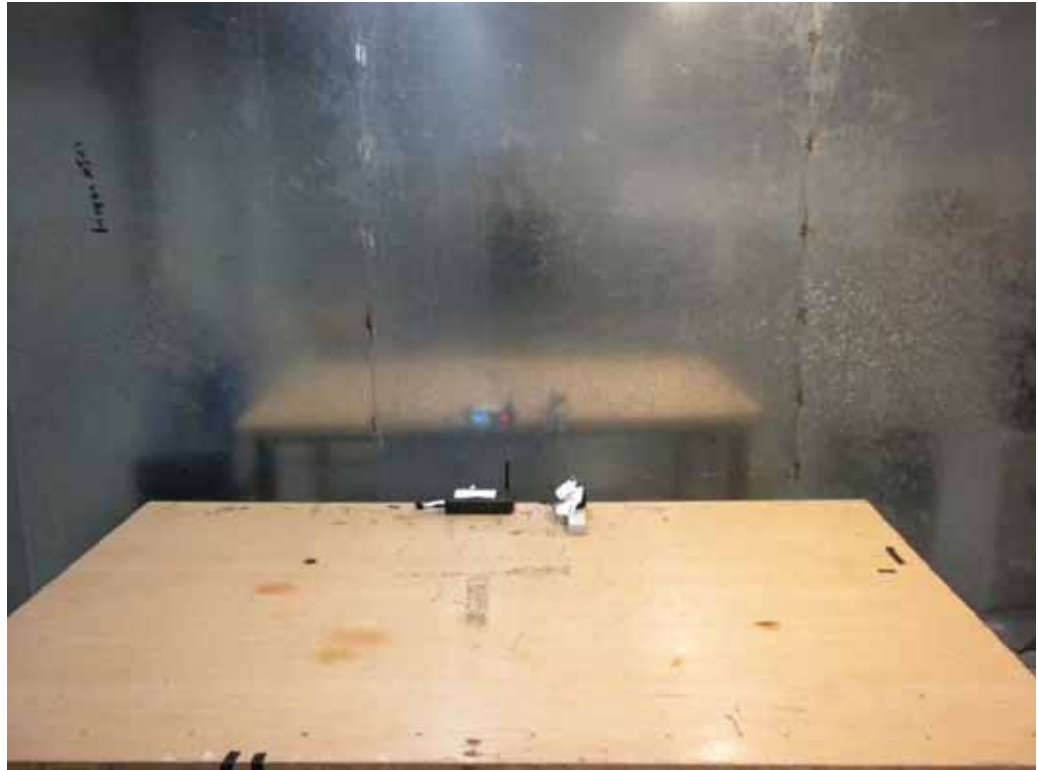

Rear View

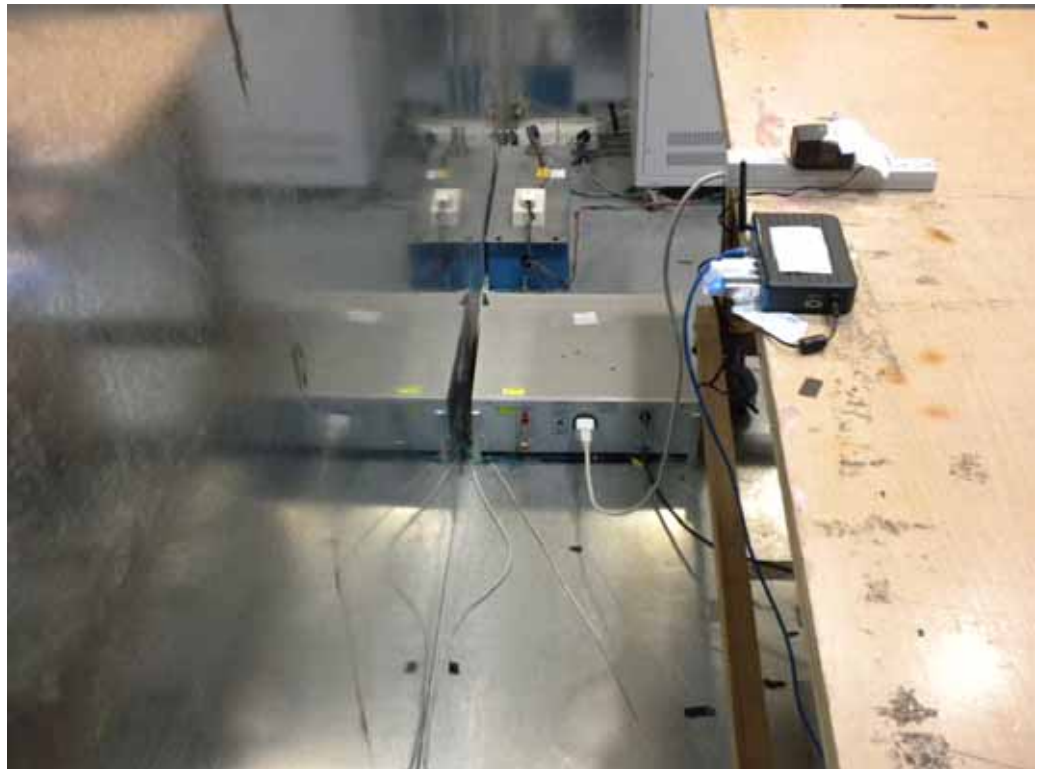



5. Test of Radiated Emission

5.1 Test Limit

Radiated emissions from 30 MHz to 25 GHz were measured according to the methods defines in ANSI C63.4-2009. The EUT was placed, 0.8 meter above the ground plane, as shown in section 5.6.3. The interface cables and equipment positions were varied within limits of reasonable applications to determine the positions producing maximum radiated emissions for unintentional device, according to § 15.109(a), except for Class A digital devices, the field strength of radiated emissions from unintentional radiators at a distance of 3 meters shall not exceed the following values:

| Frequency (MHz) | Distance Meters | Radiated (μ V / M) | Radiated (dB μ V / M) |
|-----------------|-----------------|-------------------------|---------------------------|
| 30-88 | 3 | 100 | 40.0 |
| 88-216 | 3 | 150 | 43.5 |
| 216-960 | 3 | 200 | 46.0 |
| Above 960 | 3 | 500 | 54.0 |

For unintentional device, according to CISPR PUB.22, for Class B digital devices, the general requirement of field strength of radiated emissions from intentional radiators at a distance of 10 meters shall not exceed the below table.

| Frequency (MHz) | Distance Meters | Radiated (dB μ V / M) |
|-----------------|-----------------|---------------------------|
| 30-230 | 10 | 30 |
| 230-1000 | 10 | 37 |

5.2 Test Procedures

- b. The EUT was placed on a rotatable table top 0.8 meter above ground.
- c. The EUT was set 3 meters from the interference receiving antenna which was mounted on the top of a variable height antenna tower.
- d. The table was rotated 360 degrees to determine the position of the highest radiation.
- e. The antenna is a broadband antenna and its height is varied between one meter and four meters above ground to find the maximum value of the field strength both horizontal polarization and vertical polarization of the antenna are set to make the measurement.
- f. For each suspected emission the EUT was arranged to its worst case and then tune the antenna tower (from 1 M to 4 M) and turn table (from 0 degree to 360 degrees) to find the maximum reading.
- g. Set the test-receiver system to Peak or CISPR quasi-peak Detect Function and specified bandwidth with Maximum Hold Mode.
- h. If the emission level of the EUT in peak mode was 3 dB lower than the limit specified, then testing will be stopped and peak values of EUT will be reported, otherwise, the emissions which do not have 3 dB margin will be repeated one by one using the quasi-peak method and reported.
- i. For testing above 1GHz, the emission level of the EUT in peak mode was 20dB lower than average limit (that means the emission level in peak mode also complies with the limit in average mode), then testing will be stopped and peak values of EUT will be reported, otherwise, the emissions will be measured in average mode again and reported.
- j. "Cone of radiation" has been considered to be 3dB bandwidth of the measurement antenna.



5.3 Typical Test Setup

Below 1GHz Test Setup

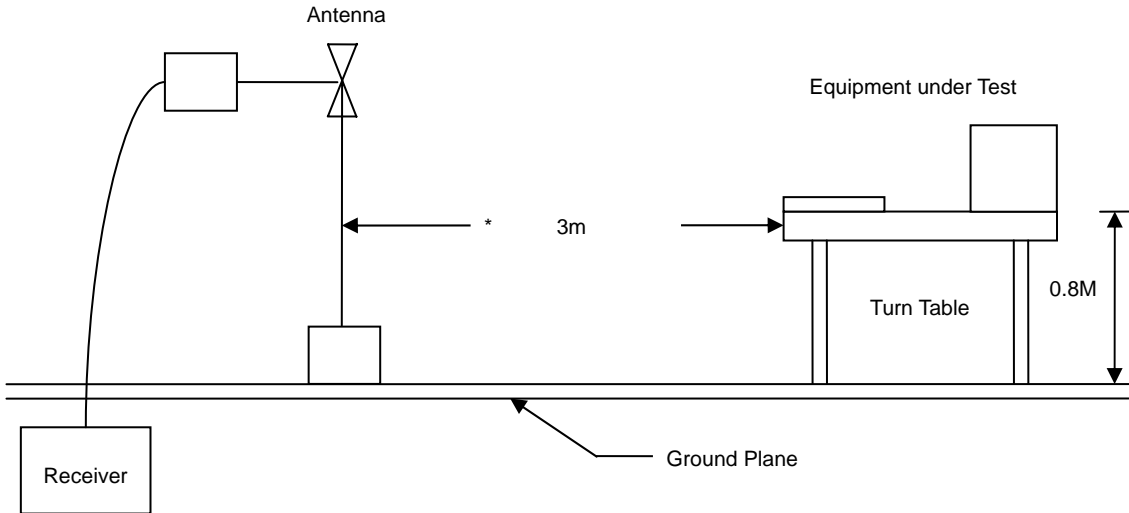

Above 1GHz Test Setup

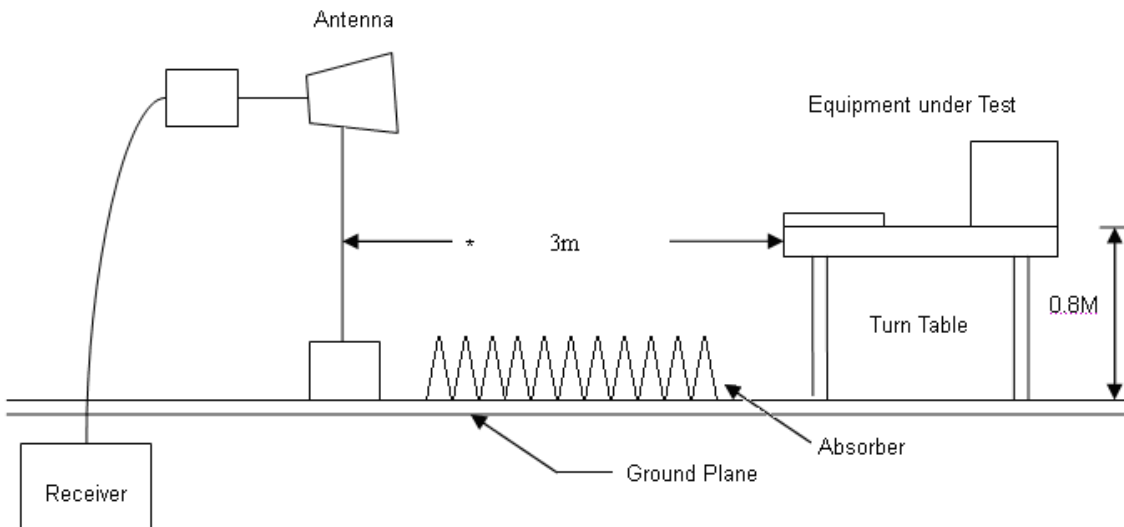

5.4 Measurement Equipment

| Instrument/Ancillary | Manufacturer | Model No. | Serial No. | Calibration Date | Valid Date |
|----------------------|--------------|-----------|------------|------------------|------------|
| Amplifier | Agilent | 8447D | 2944A10531 | 2011/01/21 | 2012/01/20 |
| Bilog Antenna | Schaffner | CBL6112D | 22242 | 2011/02/09 | 2012/02/08 |
| EMI Receiver | HP | 8546A | 3807A00454 | 2010/09/27 | 2011/09/26 |
| RF Filter Section | HP | 85460A | 3704A00386 | 2010/09/27 | 2011/09/26 |
| Spectrum Analyzer | R&S | FSP40 | 100219 | 2010/11/05 | 2011/11/04 |
| Horn Antenna | EMCO | 3115 | 31589 | 2011/05/02 | 2012/05/01 |
| Preamplifier | Agilent | 8449B | 3008A01954 | 2011/03/02 | 2012/03/01 |



5.5 Test Result and Data

| | | | |
|-------------|----------------|-------------|------------|
| Power | : AC 120V | Pol/Phase | : VERTICAL |
| Test Mode 1 | : 802.11g, CH1 | Temperature | : 23 °C |
| Memo | : | Humidity | : 65 % |

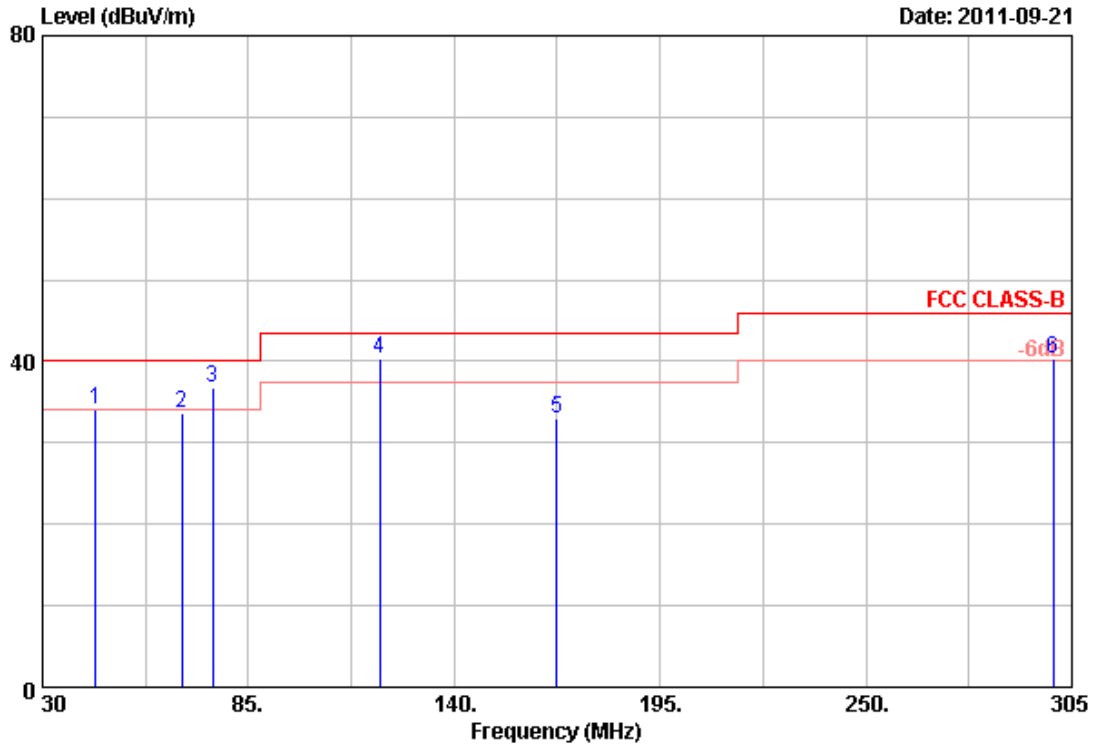

| Item | Freq MHz | Read Value dBUV | Factor dB/m | Result dBUV/m | Limit dBUV/m | Margin dB | Remark | Ant Pos cm | Tab Pos Deg |
|------|-------------|-----------------------|----------------|------------------|-----------------|--------------|--------|------------------|-------------------|
| 1 | 44.30 | 31.04 | 3.12 | 34.16 | 40.00 | -5.84 | QP | 100 | 360 |
| 2 | 67.13 | 41.90 | -8.16 | 33.74 | 40.00 | -6.26 | Peak | 100 | 360 |
| 3 | 75.38 | 42.70 | -6.00 | 36.70 | 40.00 | -3.30 | QP | 100 | 360 |
| 4 | 120.20 | 32.56 | 7.80 | 40.36 | 43.50 | -3.14 | QP | 100 | 360 |
| 5 | 167.50 | 34.14 | -1.24 | 32.90 | 43.50 | -10.60 | Peak | 100 | 360 |
| 6 | 300.05 | 44.44 | -4.15 | 40.29 | 46.00 | -5.71 | QP | 100 | 360 |

Notes:

1. Result = Read Value + Factor
2. Factor = Antenna Factor + Cable Loss - Amplifier
3. The resolution bandwidth of test receiver/spectrum analyzer is 120KHz and video bandwidth is 300kHz for Peak detection and Quasi-peak detection at frequency below 1GHz.
4. All emission below 1GHz at 802.11g/n mode are all the same,so the 802.11g/n mode chosen as representative in final test.
5. According to technical experiences,all spurious emission of 802.11g/n mode at channel 1,6,11 or 3,6,9(for HT40) are almost the same below 1GHz,so that the channel 1 or 3(for HT40)was chosen as representative in final test.
6. The data is worse case.



| | | | |
|-------------|----------------|-------------|------------|
| Power | : AC 120V | Pol/Phase | : VERTICAL |
| Test Mode 1 | : 802.11g, CH1 | Temperature | : 23 °C |
| Memo | : | Humidity | : 65 % |

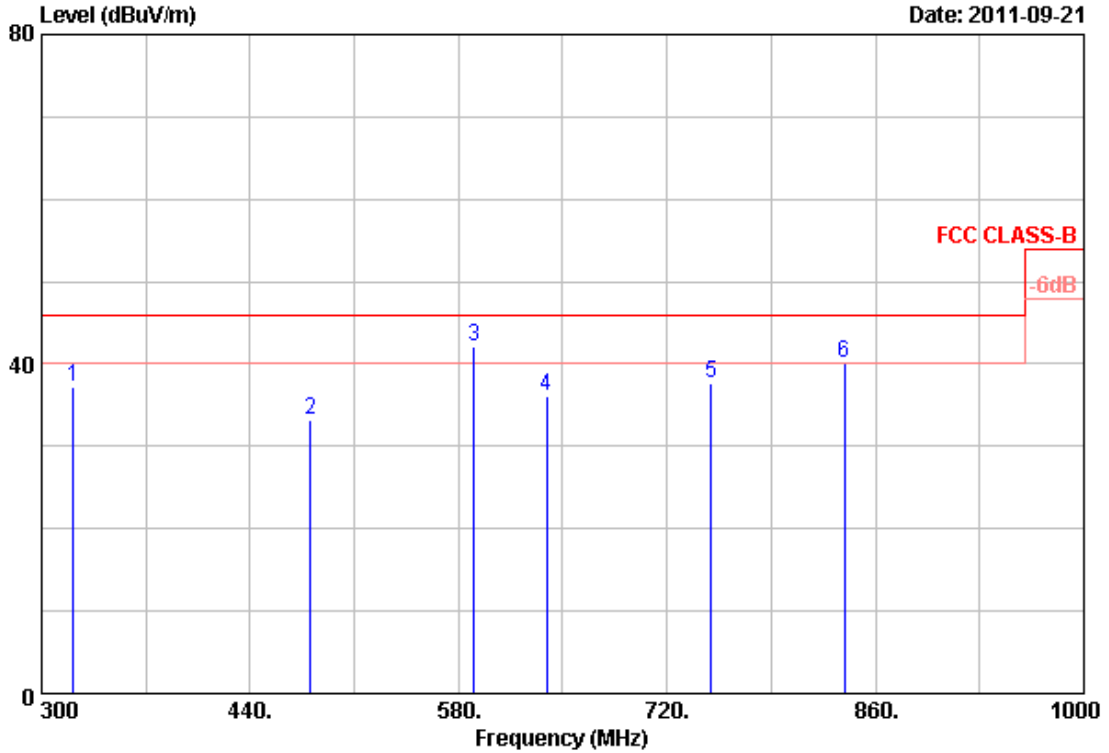

| Item | Freq | Read Value | Factor | Result | Limit | Margin | Remark | Ant Pos | Tab Pos |
|------|--------|------------|--------|--------|--------|--------|--------|---------|---------|
| | MHz | dBuV | dB/m | dBuV/m | dBuV/m | dB | | cm | Deg |
| 1 | 321.00 | 41.39 | -4.14 | 37.25 | 46.00 | -8.75 | Peak | 100 | 0 |
| 2 | 480.60 | 33.81 | -0.65 | 33.16 | 46.00 | -12.84 | Peak | 100 | 0 |
| 3 | 590.50 | 35.88 | 6.33 | 42.21 | 46.00 | -3.79 | QP | 100 | 0 |
| 4 | 639.50 | 32.58 | 3.46 | 36.04 | 46.00 | -9.96 | Peak | 100 | 0 |
| 5 | 749.40 | 29.38 | 8.23 | 37.61 | 46.00 | -8.39 | Peak | 100 | 0 |
| 6 | 839.00 | 24.97 | 15.21 | 40.18 | 46.00 | -5.82 | QP | 100 | 0 |

Notes:

1. Result = Read Value + Factor
2. Factor = Antenna Factor + Cable Loss - Amplifier
3. The resolution bandwidth of test receiver/spectrum analyzer is 120KHz and video bandwidth is 300kHz for Peak detection and Quasi-peak detection at frequency below 1GHz.
4. All emission below 1GHz at 802.11b/g/n mode are all the same,so the 802.11g/n mode chosen as representative in final test.
5. According to technical experiences,all spurious emission of 802.11g/n mode at channel 1,6,11 or 3,6,9(for HT40) are almost the same below 1GHz,so that the channel 1 or 3(for HT40)was chosen as representative in final test.
6. The data is worse case.



| | | | |
|-------------|----------------|-------------|--------------|
| Power | : AC 120V | Pol/Phase | : HORIZONTAL |
| Test Mode 1 | : 802.11g, CH1 | Temperature | : 23 °C |
| Memo | : | Humidity | : 65 % |

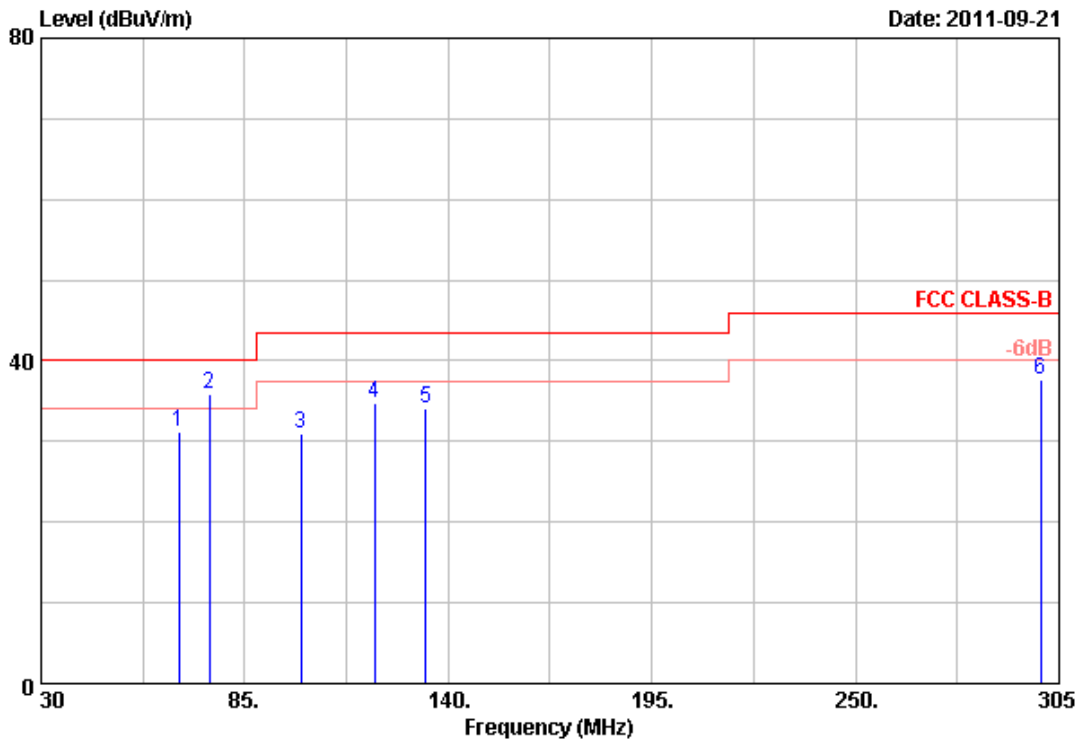

| Item | Freq | Read Value | Factor | Result | Limit | Margin | Remark | Ant Pos | Tab Pos |
|------|--------|------------|--------|--------|--------|--------|--------|---------|---------|
| | MHz | dBuV | dB/m | dBuV/m | dBuV/m | dB | | cm | Deg |
| 1 | 67.13 | 46.79 | -15.64 | 31.15 | 40.00 | -8.85 | Peak | 100 | 360 |
| 2 | 75.38 | 50.50 | -14.67 | 35.83 | 40.00 | -4.17 | QP | 100 | 360 |
| 3 | 100.13 | 38.98 | -8.02 | 30.96 | 43.50 | -12.54 | Peak | 100 | 360 |
| 4 | 120.20 | 44.94 | -10.27 | 34.67 | 43.50 | -8.83 | Peak | 100 | 360 |
| 5 | 133.95 | 43.72 | -9.64 | 34.08 | 43.50 | -9.42 | Peak | 100 | 360 |
| 6 | 300.05 | 43.84 | -6.07 | 37.77 | 46.00 | -8.23 | Peak | 100 | 360 |

Notes:

1. Result = Read Value + Factor
2. Factor = Antenna Factor + Cable Loss - Amplifier
3. The resolution bandwidth of test receiver/spectrum analyzer is 120KHz and video bandwidth is 300kHz for Peak detection and Quasi-peak detection at frequency below 1GHz.
4. All emission below 1GHz at 802.11g/n mode are all the same,so the 802.11g/n mode chosen as representative in final test.
5. According to technical experiences,all spurious emission of 802.11g/n mode at channel 1,6,11 or 3,6,9(for HT40) are almost the same below 1GHz,so that the channel 1 or 3(for HT40)was chosen as representative in final test.
6. The data is worse case.



| | | | |
|-------------|----------------|-------------|--------------|
| Power | : AC 120V | Pol/Phase | : HORIZONTAL |
| Test Mode 1 | : 802.11g, CH1 | Temperature | : 23 °C |
| Memo | : | Humidity | : 65 % |

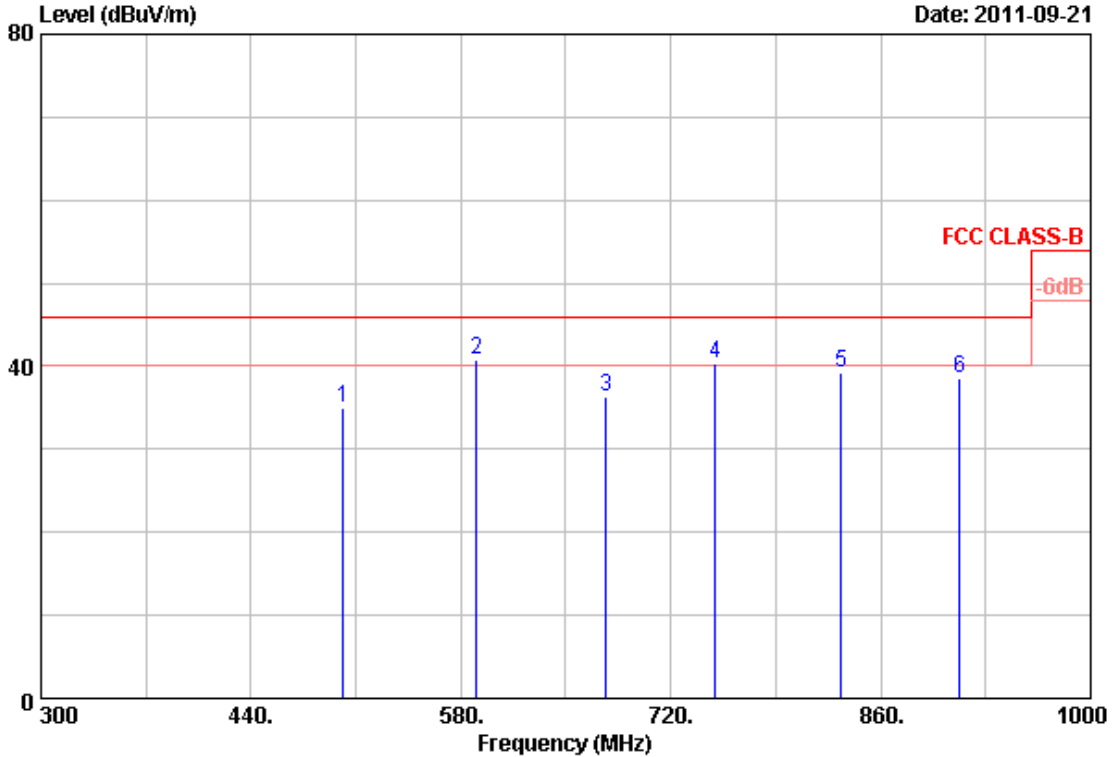

| Item | Freq | Read Value | Factor | Result | Limit | Margin | Remark | Ant Pos | Tab Pos |
|------|--------|------------|--------|--------|--------|--------|--------|---------|---------|
| | MHz | dBuV | dB/m | dBuV/m | dBuV/m | dB | | cm | Deg |
| 1 | 501.60 | 32.46 | 2.59 | 35.05 | 46.00 | -10.95 | Peak | 100 | 0 |
| 2 | 590.50 | 32.54 | 8.31 | 40.85 | 46.00 | -5.15 | QP | 100 | 0 |
| 3 | 676.60 | 29.77 | 6.47 | 36.24 | 46.00 | -9.76 | Peak | 100 | 0 |
| 4 | 749.40 | 32.50 | 7.75 | 40.25 | 46.00 | -5.75 | Peak | 100 | 0 |
| 5 | 833.40 | 25.48 | 13.72 | 39.20 | 46.00 | -6.80 | Peak | 100 | 0 |
| 6 | 912.50 | 27.28 | 11.28 | 38.56 | 46.00 | -7.44 | Peak | 100 | 0 |

Notes:

1. Result = Read Value + Factor
2. Factor = Antenna Factor + Cable Loss - Amplifier
3. The resolution bandwidth of test receiver/spectrum analyzer is 120KHz and video bandwidth is 300kHz for Peak detection and Quasi-peak detection at frequency below 1GHz.
4. All emission below 1GHz at 802.11g/n mode are all the same,so the 802.11g/n mode chosen as representative in final test.
5. According to technical experiences,all spurious emission of 802.11g/n mode at channel 1,6,11 or 3,6,9(for HT40) are almost the same below 1GHz,so that the channel 1 or 3(for HT40)was chosen as representative in final test.
6. The data is worse case.



| | | | |
|-------------|----------------|-------------|------------|
| Power | : AC 120V | Pol/Phase | : VERTICAL |
| Test Mode 1 | : 802.11b, CH1 | Temperature | : 23 °C |
| Memo | : | Humidity | : 65 % |

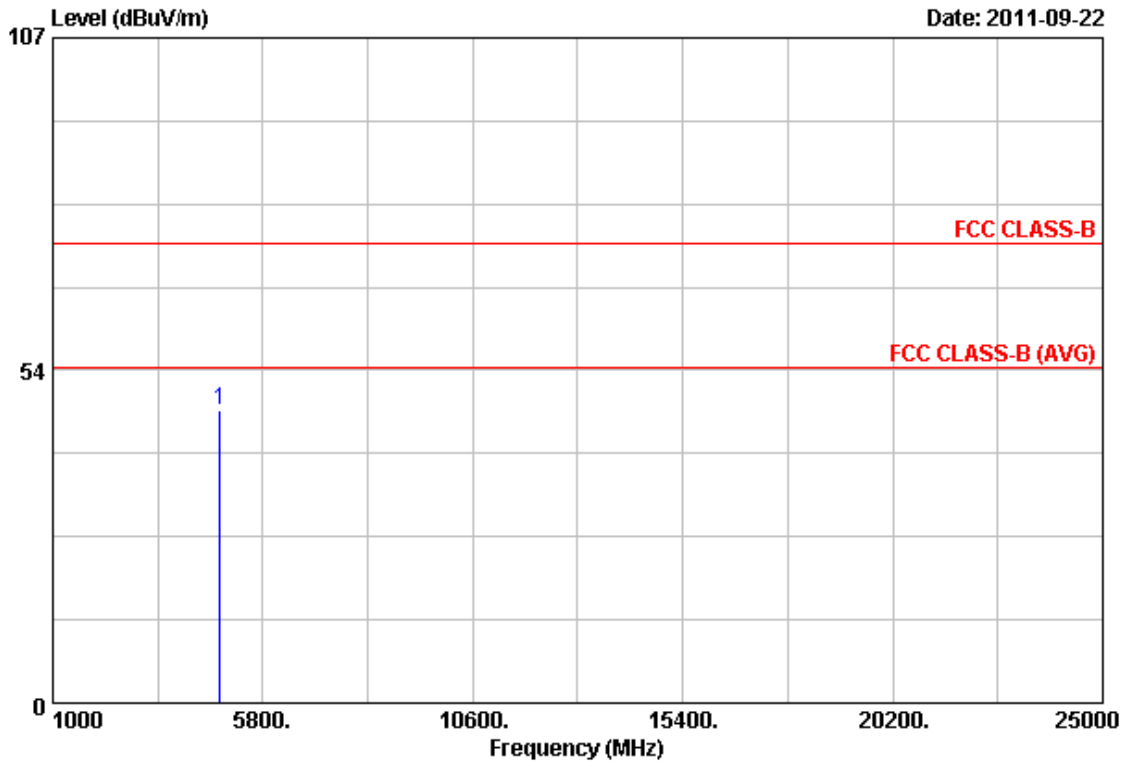

| Item | Freq | Read Value | Factor | Result | Limit | Margin | Remark | Ant Pos | Tab Pos |
|------|---------|------------|--------|--------|--------|--------|--------|---------|---------|
| | MHz | dBuV | dB/m | dBuV/m | dBuV/m | dB | | cm | Deg |
| 1 | 4824.00 | 41.78 | 5.37 | 47.15 | 74.00 | -26.85 | Peak | 100 | 224 |

Notes:

1. Result = Read Value + Factor
2. Factor = Antenna Factor + Cable Loss - Amplifier
3. The resolution bandwidth of test receiver/spectrum analyzer is 120KHz and video bandwidth is 300kHz for Peak detection and Quasi-peak detection at frequency below 1GHz.
4. The resolution bandwidth of test receiver/spectrum analyzer is 1MHz and video bandwidth is 3MHz for Peak detection at frequency above 1GHz.
5. The resolution bandwidth of test receiver/spectrum analyzer is 1MHz and video bandwidth is 10Hz for Average detection at frequency above 1GHz.
6. The other emissions is too low to be measured.
7. The data is worse case.



| | | | |
|-------------|----------------|-------------|--------------|
| Power | : AC 120V | Pol/Phase | : HORIZONTAL |
| Test Mode 1 | : 802.11b, CH1 | Temperature | : 23 °C |
| Memo | : | Humidity | : 65 % |

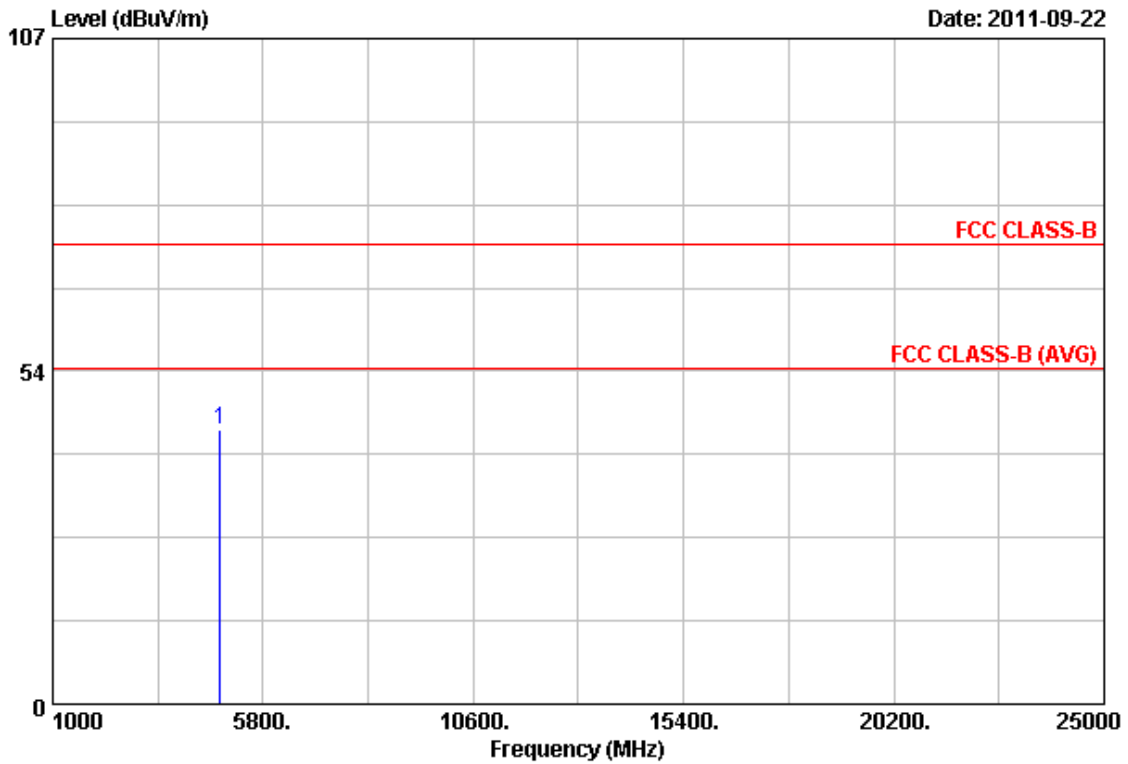

| Item | Freq | Read Value | Factor | Result | Limit | Margin | Remark | Ant Pos | Tab Pos |
|------|---------|------------|--------|--------|--------|--------|--------|---------|---------|
| | MHz | dBuV | dB/m | dBuV/m | dBuV/m | dB | | cm | Deg |
| 1 | 4824.00 | 40.44 | 3.71 | 44.15 | 74.00 | -29.85 | Peak | 100 | 121 |

Notes:

1. Result = Read Value + Factor
2. Factor = Antenna Factor + Cable Loss - Amplifier
3. The resolution bandwidth of test receiver/spectrum analyzer is 120KHz and video bandwidth is 300kHz for Peak detection and Quasi-peak detection at frequency below 1GHz.
4. The resolution bandwidth of test receiver/spectrum analyzer is 1MHz and video bandwidth is 3MHz for Peak detection at frequency above 1GHz.
5. The resolution bandwidth of test receiver/spectrum analyzer is 1MHz and video bandwidth is 10Hz for Average detection at frequency above 1GHz.
6. The other emissions is too low to be measured.
7. The data is worse case.



| | | | |
|-------------|----------------|-------------|------------|
| Power | : AC 120V | Pol/Phase | : VERTICAL |
| Test Mode 1 | : 802.11b, CH6 | Temperature | : 23 °C |
| Memo | : | Humidity | : 65 % |

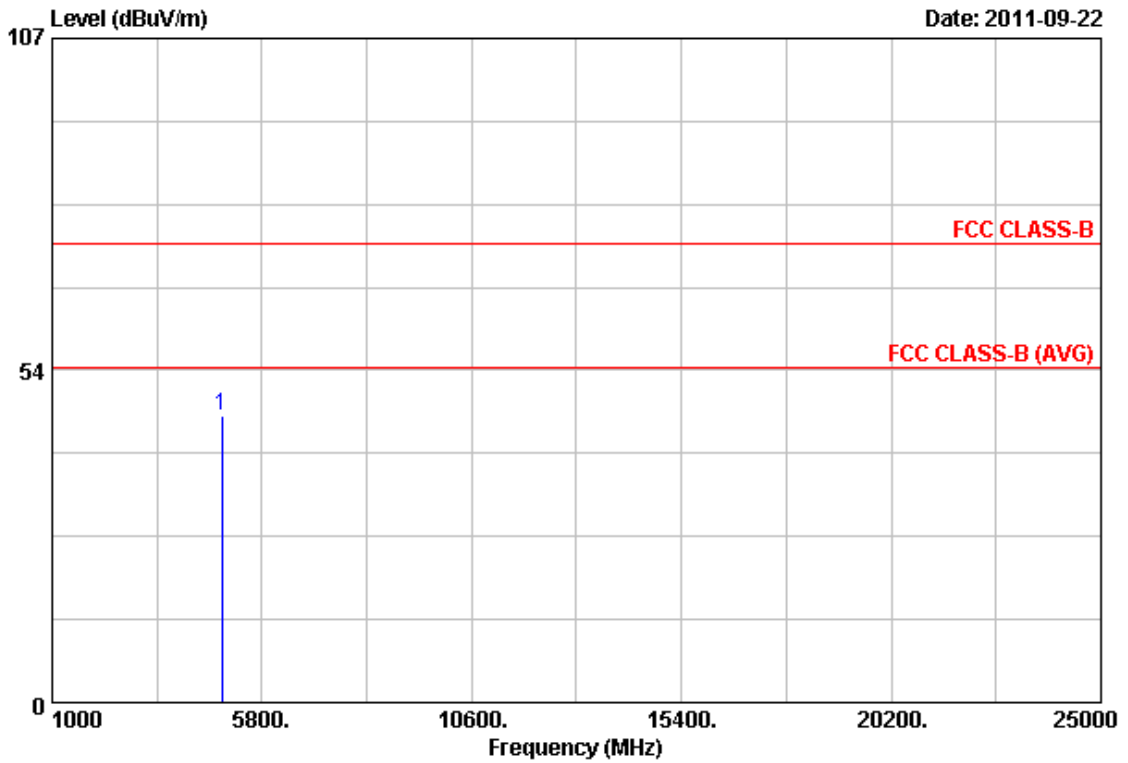

| Item | Freq | Read Value | Factor | Result | Limit | Margin | Remark | Ant Pos | Tab Pos |
|------|---------|------------|--------|--------|--------|--------|--------|---------|---------|
| | MHz | dBuV | dB/m | dBuV/m | dBuV/m | dB | | cm | Deg |
| 1 | 4874.00 | 39.92 | 6.36 | 46.28 | 74.00 | -27.72 | Peak | 100 | 222 |

Notes:

1. Result = Read Value + Factor
2. Factor = Antenna Factor + Cable Loss - Amplifier
3. The resolution bandwidth of test receiver/spectrum analyzer is 120KHz and video bandwidth is 300kHz for Peak detection and Quasi-peak detection at frequency below 1GHz.
4. The resolution bandwidth of test receiver/spectrum analyzer is 1MHz and video bandwidth is 3MHz for Peak detection at frequency above 1GHz.
5. The resolution bandwidth of test receiver/spectrum analyzer is 1MHz and video bandwidth is 10Hz for Average detection at frequency above 1GHz.
6. The other emissions is too low to be measured.
7. The data is worse case.



| | | | |
|-------------|----------------|-------------|--------------|
| Power | : AC 120V | Pol/Phase | : HORIZONTAL |
| Test Mode 1 | : 802.11b, CH6 | Temperature | : 23 °C |
| Memo | : | Humidity | : 65 % |

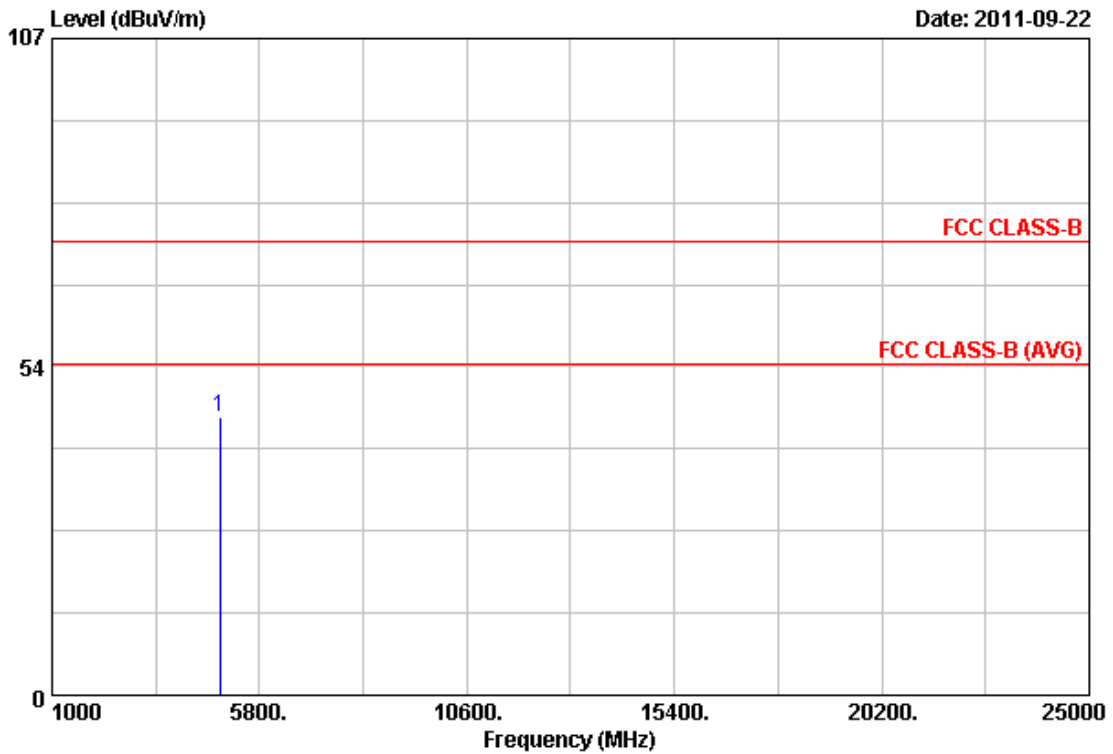

| Item | Freq | Read Value | Factor | Result | Limit | Margin | Remark | Ant Pos | Tab Pos |
|------|---------|------------|--------|--------|--------|--------|--------|---------|---------|
| | MHz | dBuV | dB/m | dBuV/m | dBuV/m | dB | | cm | Deg |
| 1 | 4874.00 | 40.85 | 4.50 | 45.35 | 74.00 | -28.65 | Peak | 100 | 120 |

Notes:

1. Result = Read Value + Factor
2. Factor = Antenna Factor + Cable Loss - Amplifier
3. The resolution bandwidth of test receiver/spectrum analyzer is 120KHz and video bandwidth is 300kHz for Peak detection and Quasi-peak detection at frequency below 1GHz.
4. The resolution bandwidth of test receiver/spectrum analyzer is 1MHz and video bandwidth is 3MHz for Peak detection at frequency above 1GHz.
5. The resolution bandwidth of test receiver/spectrum analyzer is 1MHz and video bandwidth is 10Hz for Average detection at frequency above 1GHz.
6. The other emissions is too low to be measured.
7. The data is worse case.



| | | | |
|-------------|-----------------|-------------|------------|
| Power | : AC 120V | Pol/Phase | : VERTICAL |
| Test Mode 1 | : 802.11b, CH11 | Temperature | : 23 °C |
| Memo | : | Humidity | : 65 % |

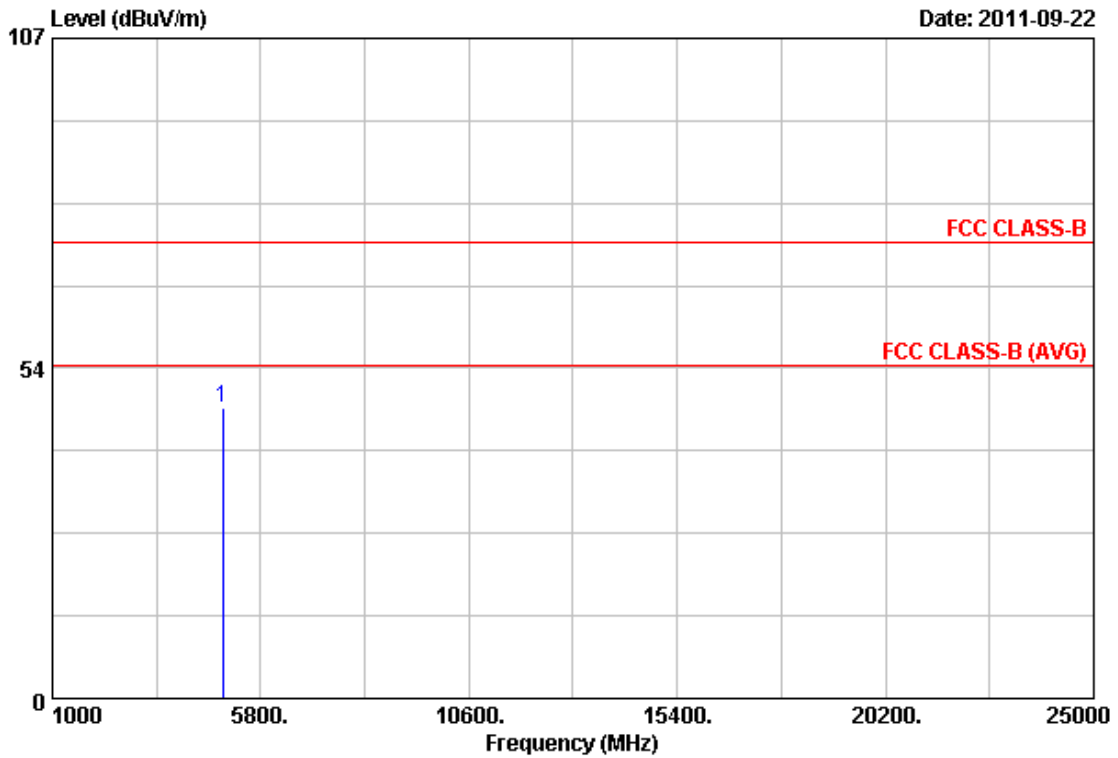

| Item | Freq | Read Value | Factor | Result | Limit | Margin | Remark | Ant Pos | Tab Pos |
|------|---------|------------|--------|--------|--------|--------|--------|---------|---------|
| | MHz | dBuV | dB/m | dBuV/m | dBuV/m | dB | | cm | Deg |
| 1 | 4924.00 | 40.12 | 6.94 | 47.06 | 74.00 | -26.94 | Peak | 100 | 222 |

Notes:

1. Result = Read Value + Factor
2. Factor = Antenna Factor + Cable Loss - Amplifier
3. The resolution bandwidth of test receiver/spectrum analyzer is 120KHz and video bandwidth is 300kHz for Peak detection and Quasi-peak detection at frequency below 1GHz.
4. The resolution bandwidth of test receiver/spectrum analyzer is 1MHz and video bandwidth is 3MHz for Peak detection at frequency above 1GHz.
5. The resolution bandwidth of test receiver/spectrum analyzer is 1MHz and video bandwidth is 10Hz for Average detection at frequency above 1GHz.
6. The other emissions is too low to be measured.
7. The data is worse case.



| | | | |
|-------------|-----------------|-------------|--------------|
| Power | : AC 120V | Pol/Phase | : HORIZONTAL |
| Test Mode 1 | : 802.11b, CH11 | Temperature | : 23 °C |
| Memo | : | Humidity | : 65 % |

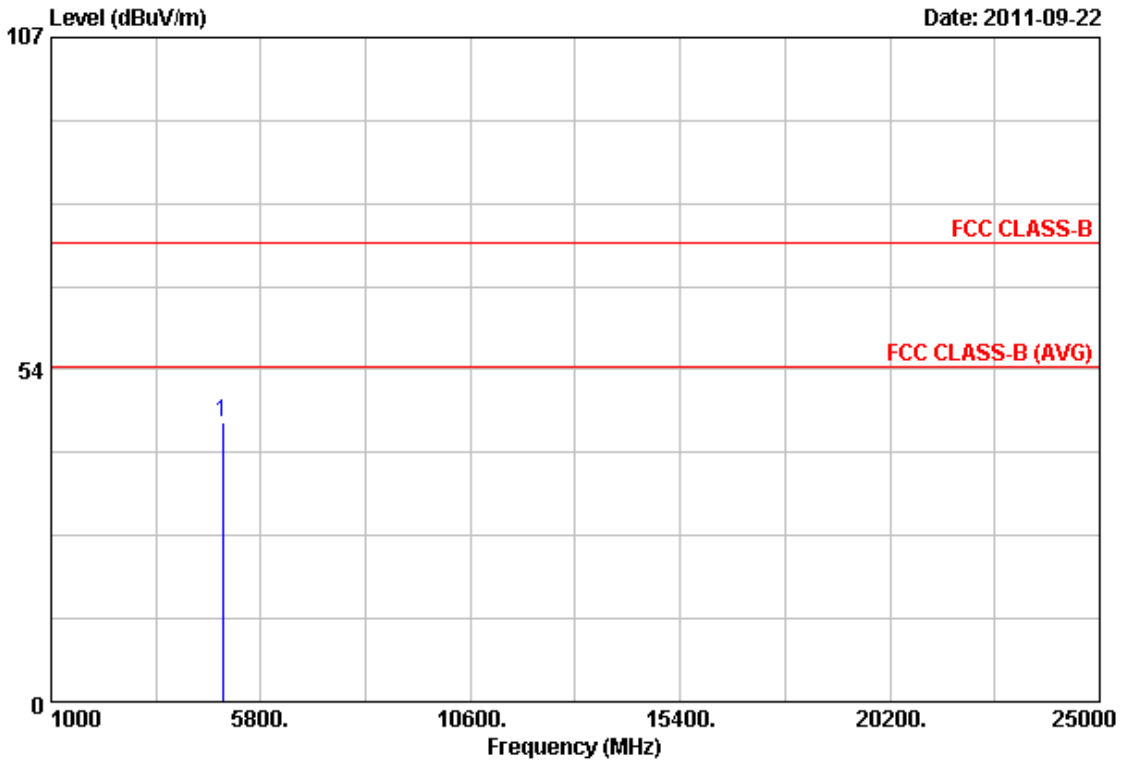

| Item | Freq | Read Value | Factor | Result | Limit | Margin | Remark | Ant Pos | Tab Pos |
|------|---------|------------|--------|--------|--------|--------|--------|---------|---------|
| | MHz | dBuV | dB/m | dBuV/m | dBuV/m | dB | | cm | Deg |
| 1 | 4924.00 | 40.08 | 4.93 | 45.01 | 74.00 | -28.99 | Peak | 100 | 117 |

Notes:

1. Result = Read Value + Factor
2. Factor = Antenna Factor + Cable Loss - Amplifier
3. The resolution bandwidth of test receiver/spectrum analyzer is 120KHz and video bandwidth is 300kHz for Peak detection and Quasi-peak detection at frequency below 1GHz.
4. The resolution bandwidth of test receiver/spectrum analyzer is 1MHz and video bandwidth is 3MHz for Peak detection at frequency above 1GHz.
5. The resolution bandwidth of test receiver/spectrum analyzer is 1MHz and video bandwidth is 10Hz for Average detection at frequency above 1GHz.
6. The other emissions is too low to be measured.
7. The data is worse case.



| | | | |
|-------------|----------------|-------------|------------|
| Power | : AC 120V | Pol/Phase | : VERTICAL |
| Test Mode 1 | : 802.11g, CH1 | Temperature | : 23 °C |
| Memo | : | Humidity | : 65 % |

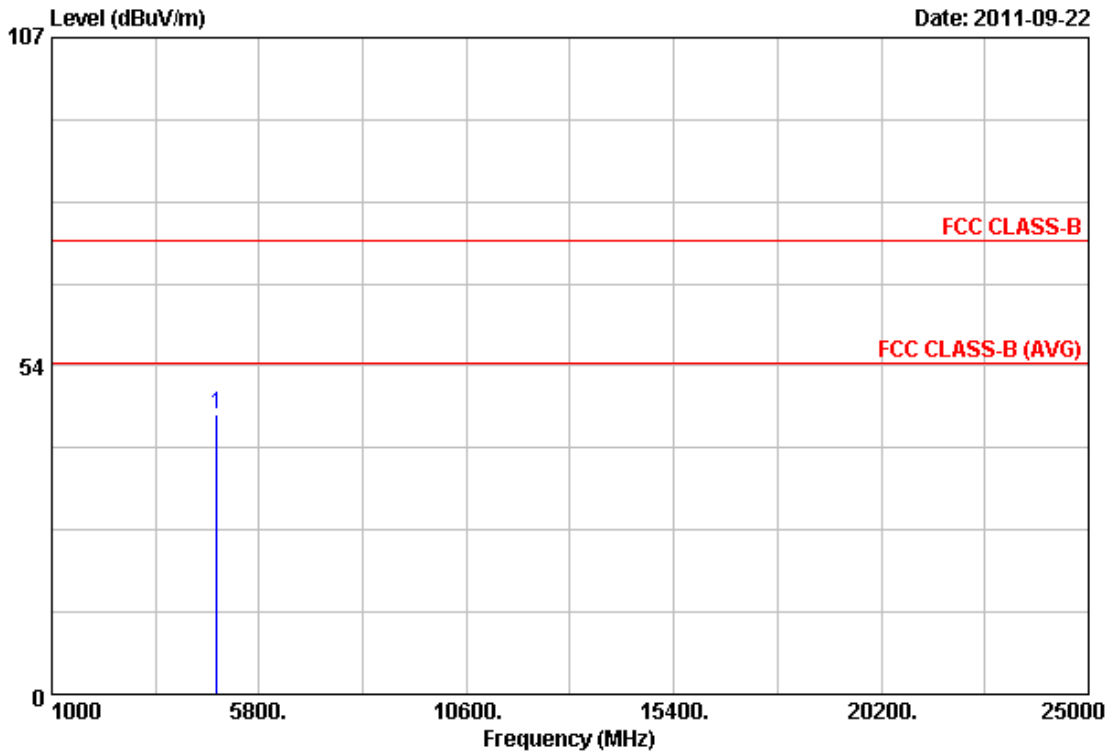

| Item | Freq | Read Value | Factor | Result | Limit | Margin | Remark | Ant Pos | Tab Pos |
|------|---------|------------|--------|--------|--------|--------|--------|---------|---------|
| | MHz | dBuV | dB/m | dBuV/m | dBuV/m | dB | | cm | Deg |
| 1 | 4824.00 | 40.20 | 5.37 | 45.57 | 74.00 | -28.43 | Peak | 100 | 228 |

Notes:

1. Result = Read Value + Factor
2. Factor = Antenna Factor + Cable Loss - Amplifier
3. The resolution bandwidth of test receiver/spectrum analyzer is 120KHz and video bandwidth is 300kHz for Peak detection and Quasi-peak detection at frequency below 1GHz.
4. The resolution bandwidth of test receiver/spectrum analyzer is 1MHz and video bandwidth is 3MHz for Peak detection at frequency above 1GHz.
5. The resolution bandwidth of test receiver/spectrum analyzer is 1MHz and video bandwidth is 10Hz for Average detection at frequency above 1GHz.
6. The other emissions is too low to be measured.
7. The data is worse case.



| | | | |
|-------------|----------------|-------------|--------------|
| Power | : AC 120V | Pol/Phase | : HORIZONTAL |
| Test Mode 1 | : 802.11g, CH1 | Temperature | : 23 °C |
| Memo | : | Humidity | : 65 % |

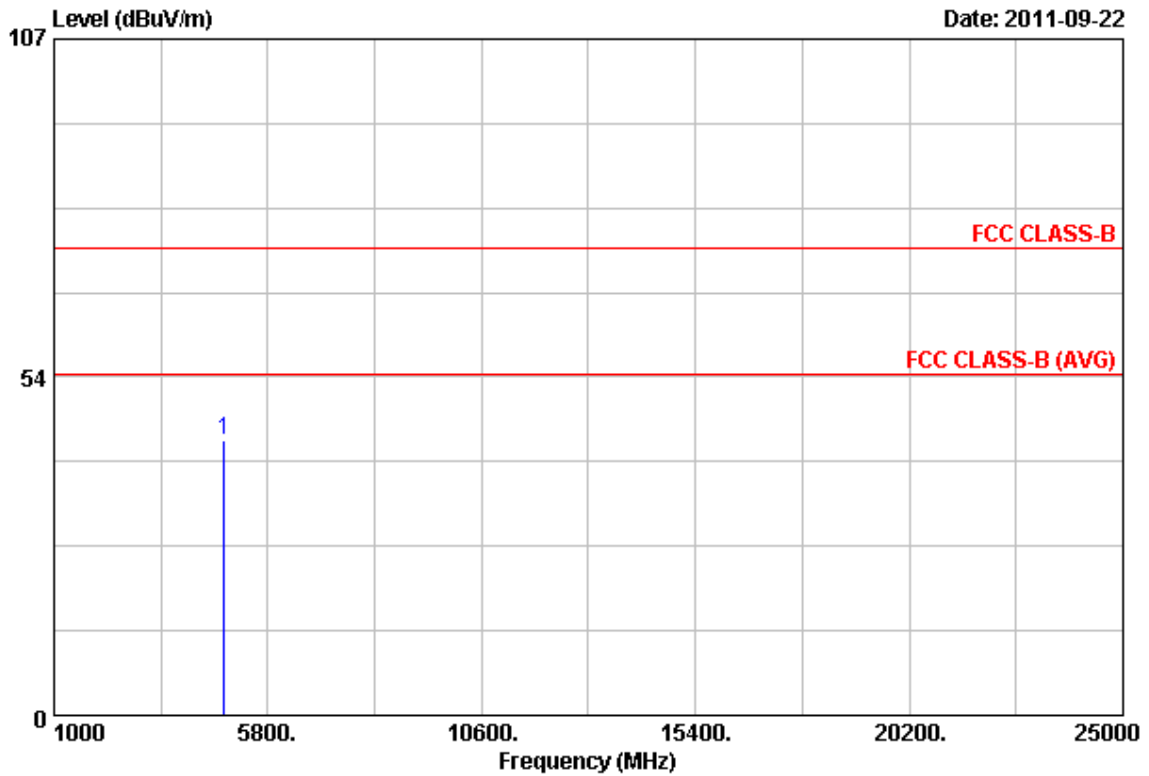

| Item | Freq | Read Value | Factor | Result | Limit | Margin | Remark | Ant Pos | Tab Pos |
|------|---------|------------|--------|--------|--------|--------|--------|---------|---------|
| | MHz | dBuV | dB/m | dBuV/m | dBuV/m | dB | | cm | Deg |
| 1 | 4824.00 | 39.70 | 3.71 | 43.41 | 74.00 | -30.59 | Peak | 100 | 113 |

Notes:

1. Result = Read Value + Factor
2. Factor = Antenna Factor + Cable Loss - Amplifier
3. The resolution bandwidth of test receiver/spectrum analyzer is 120KHz and video bandwidth is 300kHz for Peak detection and Quasi-peak detection at frequency below 1GHz.
4. The resolution bandwidth of test receiver/spectrum analyzer is 1MHz and video bandwidth is 3MHz for Peak detection at frequency above 1GHz.
5. The resolution bandwidth of test receiver/spectrum analyzer is 1MHz and video bandwidth is 10Hz for Average detection at frequency above 1GHz.
6. The other emissions is too low to be measured.
7. The data is worse case.



| | | | |
|-------------|----------------|-------------|------------|
| Power | : AC 120V | Pol/Phase | : VERTICAL |
| Test Mode 1 | : 802.11g, CH6 | Temperature | : 23 °C |
| Memo | : | Humidity | : 65 % |

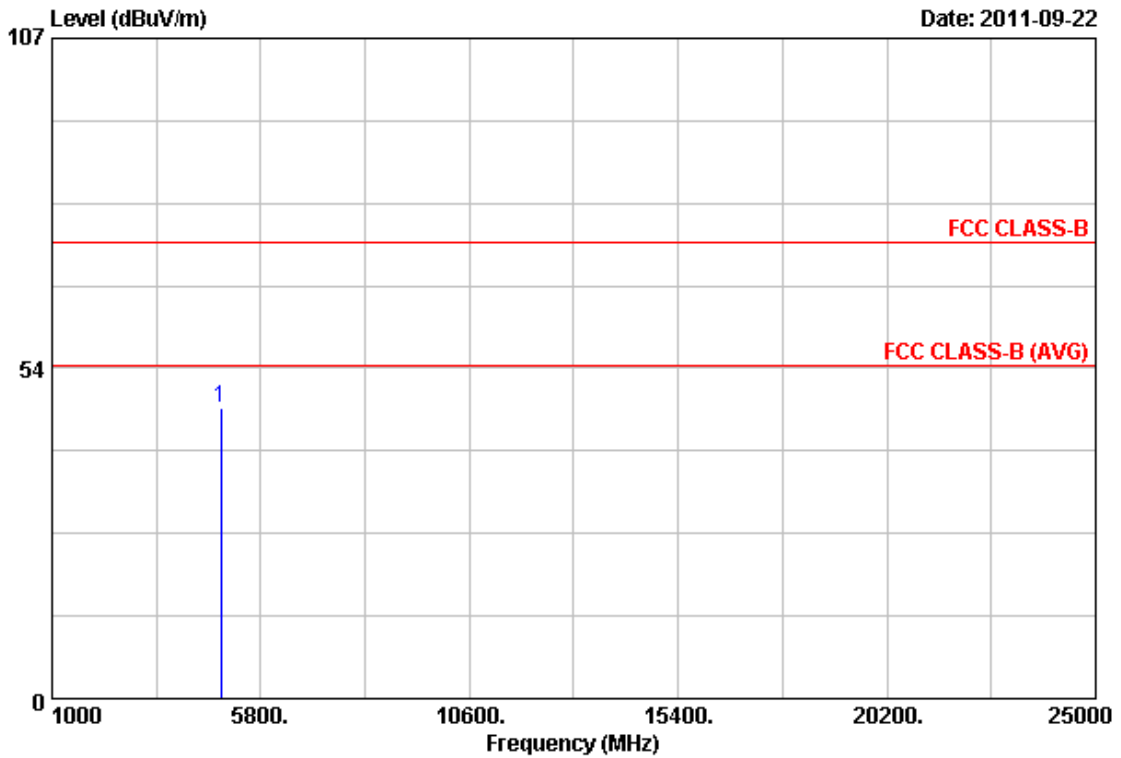

| Item | Freq | Read Value | Factor | Result | Limit | Margin | Remark | Ant Pos | Tab Pos |
|------|---------|------------|--------|--------|--------|--------|--------|---------|---------|
| | MHz | dBuV | dB/m | dBuV/m | dBuV/m | dB | | cm | Deg |
| 1 | 4874.00 | 40.75 | 6.36 | 47.11 | 74.00 | -26.89 | Peak | 100 | 232 |

Notes:

1. Result = Read Value + Factor
2. Factor = Antenna Factor + Cable Loss - Amplifier
3. The resolution bandwidth of test receiver/spectrum analyzer is 120KHz and video bandwidth is 300kHz for Peak detection and Quasi-peak detection at frequency below 1GHz.
4. The resolution bandwidth of test receiver/spectrum analyzer is 1MHz and video bandwidth is 3MHz for Peak detection at frequency above 1GHz.
5. The resolution bandwidth of test receiver/spectrum analyzer is 1MHz and video bandwidth is 10Hz for Average detection at frequency above 1GHz.
6. The other emissions is too low to be measured.
7. The data is worse case.



| | | | |
|-------------|----------------|-------------|--------------|
| Power | : AC 120V | Pol/Phase | : HORIZONTAL |
| Test Mode 1 | : 802.11g, CH6 | Temperature | : 23 °C |
| Memo | : | Humidity | : 65 % |

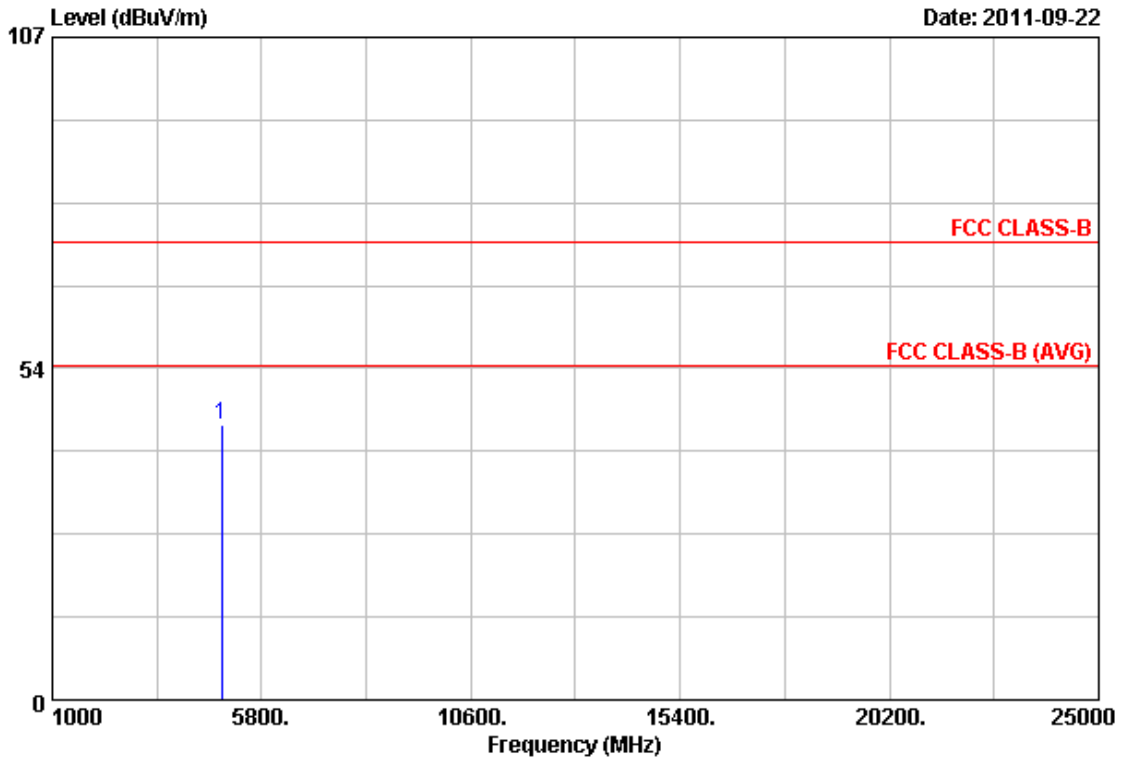

| Item | Freq | Read Value | Factor | Result | Limit | Margin | Remark | Ant Pos | Tab Pos |
|------|---------|------------|--------|--------|--------|--------|--------|---------|---------|
| | MHz | dBuV | dB/m | dBuV/m | dBuV/m | dB | | cm | Deg |
| 1 | 4874.00 | 39.86 | 4.50 | 44.36 | 74.00 | -29.64 | Peak | 100 | 133 |

Notes:

1. Result = Read Value + Factor
2. Factor = Antenna Factor + Cable Loss - Amplifier
3. The resolution bandwidth of test receiver/spectrum analyzer is 120KHz and video bandwidth is 300kHz for Peak detection and Quasi-peak detection at frequency below 1GHz.
4. The resolution bandwidth of test receiver/spectrum analyzer is 1MHz and video bandwidth is 3MHz for Peak detection at frequency above 1GHz.
5. The resolution bandwidth of test receiver/spectrum analyzer is 1MHz and video bandwidth is 10Hz for Average detection at frequency above 1GHz.
6. The other emissions is too low to be measured.
7. The data is worse case.



| | | | |
|-------------|-----------------|-------------|------------|
| Power | : AC 120V | Pol/Phase | : VERTICAL |
| Test Mode 1 | : 802.11g, CH11 | Temperature | : 23 °C |
| Memo | : | Humidity | : 65 % |

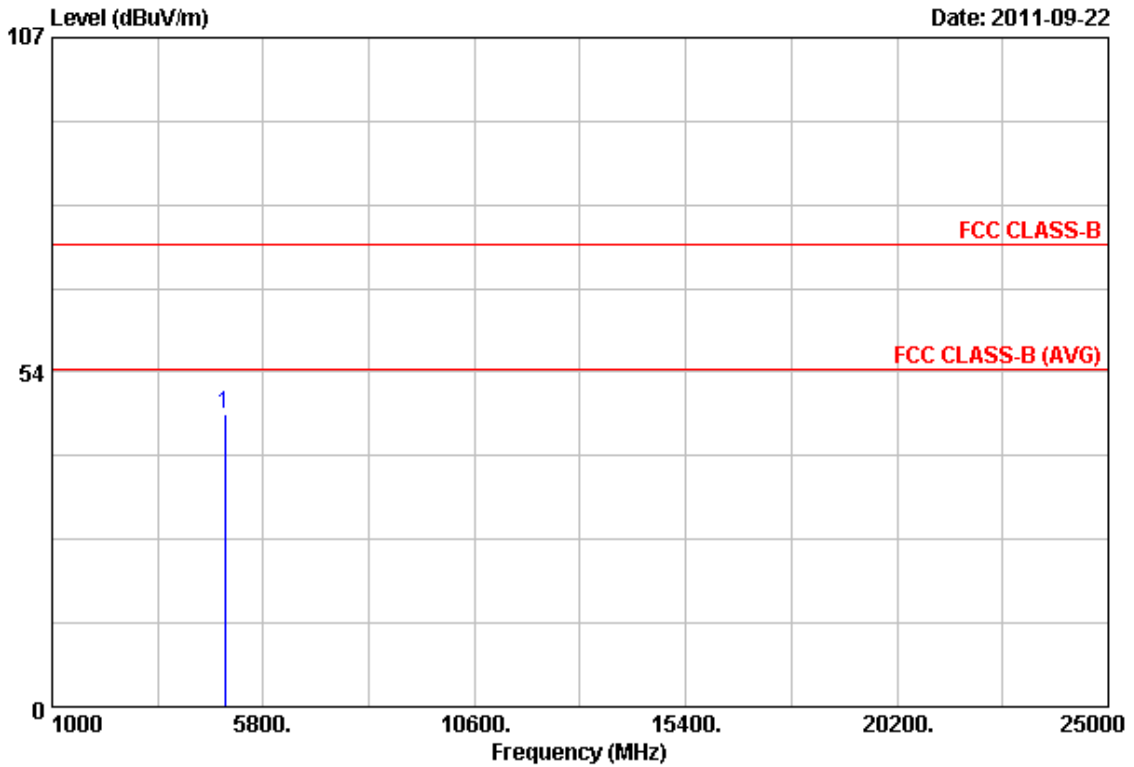

| Item | Freq | Read Value | Factor | Result | Limit | Margin | Remark | Ant Pos | Tab Pos |
|------|---------|------------|--------|--------|--------|--------|--------|---------|---------|
| | MHz | dBuV | dB/m | dBuV/m | dBuV/m | dB | | cm | Deg |
| 1 | 4924.00 | 39.78 | 6.94 | 46.72 | 74.00 | -27.28 | Peak | 100 | 225 |

Notes:

1. Result = Read Value + Factor
2. Factor = Antenna Factor + Cable Loss - Amplifier
3. The resolution bandwidth of test receiver/spectrum analyzer is 120KHz and video bandwidth is 300kHz for Peak detection and Quasi-peak detection at frequency below 1GHz.
4. The resolution bandwidth of test receiver/spectrum analyzer is 1MHz and video bandwidth is 3MHz for Peak detection at frequency above 1GHz.
5. The resolution bandwidth of test receiver/spectrum analyzer is 1MHz and video bandwidth is 10Hz for Average detection at frequency above 1GHz.
6. The other emissions is too low to be measured.
7. The data is worse case.



| | | | |
|-------------|-----------------|-------------|--------------|
| Power | : AC 120V | Pol/Phase | : HORIZONTAL |
| Test Mode 1 | : 802.11g, CH11 | Temperature | : 23 °C |
| Memo | : | Humidity | : 65 % |

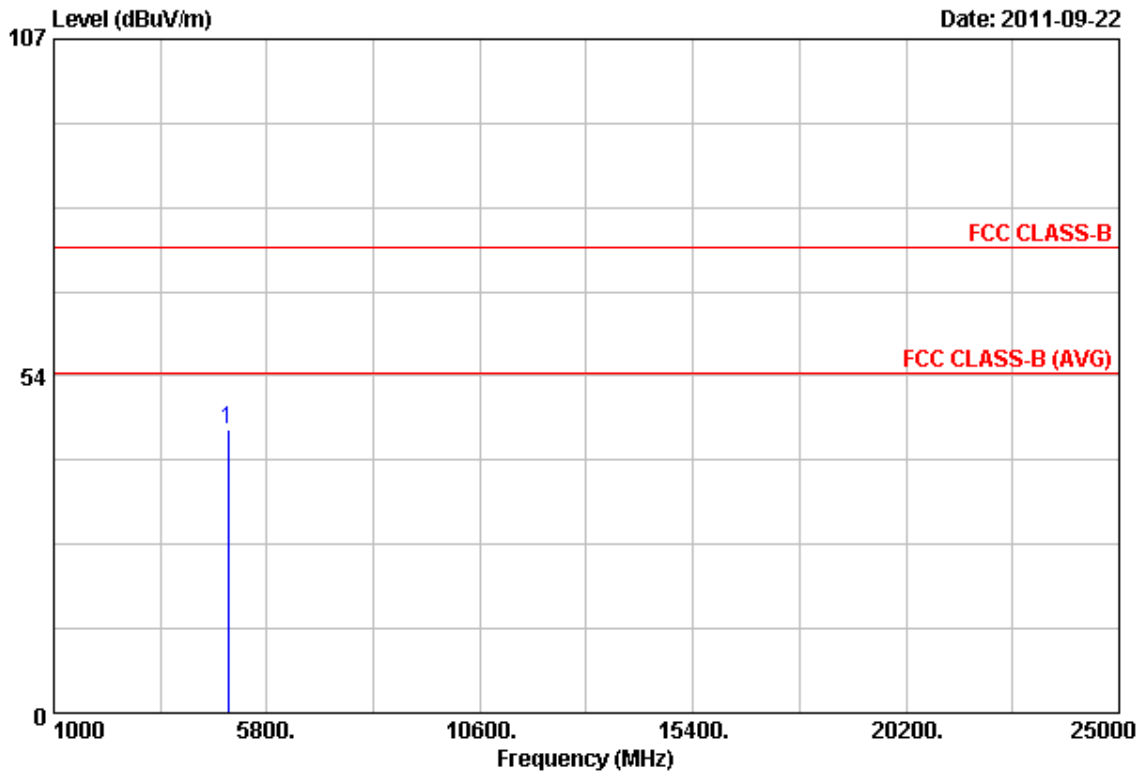

| Item | Freq | Read Value | Factor | Result | Limit | Margin | Remark | Ant Pos | Tab Pos |
|------|---------|------------|--------|--------|--------|--------|--------|---------|---------|
| | MHz | dBuV | dB/m | dBuV/m | dBuV/m | dB | | cm | Deg |
| 1 | 4924.00 | 39.98 | 4.93 | 44.91 | 74.00 | -29.09 | Peak | 100 | 121 |

Notes:

1. Result = Read Value + Factor
2. Factor = Antenna Factor + Cable Loss - Amplifier
3. The resolution bandwidth of test receiver/spectrum analyzer is 120KHz and video bandwidth is 300KHz for Peak detection and Quasi-peak detection at frequency below 1GHz.
4. The resolution bandwidth of test receiver/spectrum analyzer is 1MHz and video bandwidth is 3MHz for Peak detection at frequency above 1GHz.
5. The resolution bandwidth of test receiver/spectrum analyzer is 1MHz and video bandwidth is 10Hz for Average detection at frequency above 1GHz.
6. The other emissions is too low to be measured.
7. The data is worse case.



| | | | |
|-------------|---------------------|------------|------------|
| Power | : AC 120V | Pol/Phase | : VERTICAL |
| Test Mode 2 | : 802.11n HT20, CH1 | Temperatur | : 23 °C |
| Memo | : | Humidity | : 65 % |

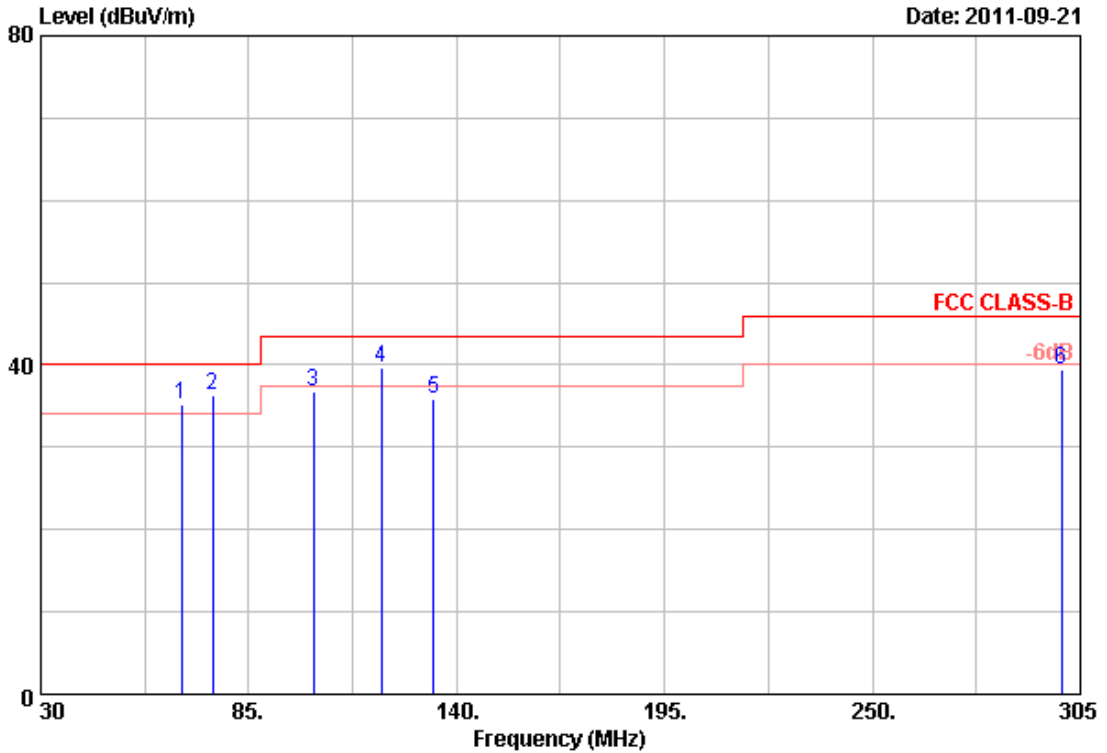

| Item | Freq | Read Value | Factor | Result | Limit | Margin | Remark | Ant Pos | Tab Pos |
|------|--------|------------|--------|--------|--------|--------|--------|---------|---------|
| | MHz | dBuV | dB/m | dBuV/m | dBuV/m | dB | | cm | Deg |
| 1 | 67.13 | 43.44 | -8.16 | 35.28 | 40.00 | -4.72 | QP | 100 | 360 |
| 2 | 75.38 | 42.28 | -6.00 | 36.28 | 40.00 | -3.72 | QP | 100 | 360 |
| 3 | 102.05 | 36.29 | 0.38 | 36.67 | 43.50 | -6.83 | Peak | 100 | 360 |
| 4 | 120.20 | 31.83 | 7.80 | 39.63 | 43.50 | -3.87 | QP | 100 | 360 |
| 5 | 133.95 | 35.34 | 0.43 | 35.77 | 43.50 | -7.73 | Peak | 100 | 360 |
| 6 | 300.05 | 43.51 | -4.15 | 39.36 | 46.00 | -6.64 | Peak | 100 | 360 |

Notes:

1. Result = Read Value + Factor
2. Factor = Antenna Factor + Cable Loss - Amplifier
3. The resolution bandwidth of test receiver/spectrum analyzer is 120KHz and video bandwidth is 300kHz for Peak detection and Quasi-peak detection at frequency below 1GHz.
4. All emission below 1GHz at 802.11b/g/n mode are all the same,so the 802.11g/n mode chosen as representative in final test.
5. According to technical experiences,all spurious emission of 802.11g/n mode at channel 1,6,11 or 3,6,9(for HT40) are almost the same below 1GHz,so that the channel 1 or 3(for HT40)was chosen as representative in final test.
6. The data is worse case.



| | | | |
|-------------|---------------------|-------------|------------|
| Power | : AC 120V | Pol/Phase | : VERTICAL |
| Test Mode 2 | : 802.11n HT20, CH1 | Temperature | : 23 °C |
| Memo | : | Humidity | : 65 % |

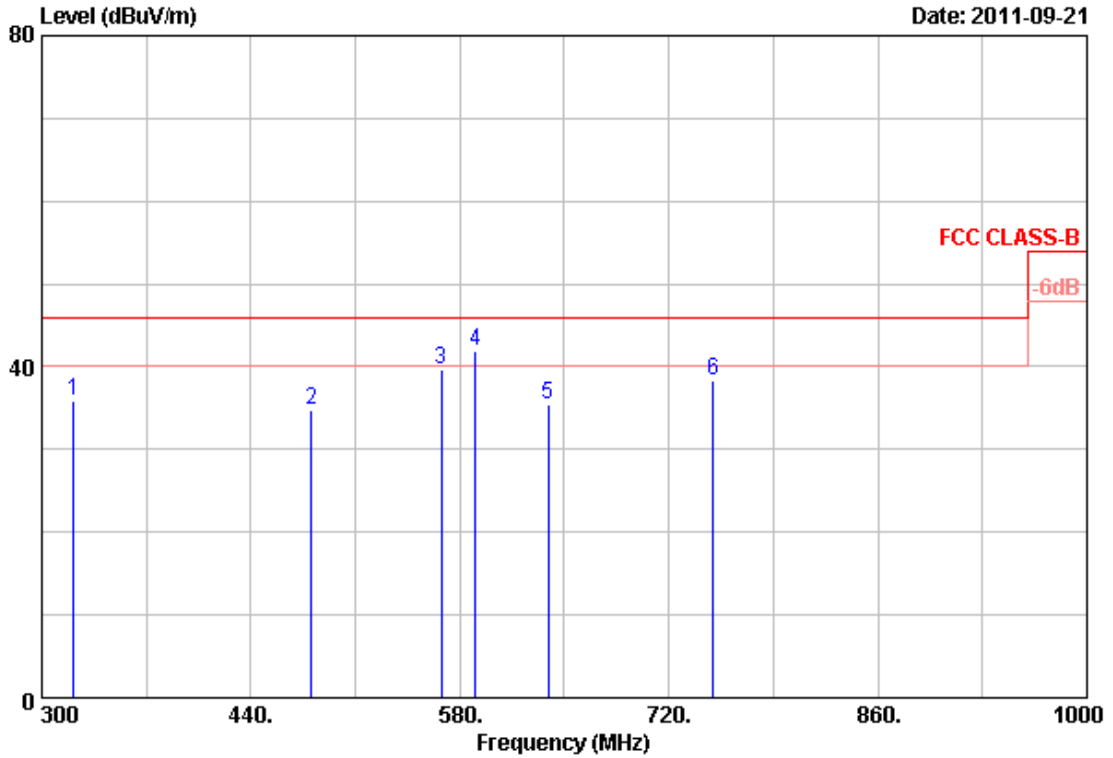

| Item | Freq | Read Value | Factor | Result | Limit | Margin | Remark | Ant Pos | Tab Pos |
|------|--------|------------|--------|--------|--------|--------|--------|---------|---------|
| | MHz | dBuV | dB/m | dBuV/m | dBuV/m | dB | | cm | Deg |
| 1 | 321.00 | 39.91 | -4.14 | 35.77 | 46.00 | -10.23 | Peak | 100 | 0 |
| 2 | 480.60 | 35.49 | -0.65 | 34.84 | 46.00 | -11.16 | Peak | 100 | 0 |
| 3 | 567.40 | 30.66 | 8.98 | 39.64 | 46.00 | -6.36 | Peak | 100 | 0 |
| 4 | 590.50 | 35.56 | 6.33 | 41.89 | 46.00 | -4.11 | QP | 100 | 0 |
| 5 | 639.50 | 31.89 | 3.46 | 35.35 | 46.00 | -10.65 | Peak | 100 | 0 |
| 6 | 749.40 | 30.20 | 8.23 | 38.43 | 46.00 | -7.57 | Peak | 100 | 0 |

Notes:

1. Result = Read Value + Factor
2. Factor = Antenna Factor + Cable Loss - Amplifier
3. The resolution bandwidth of test receiver/spectrum analyzer is 120KHz and video bandwidth is 300kHz for Peak detection and Quasi-peak detection at frequency below 1GHz.
4. All emission below 1GHz at 802.11b/g/n mode are all the same,so the 802.11g/n mode chosen as representative in final test.
5. According to technical experiences,all spurious emission of 802.11g/n mode at channel 1,6,11 or 3,6,9(for HT40) are almost the same below 1GHz,so that the channel 1 or 3(for HT40)was chosen as representative in final test.
6. The data is worse case.



| | | | |
|-------------|---------------------|-------------|--------------|
| Power | : AC 120V | Pol/Phase | : HORIZONTAL |
| Test Mode 2 | : 802.11n HT20, CH1 | Temperature | : 23 °C |
| Memo | : | Humidity | : 65 % |

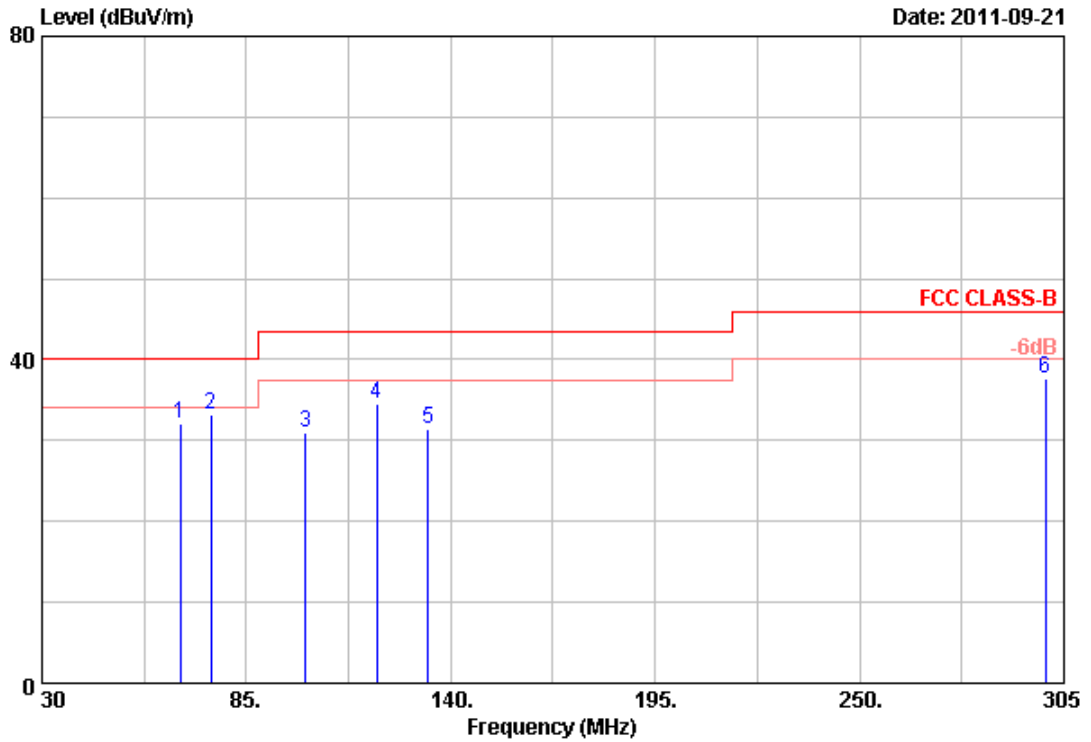

| Item | Freq | Read Value | Factor | Result | Limit | Margin | Remark | Ant Pos | Tab Pos |
|------|--------|------------|--------|--------|--------|--------|--------|---------|---------|
| | MHz | dBuV | dB/m | dBuV/m | dBuV/m | dB | | cm | Deg |
| 1 | 67.13 | 47.77 | -15.64 | 32.13 | 40.00 | -7.87 | Peak | 100 | 360 |
| 2 | 75.38 | 47.88 | -14.67 | 33.21 | 40.00 | -6.79 | Peak | 100 | 360 |
| 3 | 100.95 | 39.87 | -8.91 | 30.96 | 43.50 | -12.54 | Peak | 100 | 360 |
| 4 | 120.20 | 44.87 | -10.27 | 34.60 | 43.50 | -8.90 | Peak | 100 | 360 |
| 5 | 133.95 | 41.05 | -9.64 | 31.41 | 43.50 | -12.09 | Peak | 100 | 360 |
| 6 | 300.05 | 43.78 | -6.07 | 37.71 | 46.00 | -8.29 | Peak | 100 | 360 |

Notes:

1. Result = Read Value + Factor
2. Factor = Antenna Factor + Cable Loss - Amplifier
3. The resolution bandwidth of test receiver/spectrum analyzer is 120KHz and video bandwidth is 300kHz for Peak detection and Quasi-peak detection at frequency below 1GHz.
4. All emission below 1GHz at 802.11b/g/n mode are all the same,so the 802.11g/n mode chosen as representative in final test.
5. According to technical experiences,all spurious emission of 802.11g/n mode at channel 1,6,11 or 3,6,9(for HT40) are almost the same below 1GHz,so that the channel 1 or 3(for HT40)was chosen as representative in final test.
6. The data is worse case.



| | | | |
|-------------|---------------------|-------------|--------------|
| Power | : AC 120V | Pol/Phase | : HORIZONTAL |
| Test Mode 2 | : 802.11n HT20, CH1 | Temperature | : 23 °C |
| Memo | : | Humidity | : 65 % |

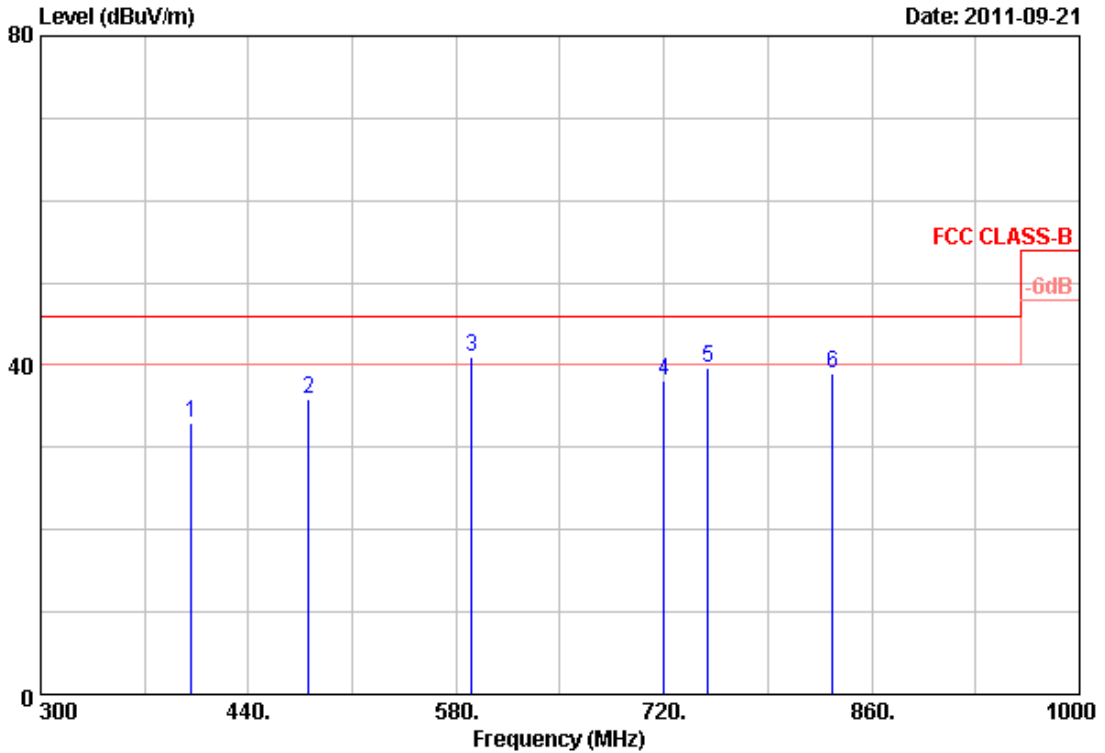

| Item | Freq | Read Value | Factor | Result | Limit | Margin | Remark | Ant Pos | Tab Pos |
|------|--------|------------|--------|--------|--------|--------|--------|---------|---------|
| | MHz | dBuV | dB/m | dBuV/m | dBuV/m | dB | | cm | Deg |
| 1 | 401.50 | 33.12 | -0.17 | 32.95 | 46.00 | -13.05 | Peak | 100 | 0 |
| 2 | 480.60 | 33.28 | 2.56 | 35.84 | 46.00 | -10.16 | Peak | 100 | 0 |
| 3 | 590.50 | 32.79 | 8.31 | 41.10 | 46.00 | -4.90 | QP | 100 | 0 |
| 4 | 720.00 | 32.77 | 5.32 | 38.09 | 46.00 | -7.91 | Peak | 100 | 0 |
| 5 | 749.40 | 31.93 | 7.75 | 39.68 | 46.00 | -6.32 | Peak | 100 | 0 |
| 6 | 833.40 | 25.22 | 13.72 | 38.94 | 46.00 | -7.06 | Peak | 100 | 0 |

Notes:

1. Result = Read Value + Factor
2. Factor = Antenna Factor + Cable Loss - Amplifier
3. The resolution bandwidth of test receiver/spectrum analyzer is 120KHz and video bandwidth is 300kHz for Peak detection and Quasi-peak detection at frequency below 1GHz.
4. All emission below 1GHz at 802.11b/g/n mode are all the same,so the 802.11g/n mode chosen as representative in final test.
5. According to technical experiences,all spurious emission of 802.11g/n mode at channel 1,6,11 or 3,6,9(for HT40) are almost the same below 1GHz,so that the channel 1 or 3(for HT40)was chosen as representative in final test.
6. The data is worse case.



| | | | |
|-------------|---------------------|-------------|------------|
| Power | : AC 120V | Pol/Phase | : VERTICAL |
| Test Mode 2 | : 802.11n HT20, CH1 | Temperature | : 23 °C |
| Memo | : | Humidity | : 65 % |

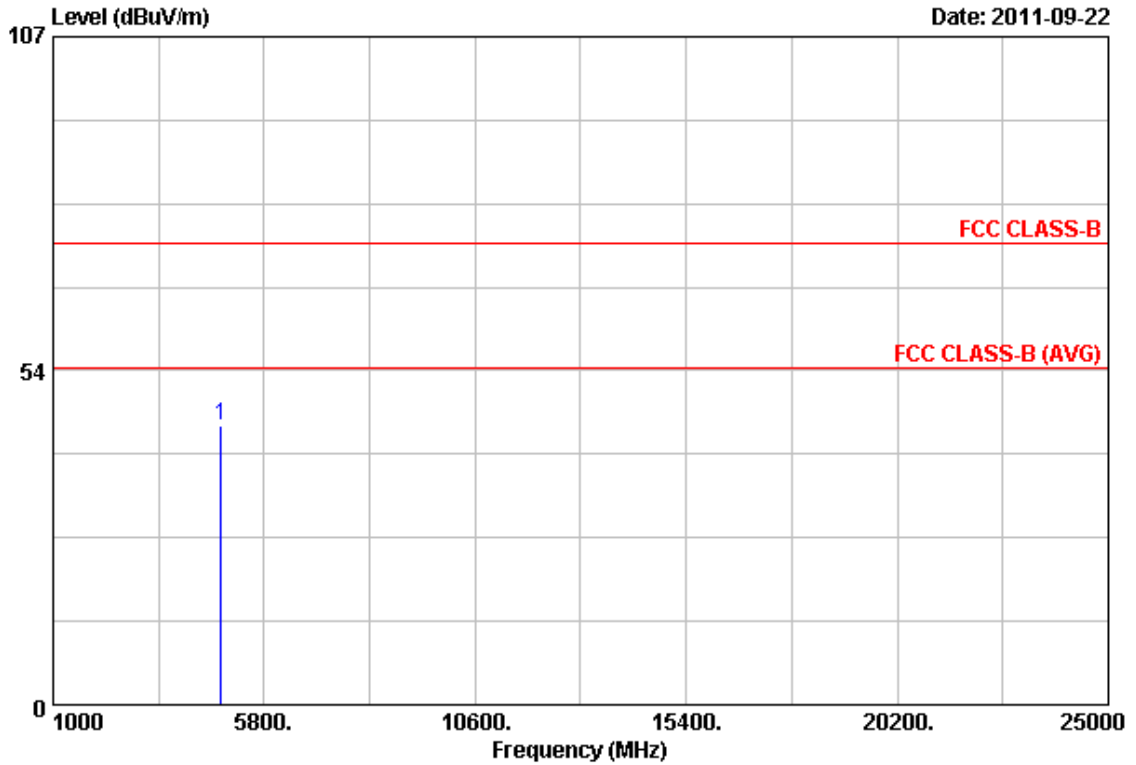

| Item | Freq | Read Value | Factor | Result | Limit | Margin | Remark | Ant Pos | Tab Pos |
|------|---------|------------|--------|--------|--------|--------|--------|---------|---------|
| | MHz | dBuV | dB/m | dBuV/m | dBuV/m | dB | | cm | Deg |
| 1 | 4824.00 | 39.41 | 5.37 | 44.78 | 74.00 | -29.22 | Peak | 100 | 184 |

Notes:

1. Result = Read Value + Factor
2. Factor = Antenna Factor + Cable Loss - Amplifier
3. The resolution bandwidth of test receiver/spectrum analyzer is 120KHz and video bandwidth is 300kHz for Peak detection and Quasi-peak detection at frequency below 1GHz.
4. The resolution bandwidth of test receiver/spectrum analyzer is 1MHz and video bandwidth is 3MHz for Peak detection at frequency above 1GHz.
5. The resolution bandwidth of test receiver/spectrum analyzer is 1MHz and video bandwidth is 10Hz for Average detection at frequency above 1GHz.
6. The other emissions is too low to be measured.
7. The data is worse case.



| | | | |
|-------------|---------------------|-------------|--------------|
| Power | : AC 120V | Pol/Phase | : HORIZONTAL |
| Test Mode 2 | : 802.11n HT20, CH1 | Temperature | : 23 °C |
| Memo | : | Humidity | : 65 % |

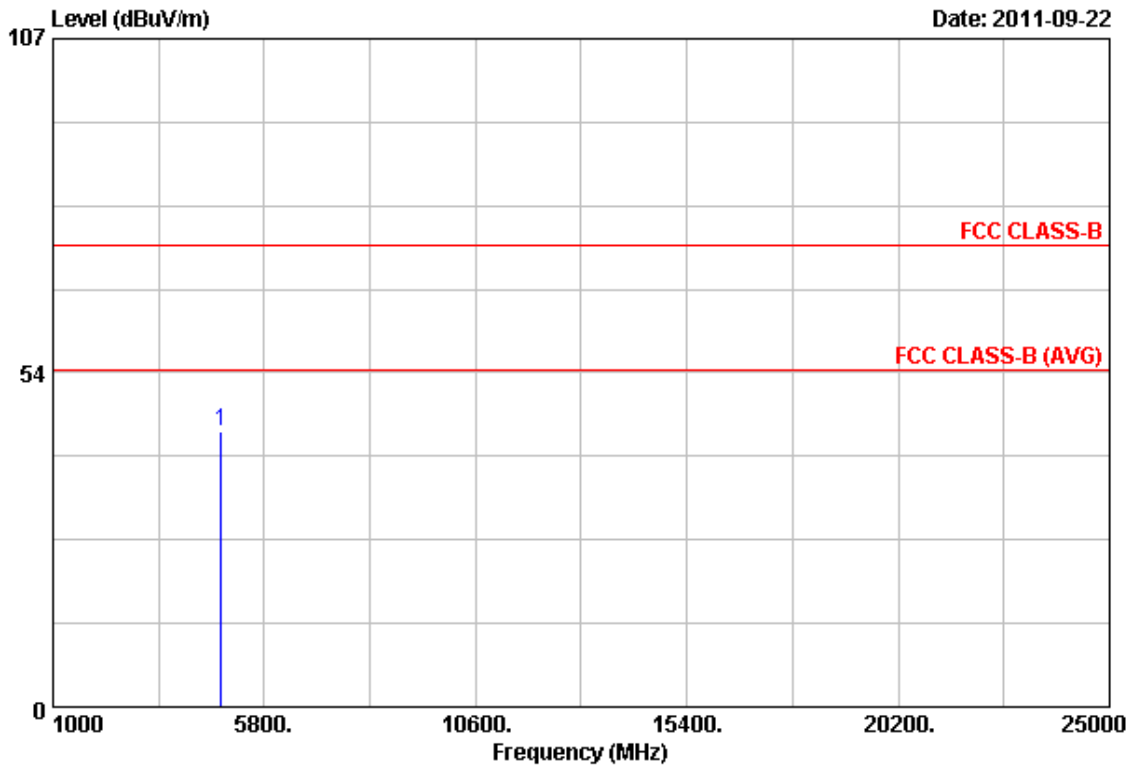

| Item | Freq | Read Value | Factor | Result | Limit | Margin | Remark | Ant Pos | Tab Pos |
|------|---------|------------|--------|--------|--------|--------|--------|---------|---------|
| | MHz | dBuV | dB/m | dBuV/m | dBuV/m | dB | | cm | Deg |
| 1 | 4824.00 | 40.32 | 3.71 | 44.03 | 74.00 | -29.97 | Peak | 100 | 176 |

Notes:

1. Result = Read Value + Factor
2. Factor = Antenna Factor + Cable Loss - Amplifier
3. The resolution bandwidth of test receiver/spectrum analyzer is 120KHz and video bandwidth is 300kHz for Peak detection and Quasi-peak detection at frequency below 1GHz.
4. The resolution bandwidth of test receiver/spectrum analyzer is 1MHz and video bandwidth is 3MHz for Peak detection at frequency above 1GHz.
5. The resolution bandwidth of test receiver/spectrum analyzer is 1MHz and video bandwidth is 10Hz for Average detection at frequency above 1GHz.
6. The other emissions is too low to be measured.
7. The data is worse case.



| | | | |
|-------------|---------------------|-------------|------------|
| Power | : AC 120V | Pol/Phase | : VERTICAL |
| Test Mode 2 | : 802.11n HT20, CH6 | Temperature | : 23 °C |
| Memo | : | Humidity | : 65 % |

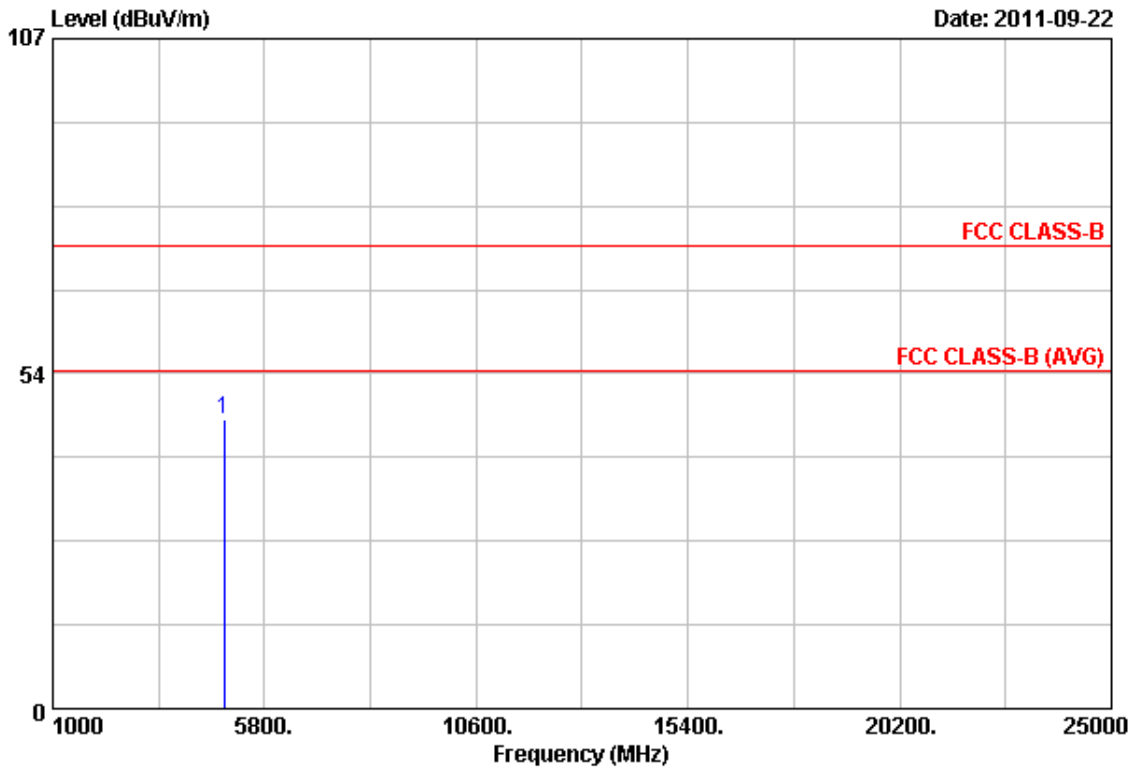

| Item | Freq | Read Value | Factor | Result | Limit | Margin | Remark | Ant Pos | Tab Pos |
|------|---------|------------|--------|--------|--------|--------|--------|---------|---------|
| | MHz | dBuV | dB/m | dBuV/m | dBuV/m | dB | | cm | Deg |
| 1 | 4874.00 | 39.86 | 6.36 | 46.22 | 74.00 | -27.78 | Peak | 100 | 176 |

Notes:

1. Result = Read Value + Factor
2. Factor = Antenna Factor + Cable Loss - Amplifier
3. The resolution bandwidth of test receiver/spectrum analyzer is 120KHz and video bandwidth is 300kHz for Peak detection and Quasi-peak detection at frequency below 1GHz.
4. The resolution bandwidth of test receiver/spectrum analyzer is 1MHz and video bandwidth is 3MHz for Peak detection at frequency above 1GHz.
5. The resolution bandwidth of test receiver/spectrum analyzer is 1MHz and video bandwidth is 10Hz for Average detection at frequency above 1GHz.
6. The other emissions is too low to be measured.
7. The data is worse case.



| | | | |
|-------------|---------------------|-------------|--------------|
| Power | : AC 120V | Pol/Phase | : HORIZONTAL |
| Test Mode 2 | : 802.11n HT20, CH6 | Temperature | : 23 °C |
| Memo | : | Humidity | : 65 % |

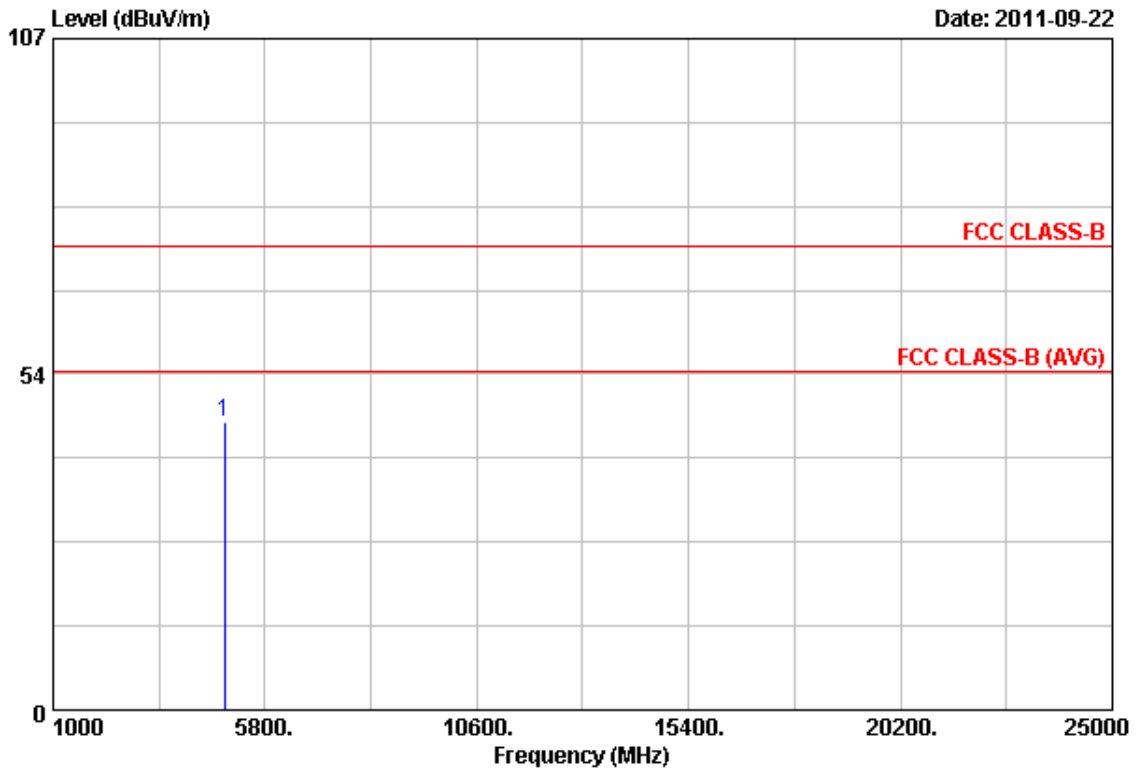

| Item | Freq | Read Value | Factor | Result | Limit | Margin | Remark | Ant Pos | Tab Pos |
|------|---------|------------|--------|--------|--------|--------|--------|---------|---------|
| | MHz | dBuV | dB/m | dBuV/m | dBuV/m | dB | | cm | Deg |
| 1 | 4874.00 | 41.38 | 4.50 | 45.88 | 74.00 | -28.12 | Peak | 100 | 161 |

Notes:

1. Result = Read Value + Factor
2. Factor = Antenna Factor + Cable Loss - Amplifier
3. The resolution bandwidth of test receiver/spectrum analyzer is 120KHz and video bandwidth is 300KHz for Peak detection and Quasi-peak detection at frequency below 1GHz.
4. The resolution bandwidth of test receiver/spectrum analyzer is 1MHz and video bandwidth is 3MHz for Peak detection at frequency above 1GHz.
5. The resolution bandwidth of test receiver/spectrum analyzer is 1MHz and video bandwidth is 10Hz for Average detection at frequency above 1GHz.
6. The other emissions is too low to be measured.
7. The data is worse case.



| | | | |
|-------------|----------------------|-------------|------------|
| Power | : AC 120V | Pol/Phase | : VERTICAL |
| Test Mode 2 | : 802.11n HT20, CH11 | Temperature | : 23 °C |
| Memo | : | Humidity | : 65 % |

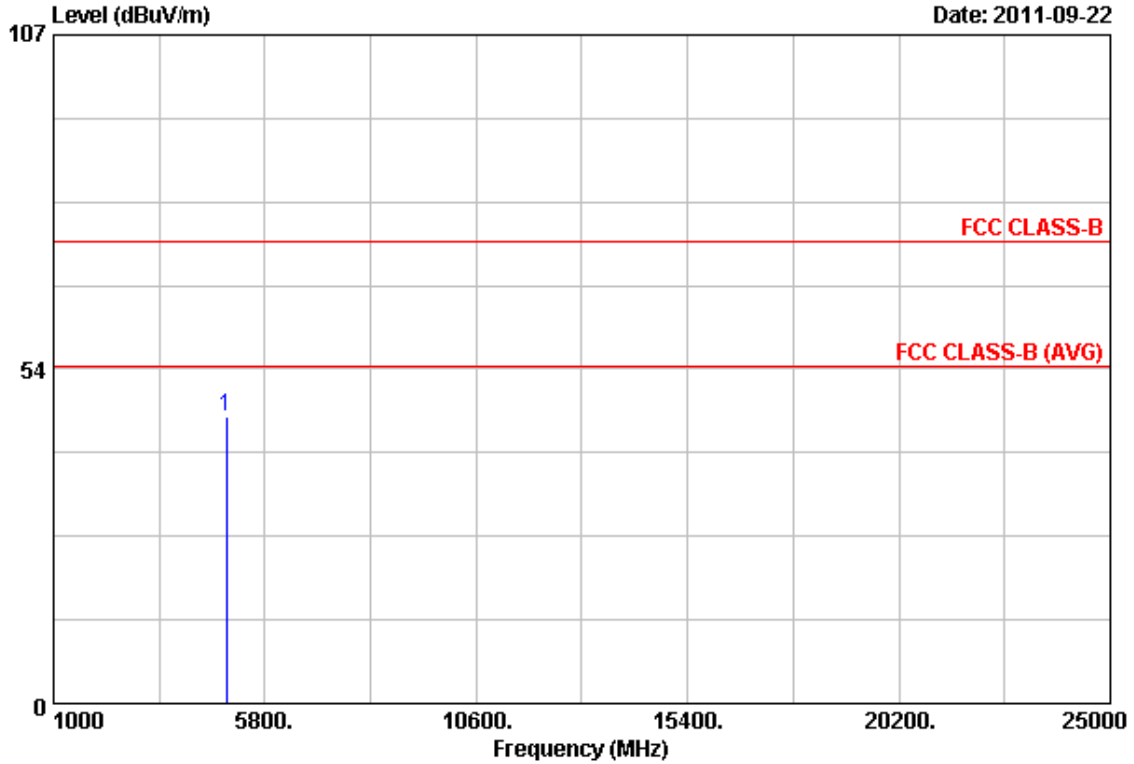

| Item | Freq | Read Value | Factor | Result | Limit | Margin | Remark | Ant Pos | Tab Pos |
|------|---------|------------|--------|--------|--------|--------|--------|---------|---------|
| | MHz | dBuV | dB/m | dBuV/m | dBuV/m | dB | | cm | Deg |
| 1 | 4924.00 | 38.84 | 6.94 | 45.78 | 74.00 | -28.22 | Peak | 100 | 161 |

Notes:

1. Result = Read Value + Factor
2. Factor = Antenna Factor + Cable Loss - Amplifier
3. The resolution bandwidth of test receiver/spectrum analyzer is 120KHz and video bandwidth is 300kHz for Peak detection and Quasi-peak detection at frequency below 1GHz.
4. The resolution bandwidth of test receiver/spectrum analyzer is 1MHz and video bandwidth is 3MHz for Peak detection at frequency above 1GHz.
5. The resolution bandwidth of test receiver/spectrum analyzer is 1MHz and video bandwidth is 10Hz for Average detection at frequency above 1GHz.
6. The other emissions is too low to be measured.
7. The data is worse case.



| | | | |
|-------------|----------------------|-------------|--------------|
| Power | : AC 120V | Pol/Phase | : HORIZONTAL |
| Test Mode 2 | : 802.11n HT20, CH11 | Temperature | : 23 °C |
| Memo | : | Humidity | : 65 % |

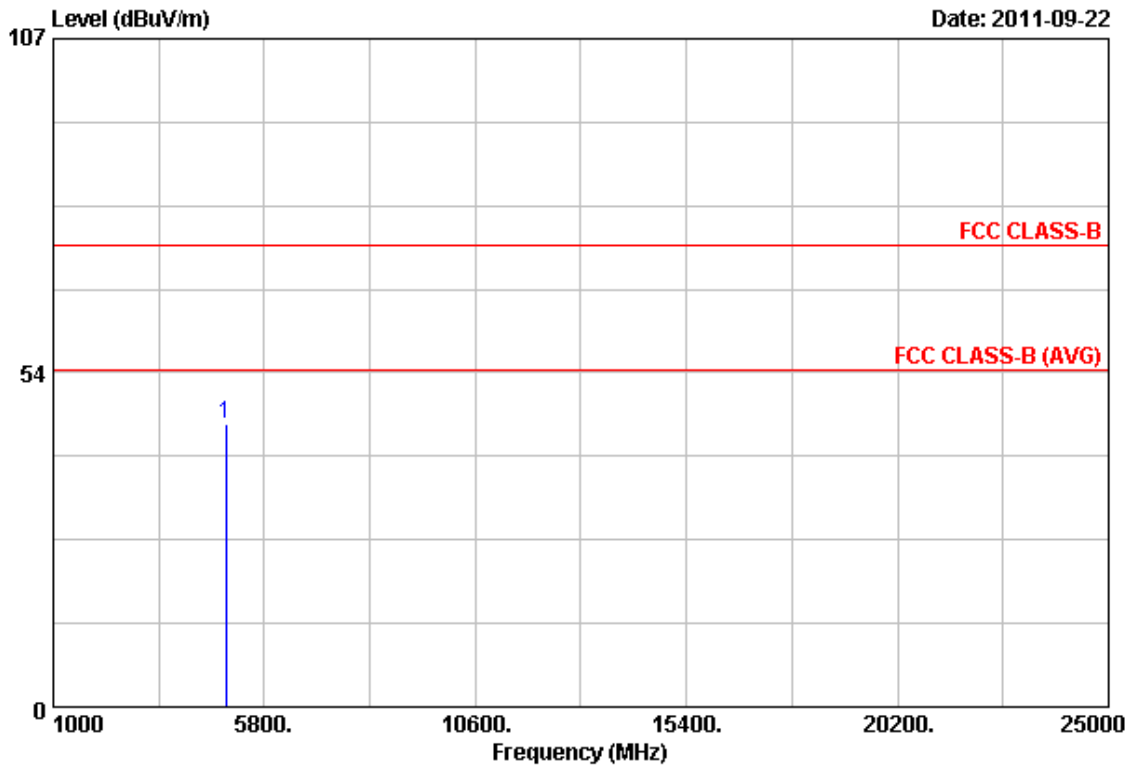

| Item | Freq | Read Value | Factor | Result | Limit | Margin | Remark | Ant Pos | Tab Pos |
|------|---------|------------|--------|--------|--------|--------|--------|---------|---------|
| | MHz | dBuV | dB/m | dBuV/m | dBuV/m | dB | | cm | Deg |
| 1 | 4924.00 | 40.39 | 4.93 | 45.32 | 74.00 | -28.68 | Peak | 100 | 187 |

Notes:

1. Result = Read Value + Factor
2. Factor = Antenna Factor + Cable Loss - Amplifier
3. The resolution bandwidth of test receiver/spectrum analyzer is 120KHz and video bandwidth is 300KHz for Peak detection and Quasi-peak detection at frequency below 1GHz.
4. The resolution bandwidth of test receiver/spectrum analyzer is 1MHz and video bandwidth is 3MHz for Peak detection at frequency above 1GHz.
5. The resolution bandwidth of test receiver/spectrum analyzer is 1MHz and video bandwidth is 10Hz for Average detection at frequency above 1GHz.
6. The other emissions is too low to be measured.
7. The data is worse case.



| | | | |
|-------------|---------------------|-------------|------------|
| Power | : AC 120V | Pol/Phase | : VERTICAL |
| Test Mode 3 | : 802.11n HT40, CH3 | Temperature | : 23 °C |
| Memo | : | Humidity | : 65 % |

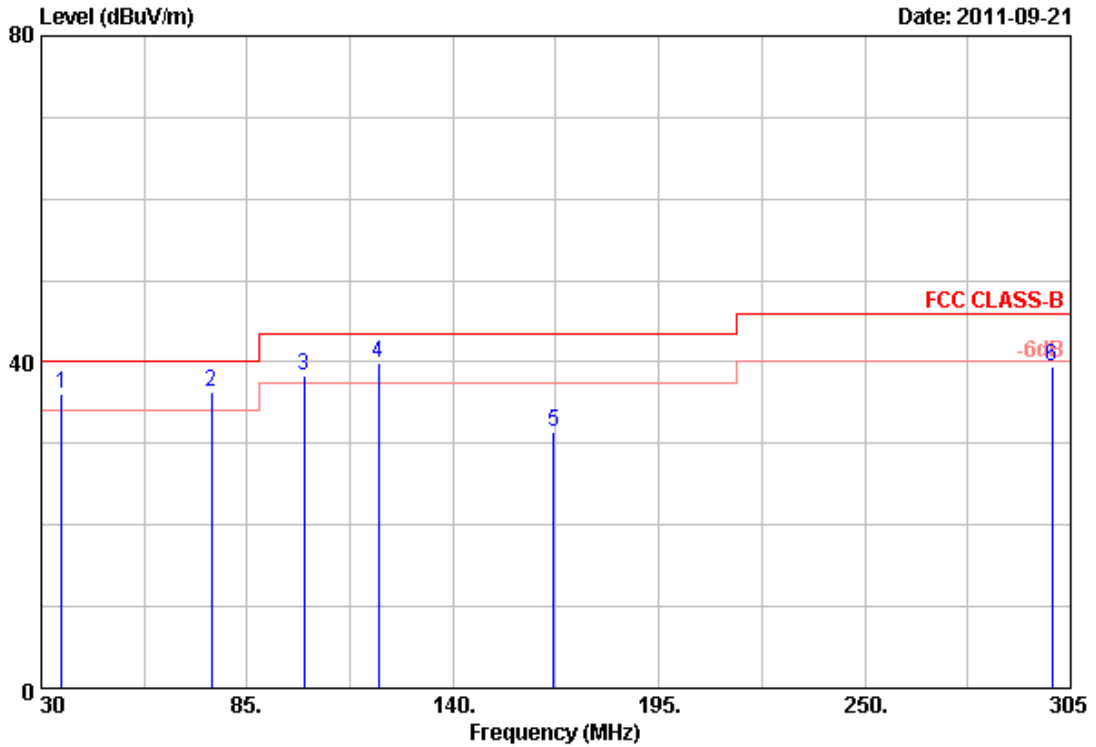

| Item | Freq | Read Value | Factor | Result | Limit | Margin | Remark | Ant Pos | Tab Pos |
|------|--------|------------|--------|--------|--------|--------|--------|---------|---------|
| | MHz | dBuV | dB/m | dBuV/m | dBuV/m | dB | | cm | Deg |
| 1 | 35.50 | 29.81 | 6.25 | 36.06 | 40.00 | -3.94 | QP | 100 | 360 |
| 2 | 75.38 | 42.28 | -6.00 | 36.28 | 40.00 | -3.72 | QP | 100 | 360 |
| 3 | 100.13 | 37.40 | 0.84 | 38.24 | 43.50 | -5.26 | QP | 100 | 360 |
| 4 | 120.20 | 31.99 | 7.80 | 39.79 | 43.50 | -3.71 | QP | 100 | 360 |
| 5 | 166.95 | 32.96 | -1.45 | 31.51 | 43.50 | -11.99 | Peak | 100 | 360 |
| 6 | 300.05 | 43.68 | -4.15 | 39.53 | 46.00 | -6.47 | Peak | 100 | 360 |

Notes:

1. Result = Read Value + Factor
2. Factor = Antenna Factor + Cable Loss - Amplifier
3. The resolution bandwidth of test receiver/spectrum analyzer is 120KHz and video bandwidth is 300kHz for Peak detection and Quasi-peak detection at frequency below 1GHz.
4. All emission below 1GHz at 802.11b/g/n mode are all the same,so the 802.11g/n mode chosen as representative in final test.
5. According to technical experiences,all spurious emission of 802.11g/n mode at channel 1,6,11 or 3,6,9(for HT40) are almost the same below 1GHz,so that the channel 1 or 3(for HT40)was chosen as representative in final test.
6. The data is worse case.



| | | | |
|-------------|---------------------|-------------|------------|
| Power | : AC 120V | Pol/Phase | : VERTICAL |
| Test Mode 3 | : 802.11n HT40, CH3 | Temperature | : 23 °C |
| Memo | : | Humidity | : 65 % |

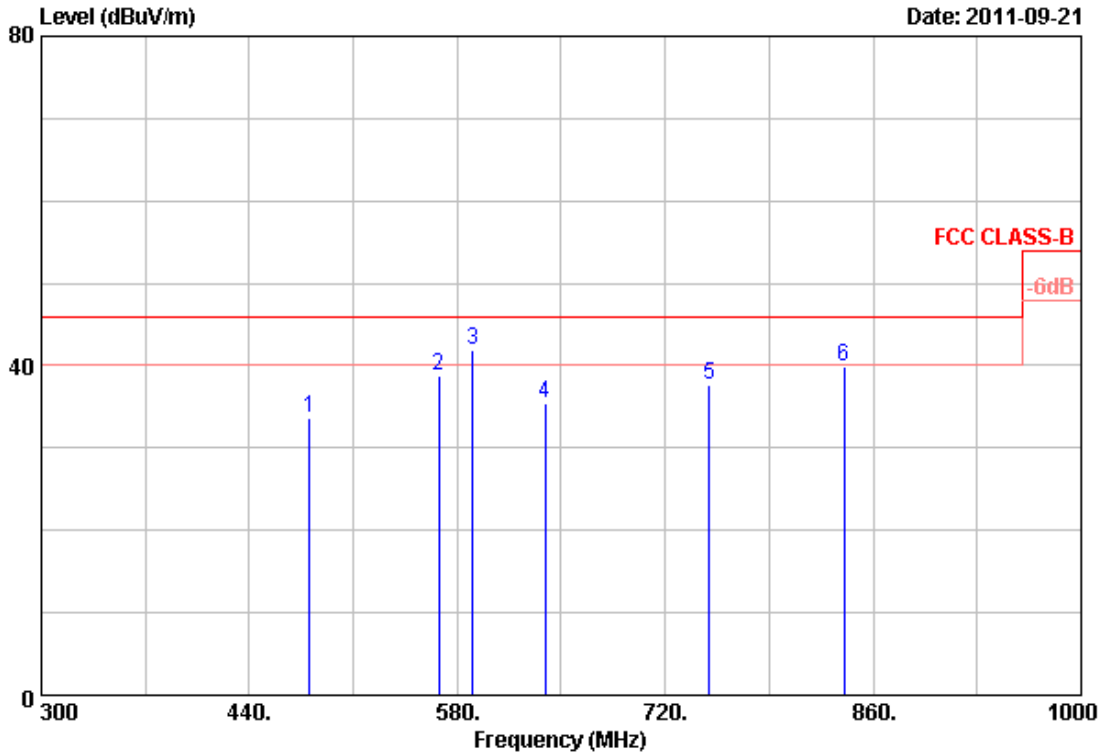

| Item | Freq | Read Value | Factor | Result | Limit | Margin | Remark | Ant Pos | Tab Pos |
|------|--------|------------|--------|--------|--------|--------|--------|---------|---------|
| | MHz | dBuV | dB/m | dBuV/m | dBuV/m | dB | | cm | Deg |
| 1 | 480.60 | 34.19 | -0.65 | 33.54 | 46.00 | -12.46 | Peak | 100 | 0 |
| 2 | 567.40 | 29.86 | 8.98 | 38.84 | 46.00 | -7.16 | Peak | 100 | 0 |
| 3 | 590.50 | 35.63 | 6.33 | 41.96 | 46.00 | -4.04 | QP | 100 | 0 |
| 4 | 639.50 | 31.93 | 3.46 | 35.39 | 46.00 | -10.61 | Peak | 100 | 0 |
| 5 | 749.40 | 29.33 | 8.23 | 37.56 | 46.00 | -8.44 | Peak | 100 | 0 |
| 6 | 840.40 | 24.23 | 15.58 | 39.81 | 46.00 | -6.19 | Peak | 100 | 0 |

Notes:

1. Result = Read Value + Factor
2. Factor = Antenna Factor + Cable Loss - Amplifier
3. The resolution bandwidth of test receiver/spectrum analyzer is 120KHz and video bandwidth is 300kHz for Peak detection and Quasi-peak detection at frequency below 1GHz.
4. All emission below 1GHz at 802.11b/g/n mode are all the same,so the 802.11g/n mode chosen as representative in final test.
5. According to technical experiences,all spurious emission of 802.11g/n mode at channel 1,6,11 or 3,6,9(for HT40) are almost the same below 1GHz,so that the channel 1 or 3(for HT40)was chosen as representative in final test.
6. The data is worse case.



| | | | |
|-------------|---------------------|-------------|--------------|
| Power | : AC 120V | Pol/Phase | : HORIZONTAL |
| Test Mode 3 | : 802.11n HT40, CH3 | Temperature | : 23 °C |
| Memo | : | Humidity | : 65 % |

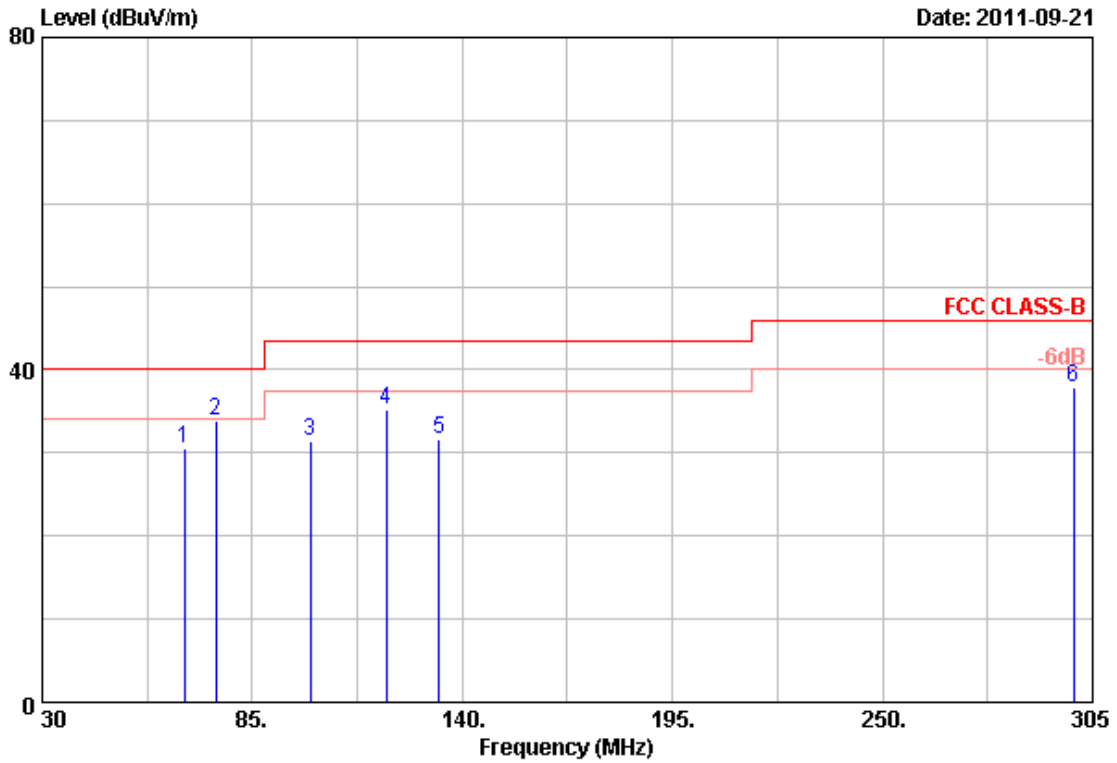

| Item | Freq | Read Value | Factor | Result | Limit | Margin | Remark | Ant Pos | Tab Pos |
|------|--------|------------|--------|--------|--------|--------|--------|---------|---------|
| | MHz | dBuV | dB/m | dBuV/m | dBuV/m | dB | | cm | Deg |
| 1 | 67.13 | 46.10 | -15.64 | 30.46 | 40.00 | -9.54 | Peak | 100 | 360 |
| 2 | 75.38 | 48.44 | -14.67 | 33.77 | 40.00 | -6.23 | Peak | 100 | 360 |
| 3 | 100.13 | 39.48 | -8.02 | 31.46 | 43.50 | -12.04 | Peak | 100 | 360 |
| 4 | 120.20 | 45.54 | -10.27 | 35.27 | 43.50 | -8.23 | Peak | 100 | 360 |
| 5 | 133.95 | 41.38 | -9.64 | 31.74 | 43.50 | -11.76 | Peak | 100 | 360 |
| 6 | 300.05 | 43.92 | -6.07 | 37.85 | 46.00 | -8.15 | Peak | 100 | 360 |

Notes:

1. Result = Read Value + Factor
2. Factor = Antenna Factor + Cable Loss - Amplifier
3. The resolution bandwidth of test receiver/spectrum analyzer is 120KHz and video bandwidth is 300kHz for Peak detection and Quasi-peak detection at frequency below 1GHz.
4. All emission below 1GHz at 802.11b/g/n mode are all the same,so the 802.11g/n mode chosen as representative in final test.
5. According to technical experiences,all spurious emission of 802.11g/n mode at channel 1,6,11 or 3,6,9(for HT40) are almost the same below 1GHz,so that the channel 1 or 3(for HT40)was chosen as representative in final test.
6. The data is worse case.



| | | | |
|-------------|---------------------|-------------|--------------|
| Power | : AC 120V | Pol/Phase | : HORIZONTAL |
| Test Mode 3 | : 802.11n HT40, CH3 | Temperature | : 23 °C |
| Memo | : | Humidity | : 65 % |

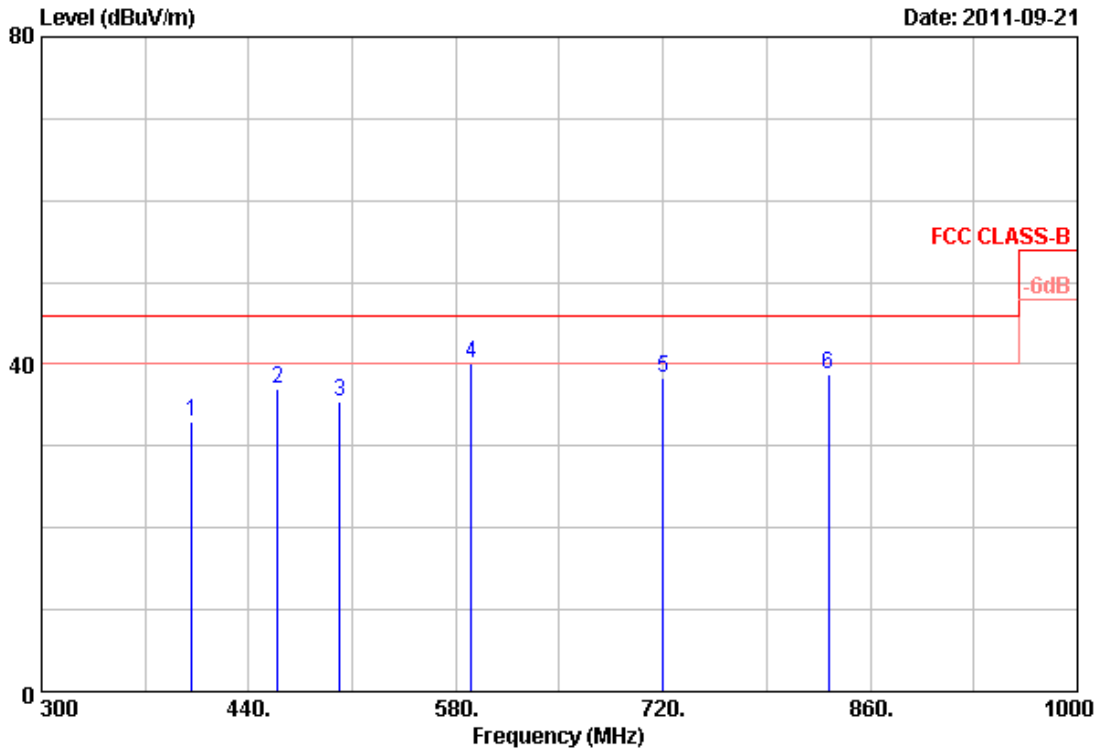

| Item | Freq MHz | Read Value dBUV | Factor dB/m | Result dBUV/m | Limit dBUV/m | Margin dB | Remark | Ant Pos cm | Tab Pos Deg |
|------|-------------|-----------------------|----------------|------------------|-----------------|--------------|--------|------------------|-------------------|
| 1 | 401.50 | 33.11 | -0.17 | 32.94 | 46.00 | -13.06 | Peak | 100 | 0 |
| 2 | 459.60 | 36.44 | 0.64 | 37.08 | 46.00 | -8.92 | Peak | 100 | 0 |
| 3 | 501.60 | 32.77 | 2.59 | 35.36 | 46.00 | -10.64 | Peak | 100 | 0 |
| 4 | 590.50 | 31.91 | 8.31 | 40.22 | 46.00 | -5.78 | QP | 100 | 0 |
| 5 | 720.00 | 32.97 | 5.32 | 38.29 | 46.00 | -7.71 | Peak | 100 | 0 |
| 6 | 832.00 | 25.31 | 13.57 | 38.88 | 46.00 | -7.12 | Peak | 100 | 0 |

Notes:

1. Result = Read Value + Factor
2. Factor = Antenna Factor + Cable Loss - Amplifier
3. The resolution bandwidth of test receiver/spectrum analyzer is 120KHz and video bandwidth is 300kHz for Peak detection and Quasi-peak detection at frequency below 1GHz.
4. All emission below 1GHz at 802.11b/g/n mode are all the same,so the 802.11g/n mode chosen as representative in final test.
5. According to technical experiences,all spurious emission of 802.11g/n mode at channel 1,6,11 or 3,6,9(for HT40) are almost the same below 1GHz,so that the channel 1 or 3(for HT40)was chosen as representative in final test.
6. The data is worse case.



| | | | |
|-------------|---------------------|-------------|------------|
| Power | : AC 120V | Pol/Phase | : VERTICAL |
| Test Mode 3 | : 802.11n HT40, CH3 | Temperature | : 23 °C |
| Memo | : | Humidity | : 65 % |

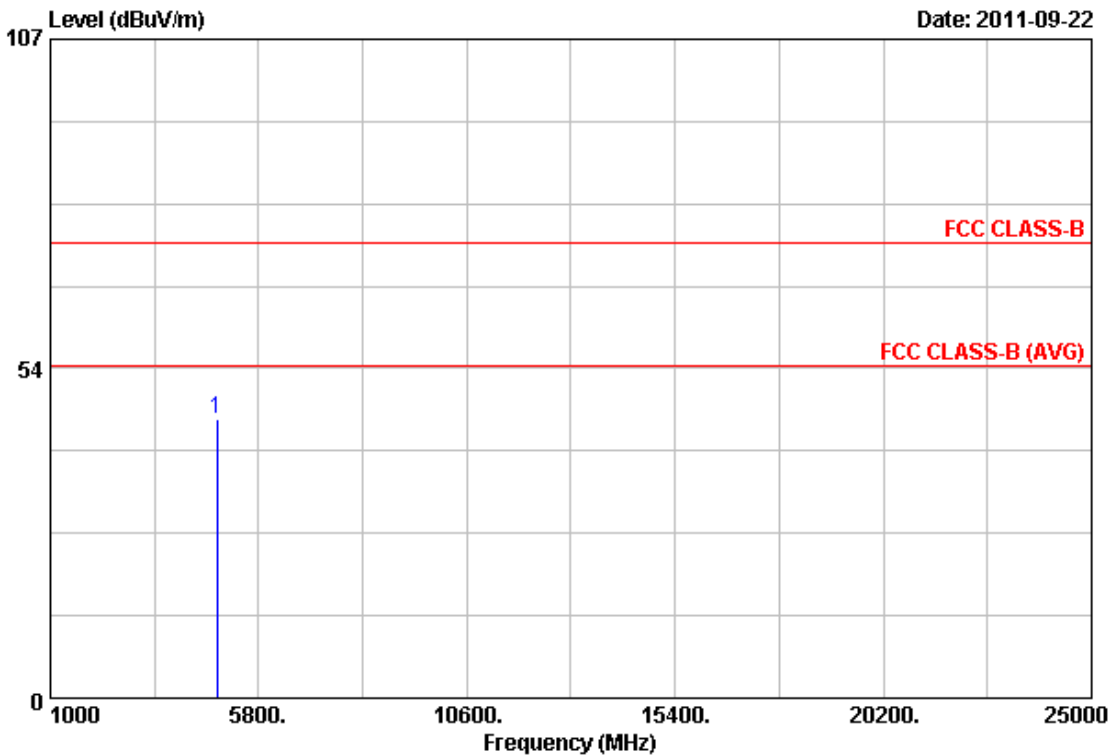

| Item | Freq | Read Value | Factor | Result | Limit | Margin | Remark | Ant Pos | Tab Pos |
|------|---------|------------|--------|--------|--------|--------|--------|---------|---------|
| | MHz | dBuV | dB/m | dBuV/m | dBuV/m | dB | | cm | Deg |
| 1 | 4844.00 | 39.57 | 5.77 | 45.34 | 74.00 | -28.66 | Peak | 100 | 187 |

Notes:

1. Result = Read Value + Factor
2. Factor = Antenna Factor + Cable Loss - Amplifier
3. The resolution bandwidth of test receiver/spectrum analyzer is 120KHz and video bandwidth is 300kHz for Peak detection and Quasi-peak detection at frequency below 1GHz.
4. The resolution bandwidth of test receiver/spectrum analyzer is 1MHz and video bandwidth is 3MHz for Peak detection at frequency above 1GHz.
5. The resolution bandwidth of test receiver/spectrum analyzer is 1MHz and video bandwidth is 10Hz for Average detection at frequency above 1GHz.
6. The other emissions is too low to be measured.
7. The data is worse case.



| | | | |
|-------------|---------------------|-------------|--------------|
| Power | : AC 120V | Pol/Phase | : HORIZONTAL |
| Test Mode 3 | : 802.11n HT40, CH3 | Temperature | : 23 °C |
| Memo | : | Humidity | : 65 % |

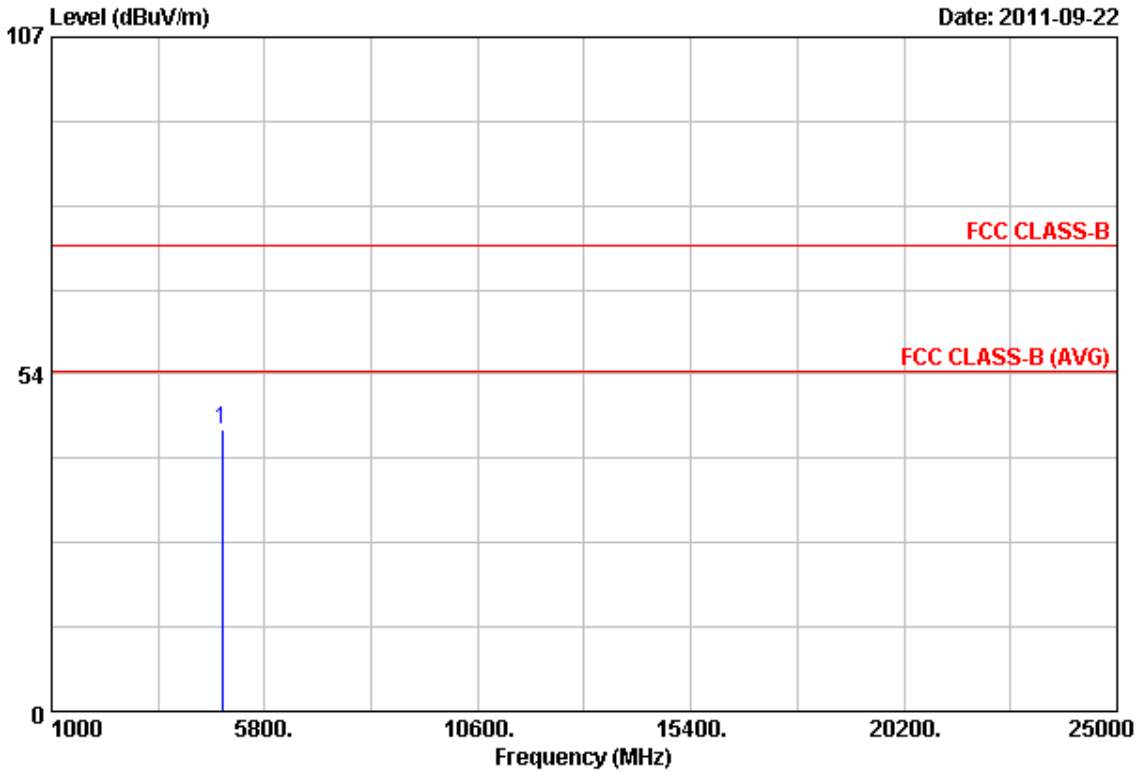

| Item | Freq | Read Value | Factor | Result | Limit | Margin | Remark | Ant Pos | Tab Pos |
|------|---------|------------|--------|--------|--------|--------|--------|---------|---------|
| | MHz | dBuV | dB/m | dBuV/m | dBuV/m | dB | | cm | Deg |
| 1 | 4844.00 | 40.63 | 4.03 | 44.66 | 74.00 | -29.34 | Peak | 100 | 187 |

Notes:

1. Result = Read Value + Factor
2. Factor = Antenna Factor + Cable Loss - Amplifier
3. The resolution bandwidth of test receiver/spectrum analyzer is 120KHz and video bandwidth is 300kHz for Peak detection and Quasi-peak detection at frequency below 1GHz.
4. The resolution bandwidth of test receiver/spectrum analyzer is 1MHz and video bandwidth is 3MHz for Peak detection at frequency above 1GHz.
5. The resolution bandwidth of test receiver/spectrum analyzer is 1MHz and video bandwidth is 10Hz for Average detection at frequency above 1GHz.
6. The other emissions is too low to be measured.
7. The data is worse case.



| | | | |
|-------------|---------------------|-------------|------------|
| Power | : AC 120V | Pol/Phase | : VERTICAL |
| Test Mode 3 | : 802.11n HT40, CH6 | Temperature | : 23 °C |
| Memo | : | Humidity | : 65 % |

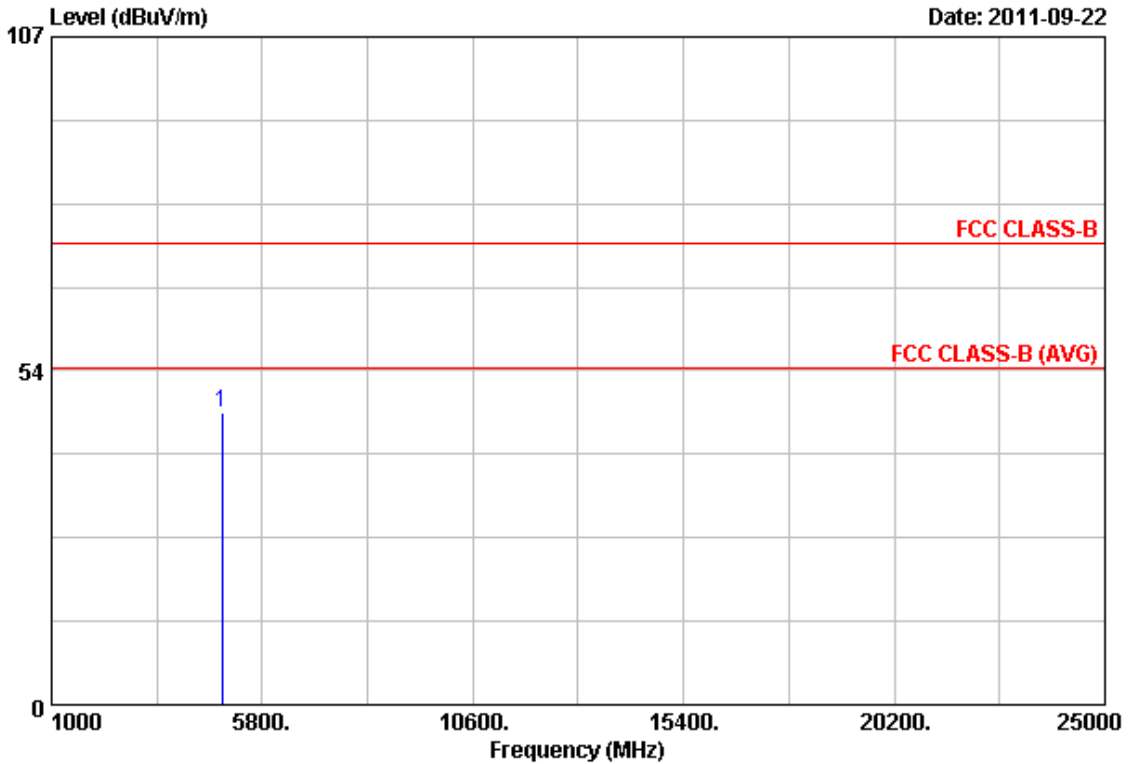

| Item | Freq | Read Value | Factor | Result | Limit | Margin | Remark | Ant Pos | Tab Pos |
|------|---------|------------|--------|--------|--------|--------|--------|---------|---------|
| | MHz | dBuV | dB/m | dBuV/m | dBuV/m | dB | | cm | Deg |
| 1 | 4874.00 | 40.47 | 6.36 | 46.83 | 74.00 | -27.17 | Peak | 100 | 187 |

Notes:

1. Result = Read Value + Factor
2. Factor = Antenna Factor + Cable Loss - Amplifier
3. The resolution bandwidth of test receiver/spectrum analyzer is 120KHz and video bandwidth is 300kHz for Peak detection and Quasi-peak detection at frequency below 1GHz.
4. The resolution bandwidth of test receiver/spectrum analyzer is 1MHz and video bandwidth is 3MHz for Peak detection at frequency above 1GHz.
5. The resolution bandwidth of test receiver/spectrum analyzer is 1MHz and video bandwidth is 10Hz for Average detection at frequency above 1GHz.
6. The other emissions is too low to be measured.
7. The data is worse case.



| | | | |
|-------------|---------------------|-------------|--------------|
| Power | : AC 120V | Pol/Phase | : HORIZONTAL |
| Test Mode 3 | : 802.11n HT40, CH6 | Temperature | : 23 °C |
| Memo | : | Humidity | : 65 % |

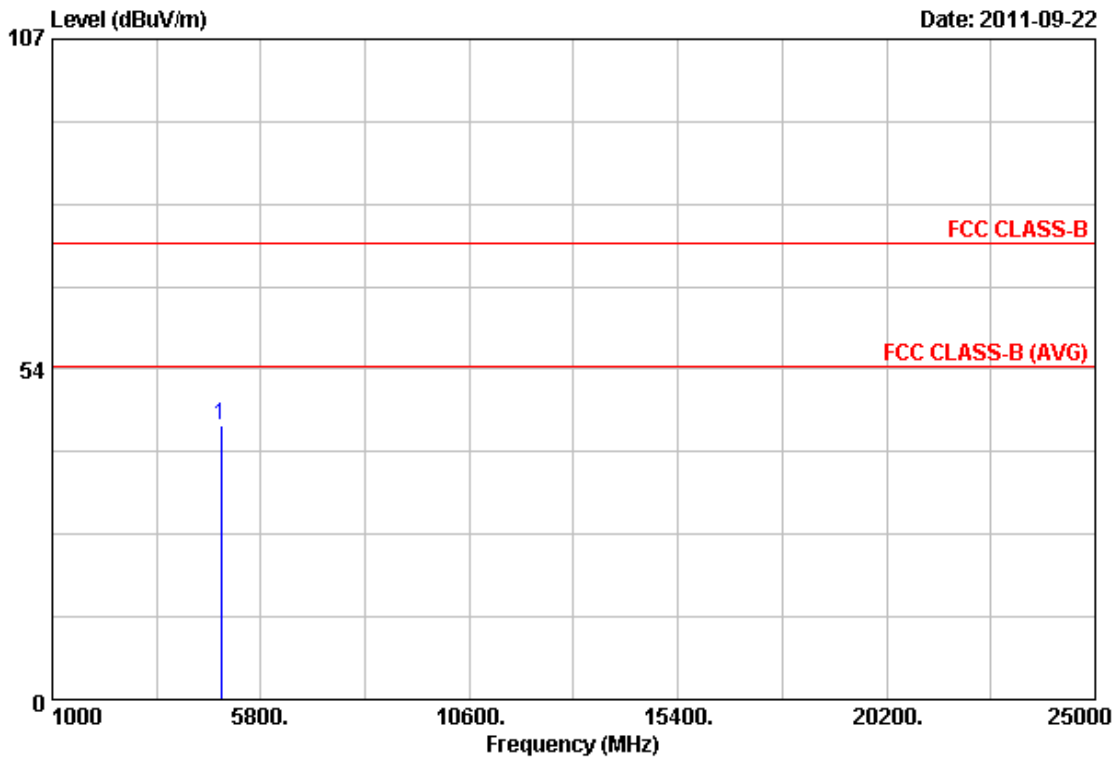

| Item | Freq | Read Value | Factor | Result | Limit | Margin | Remark | Ant Pos | Tab Pos |
|------|---------|------------|--------|--------|--------|--------|--------|---------|---------|
| | MHz | dBuV | dB/m | dBuV/m | dBuV/m | dB | | cm | Deg |
| 1 | 4874.00 | 40.01 | 4.50 | 44.51 | 74.00 | -29.49 | Peak | 100 | 187 |

Notes:

1. Result = Read Value + Factor
2. Factor = Antenna Factor + Cable Loss - Amplifier
3. The resolution bandwidth of test receiver/spectrum analyzer is 120KHz and video bandwidth is 300kHz for Peak detection and Quasi-peak detection at frequency below 1GHz.
4. The resolution bandwidth of test receiver/spectrum analyzer is 1MHz and video bandwidth is 3MHz for Peak detection at frequency above 1GHz.
5. The resolution bandwidth of test receiver/spectrum analyzer is 1MHz and video bandwidth is 10Hz for Average detection at frequency above 1GHz.
6. The other emissions is too low to be measured.
7. The data is worse case.



| | | | |
|-------------|---------------------|-------------|------------|
| Power | : AC 120V | Pol/Phase | : VERTICAL |
| Test Mode 3 | : 802.11n HT40, CH9 | Temperature | : 23 °C |
| Memo | : | Humidity | : 65 % |

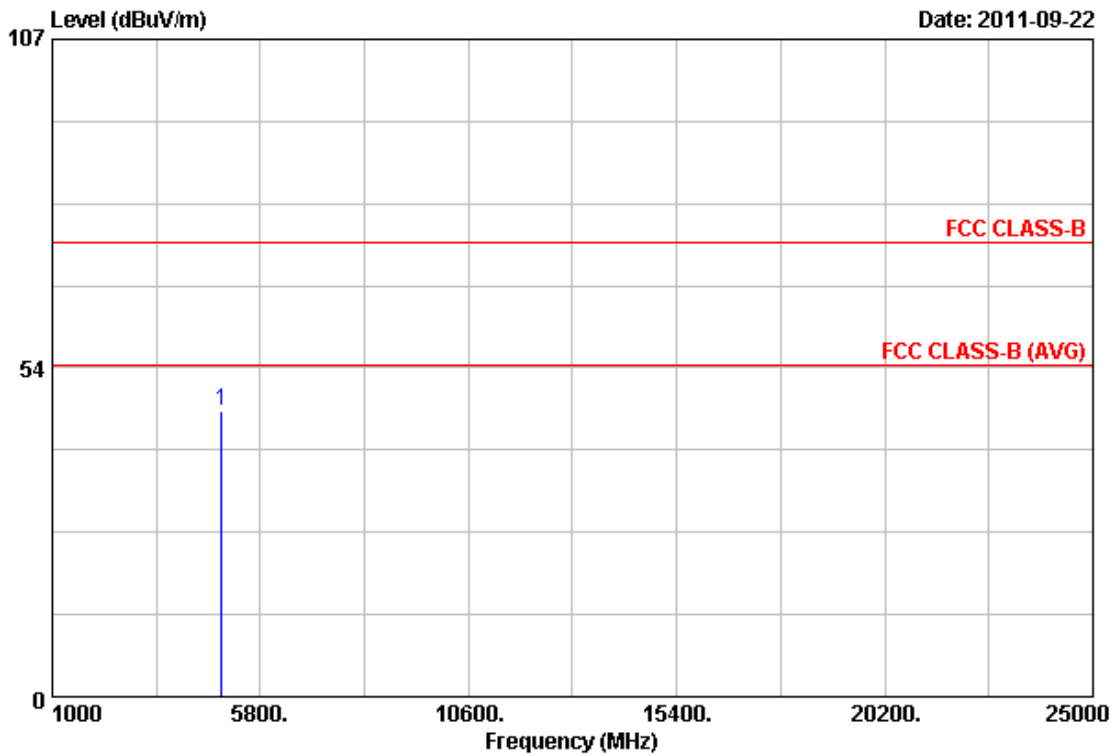

| Item | Freq | Read Value | Factor | Result | Limit | Margin | Remark | Ant Pos | Tab Pos |
|------|---------|------------|--------|--------|--------|--------|--------|---------|---------|
| | MHz | dBuV | dB/m | dBuV/m | dBuV/m | dB | | cm | Deg |
| 1 | 4904.00 | 39.73 | 6.89 | 46.62 | 74.00 | -27.38 | Peak | 100 | 187 |

Notes:

1. Result = Read Value + Factor
2. Factor = Antenna Factor + Cable Loss - Amplifier
3. The resolution bandwidth of test receiver/spectrum analyzer is 120KHz and video bandwidth is 300kHz for Peak detection and Quasi-peak detection at frequency below 1GHz.
4. The resolution bandwidth of test receiver/spectrum analyzer is 1MHz and video bandwidth is 3MHz for Peak detection at frequency above 1GHz.
5. The resolution bandwidth of test receiver/spectrum analyzer is 1MHz and video bandwidth is 10Hz for Average detection at frequency above 1GHz.
6. The other emissions is too low to be measured.
7. The data is worse case.



| | | | |
|-------------|---------------------|-------------|--------------|
| Power | : AC 120V | Pol/Phase | : HORIZONTAL |
| Test Mode 3 | : 802.11n HT40, CH9 | Temperature | : 23 °C |
| Memo | : | Humidity | : 65 % |

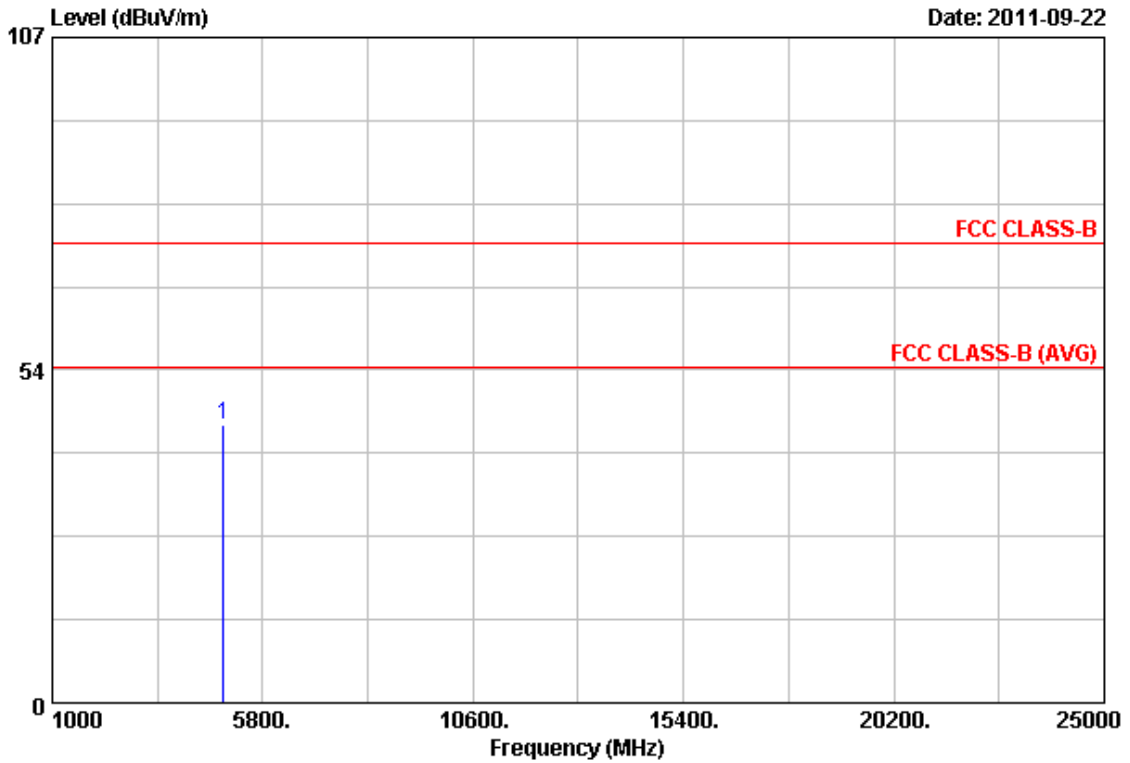

| Item | Freq | Read Value | Factor | Result | Limit | Margin | Remark | Ant Pos | Tab Pos |
|------|---------|------------|--------|--------|--------|--------|--------|---------|---------|
| | MHz | dBuV | dB/m | dBuV/m | dBuV/m | dB | | cm | Deg |
| 1 | 4904.00 | 39.73 | 4.92 | 44.65 | 74.00 | -29.35 | Peak | 100 | 187 |

Notes:

1. Result = Read Value + Factor
2. Factor = Antenna Factor + Cable Loss - Amplifier
3. The resolution bandwidth of test receiver/spectrum analyzer is 120KHz and video bandwidth is 300kHz for Peak detection and Quasi-peak detection at frequency below 1GHz.
4. The resolution bandwidth of test receiver/spectrum analyzer is 1MHz and video bandwidth is 3MHz for Peak detection at frequency above 1GHz.
5. The resolution bandwidth of test receiver/spectrum analyzer is 1MHz and video bandwidth is 10Hz for Average detection at frequency above 1GHz.
6. The other emissions is too low to be measured.
7. The data is worse case.

Test engineer: Ben



5.6 Test Photographs

Front View

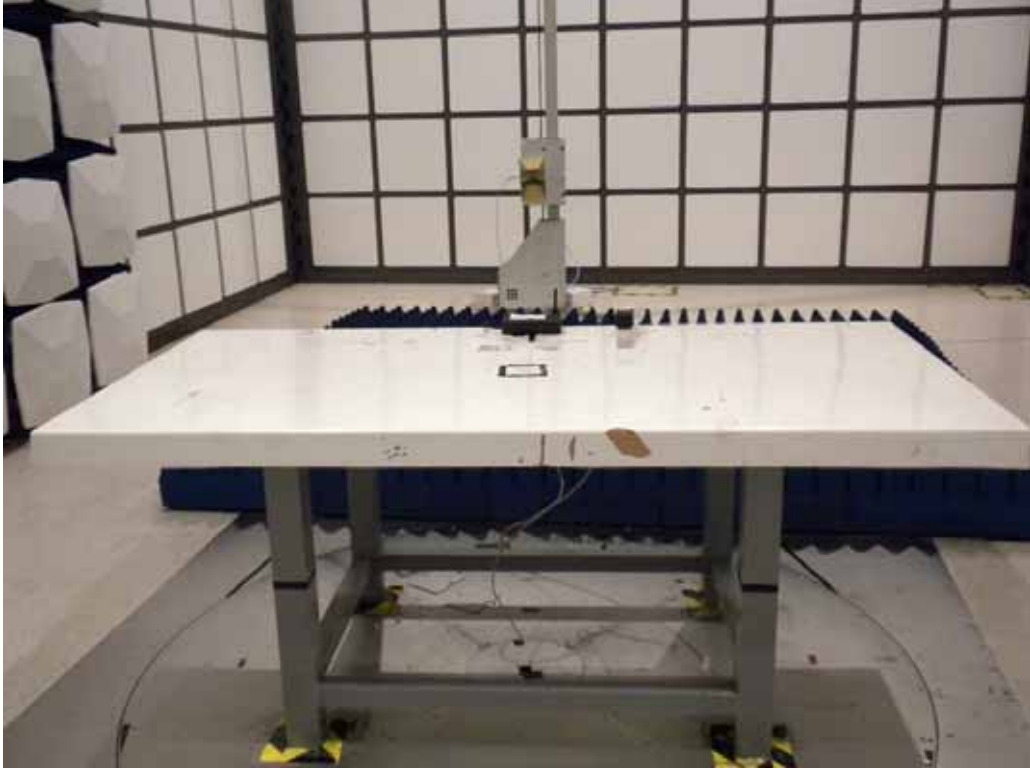

Rear View

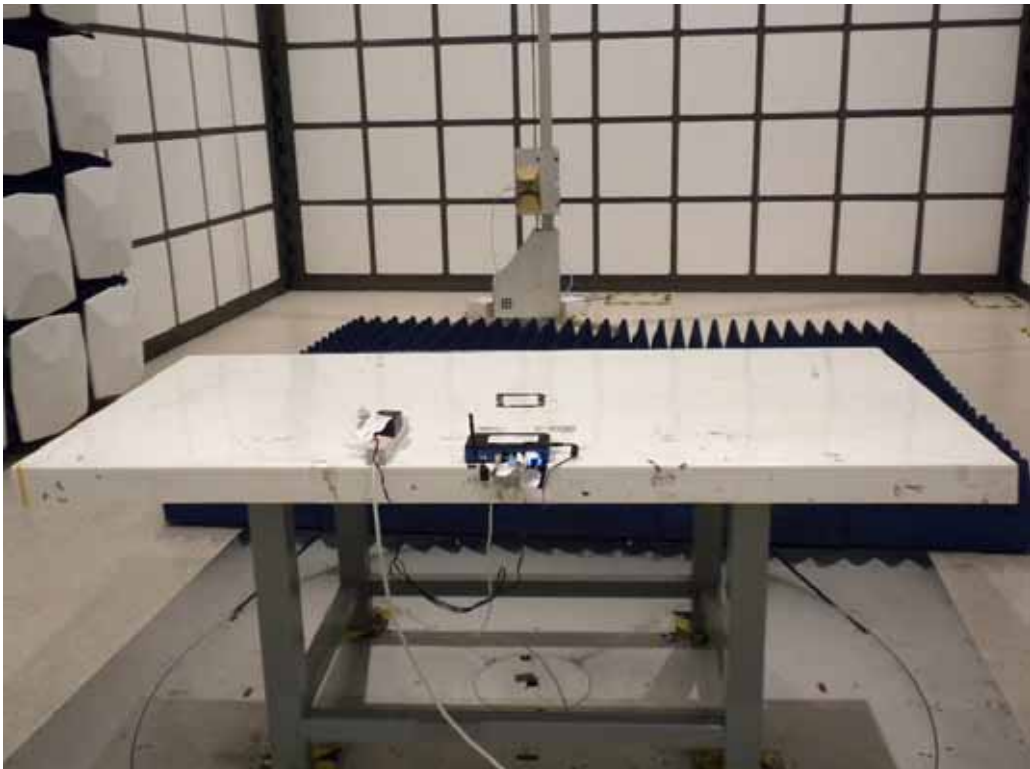



6. 6dB Bandwidth Measurement Data

6.1 Test Limit

The minimum of 6dB Bandwidth Measurement is 0.5 MHz.

6.2 Test Procedures

- The transmitter output was connected to the spectrum analyzer.
- Set RBW of spectrum analyzer to 100 KHz and VBW to 100 KHz.
- The 6 dB bandwidth is defined as the total spectrum the power of which is higher than peak power minus 6 dB.

6.3 Test Setup Layout

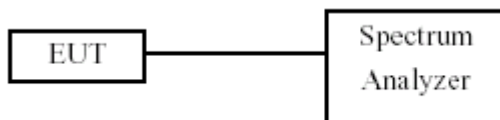

6.4 Measurement Equipment

| Instrument/Ancillary | Manufacturer | Model No. | Serial No. | Calibration Date | Valid Date |
|----------------------|--------------|-----------|------------|------------------|------------|
| Spectrum Analyzer | R&S | FSP40 | 100219 | 2010/11/05 | 2011/11/04 |

6.5 Test Result and Data

Test Date: Sep. 16, 2011

Temperature: 24°C

Atmospheric pressure: 1020 hPa

Humidity: 65%

| Modulation Standard | Channel | Frequency (MHz) | 6dB Bandwidth (MHz) |
|------------------------|---------|-----------------|---------------------|
| 802.11b (11Mbps) | 01 | 2412 | 11.5 |
| | 06 | 2437 | 11.3 |
| | 11 | 2462 | 11.3 |
| 802.11g (54Mbps) | 01 | 2412 | 16.6 |
| | 06 | 2437 | 16.6 |
| | 11 | 2462 | 16.6 |
| 802.11n HT20 (130Mbps) | 01 | 2412 | 17.8 |
| | 06 | 2437 | 17.8 |
| | 11 | 2462 | 17.8 |
| 802.11n HT40 (270Mbps) | 03 | 2422 | 36.4 |
| | 06 | 2437 | 36.4 |
| | 09 | 2452 | 36.4 |



Modulation Standard: 802.11b (11Mbps)
Channel: 01

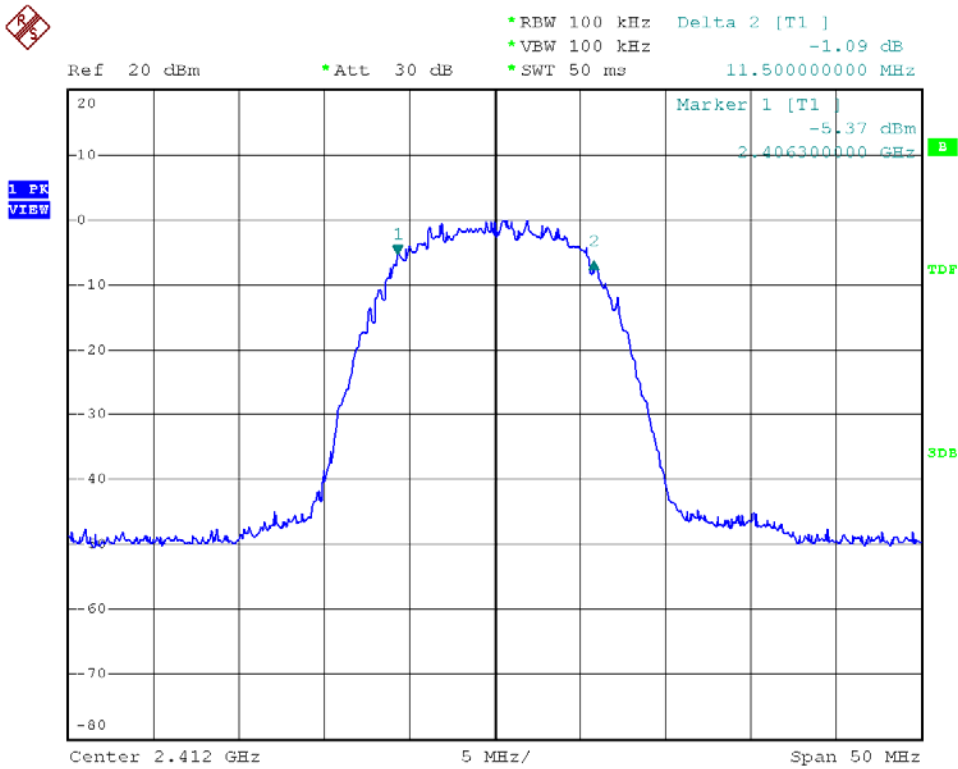

Modulation Standard: 802.11b (11Mbps)
Channel: 06

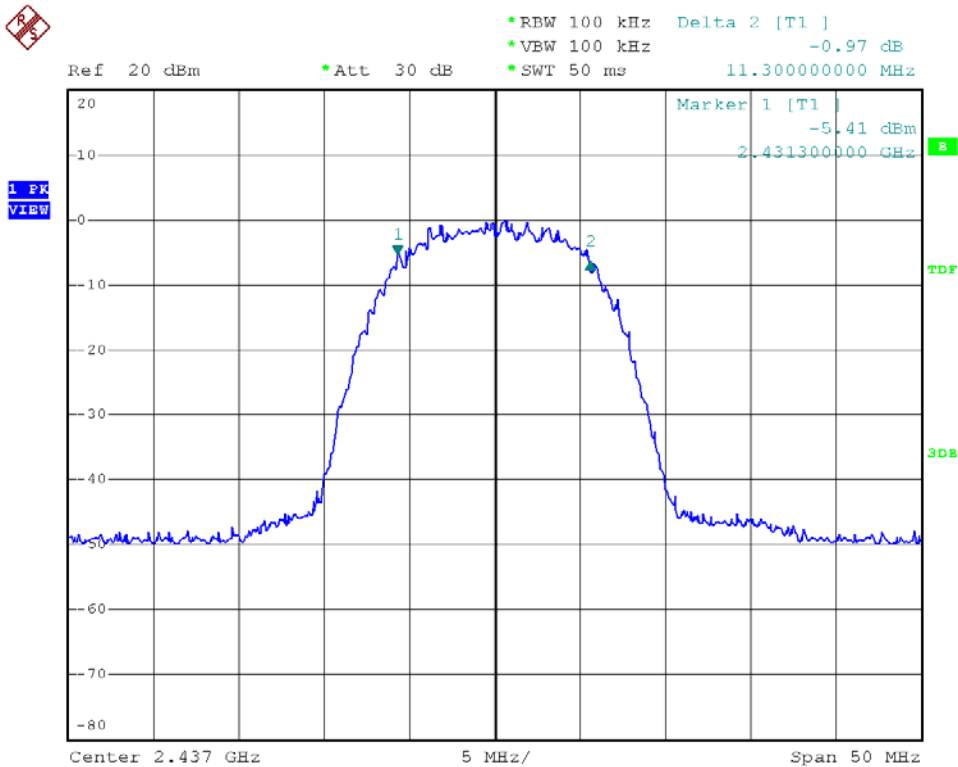



Modulation Standard: 802.11b (11Mbps)
Channel: 11

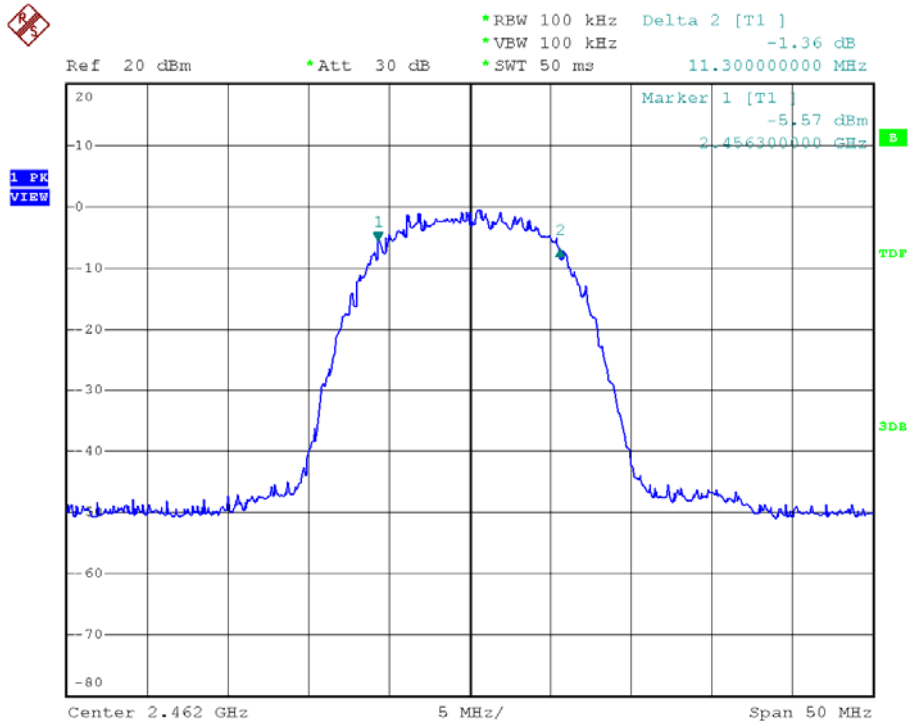

Modulation Standard: 802.11g (54Mbps)
Channel: 01

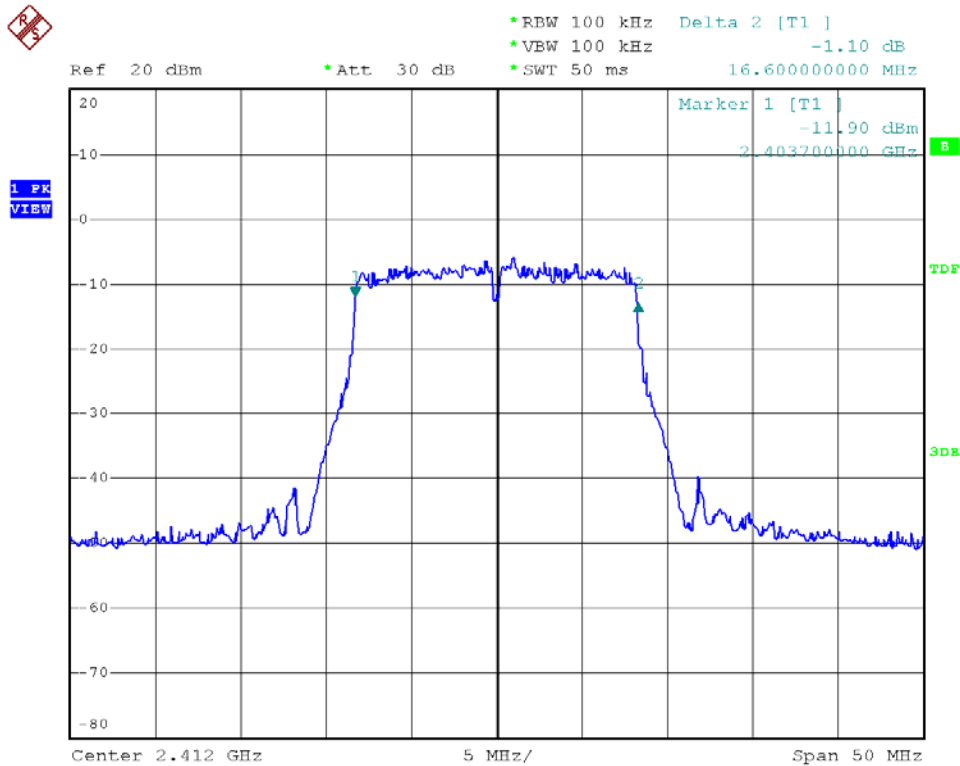



Modulation Standard: 802.11g (54Mbps)
Channel: 06

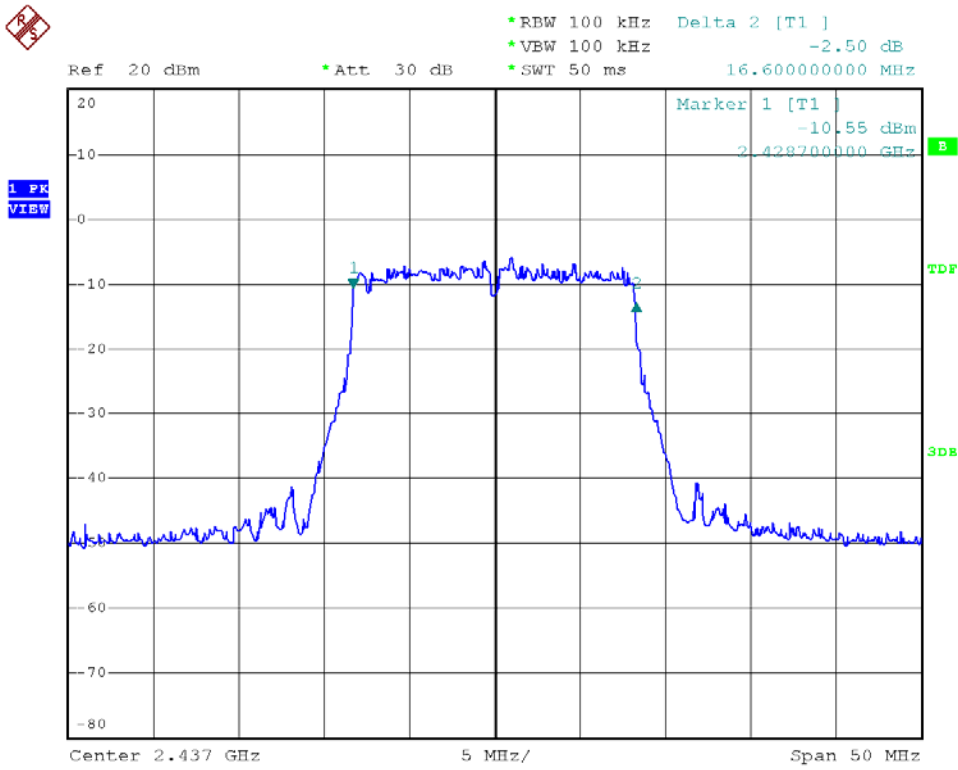

Modulation Standard: 802.11g (54Mbps)
Channel: 11

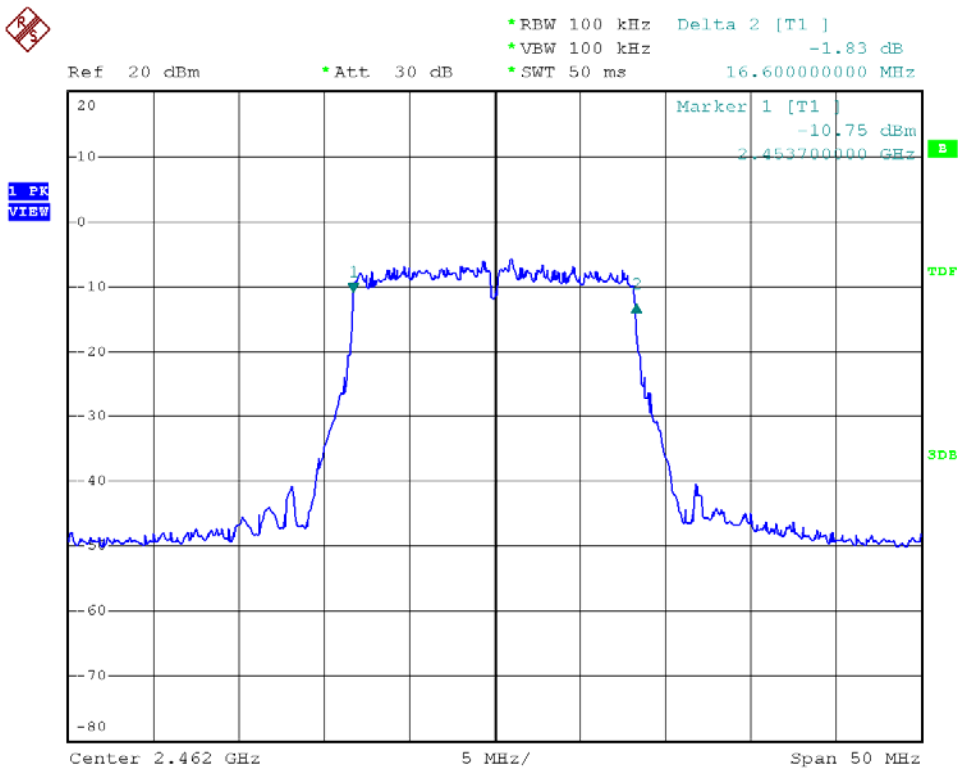



Modulation Standard: 802.11n HT20 (130Mbps)
Channel: 01

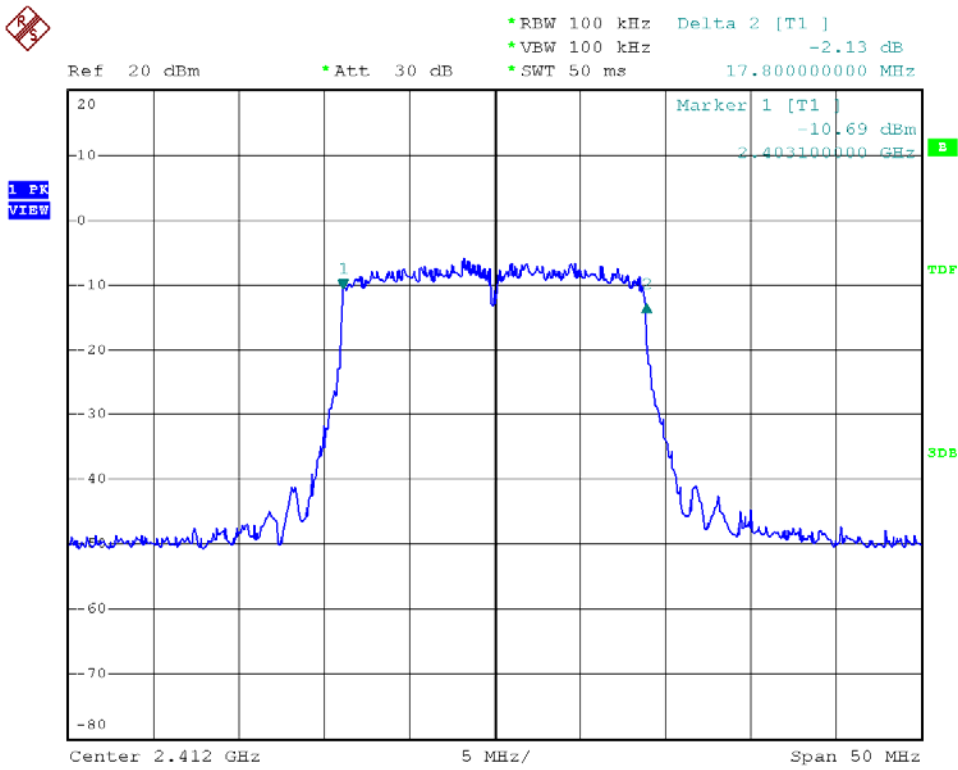

Modulation Standard: 802.11n HT20 (130Mbps)
Channel: 06

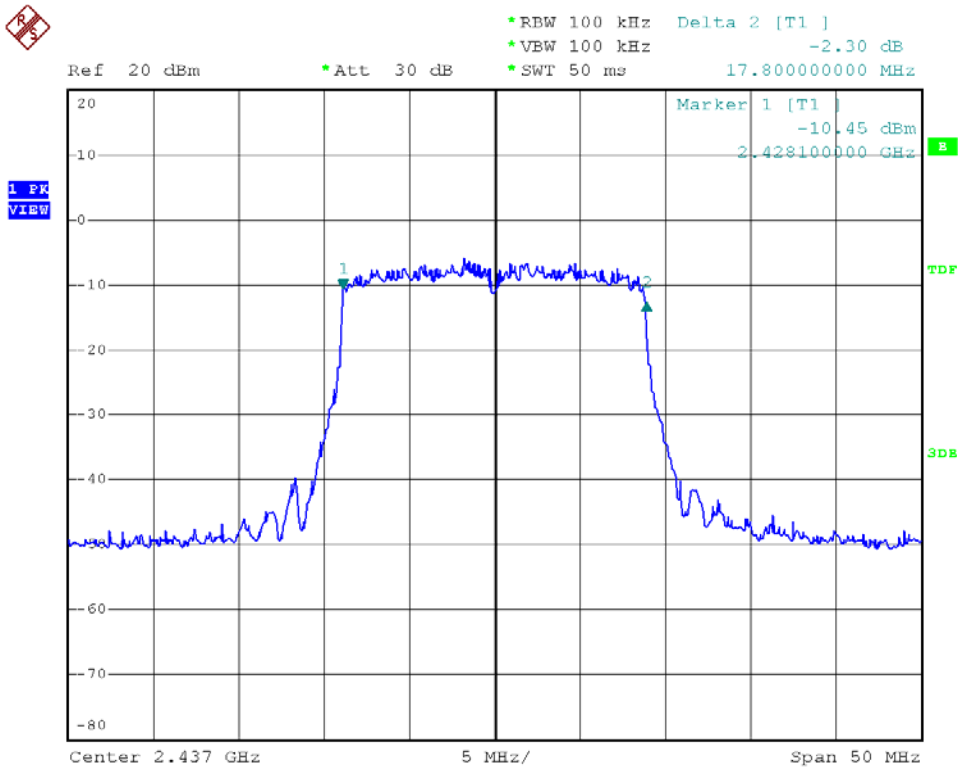



Modulation Standard: 802.11n HT20 (130Mbps)
Channel: 11

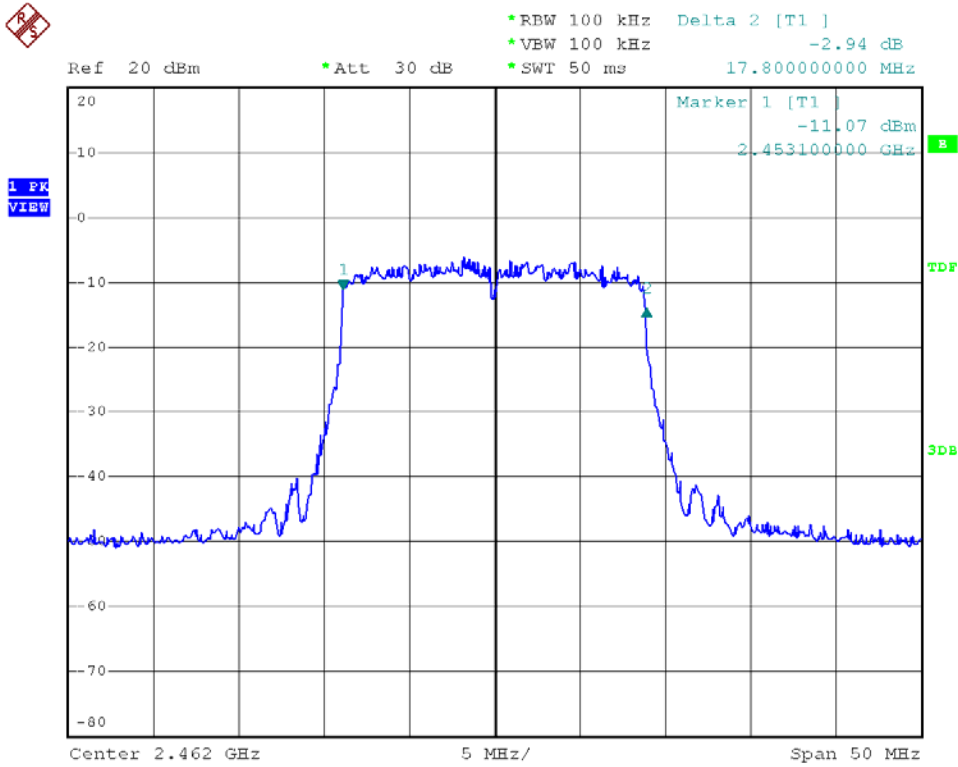

Modulation Standard: 802.11n HT40 (270Mbps)
Channel: 03

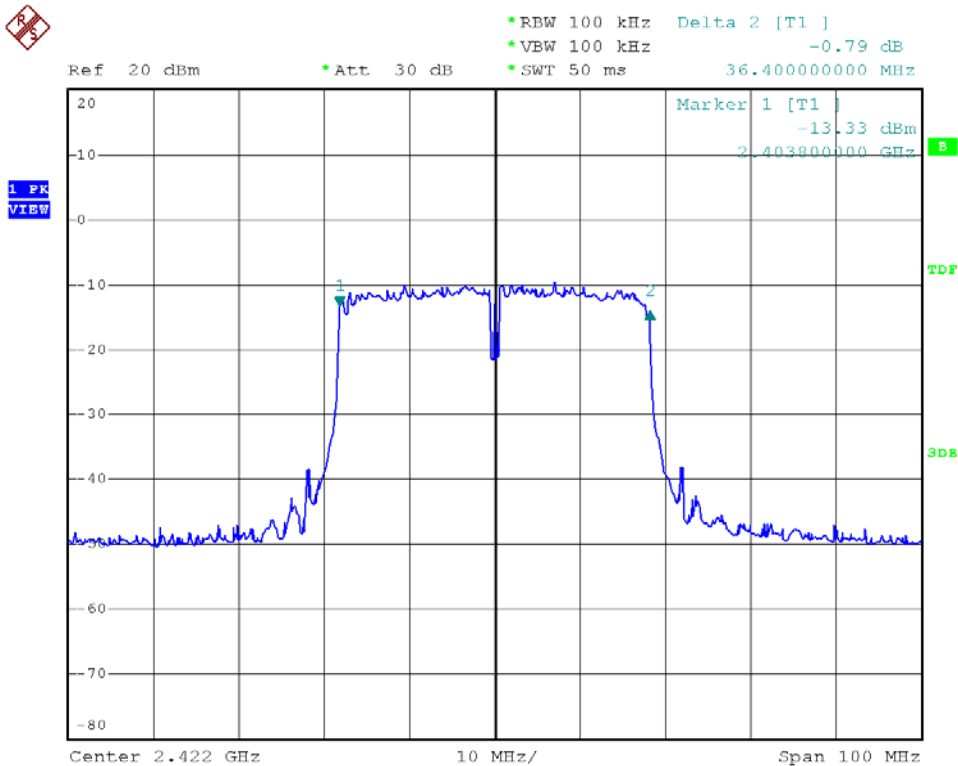



Modulation Standard: 802.11n HT40 (270Mbps)
Channel: 06

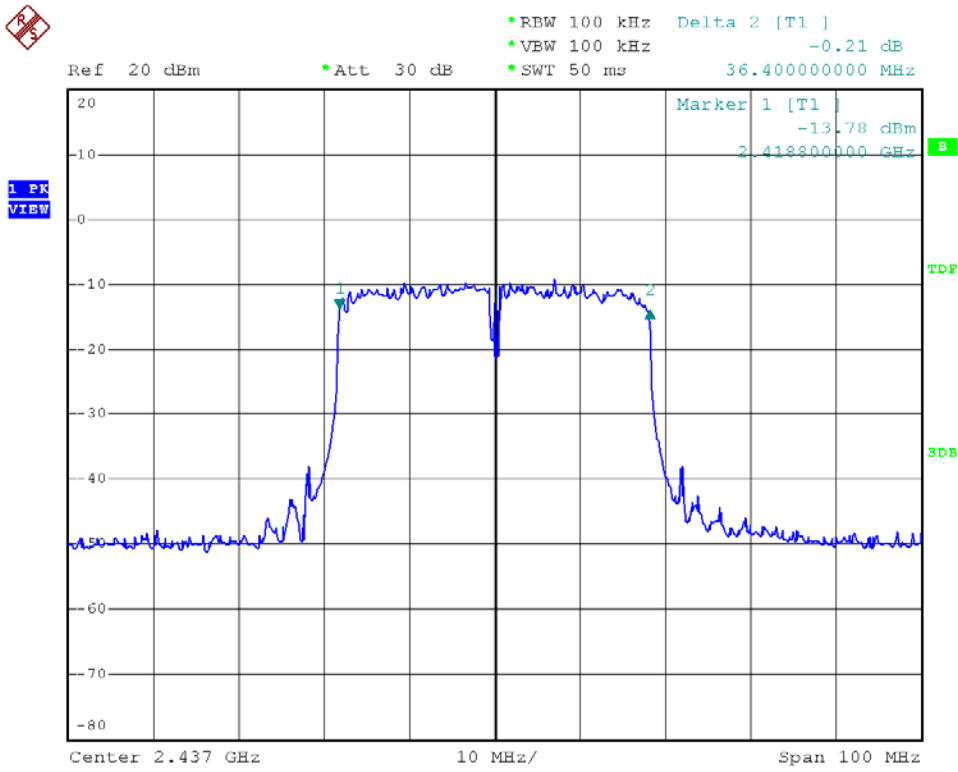

Modulation Standard: 802.11n HT40 (270Mbps)
Channel: 09

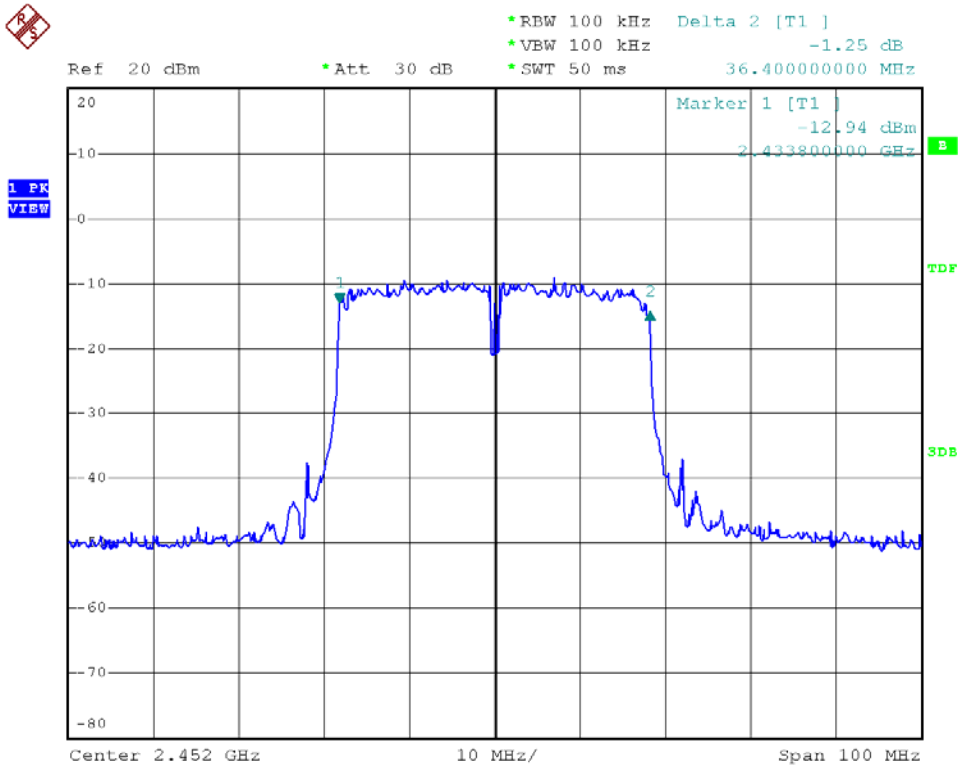



7. Maximum Peak Output Power

7.1 Test Limit

The Maximum Peak Output Power Measurement is 30dBm.

7.2 Test Procedures

The antenna port (RF output) of the EUT was connected to the input (RF input) of a power meter. Power was read directly from the meter and cable loss connection was added to the reading to obtain power at the EUT antenna terminal. The EUT Output Power was set to maximum to produce the worse case test result.

7.3 Test Setup Layout

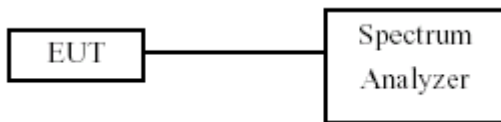

7.4 Measurement Equipment

| Instrument/Ancillary | Manufacturer | Model No. | Serial No. | Calibration Date | Valid Date |
|----------------------|--------------|-----------|------------|------------------|------------|
| Spectrum Analyzer | R&S | FSP40 | 100219 | 2010/11/05 | 2011/11/04 |



7.5 Test Result and Data

Test Date: Sep. 16, 2011

Temperature: 24°C

Atmospheric pressure: 1020 hPa

Humidity: 65%

| Modulation Standard | Channel | Frequency (MHz) | Peak Power Output (dBm) | Peak Power Output (mW) |
|---------------------|---------|-----------------|-------------------------|------------------------|
| 802.11b (11Mbps) | 01 | 2412 | 17.68 | 58.6 |
| | 06 | 2437 | 17.45 | 55.6 |
| | 11 | 2462 | 17.28 | 53.5 |
| 802.11g (54Mbps) | 01 | 2412 | 15.32 | 34.0 |
| | 06 | 2437 | 15.07 | 32.1 |
| | 11 | 2462 | 15.38 | 34.5 |

| Modulation Standard | Channel | Frequency (MHz) | Peak Power Output (dBm) | Peak Power Output (mW) |
|------------------------|---------|-----------------|-------------------------|------------------------|
| 802.11n HT20 (130Mbps) | 01 | 2412 | 15.24 | 33.4 |
| | 06 | 2437 | 15.39 | 34.6 |
| | 11 | 2462 | 15.29 | 33.8 |
| 802.11n HT40 (270Mbps) | 03 | 2422 | 15.13 | 32.6 |
| | 06 | 2437 | 15.26 | 33.6 |
| | 09 | 2452 | 15.35 | 34.3 |



Modulation Standard: 802.11b (11Mbps)
Channel: 01

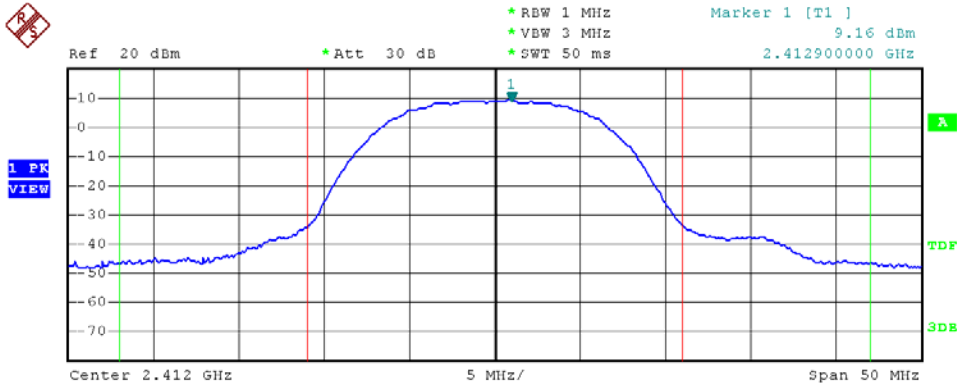

| | | | |
|--------------------------|----------|---------------------|-----------|
| Tx Channel | | WLAN 802.11B | |
| Bandwidth | 22 MHz | Power | 17.68 dBm |
| Adjacent Channel | | Lower | -49.39 dB |
| Bandwidth | 11 MHz | Upper | -47.53 dB |
| Spacing | 16.5 MHz | | |
| Alternate Channel | | Lower | ----- |
| Bandwidth | 11 MHz | Upper | ----- |
| Spacing | 27.5 MHz | | |

Modulation Standard: 802.11b (11Mbps)
Channel: 06

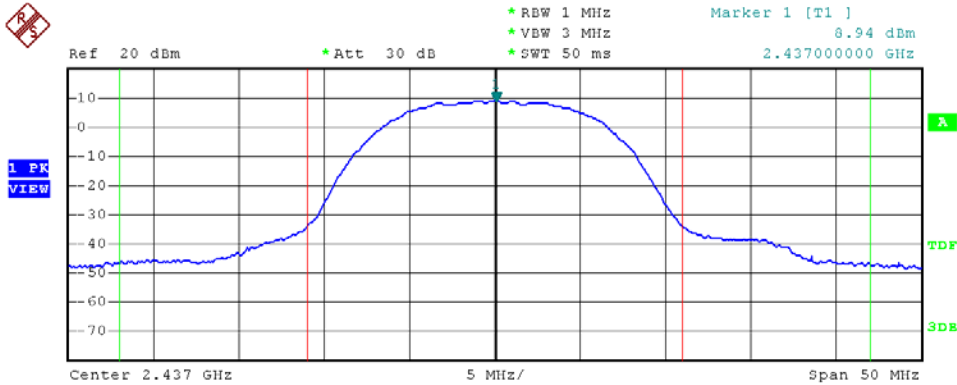

| | | | |
|--------------------------|----------|---------------------|-----------|
| Tx Channel | | WLAN 802.11B | |
| Bandwidth | 22 MHz | Power | 17.45 dBm |
| Adjacent Channel | | Lower | -49.45 dB |
| Bandwidth | 11 MHz | Upper | -47.73 dB |
| Spacing | 16.5 MHz | | |
| Alternate Channel | | Lower | ----- |
| Bandwidth | 11 MHz | Upper | ----- |
| Spacing | 27.5 MHz | | |



Modulation Standard: 802.11b (11Mbps)
Channel: 11

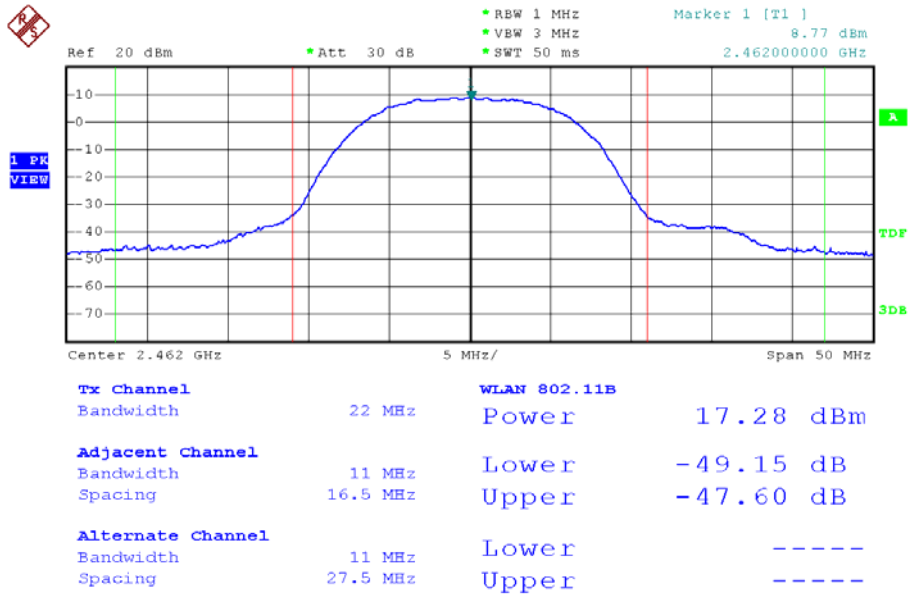

Modulation Standard: 802.11g (54Mbps)
Channel: 01

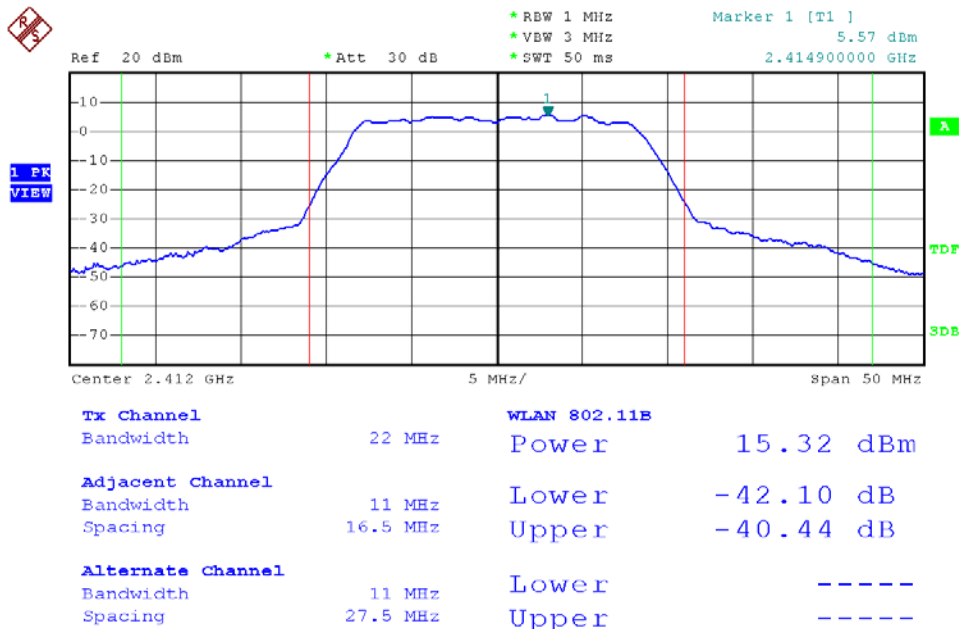



Modulation Standard: 802.11g (54Mbps)
Channel: 06

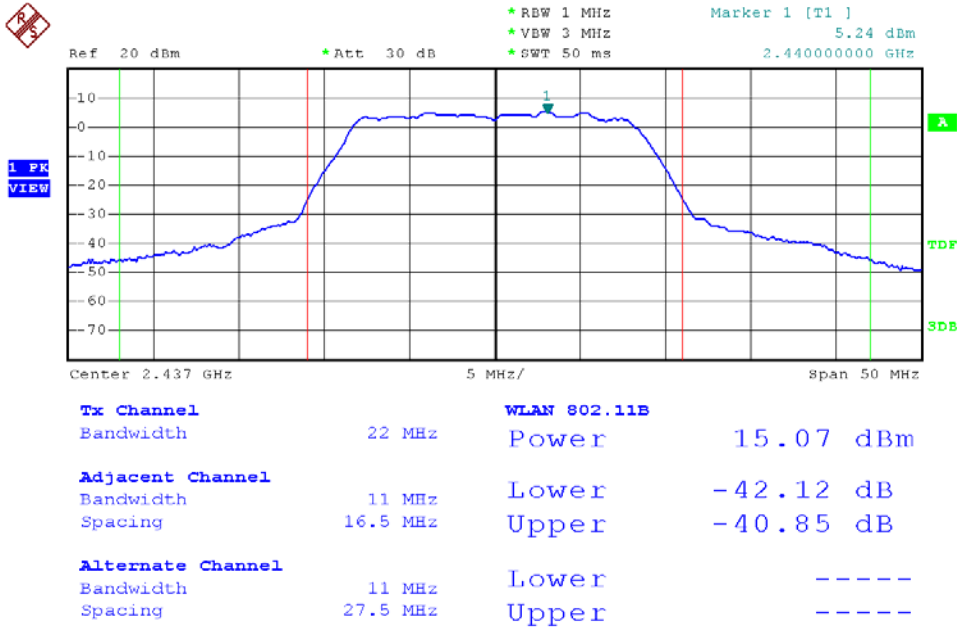

Modulation Standard: 802.11g (54Mbps)
Channel: 11

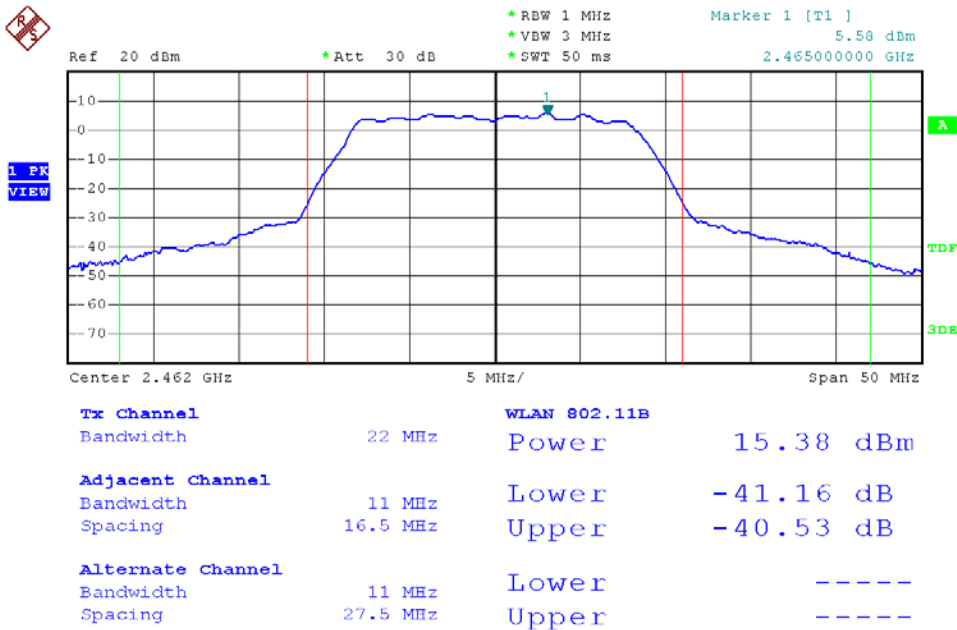



Modulation Standard: 802.11n HT20 (130Mbps)
Channel: 01

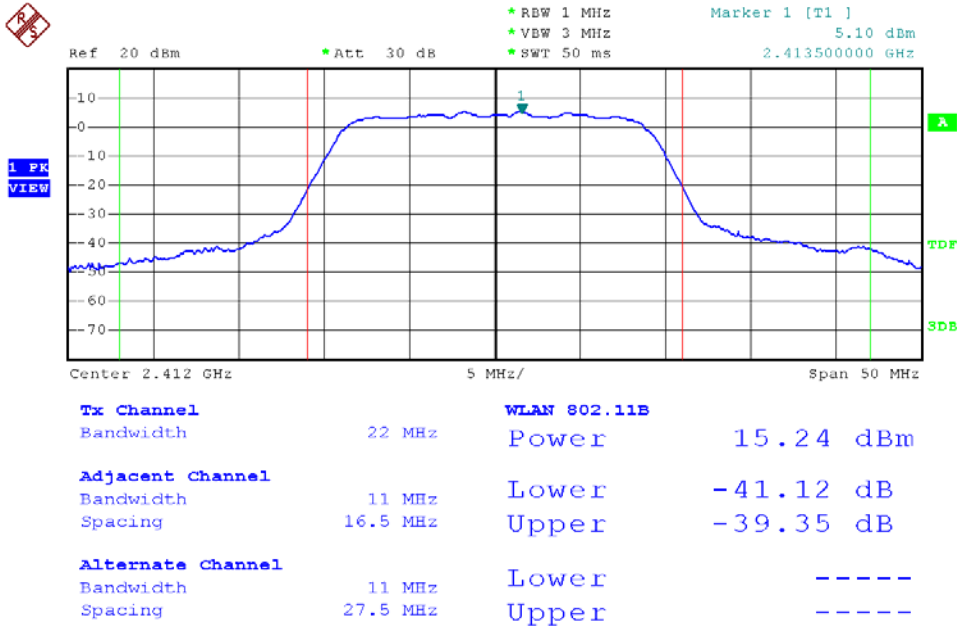

Modulation Standard: 802.11n HT20 (130Mbps)
Channel: 06

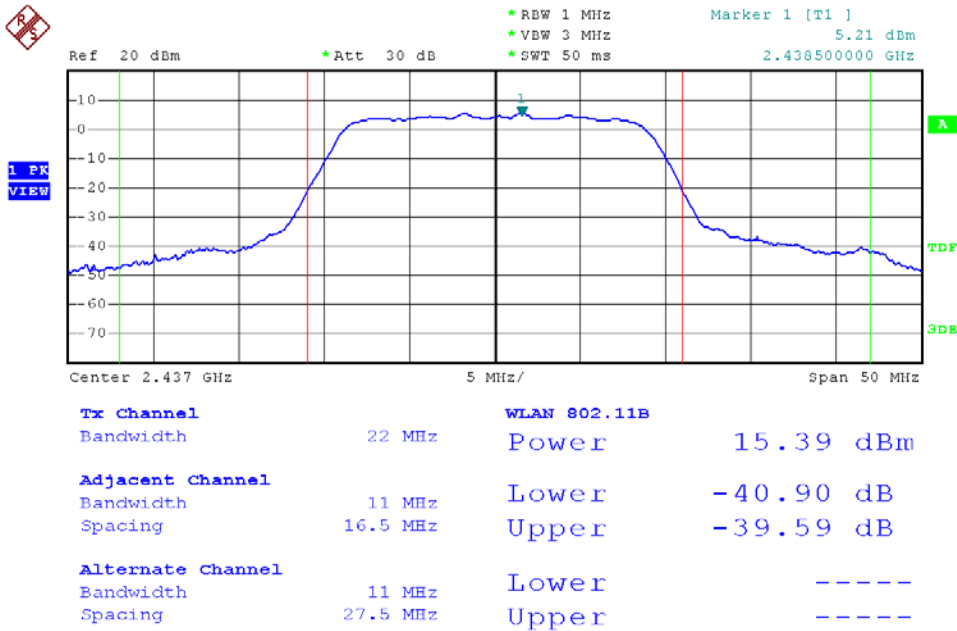



Modulation Standard: 802.11n HT20 (130Mbps)
Channel: 11

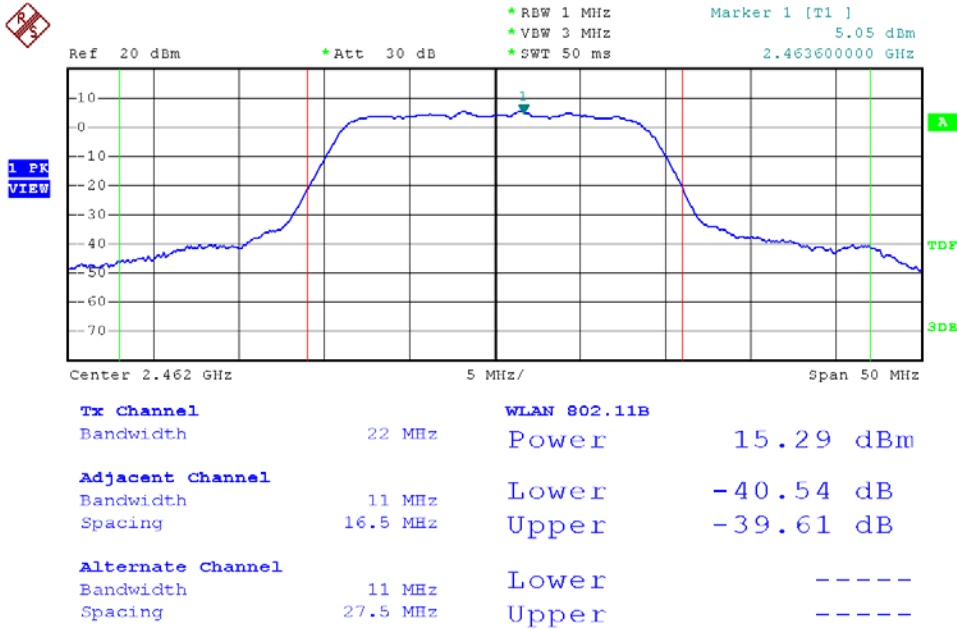

Modulation Standard: 802.11n HT40 (270Mbps)
Channel: 03

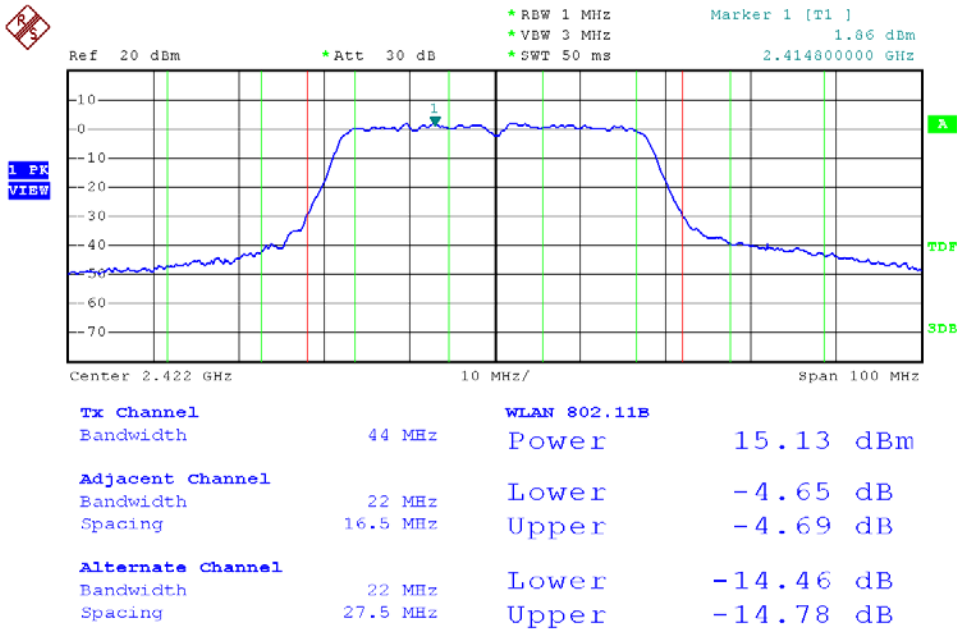



Modulation Standard: 802.11n HT40 (270Mbps)
Channel: 06

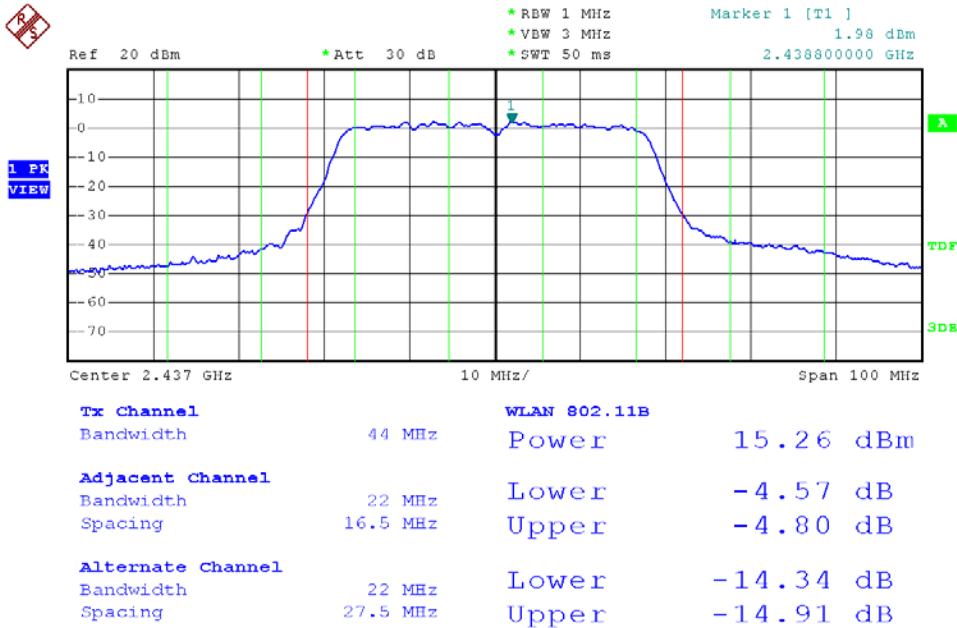

Modulation Standard: 802.11n HT40 (270Mbps)
Channel: 09

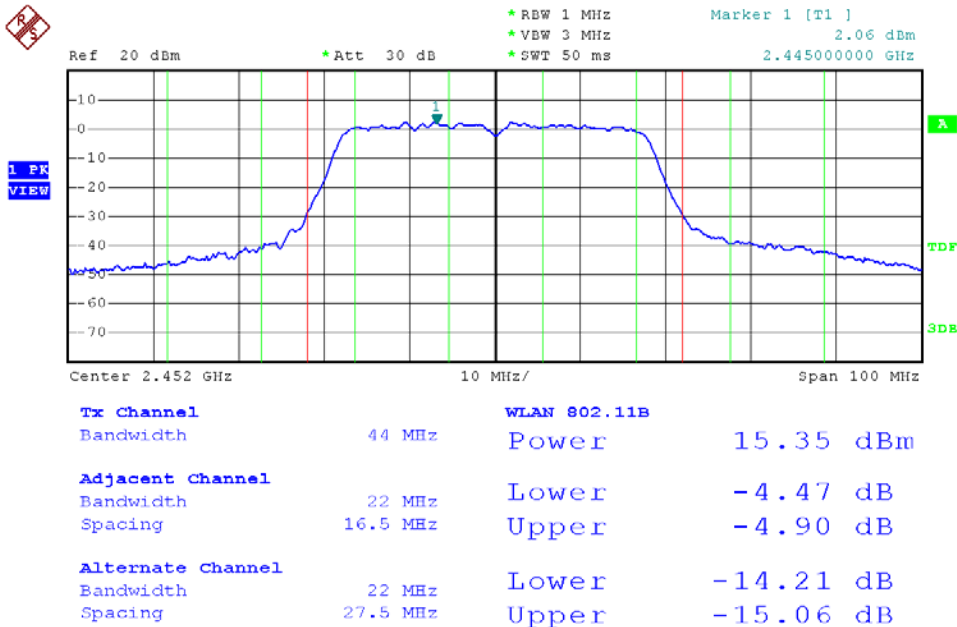



8. Power Spectral Density

8.1 Test Limit

The Maximum of Power Spectral Density Measurement is 8dBm.

8.2 Test Procedures

- a. The transmitter output was connected to spectrum analyzer.
- b. The spectrum analyzer’s resolution bandwidth were set at 3KHz RBW and 30KHz VBW as that of the fundamental frequency. Set the sweep time=span/3KHz.
- c. The power spectral density was measured and recorded.
- d. The Sweep time is allowed to be longer than span/3KHz for a full response of the mixer in the spectrum analyzer.

8.3 Test Setup Layout

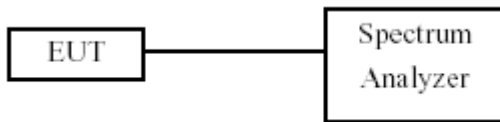

8.4 Measurement Equipment

| Instrument/Ancillary | Manufacturer | Model No. | Serial No. | Calibration Date | Valid Date |
|----------------------|--------------|-----------|------------|------------------|------------|
| Spectrum Analyzer | R&S | FSP40 | 100219 | 2010/11/05 | 2011/11/04 |

8.5 Test Result and Data

Test Date: Sep. 19, 2011

Temperature: 24°C

Atmospheric pressure: 1020 hPa

Humidity: 65%

| Modulation Standard | Channel | Frequency (MHz) | Maximum Power Density of 3 kHz Bandwidth (dBm) |
|------------------------|---------|-----------------|--|
| 802.11b (11Mbps) | 01 | 2412 | -10.76 |
| | 06 | 2437 | -11.00 |
| | 11 | 2462 | -11.41 |
| 802.11g (54Mbps) | 01 | 2412 | -15.67 |
| | 06 | 2437 | -15.83 |
| | 11 | 2462 | -15.87 |
| 802.11n HT20 (130Mbps) | 01 | 2412 | -15.41 |
| | 06 | 2437 | -15.12 |
| | 11 | 2462 | -15.44 |
| 802.11n HT40 (270Mbps) | 03 | 2422 | -15.88 |
| | 06 | 2437 | -15.75 |
| | 09 | 2452 | -15.93 |



Modulation Standard: 802.11b (11Mbps)
Channel: 01

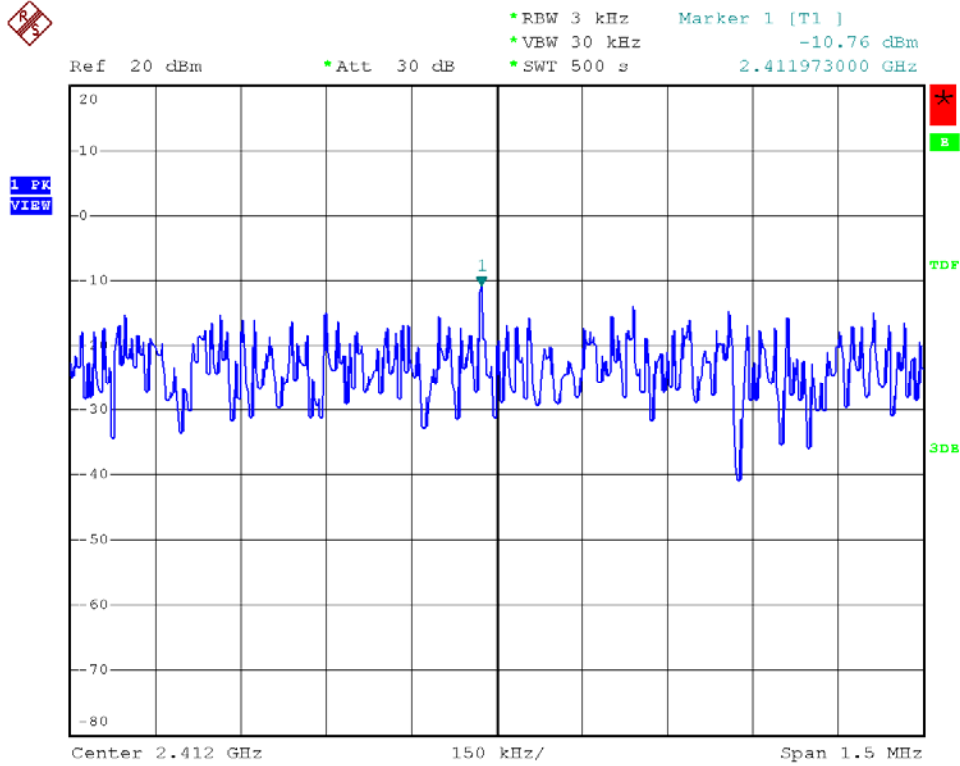

Modulation Standard: 802.11b (11Mbps)
Channel: 06

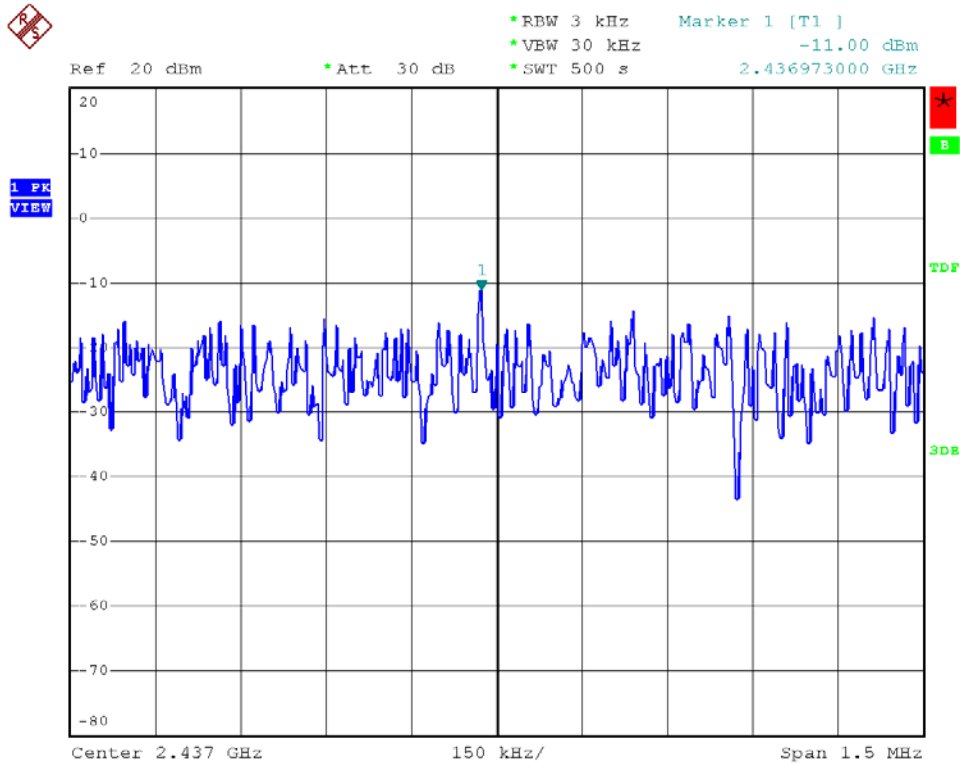



Modulation Standard: 802.11b (11Mbps)
Channel: 11

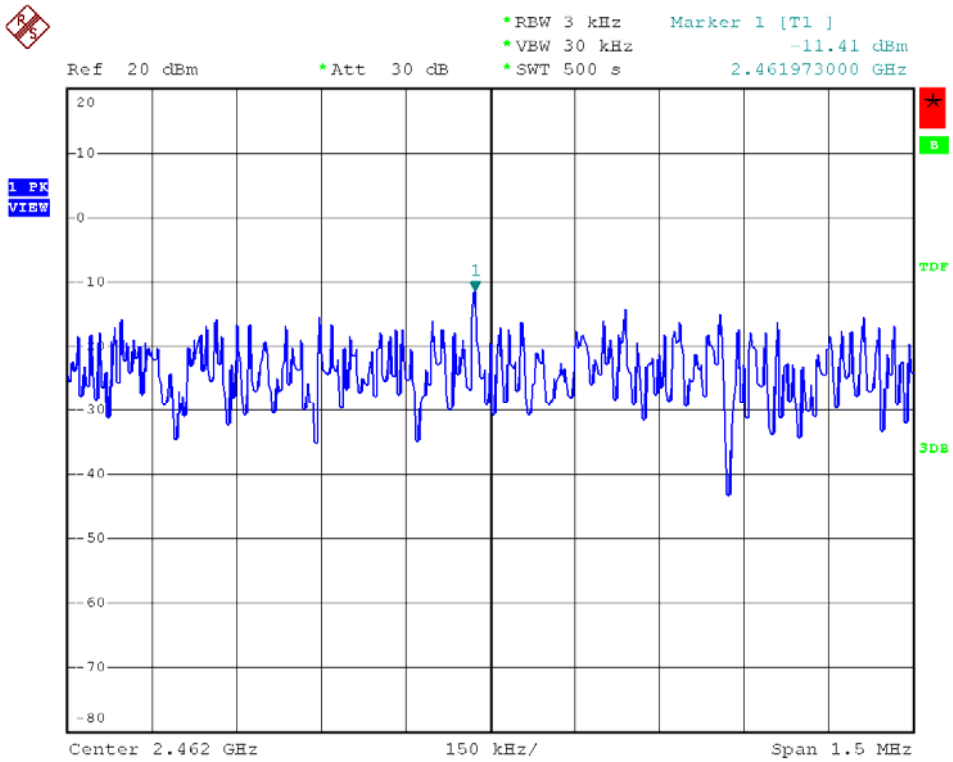

Modulation Standard: 802.11g (54Mbps)
Channel: 01

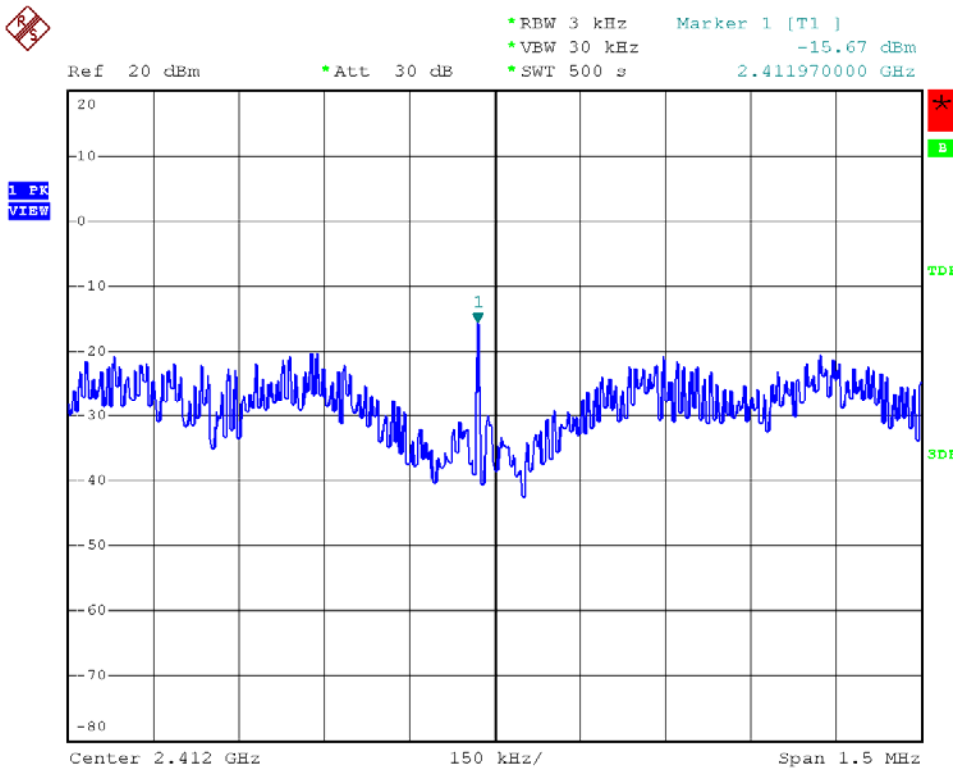



Modulation Standard: 802.11g (54Mbps)
Channel: 06

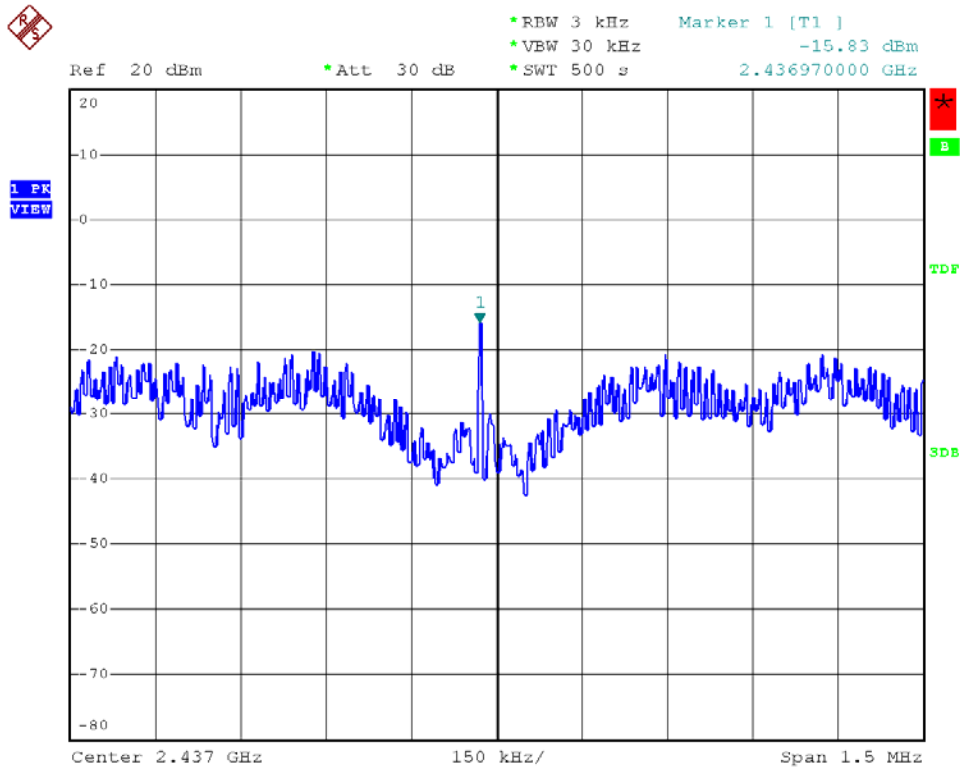

Modulation Standard: 802.11g (54Mbps)
Channel: 11

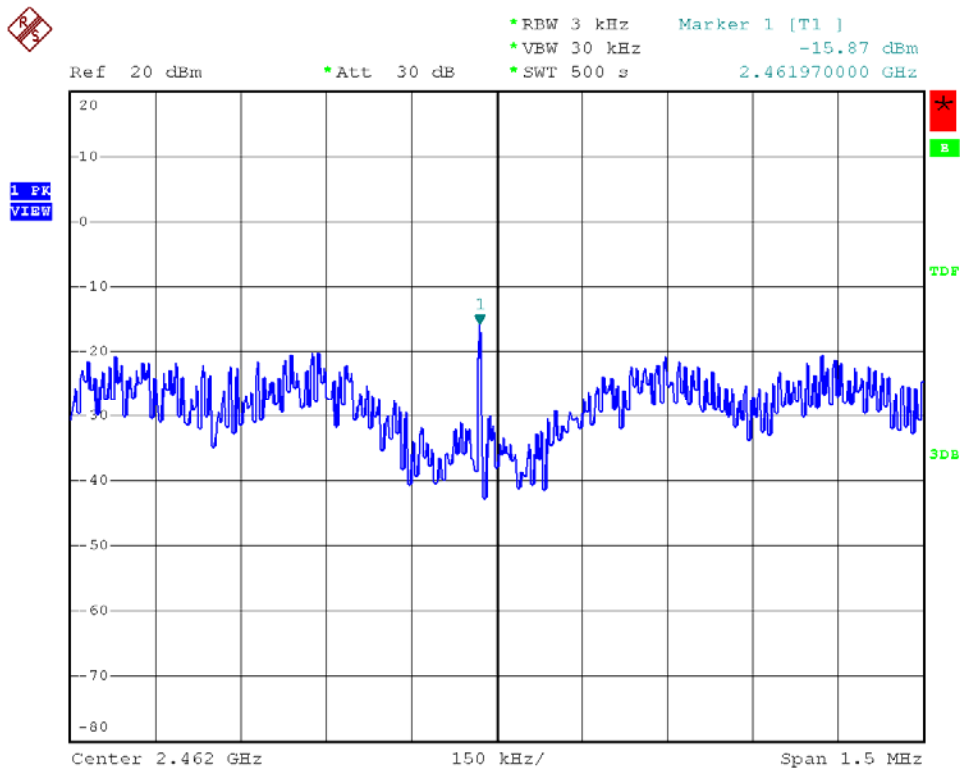



Modulation Standard: 802.11n HT20 (130Mbps)
Channel: 01

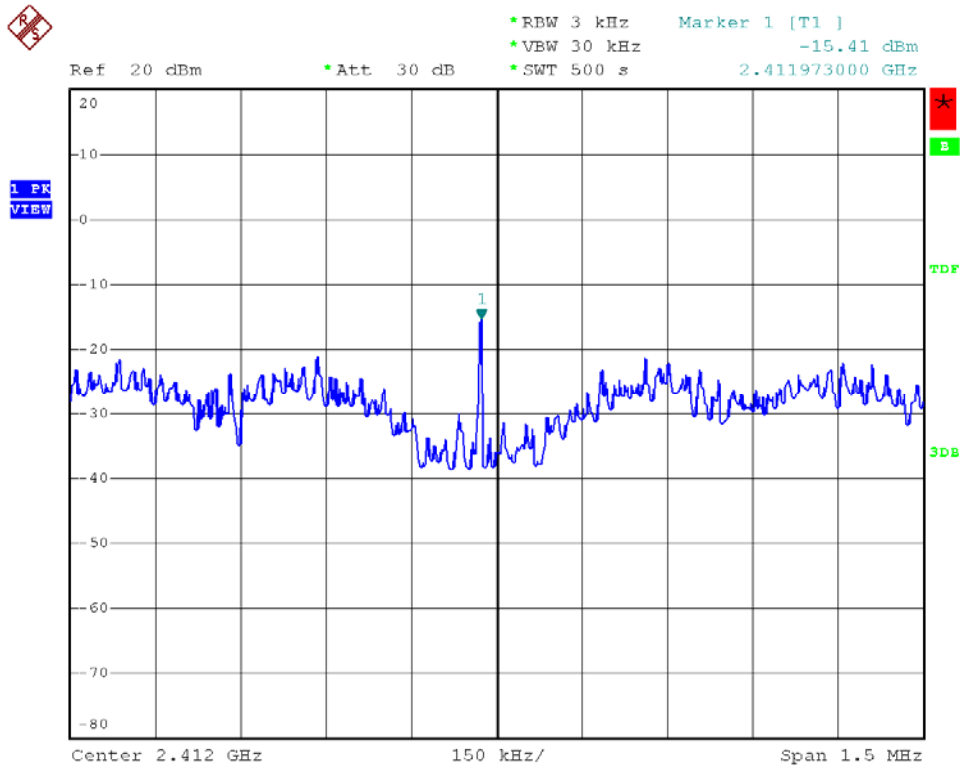

Modulation Standard: 802.11n HT20 (130Mbps)
Channel: 06

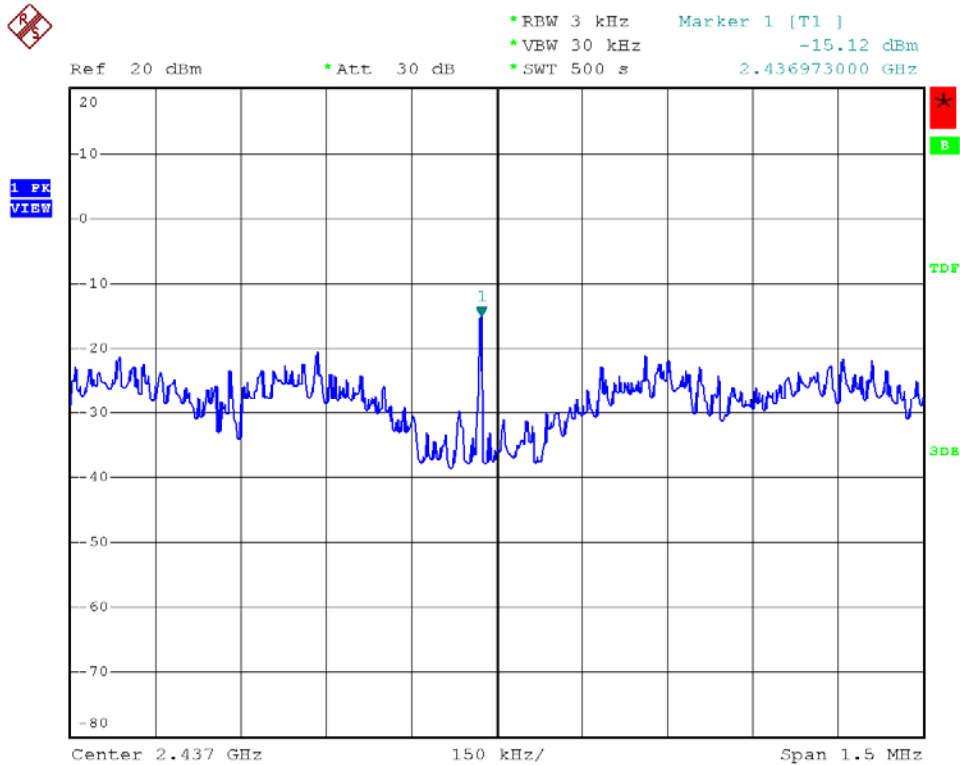



Modulation Standard: 802.11n HT20 (130Mbps)
Channel: 11

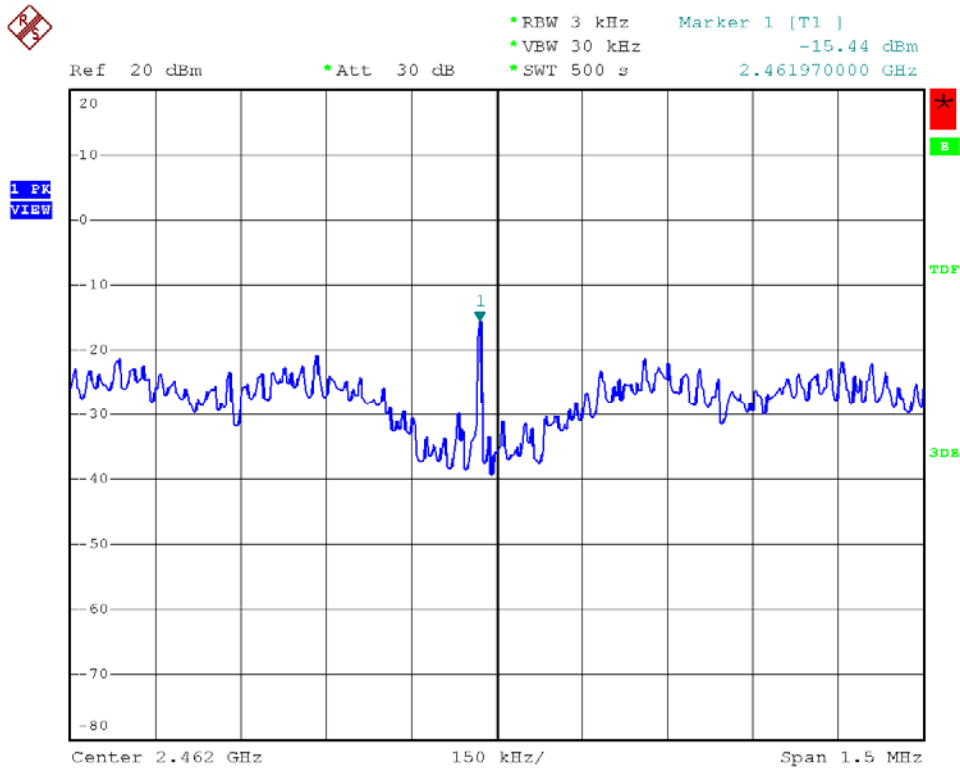

Modulation Standard: 802.11n HT40 (270Mbps)
Channel: 03

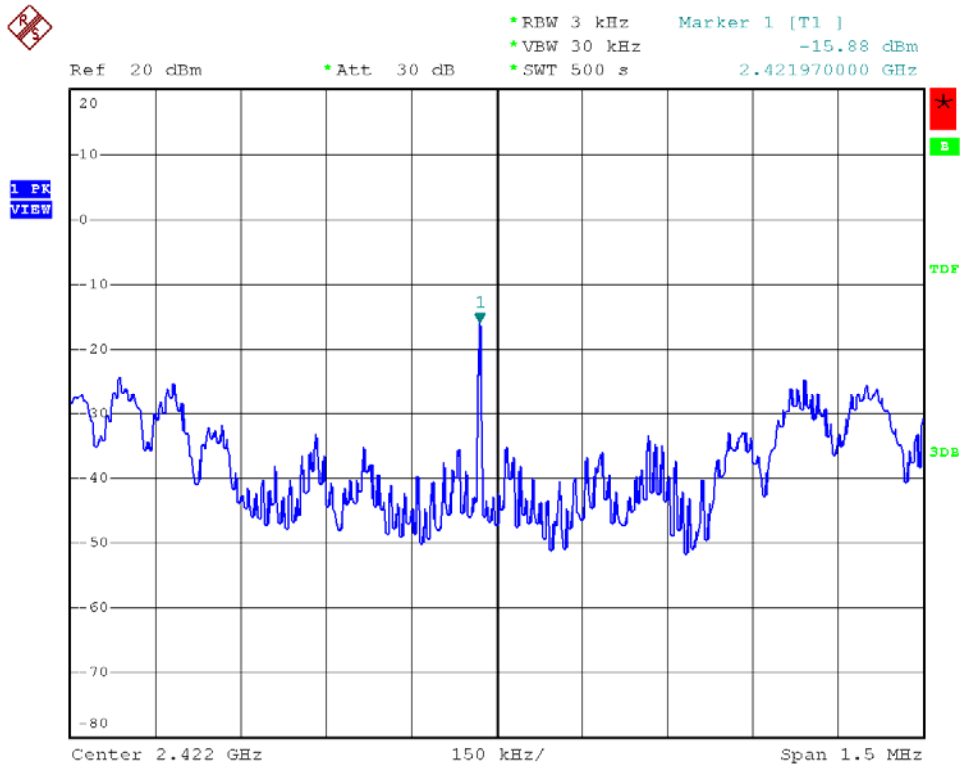



Modulation Standard: 802.11n HT40 (270Mbps)
Channel: 06

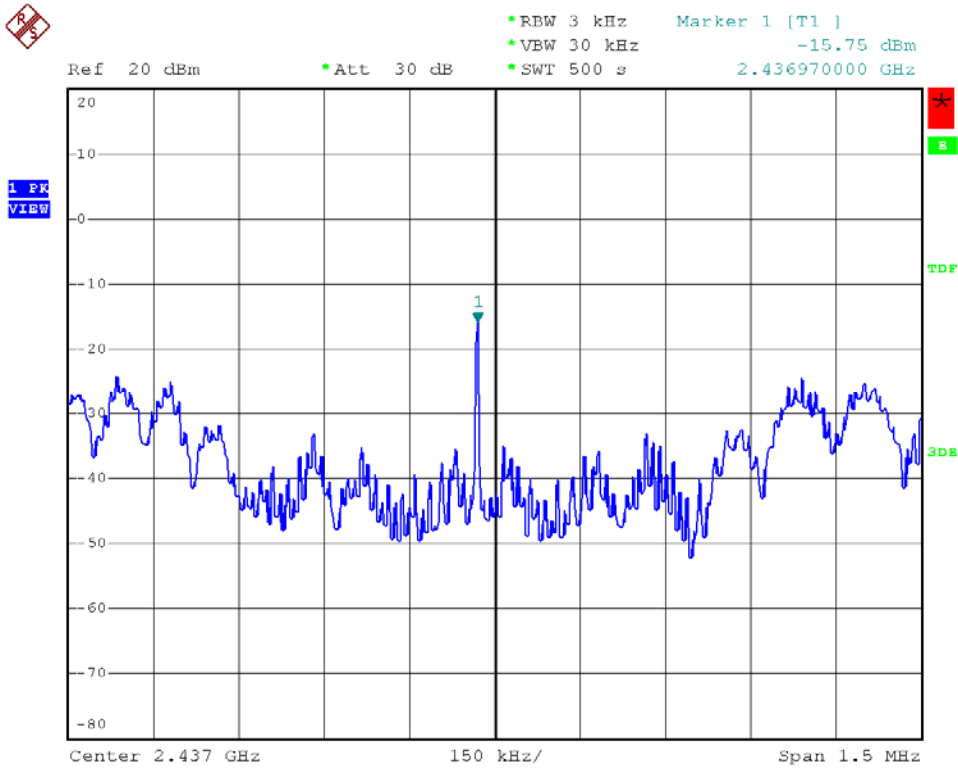

Modulation Standard: 802.11n HT40 (270Mbps)
Channel: 09

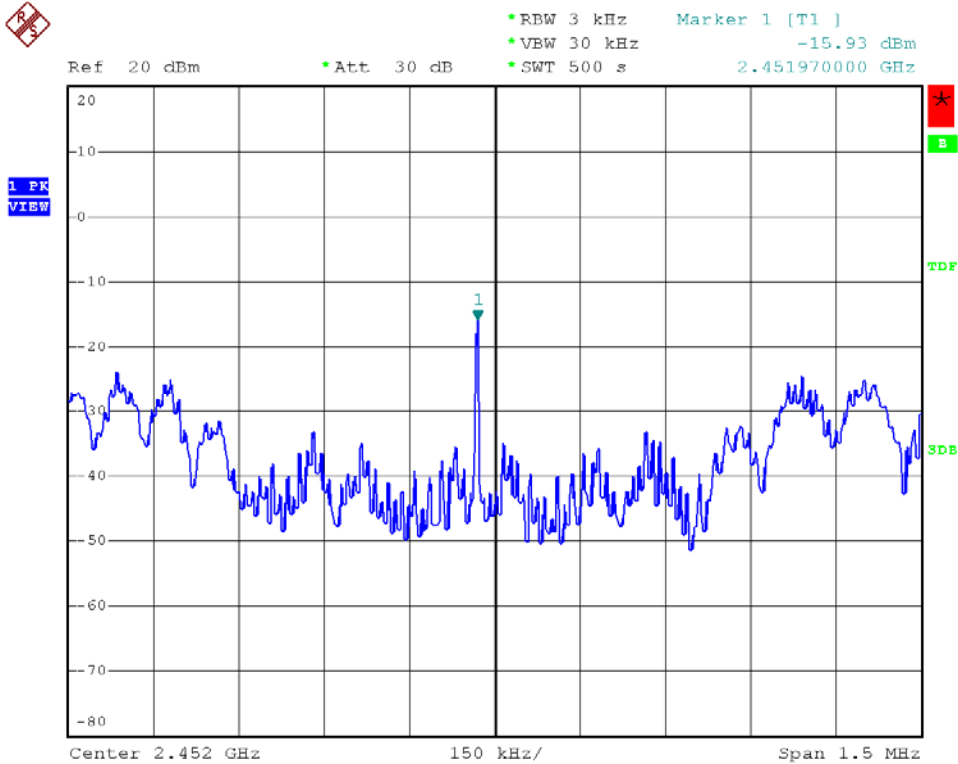



9. Band Edges Measurement

9.1 Test Limit

Below -20dB of the highest emission level of operating band (In 100 kHz Resolution Bandwidth)

9.2 Test Procedure

- The transmitter output was connected to the spectrum analyzer via a low lose cable.
- Set both RBW and VBW of spectrum analyzer to 100 KHz with convenient frequency span including 100 KHz bandwidth from band edge.
- The band edges was measured and recorded.

9.3 Test Setup Layout

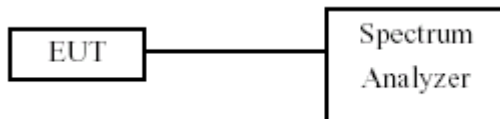

9.4 Measurement Equipment

| Instrument/Ancillary | Manufacturer | Model No. | Serial No. | Calibration Date | Valid Date |
|----------------------|--------------|-----------|------------|------------------|------------|
| Spectrum Analyzer | R&S | FSP40 | 100219 | 2010/11/05 | 2011/11/04 |

9.5 Test Result and Data

Test Date: Sep. 19, 2011

Temperature: 24°C

Atmospheric pressure: 1020 hPa

Humidity: 65%

| Modulation Standard | Channel | Frequency (MHz) | maximum value in frequency (MHz) | maximum value (dBm) |
|---------------------------|---------|-----------------|----------------------------------|---------------------|
| 802.11b (11Mbps) | 01 | 2412 | 2400.00 | -36.98 |
| | 11 | 2462 | 2484.30 | -41.49 |
| 802.11g (54Mbps) | 01 | 2412 | 2398.00 | -46.48 |
| | 11 | 2462 | 2483.90 | -41.24 |
| 802.11n HT20 (130Mbps) | 01 | 2412 | 2400.00 | -44.89 |
| | 11 | 2462 | 2513.30 | -56.02 |
| 802.11n HT40 (270Mbps) | 03 | 2422 | 2400.00 | -41.50 |
| | 09 | 2452 | 2483.50 | -51.69 |



Modulation Standard: 802.11b (11Mbps)
Channel: 01

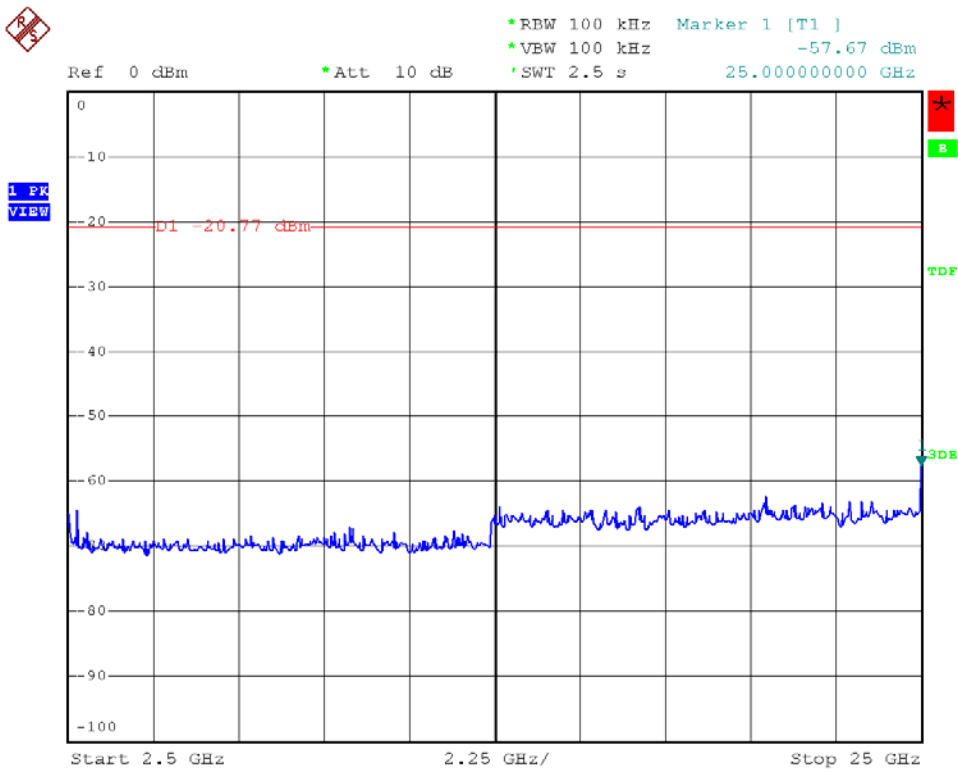
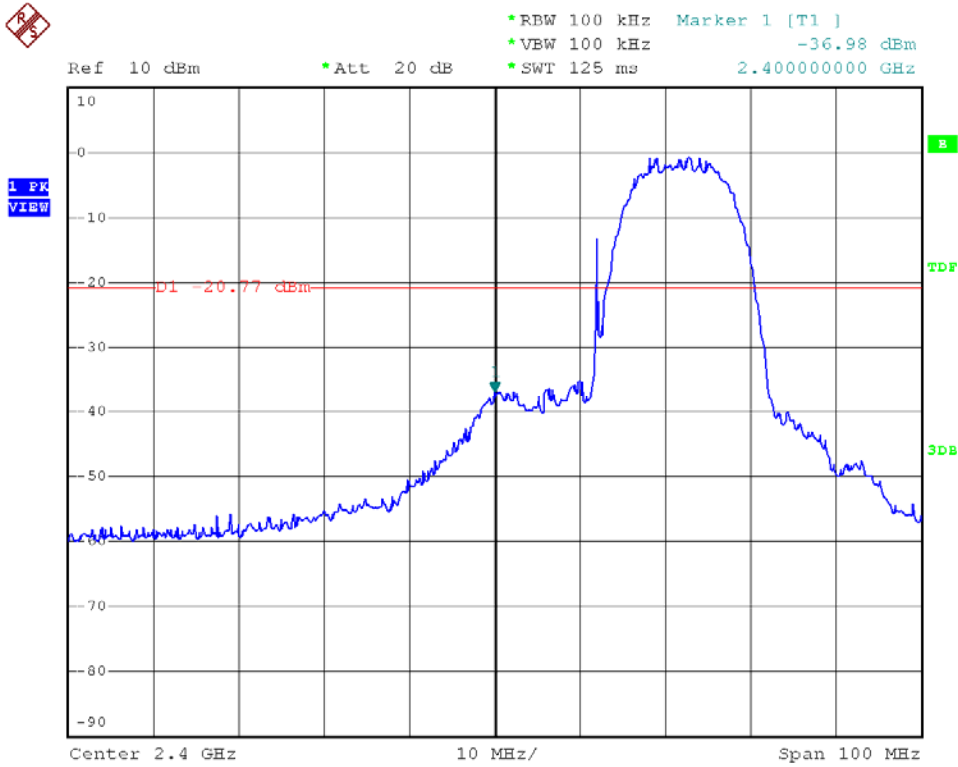



Modulation Standard: 802.11b (11Mbps)
Channel: 11

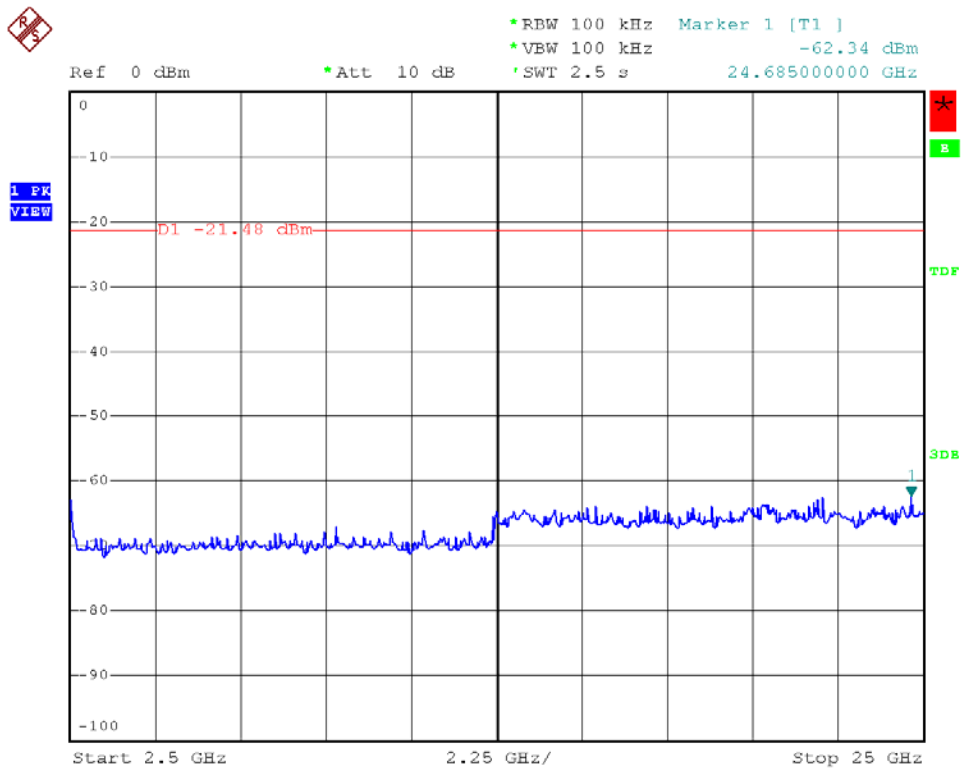
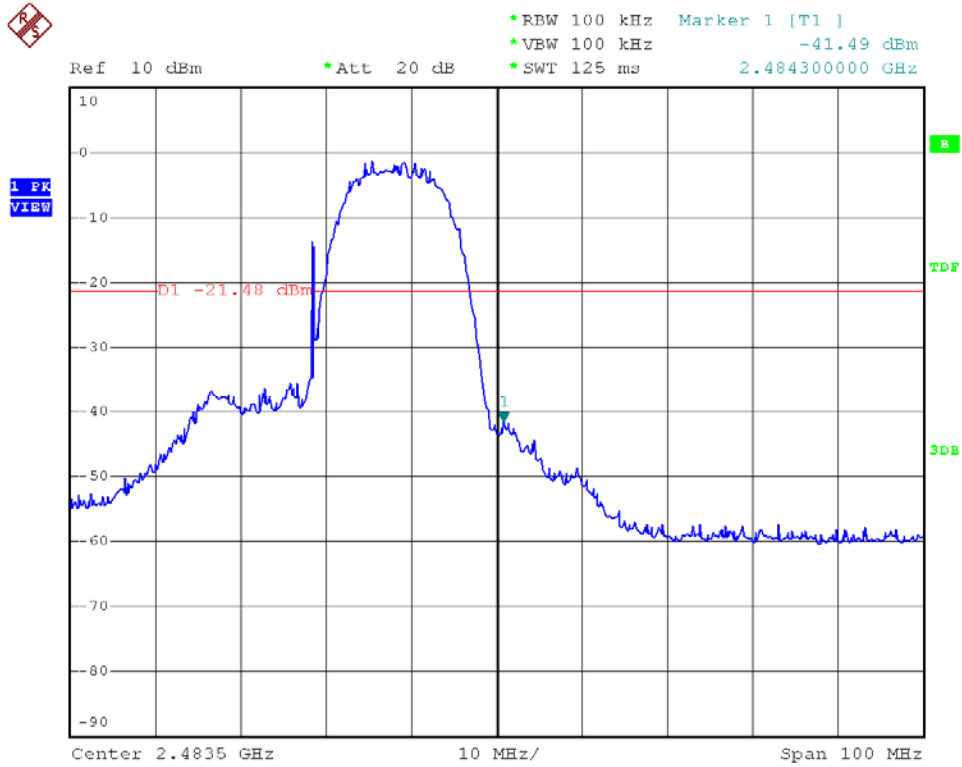



Modulation Standard: 802.11g (54Mbps)
Channel: 01

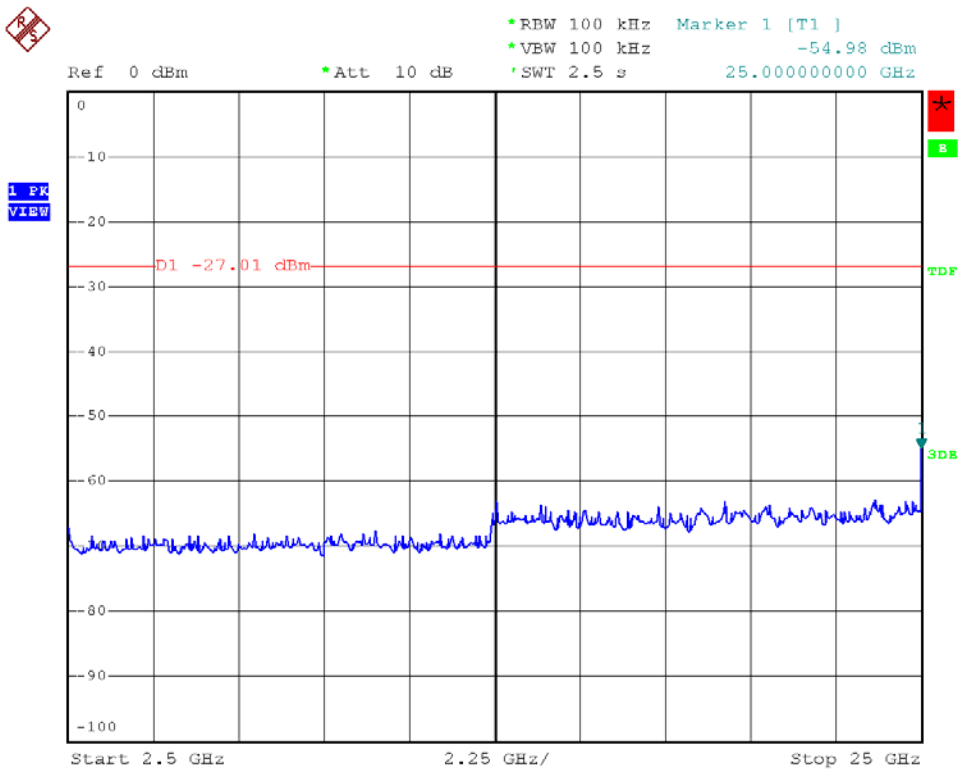
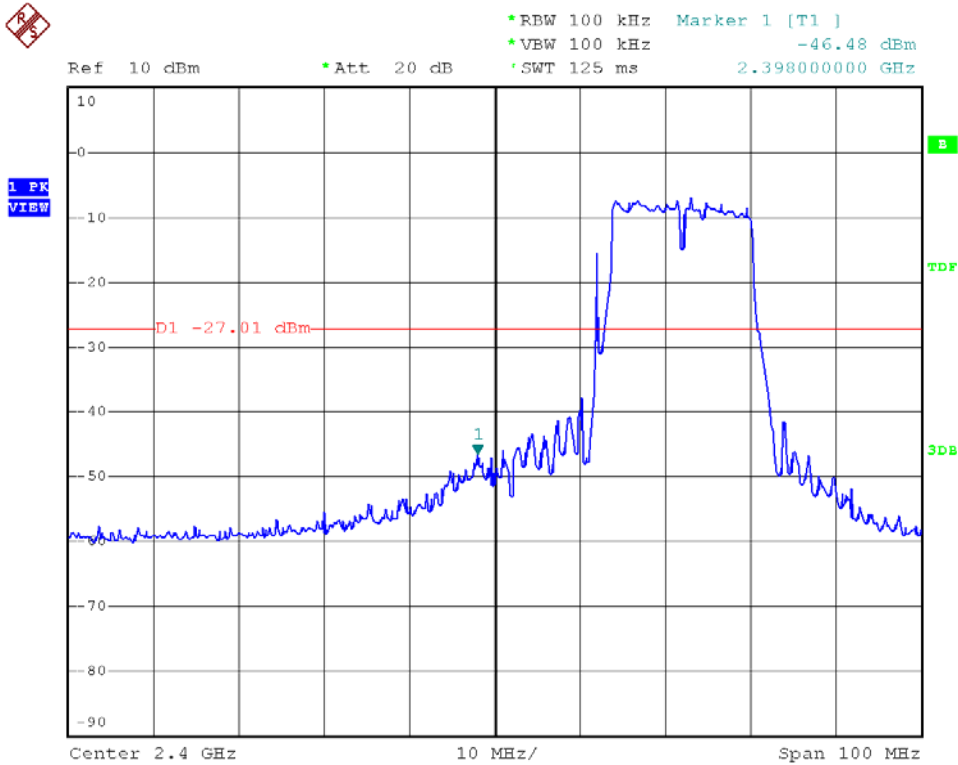



Modulation Standard: 802.11g (54Mbps)
Channel: 11

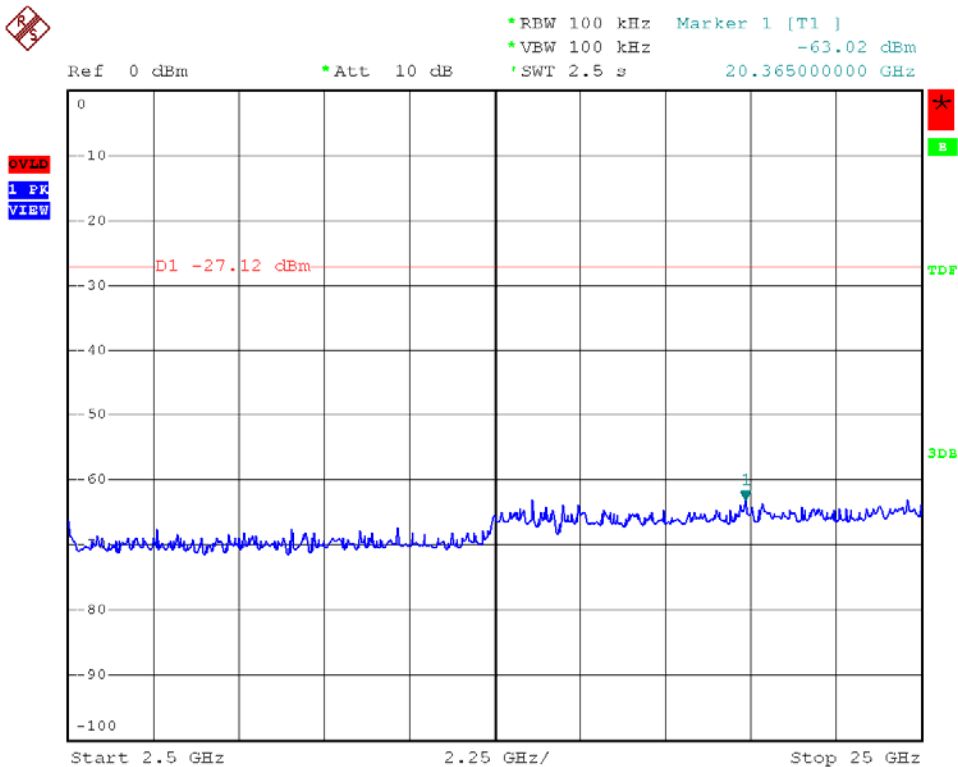
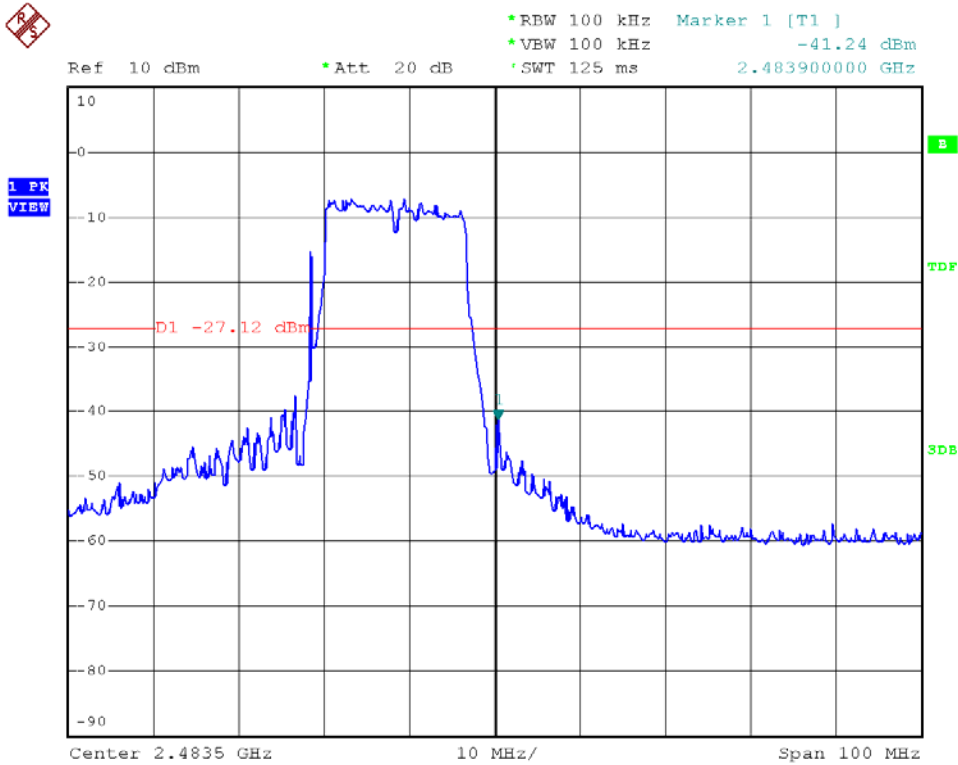



Modulation Standard: 802.11n HT20 (130Mbps)
Channel: 01

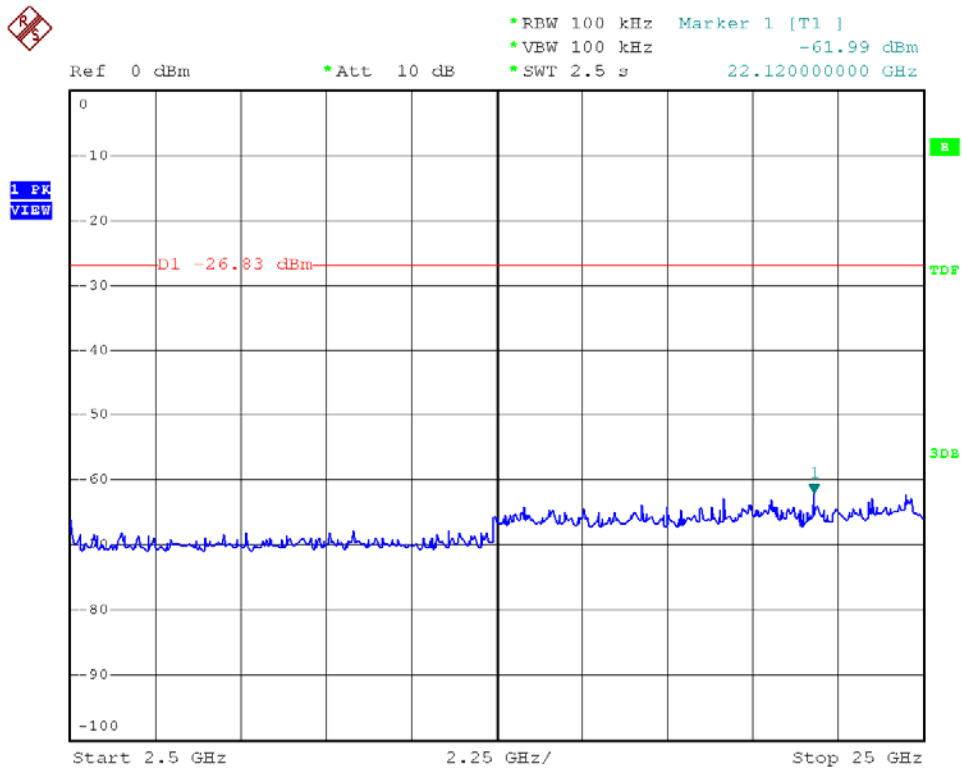
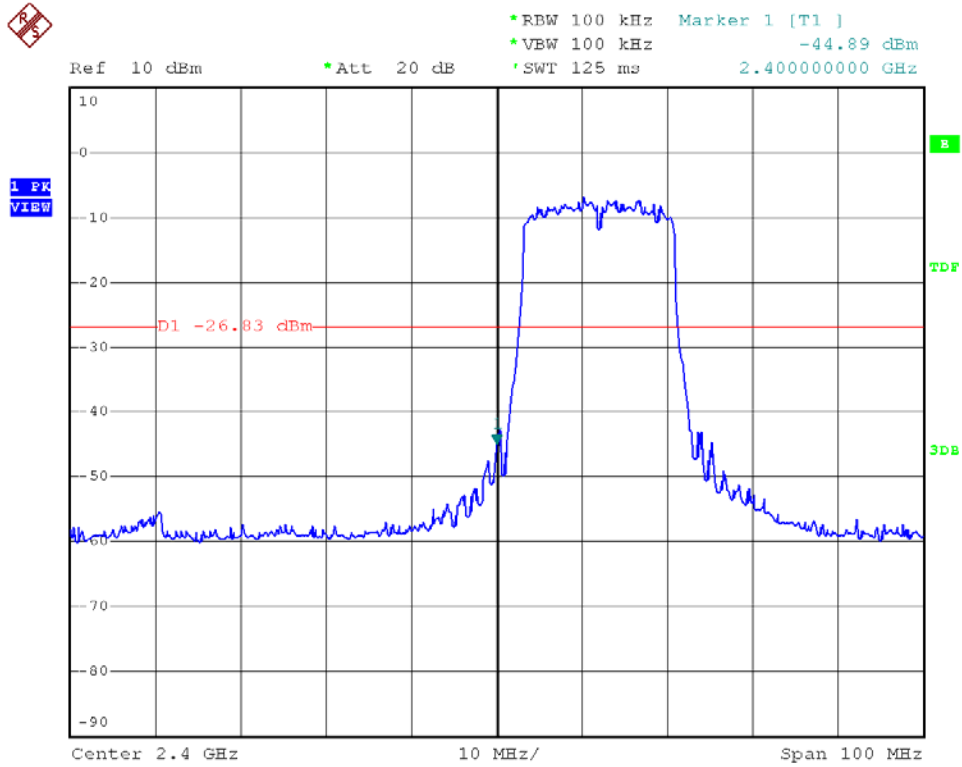



Modulation Standard: 802.11n HT20 (130Mbps)
Channel: 11

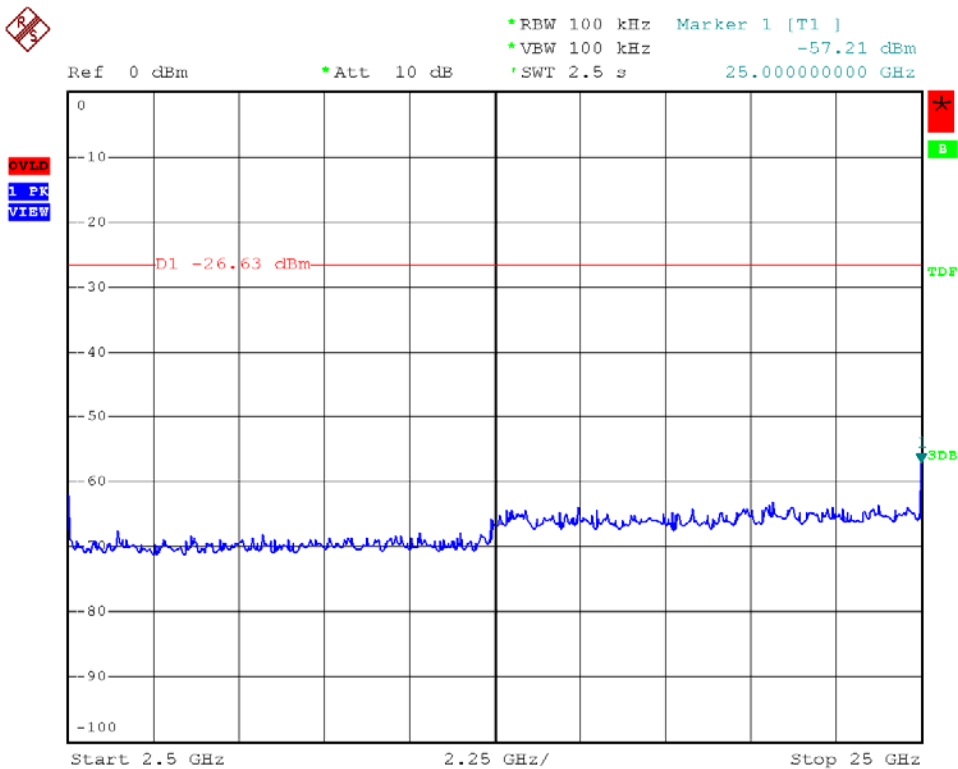
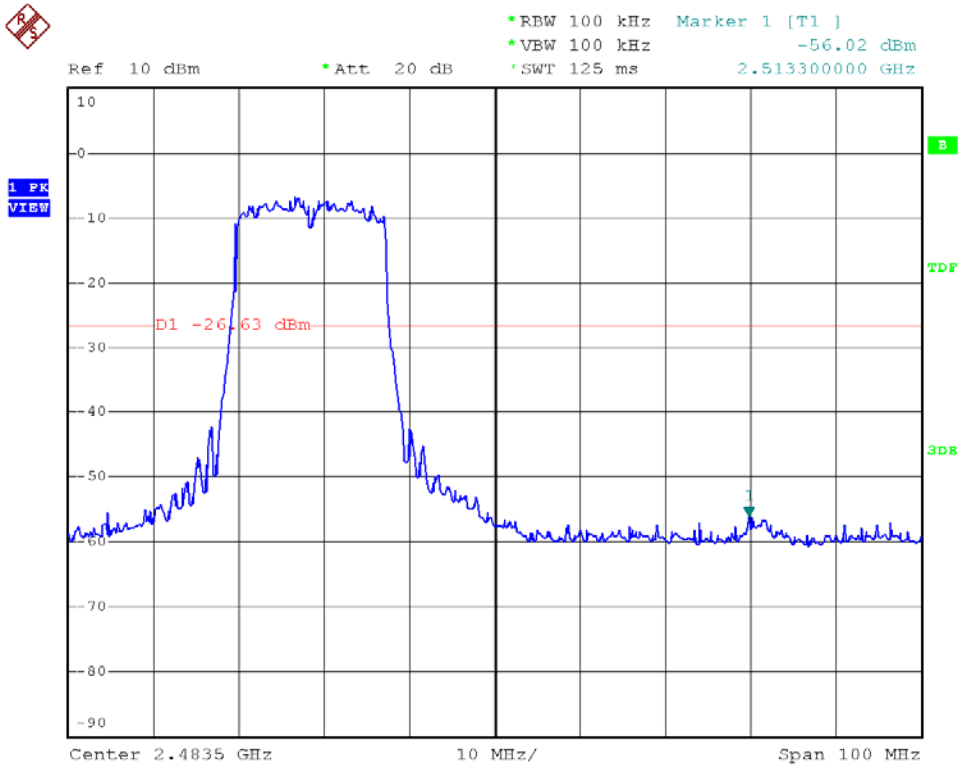



Modulation Standard: 802.11n HT40 (270Mbps)
Channel: 03

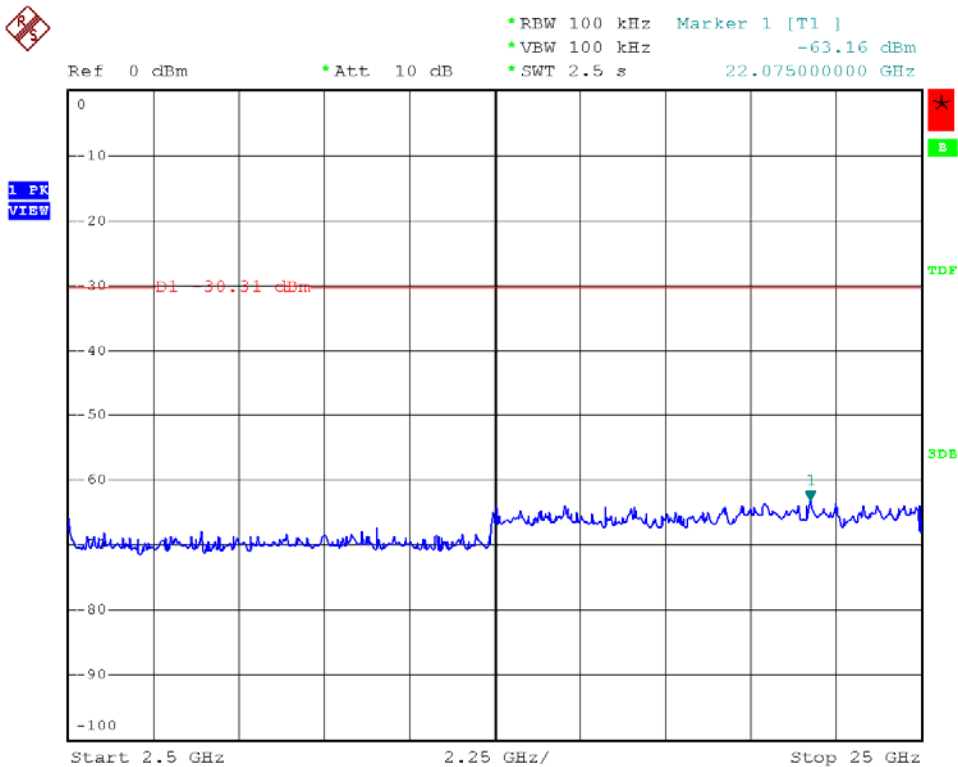
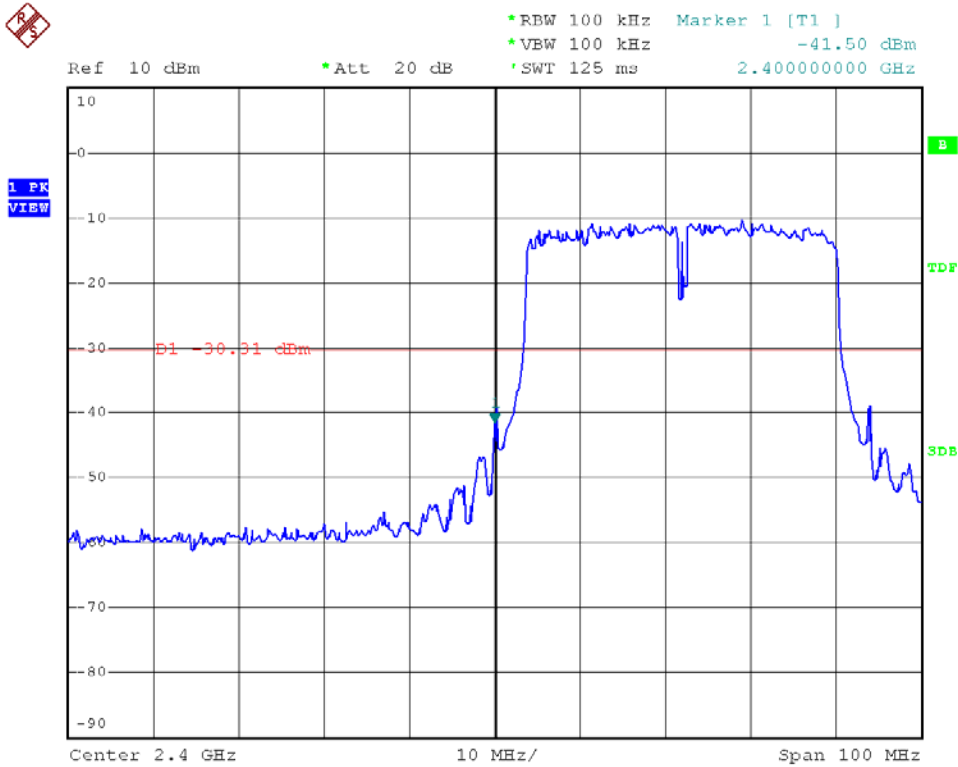



Modulation Standard: 802.11n HT40 (270Mbps)
Channel: 09

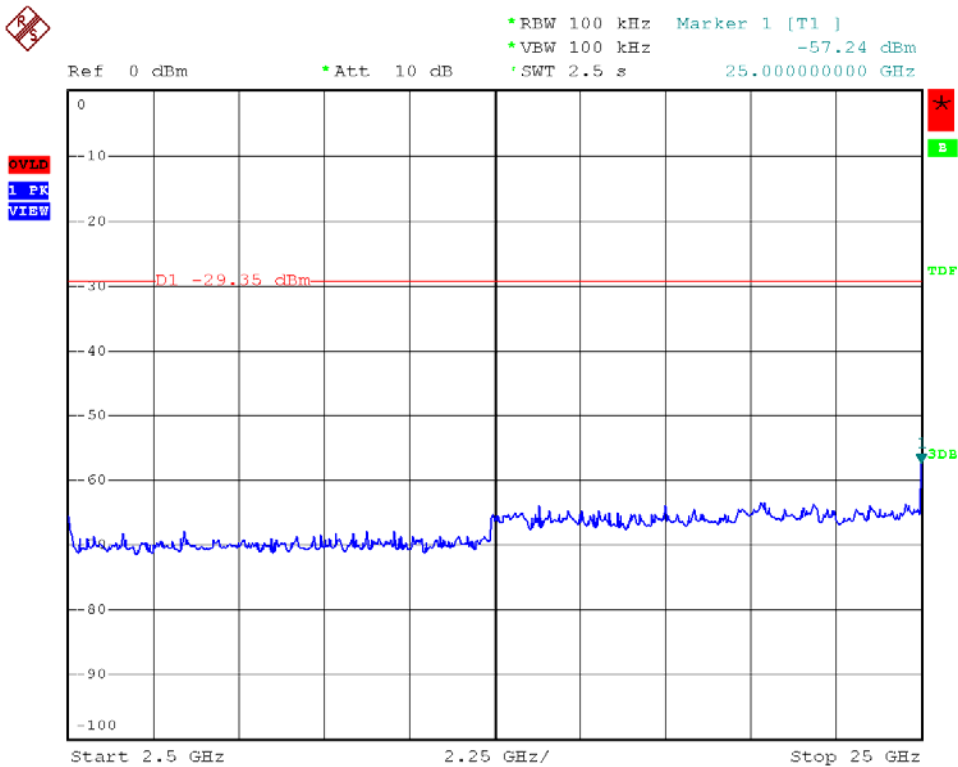
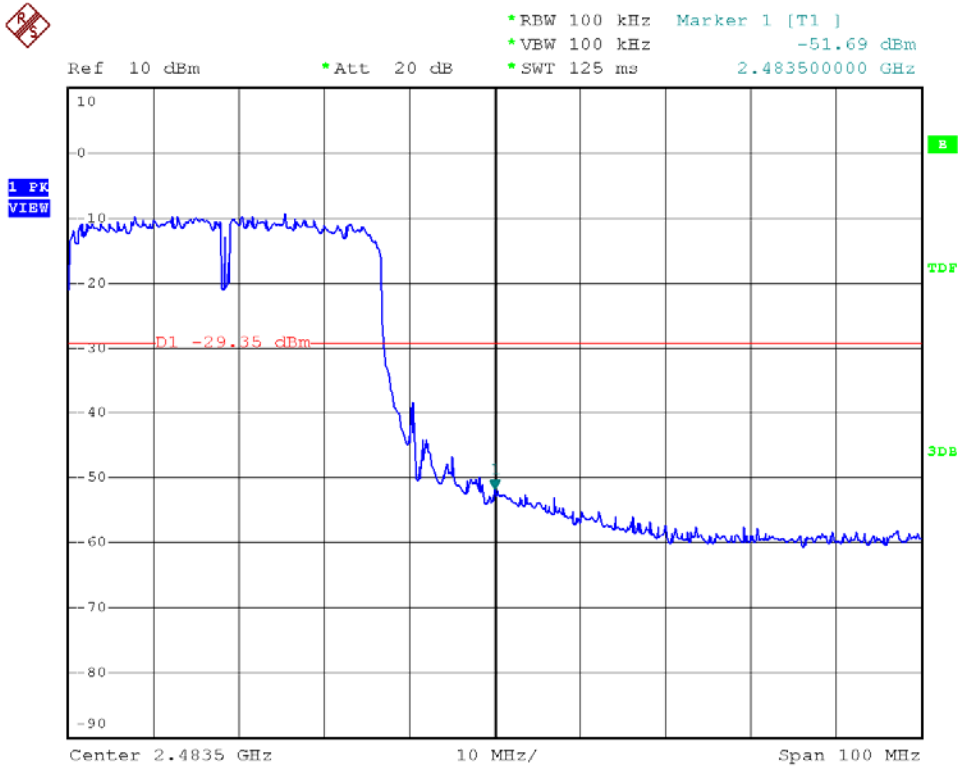



9.6 Restrict Band Emission Measurement Data

Test Date: Sep. 21, 2011

Temperature: 24°C

Atmospheric pressure: 1020 hPa

Humidity: 65%

Modulation Standard: IEEE 802.11b (11Mbps)

| Channel 1 | | | | | | Fundamental Frequency: 2412 MHz | | | | |
|-----------------|-------------|----------------------|-----------------------|-----------------|--------|---------------------------------|-----|-------------|------------|--------------|
| Frequency (MHz) | Ant-Pol H/V | Meter Reading (dBuV) | Corrected Factor (dB) | Result (dBuV/m) | Remark | Limit (dBuV/m) | | Margin (dB) | Table Deg. | Ant High (m) |
| | | | | | | Peak | Ave | | | |
| 2331.93 | H | 49.83 | 1.69 | 51.52 | Peak | 74 | 54 | -22.48 | 237 | 100 |
| ----- | H | ----- | ----- | ----- | Ave | 74 | 54 | ----- | ----- | ----- |
| 2338.05 | V | 51.97 | 2.95 | 54.92 | Peak | 74 | 54 | -19.08 | 226 | 100 |
| 2338.05 | V | 39.06 | 2.95 | 42.01 | Ave | 74 | 54 | -11.99 | 138 | 100 |
| Channel 11 | | | | | | Fundamental Frequency: 2462 MHz | | | | |
| Frequency (MHz) | Ant-Pol H/V | Meter Reading (dBuV) | Corrected Factor (dB) | Result (dBuV/m) | Remark | Limit (dBuV/m) | | Margin (dB) | Table Deg. | Ant High (m) |
| | | | | | | Peak | Ave | | | |
| 2496.50 | H | 49.64 | -0.09 | 49.55 | Peak | 74 | 54 | -24.45 | 56 | 100 |
| ----- | H | ----- | ----- | ----- | Ave | 74 | 54 | ----- | ----- | ----- |
| 2484.04 | V | 53.21 | -2.57 | 50.64 | Peak | 74 | 54 | -23.36 | 137 | 100 |
| ----- | V | ----- | ----- | ----- | Ave | 74 | 54 | ----- | ----- | ----- |

Modulation Standard: IEEE 802.11g (54Mbps)

| Channel 1 | | | | | | Fundamental Frequency: 2412 MHz | | | | |
|-----------------|-------------|----------------------|-----------------------|-----------------|--------|---------------------------------|-----|-------------|------------|--------------|
| Frequency (MHz) | Ant-Pol H/V | Meter Reading (dBuV) | Corrected Factor (dB) | Result (dBuV/m) | Remark | Limit (dBuV/m) | | Margin (dB) | Table Deg. | Ant High (m) |
| | | | | | | Peak | Ave | | | |
| 2336.52 | H | 50.25 | 1.66 | 51.91 | Peak | 74 | 54 | -22.09 | 248 | 100 |
| ----- | H | ----- | ----- | ----- | Ave | 74 | 54 | ----- | ----- | ----- |
| 2359.78 | V | 53.34 | 2.57 | 55.91 | Peak | 74 | 54 | -18.09 | 249 | 100 |
| 2359.68 | V | 42.26 | 2.58 | 44.84 | Ave | 74 | 54 | -9.16 | 114 | 100 |
| Channel 11 | | | | | | Fundamental Frequency: 2462 MHz | | | | |
| Frequency (MHz) | Ant-Pol H/V | Meter Reading (dBuV) | Corrected Factor (dB) | Result (dBuV/m) | Remark | Limit (dBuV/m) | | Margin (dB) | Table Deg. | Ant High (m) |
| | | | | | | Peak | Ave | | | |
| 2483.74 | H | 49.17 | 0.10 | 49.27 | Peak | 74 | 54 | -24.73 | 233 | 100 |
| ----- | H | ----- | ----- | ----- | Ave | 74 | 54 | ----- | ----- | ----- |
| 2484.04 | V | 54.12 | -2.57 | 51.55 | Peak | 74 | 54 | -22.45 | 103 | 100 |
| ----- | V | ----- | ----- | ----- | Ave | 74 | 54 | ----- | ----- | ----- |



Modulation Standard: IEEE 802.11n HT20 (130Mbps)

| Channel 1 | | | | | | Fundamental Frequency: 2412 MHz | | | | |
|-----------------|-------------|----------------------|-----------------------|-----------------|--------|---------------------------------|-----|-------------|------------|--------------|
| Frequency (MHz) | Ant-Pol H/V | Meter Reading (dBuV) | Corrected Factor (dB) | Result (dBuV/m) | Remark | Limit (dBuV/m) | | Margin (dB) | Table Deg. | Ant High (m) |
| | | | | | | Peak | Ave | | | |
| 2339.38 | H | 49.32 | 1.66 | 50.98 | Peak | 74 | 54 | -23.02 | 71 | 100 |
| ----- | H | ----- | ----- | ----- | Ave | 74 | 54 | ----- | ----- | ----- |
| 2359.98 | V | 53.29 | 2.57 | 55.86 | Peak | 74 | 54 | -18.14 | 108 | 100 |
| 2360.18 | V | 42.38 | 2.57 | 44.95 | Ave | 74 | 54 | -9.05 | 236 | 100 |
| Channel 11 | | | | | | Fundamental Frequency: 2462 MHz | | | | |
| Frequency (MHz) | Ant-Pol H/V | Meter Reading (dBuV) | Corrected Factor (dB) | Result (dBuV/m) | Remark | Limit (dBuV/m) | | Margin (dB) | Table Deg. | Ant High (m) |
| | | | | | | Peak | Ave | | | |
| 2487.27 | H | 49.33 | 0.04 | 49.37 | Peak | 74 | 54 | -24.63 | 257 | 100 |
| ----- | H | ----- | ----- | ----- | Ave | 74 | 54 | ----- | ----- | ----- |
| 2484.12 | V | 57.01 | -2.57 | 54.44 | Peak | 74 | 54 | -19.56 | 110 | 100 |
| 2484.12 | V | 41.00 | -2.57 | 38.43 | Ave | 74 | 54 | -15.57 | 268 | 100 |

Modulation Standard: IEEE 802.11n HT40 (270Mbps)

| Channel 3 | | | | | | Fundamental Frequency: 2422 MHz | | | | |
|-----------------|-------------|----------------------|-----------------------|-----------------|--------|---------------------------------|-----|-------------|------------|--------------|
| Frequency (MHz) | Ant-Pol H/V | Meter Reading (dBuV) | Corrected Factor (dB) | Result (dBuV/m) | Remark | Limit (dBuV/m) | | Margin (dB) | Table Deg. | Ant High (m) |
| | | | | | | Peak | Ave | | | |
| 2337.03 | H | 49.56 | 1.66 | 51.22 | Peak | 74 | 54 | -22.78 | 92 | 100 |
| ----- | H | ----- | ----- | ----- | Ave | 74 | 54 | ----- | ----- | ----- |
| 2389.36 | V | 54.07 | 2.08 | 56.15 | Peak | 74 | 54 | -17.85 | 69 | 100 |
| 2389.36 | V | 41.70 | 2.08 | 43.78 | Ave | 74 | 54 | -10.22 | 228 | 100 |
| Channel 9 | | | | | | Fundamental Frequency: 2452 MHz | | | | |
| Frequency (MHz) | Ant-Pol H/V | Meter Reading (dBuV) | Corrected Factor (dB) | Result (dBuV/m) | Remark | Limit (dBuV/m) | | Margin (dB) | Table Deg. | Ant High (m) |
| | | | | | | Peak | Ave | | | |
| 2486.40 | H | 49.06 | 0.05 | 49.11 | Peak | 74 | 54 | -24.89 | 274 | 100 |
| ----- | H | ----- | ----- | ----- | Ave | 74 | 54 | ----- | ----- | ----- |
| 2483.74 | V | 58.65 | -2.55 | 56.10 | Peak | 74 | 54 | -17.90 | 251 | 100 |
| 2483.74 | V | 45.48 | -2.55 | 42.93 | Ave | 74 | 54 | -11.07 | 96 | 100 |

Notes:

1. Result = Meter Reading + Factor
2. Factor = Antenna Factor + Cable Loss – Amplifier
3. The resolution bandwidth of test receiver/spectrum analyzer is 1MHz and video bandwidth is 3 MHz for Peak detection at frequency above 1GHz.
4. The resolution bandwidth of test receiver/spectrum analyzer is 1MHz and video bandwidth is 10 MHz for Average detection at frequency above 1GHz.



10. Restricted Bands of Operation

Only spurious emissions are permitted in any of the frequency bands listed below:

| MHz | MHz | MHz | GHz |
|---------------------|-----------------------|-----------------|-----------------|
| 0.09000 – 0.11000 | 16.42000 – 16.42300 | 399.9 – 410.0 | 4.500 – 5.250 |
| 0.49500 – 0.505** | 16.69475 – 16.69525 | 608.0 – 614.0 | 5.350 – 5.460 |
| 2.17350 – 2.19050 | 16.80425 – 16.80475 | 960.0 – 1240.0 | 7.250 – 7.750 |
| 4.12500 – 4.12800 | 25.50000 – 25.67000 | 1300.0 – 1427.0 | 8.025 – 8.500 |
| 4.17725 – 4.17775 | 37.50000 – 38.25000 | 1435.0 – 1626.5 | 9.000 – 9.200 |
| 4.20725 – 4.20775 | 73.00000 – 74.60000 | 1645.5 – 1646.5 | 9.300 – 9.500 |
| 6.21500 – 6.21800 | 74.80000 – 75.20000 | 1660.0 – 1710.0 | 10.600 – 12.700 |
| 6.26775 – 6.26825 | 108.00000 – 121.94000 | 1718.8 – 1722.2 | 13.250 – 13.400 |
| 6.31175 – 6.31225 | 123.00000 – 138.00000 | 2200.0 – 2300.0 | 14.470 – 14.500 |
| 8.29100 – 8.29400 | 149.90000 – 150.05000 | 2310.0 – 2390.0 | 15.350 – 16.200 |
| 8.36200 – 8.36600 | 156.52475 – 156.52525 | 2483.5 – 2500.0 | 17.700 – 21.400 |
| 8.37625 – 8.38675 | 156.70000 – 156.90000 | 2655.0 – 2900.0 | 22.010 – 23.120 |
| 8.41425 – 8.41475 | 162.01250 – 167.17000 | 3260.0 – 3267.0 | 23.600 – 24.000 |
| 12.29000 – 12.29300 | 167.72000 – 173.20000 | 3332.0 – 3339.0 | 31.200 – 31.800 |
| 12.51975 – 12.52025 | 240.00000 – 285.00000 | 3345.8 – 3358.0 | 36.430 – 36.500 |
| 12.57675 – 12.57725 | 322.00000 – 335.40000 | 3600.0 – 4400.0 | Above 38.6 |
| 13.36000 – 13.41000 | | | |

** : Until February 1, 1999, this restricted band shall be 0.490-0.510 MHz

10.1 Labeling Requirement

The device shall bear the following statement in a conspicuous location on the device:

This device complies with part 15 of the FCC Rules. Operation is subject to the following two conditions: (1) This device may not cause harmful interference, and (2) this device must accept any interference received, including interference that may cause undesired operation.