



Digital VTH
(Version 4.2)
Quick Start Guide

V1.1.3

Cybersecurity Recommendations

Mandatory actions to be taken towards cybersecurity

1. Change Passwords and Use Strong Passwords:

The number one reason systems get “hacked” is due to having weak or default passwords. It is recommended to change default passwords immediately and choose a strong password whenever possible. A strong password should be made up of at least 6 numbers.

2. Update Firmware

As is standard procedure in the tech-industry, we recommend keeping NVR, DVR, and IP camera firmware up-to-date to ensure the system is current with the latest security patches and fixes.

“Nice to have” recommendations to improve your network security.

1. Change Passwords Regularly

Regularly change the credentials to your devices to help ensure that only authorized users are able to access the system.

2. Physically Lock Down the Device:

Ideally, you want to prevent any unauthorized physical access to your system. The best way to achieve this is to install the recorder in a lockbox, locking server rack, or in a room that is behind a lock and key.

3. Isolate NVR and IP Camera Network

The network your NVR and IP camera resides on should not be the same network as your public computer network. This will prevent any visitors or unwanted guests from getting access to the same network the security system needs in order to function properly.

General



This document mainly introduces structure, installation process, debugging and verification process of digital VTH products.

Device Upgrade

Please don't cut off power supply during device upgrade. Power supply can be cut off only after the device has completed upgrade and has rebooted.

Safety Instructions

The following categorized signal words with defined meaning might appear in the Manual.

| Signal Words | Meaning |
|---|---|
|  CAUTION | Indicates a potential risk which, if not avoided, could result in property damage, data loss, lower performance, or unpredictable result. |
|  TIPS | Provides methods to help you solve a problem or save you time. |
|  NOTE | Provides additional information as the emphasis and supplement to the text. |

Privacy Protection Notice

As the device user or data controller, you might collect personal data of others, such as face, fingerprints, car plate number, Email address, phone number, GPS and so on. You need to be in compliance with the local privacy protection laws and regulations to protect the legitimate rights and interests of other people by implementing measures, including but not limited to: providing clear and visible identification to inform data subject the existence of surveillance area and providing related contact.

About the Guide

- The Guide is for reference only. If there is inconsistency between the Guide and the actual product, the actual product shall prevail.
- We are not liable for any loss caused by the operations that do not comply with the Guide.
- The Guide would be updated according to the latest laws and regulations of related regions. For detailed information, see the paper User's Manual, CD-ROM, QR code or our official website. If there is inconsistency between paper User's Manual and the electronic version, the electronic version shall prevail.

- All the designs and software are subject to change without prior written notice. The product updates might cause some differences between the actual product and the Guide. Please contact the customer service for the latest program and supplementary documentation.
- There still might be deviation in technical data, functions and operations description, or errors in print. If there is any doubt or dispute, please refer to our final explanation.
- Upgrade the reader software or try other mainstream reader software if the Guide (in PDF format) cannot be opened.
- All trademarks, registered trademarks and the company names in the Guide are the properties of their respective owners.
- Please visit our website, contact the supplier or customer service if there is any problem occurred when using the device.
- If there is any uncertainty or controversy, please refer to our final explanation.



- **Caution:** The user is cautioned that changes or modifications not expressly approved by the party responsible for compliance could void the user's authority to operate the equipment.
- **Note:** This equipment has been tested and found to comply with the limits for a Class B digital device, pursuant to part 15 of the FCC Rules. These limits are designed to provide reasonable protection against harmful interference in a residential installation. This equipment generates uses and can radiate radio frequency energy and, if not installed and used in accordance with the instructions, may cause harmful interference to radio communications. However, there is no guarantee that interference will not occur in a particular installation. If this equipment does cause harmful interference to radio or television reception, which can be determined by turning the equipment off and on, the user is encouraged to try to correct the interference by one or more of the following measures:
 - ◇ —Reorient or relocate the receiving antenna.
 - ◇ —Increase the separation between the equipment and receiver.
 - ◇ —Connect the equipment into an outlet on a circuit different from that to which the receiver is connected.
 - ◇ —Consult the dealer or an experienced radio/TV technician for help.

FCC RF Radiation Exposure Statement:

This equipment complies with FCC radiation exposure limits set forth for an uncontrolled environment. This equipment should be installed and operated with a minimum distance of 20cm between the radiator and any part of your body.

Important Safeguards and Warnings

The following description is the correct application method of the device. Please read the Guide carefully before use, in order to prevent danger and property loss. Strictly conform to the Guide during application and keep it properly after reading.

Operating Requirement

- Please don't place and install the device in an area exposed to direct sunlight or near heat generating device.
- Please don't install the device in a humid, dusty or fuliginous area.
- Please keep its horizontal installation, or install it at stable places, and prevent it from falling.
- Please don't drip or splash liquids onto the device; don't put on the device anything filled with liquids, in order to prevent liquids from flowing into the device.
- Please install the device at well-ventilated places; don't block its ventilation opening.
- Use the device only within rated input and output range.
- Please don't dismantle the device arbitrarily.
- The device shall be used with screened network cables.

Power Requirement

- The product shall use electric wires (power wires) recommended by this area, which shall be used within its rated specification!
- Please use power supply that meets SELV (safety extra low voltage) requirements, and supply power with rated voltage that conforms to Limited Power Source in IEC60950-1. For specific power supply requirements, please refer to device labels.
- Appliance coupler is a disconnecting device. During normal use, please keep an angle that facilitates operation.

Table of Contents

| | |
|--|-------------------------------------|
| Cybersecurity Recommendations | I |
| Foreword | II |
| Important Safeguards and Warnings | IV |
| 1 Product Structure | 1 |
| 1.1 Front Panel | 1 |
| 1.2 Rear Panel Port | 2 |
| 1.2.1 VTH5221 Series /VTH5241 Series..... | 2 |
| 1.2.2 VTH5221E-H/VTH5221EW-H | 2 |
| 1.2.3 VTH15 Series Type A/Type B/Type CH | Error! Bookmark not defined. |
| 1.2.4 VTH5222CH/VTH5222CHW-2 | 3 |
| 1.2.5 VTH1660CH..... | 4 |
| 1.2.6 VTH2221A..... | 4 |
| 2 Installation and Debugging | 6 |
| 2.1 Installation | 6 |
| 2.1.1 Surface Installation..... | 6 |
| 2.1.2 Installation with 86 Box | 7 |
| 2.1.3 Desktop Installation with Bracket | 7 |
| 2.2 Debugging | 8 |
| 2.2.1 VTO Settings..... | 8 |
| 2.2.2 VTH Settings | 13 |
| 2.3 Debugging Verification | 18 |
| 2.3.1 VTO Calls VTH..... | 18 |
| 2.3.2 VTH Monitors VTO..... | 19 |

1

Product Structure

1.1 Front Panel

Different models of devices may have different front panel dimensions and key types, but keys or indicators with the same silkscreen or icon have the same function. Please refer to Table 1-1 for details.









| Icon or Silkscreen | Name | Description |
|---|-------------------|--|
|  | SOS | Press this key to call the Call Center in case of emergency. |
|  | Menu | Press this key to return to main menu. |
|  | Call | <ul style="list-style-type: none">• In case of incoming call, press this key to answer the call.• During talk, press this key to hang up.• During monitoring, press this key to speak to unit VTO, villa VTO, fence station and verifying VTO.• During speaking, press this key to exit speaking. |
|  | Monitor | <ul style="list-style-type: none">• In standby mode, press this key to monitor the main VTO.• During monitoring, press this key to exit monitoring. |
|  | Unlock | In case of incoming call, talk, monitoring and speaking of VTO, press this key to unlock corresponding VTO. |
|  | Message indicator | If this indicator turns on, it represents that there are unread messages. |
|  | Power indicator | If this indicator turns on in green, it represents normal power supply. |
| Network | Network indicator | <ul style="list-style-type: none">• If this indicator turns on, it represents normal communication with VTO.• If this indicator turns off, it represents abnormal communication with VTO. |
| DND | DND indicator | If this indicator turns on in green, it represents that DND function is enabled.  NOTE For DND settings, please scan QR code on the front cover, and refer to the user's manual. |

Table 1-1

1.2 Rear Panel Port

1.2.1 VTH5221 Series /VTH5241 Series

VTH5221 series and VTH5241 series have different port positions at the rear panel, but the same port provides the same function. Taking VTH5221 as an example, specific functions of ports are introduced, as shown in Figure 1-1.

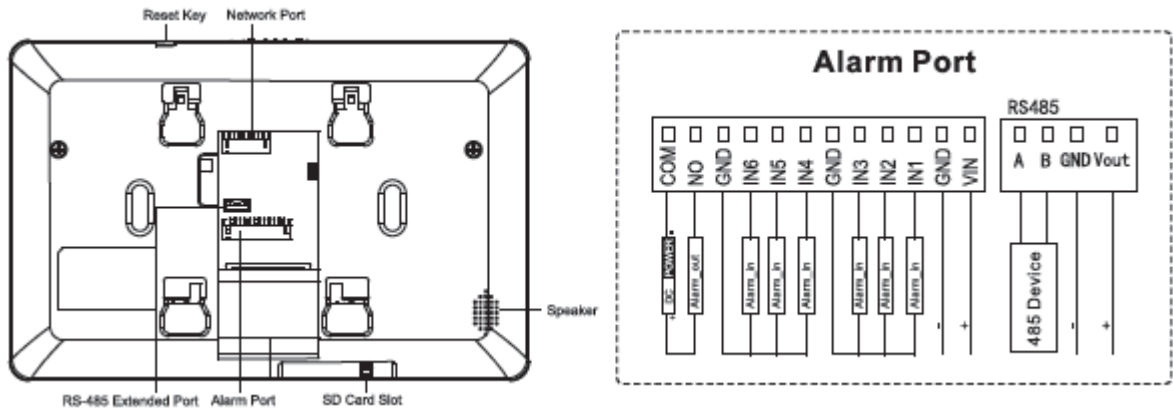

Figure 1-1

1.2.2 VTH5221E-H/VTH5221EW-H

Rear panel of VTH5221E-H/VTH5221EW-H is shown in Figure 1-2.

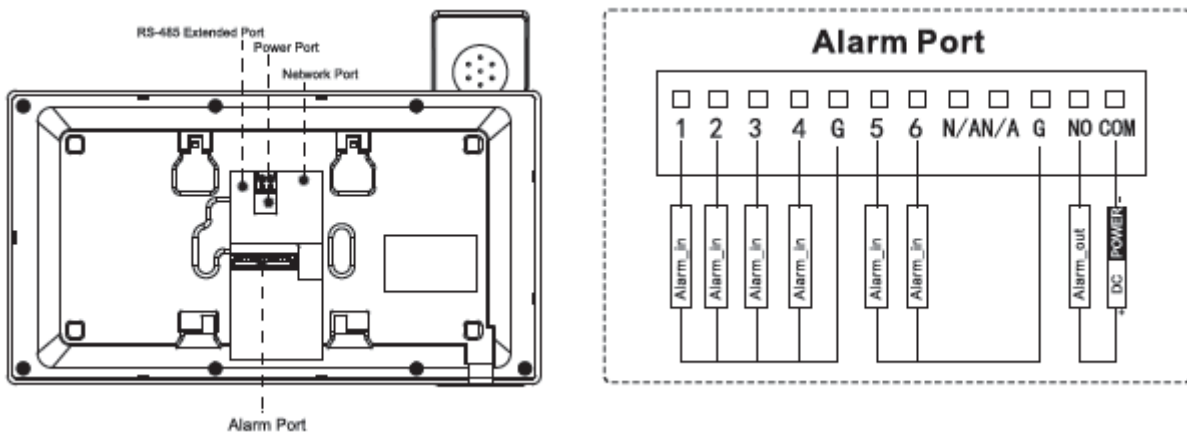

Figure 1-2

1.2.3 VTH15XX-S2 Series Type B/Type CH & VTH15XX Series Type B/Type CH

In VTH15XX-S2 type CH series, different types of digital VTH have different port positions, but the same port provides the same function. Taking VTH1550CH-S2 as an example, specific functions of ports are introduced, as shown in Figure 1-3.

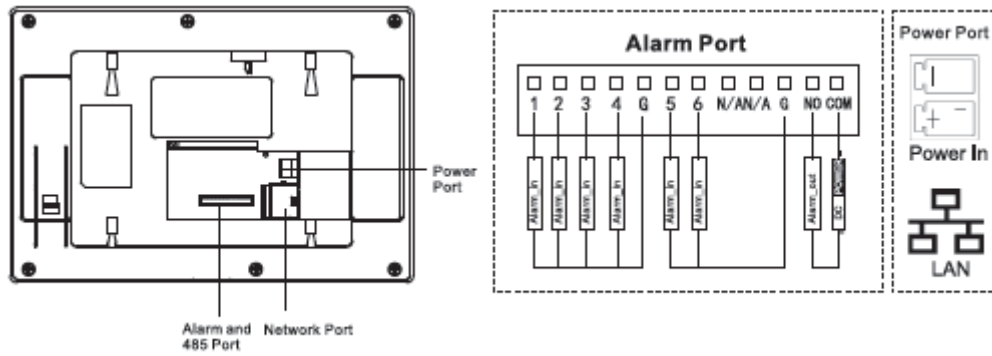

Figure 1-3

In VTH15XX-S2 type B series, different types of digital VTH have different port positions, but the same port provides the same function. Taking VTH1560B-S2 as an example, specific functions of ports are introduced, as shown in Figure 1-4.

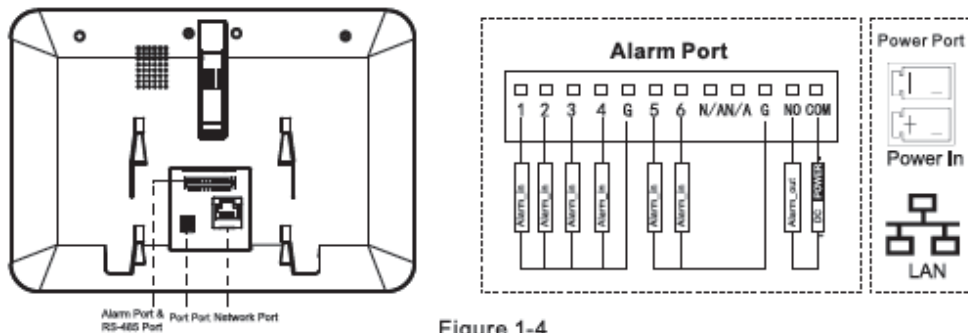

Figure 1-4

In VTH15XX type CH series, different types of digital VTH have different port positions, but the same port provides the same function. Taking VTH1550CH as an example, specific functions of ports are introduced, as shown in Figure 1-5.

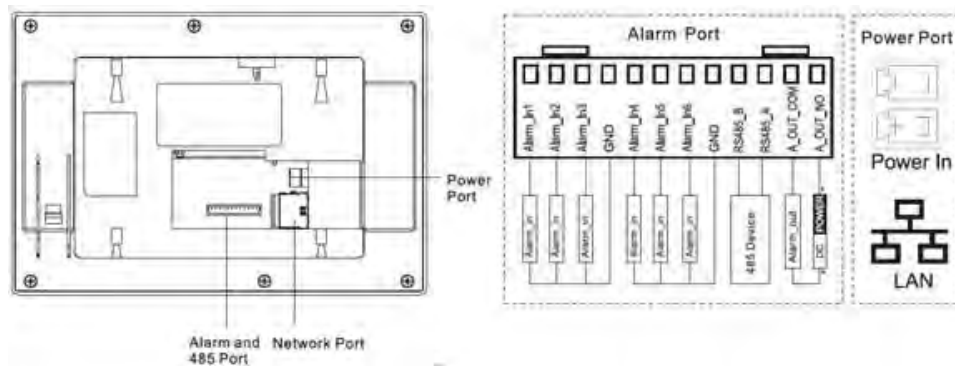

Figure 1-5

In VTH15XX type B series, different types of digital VTH have different port positions, but the same port provides the same function. Taking VTH1560B as an example, specific functions of ports are introduced, as shown in Figure 1-6.

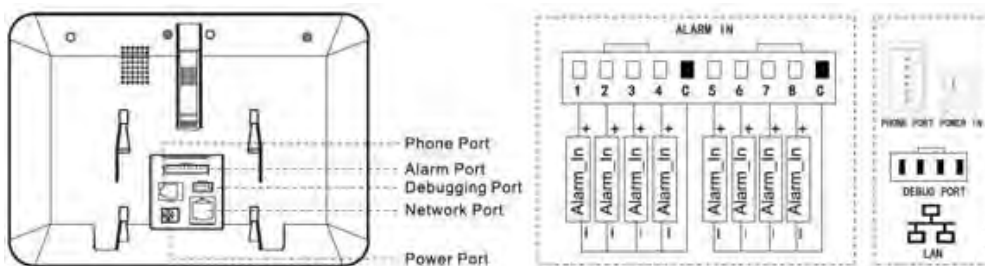

Figure 1-6

1.2.4 VTH5222CH/VTH5222CHW-2

Except different numbers of 2-wire port, VTH5222CH and VTH5222CHW-2 are the same in other aspects. VTH5222CH has 1 group of 2-wire port, while VTH1550CHW-2 has 3 groups of 2-wire port. VTH5222CH is shown in Figure 1-7.

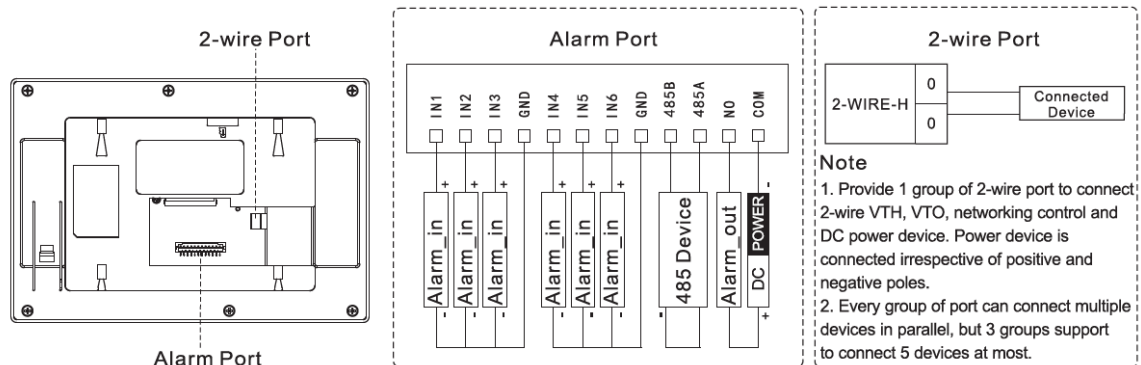

Figure 1-7

1.2.5 VTH1660CH

Its ports are described in Figure 1-8.

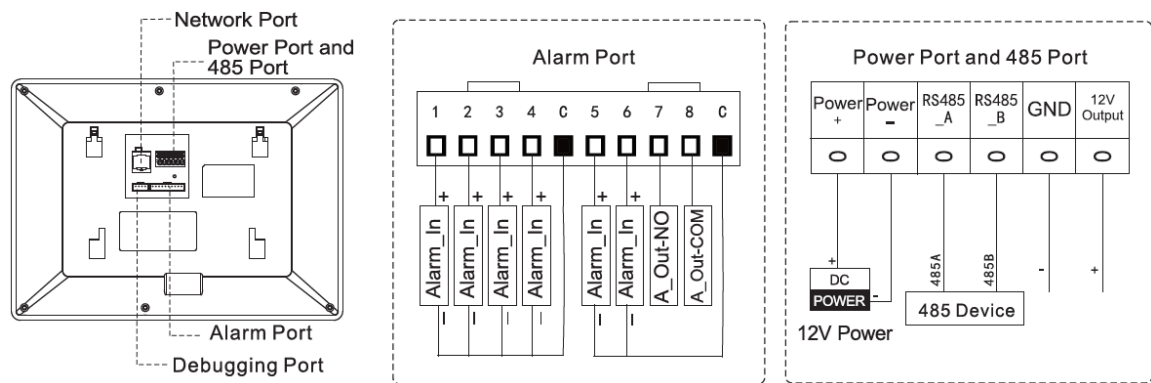

Figure 1-8

1.2.6 VTH2221A/VTH2221A-S2

Its ports are described in Figure 1-9.

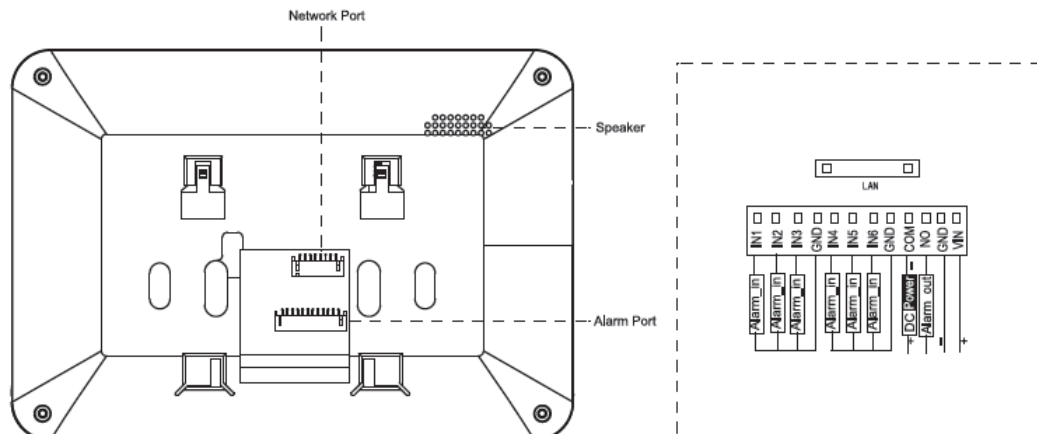

Figure 1-9

1.2.7 VTH2421FB/VTH2421FS

Its ports are described in Figure 1-9.

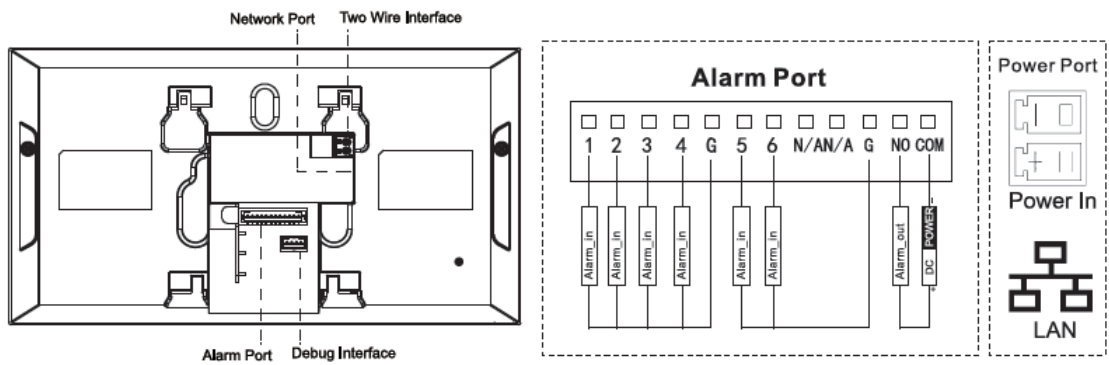

Figure 1-9

2 Installation and Debugging

2.1 Installation



CAUTION

- Don't install VTH in bad environment, such as condensation, high temperature, stained, dusty, chemically corrosive and direct sunshine environment.
- In case of abnormality after power on, please pull out network cable and cut off power supply at once. Power on after troubleshooting.
- Engineering installation and debugging shall be done by professional teams. Please don't dismantle or repair arbitrarily in case of device failure. Please contact after-sales department.
- It is suggested that installation height of device central point shall be 1.4cm~1.6cm above the ground.

2.1.1 Surface Installation

Directly install the device with a bracket onto a wall, which is suitable for all types of devices. Take "VTH1550CH" for example.

Step 1 Drill holes in the wall according to hole positions of the bracket.

Step 2 Fix installation bracket directly onto the wall with screws.

Step 3 Put the device into installation bracket from top down.

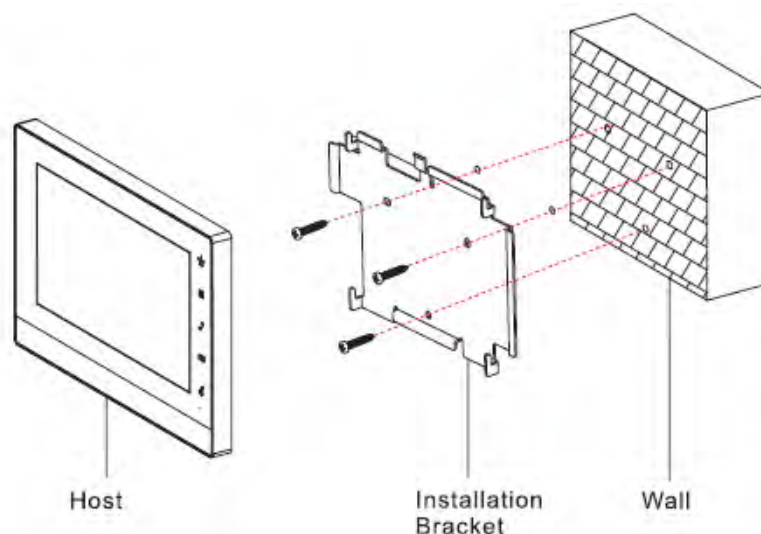

Figure 2-1

2.1.2 Installation with 86 Box

Install the device with 86 box, which is suitable for all types of devices. Take “VTH1560B/BW” for example.

Step 1 Embed 86 box into a wall at a proper height.

Step 2 Fix installation bracket onto 86 box with screws.

Step 3 Put the device into installation bracket from top down.

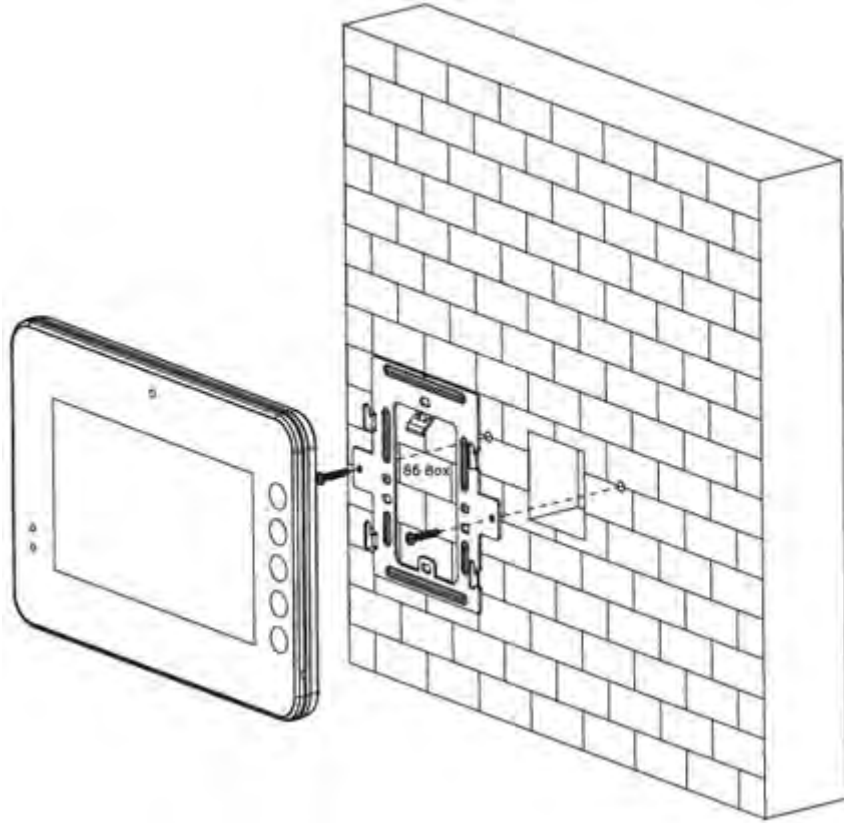

Figure 2-2

2.1.3 Desktop Installation with Bracket

Install the device with bracket on the desktop, which only applies to handset VTH. Take “VTH5221E-H” for example.

Step 1 With two M3×6 cross recessed countersunk head screws, tighten the metal bracket onto the top two nuts of desktop bracket.

Step 2 Please connect wire by reference to Figure 1-2.

Step 3 After wiring, guide the wire through wire outlet in the rear or at the bottom of desktop bracket.

Step 4 Put the handset VTH along slot at the top of metal bracket, and install it into the bracket.

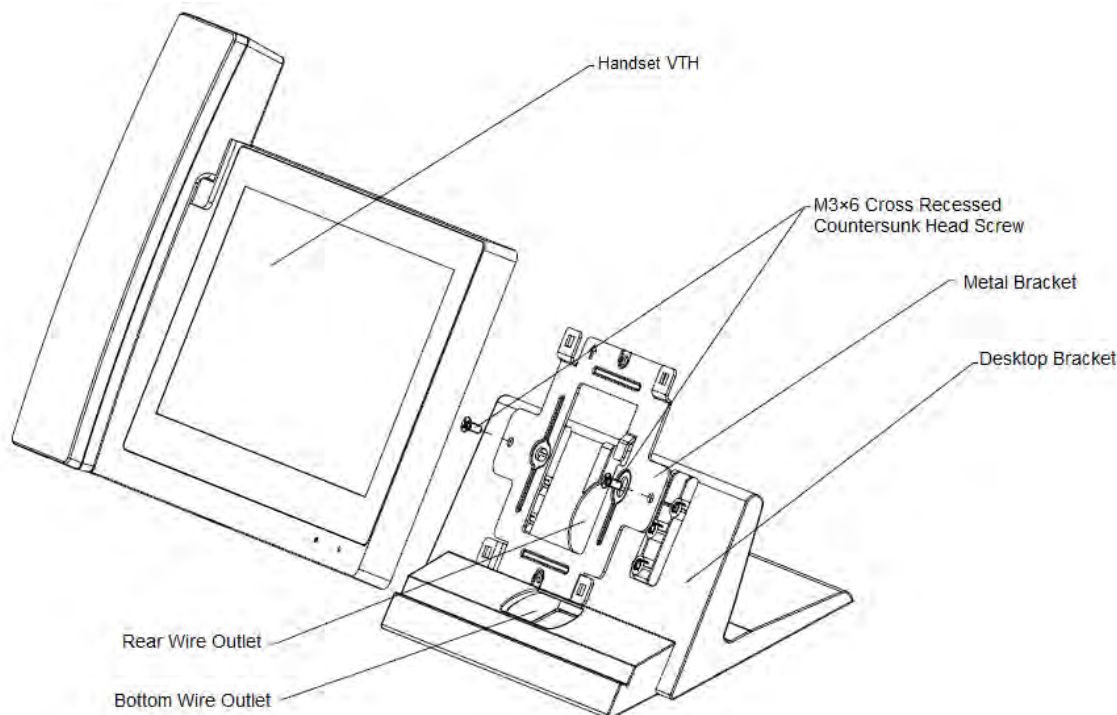

Figure 2-3

2.2 Debugging

CAUTION

Carry out debugging to ensure that the device can realize basic network access, call and monitoring functions after installation. Before debugging, please check whether the following work has been completed.

- Check whether there is short circuit or open circuit. Power on the device only after the circuit is confirmed to be normal.
- IP and no. of every VTO and VTH have been planned.
- Ensure deployment position of SIP server.
- Please scan QR code on the cover for details.

Set VTO info and VTH info at WEB interface of every VTO, set VTH info, network info and VTO info on every VTH, and thus realize video intercom function.

2.2.1 VTO Settings

VTO interfaces of different models might be different, and the actual interface shall prevail.

For the first time, please initialize and modify login password.

NOTE

Please ensure that default IP addresses of PC and VTO are in the same network segment. Default IP address of VTO is 192.168.1.110.

Step 1 Power on the device, and enter default IP address of VTO at the address bar of PC browser. The system displays “Device Init” interface, as shown in Figure 2-4.

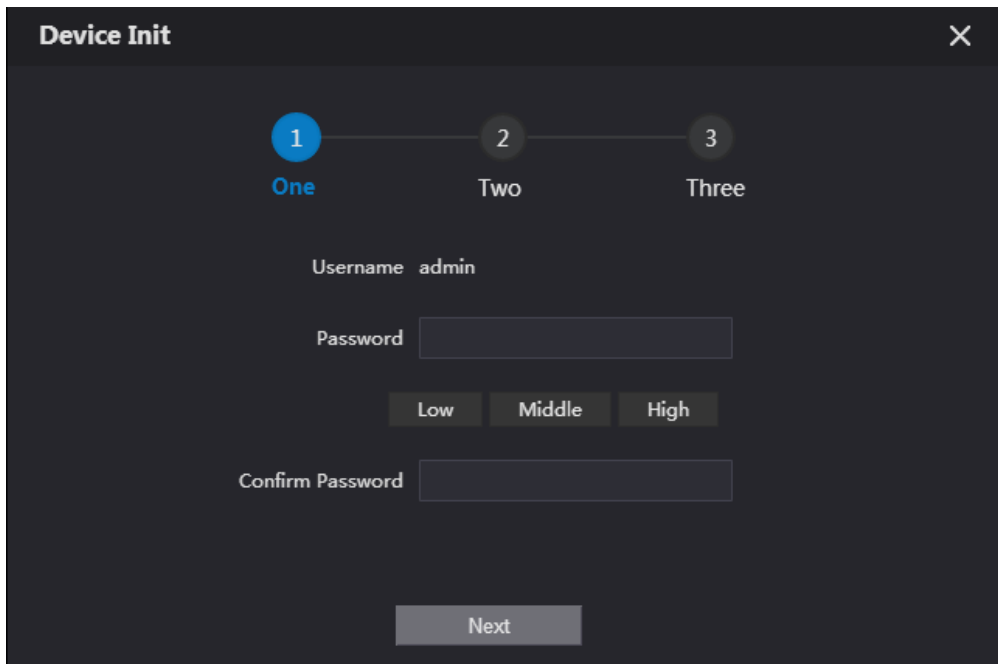

Figure 2-4

Step 2 According to interface prompt, enter “Password” and “Confirm Password”, and click “Next”. Select “Email” and enter your Email address. This Email address is used to reset the password, so it is recommended that it should be set.

Step 3 Enter default address in the browser to login WEB interface.

 **NOTE**

Default username is admin. Password is the new one set during initialization.

Step 4 Select “Network Setting > Basic”.

The system displays “TCP/IP” interface, as shown in Figure 2-5.

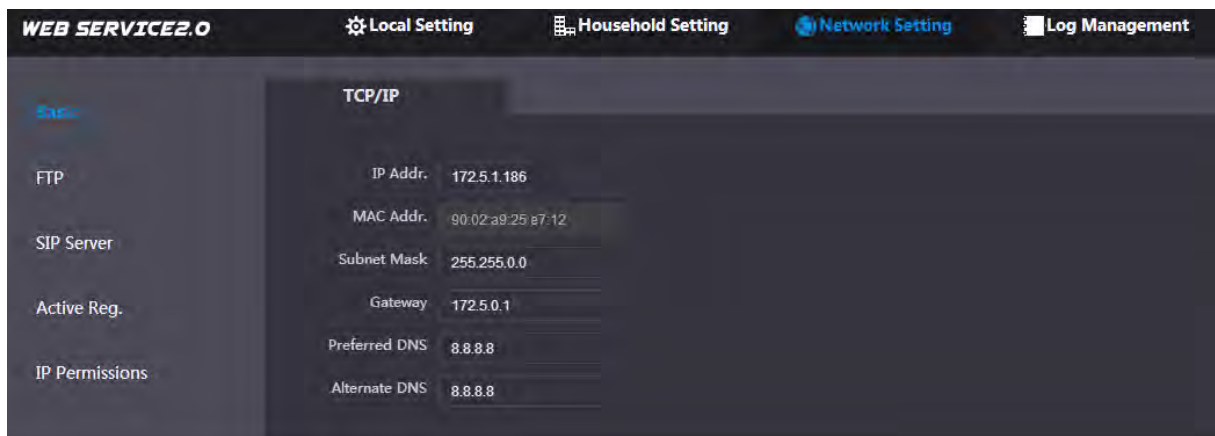

Figure 2-5

Step 5 Enter the planned “IP Address”, “Subnet Mask” and “Gateway”, and click “OK”. After modification is completed, VTO reboots automatically, while the following two cases occur at WEB interface.

- If PC is in the planned network segment, WEB interface jumps to new IP login interface automatically.
- If PC is not in the planned network segment, login will be failed. Please add PC to the planned network segment and login WEB interface again.

Step 6 Login WEB interface again; select “Local Setting > Basic”.

The system displays “Device Properties” interface, as shown in Figure 2-6.

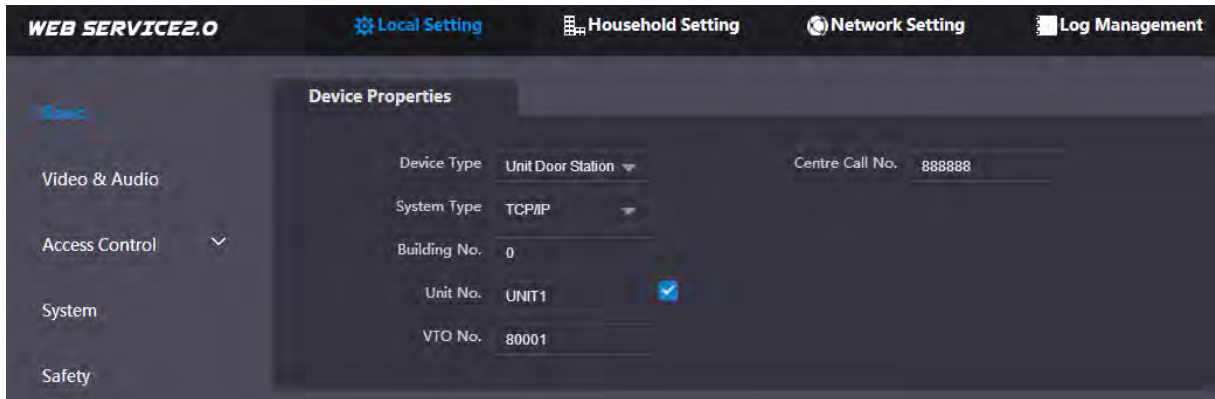

Figure 2-6

- 1) Select system type as “TCP/IP”.
- 2) Click “OK” to save the settings.

Reboot the device manually, or wait for auto reboot and put the settings into effect.

Step 7 Login WEB interface again; select “Network Setting > SIP Server”.

The system displays “SIP Server” interface, as shown in Figure 2-7.

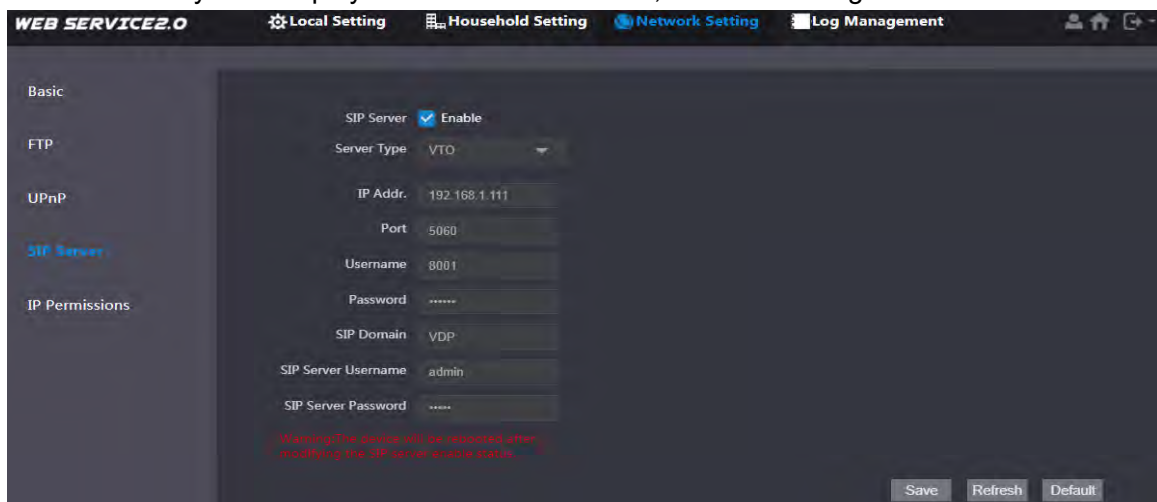

Figure 2-7

- 1) Select server type.
 - ◇ When this VTO or another VTO works as SIP server, select “Server Type” to be “VTO”. It applies to a scenario where there is only one unit.
 - ◇ When the platform (Express/DSS) works as SIP server, select “Server Type” to be “Express/DSS”. It applies to a scenario where there are multiple buildings or multiple units.
- 2) Set VTO number and click “OK” to save config.

NOTE

- When the platform works as SIP server, if it is necessary to set “Building No.” and “Building Unit No.”, please enable “Support Building” and “Support Unit” and set them.
- After VTO is set to be SIP server and configured, group call function will appear at the interface. To realize group call, please select “Enable” after the group call.

Step 8 Select “Network Setting > SIP Server”.

The system displays “SIP Server” interface, as shown in Figure 2-8.

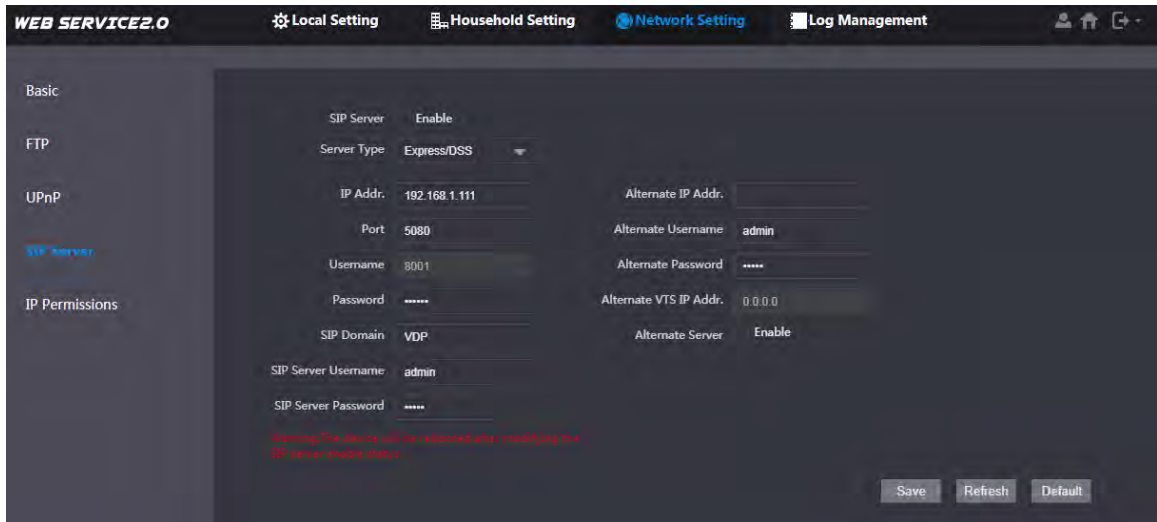

Figure 2-8

- This VTO works as SIP server.
Select “SIP Server Enable”, and click “OK” to save config. The VTO reboots automatically.
- Another VTO or platform works as SIP server.
Set parameters by reference to Table 2-1 and click “OK”. The VTO reboots automatically.

| Parameter | Description |
|-------------------------|--|
| IP Address | IP address of SIP server. |
| Port | <ul style="list-style-type: none"> • It is 5060 by default when another VTO works as SIP server. • It is 5080 by default when the platform works as SIP server. |
| Username/Password | Use default value. |
| SIP Domain | <ul style="list-style-type: none"> • It shall be VDP when another VTO works as SIP server. • It can be null or keep default value when the platform works as SIP server. |
| Login Username/Password | Username and password to login SIP server. |

Table 2-1

 NOTE

- VTO settings have been completed if the platform or another VTO works as SIP server.
- If this VTO works as SIP server, “VTO No. Management” and “Room No. Management” appears in the left parameter tab. Please add VTO and VTH by reference to “Step 9” and “Step 10”.

Step 9 (Optional) Login web interface again; select “Household Setting > VTO No. Management”.

The system displays “VTO No. Management” interface, as shown in Figure 2-9.

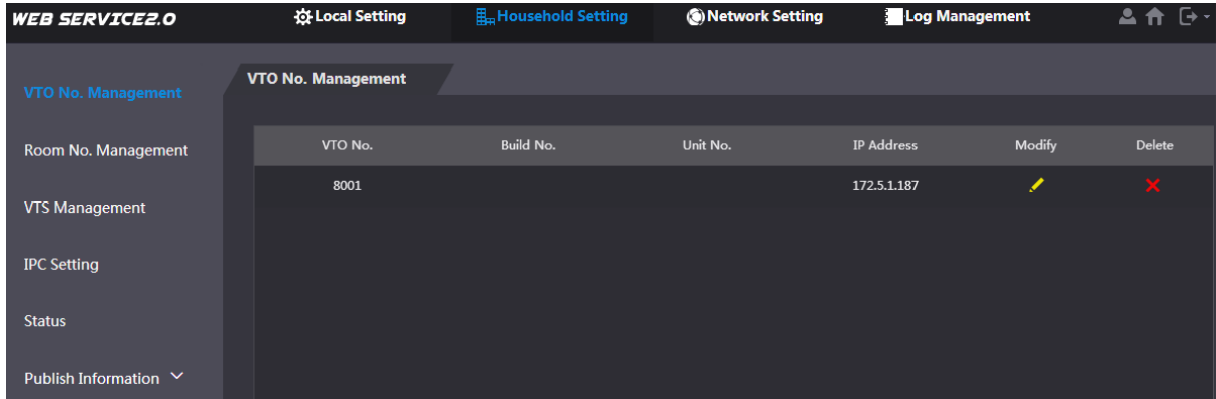

Figure 2-9

Step 10 Click “Add”, set outdoor station parameters by reference to Table 2-2 and click “OK”.

Repeat this step to add other outdoor stations in the group.

| Parameter | Description |
|-------------------|---|
| VTO No. | VTO number. |
| Register Password | Signaling interactive use in SIP system. Adopt default value. |
| Build No. | Number of the building where VTO is located. |
| Unit No. | Number of the unit where VTO is located. |
| IP Address | IP address of VTO. |
| Username/Password | Username and password to login WEB interface of this VTO. |

Table 2-2

Step 11 (Optional) Select “Household Setting > Room No. Management”.

The system displays “Room No. Management” interface, as shown in Figure 2-10.

 **NOTE**

When there are master VTH and extension, both shall be added.

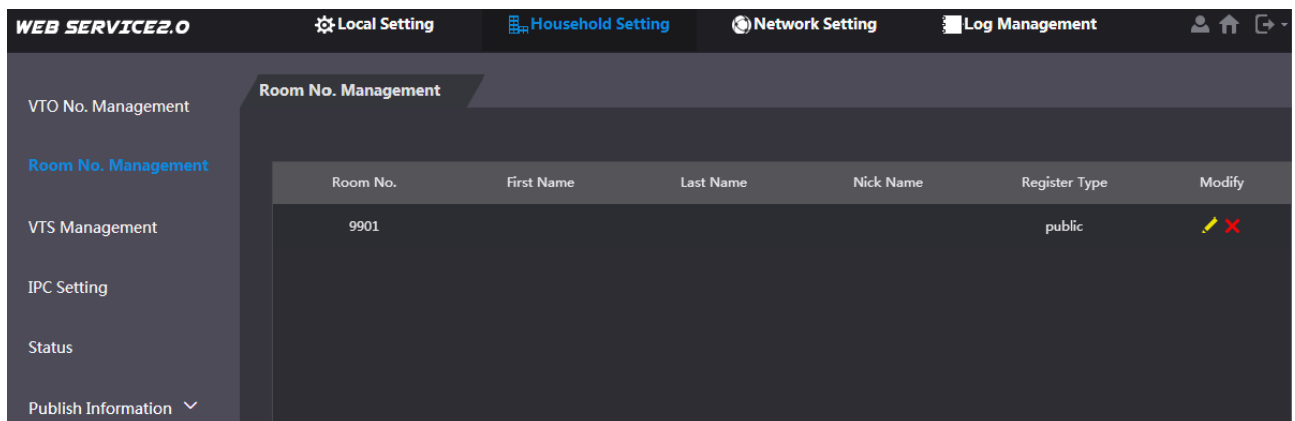

Figure 2-10

Step 12 Click “Add”, set VTH parameters by reference to Table 2-3 and click “OK”. Repeat these steps to add other VTH in the group.

| Parameter | Description |
|-------------|---|
| Family Name | Set VTH username and nickname, in order to distinguish. |
| First Name | |
| Nick Name | |

| Parameter | Description |
|-------------------|---|
| Room No. | Set VTH room number.  NOTE <ul style="list-style-type: none"> VTH room number consists of 1~6 numbers, letters, or their combinations. It shall be consistent with room number configured at VTH. When there are master VTH and extensions, to realize group call function, master VTH short no. shall end with "#0", whereas extension VTH short no. shall end with #1, #2 and #3. For example, if master VTH is 101#0, extensions will be 101#1, 101#2... |
| Register Type | Signaling interactive use in SIP system. Adopt default value. |
| Register Password | |

Table 2-3

2.2.2 VTH Settings

2.2.2.1 Initialization

For the first time, please initialize the password and bind Email. Password is used to enter project setting interface, while Email is used to retrieve your password when you forget it.

Step 1 Power on the device.

The system displays "Welcome" and enters "Initialization" interface, as shown in Figure 2-11.

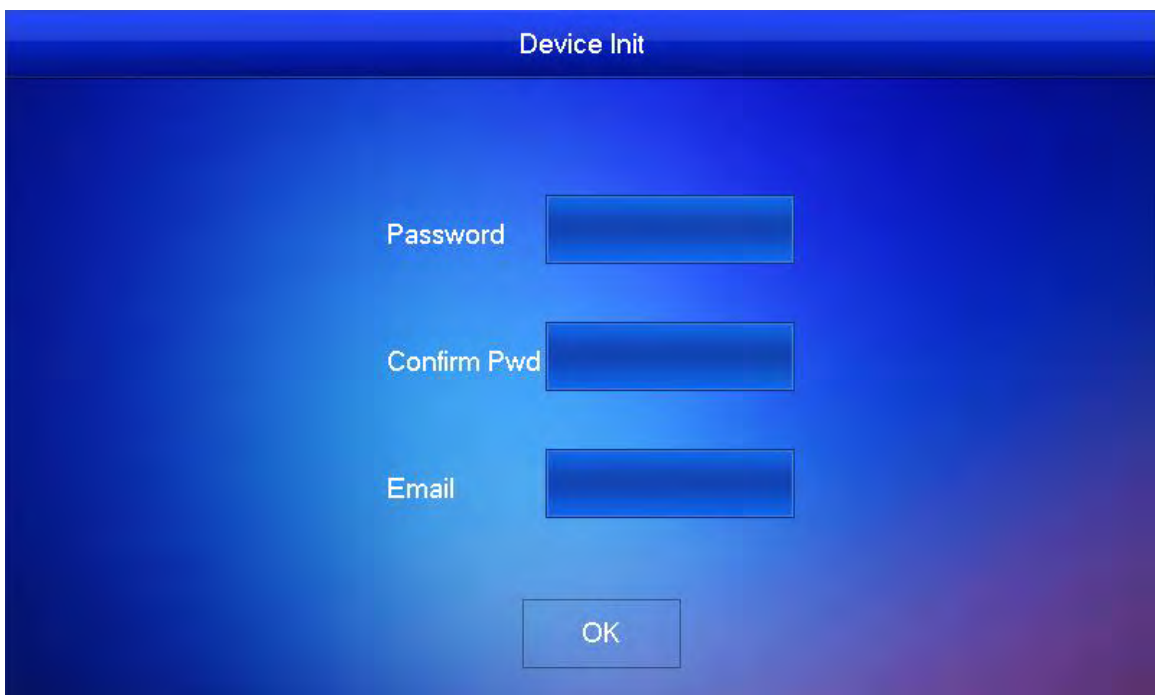

The screenshot shows a blue-themed interface titled "Device Init". It contains three input fields: "Password", "Confirm Pwd", and "Email". Each field is represented by a blue rectangular box. Below these fields is a single "OK" button, also in a blue box. The background is a gradient of blue and purple.

Figure 2-11

Step 2 Enter “Password”, “Confirm Pwd” and “Email”. Press [OK].

Step 3 Press [Setting] for more than 6 seconds, enter the password set during initialization, and click [OK].

Step 4 Click [Network].

The system displays “Network” interface, as shown in Figure 2-12 or Figure 2-13.

 **NOTE**

IP addresses of VTH and VTO shall be in the same network segment. Otherwise, VTH will fail to obtain VTO info after configuration.

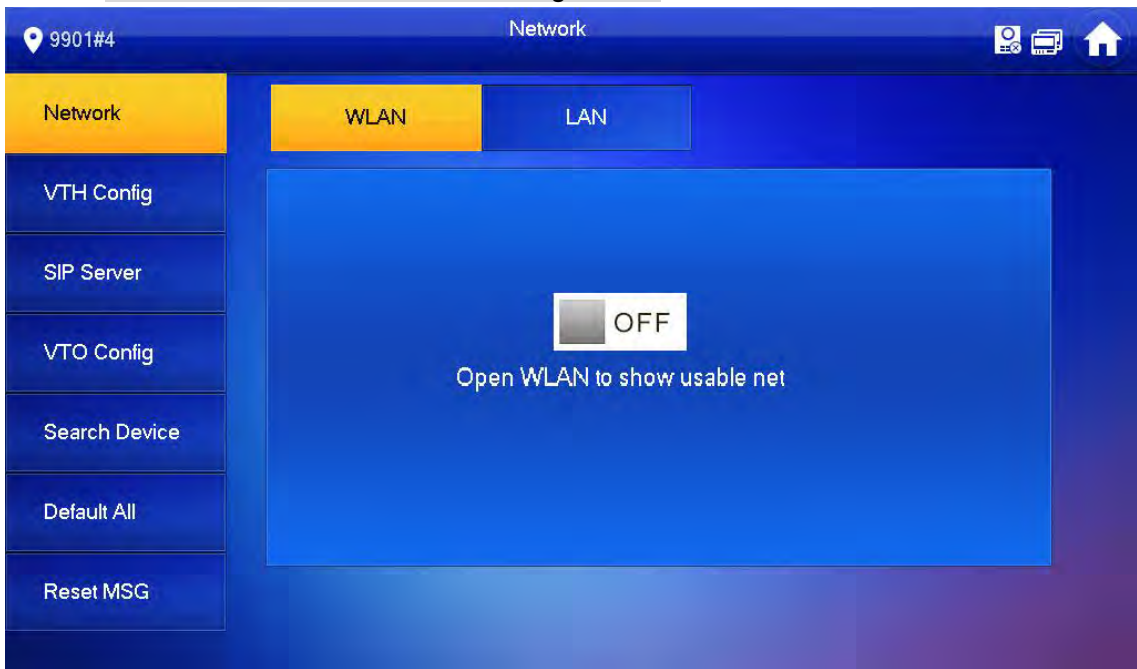

Figure 2-12



Figure 2-13

- LAN

Enter “Local IP”, “Subnet Mask” and “Gateway”, press [OK]. Or press OFF to enable DHCP function and obtain IP info automatically.

 NOTE

If the device has WLAN function, please click “WLAN” tab to set it.

- WLAN

1) Press OFF to enable Wi-Fi function.

The system displays available Wi-Fi list, as shown in Figure 2-14.



Figure 2-14

2) Connect Wi-Fi.

The system has 2 access ways as follows.

- ◇ At “WLAN” interface, select Wi-Fi, click “Wireless IP” tab to enter “Local IP”, “Subnet Mask” and “Gateway”, and press [OK].
- ◇ At “WLAN” interface, select Wi-Fi, click “Wireless IP” tab, press OFF to enable DHCP function and obtain IP info automatically.

 NOTE

To obtain IP info with DHCP function, use a router with DHCP function.

Step 5 Press [VTH Config].

The system displays “VTH Config” interface, as shown in Figure 2-15.



Figure 2-15

- Be used as a master VTH.

Enter “Room No.” (such as 9901 or 101#0) and press “OK” to save.

NOTE

- “Room no.” shall be the same with “VTH Short No.”, which is set when adding VTH at WEB interface. Otherwise, it will fail to connect VTO.
- In case of extension VTH, room no. shall end with #0. Otherwise, it will fail to connect VTO.
- Be used as an extension VTH.
 - 1) Press [Master] and switch to “Extension”.
 - 2) Enter “Room No.” (such as 101#1) and “Master IP” (IP address of master VTH). “Master Name” and “Master Pwd” are the user name and password of master VTH. Default user name is admin, and the password is the one set during device initialization.
 - 3) Press [OK] to save settings.

Step 6 Press [SIP Server].

The system displays “SIP Server” interface, as shown in Figure 2-16.

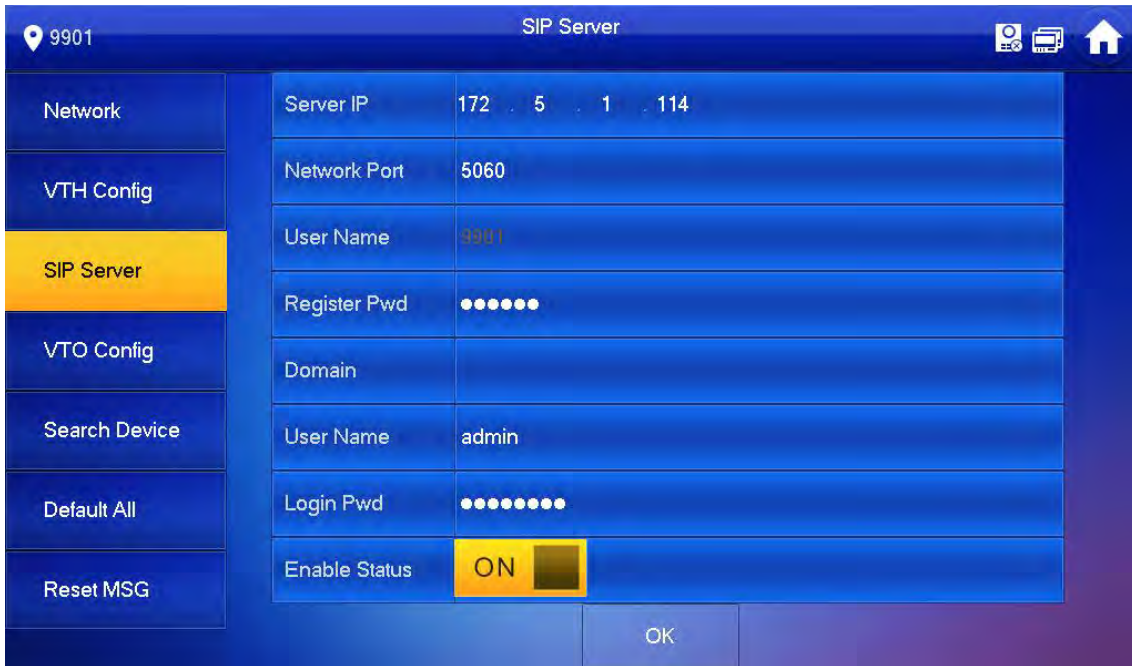

Figure 2-16

1) Set parameters of SIP server by reference to Table 2-4.

| Parameter | Description |
|--------------|--|
| Server IP | <ul style="list-style-type: none"> When the platform works as SIP server, server IP is IP address of the platform. When VTO works as SIP server, server IP is IP address of the VTO. |
| Network Port | <ul style="list-style-type: none"> When the platform works as SIP server, network port is 5080. When VTO works as SIP server, network port is 5060. |
| User Name | Use default value. |
| Register Pwd | |
| Domain | Registration domain of SIP server, which can be null. When VTO works as SIP server, registration domain of SIP server shall be VDP. |
| User Name | User name and password to login SIP server. |
| Login Pwd | |

Table 2-4

2) Set "Enable Status" to be ON OFF.

Enable SIP server function.

3) Press [OK] to save settings.

Step 7 Press [VTO Config].

The system displays "VTO Config" interface, as shown in Figure 2-17.

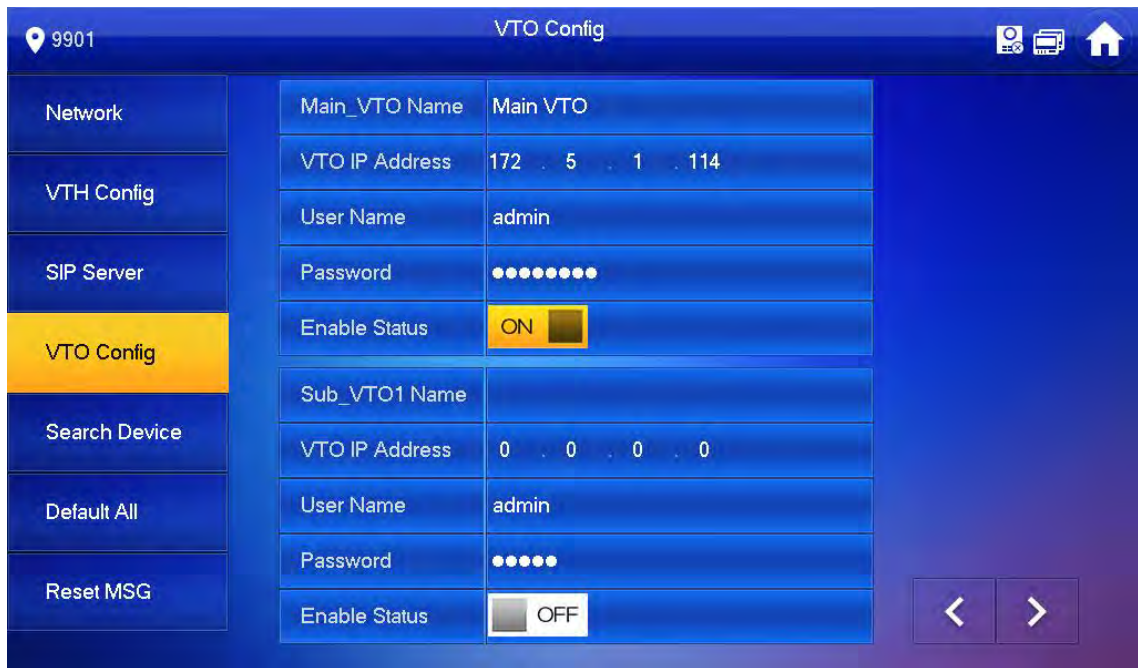



Figure 2-17

Step 8 Add VTO or fence station.



- Add main VTO.
 - 1) Enter “Main VTO Name”, “VTO IP Address”, “User Name” and “Password”.
 - 2) Switch the “Enable Status” to be .

 NOTE

“User Name” and “Password” shall be consistent with WEB login user name and password of VTO. Otherwise, it will fail to connect.

- Add sub VTO or fence station.
 - 1) Enter “Sub VTO/Fence Station Name”, “Sub VTO/Fence Station IP address”, “User Name” and “Password”.
 - 2) Switch the “Enable Status” to be .

 NOTE

Press  /  to turn page and add more sub VTO/fence stations.

2.3 Debugging Verification

2.3.1 VTO Calls VTH

Dial VTH room no. (such as 101) at VTO, and thus call VTH. VTH pops up monitoring image and operating keys, as shown in Figure 2-18. It represents successful debugging.

 NOTE

The following figure means that SD card has been inserted into VTH. If SD card is not inserted, recording and snapshot icons are gray.



Figure 2-18

2.3.2 VTH Monitors VTO

VTH is able to monitor VTO, fence station or IPC. Take “VTO” for example.

Select “Monitor > Door”, as shown in Figure 2-19. Select the VTO to enter monitoring image, as shown in Figure 2-20.

 NOTE

The following figure means that SD card has been inserted into VTH. If SD card is not inserted, recording and snapshot icons are gray.

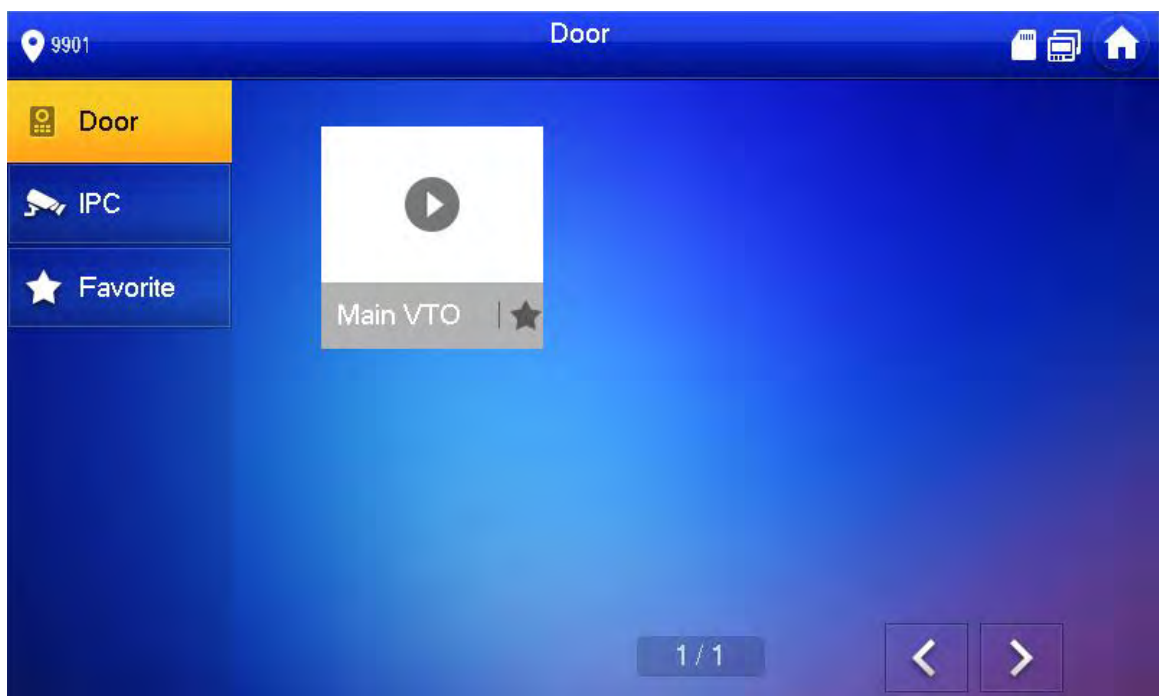

Figure 2-19

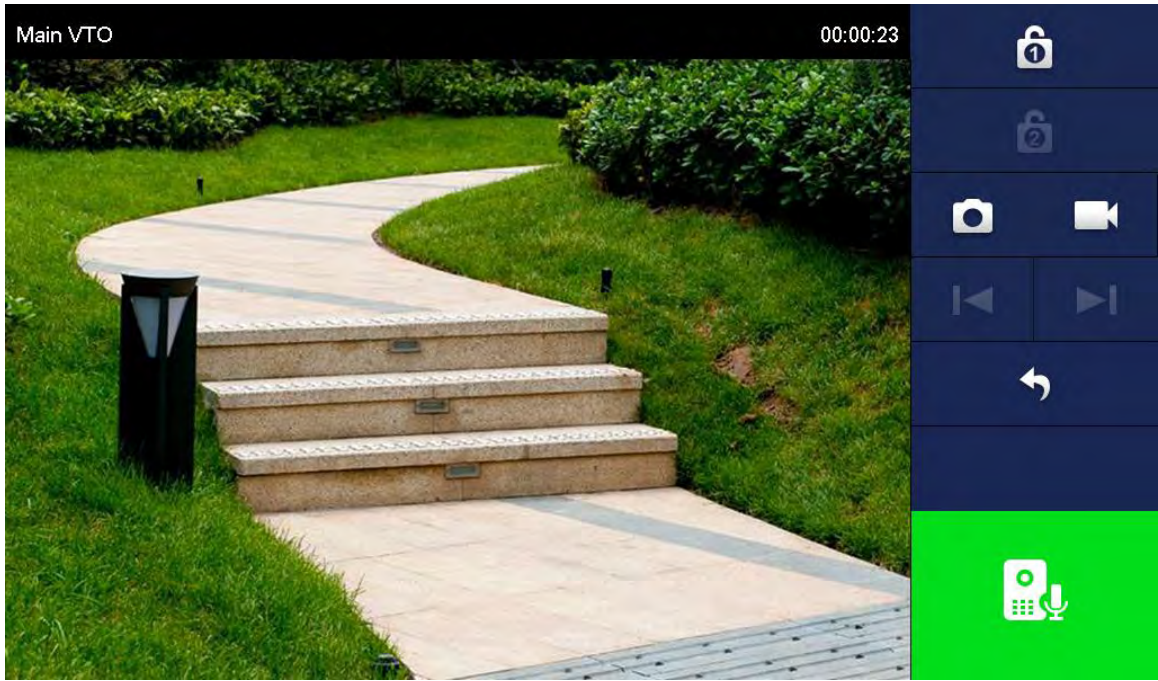

Figure 2-20