

RF MEASUREMENT REPORT

FCC ID: SVC-M66
Applicant: Lenbrook Industries Limited
Product: M66 Streaming DAC Preamplifier
Model No.: M66
Brand Name: NAD
FCC Classification: Unlicensed National Information Infrastructure (NII)
FCC Rule Part(s): Part 15 Subpart E (Section 15.407)
Result: Complies
Received Date: 2024-04-28
Test Date: 2024-05-08 ~ 2024-06-13

Reviewed By:

Ada Zhang

Approved By:

Robin Wu



The test results relate only to the samples tested.

This equipment has been shown to be capable of compliance with the applicable technical standards as indicated in the measurement report and was tested in accordance with the measurement procedures specified in KDB789033. Test results reported herein relate only to the item(s) tested.

The test report shall not be reproduced except in full without the written approval of MRT Technology (Suzhou) Co., Ltd.

Revision History

Report No.	Version	Description	Issue Date	Note
2401RSU027-U4	V01	Initial Report	2024-07-26	Valid

CONTENTS

Description	Page
1. General Information	6
1.1. Applicant	6
1.2. Manufacturer.....	6
1.3. Testing Facility	6
1.4. Product Information	7
1.5. Radio Specification under Test	7
1.6. Working Frequencies.....	8
1.7. Antenna Details	8
2. Test Configuration	9
2.1. Test Mode	9
2.2. Test System Connection Diagram	9
2.3. Test Software	10
2.4. Applied Standards	10
2.5. Test Environment Condition.....	10
3. Antenna Requirements	11
4. Measuring Instrument	12
5. Decision Rules and Measurement Uncertainty	13
5.1. Decision Rules.....	13
5.2. Measurement Uncertainty	13
6. Test Result.....	14
6.1. Summary	14
6.2. 26dB & 99% Bandwidth Measurement.....	15
6.2.1. Test Limit.....	15
6.2.2. Test Procedure	15
6.2.3. Test Setting	15
6.2.4. Test Setup.....	16
6.2.5. Test Result	16
6.3. 6dB Bandwidth Measurement	17
6.3.1. Test Limit.....	17
6.3.2. Test Procedure	17
6.3.3. Test Setting	17
6.3.4. Test Setup.....	17
6.3.5. Test Result	17
6.4. Output Power Measurement.....	18
6.4.1. Test Limit.....	18

6.4.2.	Test Procedure	18
6.4.3.	Test Setting	18
6.4.4.	Test Setup	18
6.4.5.	Test Result	18
6.5.	Transmit Power Control Measurement	19
6.5.1.	Test Limit	19
6.5.2.	Test Procedure	19
6.5.3.	Test Setting	19
6.5.4.	Test Setup	19
6.5.5.	Test Result	19
6.6.	Power Spectral Density Measurement	20
6.6.1.	Test Limit	20
6.6.2.	Test Procedure	20
6.6.3.	Test Setting	20
6.6.4.	Test Setup	21
6.6.5.	Test Result	21
6.7.	Frequency Stability Measurement	22
6.7.1.	Test Limit	22
6.7.2.	Test Procedure	22
6.7.3.	Test Setup	22
6.7.4.	Test Result	23
6.8.	Radiated Spurious Emission Measurement	24
6.8.1.	Test Limit	24
6.8.2.	Test Procedure	24
6.8.3.	Test Setting	24
6.8.4.	Test Setup	26
6.8.5.	Test Result	27
6.9.	Radiated Restricted Band Edge Measurement	28
6.9.1.	Test Limit	28
6.9.2.	Test Procedure	30
6.9.3.	Test Setting	30
6.9.4.	Test Setup	31
6.9.5.	Test Result	31
6.10.	AC Conducted Emissions Measurement	32
6.10.1.	Test Limit	32
6.10.2.	Test Setup	32
6.10.3.	Test Result	32
Appendix A – Test Result		33
A.1	Duty Cycle Test Result	33

A.2	26dB & 99% Bandwidth Test Result	34
A.3	6dB Bandwidth Test Result	43
A.4	Output Power Test Result	47
A.5	Power Spectral Density Test Result	49
A.6	Frequency Stability Test Result.....	59
A.7	Radiated Spurious Emission Test Result	60
A.8	Radiated Restricted Band Edge Test Result.....	104
A.9	AC Conducted Emissions Test Result	174
Appendix B – Test Setup Photograph		178
Appendix C – EUT Photograph		179

1.4. Product Information

Product Name	M66 Streaming DAC Preamplifier
Model No.	M66
Brand Name	NAD
Serial No.	H237M6601014
Bluetooth Specification	Bluetooth-BR/EDR
Wi-Fi Specification	802.11a/b/g/n/ac
Antenna Information	Refer to Section 1.7
Power Type	100-240V ~ 50/60Hz
Operating Temperature	0 ~ 40°C

Note: The information of EUT was provided by the manufacturer, and the accuracy of the information shall be the responsibility of the manufacturer.

1.5. Radio Specification under Test

Frequency Range	802.11a/n-HT20/ac-VHT20: 5180~5240MHz, 5260~5320MHz, 5500~5720MHz, 5745~5825MHz 802.11n-HT40/ac-VHT40: 5190~5230MHz, 5270~5310MHz, 5510~5710MHz, 5755~5795MHz 802.11ac-VHT80: 5210MHz, 5290MHz, 5530MHz, 5610 MHz, 5690MHz, 5775MHz
Type of Modulation	802.11a/n/ac: OFDM
Data Rate	802.11a: 6/9/12/18/24/36/48/54Mbps 802.11n: up to 150Mbps 802.11ac: up to 433.3Mbps

1.6. Working Frequencies

802.11a/n-HT20/ac-VHT20

Channel	Frequency	Channel	Frequency	Channel	Frequency
36	5180 MHz	40	5200 MHz	44	5220 MHz
48	5240 MHz	52	5260 MHz	56	5280 MHz
60	5300 MHz	64	5320 MHz	100	5500 MHz
104	5520 MHz	108	5540 MHz	112	5560 MHz
116	5580 MHz	120	5600 MHz	124	5620 MHz
128	5640 MHz	132	5660 MHz	136	5680 MHz
140	5700 MHz	144	5720 MHz	149	5745 MHz
153	5765 MHz	157	5785 MHz	161	5805 MHz
165	5825 MHz	--	--	--	--

802.11n-HT40/ac-VHT40

Channel	Frequency	Channel	Frequency	Channel	Frequency
38	5190 MHz	46	5230 MHz	54	5270 MHz
62	5310 MHz	102	5510 MHz	110	5550MHz
118	5590 MHz	126	5630 MHz	134	5670 MHz
142	5710 MHz	151	5755 MHz	159	5795 MHz

802.11ac-VHT80

Channel	Frequency	Channel	Frequency	Channel	Frequency
42	5210 MHz	58	5290 MHz	106	5530 MHz
122	5610 MHz	138	5690 MHz	155	5775 MHz

1.7. Antenna Details

Antenna Type	Frequency Band (MHz)	Antenna Gain (dBi)
Dipole Antenna	2400 ~ 2483.5	1.97
	5150 ~ 5850	2.74

Note: The antenna gain is from antenna data sheet provided by the manufacturer.

2. Test Configuration

2.1. Test Mode

Mode 1: Transmit by 802.11a (6Mbps)
Mode 2: Transmit by 802.11ac-VHT20 (MCS0)
Mode 3: Transmit by 802.11ac-VHT40 (MCS0)
Mode 4: Transmit by 802.11ac-VHT80 (MCS0)
Note 1: All modes of operation and data rates were investigated, so all RF test requirements shall be executed at the worst data rate.
Note 2: 802.11n and 802.11ac have same modulation type and same power value, so we only show 802.11ac test data in report.

2.2. Test System Connection Diagram

The device was tested per the guidance ANSI C63.10: 2013 was used to reference the appropriate EUT setup for radiated emissions testing and AC line conducted testing.

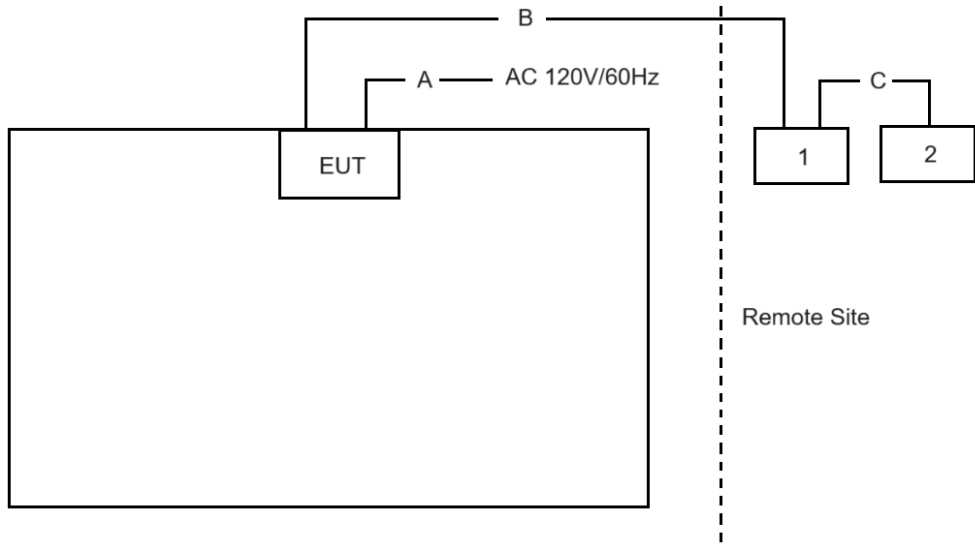
Connection Diagram			
			
Cable Type		Cable Description	Length
A	Power Cable	Non-Shielded	1.8m
B	LAN Cable	Non shielded, Cat.5e	> 10m
C	LAN Cable	Non shielded, Cat.5e	1.0m
Product		Manufacturer	Model No.
1	Router	TP-LINK	TL-WDR5620
2	Notebook	Lenovo	E430C

2.3. Test Software

The test utility software used during testing was “IPOP” and the commands were provided by the manufacturer.

2.4. Applied Standards

According to the specifications of the manufacturer, the EUT must comply with the requirements of the following standards:

- FCC Part 15.407
- KDB 789033 D02v02r01
- ANSI C63.10-2013

2.5. Test Environment Condition

Ambient Temperature	15 ~ 35°C
Relative Humidity	20 ~ 75%RH

3. Antenna Requirements

Excerpt from §15.203 of the FCC Rules/Regulations:

“An intentional radiator antenna shall be designed to ensure that no antenna other than that furnished by the responsible party can be used with the device. The use of a permanently attached antenna or of an antenna that uses a unique coupling to the intentional radiator shall be considered sufficient to comply with the provisions of this section.”

- The antenna that uses a **unique coupling**.

Conclusion:

The unit complies with the requirement of §15.203.

4. Measuring Instrument

Instrument	Manufacturer	Model No.	Asset No.	Cali. Interval	Cali. Due Date	Test Site
EMI Test Receiver	R&S	ESR7	MRTSUE06001	1 year	2024-12-17	WZ-AC1
Signal Analyzer	Keysight	N9010B	MRTSUE06607	1 year	2024-10-23	WZ-AC1
Active Loop Antenna	Schwarzbeck	FMZB 1519-60 D	MRTSUE07076	1 year	2024-12-04	WZ-AC1
TRILOG Antenna	Schwarzbeck	VULB 9168	MRTSUE06172	1 year	2024-06-09	WZ-AC1
TRILOG Antenna	Schwarzbeck	VULB 9168	MRTSUE06172	1 year	2025-05-15	WZ-AC1
Horn Antenna	Schwarzbeck	BBHA 9120D	MRTSUE06023	1 year	2024-08-09	WZ-AC1
Horn Antenna	Schwarzbeck	BBHA 9170	MRTSUE06024	1 year	2024-10-11	WZ-AC1
Preamplifier	Agilent	83017A	MRTSUE06076	1 year	2024-11-09	WZ-AC1
Preamplifier	EMCI	EMC184045SE	MRTSUE06640	1 year	2025-01-11	WZ-AC1
Thermohygrometer	testo	608-H1	MRTSUE11039	1 year	2024-10-25	WZ-AC1
Anechoic Chamber	TDK	WZ-AC1	MRTSUE06212	1 year	2025-04-19	WZ-AC1
Signal Analyzer	Keysight	N9010B	MRTSUE07027	1 year	2024-10-23	WZ-SR4
USB Power Sensor	Keysight	U2021XA	MRTSUE06446	1 year	2024-05-23	WZ-SR4
USB Power Sensor	Keysight	U2021XA	MRTSUE06446	1 year	2025-05-08	WZ-SR4
Attenuator	MVE	MVE2365	MRTSUE07071	1 year	2024-11-27	WZ-SR4
Thermohygrometer	testo	608-H1	MRTSUE11256	1 year	2024-10-19	WZ-SR4
Shielding Room	HUAMING	WZ-SR4	MRTSUE06441	N/A	N/A	WZ-SR4
Temperature Chamber	BAOYT	BYH-150CL	MRTSUE06051	1 year	2024-09-27	WZ-TR3
Signal Analyzer	Keysight	N9010B	MRTSUE07027	1 year	2024-10-23	WZ-TR3
Thermohygrometer	testo	608-H1	MRTSUE11268	1 year	2024-12-14	WZ-TR3
Two-Line V-Network	R&S	ENV216	MRTSUE06002	1 year	2024-05-23	WZ-SR2
Two-Line V-Network	R&S	ENV216	MRTSUE06002	1 year	2025-05-08	WZ-SR2
EMI Test Receiver	R&S	ESR3	MRTSUE06909	1 year	2024-09-27	WZ-SR2
Thermohygrometer	testo	608-H1	MRTSUE06404	1 year	2024-05-31	WZ-SR2
Thermohygrometer	testo	608-H1	MRTSUE06404	1 year	2025-05-12	WZ-SR2
Shielding Room	MIX-BEP	WZ-SR2	MRTSUE06215	5 years	2026-12-20	WZ-SR2

Software	Version	Function
EMI V3	V 3.0.0	EMI Test Software
Controller_MF 7802	2.03C	RE Antenna & Turntable
BenchVue Power Meter	2018.1	Power

5. Decision Rules and Measurement Uncertainty

5.1. Decision Rules

The Decision Rule is based on Simple Acceptance in accordance with ISO Guide 98-4: 2012 Clause 8.2. (Measurement uncertainty is not taken into account when stating conformity with a specified requirement.)

5.2. Measurement Uncertainty

Where relevant, the following test uncertainty levels have been estimated for tests performed on the EUT as specified in CISPR 16-4-2. This uncertainty represents an expanded uncertainty expressed at approximately the 95% confidence level using a coverage factor of $k = 2$.

AC Conducted Emission Measurement
The maximum measurement uncertainty is evaluated as: 9kHz~150kHz: 3.58dB 150kHz~30MHz: 3.20dB
Radiated Emission Measurement
The maximum measurement uncertainty is evaluated as: Coaxial: 9kHz~30MHz: 2.61dB Coplanar: 9kHz~30MHz: 2.62dB Horizontal: 30MHz~200MHz: 3.79dB 200MHz~1GHz: 3.91dB 1GHz~40GHz: 4.99dB Vertical: 30MHz~200MHz: 4.06dB 200MHz~1GHz: 5.21dB 1GHz~40GHz: 4.90dB
Spurious Emissions, Conducted
Measuring Uncertainty for a Level of Confidence of 95% ($U=2Uc(y)$): 2.2dB
Output Power
Measuring Uncertainty for a Level of Confidence of 95% ($U=2Uc(y)$): 1.4dB
Power Spectrum Density
Measuring Uncertainty for a Level of Confidence of 95% ($U=2Uc(y)$): 2.2dB
Occupied Bandwidth
Measuring Uncertainty for a Level of Confidence of 95% ($U=2Uc(y)$): 2.7%

6. Test Result

6.1. Summary

FCC Section(s)	Test Description	Test Condition	Verdict
15.407(a)	26dB Bandwidth	Conducted	Pass
15.407(e)	6dB Bandwidth		Pass
15.407(a)(1)(iv), (2), (3)(i)	Maximum Conducted Output Power		Pass
15.407(h)(1)	Transmit Power Control		N/A
15.407(g)	Frequency Stability		Pass
15.407(a)(1)(iv), (2), (3)(i)	Peak Power Spectral Density		Pass
15.407(h)(2)	Dynamic Frequency Selection (DFS)		Pass ^{Note 2}
15.407(b)(1), (2), (3), (4)(i)	Undesirable Emissions	Radiated	Pass
15.205, 15.209 15.407(b)(8), (9), (10)	General Field Strength Limits (Restricted Bands and Radiated Emission Limits)		Pass
15.207	AC Conducted Emissions 150kHz - 30MHz	Line Conducted	Pass

Notes:

- The analyzer plots shown in this section were all taken with a correction table loaded into the analyzer. The correction table was used to account for the losses of the cables and attenuators used as part of the system to connect the EUT to the analyzer at all frequencies of interest.
- DFS report refer to 2401RSU027-U5.
- "N/A" means that this item is not applicable, the EUT doesn't support TPC mechanism.

6.2. 26dB & 99% Bandwidth Measurement

6.2.1. Test Limit

N/A

6.2.2. Test Procedure

KDB 789033 D02v02r01- Section II)C)1) (26dB Bandwidth)

KDB 789033 D02v02r01- Section II)D) (99% Bandwidth)

6.2.3. Test Setting

26dB Bandwidth

1. The analyzers' automatic bandwidth measurement capability was used to perform the 26dB bandwidth
2. RBW = approximately 1% of the emission bandwidth.
3. VBW > RBW
4. Detector = Peak.
5. Trace mode = max hold.
6. Measure the maximum width of the emission that is 26 dB down from the maximum of the emission.
Compare this with the RBW setting of the analyzer. Readjust RBW and repeat measurement as needed until the RBW/EBW ratio is approximately 1%.

99% Bandwidth

1. Set center frequency to the nominal EUT channel center frequency.
2. RBW = 1% to 5% of the OBW
3. VBW $\geq 3 \times$ RBW
4. Span = 1.5 times to 5 times the OBW
5. Detector = peak
6. Trace mode = max hold
7. Allow the trace to stabilize
8. Use the 99% power bandwidth function of the instrument.

6.2.4. Test Setup

Spectrum Analyzer

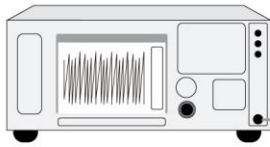

DC Block
&
Attenuator



6.2.5. Test Result

Refer to Appendix A.2.

6.3. 6dB Bandwidth Measurement

6.3.1. Test Limit

The minimum 6dB bandwidth shall be at least 500 kHz.

6.3.2. Test Procedure

KDB 789033 D02v02r01- Section II)C)2)

6.3.3. Test Setting

1. Set center frequency to the nominal EUT channel center frequency.
2. RBW = 100 kHz.
3. VBW $\geq 3 \times$ RBW.
4. Detector = Peak.
5. Trace mode = max hold.
6. Sweep = auto couple.
7. Allow the trace to stabilize.
8. Measure the maximum width of the emission that is constrained by the frequencies associated with the two outermost amplitude points (upper and lower frequencies) that are attenuated by 6 dB relative to the maximum level measured in the fundamental emission.

6.3.4. Test Setup

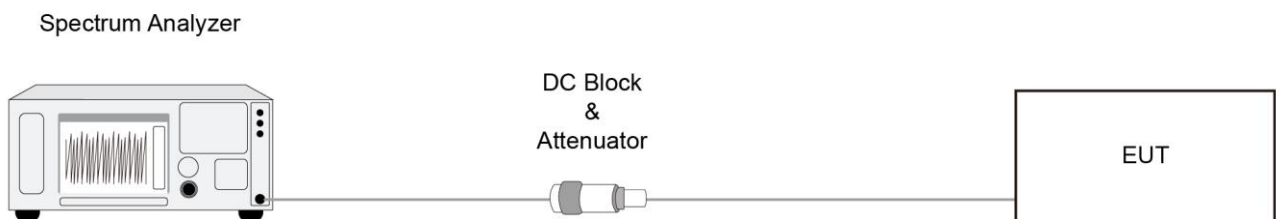

6.3.5. Test Result

Refer to Appendix A.3.

6.4. Output Power Measurement

6.4.1. Test Limit

For client devices in the 5.15-5.25 GHz band, the maximum conducted output power over the frequency band of operation shall not exceed 250 mW provided the maximum antenna gain does not exceed 6 dBi.

For the 5.25-5.35 GHz and 5.47-5.725 GHz bands, the maximum conducted output power over the frequency bands of operation shall not exceed the lesser of 250 mW or $11 \text{ dBm} + 10 \log B$, where B is the 26 dB emission bandwidth in megahertz.

For the band 5.725-5.85 GHz, the maximum conducted output power over the frequency band of operation shall not exceed 1 W (30dBm).

If transmitting antennas of directional gain greater than 6dBi are used, the maximum conducted output power shall be reduced by the amount in dB that the directional gain of the antenna exceeds 6dBi.

6.4.2. Test Procedure

KDB 789033D02v02r01- Section II)E)3)b) Method PM-G

6.4.3. Test Setting

Average Power Measurement

Average power measurements were performed only when the EUT was transmitting at its maximum power control level using a broadband power meter with a pulse sensor. The power meter implemented triggering and gating capabilities which were set up such that power measurements were recorded only during the ON time of the transmitter.

6.4.4. Test Setup

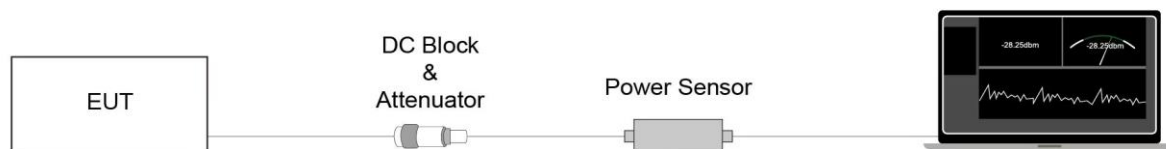

6.4.5. Test Result

Refer to Appendix A.4.

6.5. Transmit Power Control Measurement

6.5.1. Test Limit

The U-NII device is required to have the capability to operate at least 6 dB below the mean EIRP value of 30 dBm. A TPC mechanism is not required for systems with an EIRP of less than 500 mW.

6.5.2. Test Procedure

KDB 789033 D02v02r01- Section II)E)3)b) Method PM-G

6.5.3. Test Setting

Average power measurements were performed only when the EUT was transmitting at its maximum power control level using a broadband power meter with a pulse sensor. The power meter implemented triggering and gating capabilities which were set up such that power measurements were recorded only during the ON time of the transmitter. The trace was averaged over 100 traces to obtain the final measured average power.

6.5.4. Test Setup

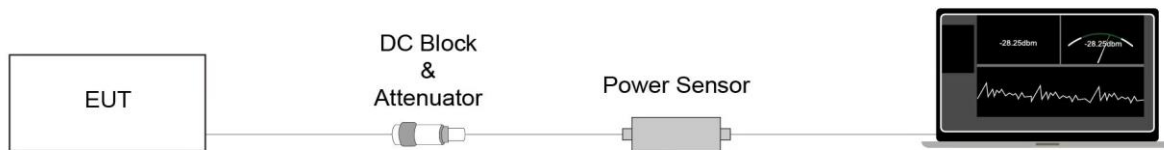

6.5.5. Test Result

Device doesn't support TPC mechanism, so this item is not applicable.

6.6. Power Spectral Density Measurement

6.6.1. Test Limit

For client devices in the 5.15-5.25 GHz band, the maximum power spectral density shall not exceed 11 dBm in any 1 megahertz band.

For the 5.25-5.35 GHz and 5.47-5.725 GHz bands, the maximum power spectral density shall not exceed 11 dBm in any 1 megahertz band.

For the band 5.725-5.85 GHz, the maximum power spectral density shall not exceed 30 dBm in any 500 kHz band.

If transmitting antennas of directional gain greater than 6dBi are used, the peak power spectral density shall be reduced by the amount in dB that the directional gain of the antenna exceeds 6dBi.

6.6.2. Test Procedure

KDB 789033 D02v02r01-Section II)F)

6.6.3. Test Setting

1. Analyzer was set to the center frequency of the UNII channel under investigation
2. Span was set to encompass the entire 26dB EBW of the signal.
3. RBW = 1MHz (510kHz, if measurement bandwidth of Maximum PSD is specified in 500 kHz)
4. VBW = 3 × RBW
5. Number of sweep points $\geq 2 \times (\text{span} / \text{RBW})$
6. Detector = power averaging (Average)
7. Sweep time = auto
8. Trigger = free run
9. Trace average at least 100 traces in power averaging (rms) mode; however, the number of traces to be averaged shall be increased above 100 as needed to ensure that the average accurately represents the true average over the on and off periods of the transmitter.
10. Use the peak search function on the instrument to find the peak of the spectrum and record its value.
11. Add $10 \cdot \log(1/x)$, where x is the duty cycle, to the measured power in order to compute the average power during the actual transmission times (because the measurement represents an average over both the on and off times of the transmission). For example, add $10 \cdot \log(1/0.25) = 6$ dB if the duty cycle is 25 percent.

6.6.4. Test Setup

Spectrum Analyzer

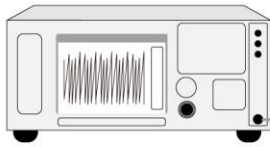

DC Block
&
Attenuator



6.6.5. Test Result

Refer to Appendix A.5.

6.7. Frequency Stability Measurement

6.7.1. Test Limit

Manufactures of U-NII devices are responsible for ensuring frequency stability such that an emission is maintained within the band of operation under all conditions of normal operation as specified in the user’s manual.

6.7.2. Test Procedure

Frequency Stability Under Temperature Variations:

The equipment under test was connected to an external AC or DC power supply and input rated voltage. RF output was connected to a frequency counter or spectrum analyzer via feed through attenuators. The EUT was placed inside the temperature chamber. Set the spectrum analyzer RBW low enough to obtain the desired frequency resolution and measure EUT 20°C operating frequency as reference frequency. Turn EUT off and set the chamber temperature to highest. After the temperature stabilized for approximately 30 minutes recorded the frequency. Repeat step measure with 10°C decreased per stage until the lowest temperature reached.

Frequency Stability Under Voltage Variations:

Set chamber temperature to 20°C. Use a variable AC power supply / DC power source to power the EUT and set the voltage to rated voltage. Set the spectrum analyzer RBW low enough to obtain the desired frequency resolution and recorded the frequency.

Reduce the input voltage to specify extreme voltage variation ($\pm 15\%$) and endpoint, record the maximum frequency change.

6.7.3. Test Setup

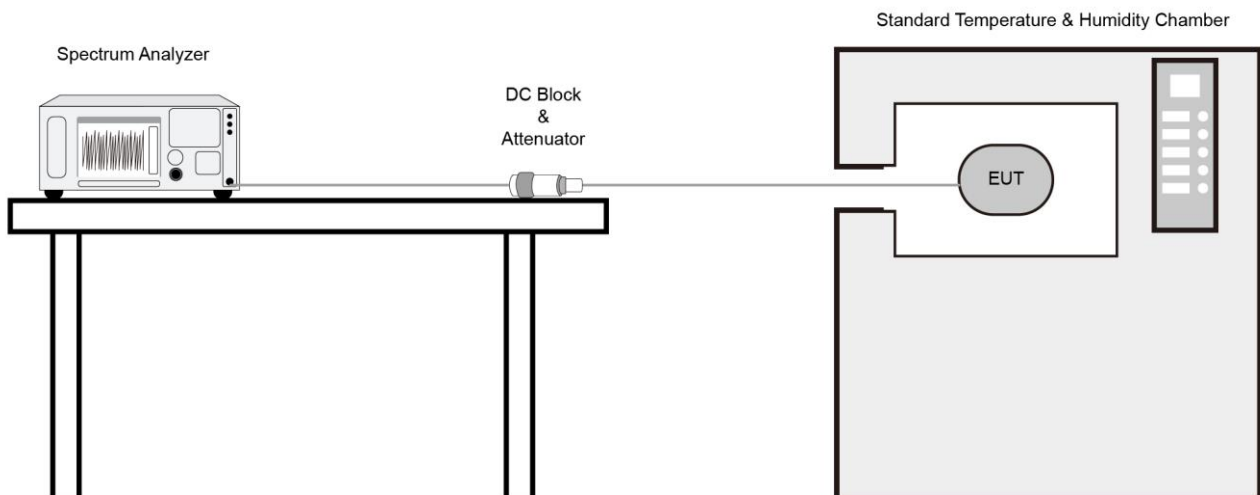

6.7.4. Test Result

Refer to Appendix A.6.

6.8. Radiated Spurious Emission Measurement

6.8.1. Test Limit

All out of band emissions appearing in a restricted band as specified in Section 15.205 of the Title 47 CFR must not exceed the limits shown in Table per Section 15.209.

FCC Part 15 Subpart C Paragraph 15.209		
Frequency [MHz]	Field Strength [$\mu\text{V/m}$]	Measured Distance [Meters]
0.009 - 0.490	2400/F (kHz)	300
0.490 - 1.705	24000/F (kHz)	30
1.705 - 30	30	30
30 - 88	100	3
88 - 216	150	3
216 - 960	200	3
Above 960	500	3

6.8.2. Test Procedure

KDB 789033 D02v02r01- Section II)G)

6.8.3. Test Setting

Table 1 - RBW as a function of frequency

Frequency	RBW
9 ~ 150 kHz	200 ~ 300 Hz
0.15 ~ 30 MHz	9 ~ 10 kHz
30 ~ 1000 MHz	100 ~ 120 kHz
> 1000MHz	1MHz

Quasi-Peak Measurements below 1GHz

1. Analyzer center frequency was set to the frequency of the radiated spurious emission of interest
2. Span was set greater than 1MHz
3. RBW = as specified in Table 1
4. Detector = CISPR quasi-peak
5. Sweep time = auto couple
6. Trace was allowed to stabilize

Peak Measurements above 1GHz

1. Analyzer center frequency was set to the frequency of the radiated spurious emission of interest
2. RBW = 1MHz
3. VBW = 3MHz
4. Detector = Peak
5. Sweep time = Auto couple
6. Trace mode = Max hold
7. Trace was allowed to stabilize

Average Measurements above 1GHz (Method VB)

1. Analyzer center frequency was set to the frequency of the radiated spurious emission of interest
2. RBW = 1MHz
3. VBW; if the EUT is configured to transmit with duty cycle $\geq 98\%$, set VBW = 10Hz
If the EUT duty cycle is $< 98\%$, set VBW $\geq 1/T$. T is the minimum transmission duration.
4. As an alternative, the instrument may be set to linear detector mode. Ensure that video filtering is applied in linear voltage domain (rather than in a log or dB domain). Some instruments require linear display mode in order to accomplish this. Others have a setting for Average-VBW Type, which can be set to "Voltage" regardless of the display mode
5. Detector = Peak
6. Sweep time = Auto
7. Trace mode = Max hold
8. Trace was allowed to stabilize

6.8.4. Test Setup

Below 30MHz Test Setup:

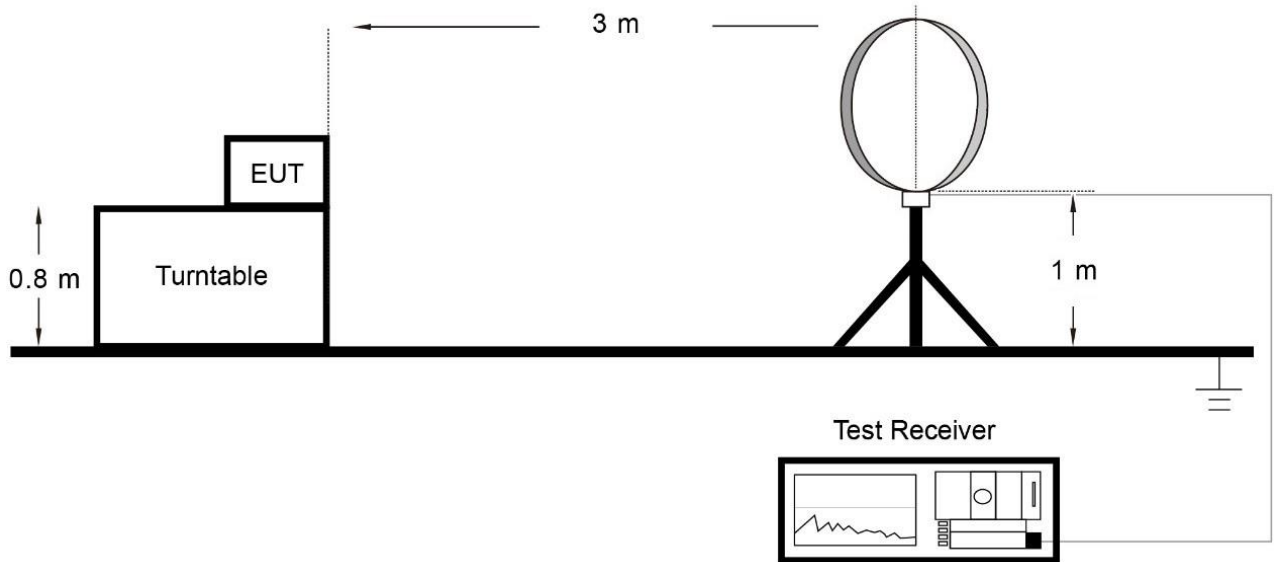

Below 1GHz Test Setup:

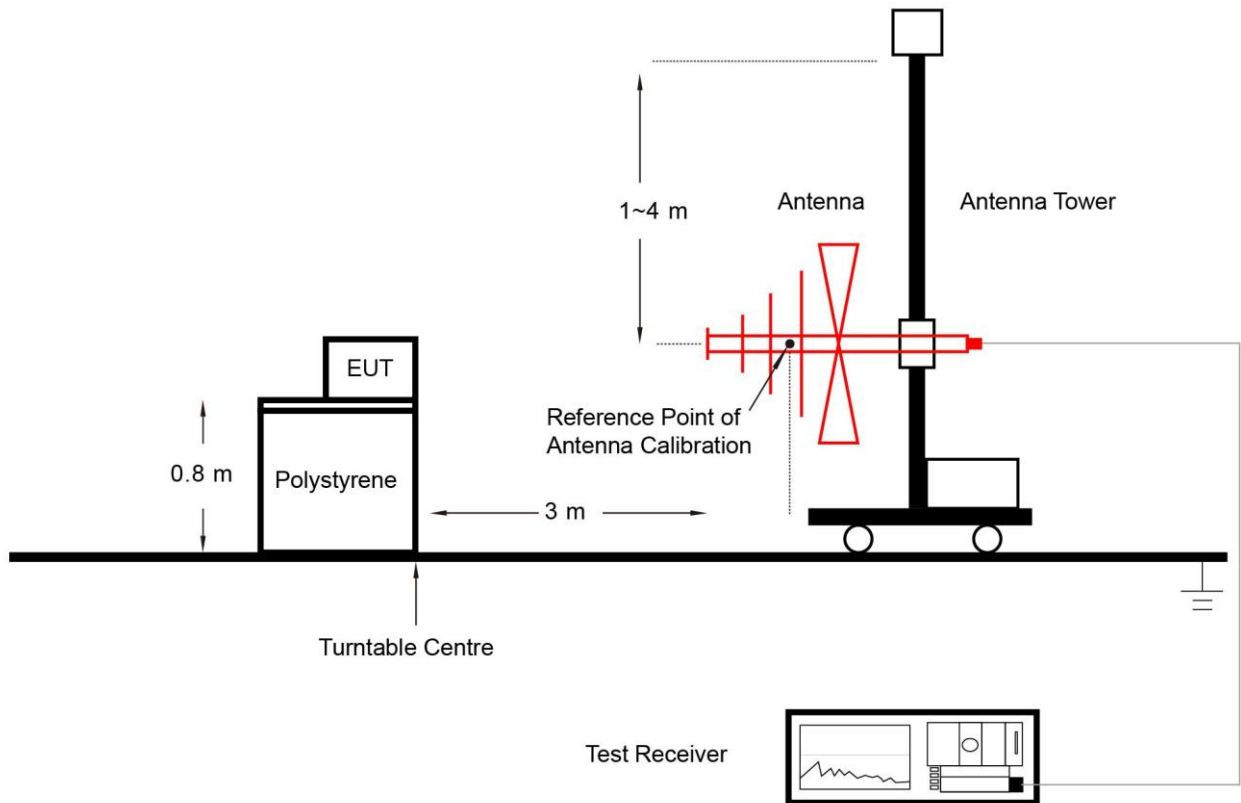

Above 1GHz Test Setup:

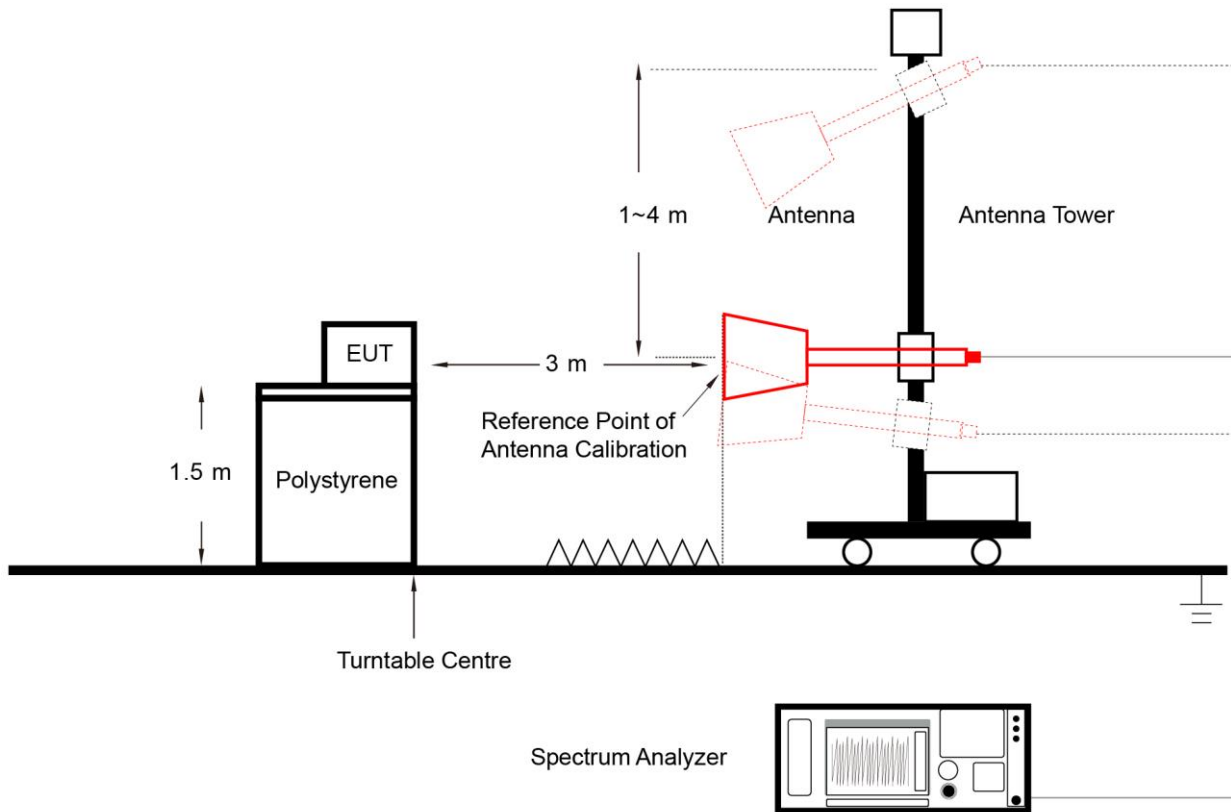

6.8.5. Test Result

Refer to Appendix A.7.

6.9. Radiated Restricted Band Edge Measurement

6.9.1. Test Limit

For 15.205 requirement:

Radiated emissions which fall in the restricted bands, as defined in Section 15.205(a) of FCC part 15, must also comply with the radiated emission limits specified in Section 15.209(a).

Frequency (MHz)	Frequency (MHz)	Frequency (MHz)	Frequency (GHz)
0.090 - 0.110	16.42 - 16.423	399.9 - 410	4.5 - 5.15
¹ 0.495 - 0.505	16.69475 - 16.69525	608 - 614	5.35 - 5.46
2.1735 - 2.1905	16.80425 - 16.80475	960 - 1240	7.25 - 7.75
4.125 - 4.128	25.5 - 25.67	1300 - 1427	8.025 - 8.5
4.17725 - 4.17775	37.5 - 38.25	1435 - 1626.5	9.0 - 9.2
4.20725 - 4.20775	73 - 74.6	1645.5 - 1646.5	9.3 - 9.5
6.215 - 6.218	74.8 - 75.2	1660 - 1710	10.6 - 12.7
6.26775 - 6.26825	108 - 121.94	1718.8 - 1722.2	13.25 - 13.4
6.31175 - 6.31225	123 - 138	2200 - 2300	14.47 - 14.5
8.291 - 8.294	149.9 - 150.05	2310 - 2390	15.35 - 16.2
8.362 - 8.366	156.52475 - 156.52525	2483.5 - 2500	17.7 - 21.4
8.37625 - 8.38675	156.7 - 156.9	2690 - 2900	22.01 - 23.12
8.41425 - 8.41475	162.0125 - 167.17	3260 - 3267	23.6 - 24.0
12.29 - 12.293	167.72 - 173.2	3332 - 3339	31.2 - 31.8
12.51975 - 12.52025	240 - 285	3345.8 - 3358	36.43 - 36.5
12.57675 - 12.57725	322 - 335.4	3600 - 4400	(²)
13.36 - 13.41	--	--	--

For 15.407(b) requirement:

For transmitters operating in the 5.15-5.25 GHz band: All emissions outside of the 5.15-5.35 GHz band shall not exceed an e.i.r.p. of -27 dBm/MHz.

For transmitters operating in the 5.25-5.35 GHz band: All emissions outside of the 5.15-5.35 GHz band shall not exceed an e.i.r.p. of -27 dBm/MHz.

For transmitters operating in the 5.47-5.725 GHz band: All emissions outside of the 5.47-5.725 GHz band shall not exceed an e.i.r.p. of -27 dBm/MHz.

For transmitters operating in the 5.725-5.85 GHz band: All emissions shall be limited to a level of -27 dBm/MHz at 75 MHz or more above or below the band edge increasing linearly to 10 dBm/MHz at 25 MHz above or below the band edge, and from 25 MHz above or below the band edge increasing linearly to a level of 15.6 dBm/MHz at 5 MHz above or below the band edge, and from 5 MHz above or below the band edge increasing linearly to a level of 27 dBm/MHz at the band edge.

Refer to KDB 789033 D02v02r01 G)2)c), as specified in § 15.407(b), emissions above 1000 MHz that are outside of the restricted bands are subject to a maximum emission limit of -27 dBm/MHz (or -17 dBm/MHz as specified in § 15.407(b)(4)). However, an out-of-band emission that complies with both the peak and average limits of § 15.209 is not required to satisfy the -27 dBm/MHz or -17 dBm/MHz maximum emission limit.

All out of band emissions appearing in a restricted band as specified in Section 15.205 of the Title 47CFR must not exceed the limits shown in Table per Section 15.209.

FCC Part 15 Subpart C Paragraph 15.209		
Frequency [MHz]	Field Strength [μV/m]	Measured Distance [Meters]
0.009 - 0.490	2400/F (kHz)	300
0.490 - 1.705	24000/F (kHz)	30
1.705 - 30	30	30
30 - 88	100	3
88 - 216	150	3
216 - 960	200	3
Above 960	500	3

6.9.2. Test Procedure

KDB 789033 D02v02r01- Section II)G)

6.9.3. Test Setting

Peak Field Strength Measurements

1. Analyzer center frequency was set to the frequency of the radiated spurious emission of interest
2. RBW = 1MHz
3. VBW = 3MHz
4. Detector = peak
5. Sweep time = auto couple
6. Trace mode = max hold
7. Trace was allowed to stabilize

Average Field Strength Measurements

1. Analyzer center frequency was set to the frequency of the radiated spurious emission of interest
2. RBW = 1MHz
3. VBW; If the EUT is configured to transmit with duty cycle $\geq 98\%$, set VBW = 10 Hz.
If the EUT duty cycle is $< 98\%$, set VBW $\geq 1/T$. T is the minimum transmission duration.
4. As an alternative, the instrument may be set to linear detector mode. Ensure that video filtering is applied in linear voltage domain (rather than in a log or dB domain). Some instruments require linear display mode in order to accomplish this. Others have a setting for Average-VBW Type, which can be set to "Voltage" regardless of the display mode
5. Detector = Peak
6. Sweep time = auto
7. Trace mode = max hold
8. Allow max hold to run for at least 50 times (1/duty cycle) traces

6.9.4. Test Setup

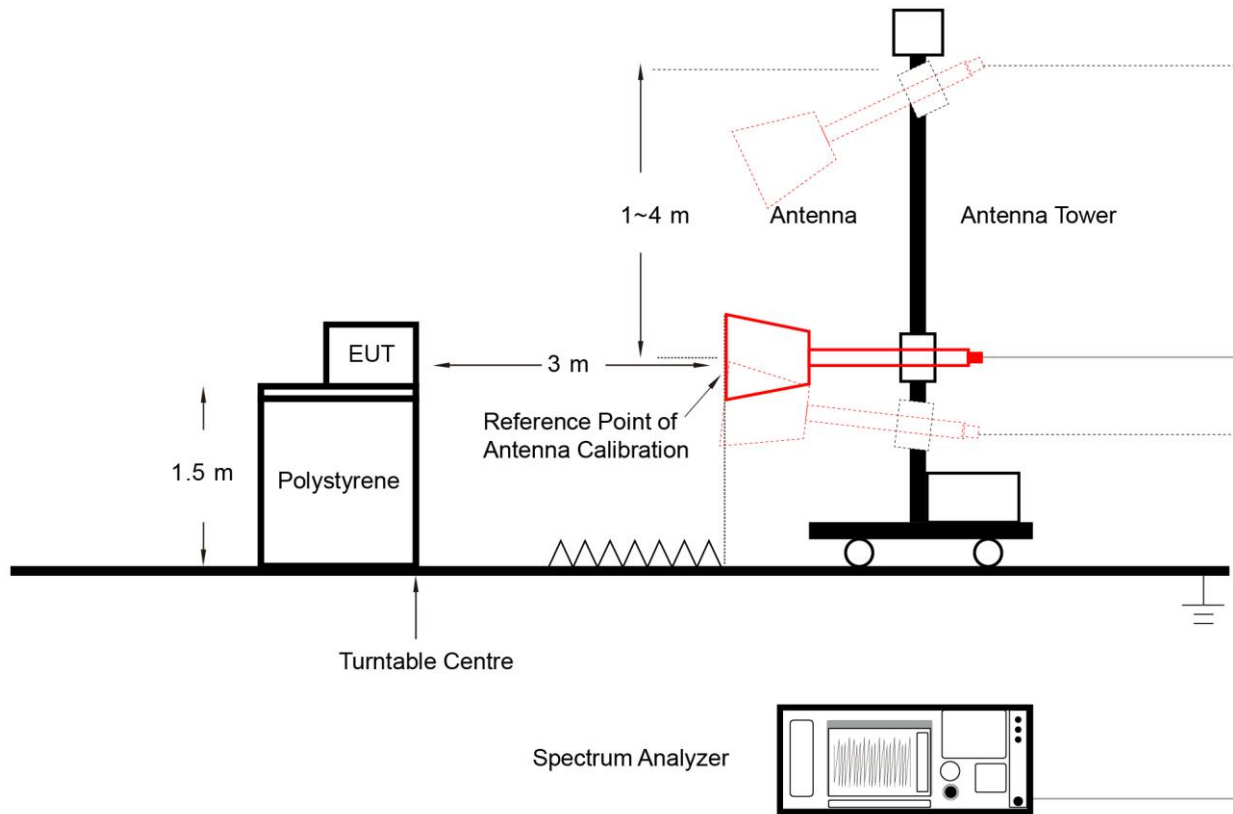

6.9.5. Test Result

Refer to Appendix A.8.

6.10. AC Conducted Emissions Measurement

6.10.1. Test Limit

FCC Part 15.207 Limits		
Frequency (MHz)	QP (dB μ V)	AV (dB μ V)
0.15 - 0.50	66 - 56	56 - 46
0.50 - 5.0	56	46
5.0 - 30	60	50

Note 1: The lower limit shall apply at the transition frequencies.

Note 2: The limit decreases linearly with the logarithm of the frequency in the range 0.15MHz to 0.5MHz.

6.10.2. Test Setup

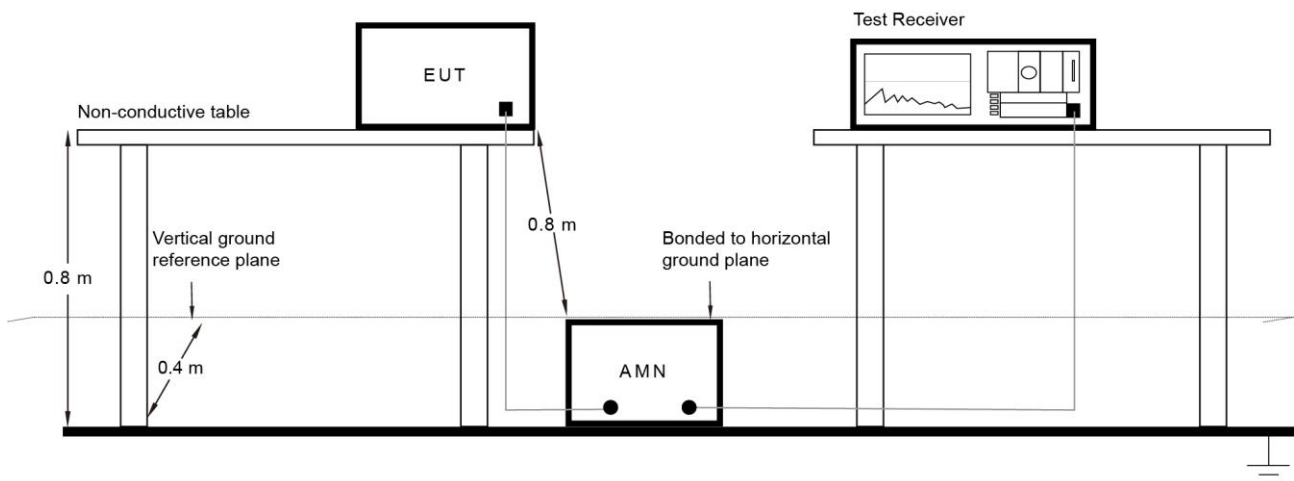

6.10.3. Test Result

Refer to Appendix A.9.

Appendix A – Test Result

A.1 Duty Cycle Test Result

Test Site	WZ-SR4	Test Engineer	Jeff Yang
Test Date	2024-05-16		

Test Mode	Duty Cycle
802.11a	92.02%
802.11ac-VHT20	94.24%
802.11ac-VHT40	89.98%
802.11ac-VHT80	81.40%

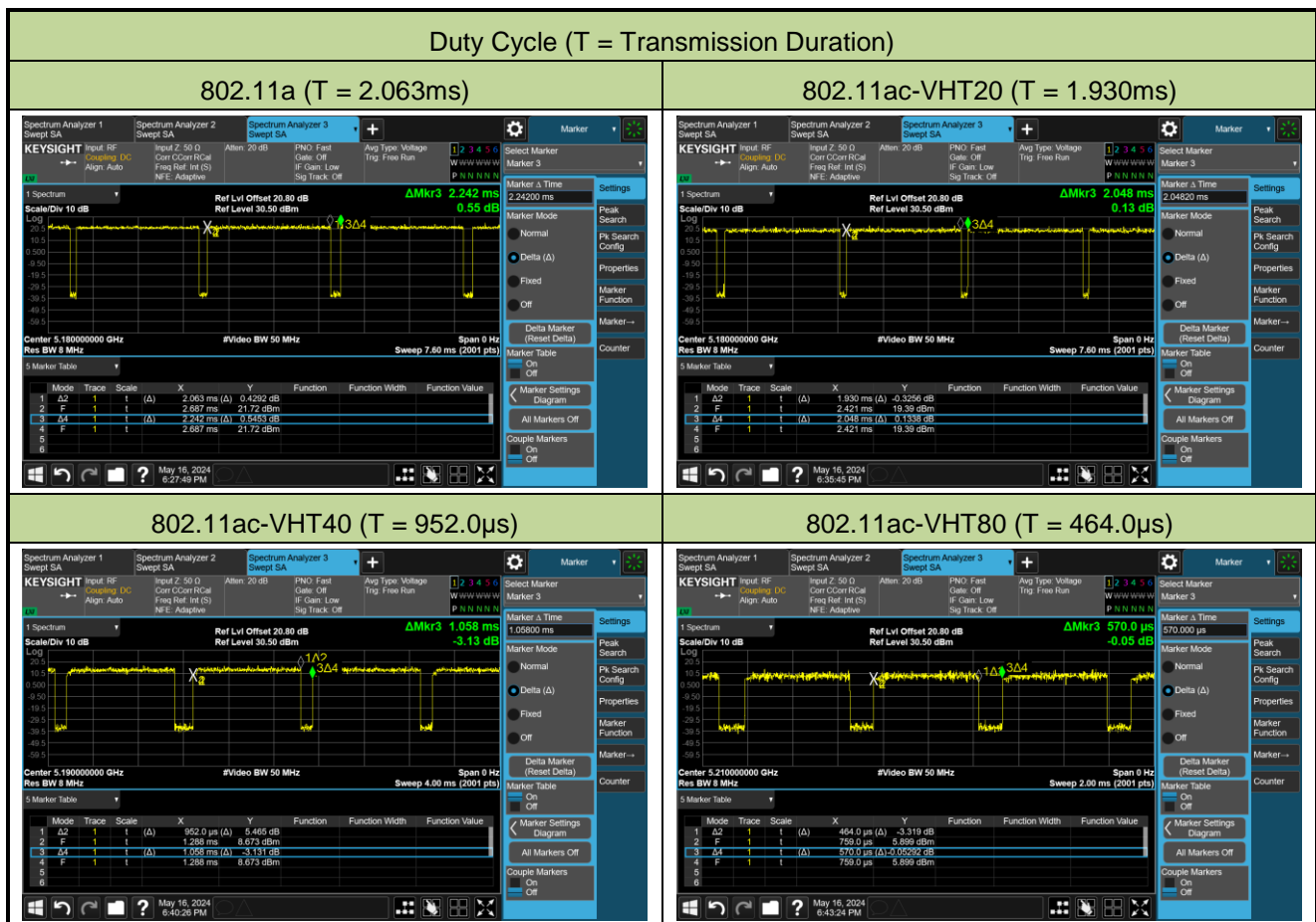

A.2 26dB & 99% Bandwidth Test Result

Test Site	WZ-SR4	Test Engineer	Jeff Yang
Test Date	2024-06-13		

Test Mode	Data Rate/ MCS	Channel No.	Frequency (MHz)	26dB Bandwidth (MHz)	99% Bandwidth (MHz)
11a	6Mbps	36	5180	22.10	16.421
11a	6Mbps	44	5220	21.74	16.378
11a	6Mbps	48	5240	22.03	16.348
11a	6Mbps	52	5260	21.30	16.326
11a	6Mbps	60	5300	21.30	16.315
11a	6Mbps	64	5320	22.38	16.429
11a	6Mbps	100	5500	22.42	16.370
11a	6Mbps	116	5580	27.88	16.726
11a	6Mbps	140	5700	23.84	16.482
11a	6Mbps	144	5720	32.73	17.403
11a	6Mbps	149	5745	33.27	17.399
11a	6Mbps	157	5785	29.37	17.174
11a	6Mbps	165	5825	33.25	17.598
11ac-VHT20	MCS0	36	5180	22.22	17.517
11ac-VHT20	MCS0	44	5220	21.92	17.507
11ac-VHT20	MCS0	48	5240	21.82	17.479
11ac-VHT20	MCS0	52	5260	22.91	17.551
11ac-VHT20	MCS0	60	5300	23.00	17.545
11ac-VHT20	MCS0	64	5320	22.47	17.557
11ac-VHT20	MCS0	100	5500	27.22	17.676
11ac-VHT20	MCS0	116	5580	32.24	18.170
11ac-VHT20	MCS0	140	5700	21.81	17.469
11ac-VHT20	MCS0	144	5720	31.56	18.029
11ac-VHT20	MCS0	149	5745	31.92	18.052
11ac-VHT20	MCS0	157	5785	32.40	17.946
11ac-VHT20	MCS0	165	5825	32.55	18.127

Test Mode	Data Rate/ MCS	Channel No.	Frequency (MHz)	26dB Bandwidth (MHz)	99% Bandwidth (MHz)
11ac-VHT40	MCS0	38	5190	40.34	35.781
11ac-VHT40	MCS0	46	5230	61.60	36.318
11ac-VHT40	MCS0	54	5270	63.13	36.378
11ac-VHT40	MCS0	62	5310	40.44	35.783
11ac-VHT40	MCS0	102	5510	42.45	35.820
11ac-VHT40	MCS0	110	5550	77.64	39.075
11ac-VHT40	MCS0	134	5670	47.27	36.050
11ac-VHT40	MCS0	142	5710	75.74	37.578
11ac-VHT40	MCS0	151	5755	76.92	38.566
11ac-VHT40	MCS0	159	5795	76.22	37.740
11ac-VHT80	MCS0	42	5210	82.59	75.100
11ac-VHT80	MCS0	58	5290	81.98	74.975
11ac-VHT80	MCS0	106	5530	82.29	75.097
11ac-VHT80	MCS0	122	5610	131.30	75.991
11ac-VHT80	MCS0	138	5690	106.10	75.615
11ac-VHT80	MCS0	155	5775	109.60	75.654

Test Mode	Data Rate/ MCS	Channel No.	Frequency (MHz)	F _H (MHz)	Limit (MHz)
802.11a	6Mbps	48	5240	5248.17	< 5250
802.11ac-VHT20	MCS0	48	5240	5248.74	< 5250
802.11ac-VHT40	MCS0	46	5230	5248.16	< 5250
802.11ac-VHT80	MCS0	42	5210	5247.55	< 5250

Note: $F_H = \text{Centre frequency} + 99\% \text{ OBW} / 2$.

For example, 802.11a 5240MHz, $F_H = 5240 \text{ MHz} + 16.348 \text{ MHz} / 2 = 5248.17 \text{ MHz}$.

802.11a 26dB Bandwidth & 99% Bandwidth

Channel 36 (5180MHz)



Channel 44 (5220MHz)

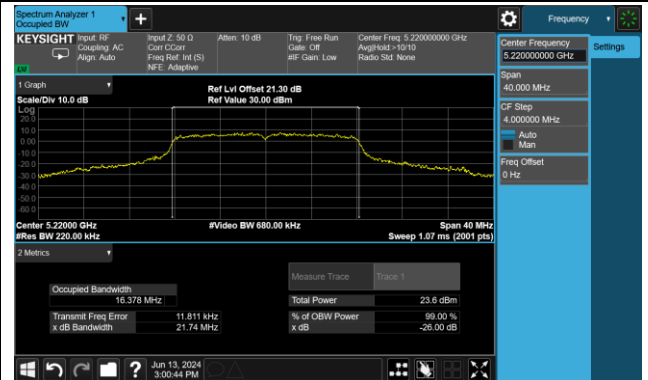

Channel 48 (5240MHz)

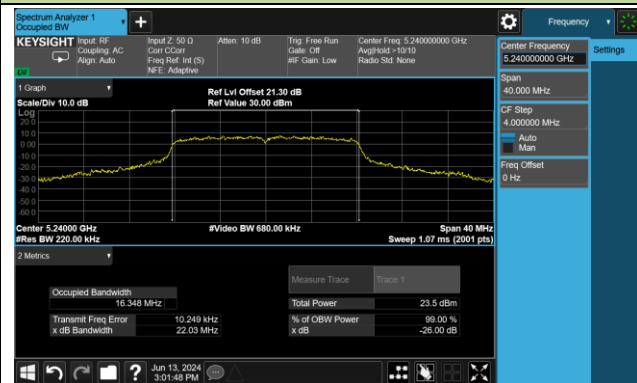

Channel 52 (5260MHz)

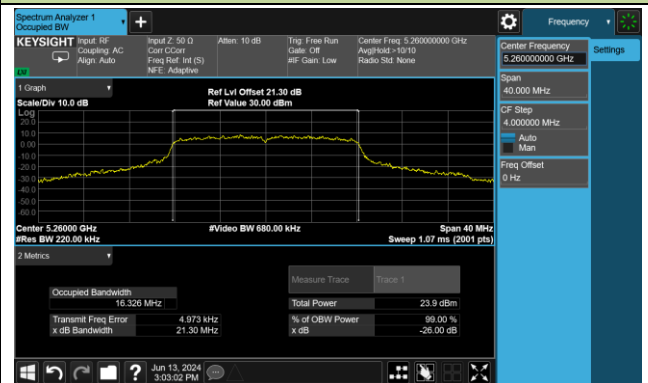

Channel 60 (5300MHz)

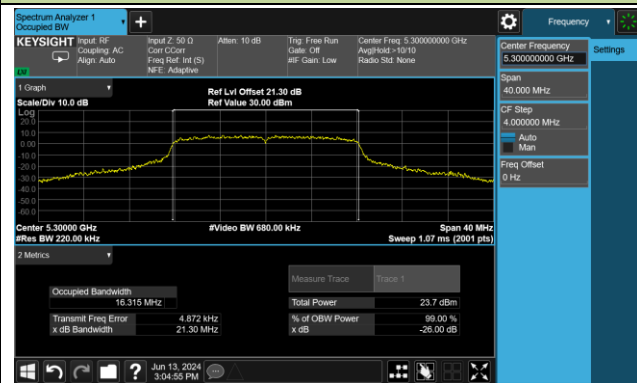

Channel 64 (5320MHz)



Channel 100 (5500MHz)



Channel 116 (5580MHz)



802.11a 26dB Bandwidth & 99% Bandwidth

Channel 140 (5700MHz)



Channel 144(5720MHz)

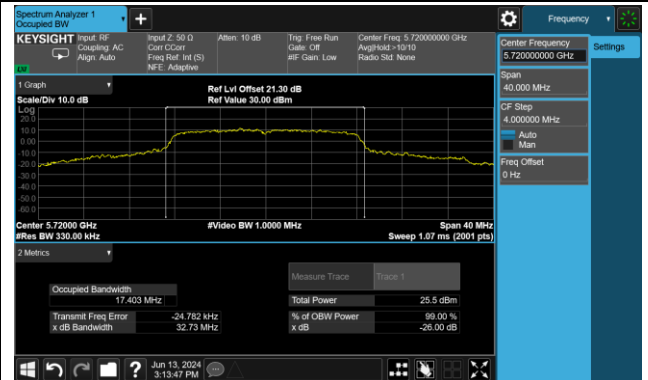

Channel 149 (5745MHz)

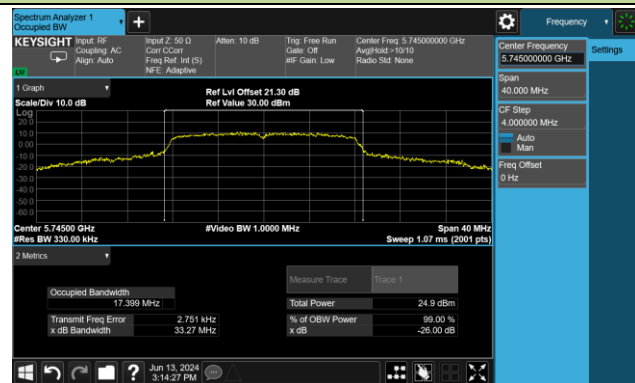

Channel 157 (5785MHz)



Channel 165 (5825MHz)

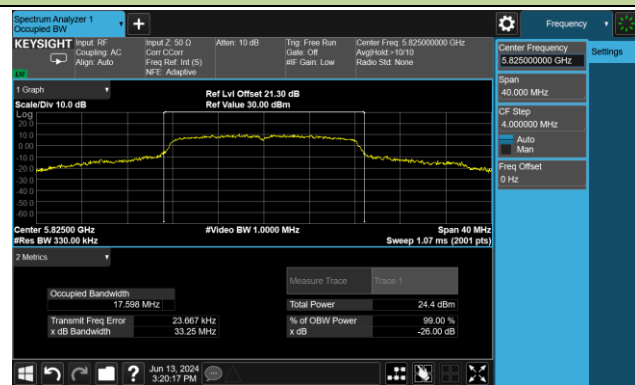

802.11ac-VHT20 26dB Bandwidth & 99% Bandwidth

Channel 36 (5180MHz)

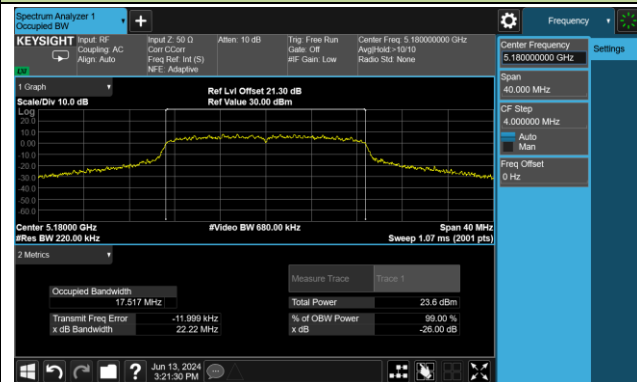

Channel 44 (5220MHz)



Channel 48 (5240MHz)

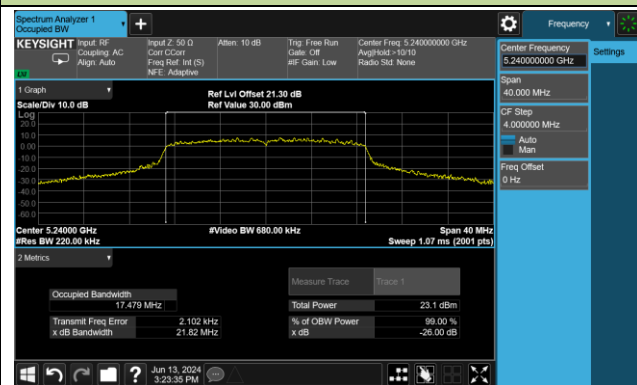

Channel 52 (5260MHz)

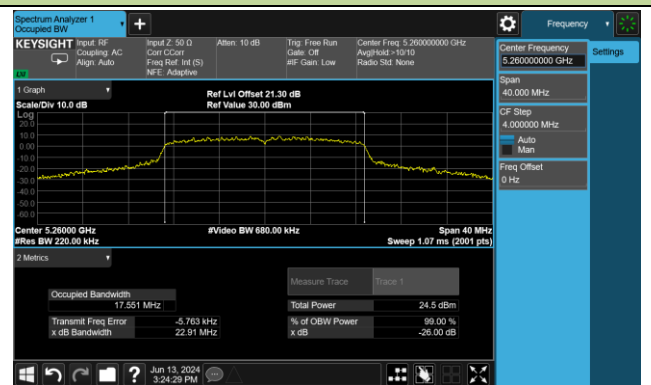

Channel 60 (5300MHz)

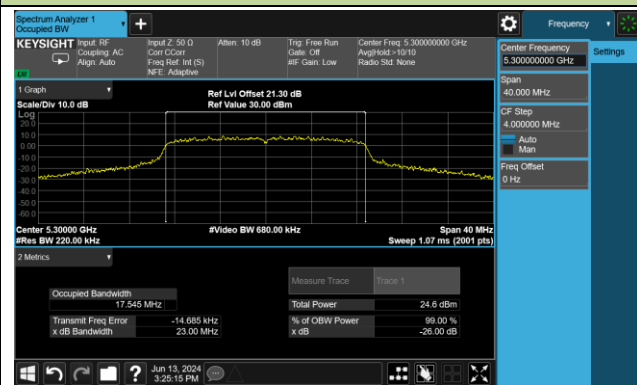

Channel 64 (5320MHz)

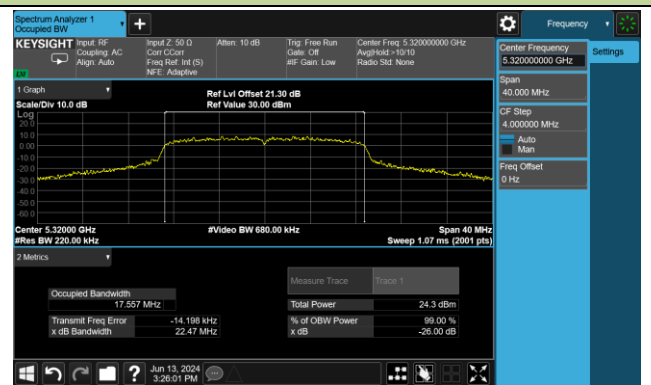

Channel 100 (5500MHz)

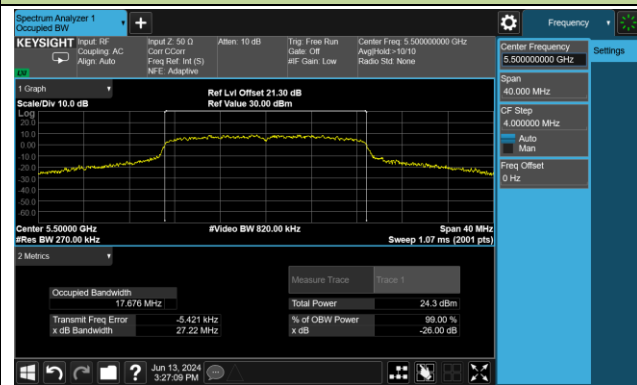

Channel 116 (5580MHz)

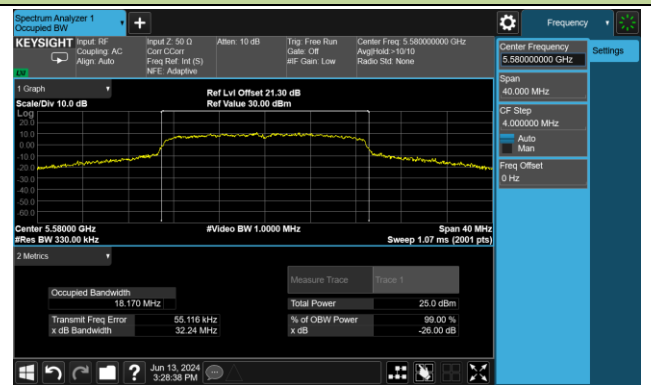

802.11ac-VHT20 26dB Bandwidth & 99% Bandwidth

Channel 140 (5700MHz)

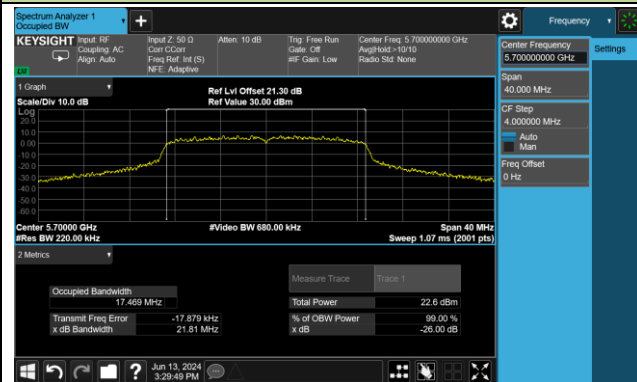

Channel 144(5720MHz)

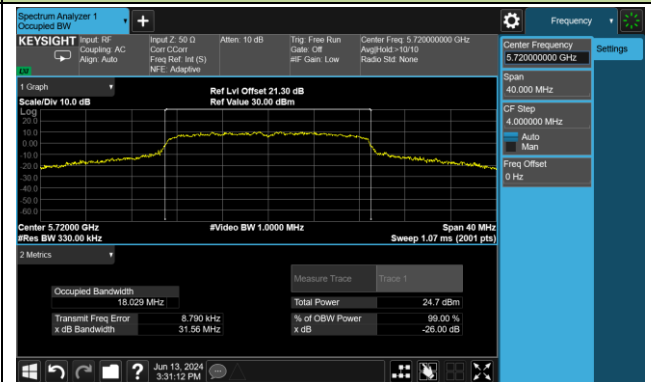

Channel 149 (5745MHz)



Channel 157 (5785MHz)

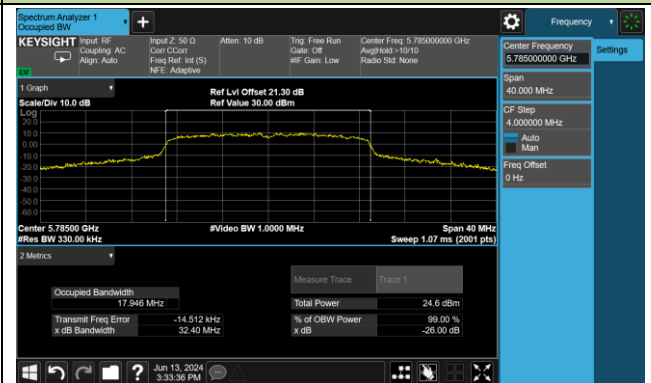

Channel 165 (5825MHz)

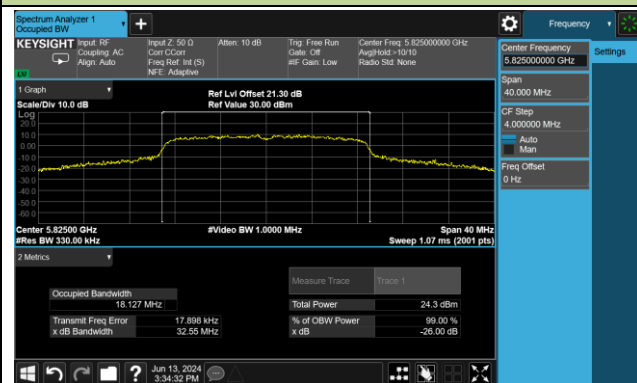

802.11ac-VHT40 26dB Bandwidth & 99% Bandwidth

Channel 38 (5190MHz)



Channel 46 (5230MHz)

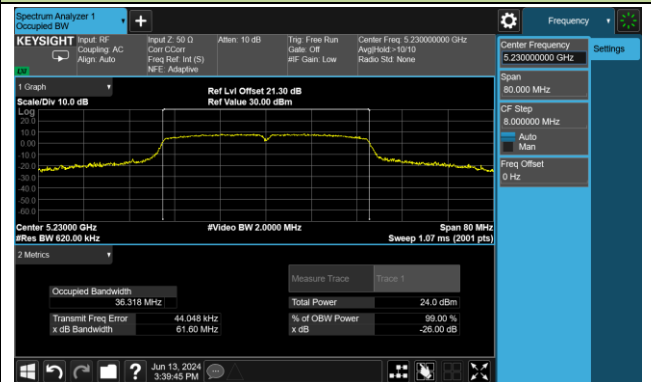

Channel 54 (5270MHz)

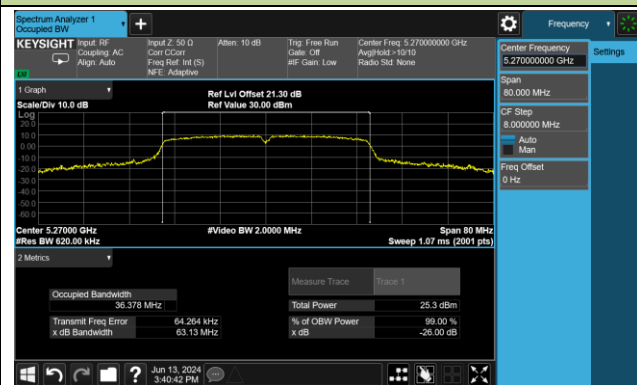

Channel 62 (5310MHz)

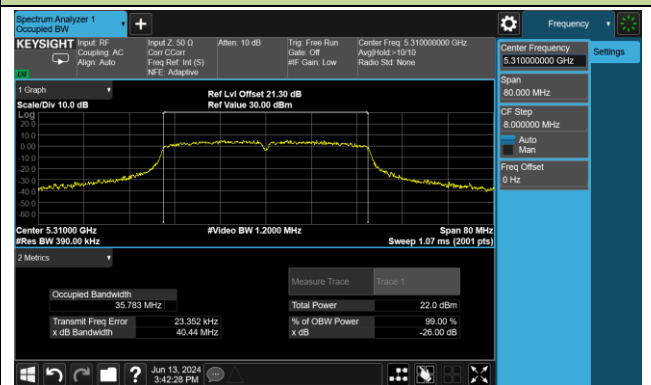

Channel 102 (5510MHz)

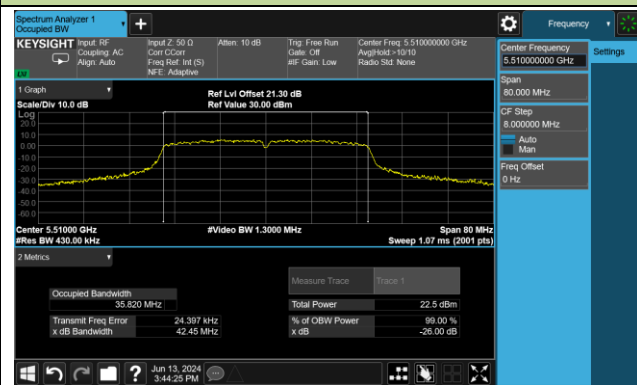

Channel 110 (5550MHz)

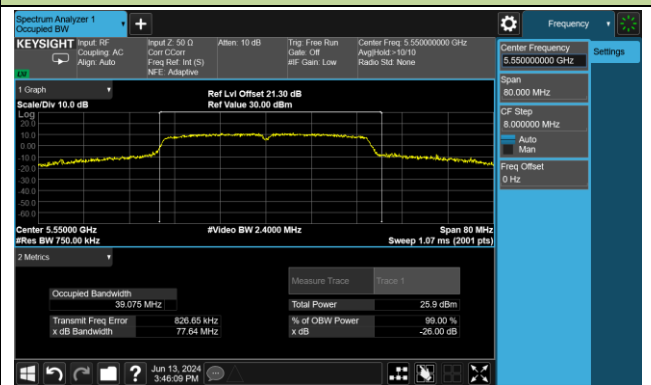

Channel 134 (5670MHz)

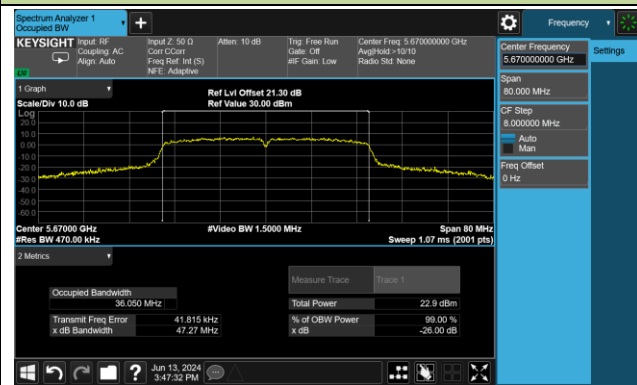

Channel 142(5710MHz)



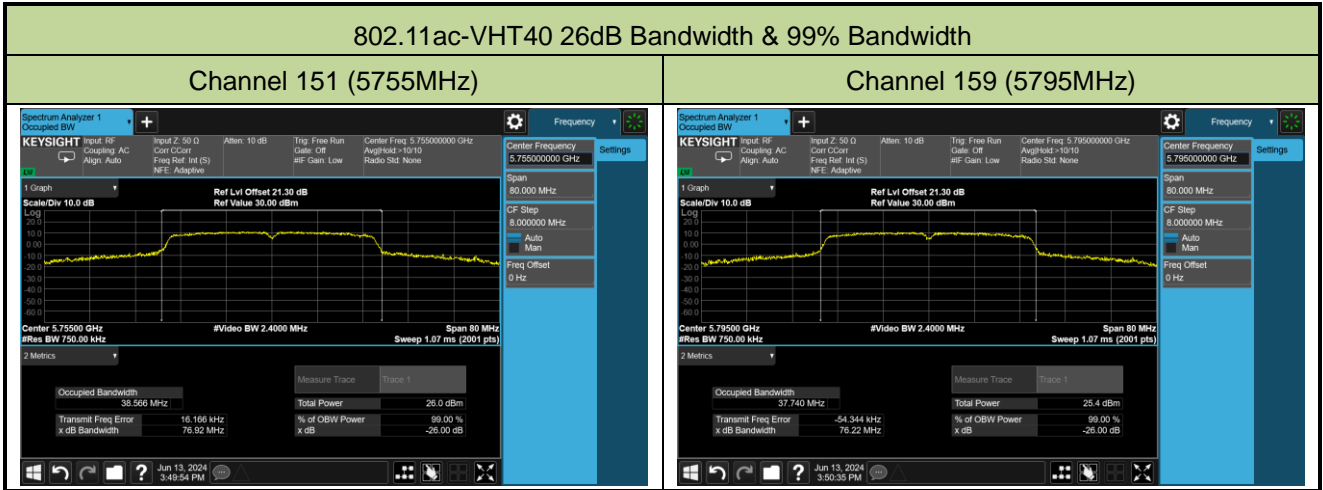

802.11ac-VHT80 26dB Bandwidth & 99% Bandwidth

Channel 42 (5210MHz)

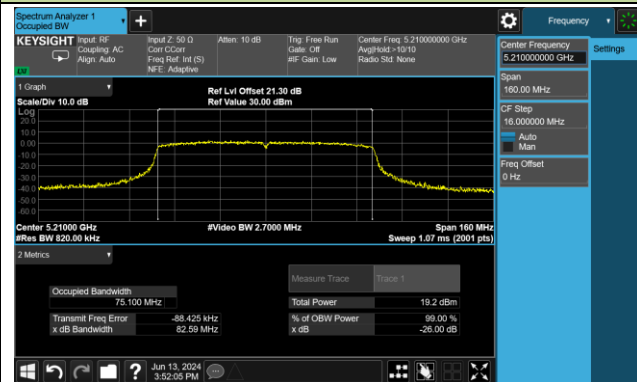

Channel 58 (5290MHz)

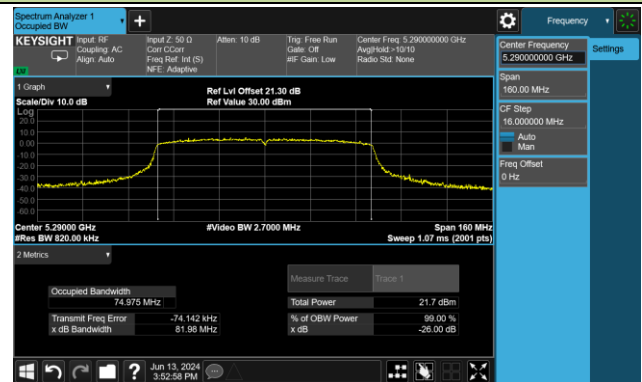

Channel 106 (5530MHz)

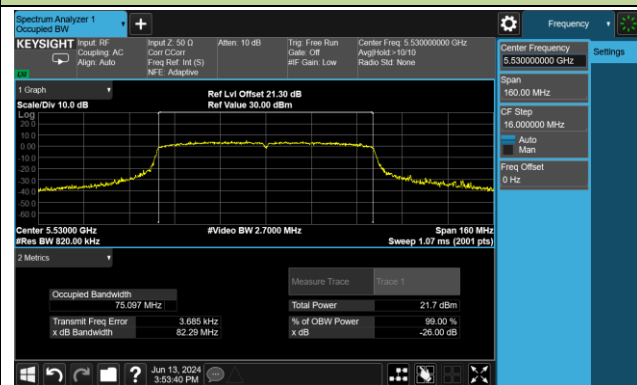

Channel 122 (5610MHz)

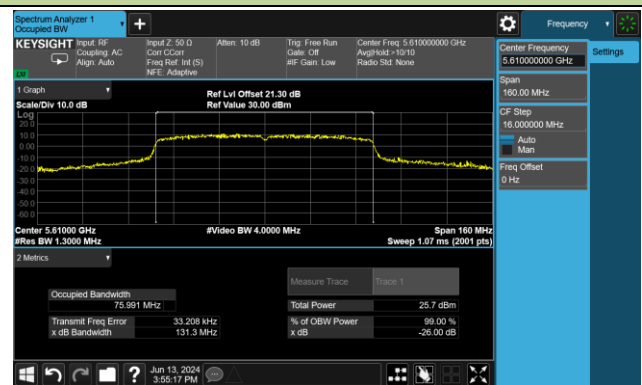

Channel 138 (5690MHz)



Channel 155 (5775MHz)

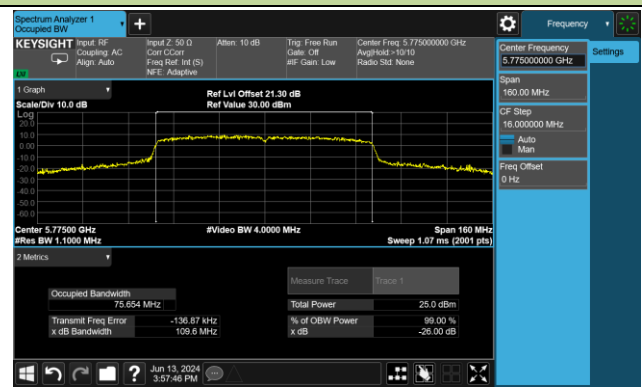

A.3 6dB Bandwidth Test Result

Test Site	WZ-SR4	Test Engineer	Jeff Yang
Test Date	2024-05-20		

Test Mode	Data Rate/ MCS	Channel No.	Frequency (MHz)	6dB Bandwidth (MHz)	Limit (MHz)
11a	6Mbps	149	5745	14.82	≥0.5
11a	6Mbps	157	5785	15.23	≥0.5
11a	6Mbps	165	5825	15.07	≥0.5
11ac-VHT20	MCS0	149	5745	15.04	≥0.5
11ac-VHT20	MCS0	157	5785	15.94	≥0.5
11ac-VHT20	MCS0	165	5825	14.11	≥0.5
11ac-VHT40	MCS0	151	5755	35.11	≥0.5
11ac-VHT40	MCS0	159	5795	35.11	≥0.5
11ac-VHT80	MCS0	155	5775	72.65	≥0.5

802.11a 6dB Bandwidth

Channel 149 (5745MHz)

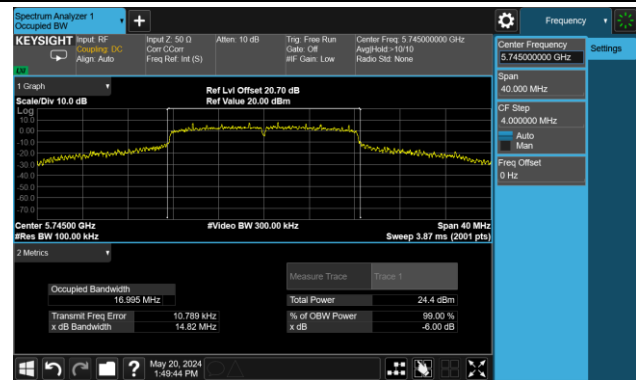

Channel 157 (5785MHz)

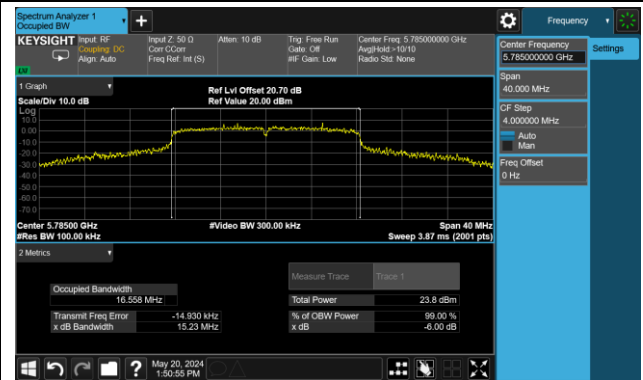

Channel 165 (5825MHz)

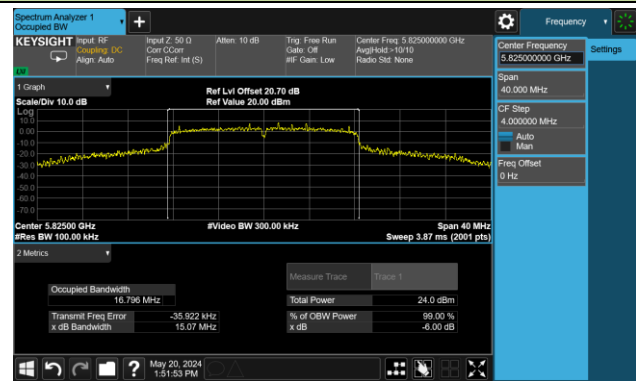

802.11ac-VHT20 6dB Bandwidth

Channel 149 (5745MHz)

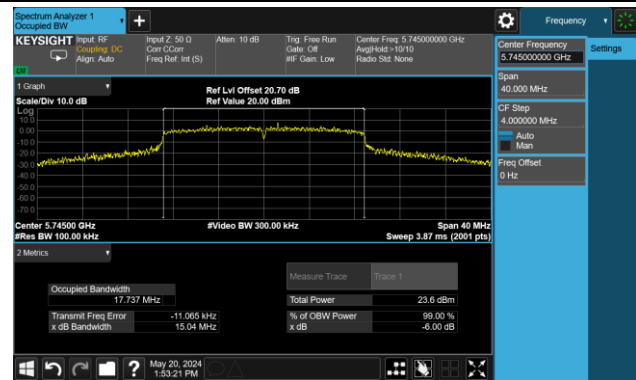

Channel 157 (5785MHz)

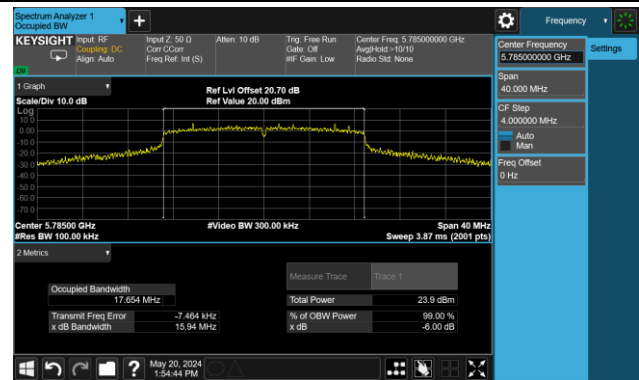

Channel 165 (5825MHz)

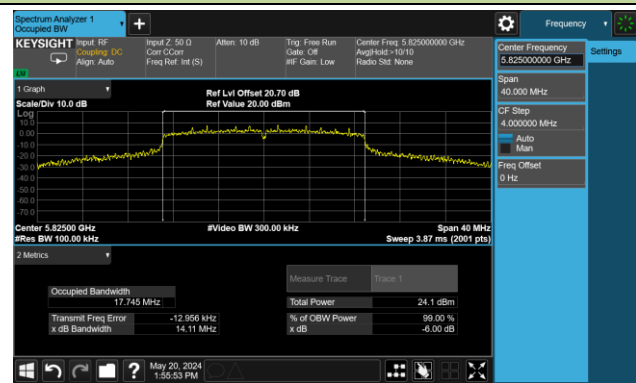

802.11ac-VHT40 6dB Bandwidth

Channel 151 (5755MHz)

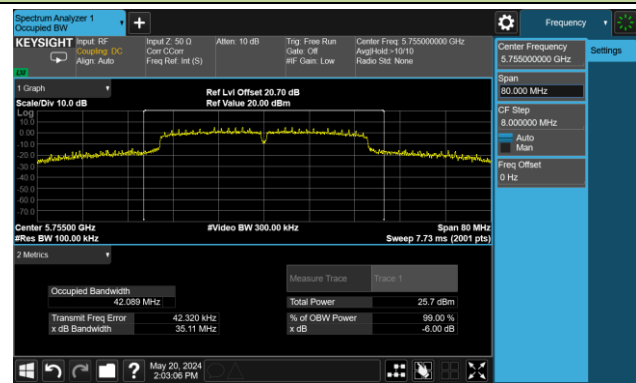

Channel 159 (5795MHz)

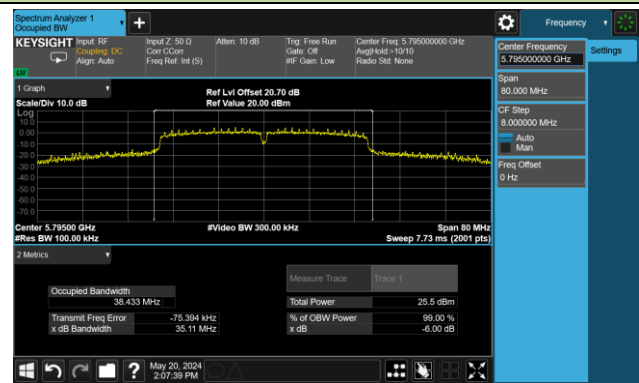

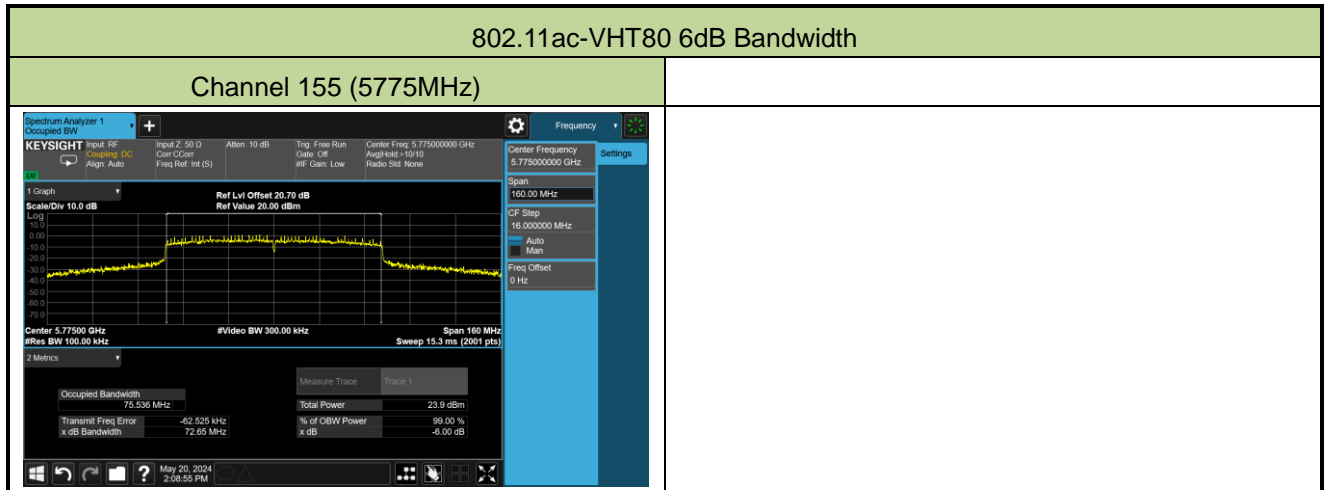

A.4 Output Power Test Result

Test Site	WZ-SR4	Test Engineer	Jeff Yang
Test Date	2024-05-08 ~ 2024-05-20		

Test Mode	Data Rate MCS	Channel No.	Freq. (MHz)	Average Power (dBm)	Power Limit (dBm)
11a	6Mbps	36	5180	18.02	≤ 23.98
11a	6Mbps	44	5220	17.89	≤ 23.98
11a	6Mbps	48	5240	17.77	≤ 23.98
11a	6Mbps	52	5260	17.71	≤ 23.98
11a	6Mbps	60	5300	17.71	≤ 23.98
11a	6Mbps	64	5320	18.44	≤ 23.98
11a	6Mbps	100	5500	16.76	≤ 23.98
11a	6Mbps	116	5580	17.72	≤ 23.98
11a	6Mbps	140	5700	16.61	≤ 23.98
11a	6Mbps	144	5720	18.27	≤ 23.98
11a	6Mbps	149	5745	18.41	≤ 30.00
11a	6Mbps	157	5785	18.25	≤ 30.00
11a	6Mbps	165	5825	18.24	≤ 30.00
11ac-VHT20	MCS0	36	5180	17.78	≤ 23.98
11ac-VHT20	MCS0	44	5220	17.69	≤ 23.98
11ac-VHT20	MCS0	48	5240	17.61	≤ 23.98
11ac-VHT20	MCS0	52	5260	18.43	≤ 23.98
11ac-VHT20	MCS0	60	5300	18.42	≤ 23.98
11ac-VHT20	MCS0	64	5320	18.25	≤ 23.98
11ac-VHT20	MCS0	100	5500	18.12	≤ 23.98
11ac-VHT20	MCS0	116	5580	18.35	≤ 23.98
11ac-VHT20	MCS0	140	5700	15.44	≤ 23.98
11ac-VHT20	MCS0	144	5720	18.12	≤ 23.98
11ac-VHT20	MCS0	149	5745	18.25	≤ 30.00
11ac-VHT20	MCS0	157	5785	18.07	≤ 30.00
11ac-VHT20	MCS0	165	5825	18.06	≤ 30.00

Test Mode	Data Rate MCS	Channel No.	Freq. (MHz)	Average Power (dBm)	Power Limit (dBm)
11ac-VHT40	MCS0	38	5190	13.75	≤ 23.98
11ac-VHT40	MCS0	46	5230	18.13	≤ 23.98
11ac-VHT40	MCS0	54	5270	18.92	≤ 23.98
11ac-VHT40	MCS0	62	5310	15.52	≤ 23.98
11ac-VHT40	MCS0	102	5510	15.15	≤ 23.98
11ac-VHT40	MCS0	110	5550	18.79	≤ 23.98
11ac-VHT40	MCS0	134	5670	16.06	≤ 23.98
11ac-VHT40	MCS0	142	5710	18.73	≤ 23.98
11ac-VHT40	MCS0	151	5755	18.88	≤ 30.00
11ac-VHT40	MCS0	159	5795	18.58	≤ 30.00
11ac-VHT80	MCS0	42	5210	12.41	≤ 23.98
11ac-VHT80	MCS0	58	5290	14.19	≤ 23.98
11ac-VHT80	MCS0	106	5530	13.85	≤ 23.98
11ac-VHT80	MCS0	122	5610	17.34	≤ 23.98
11ac-VHT80	MCS0	138	5690	17.04	≤ 23.98
11ac-VHT80	MCS0	155	5775	17.12	≤ 30.00

Note: For Band-Crossing channel, Average Power Limit = 23.98dBm or $11+10*\log_{10}EBW_{2c}$ which is less.

A.5 Power Spectral Density Test Result

Test Site	WZ-SR4	Test Engineer	Jeff Yang
Test Date	2024-05-20		
Test Item	Power Spectral Density (UNII-Band 1 & UNII-2a & UNII-2c)		

Test Mode	Data Rate/ MCS	Channel No.	Freq. (MHz)	AVPSD (dBm/MHz)	Duty Cycle (%)	Total PSD (dBm/MHz)	PSD Limit (dBm/MHz)
11a	6Mbps	36	5180	6.276	92.02	6.637	≤ 11.00
11a	6Mbps	44	5220	6.129	92.02	6.490	≤ 11.00
11a	6Mbps	48	5240	5.957	92.02	6.318	≤ 11.00
11a	6Mbps	52	5260	5.861	92.02	6.222	≤ 11.00
11a	6Mbps	60	5300	5.958	92.02	6.319	≤ 11.00
11a	6Mbps	64	5320	6.749	92.02	7.110	≤ 11.00
11a	6Mbps	100	5500	5.644	92.02	6.005	≤ 11.00
11a	6Mbps	116	5580	4.336	92.02	4.697	≤ 11.00
11a	6Mbps	140	5700	5.787	92.02	6.148	≤ 11.00
11a	6Mbps	144	5720	6.695	92.02	7.056	≤ 11.00
11ac-VHT20	MCS0	36	5180	5.980	94.24	6.238	≤ 11.00
11ac-VHT20	MCS0	44	5220	5.819	94.24	6.077	≤ 11.00
11ac-VHT20	MCS0	48	5240	5.709	94.24	5.967	≤ 11.00
11ac-VHT20	MCS0	52	5260	6.516	94.24	6.774	≤ 11.00
11ac-VHT20	MCS0	60	5300	6.565	94.24	6.823	≤ 11.00
11ac-VHT20	MCS0	64	5320	6.312	94.24	6.570	≤ 11.00
11ac-VHT20	MCS0	100	5500	5.550	94.24	5.808	≤ 11.00
11ac-VHT20	MCS0	116	5580	6.469	94.24	6.727	≤ 11.00
11ac-VHT20	MCS0	140	5700	4.386	94.24	4.644	≤ 11.00
11ac-VHT20	MCS0	144	5720	6.219	94.24	6.477	≤ 11.00
11ac-VHT40	MCS0	38	5190	-0.661	89.98	-0.202	≤ 11.00
11ac-VHT40	MCS0	46	5230	3.250	89.98	3.709	≤ 11.00
11ac-VHT40	MCS0	54	5270	3.889	89.98	4.348	≤ 11.00
11ac-VHT40	MCS0	62	5310	0.924	89.98	1.383	≤ 11.00
11ac-VHT40	MCS0	102	5510	0.135	89.98	0.594	≤ 11.00
11ac-VHT40	MCS0	110	5550	3.250	89.98	3.709	≤ 11.00
11ac-VHT40	MCS0	134	5670	1.177	89.98	1.636	≤ 11.00
11ac-VHT40	MCS0	142	5710	3.350	89.98	3.809	≤ 11.00

Test Mode	Data Rate/ MCS	Channel No.	Freq. (MHz)	AVPSD (dBm/MHz)	Duty Cycle (%)	Total PSD (dBm/MHz)	PSD Limit (dBm/MHz)
11ac-VHT80	MCS0	42	5210	-5.201	81.40	-4.307	≤ 11.00
11ac-VHT80	MCS0	58	5290	-3.853	81.40	-2.959	≤ 11.00
11ac-VHT80	MCS0	106	5530	-4.707	81.40	-3.813	≤ 11.00
11ac-VHT80	MCS0	122	5610	-1.609	81.40	-0.715	≤ 11.00
11ac-VHT80	MCS0	138	5690	-1.972	81.40	-1.078	≤ 11.00

Note:

If Duty Cycle ≥ 98%, Total PSD (dBm/MHz) = AVPSD (dBm/MHz).

If Duty Cycle < 98%, Total PSD (dBm/MHz) = AVPSD (dBm/MHz) + 10*log(1/Duty Cycle).

Test Site	WZ-SR4	Test Engineer	Jeff Yang
Test Date	2024-05-20		
Test Item	Power Spectral Density (UNII-Band 3)		

Test Mode	Data Rate/ MCS	Channel No.	Freq. (MHz)	AVPSD (dBm/ 510kHz)	Duty Cycle (%)	Total PSD (dBm/ 510kHz)	PSD Limit (dBm/ 500kHz)
11a	6Mbps	149	5745	4.264	92.02	4.625	≤ 30.00
11a	6Mbps	157	5785	4.061	92.02	4.422	≤ 30.00
11a	6Mbps	165	5825	4.083	92.02	4.444	≤ 30.00
11ac-VHT20	MCS0	149	5745	3.650	94.24	3.908	≤ 30.00
11ac-VHT20	MCS0	157	5785	3.481	94.24	3.739	≤ 30.00
11ac-VHT20	MCS0	165	5825	3.583	94.24	3.841	≤ 30.00
11ac-VHT40	MCS0	151	5755	0.692	89.98	1.151	≤ 30.00
11ac-VHT40	MCS0	159	5795	0.652	89.98	1.111	≤ 30.00
11ac-VHT80	MCS0	155	5775	-4.039	81.40	-3.145	≤ 30.00

Note:

If Duty Cycle ≥ 98%, Total PSD (dBm/510kHz) = AVPSD (dBm/510kHz).

If Duty Cycle < 98%, Total PSD (dBm/510kHz) = AVPSD (dBm/510kHz) + 10*log(1/Duty Cycle).

802.11a Power Spectral Density

Channel 36 (5180MHz)

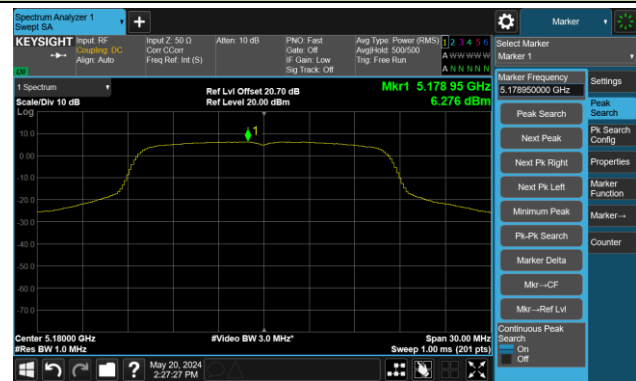

Channel 44 (5220MHz)

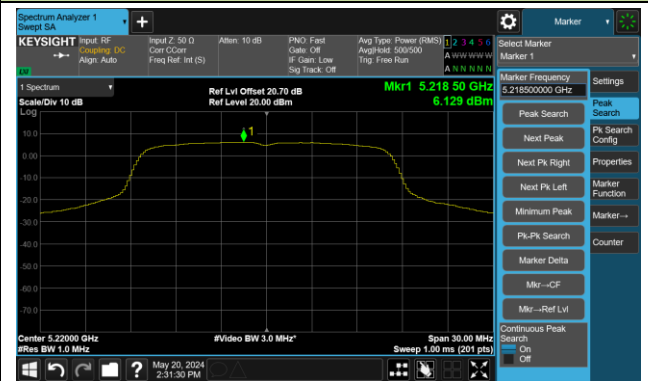

Channel 48 (5240MHz)

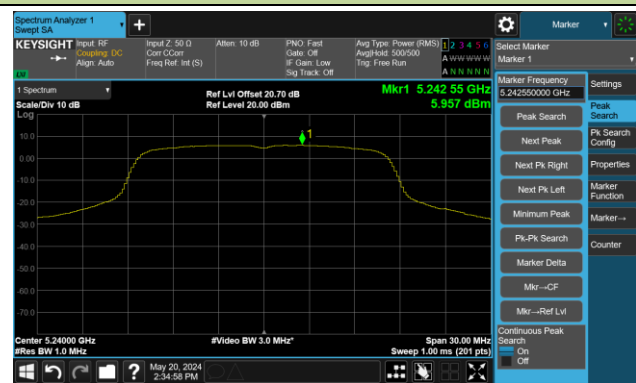

Channel 52 (5260MHz)



Channel 60 (5300MHz)

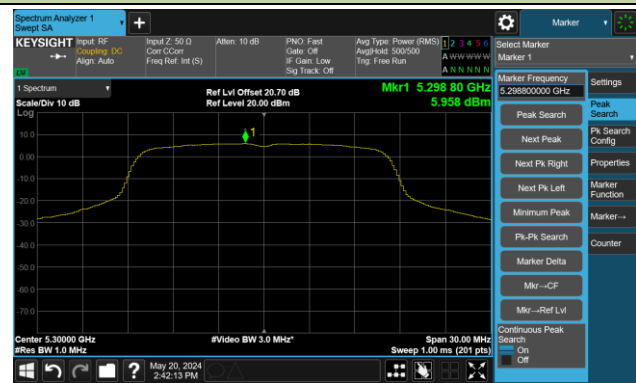

Channel 64 (5320MHz)

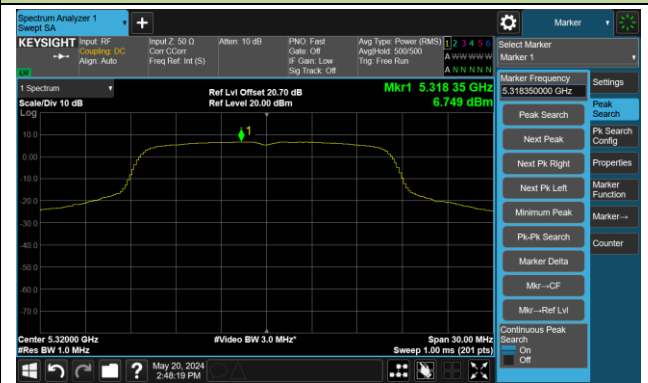

Channel 100 (5500MHz)

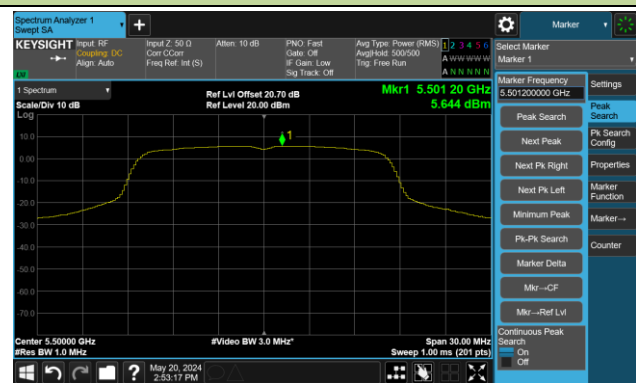

Channel 116 (5580MHz)

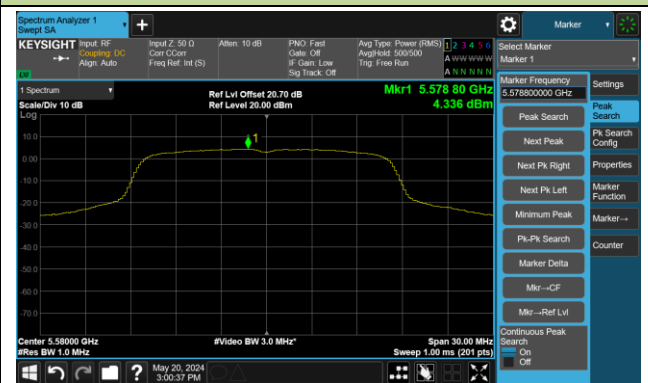

802.11a Power Spectral Density

Channel 140 (5700MHz)

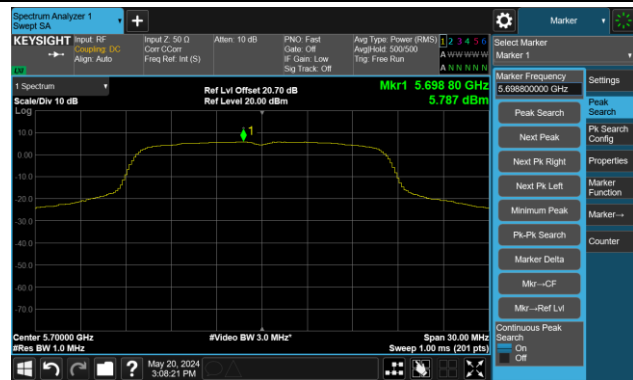

Channel 144(5720MHz)

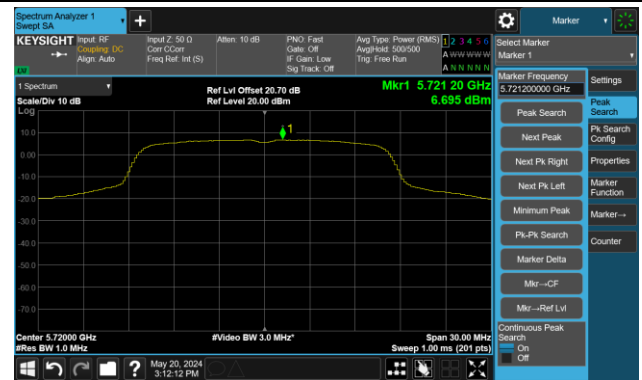

Channel 149 (5745MHz)



Channel 157 (5785MHz)



Channel 165 (5825MHz)

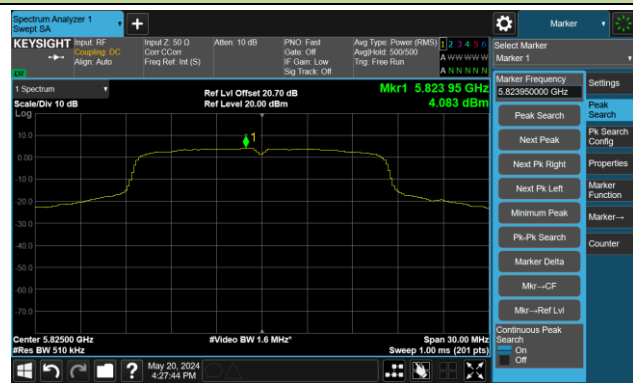

802.11ac-VHT20 Power Spectral Density

Channel 36 (5180MHz)

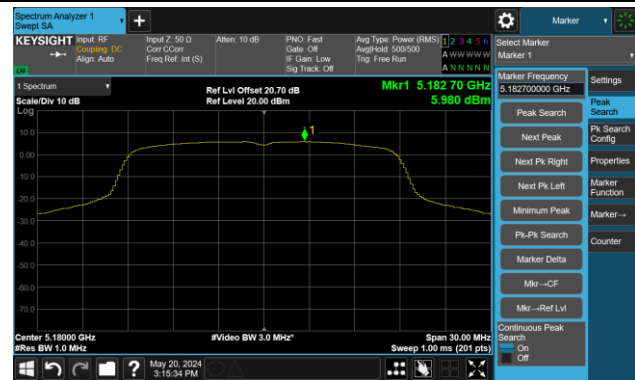

Channel 44 (5220MHz)



Channel 48 (5240MHz)

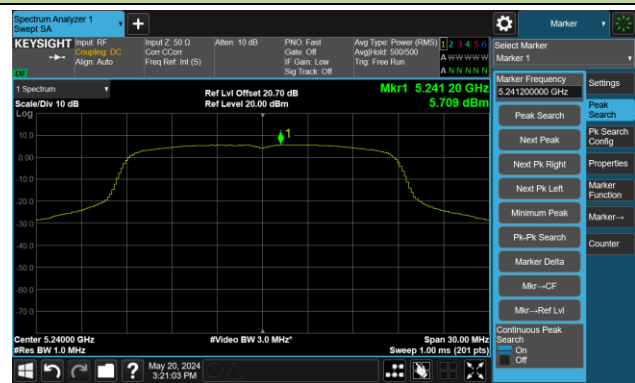

Channel 52 (5260MHz)

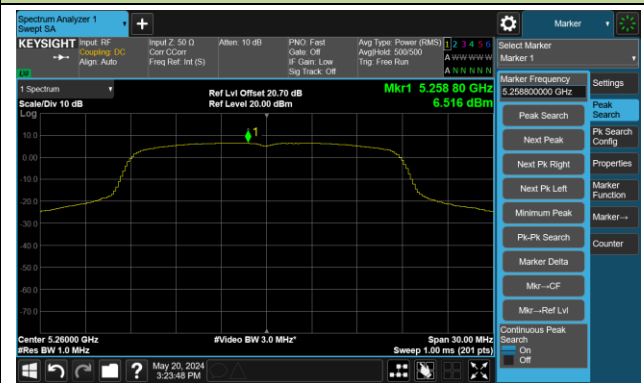

Channel 60 (5300MHz)

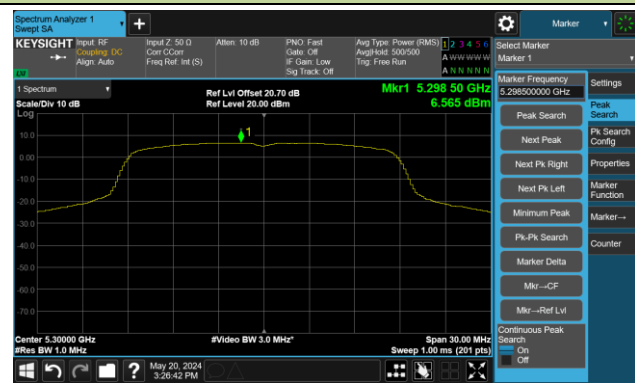

Channel 64 (5320MHz)

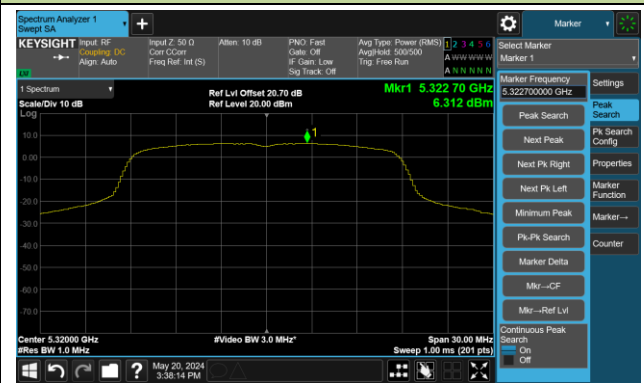

Channel 100 (5500MHz)

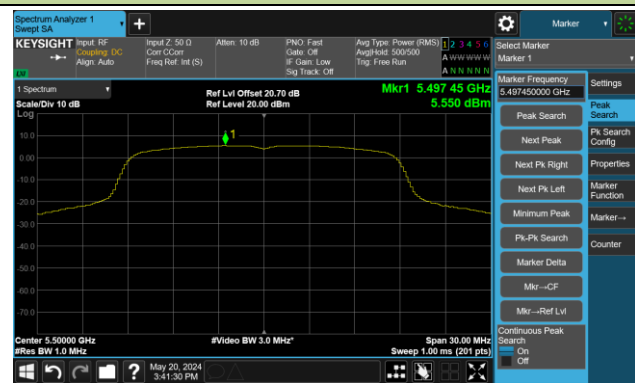

Channel 116 (5580MHz)

