



# SERVICE MANUAL

e.Sense

**e.Sense**

## Table of Content

i) Notice .....	1
ii) Safety Information .....	2
iii) Safety Regulations .....	2
<b>1. General.....</b>	<b>4</b>
1.1 Model Specification .....	4
1.2 Operating Specification .....	4
<b>2. Dimension.....</b>	<b>5</b>
<b>3. e.Sense Setup Diagram &amp; Spec Setting .....</b>	<b>6</b>
3.1 Overall Layout and Label design.....	6
3.3 Button Cell Specifications.....	6
3.4 ESL Attachment (Refer to ESL Attachment Catalogue).....	7
3.5 Product Handling of Info Tag.....	7
<b>4. Revision Records.....</b>	<b>8</b>

## **DIGI®**

The material contained in this document is proprietary and for information only and is subject to change without notice. Teraoka Weigh-System assumes no responsibility for any errors or damages arising from misinterpretation of any procedure.

Screen displays, operating procedures and supporting features might vary with different software version releases.

This document shall not be reproduced whether in part or whole without the written consent from Teraoka Weigh-System Pte Ltd.

**DIGI SINGAPORE PTE. LTD.  
4, Leng Kee Road  
#06-01 SIS Building  
Singapore 159088**

## ii) Safety Information

The operator of the equipment shall comply with the safety and warning indications and procedures outlined in this document. Teraoka Weigh-System Pte Ltd assumes no responsibility or liability for failure to comply with these requirements.

- Repair and servicing of product, shall only be carried out by trained and qualified personnel.

### Disclaimer:

Specifications are subject to change without notice. All dimensions shown are approximate. Please be aware that Teraoka has indicated that its hardware and software used in the product may require additional updates in the future as our product is continually under development. The need for such updates most likely applies to the Printer software.



### CAUTIONS:

**FOR PLUGGABLE EQUIPMENT, THAT THE SOCKET-OUTLET SHALL BE INSTALLED NEAR THE EQUIPMENT AND SHALL BE EASILY ACCESSIBLE.**

**POUR LE MATÉRIEL RACCORDÉ PAR PRISE DE COURANT, LE SOCLE DE PRISE DE COURANT DOIT ÊTRE  
INSALLÉ À PROXIMITÉ DU MATÉRIEL ET DOIT ÊTRE AISÉMENT ACCESSIBLE.**

**FOR CONTINUED PROTECTION AGAINST RISK OF FIRE, REPLACE ONLY WITH SAME TYPE AND RATING OF FUSE.**

**POUR NE PAS COMPROMETTRE LA PROTECTION CONTRE LES RISQUES D'INCENDIE,  
REPLACER PAR UN FUSIBLE DE MÊME TYPE ET DE MÊME CARACTÉRISTIQUES  
NOMINALES.**

**DANGER OF EXPLOSION IF BATTERY IS INCORRECTLY REPLACED. REPLACE ONLY WITH THE SAME OR EQUIVALENT TYPE RECOMMENDED BY THE MANUFACTURER. DISCARD USED BATTERIES ACCORDING TO THE MANUFACTURER'S INSTRUCTIONS**

**IL Y A DANGER D'EXPLOSION S'IL Y A REMPLACEMENT INCORRECT DE LA BATTERIE.  
REPLACER UNIQUEMENT AVEC UNE BATTERIE DU MÊME TYPE OU D'UN TYPE  
RECOMMANDÉ PAR LE CONSTRUCTEUR. METTRE AU RÉBUT LES BATTERIES USAGÉES  
CONFORMÉMENT AUX INSTRUCTIONS DU FABRICANT.**

## iii) Safety Regulations



### Federal Communication Commission Interference Statement

This equipment has been tested and found to comply with the limits for a Class B digital device, pursuant to Part 15 of the FCC Rules. These limits are designed to provide reasonable protection against harmful interference in a residential installation. This equipment generates, uses and can radiate radio frequency energy and, if not installed and used in accordance with the instructions, may cause harmful interference to radio communications. However, there is no guarantee that interference will not occur in a particular installation. If this equipment does cause harmful interference to radio or television reception, which can be determined by turning the equipment off and on, the user is encouraged to try to correct the interference by one of the following measures:

- Reorient or relocate the receiving antenna.
- Increase the separation between the equipment and receiver.

- Connect the equipment into an outlet on a circuit different from that to which the receiver is connected.
- Consult the dealer or an experienced radio/TV technician for help.

FCC Caution: Any changes or modifications not expressly approved by the party responsible for compliance could void the user's authority to operate this equipment.

This device complies with Part 15 of the FCC Rules. Operation is subject to the following two conditions: (1) This device may not cause harmful interference, and (2) this device must accept any interference received, including interference that may cause undesired operation.

**IDA Compliance Statement: (Singapore)**

This equipment registered to comply with IDA (Info-Communications Development Authority of Singapore) Standard under Dealer's Class License.

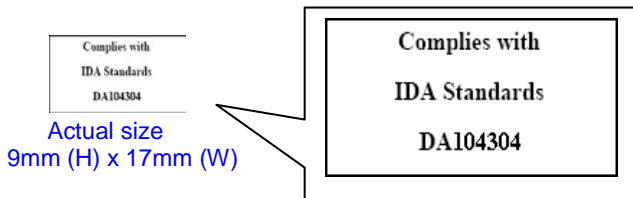

**Industry Canada statement:**

This device complies with RSS-210 of the Industry Canada Rules. Operation is subject to the following two conditions:

- (1) This device may not cause harmful interference, and
- (2) This device must accept any interference received, including interference that may cause undesired operation.

Ce dispositif est conforme à la norme CNR-210 d'Industrie Canada applicable aux appareils radio exempts de licence. Son fonctionnement est sujet aux deux conditions suivantes:

- (1) le dispositif ne doit pas produire de brouillage préjudiciable, et
- (2) ce dispositif doit accepter tout brouillage reçu, y compris un brouillage susceptible de provoquer un fonctionnement indésirable.

**IMPORTANT NOTE:**

Radiation Exposure Statement:

This equipment complies with IC radiation exposure limits set forth for an uncontrolled environment. End users must follow the specific operating instructions for satisfying RF exposure compliance. To maintain compliance with IC RF exposure compliance requirements, please follow operation instruction as documented in this manual.

Cet équipement est conforme avec l'exposition aux radiations IC définies pour un environnement non contrôlé. Les utilisateurs finaux doivent suivre les instructions de fonctionnement spécifiques pour satisfaire la conformité aux expositions RF. Pour respecter les exigences de conformité d'exposition RF IC, s'il vous plaît suivez les instructions d'utilisation documenté dans ce manuel.

**For Taiwan 警語:**

經型式認證合格之低功率射頻電機，非經許可，公司、商號或使用者均不得擅自變更頻率、加大功率或變更原設計之特性及功能。

低功率射頻電機之使用不得影響飛航安全及干擾合法通信；經發現有干擾現象時，應立即停用，並改善至無干擾時方得繼續使用。前項合法通信，指依電信法規定作業之無線電通信。低功率射頻電機須忍受合法通信或工業、科學及醫療用電波輻射性電機設備之干擾

## 1. General

### 1.1 Model Specification

<b>Model</b>	:	e.Sense
<b>Dimensions (in mm)</b>	:	e.Sense - 30.4 (D) X 11.5 (H)
<b>Weight</b>	:	12g approx.
<b>Power Source</b>	:	DC Cell Button Battery 3.0V X 1PCS
<b>IP Rating</b>	:	IP55
<b>Battery Specification</b>	:	Type - CR2450 (Cell Button Battery) Nominal Voltage - 3.0V Life Time - 5 years (2 triggers/day) Weight - 10g approx.

### 1.2 Operating Specification

<b>Power Source</b>	:	External	:	NA
	:	Internal	:	CR2450 x 1 pcs (Cell Button Battery)
<b>Operating Temperature</b>	:	0°C to +40°C		
<b>Humidity</b>	:	85% Max. Non-condensing		

## 2. Dimension

### e.Sense

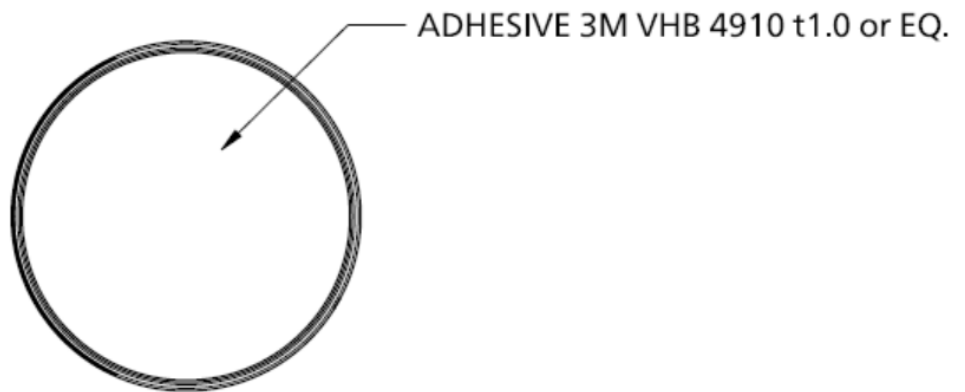
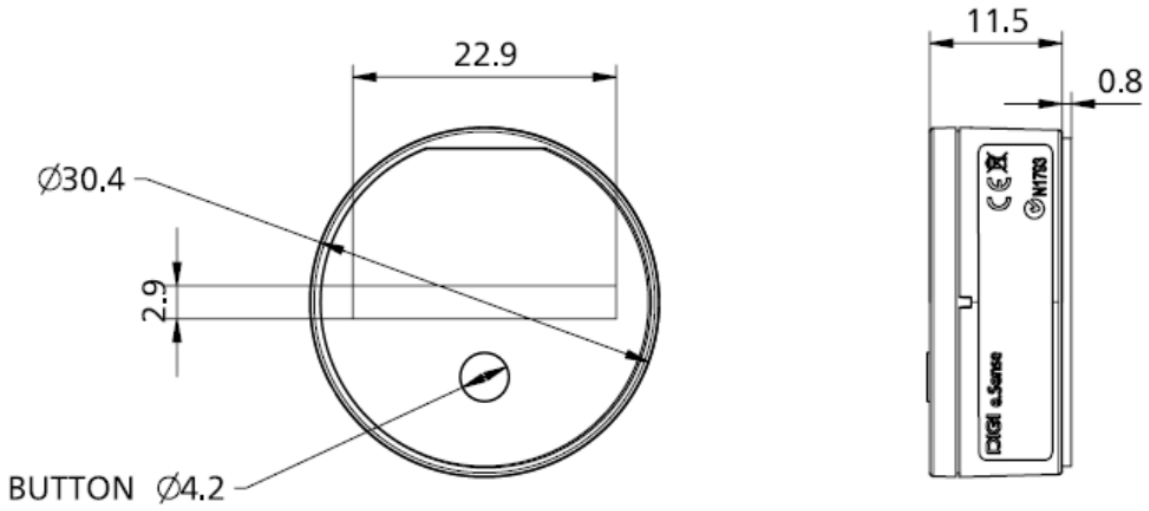

3. e.Sense Setup Diagram & Spec Setting

3.1 Overall Layout and Label design

e.Sense



Front View



Side View

Nameplate (e.Sense)



3.3 Button Cell Specifications

**CR2450**

■ Dimensions(mm)

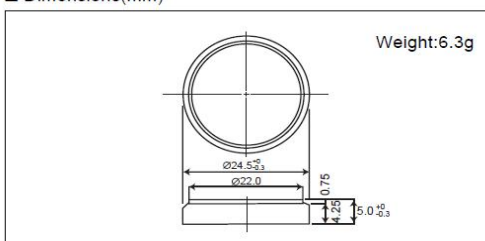

■ Specification

Nominal voltage (V)	3
Nominal capacity (mAh)	620
Continuous standard load (mA)	0.2
Operating temperature (C)	-30 ~ +60



### 3.4 ESL Attachment (Refer to ESL Attachment Catalogue)

For all information about the ESL Various Attachment type, function, installation etc. Please refer to ESL Attachment Catalogue

<http://www.digiesl.com.tw/digiesl/sys4.asp>

<http://www.teraoka.com.tw/digi/article.aspx?id=77>

### 3.5 Product Handling of Info Tag

Handle product with care. Do not expose product to corrosive chemical solution, any organic solvent acidic or alkaline. If cleaning is required, wash only water or mild soap solution.

Do not attempt to disassemble, apply force or heavy load to the product. No user serviceable parts inside.

