

DFS TEST REPORT

of

FCC PART 15 SUBPART E AND CANADA RSS-210

New Application; Class I PC; Class II PC

Product : IEEE 802.11a/b/g/n 2x2 Wireless LAN USB Client
Brand: Teraoka
Model: AP-3001g
Model Difference: N/A
FCC ID: SUFAP3001G
IC: 5633A-AP3001G
FCC Rule Part: §15.407, NII
IC Rule Part: RSS-210 issue 8:2010, Annex 9
Applicant: Teraoka Weigh-System Pte Ltd.
Address: 4 Leng Kee Rd, #05-03/04/05&11, SIS Building, Singapore

Test Performed by:

International Standards Laboratory

<Lung-Tan LAB>

*Site Registration No.

BSMI: SL2-IN-E-0013; MRA TW1036; TAF: 0997; IC: IC4067B-3;

*Address:

No. 120, Lane 180, San Ho Tsuen, Hsin Ho Rd.

Lung-Tan Hsiang, Tao Yuan County 325, Taiwan

*Tel : 886-3-407-1718; Fax: 886-3-407-1738

Report No.: **ISL-13LR112FE**

Issue Date : **2013/07/05**

Test results given in this report apply only to the specific sample(s) tested and are traceable to national or international standard through calibration of the equipment and evaluating measurement uncertainty herein.

This report **MUST** not be used to claim product endorsement by TAF, NVLAP or any agency of the Government.

This test report shall not be reproduced except in full, without the written approval of International Standards Laboratory.



VERIFICATION OF COMPLIANCE

Applicant: Teraoka Weigh-System Pte Ltd.
Product Description: IEEE 802.11a/b/g/n 2x2 Wireless LAN USB Client
Brand Name: Teraoka
Model No.: AP-3001g
Model Difference: N/A
FCC ID: SUFAP3001G
IC: 5633A-AP3001G
FCC Rule Part: §15.407
IC Rule Part: RSS-210 issue 8:2010, Annex 9
Date of test: 2013/06/25~ 2013/06/30
Date of EUT Received: 2013/06/24

We hereby certify that:

All the tests in this report have been performed and recorded in accordance with the standards described above and performed by an independent electromagnetic compatibility consultant, International Standards Laboratory.

The test results contained in this report accurately represent the measurements of the characteristics and the energy generated by sample equipment under test at the time of the test. The sample equipment tested as described in this report is in compliance with the limits of above standards.

Test By:



Date:

2013/07/05

Dion Chang / Engineer

Prepared By:



Date:

2013/07/05

Eva Kao / Technical Supervisor

Approved By:



Date:

2013/07/05

Vincent Su / Technical Manager

Version

Version No.	Date	Description
00	2013/07/05	Initial creation of document

Table of Contents

1. GENERAL INFORMATION	5
1.1. Product Description	5
1.2. Related Submittal(s) / Grant (s)	7
1.3. Test Methodology	7
1.4. Test Facility	7
1.5. Special Accessories	7
1.6. Equipment Modifications	7
2. SUMMARY OF TEST RESULT	8
3. TPC and DFS MEASUREMENT	9
3.1 TPC: Standard Applicable	9
3.2 DFS: Standard Applicable	9
3.3 Test Equipment Used:	15
3.4 Test results	16
APPENDIX 1 PHOTOGRAPHS OF SET UP	25
APPENDIX 2 PHOTOGRAPHS OF EUT	27

1. GENERAL INFORMATION

1.1. Product Description

General:

Product Name	IEEE 802.11a/b/g/n 2x2 Wireless LAN USB Client
Brand Name	Teraoka
Model Name	AP-3001g
Model Difference	N/A
Power Supply	5Vdc from USB of host PC
Hardware Version:	N/A
Software Version:	N/A
Adhoc Mode	No
DFS Mode	Client(without radar detection)
TPC	No

WLAN: 1TX/1RX

Wi-Fi	Frequency Range (MHz)	Channels	Modulation Technology
802.11b	2412 – 2462(DTS)	11	DSSS
802.11g	2412 – 2462(DTS)	11	DSSS/OFDM
802.11n	HT20 2412 – 2462(DTS)	11	OFDM
802.11a	5180 – 5320(NII)	8	OFDM
	5500 – 5700(NII)	8	
	5745 – 5825(DTS)	5	
802.11n	HT20 5180 – 5320(NII)	8	OFDM
	HT20 5500 – 5700(NII)	8	
	HT20 5745 – 5825(DTS)	5	
Modulation type		CCK, DQPSK, DBPSK for DSSS 64QAM, 16QAM, QPSK, BPSK for OFDM	
Antenna Designation:		PIFA Antenna 2412 – 2462MHz: -2.07dBi 5180 – 5320MHz: -0.03dBi 5500 – 5700MHz: 0.25dBi 5745 – 5825MHz: 0.7dBi	

The EUT is compliance with IEEE 802.11 a/b/g/n Standard.

This report applies for frequency bands 5250 MHz – 5350 MHz and 5470MHz – 5725MHz DFS test.

1.2. Related Submittal(s) / Grant (s)

This submittal(s) (test report) is intended for **FCC ID: SUFAP3001G** filing to comply with Section 15.407 of the FCC Part 15, Subpart E Rules and **IC: 5633A-AP3001G** filing to comply with Industry Canada RSS-210 issue 8: 2010 Annex 9. The composite system (digital device) is compliance with Subpart B is authorized under a DoC procedure.

1.3. Test Methodology

Both conducted and radiated testing were performed according to the procedures in ANSI C63.4 (2003) and RSS-Gen: 2010. Radiated testing was performed at an antenna to EUT distance 3 meters. Radiated testing was performed at an antenna to EUT distance 3 meters.

KDB Number: 848637

KDB Number: 905462

1.4. Test Facility

The measurement facilities used to collect the 3m Radiated Emission and AC power line conducted data are located on the address of International Standards Laboratory <Lung-Tan LAB> No. 120, Lane 180, San Ho Tsuen, Hsin Ho Rd., Lung-Tan Hsiang, Tao Yuan County 325, Taiwan which are constructed and calibrated to meet the FCC requirements in documents ANSI C63.4: 2003. FCC Registration Number is: TW1036, Canada Registration Number: 4067B-3.

1.5. Special Accessories

Not available for this EUT intended for grant.

1.6. Equipment Modifications

Not available for this EUT intended for grant.

2. SUMMARY OF TEST RESULT

FCC Rules	Description Of Test	Result
§15.407(d) RSS 210 A9.3	TPC and DFS Measurement	Compliant

3. TPC and DFS MEASUREMENT

15.1 TPC: Standard Applicable

According to §15.407(h)(1), Transmit power control (TPC). U-NII devices operating in the 5.25-5.35 GHz band and the 5.47-5.725 GHz band shall employ a TPC mechanism. The U-NII device is required to have the capability to operate at least 6 dB below the mean EIRP value of 30 dBm. A TPC mechanism is not required for systems with an e.i.r.p. of less than 500 mW.

According to RSS 210 A9.2 (3), The maximum conducted output power shall not exceed 250mW or $11 + 10 \log_{10} B$, dBm, whichever power is less. The power spectral density shall not exceed 11dBm in any 1.0 MHz band. The maximum e.i.r.p. shall not exceed 1.0 W or $17 + 10 \log_{10} B$, dBm, whichever power is less. B is the 99% emission bandwidth in MHz. Note that devices with a maximum e.i.r.p. greater than 500mW shall implement TPC in order to have the capability to operate at least 6 dB below the maximum permitted e.i.r.p. of 1 W.

15.1.1. Result: N/A, The output power is less than 500mW(27dBm). Refer to FCC 15.407/RSS 210 test report.

15.2 DFS: Standard Applicable

According to §15.407(h)(2), Radar Detection Function of Dynamic Frequency Selection (DFS). U-NII devices operating in the 5.25-5.35 GHz and 5.47-5.725 GHz bands shall employ a DFS radar detection.

According to RSS 210 A9.3), Note: For the band 5600-5650 MHz, no operation is permitted. Until further notice, devices subject to this annex shall not be capable of transmitting in the band 5600-5650 MHz. This restriction is for the protection of Environment Canada weather radars operating in this band.

Devices operating in the bands 5250-5350 MHz, 5470-5600 MHz and 5650-5725 MHz band shall comply with the following:

(a) Devices shall employ a DFS radar detection mechanism to detect the presence of radar systems and to avoid co-channel operation with radar systems (see Note below). The minimum DFS radar signal detection threshold is -62dBm for devices with a maximum e.i.r.p. less than 200mW, and -64dBm for devices with a maximum e.i.r.p. of 200mW to 1 W. The detection threshold power is the received power, averaged over a 1-microsecond reference to a 0dBi antenna. The DFS process shall provide a uniform spreading of the loading over all the available channels.

Note: Test procedures for demonstrating compliance with the DFS radar detection requirements set out in this section are being evaluated by Industry Canada. As an interim measure, the Department will, until further notice, accept utilization of the DFS test procedures published by the U.S. Federal Communications Commission (FCC) 3 to demonstrate compliance with the requirements of this section.

(b) Operational requirements: the requirement for channel availability check time applies in the master operational mode. The requirement for channel move time applies in both the master and slave operational modes.

(i) In-service monitoring: an LE-LAN device should be able to monitor the operating channel to check that a co-channel radar has not moved or started operation within range of the LE-LAN device. During in-service monitoring, the LE-LAN radar detection function continuously searches for radar signals between normal LE-LAN transmissions.

(ii) Channel availability check time: the device shall check if there is a radar system already operating on the channel before it initiates a transmission on a channel and when it moves to a channel. The device may start using the channel if no radar signals with a power level greater than the interference threshold value specified in A9.3 (a) above is detected within 60 seconds.

(iii) Channel move time: after a radar's signal is detected, the device shall cease all transmissions on the operating channel within 10 seconds. Transmission during this period shall consist of normal traffic for a maximum of 200 ms after detection of the radar signal. Intermittent management and control signals may also be sent during the remaining time to facilitate vacating the operating channel.

(iv) Channel closing time: the maximum channel closing time is 260 ms.

(v) Non-occupancy period: a channel that has been flagged as containing a radar signal, either by a channel availability check or in-service monitoring, is subject to a 30-minute non-occupancy period where the channel cannot be used by the LE-LAN device. The non-occupancy period starts from the time that the radar signal is detected.

15.2.1. Limit

Table 1: Applicability of DFS requirements prior to use of a channel

Requirement	Operational Mode		
	Master	Client(without radar detection)	Client(with radar detection)
Non-occupancy Period	Yes	Not required	Yes
DFS Detection Threshold	Yes	Not required	Yes
Channel Availability Check Time	Yes	Not required	Not required
Uniform Spreading	Yes	Not required	Not required
U-NII Detection Bandwidth	Yes	Not required	Yes

Table 2: Applicability of DFS requirements during normal operation

Requirement	Operational Mode		
	Master	Client(without radar detection)	Client(with radar detection)
DFS Detection Threshold	Yes	Not required	Yes
Channel Closing Transmission Time	Yes	Yes	Yes
Channel Move Time	Yes	Yes	Yes
U-NII Detection Bandwidth	Yes	Not required	Yes

Refer to KDB Number: 848637

Refer to KDB Number: 905462 APPENDIX B COMPLIANCE MEASUREMENT PROCEDURES FOR UNLICENSED-NATIONAL INFORMATION INFRASTRUCTURE DEVICES OPERATING IN THE 5.25-5.35 GHz AND 5.47-5.725 GHz BANDS INCORPORATING DYNAMIC FREQUENCY SELECTION.

Table 3: Interference Threshold values, Master or Client incorporating In-Service Monitoring

Maximum Transmit Power	Value (see note)
≥ 200 milliwatt	-64 dBm
< 200 milliwatt	-62 dBm
Note 1: This is the level at the input of the receiver assuming a 0 dBi receive antenna Note 2: Throughout these test procedures an additional 1 dB has been added to the amplitude of the test transmission waveforms to account for variations in measurement equipment. This will ensure that the test signal is at or above the detection threshold level to trigger a DFS response.	

Table 4: DFS Response requirement values

Parameter	Value
<i>Non-occupancy period</i>	Minimum 30 minutes
<i>Channel Availability Check Time</i>	60 seconds
<i>Channel Move Time</i>	10 seconds See Note 1.
<i>Channel Closing Transmission Time</i>	200 milliseconds + an aggregate of 60 milliseconds over remaining 10 second period. See Notes 1 and 2.
<i>U-NII Detection Bandwidth</i>	Minimum 80% of the U-NII 99% transmission power bandwidth. See Note 3.
<p>Note 1: The instant that the <i>Channel Move Time</i> and the <i>Channel Closing Transmission Time</i> begins is as follows:</p> <ul style="list-style-type: none"> • For the Short Pulse Radar Test Signals this instant is the end of the <i>Burst</i>. • For the Frequency Hopping radar Test Signal, this instant is the end of the last radar <i>Burst</i> generated. • For the Long Pulse Radar Test Signal this instant is the end of the 12 second period defining the <i>Radar Waveform</i>. <p>Note 2: The <i>Channel Closing Transmission Time</i> is comprised of 200 milliseconds starting at the beginning of the <i>Channel Move Time</i> plus any additional intermittent control signals required to facilitate a <i>Channel</i> move (an aggregate of 60 milliseconds) during the remainder of the 10 second period. The aggregate duration of control signals will not count quiet periods in between transmissions.</p> <p>Note 3: During the <i>U-NII Detection Bandwidth</i> detection test, radar type 1 is used and for each frequency step the minimum percentage of detection is 90 percent. Measurements are performed with no data traffic.</p>	

Table 5: Radar Test Waveforms

Short Pulse Radar

Radar Type	Pulse Width (μsec)	PRI (μsec)	Number of Pulses	Minimum Percentage of Successful Detection	Minimum Trials
1	1	1428	18	60%	30
2	1-5	150-230	23-29	60%	30
3	6-10	200-500	16-18	60%	30
4	11-20	200-500	12-16	60%	30
Aggregate (Radar Types 1-4)				80%	120

A minimum of 30 unique waveforms are required for each of the Short Pulse Radar Types 2 through 4. For Short Pulse Radar Type 1, the same waveform is used a minimum of 30 times. If more than 30 waveforms are used for Short Pulse Radar Types 2 through 4, then each additional waveform must also be unique and not repeated from the previous waveforms

Long Pulse Radar

Radar Type	Pulse Width (μsec)	Chirp Width (MHz)	PRI (μsec)	Number of Pulses per Burst	Number of Bursts	Minimum Percentage of Successful Detection	Minimum Trials
5	50-100	5-20	1000-2000	1-3	8-20	80%	30

The parameters for this waveform are randomly chosen. Thirty unique waveforms are required for the Long Pulse Radar Type waveforms. If more than 30 waveforms are used for the Long Pulse Radar Type waveforms, then each additional waveform must also be unique and not repeated from the previous waveforms.

Frequency Hopping Radar

Radar Type	Pulse Width (μsec)	PRI (μsec)	Pulses per Hop	Hopping Rate (kHz)	Hopping Sequence Length (msec)	Minimum Percentage of Successful Detection	Minimum Trials
6	1	333	9	.333	300	70%	30

For the Frequency Hopping Radar Type, the same *Burst* parameters are used for each waveform. The hopping sequence is different for each waveform and a 100-length segment is selected from the hopping sequence defined by the following algorithm: 3

The first frequency in a hopping sequence is selected randomly from the group of 475 integer frequencies from 5250 – 5724 MHz. Next, the frequency that was just chosen is removed from the group and a frequency is randomly selected from the remaining 474 frequencies in the group. This process continues until all 475 frequencies are chosen for the set. For selection of a random frequency, the frequencies remaining within the group are always treated as equally likely.

15.2.2. Test Setup

Setup for Master with injection at the Master

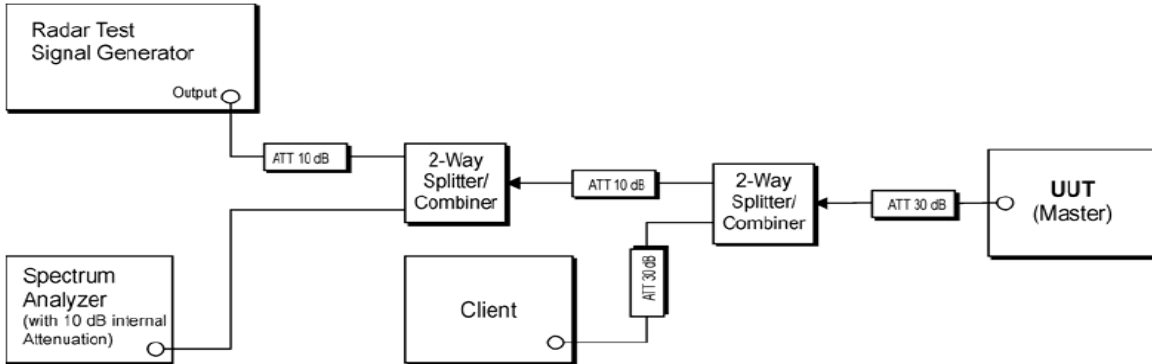

Setup for Client with injection at the Master(Used for DFS test)

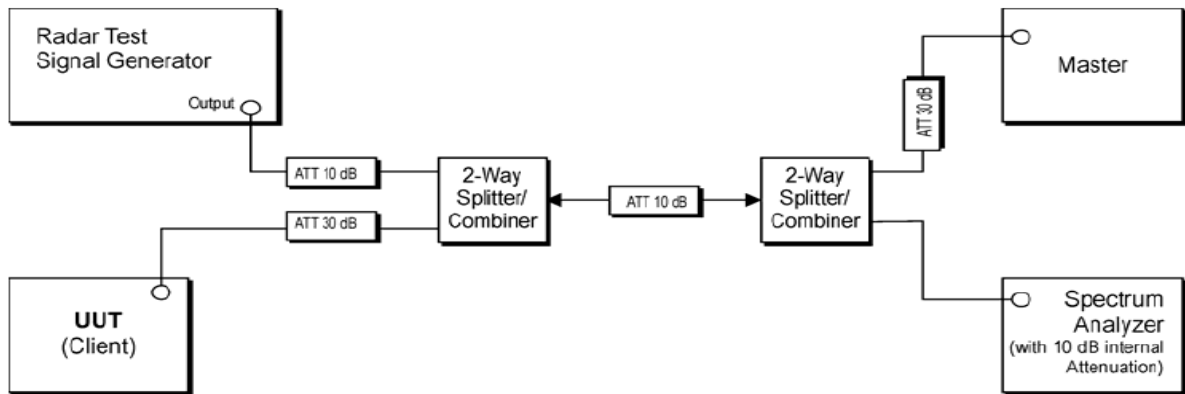

Setup for Client with injection at the Client

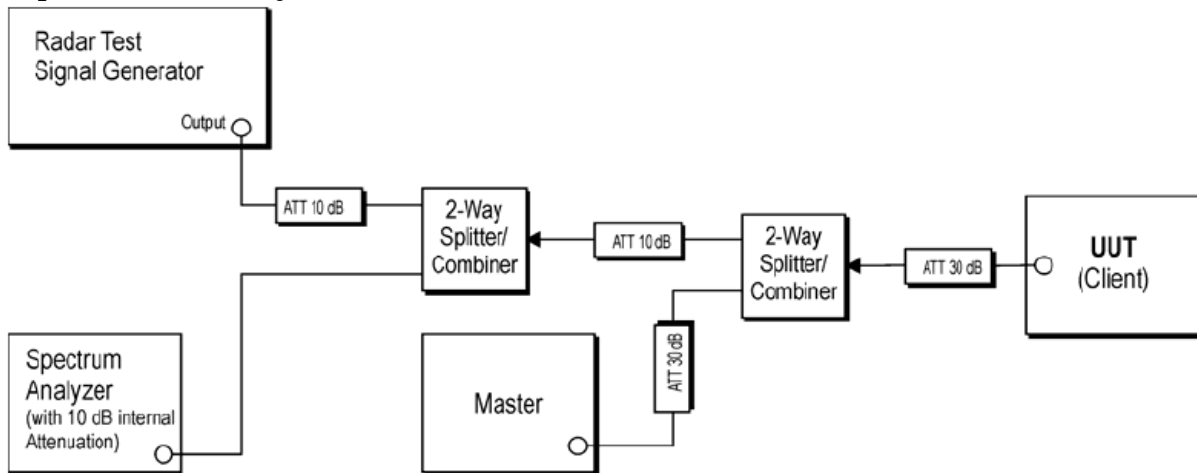

15.3 Test Equipment Used:

Conducted DFS Test Site					
EQUIPMENT TYPE	MFR	MODEL NUMBER	SERIAL NUMBER	LAST CAL.	CAL DUE.
Signal Generator	Agilent	E4438C	MY49071550	04/10/2013	04/09/2014
Spectrum analyzer	Agilent	N9030A	MY51360021	03/10/2013	03/09/2014
AP Router	Cisco	AIR-RM1252A G-A-K9	FTX1220905D	NA	NA
Splitter	Mini-Circuits	ZN2PD-63-S	UU97201111	NA	NA
Attenuator	Woken	Watt-65m3502	11051601	NA	NA
Software	Agilent	DFS TEST	NA	NA	NA
Cable	Draka	NA	NA	NA	NA

15.2.4. Description of EUT :

EUT operates over the 5250-5350MHz and 5470-5725MHz ranges and EUT is a slave device (client equipment) w/o radar detection and DFS capability.

The EUT utilizes the 802.11a architecture, with a nominal channel bandwidth of 20MHz WLAN traffic is generated by streaming the mpeg file from the master to slave in full monitor video mode using the media player.

The required interference threshold level is -64dBm, and the master device as employed for the applicable DFS test is CISCO router whose FCC ID= LDK102061

15.4 Test results

Applicability of DFS requirements prior to use of a channel

Requirement	Operational Mode: Client(without radar detection)	
	Test Result	Remark
Non-occupancy Period	Great than 30s Refer to next page for plots.	Pass
DFS Detection Threshold	N/A	N/A
Channel Availability Check Time	N/A	N/A
Uniform Spreading	N/A	N/A
U-NII Detection Bandwidth	N/A	N/A

Applicability of DFS requirements during normal operation

Requirement	Operational Mode: Client(without radar detection)	
	Test Result	Remark
DFS Detection Threshold	N/A	N/A
Channel Closing Transmission Time	Less than 200ms, Refer to next page for plots.	Pass
Channel Move Time	Less than 10s, Refer to next page for plots.	Pass
U-NII Detection Bandwidth	N/A	N/A

Input Level to Master AP= -64dBm

5250MHz ~ 5350MHz

Radar Type 1 Channel Move Time

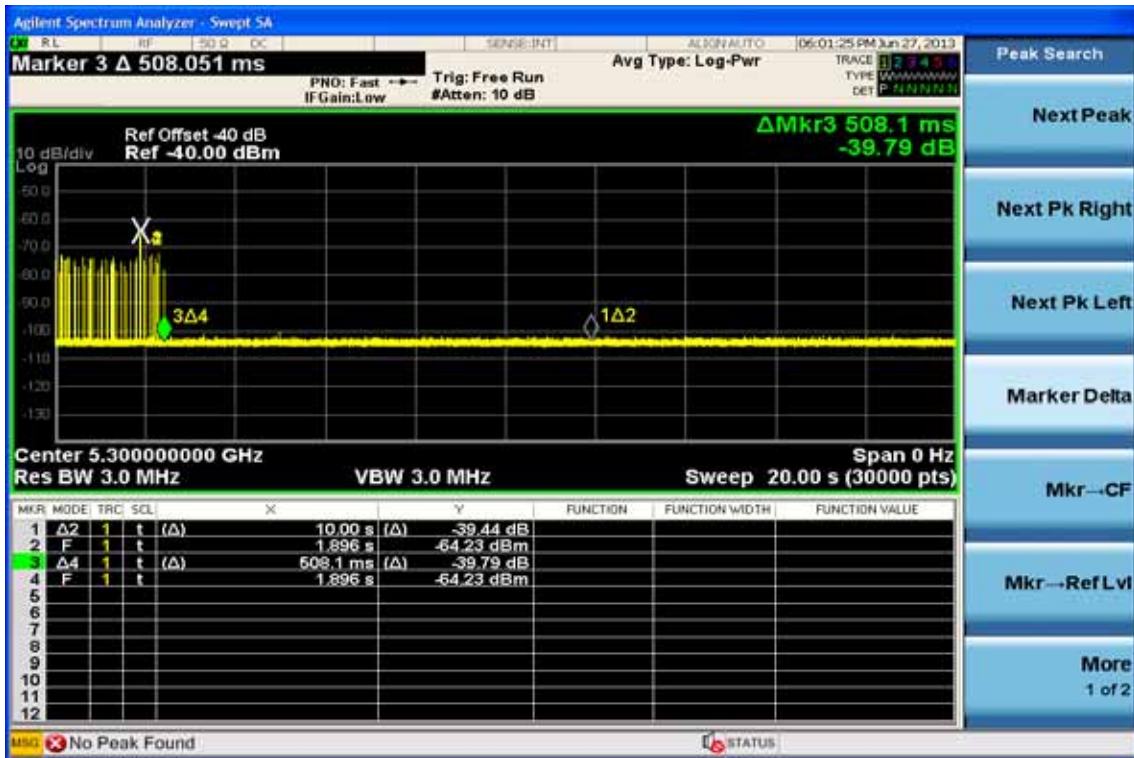

Radar Type 1 Channel Closing Transmission Time

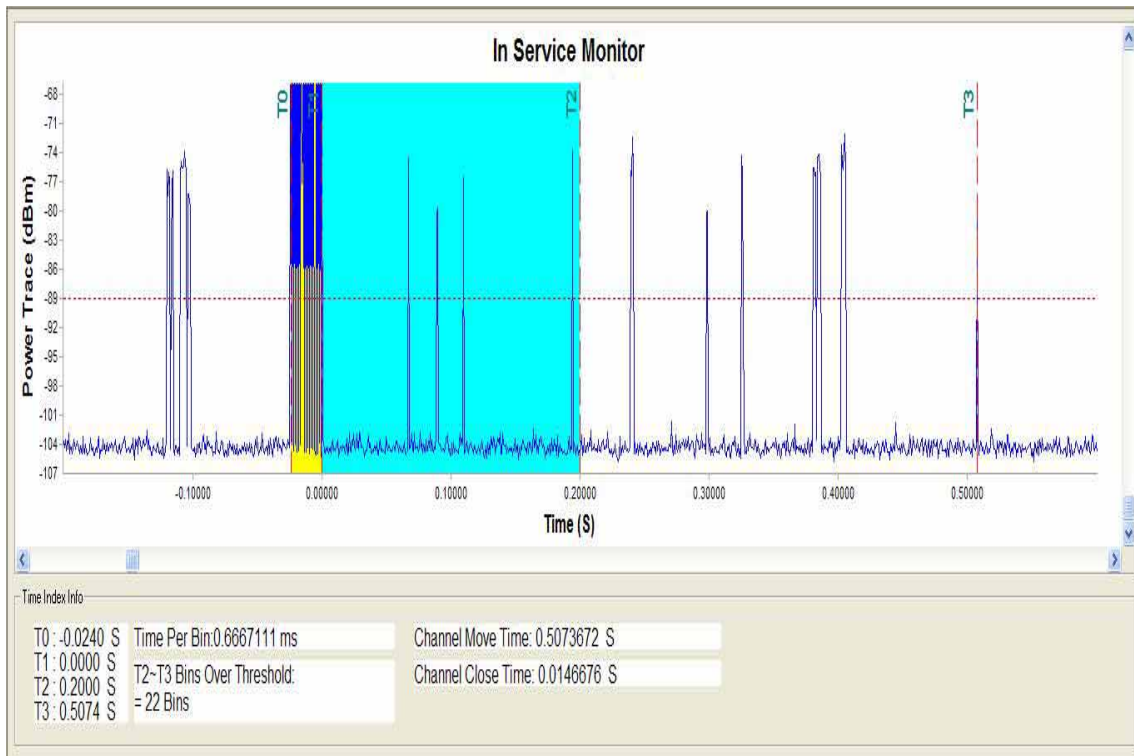

Non-occupancy Period

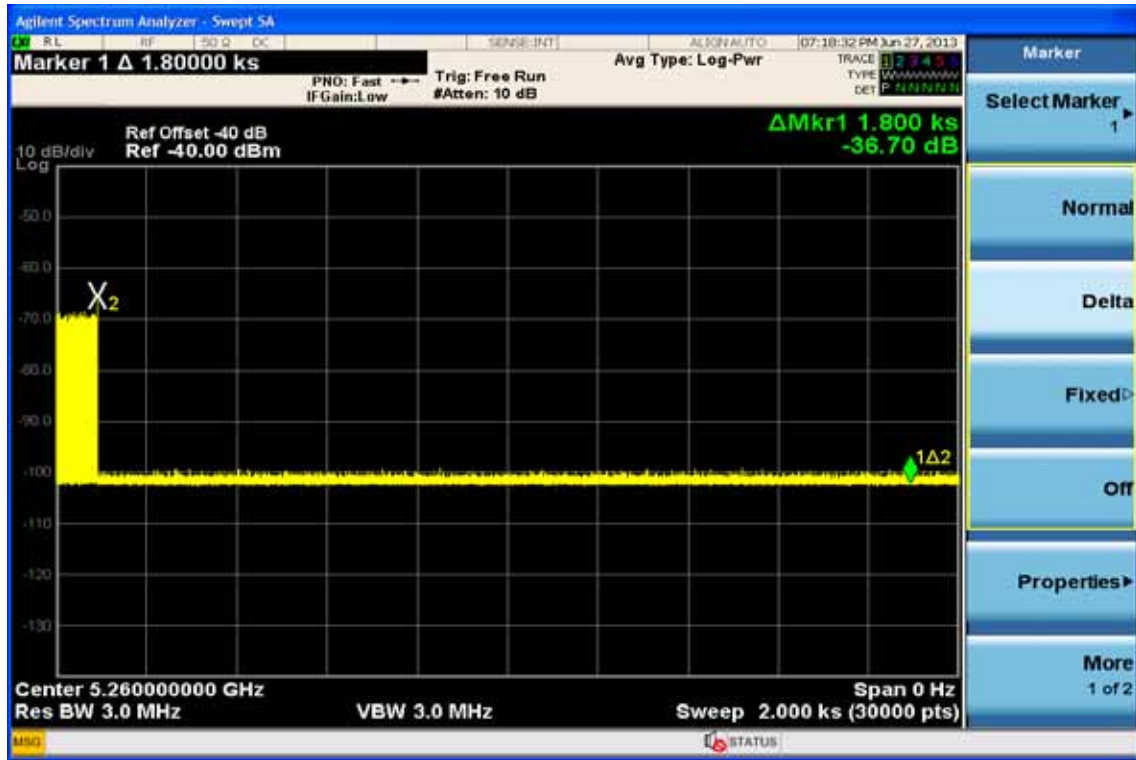

5500MHz ~ 5700MHz

Radar Type 1 Channel Move Time

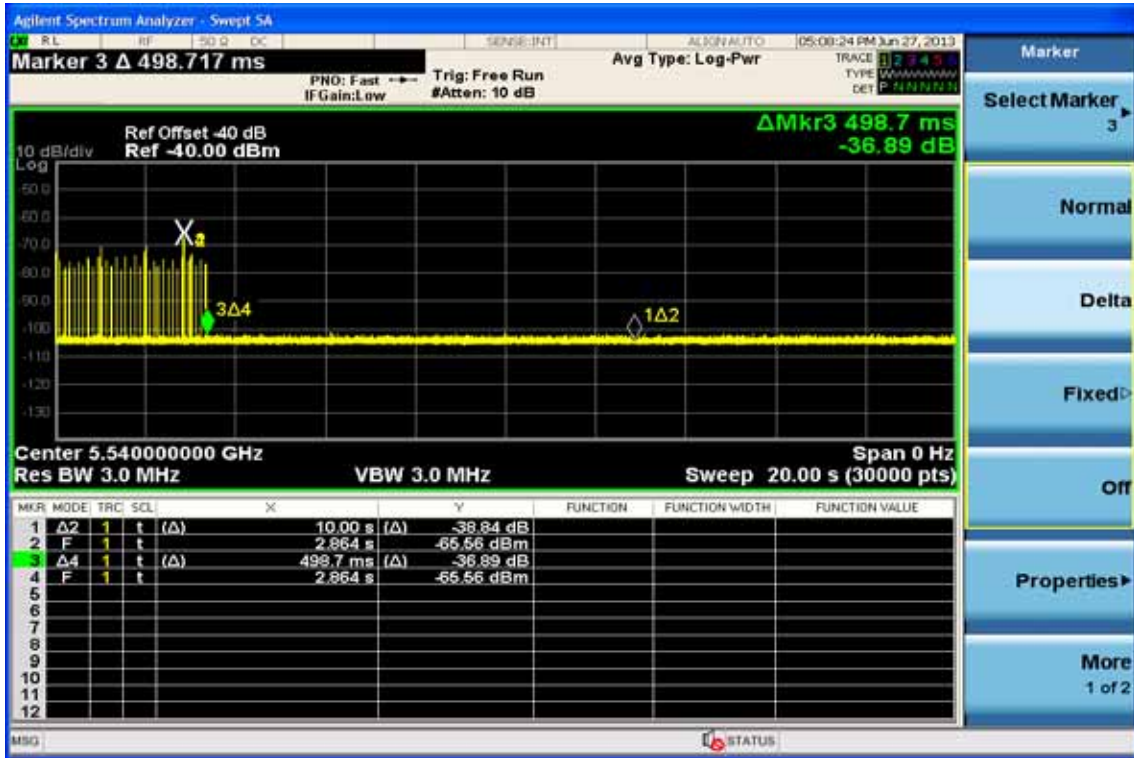

Radar Type 1 Channel Closing Transmission Time

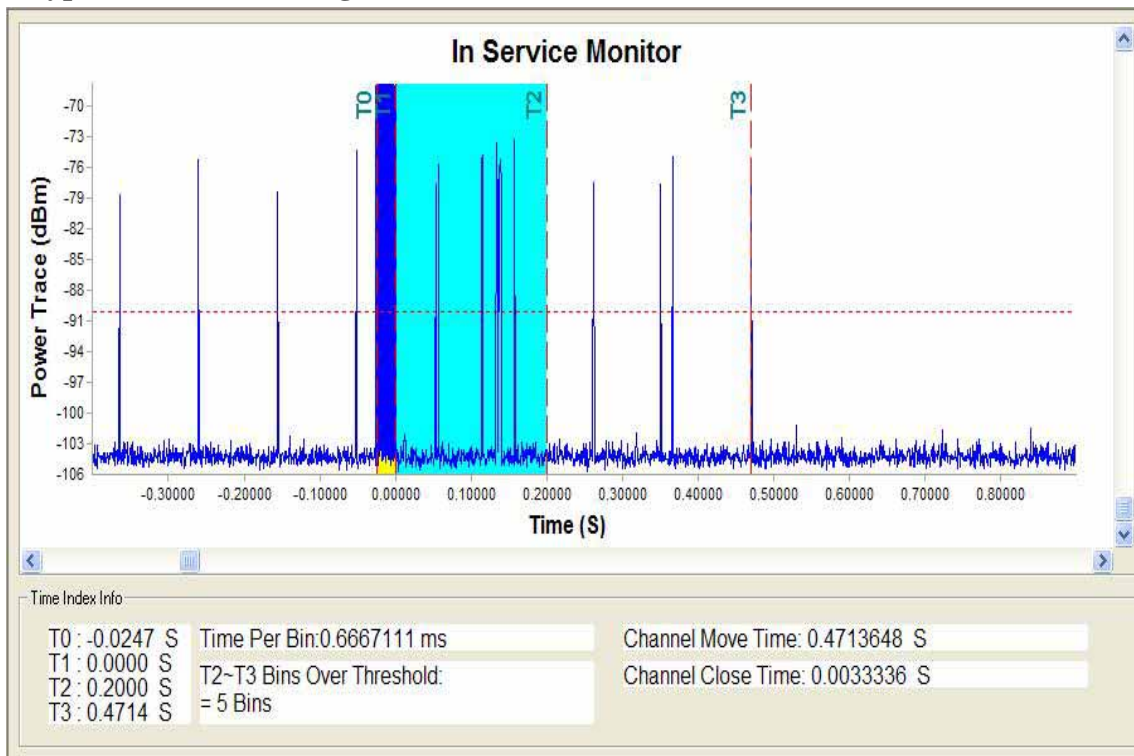

Non-occupancy Period



Radar type 3

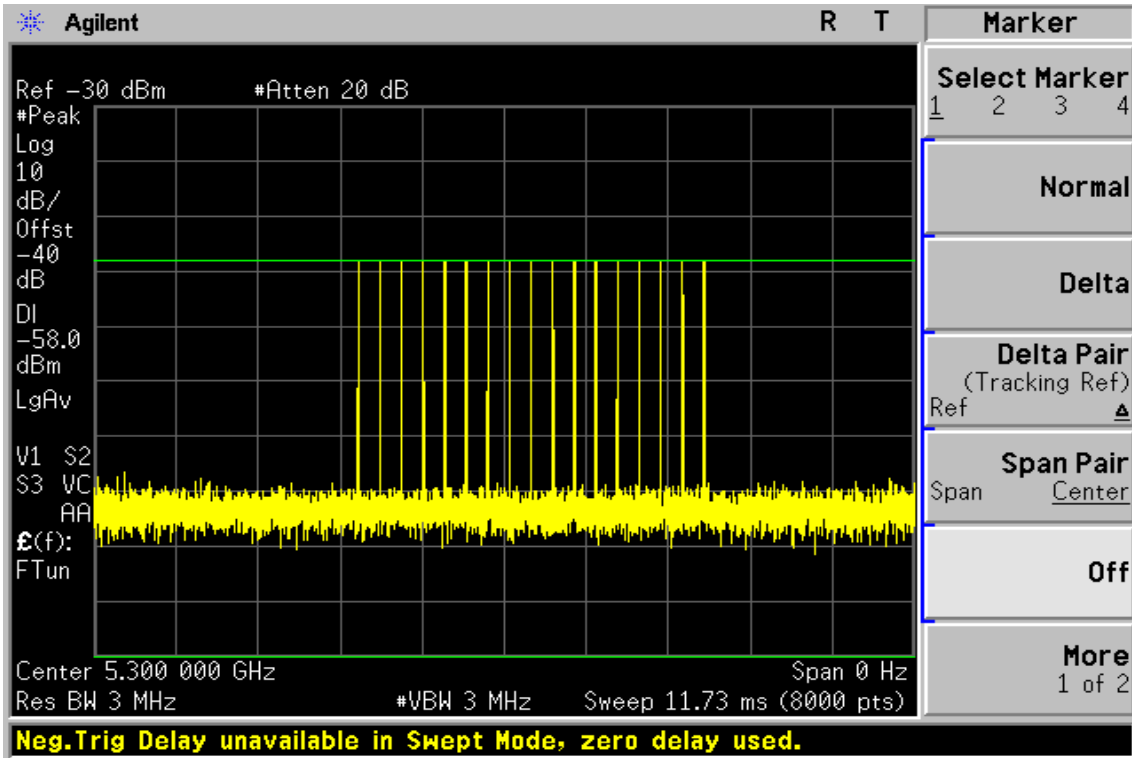

Radar type 4

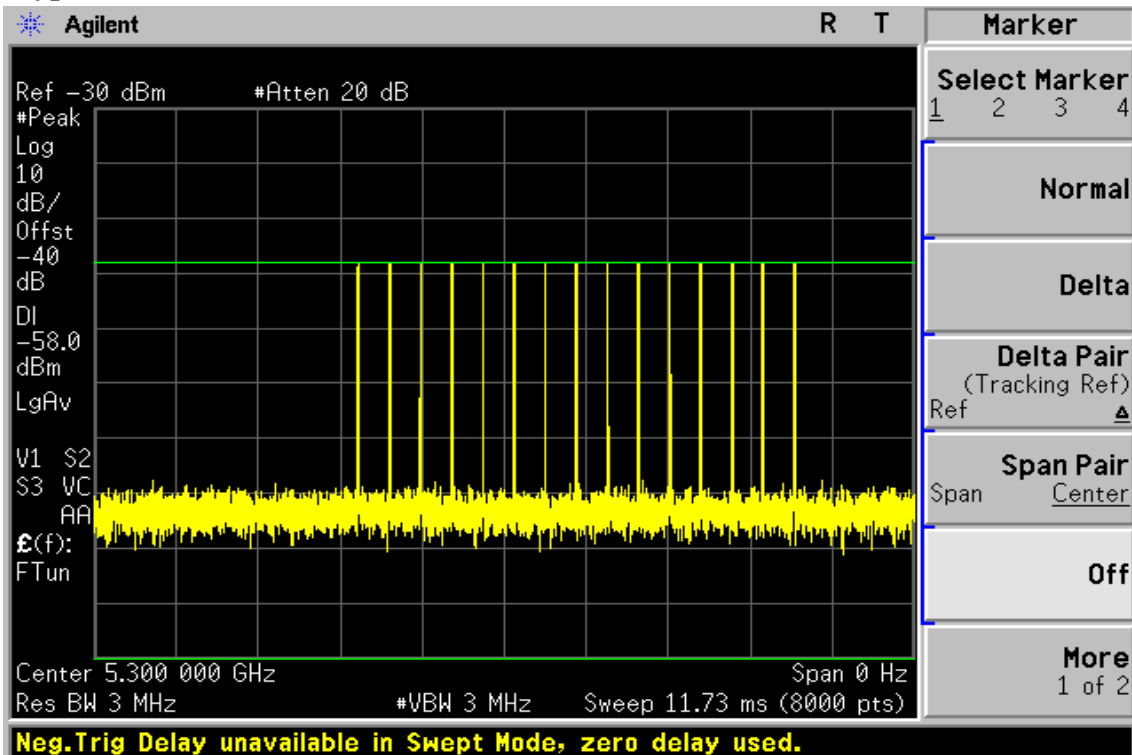

Radar type 5

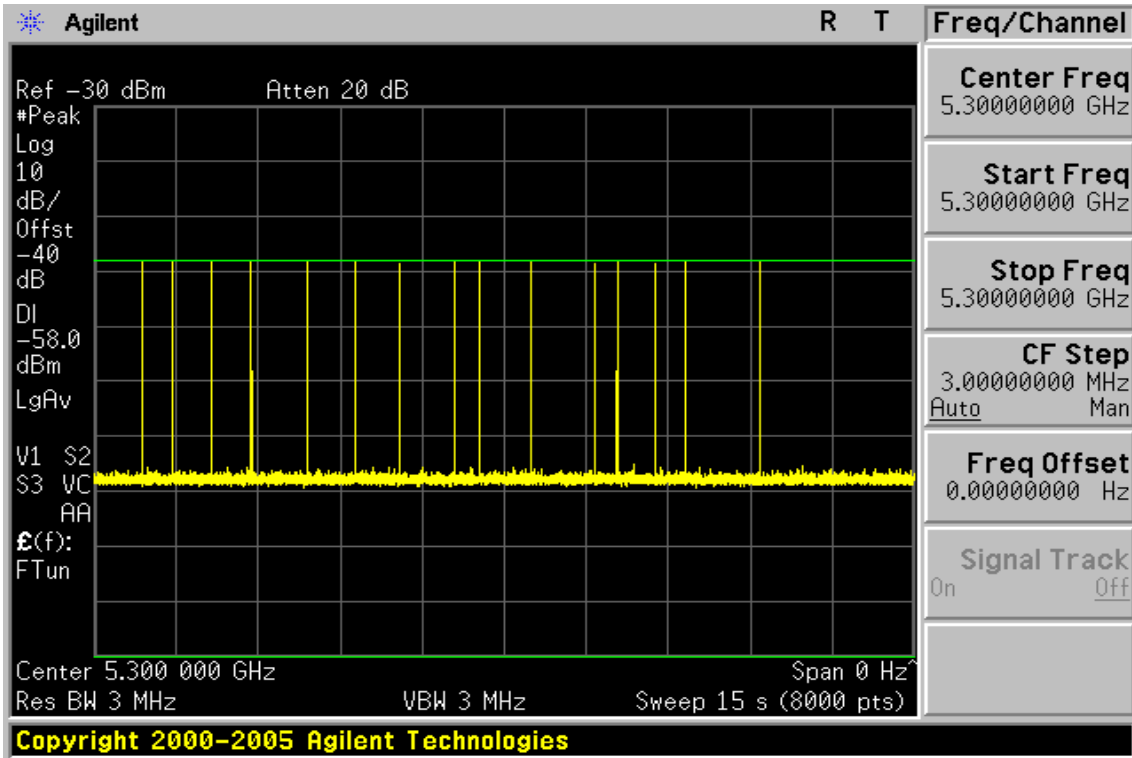

Radar type 6

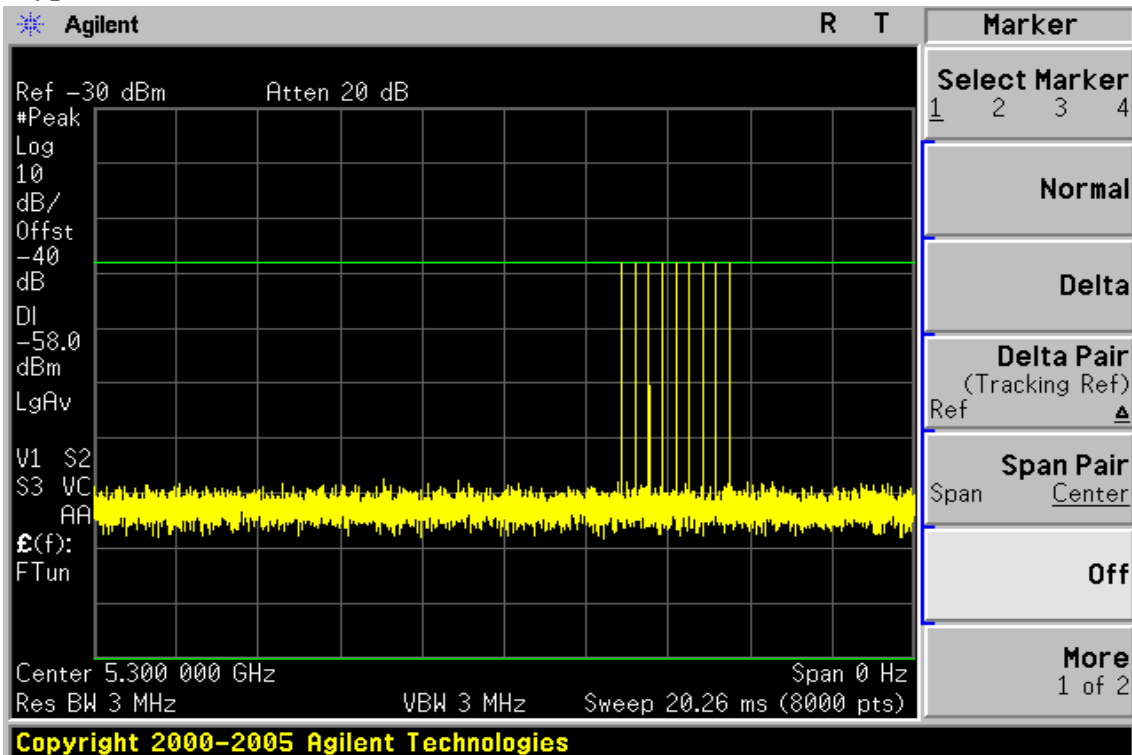

WLAN traffic

B2

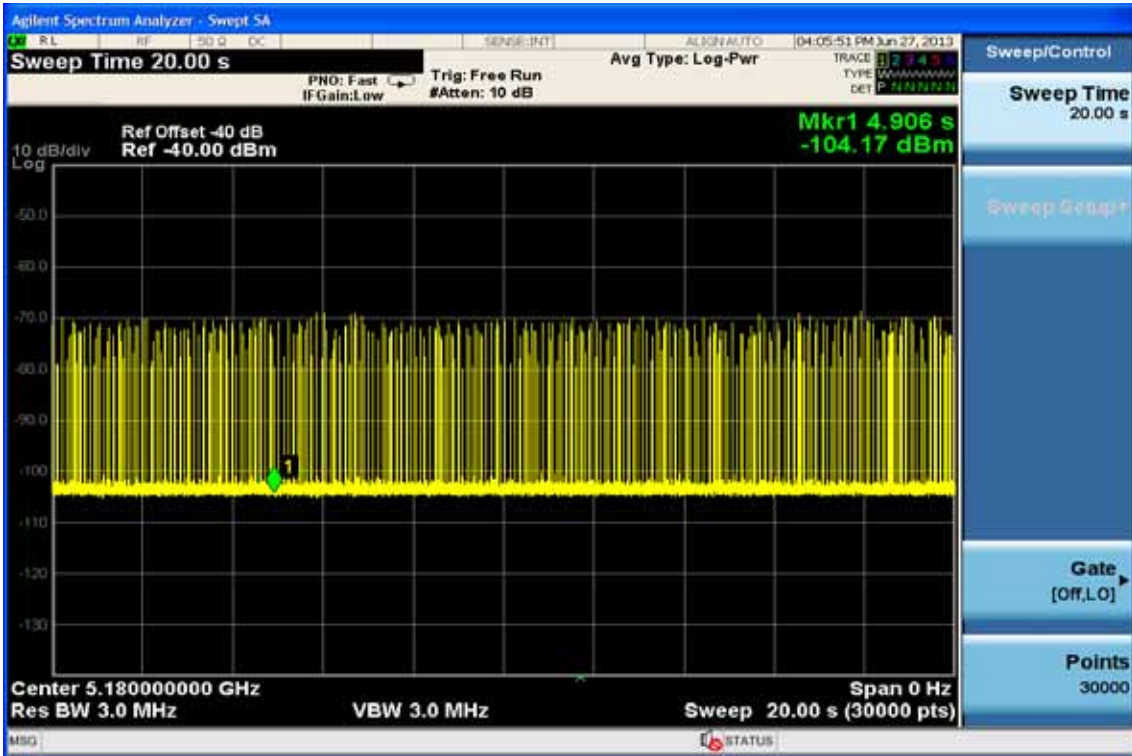

B3

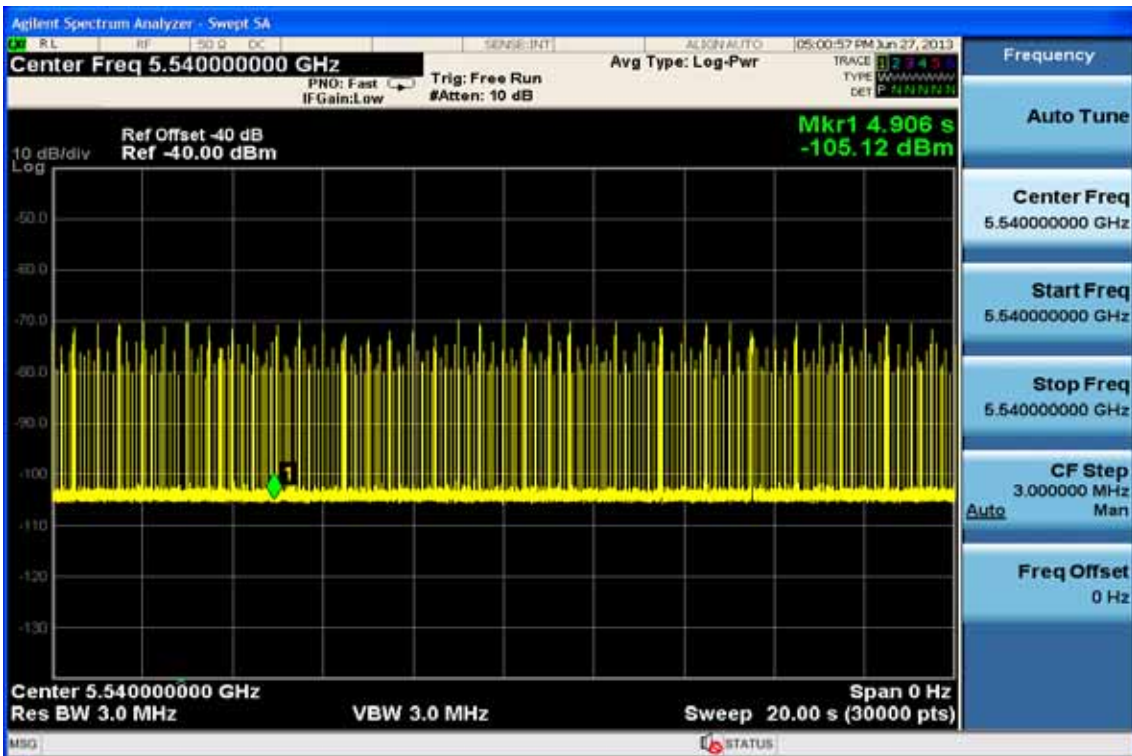

4. Maximum Permissible Exposure (MPE)

APPENDIX 1
PHOTOGRAPHS OF SET UP

DFS Setup Photos

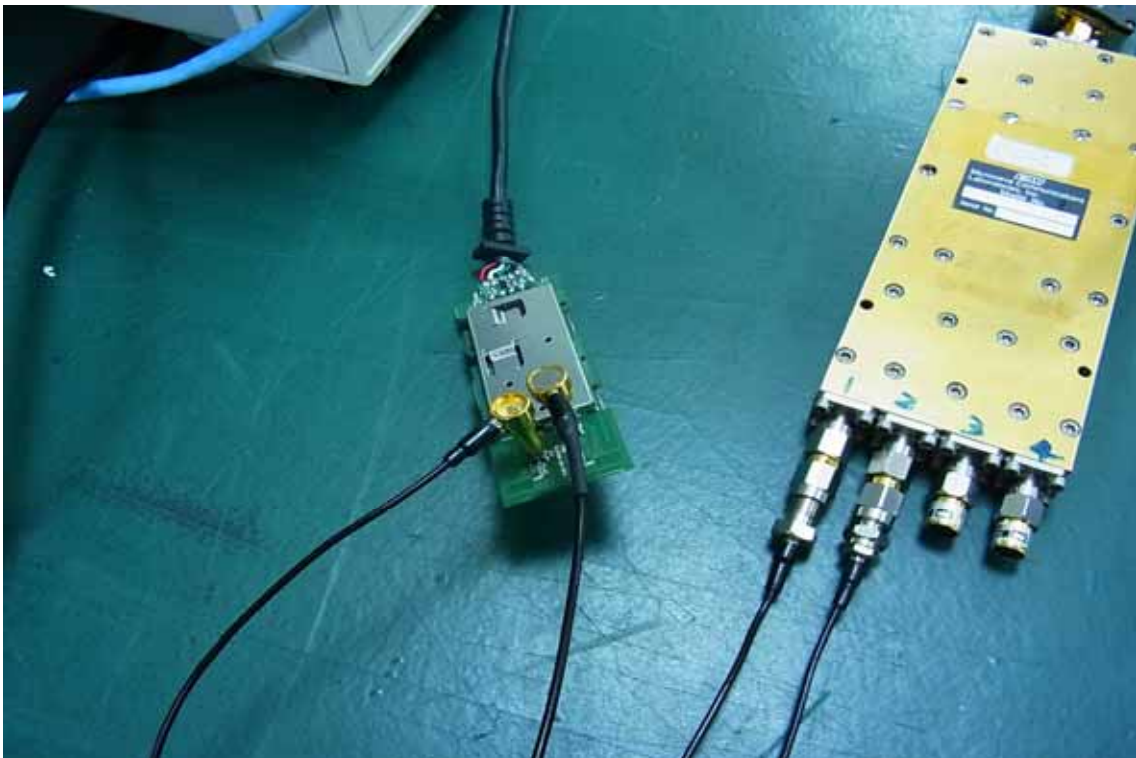

APPENDIX 2

PHOTOGRAPHS OF EUT

Refer to FCC 15.407/RSS210 test report

~ End of Report ~