



# **USER MANUAL**

**SOUNDCAST WIRELESS AUDIO SYSTEMS**

**KSC INDUSTRIES, INC.  
881 KUHN DRIVE, BUILDING 200  
CHULA VISTA, CA 91914**

## TABLE OF CONTENT

1. GENERAL DESCRIPTION.....		2
2. FEATURES .....		4
3. ELECTRICAL SPECIFICATIONS .....		5
3.1 OPERATING CONDITIONS – SOUNDCAST G2 TRANSMITTER.....		5
3.2 ABSOLUTE MAXIMUM RATINGS – SOUNDCAST G2 TRANSMITTER .....		5
3.3 OPERATING CONDITIONS – SOUNDCAST G2 RECEIVER.....		6
3.4 ABSOLUTE MAXIMUM RATINGS – SOUNDCAST G2 RECEIVER.....		6
3.5 OPERATING CONDITIONS – SOUNDCAST G2-ER TRANSMITTER.....		7
3.6 ABSOLUTE MAXIMUM RATINGS – SOUNDCAST G2-ER TRANSMITTER .....		7
3.7 OPERATING CONDITIONS – SOUNDCAST G2-ER RECEIVER.....		8
3.8 ABSOLUTE MAXIMUM RATINGS – SOUNDCAST G2-ER RECEIVER.....		9
4. AUDIO CHARACTERISTICS .....		10
5. RF CHARACTERISTICS .....		11
5.1 RF CHARACTERISTICS - SOUNDCAST G2 TRANSMITTER AND RECEIVER.....		13
5.2 RF CHARACTERISTICS - SOUNDCAST G2-ER TRANSMITTER AND RECEIVER....		13
6. PIN DESCRIPTION .....		14
6.1 PIN DESCRIPTION - SOUNDCAST G2 AND G2-ER TRANSMITTER .....		14
6.2 PIN DESCRIPTION - SOUNDCAST G2 AND G2-ER RECEIVER.....		15
7. INFORMATION TO USER.....		16
8. HUMAN EXPOSURE COMPLIANCE STATEMENT .....		16

# 1. General Description

SoundCast is a complete point-to-point and point-to-multipoint wireless audio solution. SoundCast digitizes a 2-channel stereo input signal, sends it across a robust radio frequency link, and then converts it back to a stereo analog signal for use at a remote location. SoundCast is ideal for home theater rear speakers, headphones, public address systems, and outdoor speakers.

SoundCast wireless audio product family has two members. SoundCast G2 has 25 meter indoor range while SoundCast G2-ER has 50 meter indoor range. Figure 1 and 2 are the system block diagrams for SoundCast G2 and SoundCast G2-ER modules.

SoundCast G2 TX

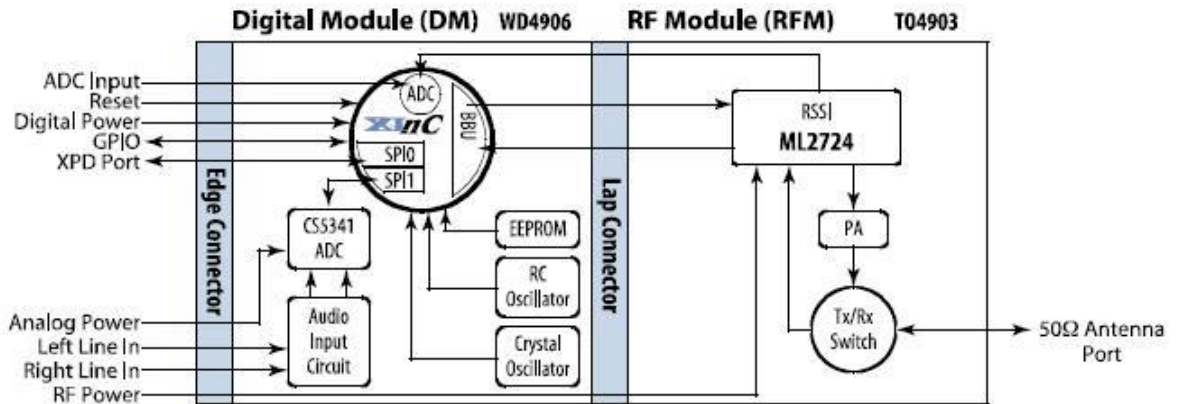

SoundCast G2 RX

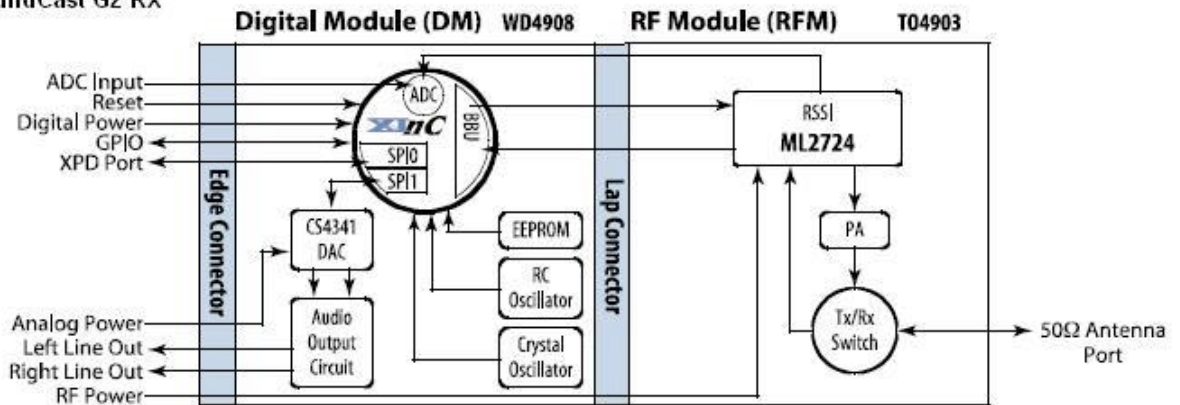
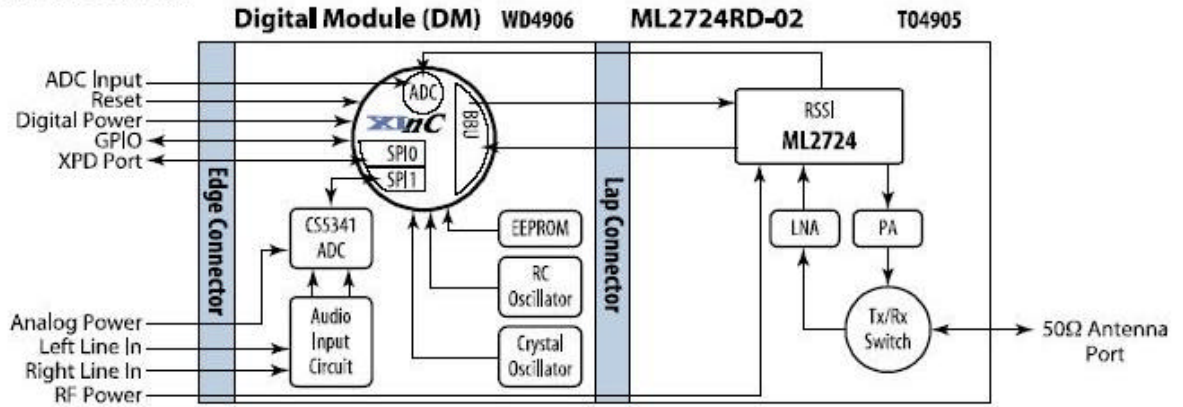

Figure 1, SoundCast G2 system block diagram

SoundCast G2-ER TX



SoundCast G2-ER RX

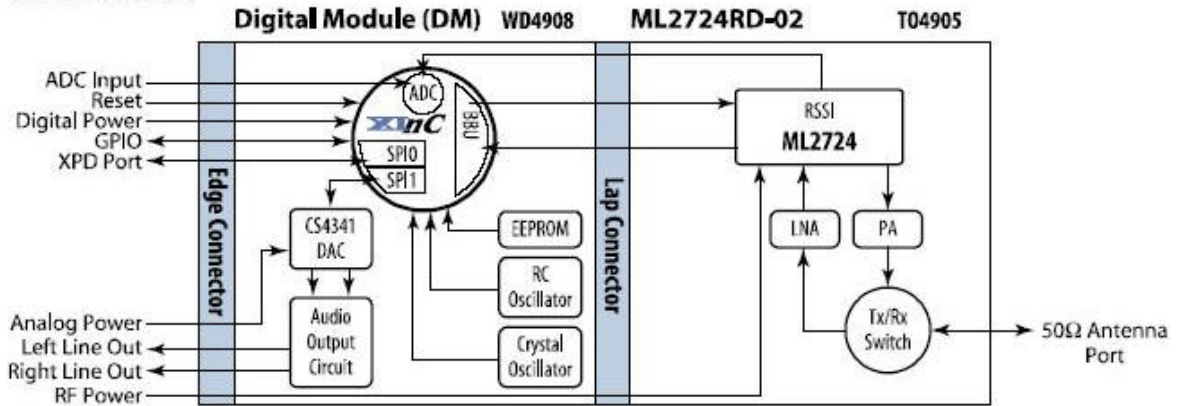

Figure 2, SoundCast G2-ER system block diagram

## 2. Features

- ❖ Stereo Analog In/Analog Out, Digital In/Digital Out;
- ❖ 92.4 dB SNR, 0.065% THD+N;
- ❖ Digital volume control;
- ❖ Auto Mute;
- ❖ Digital Noise Gate;
- ❖ 2.4 GHz wireless link, 1.536 Mbps data rate;
- ❖ 25 m indoor range for the SoundCast G2 module and 45 m indoor range for the SoundCast G2-ER module;
- ❖ Each transmitter supports two receivers with stereo output from both receivers;
- ❖ Up to 6 transmitters in one area;
- ❖ Low latency (15 ms – 64 ms selectable);
- ❖ Low power consumption;
- ❖ Best in Class quality of service (QoS);
- ❖ Duplex utility control channel;
- ❖ Modules come with antenna soldered on for easy integration

### 3. Electrical Specifications

#### 3.1 Operating Conditions – SoundCast G2 Transmitter

Symbol	Parameter	Conditions	Min	Typ	Max	Unit	Note
<b>Power</b>							Current draw
RFVCC	RF Power Supply		3.0	3.3	3.6	V	163mA
VCC	Digital Power Supply		3.2	3.3	3.7	V	76.8mA
AVDD	ADC Power Supply		3.1	3.6	5.5	V	17.9mA
	Power Consumption			863.2		mW	
<b>Logic Thresholds</b>							
Vil	Input Low Voltage Threshold	VCC= 3.3 V			0.8	V	
Vih	Input High Voltage Threshold	VCC= 3.3 V	2.0			V	
Vol	Output Low Voltage Threshold	VCC= 3.3 V			0.4	V	
Voh	Output Low Voltage Threshold	VCC= 3.3 V	2.4			V	
Ioz	Input Leakage Current	VCC= 3.3 V	-10	± 1	10	µA	
<b>Temperature</b>							
TA	Operating Temperature	All Power Ranges	0		50	C	
<b>XInC ADC</b>							
AINx	Input Voltage Range	VCC = 3.3 V	0.35		2.15	V	
Rain	Input Impedance	Single Ended		11		MΩ	
<b>Audio ADC</b>							
LINL, LINR	Full Scale Input Voltage			1.0 0	1.1 0.8	Vrms dBV	
LINL, LINR	Input Impedance			10		KΩ	

Note: All Min/Max characteristics and specifications are guaranteed over the Specified operating conditions. Typical performance characteristics and specifications are derived from measurements taken at typical supply voltages and  $T_A=25^{\circ}\text{C}$ .

#### 3.2 Absolute Maximum Ratings – SoundCast G2 Transmitter

Symbol / Name	Parameter	Value	Unit	Note
RFVCC	RFM Power	3.6	V	See RFM Spec. for details
VCC	Digital Power	4.0	V	
AVDD	ADC Power	5.5	V	
GPIOx, ID_DATA, ID_CLK, /RESET, MISO0, CS0	Digital Input Pin Absolute Maximum Input Voltage	5.5	V	5 V Tolerant Inputs
LINR, LINL	Audio Input Voltage	1.1	Vrms	AC coupled
AINx	XInC's ADC Input	2.5	V	

### 3.3 Operating Conditions – SoundCast G2 Receiver

Symbol	Parameter	Conditions	Min	Typ	Max	Unit	Note
<b>Power</b>							Current draw
RFVCC	RF Power Supply		3.0	3.3	3.6	V	67.3mA
VCC	Digital Power Supply		3.2	3.3	3.7	V	62.2mA
AVDD	DAC Power Supply		2.7	3.6	5.5	V	
	Power Consumption	DAC @ 3.6V		498.7		mW	13.3mA
		DAC @ 5V		535.8		mW	17.2mA
<b>Logic Thresholds</b>							
Vil	Input Low Voltage Threshold	VCC = 3.3 V			0.8	V	
Vih	Input High Voltage Threshold	VCC = 3.3 V	2.0			V	
Vol	Output Low Voltage Threshold	VCC = 3.3 V			0.4	V	
Voh	Output High Voltage Threshold	VCC = 3.3 V	2.4			V	
Ioz	Input Leakage Current	VCC = 3.3 V	-10	± 1	10	µA	
<b>Temperature</b>							
TA	Operating Temperature	All Power Ranges	0		50	C	
<b>XInC ADC</b>							
AINx	Input Voltage Range	VCC = 3.3 V	0.35		2.15	V	
Rain	Input Impedance	Single Ended		11		MΩ	
<b>Audio DAC</b>							
LOUTL, LOUTR	Full Scale Output Voltage	AVDD=3.6V:		0.72 -2.85	0.80 -1.84	Vrms dBV	
		AVDD=5.0V:		1.0 0	1.1 0.8	Vrms dBV	
LOUTL, LOUTR	Output Impedance			100		Ω	

### 3.4 Absolute Maximum Ratings – SoundCast G2 Receiver

Symbol / Name	Parameter	Value	Unit	Note
RFVCC	RFM Power	3.6	V	See RFM Specification for details
VCC	Digital Power	4.0	V	
AVDD	DAC Power	6.0	V	
GPIOx, ID_DATA, ID_CLK, /RESET, MUTE, MISO, CS0	Digital Input Pin Absolute Maximum Input Voltage	5.5	V	5 V Tolerant Inputs
AINx	XInC's ADC Input	2.5	V	



### 3.5 Operating Conditions – SoundCast G2-ER Transmitter

Symbol	Parameter	Conditions	Min	Typ	Max	Unit	Note
<b>Power Consumption</b>							
VCC	Digital Power Supply		3.2		3.7	V	
AVDD	ADC Power Supply		3.1		5.5	V	2
RFVCC	RF Power Supply		3.5		4.5	V	1
Ivcc	Digital Current	VCC=3.3V		64		mA	
Iavdd	Analog Current	AVDD=3.6V		19		mA	2
Irfvcc	RF Current	Transmit Mode: Receive Mode:		180 70		mA mA	1
DCIrfvcc	RF Current Duty Cycle	Transmit Mode: Receive Mode:		92 8	96 4	% %	
<b>Logic Thresholds</b>							
Vil	Input Low Voltage Threshold	VCC= 3.3 V			0.8	V	
Vih	Input High Voltage Threshold	VCC= 3.3 V	2.0			V	
Vol	Output Low Voltage Threshold	VCC= 3.3 V			0.4	V	
Voh	Output High Voltage Threshold	VCC= 3.3 V	2.4			V	
Ioz	Input Leakage Current	VCC= 3.3 V	-10	± 1	10	µA	
<b>Temperature</b>							
TA	Operating Temperature	All Power Ranges	0		50	C	
<b>XInC ADC</b>							
AINx	Input Voltage Range	VCC = 3.3 V	0.35		2.15	V	
Rain	Input Impedance	Single Ended		11		MΩ	
<b>Audio ADC</b>							
LINL, LINR	Full Scale Input Voltage			0.316 -10	1.1 0.828	Vrms dBV	
LINL, LINR	Input Impedance			10		KΩ	

### 3.6 Absolute Maximum Ratings – SoundCast G2-ER Transmitter

Symbol / Name	Parameter	Value	Unit	Note
RFVCC	RFM Power	4.5	V	See ML2724RD-02 Specification for details
VCC	Digital Power	4.0	V	
AVDD	ADC Power	5.5	V	
GPIOx, ID_DATA, ID_CLK, /RESET, MISO0, CS0	Digital Input Pin Absolute Maximum Input Voltage	5.5	V	5 V Tolerant Inputs
LINR, LINL	Audio Input Voltage	1.1	Vrms	AC coupled
AINx	XInC's ADC Input	2.5	V	



### 3.7 Operating Conditions – SoundCast G2-ER Receiver

Symbol	Parameter	Conditions	Min	Typ	Max	Unit	Note
<b>Power Consumption</b>							Current draw
VCC	Digital Power Supply		3.2		3.7	V	
AVDD	DAC Power Supply		2.7		5.5	V	2
RFVCC	RF Power Supply		3.5		4.5	V	1
Ivcc	Digital Current	VCC=3.3V		57		mA	
Iavdd	Analog Current	AVDD=3.6V AVDD=5V		16 21			2
Irfvcc	RF Current	Transmit Mode: Receiver Mode:		180 70		mA mA	1
DCIrfvcc	RF Current Duty Cycle	Transmit Mode: Receiver Mode:		4 96		% %	
<b>Logic Thresholds</b>							
Vil	Input Low Voltage Threshold	VCC = 3.3 V			0.8	V	
Vih	Input High Voltage Threshold	VCC = 3.3 V	2.0			V	
Vol	Output Low Voltage Threshold	VCC = 3.3 V			0.4	V	
Voh	Output High Voltage Threshold	VCC = 3.3 V	2.4			V	
Ioz	Input Leakage Current	VCC = 3.3 V	-10	± 1	10	µA	
<b>Temperature</b>							
TA	Operating Temperature	All Power Ranges	0		50	C	
<b>XInC ADC</b>							
AINx	Input Voltage Range	VCC = 3.3 V	0.35		2.15	V	
Rain	Input Impedance	Single Ended		11		MΩ	
<b>Audio DAC</b>							
LOUTL, LOUTR	Full Scale Output Voltage	AVDD=3.6V: AVDD=5.0V:		0.25 -10 0.364 -10	0.80 -1.94 1.15 1.214	Vrms dBV Vrms dBV	
LOUTL, LOUTR	Output Impedance			100		Ω	

### 3.8 Absolute Maximum Ratings – SoundCast G2-ER Receiver

Symbol / Name	Parameter	Value	Unit	Note
RFVCC	RFM Power	4.5	V	See ML2724RD-02 Specification for details
VCC	Digital Power	4.0	V	
AVDD	DAC Power	6.0	V	
GPIOx, ID_DATA, ID_CLK, /RESET, MUTE, MISO, CS0	Digital Input Pin Absolute Maximum Input Voltage	5.5	V	5 V Tolerant Inputs
AINx	XInC's ADC Input	2.5	V	

## 4. Audio Characteristics

Parameter <sup>1</sup>	Conditions	Symbol	Min	Typ	Max	Unit
<b>SoundCast G2, SoundCast G2-ER</b>						
Audio Input Level (FS) TX Line In	VCC = 3.5V ADC Volts = 3.6V	FSI			1.1 0.83 3.05	V rms dBV dBu
Audio Output Line Level (FS) RX Line Out, Left Channel	VCC = 3.5V DAC Volts = 5.0V	FSO			1.150 1.213 3.432	V rms dBV dBu
Audio Output Line Level (FS) RX Line Out, Right Channel	VCC = 3.5V DAC Volts = 5.0V	FSO			1.150 1.213 3.432	V rms dBV dBu
Default Line output Level	Gain from FSI to FSO			0.365		dB
Line Signal to Noise Ratio A-weighted <sup>2</sup> unweighted	Left Channel, 997 Hz	SNR		- 92.6 - 90.7		dB FS dB FS
Line Signal to Noise Ratio A- weighted <sup>2</sup> unweighted	Right Channel, 997 Hz	SNR		- 92.9 - 90.7		dB FS dB FS
Line THD+N, Left Channel	997 Hz @ - 1 dB FS	THD+N			0.062	%
Line THD+N, Right Channel	997 Hz @ - 1 dB FS	THD+N			0.062	%
Crosstalk, Left into Right or Right into Left	20–20 kHz @ -1 dB FS		65	>65.0	90	dB
Audio Bandwidth	-20 dB FS	BW		20-20 kHz		+/-0.6 dB
Pass Band Ripple					+/- 0.5	dB
Channel Level Difference	- 20 dB FS, 20-20 kHz				<0.10	dB

This table describes the audio characteristics of SoundCast (5.0V supply applied to the DAC on the SoundCast G2 Receiver).

**Note:**

1. All measurements are for 5 bit HFADPCM encoding. 2. Relative to Full Scale Output at RX Line Out, Left Channel. 3. RX Line Out into a 10 k $\Omega$  load.

## 5. RF Characteristics

The SoundCast RF algorithm is described below paying special attention to include information pertinent to FCC and ETSI regulations. The SoundCast software operates by selecting a palette (or group) of 15 random channels out of the total 38 to hop on. For the 15-channel palette, any channels with poor transmission rates are replaced with better channels from the remaining 23 unused channels. The hopping pattern from channel to channel is a random pattern. The following table describes some important aspects of the channel-hopping algorithm:

Symbol	Parameter	Conditions	Min	Typ	Max	Unit	Note
<b>RF Characteristics</b>							
	Transmission Method		Hybrid FEC/ARQ with AFH				
Rdr	Raw Data Rate				1536	kbps	
	Frequency Range		2.4		2.48	GHz	
Fw	Channel Width			2		MHz	
CH	Total Channels			38		Ch	
CHh	Hopping Channels			15		Ch	
	RF Coexistence			6		sets	
ZAnt	Antenna Impedance			50		$\Omega$	
<b>Detailed RF Bandwidth Characteristics</b>							
	Hopping Rate			187.5		Hz	
	Frequency Dwell Time			5.333		ms	
	Audio Tx: RF Transmit Time	Start of Frame		4.9036		ms	
	Audio Rx: RF Transmit Time	End of Frame		0.2132		ms	
	Frequency Range(low/high)		2.40197		2.48002	GHz	
	Frequency Range(total)			78.057		MHz	
	20dB Channel BW			1.94		MHz	
	Distance to upper ISM band limit			3.476		MHz	
	Distance to lower ISM band limit			1.967		MHz	
<b>Center Frequencies (ODD Channel Table)</b>							
Channel #	Center Frequency (GHz)	Channel #	Center Frequency (GHz)				
0	2.403328	19	2.442240				
1	2.405376	20	2.444288				
2	2.407424	21	2.446336				
3	2.409472	22	2.448384				
4	2.411520	23	2.450432				
5	2.413568	24	2.452480				
6	2.415616	25	2.454528				
7	2.417664	26	2.456576				
8	2.419712	27	2.458624				
9	2.421760	28	2.460672				
10	2.423808	29	2.462720				
11	2.425856	30	2.464768				
12	2.427904	31	2.466816				
13	2.429952	32	2.468864				
14	2.432000	33	2.470912				
15	2.434048	34	2.472960				
16	2.436096	35	2.475008				
17	2.438144	36	2.477056				
18	2.440192	37	2.479104				

### 5.1 RF Characteristics - SoundCast G2 Transmitter and Receiver

Symbol	Parameter	Conditions	Min	Typ	Max	Unit	Note
<b>RF Characteristics</b>							
	Transmission Method		Hybrid FEC/ARQ with AFH				
Rdr	Raw Data Rate				1536	kbps	
	Frequency Range		2.4		2.48	GHz	
Fw	Channel Width			2		MHz	
CH	Total Channels			38		Ch	
CHh	Hopping Channels			15		Ch	
	RF Coexistence			6		sets	
Pout	TX Output Power				14	dBm	
ZAnt	Antenna Impedance			50		$\Omega$	
Div	Antenna Diversity	WHAM2 Rx only	1	1	2	Ant's	Opt.
<b>RF Range</b>							
	Indoor Range <sup>1</sup>				25	m	1
	Outdoor Range <sup>2</sup>				470	m	
<sup>1</sup> Typical office environment <sup>2</sup> Outside open field measurement							

### 5.2 RF Characteristics - SoundCast G2-ER Transmitter and Receiver

Symbol	Parameter	Conditions	Min	Typ	Max	Unit	Note
<b>RF Characteristics</b>							
	Transmission Method		Hybrid FEC/ARQ with AFH				
Rdr	Raw Data Rate				1536	kbps	
	Frequency Range		2.40		2.48	GHz	
Fw	Channel Width			2.048		MHz	
CH	Total Channels			38		Ch	
CHh	Hopping Channels			15		Ch	
	RF Coexistence			6		sets	
Pout	TX Output Power	At 2.45MHz matched to 50 $\Omega$			19	dBm	
ZAnt	Antenna Impedance			50		$\Omega$	
Div	Antenna Diversity	WHAM2 Rx only		1		Ant	
<b>RF Range</b>							
	Indoor Range <sup>1</sup>				50	m	1
	Outdoor Range <sup>2</sup>				1000	m	
<sup>1</sup> Typical office environment <sup>2</sup> Outside open field measurement							



## 6. Pin Description

### 6.1 Pin Description - SoundCast G2 and G2-ER Transmitter

SoundCast Transmitter Pinout\*



Pin #	Pin Name	Description
1	RFVCC	RF Voltage Power Input
2	RFGND	RF GND
3	GND	Digital GND
4	VCC	Digital Power Input
5	/RESET	Active low reset line
6	PB1(CS0)	SPI0 Chip Select
7	MISO0	SPI0 Master Data Input
8	MOSI0	SPI0 Master Data Output
9	SCK0	SPI0 Clock
10	PE0(ID_DATA)	Serial data input from external parallel to serial shift register
11	PE1(ID_CLK)	Bit clock for external shift registers
12	PH0(ID_LOAD)	Load serial-input shift register from parallel data input
13	PH1	General Purpose IO
14	PH2	General Purpose IO
15	PH3/MCLK	General Purpose IO (PH3= Power_Button)
16	PH4/AN2	XInC ADC Analog Input #2
17	PH5/AN1	XInC ADC Analog Input #1
18	PH6	General Purpose IO (PH6=Shutdown Output)
19	PG0/LRCK	General Purpose IO
20	PG1/MOSI1	General Purpose IO
21	AGND	Analog GND
22	AINR/MISO1	Audio line in for Right Channel
23	AINL/SCK1	Audio line in for Left Channel
24	AGND	Analog GND
25	AVDD	Analog Power Input

\*Default Configuration. Several Pins are Software Configurable

## 6.2 Pin Description - SoundCast G2 and G2-ER Receiver

SoundCast Receiver Pinout\*



Pin #	Pin Name	Description
1	RFVCC	RF Voltage Power Input
2	RFGND	RF GND
3	GND	Digital GND
4	VCC	Digital Power Input
5	/RESET	Active low reset line
6	PB1(CS0)	SPI0 Chip Select
7	MISO0	SPI0 Master Data Input
8	MOSI0	SPI0 Master Data Output
9	SCK0	SPI0 Clock
10	PE0(ID_DATA)	Serial data input from external parallel to serial shift register
11	PE1(ID_CLK)	Bit clock for external shift registers
12	PH0(ID_LOAD)	Load serial-input shift register from parallel data input
13	PH1	General Purpose IO
14	PH2	General Purpose IO
15	PH3	General Purpose IO (PH3=Power Shutdown Output)
16	PH4/MCLK	General Purpose IO
17	PH5/AN2	XInC ADC Analog Input #2
18	PH6/AN1	XInC ADC Analog Input #1
19	PG0/LRCK	General Purpose IO
20	PG1/MISO1	General Purpose IO
21	AGND	Analog GND
22	AOUTR/MOSI1	Audio line out for Right Channel
23	AOUTL/SCK1	Audio line out for Left Channel
24	AGND	Analog GND
25	AVDD	Analog Power Input

\*Default Configuration. Several Pins are Software Configurable

## 7. Information to User

This device complies with Part 15 of the FCC Rules. Operation is subject to the following two conditions: (1) This device may not cause harmful interference, and (2) This device must accept any interference received, including interference that may cause undesired operation.

This equipment has been tested and found to comply with the limits for Class B Digital Device, pursuant to Part 15 of the FCC Rules. These limits are designed to provide reasonable protection against harmful interference in a residential installation. This equipment generates and can radiate radio frequency energy and, if not installed and used in accordance with the instructions, may cause harmful interference to radio communications. However, there is no guarantee that interference will not occur in a particular installation. If this equipment does cause harmful interference to radio or television reception, which can be determined by turning the equipment off and on, the user is encouraged to try to correct the interference by one or more of the following measures.

- Reorient or relocate the receiving antenna
- Increase the separation between the equipment and receiver
- Connect the equipment into an outlet on a circuit different from that to which the receiver is connected
- Consult the dealer or an experienced radio/TV technician for help

Any changes or modifications not expressly approved by the party responsible for compliance could void the user's authority to operate the equipment.

All products in which this device will be installed shall be labeled with "This device complies with Part 15 of the FCC Rules. Operation is subject to the following two conditions: (1) This device may not cause harmful interference, and (2) This device must accept any interference received, including interference that may cause undesired operation" and "This device contains FCC ID: SUD-SCG2 / IC: 5613A-SCG2" or "This device contains FCC ID: SUD-SCG2ER / IC: 5613A-SCG2ER" as appropriate for model.

## 8. Human Exposure Compliance Statement

The following statement addressing human exposure to the RF energy emitted by SCG2 and SCG2ER wireless audio systems is included in the "User's Manual." Pursuant to 47 CFR § 15C of the FCC Rules and Regulations. KSC Industries, Inc. certifies that it has determined that the SCG2 and SCG2ER comply with the RF hazard requirements applicable to unlicensed transmitters under the authority of 47 CFR Part 15 of the FCC Rules and Regulations. This determination is dependent upon installation, operation and use of the equipment in accordance with all instructions provided. The SCG2 and SCG2ER are designed for and intended to be used in fixed and mobile applications. "Fixed" means that the device is physically secured at one location and is not able to be easily moved to another location. "Mobile" means that the device is designed to be used in other than fixed locations and generally in such a way that a separation distance of at least 20 cm is normally maintained between the transmitter's antenna and the body of the user or nearby persons. The EUT is not designed for or intended to be used in portable applications (within 20 cm of the body of the user) and such uses are strictly prohibited. To ensure that the SCG2 and SCG2ER comply with current FCC regulations limiting both maximum RF output power and human exposure to radio frequency radiation, a separation distance of at



least 20 cm must be maintained between the unit's antenna and the body of the user and any nearby persons at all times and in all applications and uses.