

FCC TEST REPORT
for
Controlled Entry Distributors, Inc.

Standalone RFID Reader
Model No.: DOLCMSA2KH, DOLCSSA2KH

Prepared for : Controlled Entry Distributors, Inc.
Address : 2500 South 3850 West, Suite A, Salt Lake City, UT 84120 USA

Prepared By : Shenzhen Anbotek Compliance Laboratory Limited
Address : 1/F., Building 1, SEC Industrial Park, No.0409 Qianhai Road,
Nanshan District, Shenzhen, Guangdong, China
Tel: (86) 755-26066544
Fax: (86) 755-26014772

Report Number : 201311950F
Date of Test : Nov. 26~ Dec. 09, 2013
Date of Report : Dec. 09, 2013

TABLE OF CHONTENTS

Description

Page

Test Report Verification

1. GENERAL INFORMATION	4
1.1. Description of Device (EUT)	4
1.2. Description of Test Facility	5
1.3. Measurement Uncertainty	5
2. TEST PROCEDURE	6
3. POWER LINE CONDUCTED MEASUREMENT	7
3.1. Block Diagram of Test Setup	7
3.2. Power Line Conducted Emission Measurement Limits (FCC Part 15 15.207).....	7
3.3. Configuration of EUT on Measurement.....	7
3.4. Operating Condition of EUT.....	7
3.5. Test Procedure.....	8
3.6. Power Line Conducted Emission Measurement Results.....	8
4. RADIATED EMISSION MEASUREMENT.....	11
4.1. Radiated Emission Limits	11
4.2. Test Procedure.....	11
4.3. Test Setup.....	12
4.4. Test Results (Below 30MHz).....	14
4.5. Test Results (Between 30-1000MHz)	14
5. OCCUPIED BANDWIDTH.....	17
5.1. Requirements (2.1049):.....	17
5.2. Test Procedure.....	17
5.4. Test Results	17
6. TEST SETUP PHOTOGRAPH.....	19
6.1. Photo of Conducted Emission Measurement	19
6.2. Photo of Radiation Emission Test.....	19

APPENDIX I (External Photos) (2 Pages)

APPENDIX II (Internal Photos) (2 Pages)

TEST REPORT VERIFICATION

Applicant : Controlled Entry Distributors, Inc.
Manufacturer : Controlled Entry Distributors, Inc.
EUT : Standalone RFID Reader
Model No. : DOLCMSA2KH, DOLCSSA2KH
Rating : DC 9-18V, <40mA
Trade Mark : N/A

Measurement Procedure Used:

FCC Rules and Regulations Part 15 Subpart C 15.207&15.209-2012, Part 2: 2012 & FCC / ANSI C63.4-2009

The device described above is tested by Shenzhen Anbotek Compliance Laboratory Limited To determine the maximum emission levels emanating from the device. The maximum emission levels are compared to the FCC Part 15 Subpart C limits both radiated and conducted emissions. The measurement results are contained in this test report and Shenzhen Anbotek Compliance Laboratory Limited Is assumed full responsibility for the accuracy and completeness of these measurements. Also, this report shows that the Equipment Under Test (EUT) is to be technically compliant with the FCC requirements.

This report applies to above tested sample only. This report shall not be reproduced in part without written approval of Shenzhen Anbotek Compliance Laboratory Limited.

Date of Test : Nov. 26~ Dec. 09, 2013

Prepared by : 
(Engineer/ Rock Zeng)

Reviewer : 
(Project Manager/ Sally Zhang)

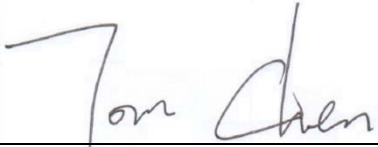
Approved & Authorized Signer : 
(Manager/ Tom Chen)

1. GENERAL INFORMATION

1.1. Description of Device (EUT)

Description : Standalone RFID Reader

Model Number : DOLCMSA2KH, DOLCSSA2KH
(Note: All samples are the same except the model number & appearance, so we prepare “DOLCSSA2KH” for EMC test only.)

Test Power Supply : DC 18V

Frequency : 125KHz

Applicant : Controlled Entry Distributors, Inc.
Address : 2500 South 3850 West, Suite A, Salt Lake City, UT 84120
USA

Manufacturer : Secukey Technology Co., Ltd
Address : 3/F, Building 8, Xintang Industrial Park, Fuyong, Bao'an District, Shenzhen, China

Date of Sample received : Nov. 26, 2013

Date of Test : Nov. 26~ Dec. 09, 2013

1.2. Description of Test Facility

The test facility is recognized, certified, or accredited by the following organizations:

CNAS - LAB Code: L3503

Shenzhen Anbotek Compliance Laboratory Limited., Laboratory has been assessed and in compliance with CNAS/CL01: 2006 accreditation criteria for testing laboratories (identical to ISO/IEC 17025:2005 General Requirements) for the Competence of Testing Laboratories.

FCC-Registration No.: 752021

Shenzhen Anbotek Compliance Laboratory Limited, EMC Laboratory has been registered and fully described in a report filed with the (FCC) Federal Communications Commission. The acceptance letter from the FCC is maintained in our files. Registration 752021, July 10, 2013.

IC-Registration No.: 8058A-1

Shenzhen Anbotek Compliance Laboratory Limited., EMC Laboratory has been registered and fully described in a report filed with the (IC) Industry Canada. The acceptance letter from the IC is maintained in our files. Registration 8058A-1, February 22, 2013.

Test Location

All Emissions tests were performed
1/F., Building 1, SEC Industrial Park, No.0409 Qianhai Road, Nanshan District,
Shenzhen, Guangdong, China

1.3. Measurement Uncertainty

Radiation Uncertainty	:	Ur = 4.3dB
Conduction Uncertainty	:	Uc = 3.4dB

2. Test Procedure

GENERAL: This report shall NOT be reproduced except in full without the written approval of Shenzhen Anbotek Compliance Laboratory Limited. The EUT was transmitting a test signal during the testing.

RADIATION INTERFERENCE: The test procedure used was ANSI STANDARD C63.4-2009 using a spectrum analyzer with a pre-selector. The analyzer was calibrated in dB above a microvolt at the output of the antenna. The resolution bandwidth was 100KHz and the video bandwidth was 300KHz up to 1.0GHz and 1.0MHz with a video BW of 3.0MHz above 1.0GHz. The ambient temperature of the EUT was 74.3oF with a humidity of 69%.

FORMULA OF CONVERSION FACTORS: The Field Strength at 3m was established by adding the meter reading of the spectrum analyzer (which is set to read in units of dBuV) to the antenna correction factor supplied by the antenna manufacturer. The antenna correction factors are stated in terms of dB. The gain of the Preselector was accounted for in the Spectrum Analyzer Meter Reading.

Example:

Freq (MHz) METER READING + ACF = FS
33 20 dBuV + 10.36 dB = 30.36 dBuV/m @ 3m

ANSI STANDARD C63.4-2009 10.1.7 MEASUREMENT PROCEDURES: The EUT was placed on a table 80 cm high and with dimensions of 1m by 1.5m. The EUT was placed in the center of the table (1.5m side). The table used for radiated measurements is capable of continuous rotation.

When an emission was found, the table was rotated to produce the maximum signal strength. At this point, the antenna was raised and lowered from 1m to 4m. The antenna was placed in both the horizontal and vertical planes.

3. POWER LINE CONDUCTED MEASUREMENT

3.1. Block Diagram of Test Setup

3.1.1 Block diagram of connection between the EUT and simulators

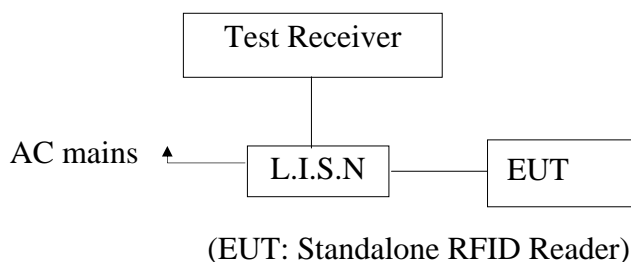

3.2. Power Line Conducted Emission Measurement Limits (FCC Part 15

15.207)

Frequency MHz	Limits dB(μV)	
	Quasi-peak Level	Average Level
0.15 ~ 0.50	66 ~ 56*	56 ~ 46*
0.50 ~ 5.00	56	46
5.00 ~ 30.00	60	50

Notes: 1. *Decreasing linearly with logarithm of frequency.

2. The lower limit shall apply at the transition frequencies.

3.3. Configuration of EUT on Measurement

The following equipments are installed on Power Line Conducted Emission Measurement to meet the commission requirement and operating regulations in a manner which tends to maximize its emission characteristics in a normal application.

EUT : Standalone RFID Reader
Model Number : DOLCSSA2KH
Applicant : Controlled Entry Distributors, Inc.

3.4. Operating Condition of EUT

3.4.1. Setup the EUT and simulator as shown as Section 3.1.

3.4.2. Turn on the power of all equipment.

3.4.3. Let the EUT work in test mode (ON) and measure it.

3.5. Test Procedure

The EUT system is connected to the power mains through a line impedance stabilization network (L.I.S.N.). This provides a 50ohm coupling impedance for the EUT system. Please refer the block diagram of the test setup and photographs. Both sides of AC line are checked to find out the maximum conducted emission. In order to find the maximum emission levels, the relative positions of equipment and all of the interface cables shall be changed according to FCC ANSI C63.4-2009 on Conducted Emission Measurement.

The bandwidth of test receiver (ESCI) set at 9KHz.

The frequency range from 150KHz to 30MHz is checked.

The test result are reported on Section 3.6.

Test Equipment

Item	Equipment	Manufacturer	Model No.	Serial No.	Last Cal.	Cal. Interval
1.	Two-Line V-network	Rohde & Schwarz	ENV216	100055	Apr. 23, 2013	1 Year
2.	EMI Test Receiver	Rohde & Schwarz	ESCI	100627	Apr. 23, 2013	1 Year
3.	RF Switching Unit	Compliance Direction	RSU-M2	38303	Apr. 23, 2013	1 Year

Conduction Uncertainty : $U_c = 3.4\text{dB}$

3.6. Power Line Conducted Emission Measurement Results

PASS.

The frequency range from 150KHz to 30 MHz is investigated.

Please refer the following pages.

CONDUCTED EMISSION TEST DATA

Test Site: 1# Shielded Room
 Operating Condition: On
 Operator: Bevan Zhang
 Test Specification: DC 18V
 Comment: +
 Tem:25°C Hum:50%

SCAN TABLE: "Voltage (150K~30M) FIN"

Short Description: 150K-30M Disturbance Voltages

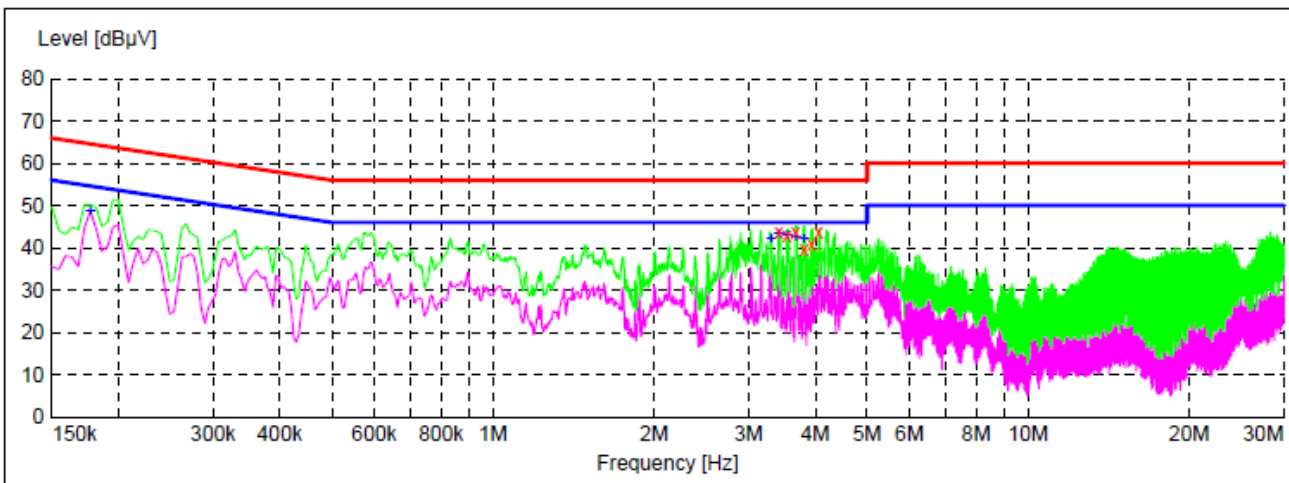

x x x MES AT1311890110_fin

MEASUREMENT RESULT: "AT1311890110_fin"

11/28/2013 2:31PM

Frequency MHz	Level dBµV	Transd dB	Limit dBµV	Margin dB	Detector	Line	PE
3.421000	43.60	10.4	56	12.4	QP	L1	GND
3.547000	43.00	10.4	56	13.0	QP	L1	GND
3.677500	43.60	10.4	56	12.4	QP	L1	GND
3.817000	39.70	10.4	56	16.3	QP	L1	GND
3.943000	41.10	10.4	56	14.9	QP	L1	GND
4.064500	43.60	10.5	56	12.4	QP	L1	GND

MEASUREMENT RESULT: "AT1311890110_fin2"

11/28/2013 2:31PM

Frequency MHz	Level dBµV	Transd dB	Limit dBµV	Margin dB	Detector	Line	PE
0.177000	48.80	10.1	55	5.8	AV	L1	GND
3.308500	42.10	10.4	46	3.9	AV	L1	GND
3.421000	43.20	10.4	46	2.8	AV	L1	GND
3.547000	43.10	10.4	46	2.9	AV	L1	GND
3.677500	42.50	10.4	46	3.5	AV	L1	GND
3.808000	42.10	10.4	46	3.9	AV	L1	GND

CONDUCTED EMISSION TEST DATA

Test Site: 1# Shielded Room
 Operating Condition: On
 Operator: Bevan Zhang
 Test Specification: DC 18V
 Comment: -
 Tem:25°C Hum:50%

SCAN TABLE: "Voltage (150K~30M) FIN"

Short Description: 150K-30M Disturbance Voltages

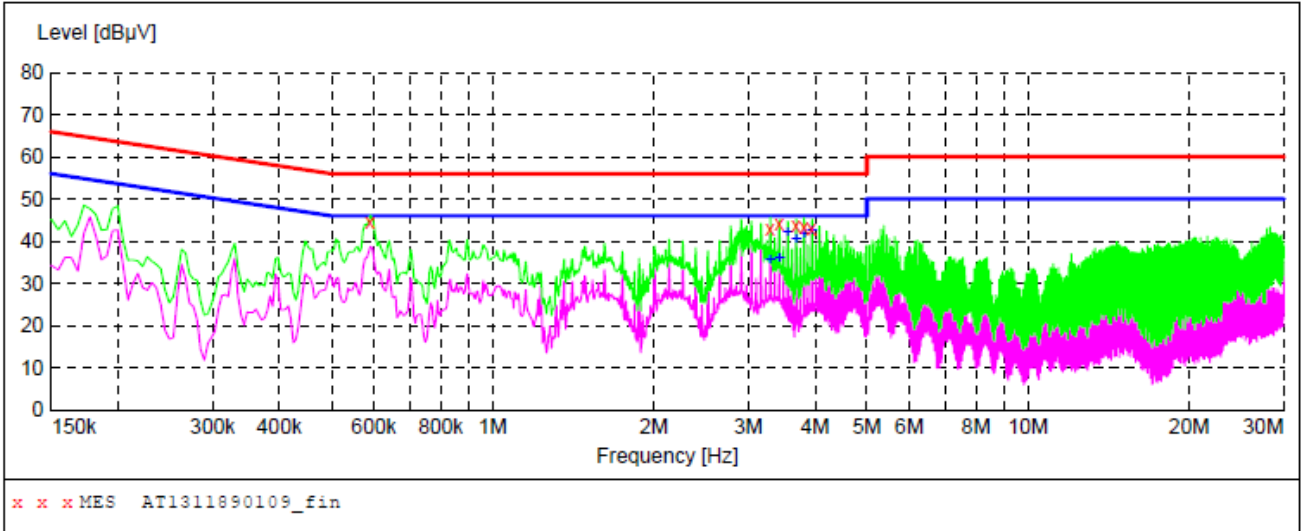

MEASUREMENT RESULT: "AT1311890109_fin"

11/28/2013 2:28PM

Frequency MHz	Level dBµV	Transd dB	Limit dBµV	Margin dB	Detector	Line	PE
0.591000	44.50	10.1	56	11.5	QP	N	GND
3.299500	43.00	10.4	56	13.0	QP	N	GND
3.430000	44.30	10.4	56	11.7	QP	N	GND
3.686500	43.80	10.4	56	12.2	QP	N	GND
3.817000	43.50	10.4	56	12.5	QP	N	GND
3.947500	42.80	10.4	56	13.2	QP	N	GND

MEASUREMENT RESULT: "AT1311890109_fin2"

11/28/2013 2:28PM

Frequency MHz	Level dBµV	Transd dB	Limit dBµV	Margin dB	Detector	Line	PE
3.299500	35.50	10.4	46	10.5	AV	N	GND
3.430000	36.00	10.4	46	10.0	AV	N	GND
3.560500	42.20	10.4	46	3.8	AV	N	GND
3.686500	40.50	10.4	46	5.5	AV	N	GND
3.817000	41.80	10.4	46	4.2	AV	N	GND
3.947500	42.50	10.4	46	3.5	AV	N	GND

4. RADIATED EMISSION MEASUREMENT

4.1. Radiated Emission Limits

Frequency (MHz)	Field Strength Limitation		Field Strength Limitation at 3m Measurement Dist	
	(uV/m)	Dist	(uV/m)	(dBuV/m)
0.009 – 0.490	2400 / F(KHz)	300m	10000 * 2400/F(KHz)	20log 2400/F(KHz) + 80
0.490 – 1.705	24000 / F(KHz)	30m	100 * 24000/F(KHz)	20log 24000/F(KHz) + 40
1.705 – 30.00	30	30m	100* 30	20log 30 + 40
30.0 – 88.0	100	3m	100	20log 100
88.0 – 216.0	150	3m	150	20log 150
216.0 – 960.0	200	3m	200	20log 200
Above 960.0	500	3m	500	20log 500

Note:

- (1) The tighter limit shall apply at the boundary between two frequency range.
- (2) Limitation expressed in dBuV/m is calculated by 20log Emission Level (uV/m).
- (3) If measurement is made at 3m distance, then F.S Limitation at 3m distance is adjusted by using the formula of $Ld1 = Ld2 * (d2/d1)^2$.

Example:

F.S Limit at 30m distance is 30uV/m , then F.S Limitation at 3m distance is adjusted as $Ld1 = L1 = 30uV/m * (10)^2 = 100 * 30 uV/m$

4.2. Test Procedure

- a. The measuring distance of at 3 m shall be used for measurements at frequency up to 1GHz. For frequencies above 1GHz, any suitable measuring distance may be used.
- b. The EUT was placed on the top of a rotating table 0.8 meters above the ground at a 3m meter open area test site. The table was rotated 360 degrees to determine the position of the highest radiation.
- c. The height of the equipment or of the substitution antenna shall be 0.8 m; the height of the test antenna shall vary between 1 m to 4 m. Both horizontal and vertical polarizations of the antenna are set to make the measurement.
- d. The initial step in collecting conducted emission data is a spectrum analyzer peak detector mode pre-scanning the measurement frequency range. Significant peaks are then marked and then Quasi Peak detector mode re-measured.
- e. If the Peak Mode measured value compliance with and lower than Quasi Peak Mode Limit, the EUT shall be deemed to meet QP Limits and then no additional QP Mode measurement performed.
- f. For the actual test configuration, please refer to the related Item –EUT Test Photos.

4.3. Test Setup

(A) Radiated Emission Test Set-Up, Frequency below 30MHz

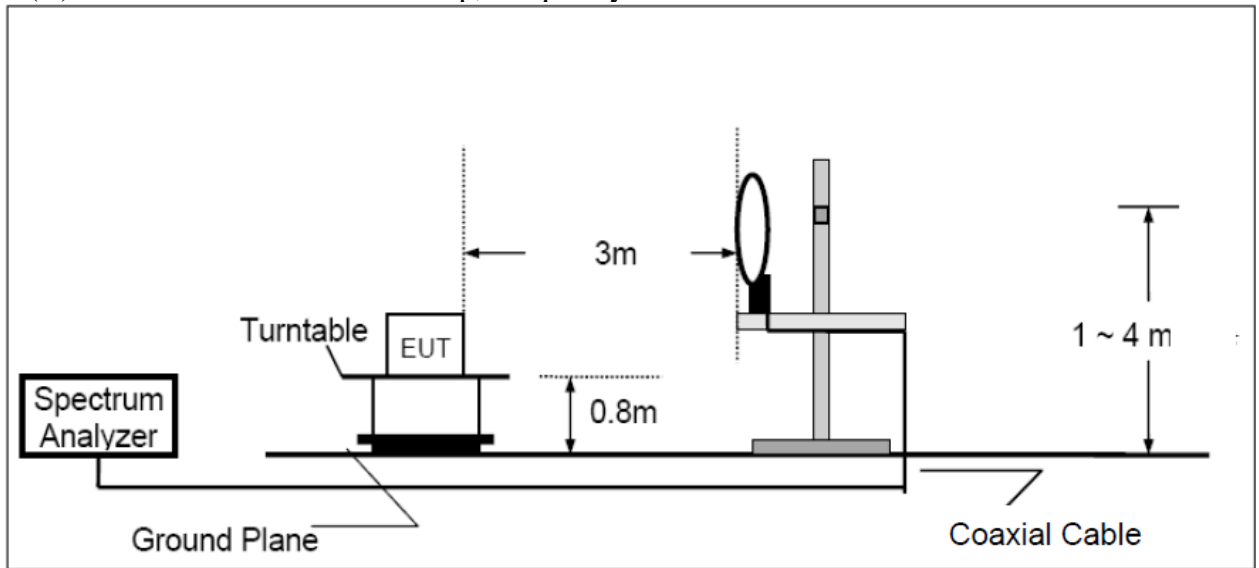

(B) Radiated Emission Test Set-Up, Frequency 30-1000MHz

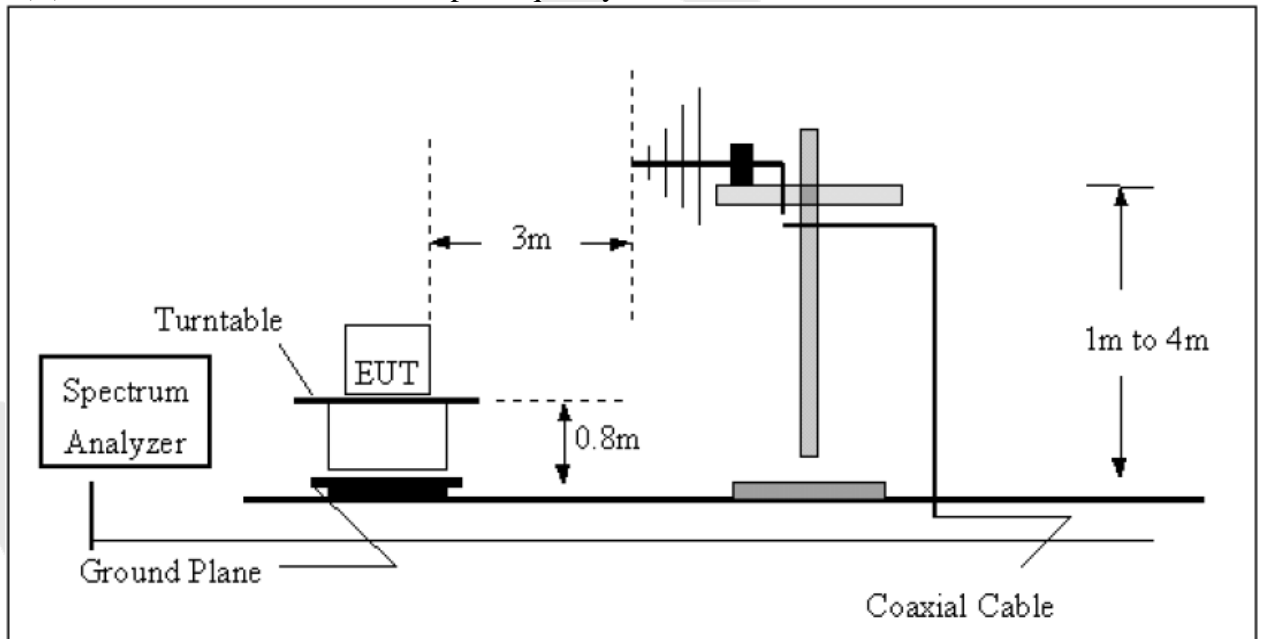

Test Equipment

Item	Equipment	Manufacturer	Model No.	Serial No.	Last Cal.	Cal. Interval
1.	EMI Test Receiver	Rohde & Schwarz	ESPI	101604	Apr. 23, 2013	1 Year
2.	Bilog Broadband Antenna	Schwarzbeck	VULB9163	VULB 9163-289	May 14, 2013	3 Year
3.	Pre-amplifier	SONOMA	310N	186860	Aug. 09, 2013	1 Year
4.	EMI Test Software EZ-EMC	SHURPLE	N/A	N/A	N/A	N/A

Radiation Uncertainty : Ur = 4.3dB

4.4. Test Results (Below 30MHz)

Freq.(KHz)	Reading at 3m (dBuV/m)	Factor (dB) Cable loss	Result at 3m (dBuV/m)	Field Strength Limit (uV/m)	Required Measurement Distance (m)	Limitation Converted 3m dist. (dBuV/m)	Over Limit (dB)	Detector (PK/AV)
125.00	79.51	16.00	95.51	19.20	300.00	105.67	-10.16	PK
250.00	49.03	15.60	64.63	9.6	300.00	99.66	-35.03	PK
375.00	46.21	15.30	61.51	6.4	300.00	96.12	-34.61	PK
500.00	44.85	14.80	59.65	48	30.00	73.62	-13.97	PK
625.00	42.71	14.50	57.21	38.4	30.00	71.69	-14.48	PK
800.00	38.04	13.95	51.99	30	30.00	69.54	-17.55	PK
925.00	--	--	--	--	--	--	--	--
1050.00	--	--	--	--	--	--	--	--
1250.00	--	--	--	--	--	--	--	--
1500.00	--	--	--	--	--	--	--	--

Remark:

(1) Spectrum Setting:

9 KHz – 150 KHz, RBW= 1 KHz, VBW=1 KHz, Sweep time = 200 ms.

150 K Hz – 30 MHz, RBW= 9 KHz, VBW=9 KHz, Sweep time = 200 ms.

(2) All readings are Peak unless otherwise stated QP in column of 『Note』 . Peak denotes that the Peak reading compliance with the QP Limits and then QP Mode measurement didn't perform.

(3) The Log-Bicon Antenna will use to test frequency range from 30MHz to 1000MHz and the Loop Antenna will use to test frequency below 30MHz.

(4) If the peak scan value lower limit more than 20dB, then this signal data does not show in table

4.5. Test Results (Between 30-1000MHz)

Pass

The test curves are shown in the following pages.

Job No.:	AT1311890F	Polarization:	Horizontal
Standard:	(RE)FCC PART15 C_3m	Power Source:	DC 18V
Test item:	Radiation Test	Test By:	Rock Zeng
Temp.(C)/Hum.(%RH):	24.3(C)/55%RH	Distance:	3m
Mode:	ON		

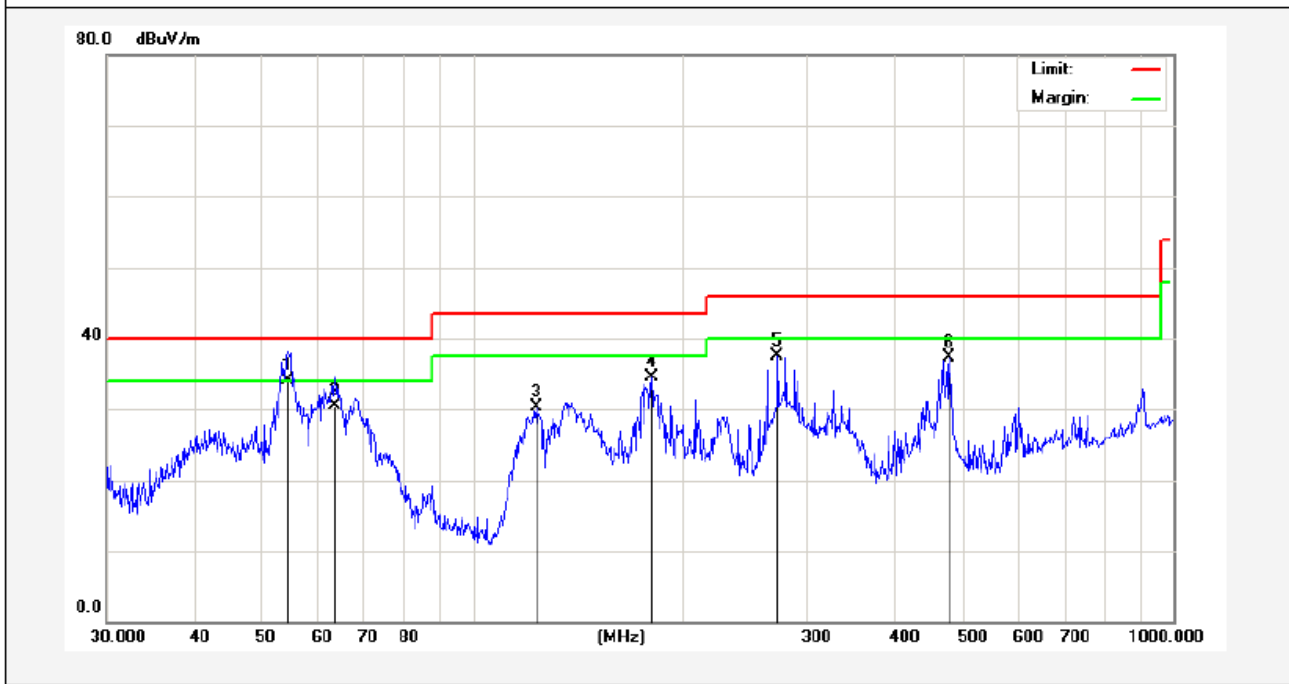

No.	Freq. (MHz)	Reading (dBuV/m)	Factor (dB/m)	Result (dBuV/m)	Limit (dBuV/)	Over Limit (dB)	Detector	Height (cm)	degree (deg)	Remark
1	54.4515	48.96	-14.88	34.08	40.00	-5.92	QP	100	0	
2	63.5356	47.36	-16.86	30.50	40.00	-9.50	QP	100	360	
3	123.2655	52.11	-21.82	30.29	43.50	-13.21	peak			
4	180.0165	56.33	-21.85	34.48	43.50	-9.02	peak			
5	272.2776	55.97	-18.52	37.45	46.00	-8.55	peak			
6	478.8455	48.79	-11.57	37.22	46.00	-8.78	peak			

Job No.:	AT1311890F	Polarization:	Vertical
Standard:	(RE)FCC PART15 C_3m	Power Source:	DC 18V
Test item:	Radiation Test	Test By:	Rock Zeng
Temp.(C)/Hum.(%RH):	24.3(C)/55%RH	Distance:	3m
Mode:	ON		

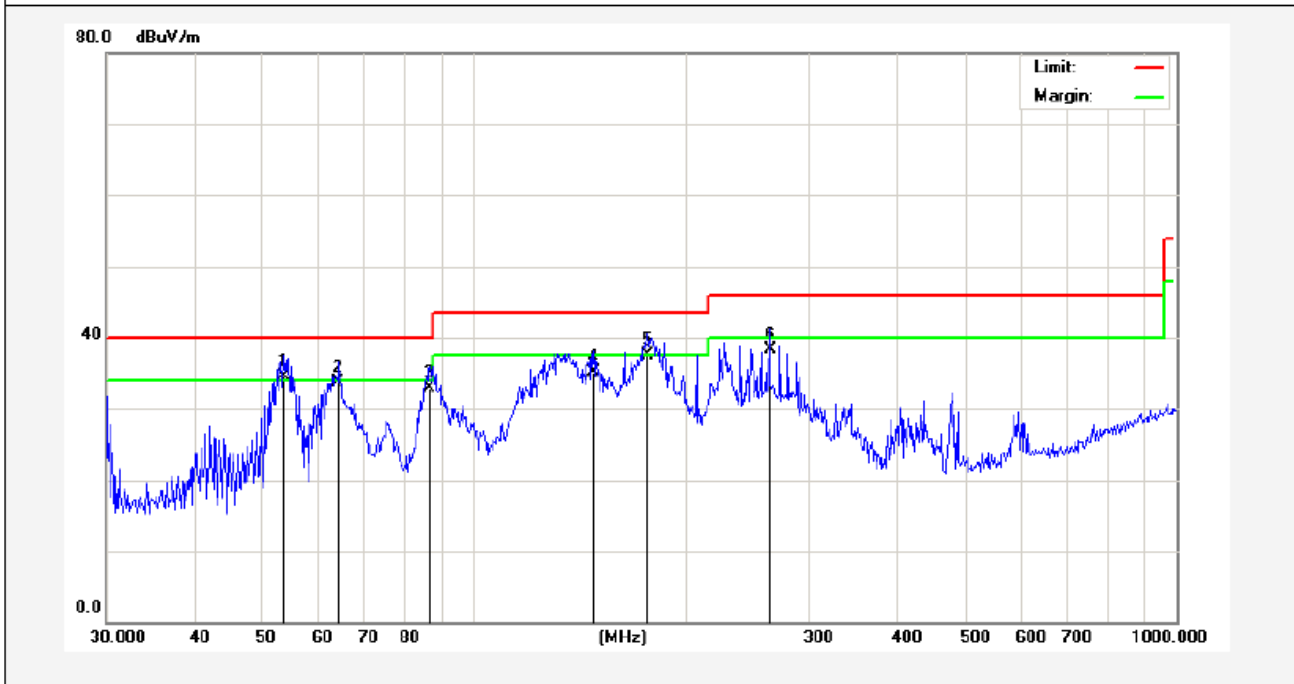

No.	Freq. (MHz)	Reading (dBuV/m)	Factor (dB/m)	Result (dBuV/m)	Limit (dBuV/)	Over Limit (dB)	Detector	Height (cm)	degree (deg)	Remark
1	53.6931	49.35	-14.84	34.51	40.00	-5.49	QP	100	0	
2	64.2074	50.89	-17.15	33.74	40.00	-6.26	QP	100	360	
3	86.5027	51.15	-18.20	32.95	40.00	-7.05	QP	100	0	
4	147.9214	53.51	-18.37	35.14	43.50	-8.36	QP	100	360	
5	176.8876	54.53	-17.06	37.47	43.50	-6.03	QP	100	0	
6	263.8190	52.49	-14.22	38.27	46.00	-7.73	QP	100	360	

5. Occupied Bandwidth

5.1. Requirements (2.1049):

The occupied bandwidth is measured as the 99% emission bandwidth, the frequency bandwidth such that, below its lower and above its upper frequency limits, the mean powers radiated are each equal to 0.5 percent of the total mean power radiated by a given emission.

5.2. Test Procedure

1. Connect EUT's antenna terminal to the spectrum analyser via a low loss cable with transmitting mode. Measurements were made while the EUT was being powered with DC 18V battery.
2. Adjust the centre frequency of the spectrum analyser on the frequency be measured, and set for peak detector mode, max. hold trace mode.
RBW= 300 Hz, VBW= 1KHz
3. The span of the analyzer shall be set to capture all products of the modulation process including the emission skirts. Use the marker-peak function to set the marker to the peak of the emission.
4. Use the OBW function to measure 99% emission bandwidth, record the occupied bandwidth value.

Test Equipment

Item	Equipment	Manufacturer	Model No.	Serial No.	Last Cal.	Cal. Interval
1.	Spectrum Analysis	Agilent	E4407B	US39390582	Aug. 09, 2013	1 Year
2.	Preamplifier	Instruments corporation	EMC011830	980100	Aug. 09, 2013	1 Year
3.	Pre-amplifier	SONOMA	310N	186860	Apr. 23, 2013	1 Year

5.4. Test Results

Pass.

Please refer the following plot.

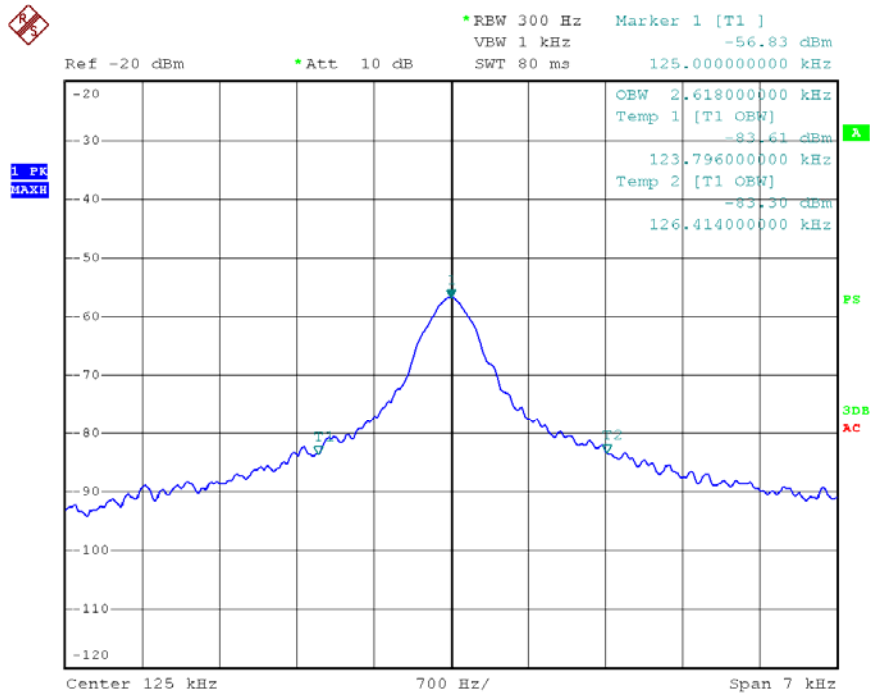

Date: 5.DEC.2013 13:50:59

6. TEST SETUP PHOTOGRAPH

6.1. Photo of Conducted Emission Measurement



6.2. Photo of Radiation Emission Test

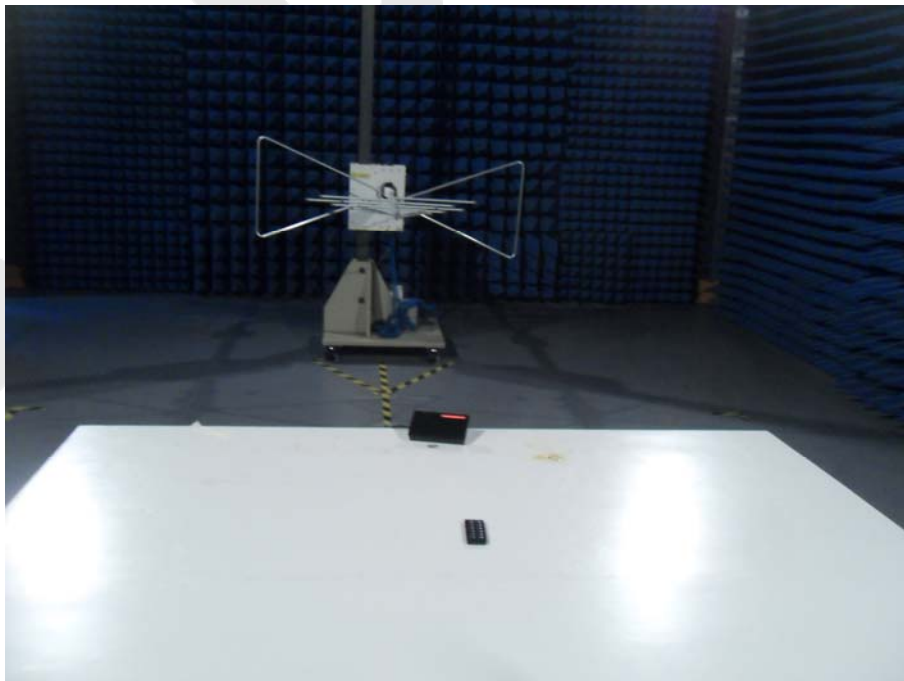

APPENDIX I (External Photos)

Figure 1

The EUT-Front View



Figure 2

The EUT-Front View

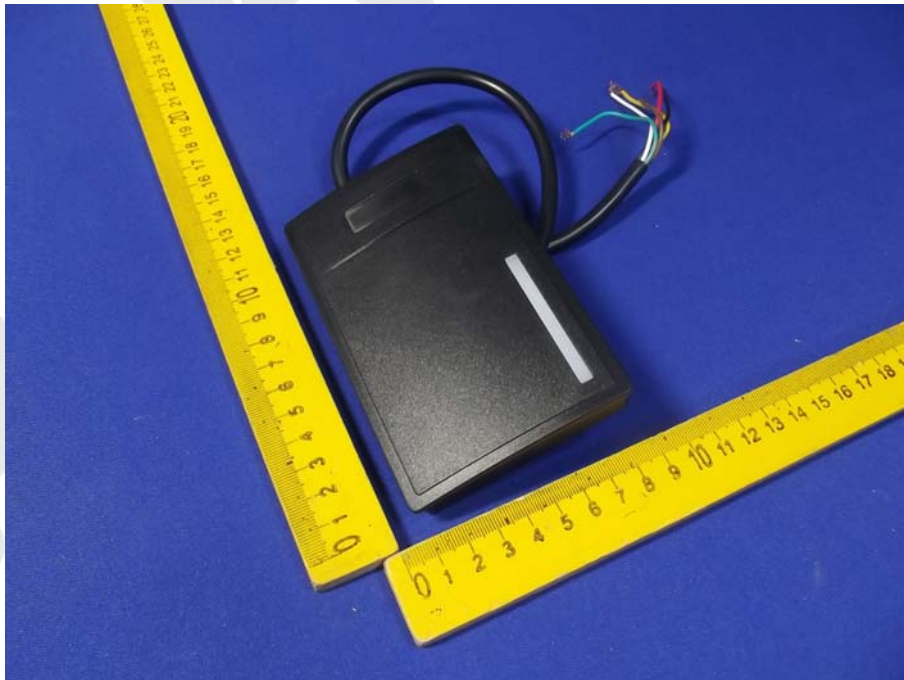
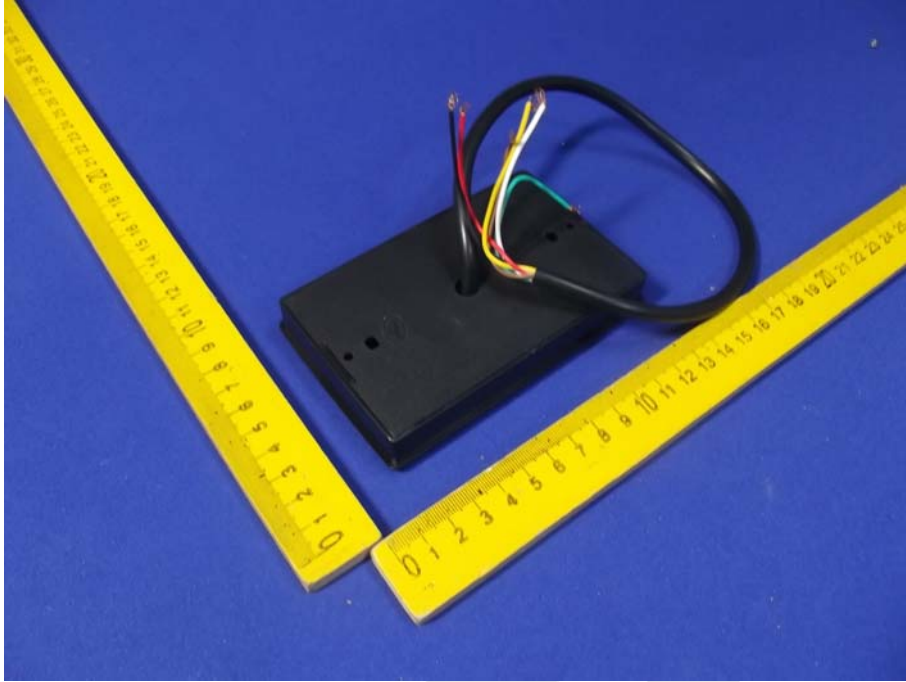

Figure 3
The EUT-Back View



APPENDIX II (Internal Photos)

Figure 4
The EUT-Inside View



Figure 5
PCB of the EUT-Front View

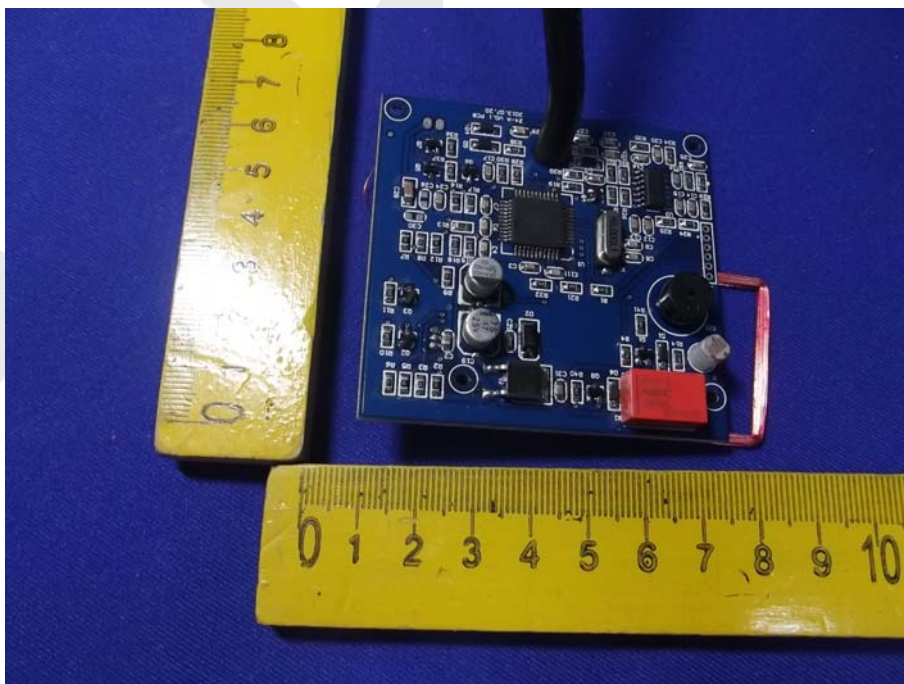

Figure 6
PCB of the EUT-Back View

