



EMC TEST REPORT for Intentional Radiator
No. 141201503SHA-001

Applicant : RAE Systems Inc.
3775 N. 1st St., San Jose, California USA 95134
Manufacturer : RAE Systems Inc.
3775 N. 1st St., San Jose, California USA 95134
Product Name : RAE WIFI Module
Type/Model : RMWIFI

SUMMARY

The equipment complies with the requirements according to the following standard(s):

47CFR Part 15 (2014): Radio Frequency Devices (Subpart C)

ANSI C63.4 (2009): American National Standard for Methods of Measurement of Radio-Noise Emissions from Low-Voltage Electrical and Electronic Equipment in the Range of 9 kHz to 40 GHz

Date of issue: March 2, 2015

Prepared by:

Nemo Li (*Project Engineer*)

Reviewed by:

Daniel Zhao (*Reviewer*)



Description of Test Facility

Name: Intertek Testing Services Limited Shanghai
Address: Building 86, No. 1198 Qinzhou Rd., North, Shanghai 200233, P.R. China

FCC Registration Number: 236597
IC Assigned Code: 2042B-1

Name of contact: Jonny Jing
Tel: +86 21 61278271
Fax: +86 21 54262353

Content

SUMMARY	1
DESCRIPTION OF TEST FACILITY	2
1. GENERAL INFORMATION	4
1.1 Applicant Information.....	4
1.2 Identification of the EUT	4
1.3 Technical specification	5
2. TEST SPECIFICATION	6
2.1 Instrument list	6
2.2 Test Standard	7
2.3 Mode of operation during the test / Test peripherals used.....	8
2.4 Test Summary	9
3. MINIMUM 6dB BANDWIDTH	10
3.1 Limit.....	10
3.2 Test Configuration	10
3.3 Test Procedure and test setup.....	10
4. MAXIMUM PEAK OUTPUT POWER	13
4.1 Test limit	13
4.2 Test Configuration	13
4.3 Test procedure and test setup.....	13
4.4 Test protocol	14
5. POWER SPECTRUM DENSITY	15
5.1 Test limit	15
5.2 Test Configuration	15
5.3 Test procedure and test setup.....	15
5.4 Test Protocol	16
6. RADIATED EMISSION IN THE RESTRICTED BANDS	18
6.1 Test limit	18
6.2 Test Configuration	18
6.3 Test procedure and test setup.....	19
6.4 Test protocol	20
7. EMISSION OUTSIDE THE FREQUENCY BAND	23
7.1 Limit.....	23
7.2 Test Configuration	23
7.3 Test procedure and test setup.....	23
7.4 Test protocol	25
8. POWER LINE CONDUCTED EMISSION	32
8.1 Limit.....	32
8.2 Test configuration	32
8.3 Test procedure and test set up.....	33
8.4 Test protocol	34



1. General Information

1.1 Applicant Information

Applicant : RAE Systems Inc.

3775 N. 1st St., San Jose, California USA 95134

Name of contact : James Liu

Tel : 408-5853672

Fax : 408-752-0724

Email : jliu@raesystems.com

Manufacturer : RAE Systems Inc.

3775 N. 1st St., San Jose, California USA 95134

1.2 Identification of the EUT

Product Name : RAE WIFI Module

Type/model : RMWIFI

FCC ID : SU3RMWIFI



1.3 Technical specification

Operation Frequency : 2412~2462 MHz
Band

Type of Modulation : CCK,BPSK,QPSK

EUT Modes of : 802.11b
Modulation

Channel Number : 11Channels for 2412MHz~2462MHz

Description of EUT : The EUT is a WIFI Module and has only one model.

Antenna : 1. Pole antenna
Model: 550-7032-000
Gain: 1.5dBi
2. PCB antenna
Model: M01-1104-000
Gain: 0dBi

Cable loss between : 0.5dB
antenna and PCB
board

Rating : 3.3V DC

Category of EUT : Class B

EUT type : Table top Floor standing

Sample received date : December 22, 2014

Sample Identification : /
No

Date of test : December 22, 2014 – February 13, 2014

2. Test Specification

2.1 Instrument list

Equipment	Type	Manu.	Internal no.	Cal. Date	Due date
Test Receiver	ESCS 30	R&S	EC 2107	2014-10-21	2015-10-20
Test Receiver	ESIB 26	R&S	EC 3045	2014-10-20	2015-10-19
Test Receiver	ESCI 7	R&S	EC4501	2014-12-29	2015-12-28
Spectrum Analyzer	N9010	Agilent	EC4890	2014-10-21	2015-10-20
Spectrum Analyzer	E4446	Agilent	/	2014-10-21	2015-10-20
Power meter	ML 2495A	Anritsu	EC 4895	2014-10-21	2015-10-20
A.M.N.	ESH2-Z5	R&S	EC 3119	2015-1-9	2016-1-8
Bilog Antenna	CBL 6112D	TESEQ	EC 4206	2014-5-15	2015-5-14
Horn antenna	HF 906	R&S	EC 3049	2014-5-12	2015-5-11
Pre-amplifier	Pre-amp 18	R&S	EC 3222	2014-4-11	2015-4-10
Pre-amplifier	Tpa0118-40	R&S	EC 4792-2	2014-4-11	2015-4-10
Log-period antenna	AT 1080	AR	EC 3044-7	2014-5-21	2015-5-20
Biconical antenna	3109PX	ETS	EC3564	2014-8-25	2015-8-24
Semi-anechoic chamber	-	Albatross project	EC 3048	2014-5-20	2015-5-19
Shielded room	-	Zhongyu	EC 2838	2015-1-12	2016-1-11
Shielded room	-	Zhongyu	EC 2839	2015-1-12	2016-1-11
High Pass Filter	WHKX 1.0/15G-10SS	Wainwright	EC4297-1	2014-2-1	2015-1-31
High Pass Filter	WHKX 2.8/18G-12SS	Wainwright	EC4297-2	2014-2-1	2015-1-31
High Pass Filter	WHKX 7.0/1.8G-8SS	Wainwright	EC4297-3	2014-2-1	2015-1-31
Band Reject Filter	WRCGV 2400/2483- 2390/2493- 35/10SS	Wainwright	EC4297-4	2014-2-1	2015-1-31
MXG Analog Signal Generator	N5181A	KEYSIGHT	EC5338-2	2014-11-7	2015-11-6
MXG Vector Signal Generator	N51812B	KEYSIGHT	EC5175	2014-12-30	2015-12-29
Power sensor	U2021XA	KEYSIGHT	EC5338-1	2014-10-2	2015-10-1
PXA Signal Analyzer	N9030A	KEYSIGHT	EC5338	2014-11-18	2015-11-17



2.2 Test Standard

47CFR Part 15 (2014)

ANSI C63.4 (2009)

KDB 558074 (V03R02)

2.3 Mode of operation during the test / Test peripherals used

While testing transmitting mode of EUT, the engineering mode was applied and continuously transmission was applied.

The lowest, middle and highest channel were tested as representatives.

Freq. Band	Modulation	Lowest(MHz)	Middle(MHz)	Highest(MHz)
2412-2462MHz	802.11b	2412	2437	2462

Test software:

EUT was tested with software SSCOM32 provided by the customer. EUT was connected and controlled by the EVB board which was connected to the computer by USB cable.

Data rate VS Power

The pre-scan for the conducted power with all rates in each modulation and bands was used, and the worst case was found and used in all test cases.

After this pre-scan, we choose the following table of the data rate as the worst case.

Freq. Band	Modulation	Worst case data rate
2400-2483.5MHz	802.11b	1Mbps

Duty cycle:

Mode	Duty cycle(x)	Duty cycle factor (dB)
802.11b	1.00	0.00

Test peripherals used:

Item No	Name	Band and Model	Description	S/N
1	Laptop computer	HP ProBook 6470b	100-240V AC, 50/60Hz	-
2	USB Cable	-	-	-
3	EVB Board	D01-1008-000 Rev2	-	-

2.4 Test Summary

This report applies to tested sample only. This report shall not be reproduced in part without written approval of Intertek Testing Service Shanghai Limited.

TEST ITEM	FCC REFERANCE	RESULT
Minimum 6dB Bandwidth	15.247(a)(2)	Pass
Maximum peak output power	15.247(b)	Pass
Power spectrum density	15.247(e)	Pass
Radiated emission	15.205 & 15.209	Pass
Emission outside the frequency band	15.247(d)	Pass
Power line conducted emission	15.207	Pass

3. Minimum 6dB Bandwidth

Test result: PASS

3.1 Limit

For systems using digital modulation techniques that may operate in the 902 - 928 MHz, 2400 - 2483.5 MHz and 5725 - 5850 MHz bands, the minimum 6 dB bandwidth shall be at least 500 kHz.

3.2 Test Configuration

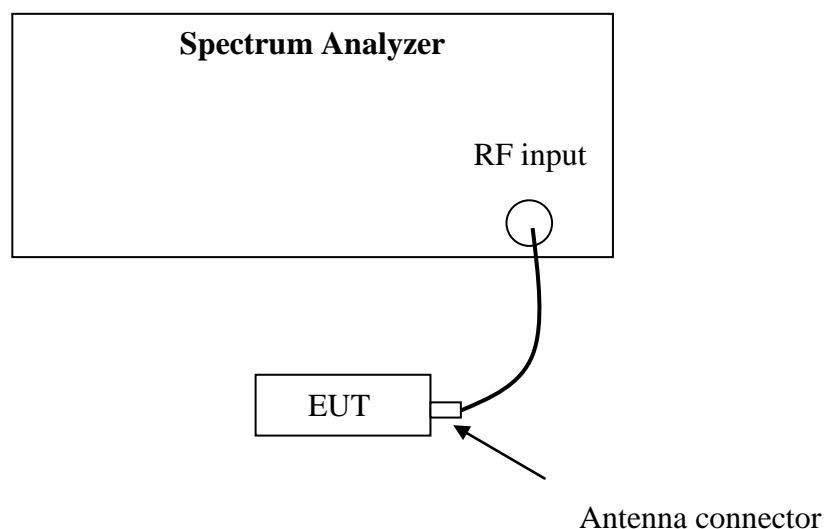

3.3 Test Procedure and test setup

The minimum 6dB bandwidth per FCC §15.247(a)(2) is measured using the Spectrum Analyzer according to DTS test procedure of “KDB558074 D01 DTS Meas Guidance v03r02” for compliance to FCC 47CFR 15.247 requirements (clause 8.2).

- a) Set RBW = 100 kHz.
- b) Set the video bandwidth (VBW) $\geq 3 \times$ RBW.
- c) Detector = Peak.
- d) Trace mode = max hold.
- e) Sweep = auto couple.
- f) Allow the trace to stabilize.
- g) Measure the maximum width of the emission that is constrained by the frequencies associated with the two outermost amplitude points (upper and lower frequencies) that are attenuated by 6 dB relative to the maximum level measured in the fundamental emission.

3.4 Test Protocol

Temperature : 25°C
 Relative Humidity : 55%

Mode	Channel	6dB Bandwidth (MHz)	Limit (MHz)
802.11b	L	9.60	≥0.5
	M	9.54	
	H	9.60	

Channel L – 6dB Bandwidth

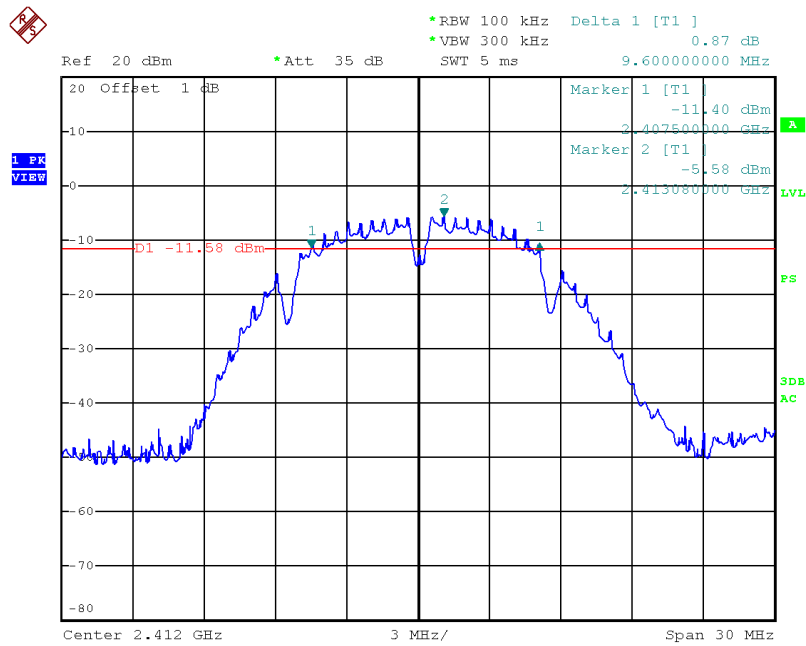

Date: 20.JAN.2015 14:44:16

Channel M – 6dB Bandwidth

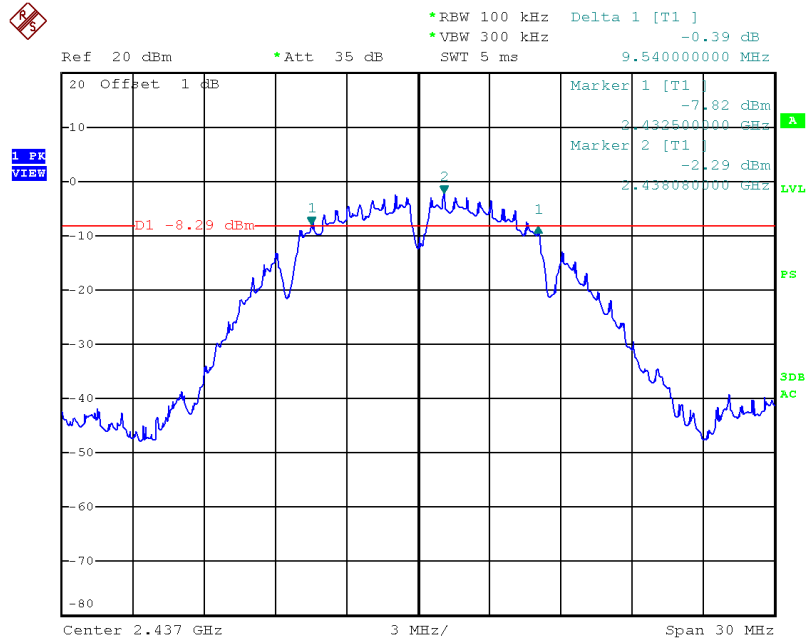

Date: 20.JAN.2015 14:46:05

Channel H – 6dB Bandwidth

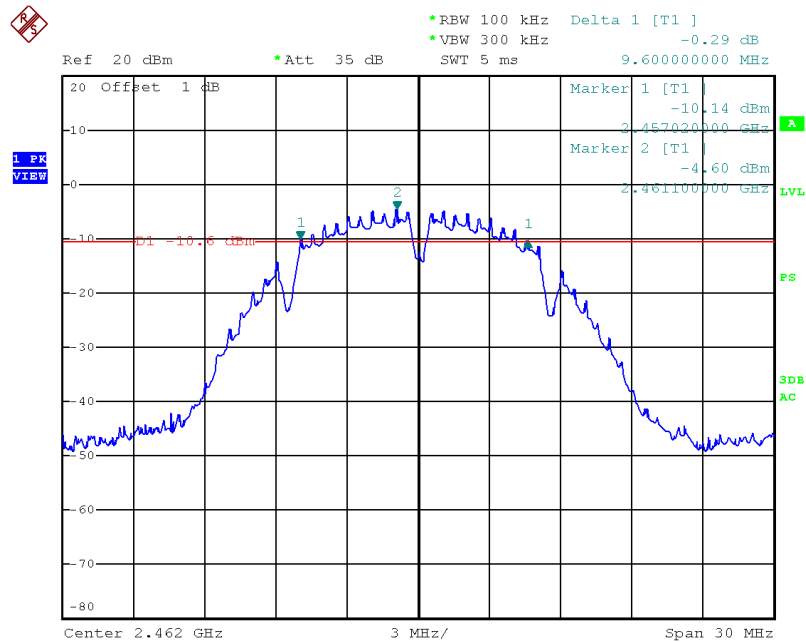

Date: 20.JAN.2015 14:48:14

4. Maximum peak output power

Test result: Pass

4.1 Test limit

- For frequency hopping systems operating in the 2400-2483.5 MHz band employing at least 75 non-overlapping hopping channels, and all frequency hopping systems in the 5725-5850 MHz band: 1 watt
- For all other frequency hopping systems in the 2400-2483.5 MHz band: 0.125 watts
- For systems using digital modulation in the 902-928 MHz, 2400-2483.5 MHz, and 5725-5850 MHz bands: 1 Watt

If the transmitting antenna of directional gain greater than 6dBi is used, the power shall be reduced by the amount in dB that the directional gain of the antenna exceeds 6dBi.

4.2 Test Configuration

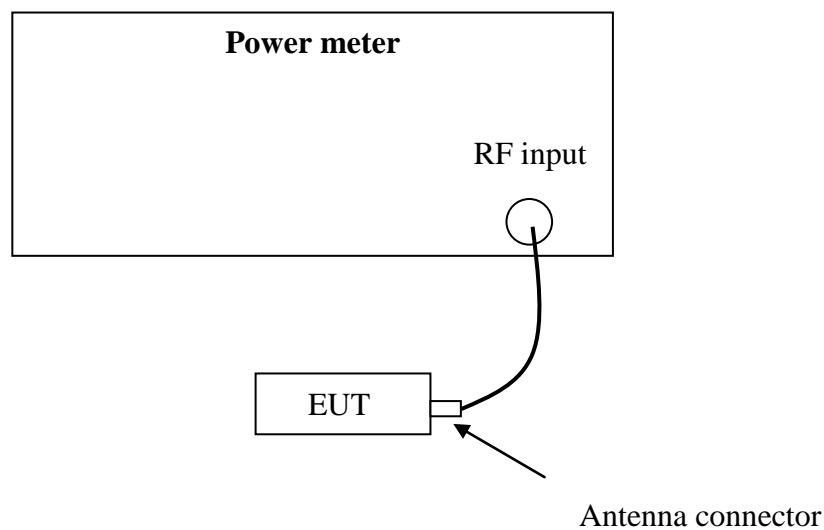

4.3 Test procedure and test setup

The EUT was tested according to DTS test procedure of “KDB558074 D01 DTS Meas Guidance v03r02” for compliance to FCC 47CFR 15.247 requirements (clause 9.1.2).

4.4 Test protocol

Temperature : 25°C
Relative Humidity : 55%

Mode	Channel	Cable loss	Peak power (dBm)	Limit (dBm)
802.11b	L	1.0	12.08	30.00
	M	1.0	12.33	30.00
	H	1.0	12.45	30.00

5. Power spectrum density

Test result: Pass

5.1 Test limit

For digitally modulated systems, the power spectral density conducted from the intentional radiator to the antenna shall not be greater than 8dBm in any 3 kHz band during any time interval of continuous transmission.

5.2 Test Configuration

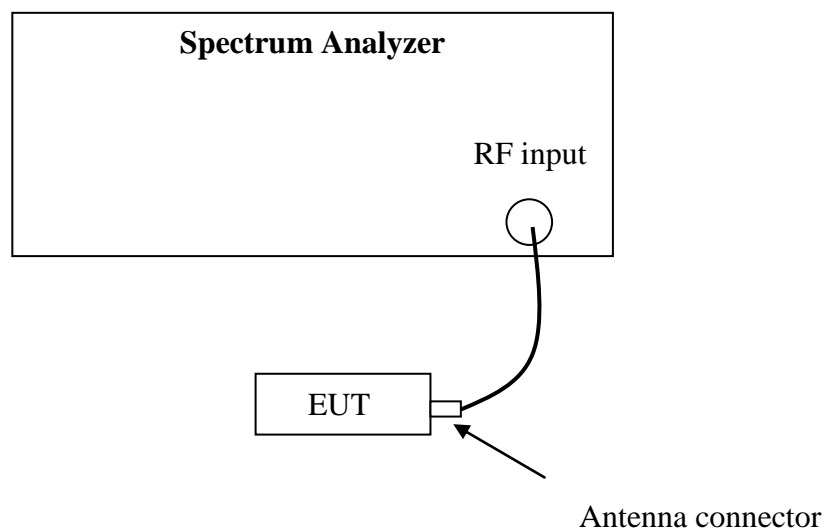

5.3 Test procedure and test setup

The power output per FCC §15.247(e) was tested according to DTS test procedure of “KDB558074 D01 DTS Meas Guidance v03r02” (clause 10.2) for compliance to FCC 47CFR 15.247 requirements.

- a) Set analyzer center frequency to DTS channel center frequency.
- b) Set the span to 1.5 times the *DTS bandwidth*.
- c) Set the RBW to: $3 \text{ kHz} \leq \text{RBW} \leq 100 \text{ kHz}$.
- d) Set the VBW $\geq 3 \times \text{RBW}$.
- e) Detector = peak.
- f) Sweep time = auto couple.
- g) Trace mode = max hold.
- h) Allow trace to fully stabilize.
- i) Use the peak marker function to determine the maximum amplitude level within the RBW.
- j) If measured value exceeds limit, reduce RBW (no less than 3 kHz) and repeat.

5.4 Test Protocol

Temperature : 25°C
 Relative Humidity : 55%

Mode	Channel	Factor	PSD (dBm/100kHz)	Limit (dBm/3kHz)
802.11b	L	1.0	-5.12	≤8.00
	M	1.0	-2.59	
	H	1.0	-4.84	

Channel L

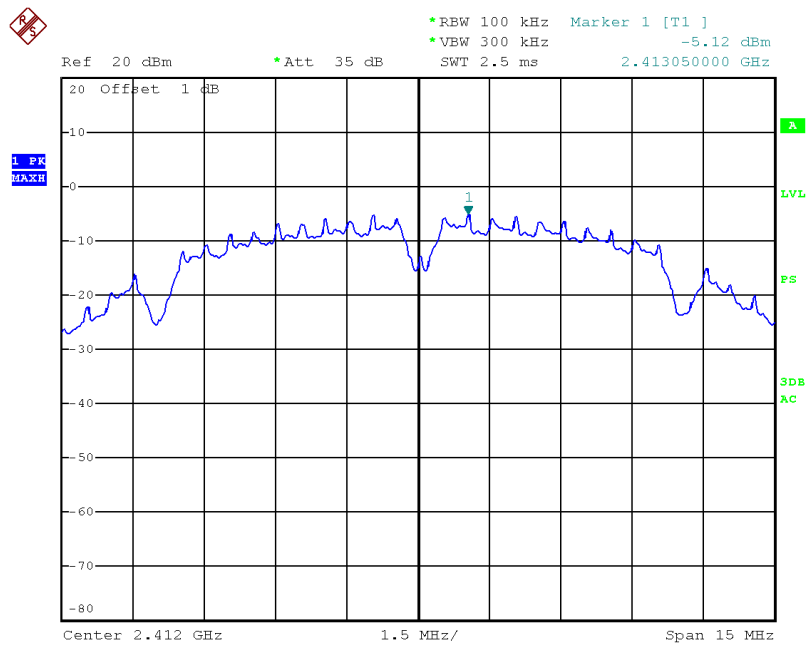

Date: 20.JAN.2015 14:57:59

Channel M

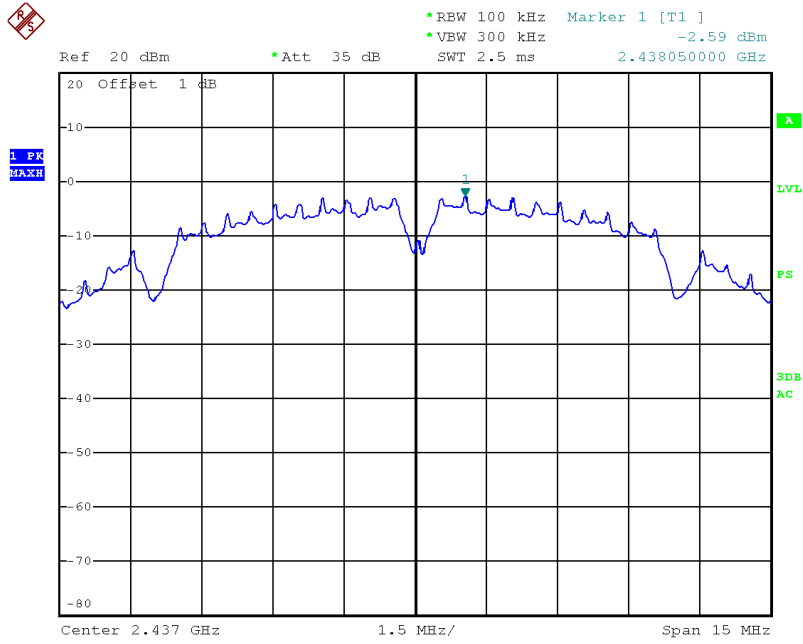

Date: 20.JAN.2015 14:59:02

Channel H

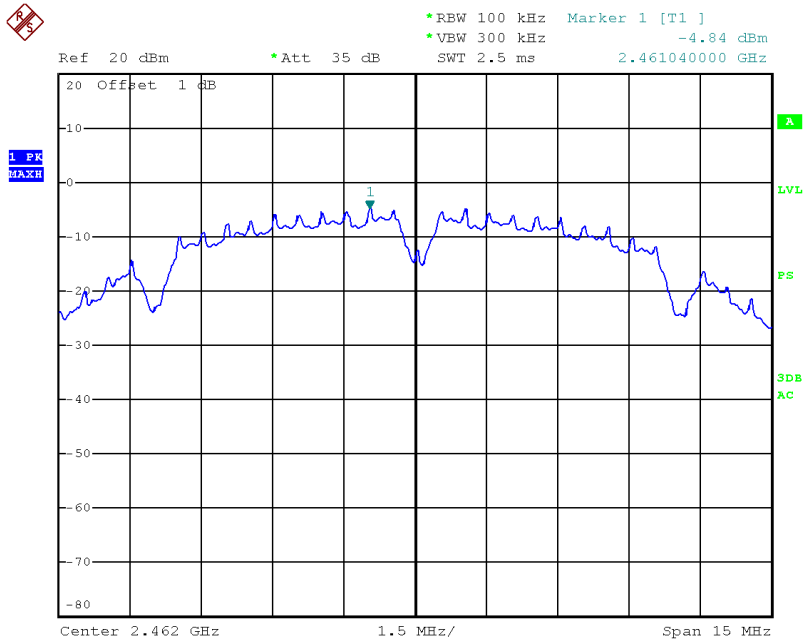

Date: 20.JAN.2015 15:00:40

6. Radiated emission in the restricted bands

Test result: **PASS**

6.1 Test limit

The radiated emissions which fall in the restricted bands, as defined in §15.205(a), must also comply with the radiated emission limits specified in §15.209(a) showed as below:

Frequency (MHz)	Field Strength (dBuV/m)	Measurement Distance (m)
30 - 88	40.0	3
88 - 216	43.5	3
216 - 960	46.0	3
Above 960	54.0	3

6.2 Test Configuration

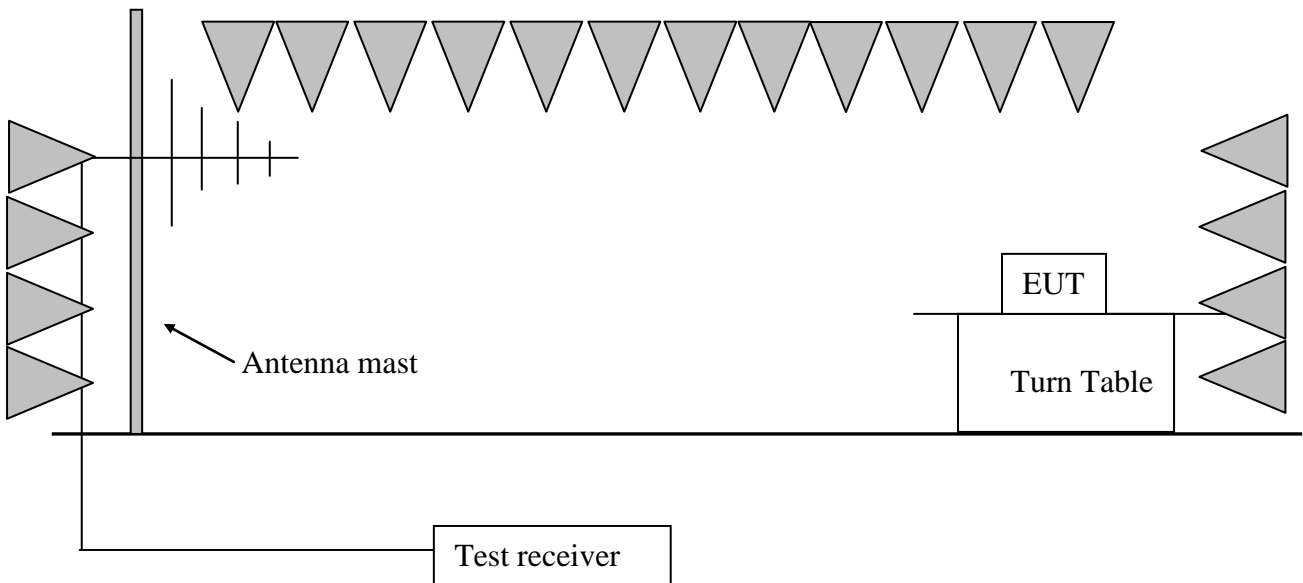

6.3 Test procedure and test setup

The measurement was applied in a semi-anechoic chamber. While testing for spurious emission higher than 1GHz, if applied, the pre-amplifier would be equipped just at the output terminal of the antenna.

The EUT and simulators were placed on a 0.8m high wooden turntable above the horizontal metal ground plane. The turn table rotated 360 degrees to determine the position of the maximum emission level. The EUT was set 3 meters away from the receiving antenna which was mounted on an antenna mast. The antenna moved up and down between from 1meter to 4 meters to find out the maximum emission level.

The EUT was tested according to DTS test procedure of KDB558074 D01 DTS “Meas Guidance v03r02” (clause 12) for compliance to FCC 47CFR 15.247 requirements.

6.4 Test protocol

Temperature : 25°C
 Relative Humidity : 55%

Test data:

Pole antenna

CH	Antenna	Frequency (MHz)	Corrected Reading (dBuV/m)	Correct Factor (dB/m)	Limit (dBuV/m)	Margin (dB)	Detector
L	H	2412.60	102.10	34.10	Fundamental	/	PK
	H	276.25	39.40	14.60	46.00	6.60	QP
	H	299.70	37.40	15.40	46.00	8.60	QP
	H	345.20	35.90	16.60	46.00	10.10	QP
	V	276.25	36.00	14.60	43.50	7.50	QP
	V	345.20	39.00	16.60	46.00	7.00	QP
	H	2389.36	61.76	34.20	74.00	12.24	PK
	H	2389.36	38.74	34.20	54.00	15.26	AV
	H	4824.05	51.30	-3.60	74.00	22.70	PK
M	H	2437.55	102.25	34.20	Fundamental	/	PK
	H	276.25	39.40	14.60	46.00	6.60	QP
	H	299.70	37.40	15.40	46.00	8.60	QP
	H	345.20	35.90	16.60	46.00	10.10	QP
	V	276.25	36.00	14.60	43.50	7.50	QP
	V	345.20	39.00	16.60	46.00	7.00	QP
	H	4874.16	52.50	-3.50	74.00	21.50	PK
H	H	2462.90	102.48	34.40	Fundamental	/	PK
	H	276.25	39.40	14.60	46.00	6.60	QP
	H	299.70	37.40	15.40	46.00	8.60	QP
	H	345.20	35.90	16.60	46.00	10.10	QP
	V	276.25	36.00	14.60	43.50	7.50	QP
	V	345.20	39.00	16.60	46.00	7.00	QP
	H	2488.70	65.49	34.80	74.00	8.51	PK
	H	2488.70	37.50	34.80	54.00	16.50	AV
	H	4924.14	51.90	-3.30	74.00	22.10	PK

PCB antenna

The antenna was placed with three axis(X, Y, Z) and the worst data was listed in the report.

CH	Antenna	Frequency (MHz)	Corrected Reading (dBuV/m)	Correct Factor (dB/m)	Limit (dBuV/m)	Margin (dB)	Detector
L	H	2412.60	99.13	34.10	Fundamental	/	PK
	H	276.25	39.40	14.60	46.00	6.60	QP
	H	299.70	37.40	15.40	46.00	8.60	QP
	H	345.20	35.90	16.60	46.00	10.10	QP
	V	276.25	36.00	14.60	43.50	7.50	QP
	V	345.20	39.00	16.60	46.00	7.00	QP
	H	2389.52	57.96	34.20	74.00	16.04	PK
	H	2389.52	37.45	34.20	54.00	16.55	AV
	H	4824.05	48.50	-3.60	74.00	25.50	PK
M	H	2437.55	99.34	34.20	Fundamental	/	PK
	H	276.25	39.40	14.60	46.00	6.60	QP
	H	299.70	37.40	15.40	46.00	8.60	QP
	H	345.20	35.90	16.60	46.00	10.10	QP
	V	276.25	36.00	14.60	43.50	7.50	QP
	V	345.20	39.00	16.60	46.00	7.00	QP
	H	4874.16	48.90	-3.50	74.00	25.10	PK
H	H	2462.90	99.59	34.40	Fundamental	/	PK
	H	276.25	39.40	14.60	46.00	6.60	QP
	H	299.70	37.40	15.40	46.00	8.60	QP
	H	345.20	35.90	16.60	46.00	10.10	QP
	V	276.25	36.00	14.60	43.50	7.50	QP
	V	345.20	39.00	16.60	46.00	7.00	QP
	H	2483.97	59.31	34.80	74.00	14.69	PK
	H	2483.97	37.62	34.80	54.00	16.38	AV
	H	4924.05	49.60	-3.30	74.00	24.40	PK

Remark:

1. Factor= Antenna Factor + Cable Loss (-Amplifier, is employed)
2. Measure level= Reading level + Factor
3. Over Limit = Limit – Measure level
4. If the PK measured level is lower than AV limit, the AV test can be elided.

Example:

Assuming Antenna Factor = 30.20dB/m, Cable Loss = 2.00dB,

Gain of Preamplifier = 32.00dB, Original Receiver Reading level = 10dBuV.

Then Factor = 30.20 + 2.00 – 32.00 = 0.20dB/m;

Measure level = 10dBuV + 0.20dB/m = 10.20dBuV/m

Assuming limit = 54dBuV/m, Measure level = 10.20dBuV/m,

then Over Limit = 10.20 - 54= -43.80dBuV/m

7. Emission outside the frequency Band

Test result: **PASS**

7.1 Limit

In any 100 kHz bandwidth outside the frequency band in which the spread spectrum intentional radiator is operating, the radio frequency power that is produced by the intentional radiator shall be at least 20 dB below that in the 100 kHz bandwidth within the band that contains the highest level of the desired power.

7.2 Test Configuration

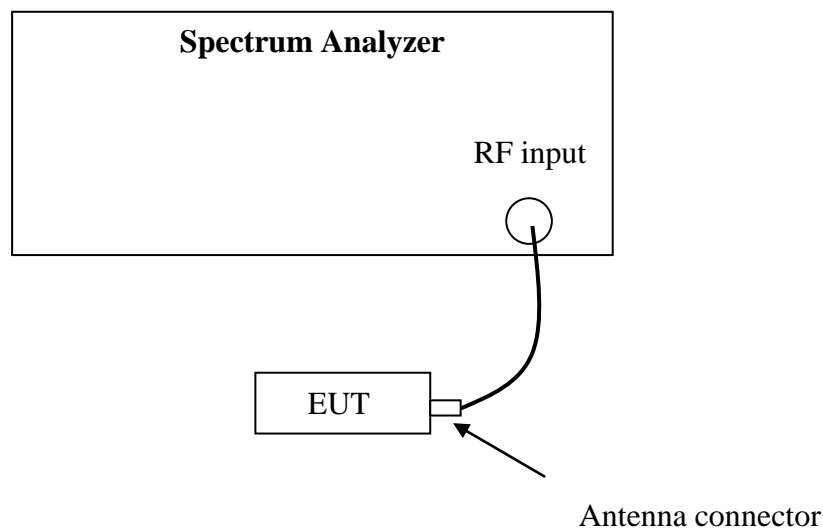

7.3 Test procedure and test setup

The EUT was tested according to DTS test procedure of “KDB558074 D01 DTS Meas Guidance v03r02” (clause 11.0) for compliance to FCC 47CFR 15.247 requirements.

Reference level measurement

Establish a reference level by using the following procedure:

- a) Set instrument center frequency to DTS channel center frequency.
- b) Set the span to ≥ 1.5 times the *DTS bandwidth*.
- c) Set the RBW = 100 kHz.
- d) Set the VBW $\geq 3 \times$ RBW.
- e) Detector = peak.
- f) Sweep time = auto couple.
- g) Trace mode = max hold.
- h) Allow trace to fully stabilize.
- i) Use the peak marker function to determine the maximum PSD level.

Note that the channel found to contain the maximum PSD level can be used to establish the reference level.

Emission level measurement

- a) Set the center frequency and span to encompass frequency range to be measured.
- b) Set the RBW = 100 kHz.
- c) Set the VBW $\geq 3 \times$ RBW.
- d) Detector = peak.
- e) Sweep time = auto couple.
- f) Trace mode = max hold.
- g) Allow trace to fully stabilize.
- h) Use the peak marker function to determine the maximum amplitude level.

Ensure that the amplitude of all unwanted emissions outside of the authorized frequency band (excluding restricted frequency bands) are attenuated by at least the minimum requirements specified in 11.1 a) or 11.1 b). Report the three highest emissions relative to the limit.

7.4 Test protocol

Temperature : 25 °C
 Relative Humidity : 55 %

Mode	Channel	Max PSD among band (dBm)	The most restrict Attenuation outside band (dB)	Limit (dB)
802.11b	L	-5.12	41.92	≥20
	M	-2.75	44.75	
	H	-4.84	41.71	

Channel L - 1MHz ~ 2.3GHz

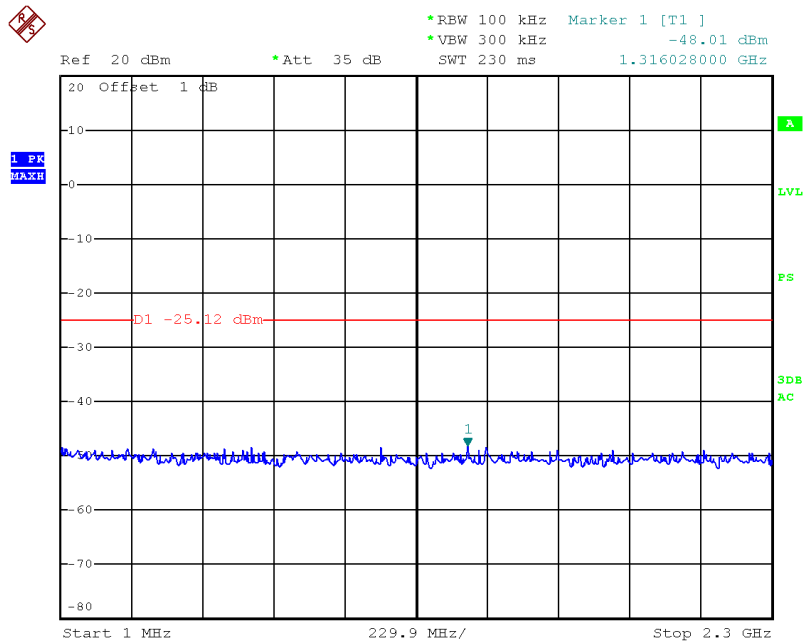

Date: 20.JAN.2015 15:07:54

Channel L – 2.3GHz ~ 2.5GHz

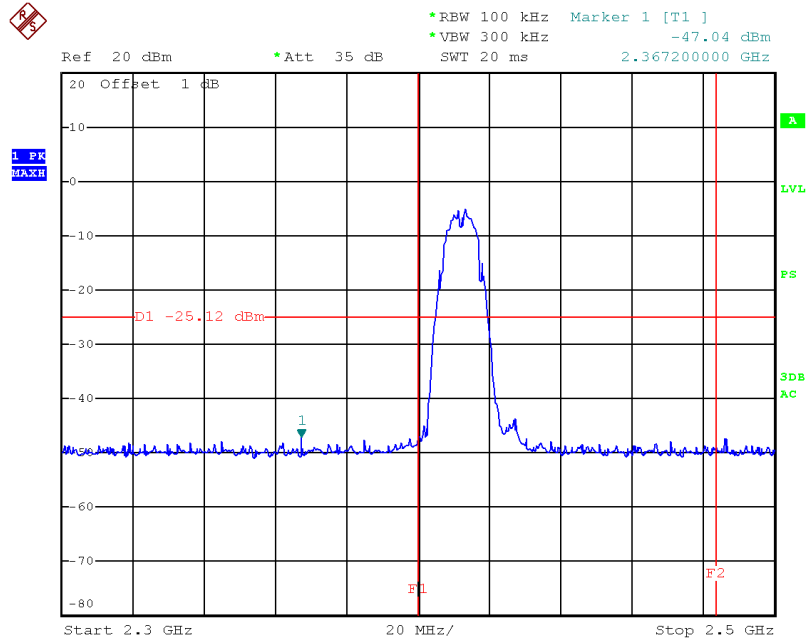

Date: 20.JAN.2015 15:09:01

Channel L – 2.5GHz ~ 7GHz

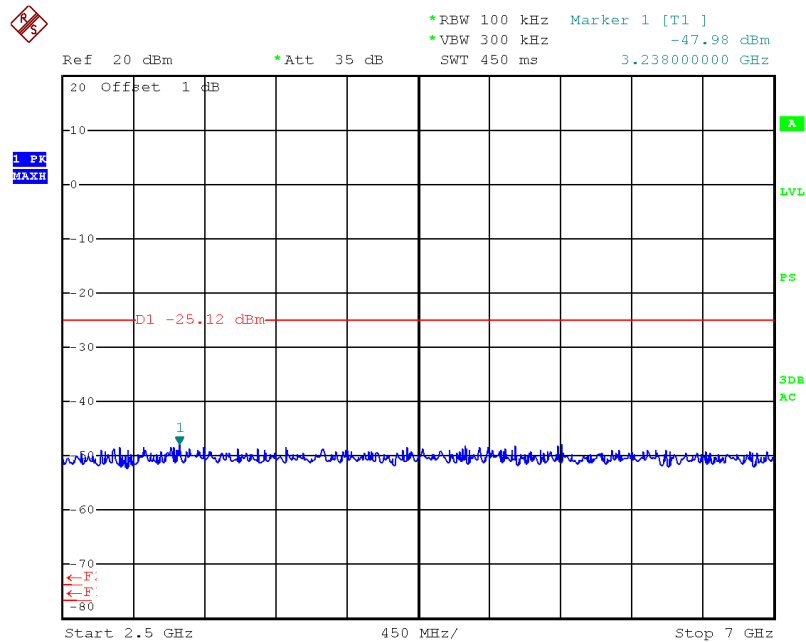

Date: 20.JAN.2015 15:09:31

Channel L – 7GHz ~ 25GHz



Channel M - 1MHz ~ 2.3GHz

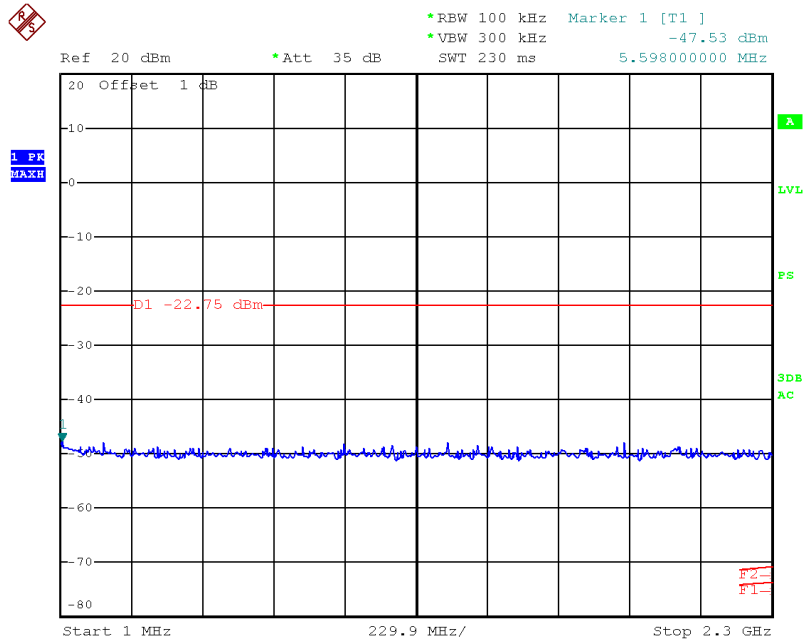

Date: 20.JAN.2015 15:10:39

Channel M – 2.3GHz ~ 2.5GHz

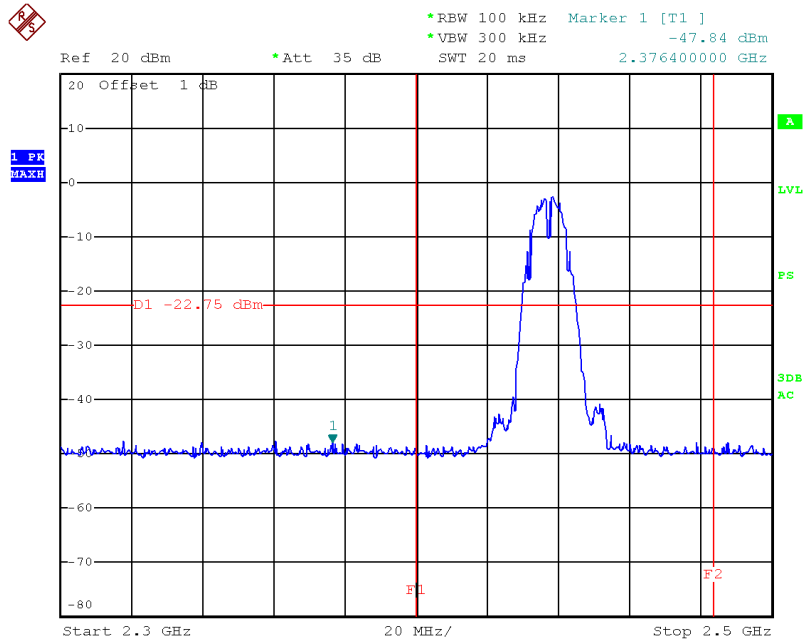

Date: 20.JAN.2015 15:11:37

Channel M – 2.5GHz ~ 7GHz

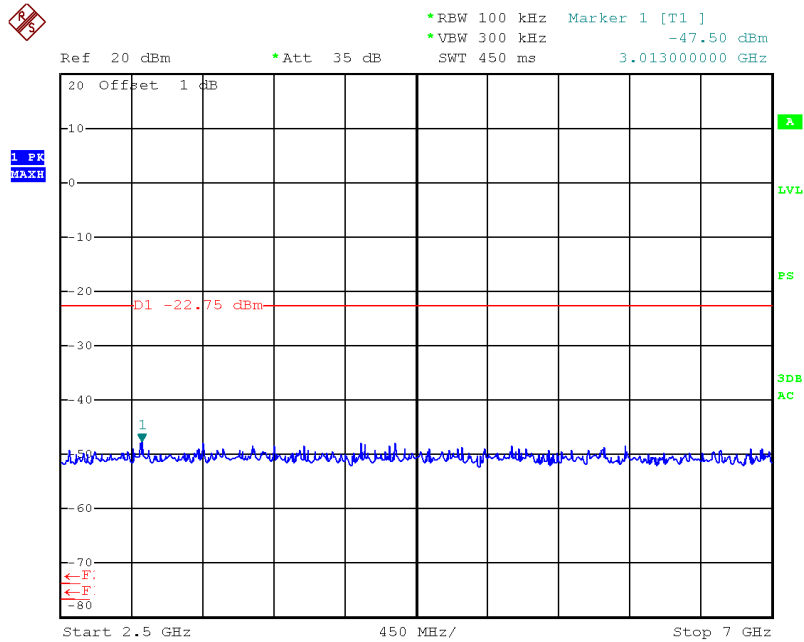

Date: 20.JAN.2015 15:12:03

Channel M – 7GHz ~ 25GHz



Channel H - 1MHz ~ 2.3GHz

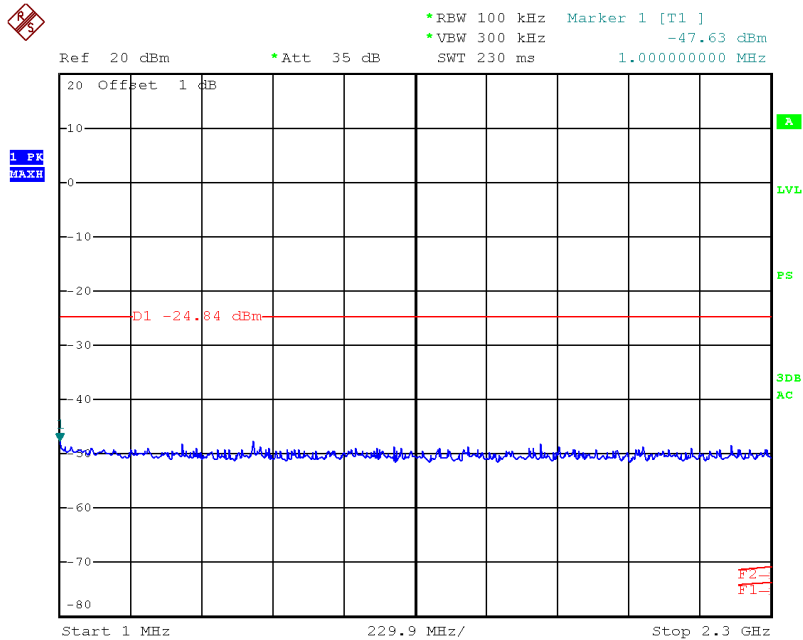

Date: 20.JAN.2015 15:12:59

Channel H – 2.3GHz ~ 2.5GHz

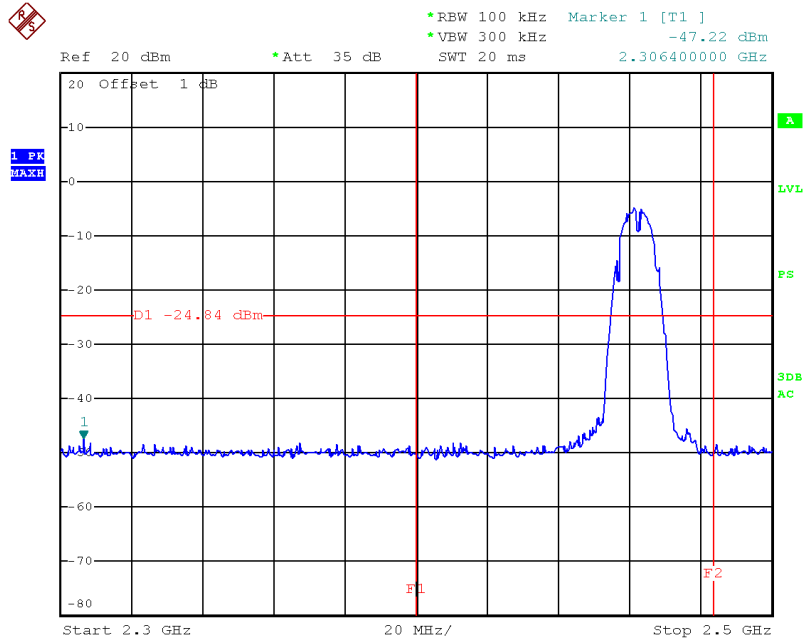

Date: 20.JAN.2015 15:13:48

Channel H – 2.5GHz ~ 7GHz

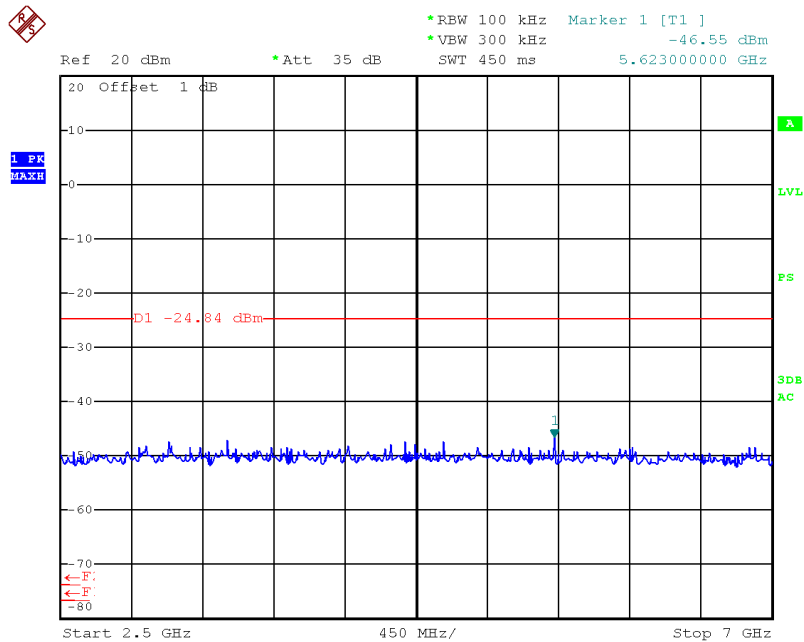

Date: 20.JAN.2015 15:14:15

Channel H – 7GHz ~ 25GHz

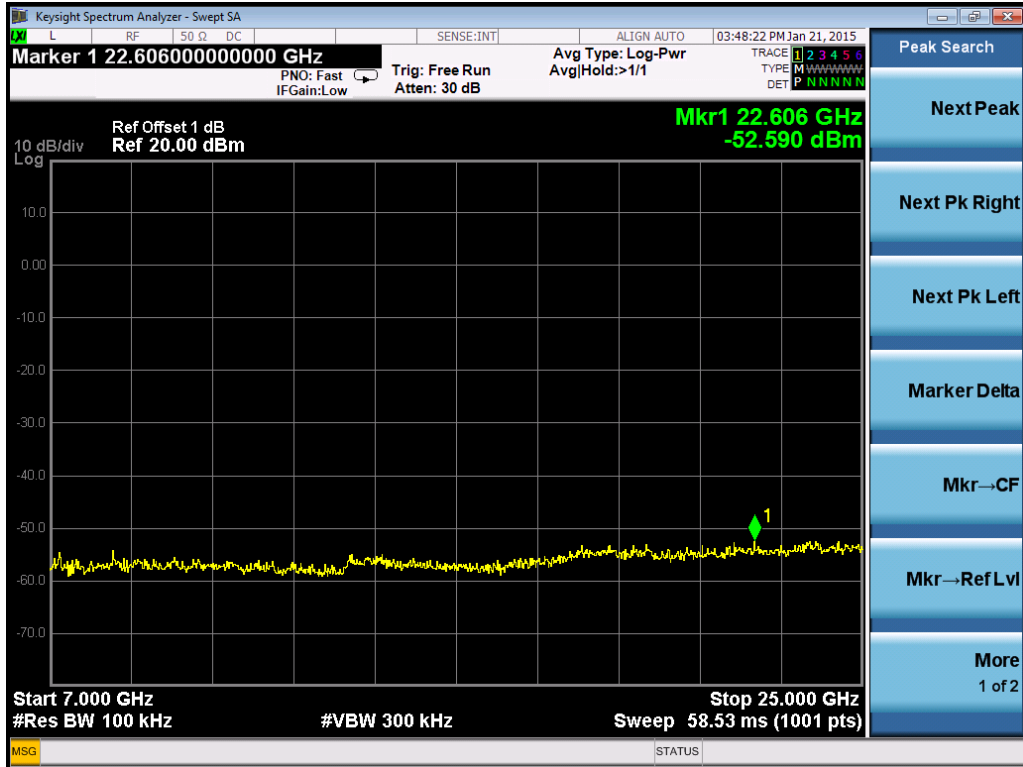

8. Power line conducted emission

Test result: Pass

8.1 Limit

Frequency of Emission (MHz)	Conducted Limit (dBuV)	
	QP	AV
0.15-0.5	66 to 56*	56 to 46 *
0.5-5	56	46
5-30	60	50

* Decreases with the logarithm of the frequency.

8.2 Test configuration

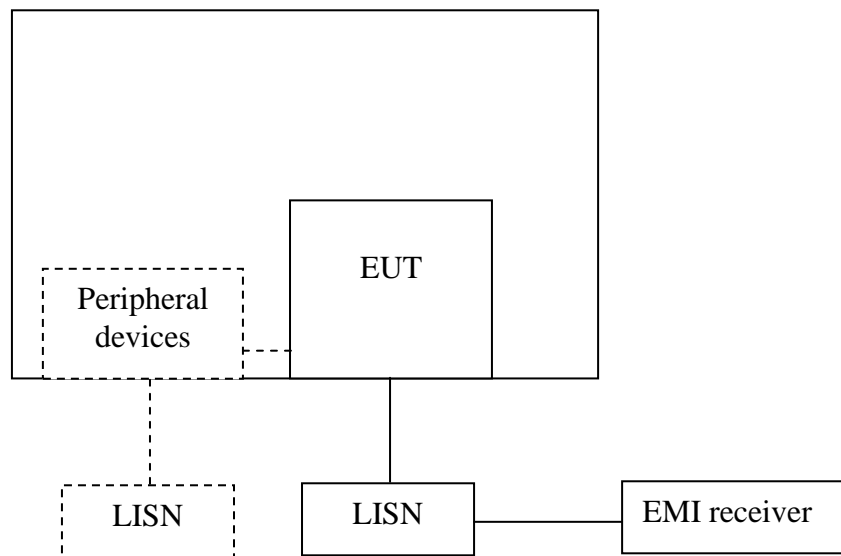

For table top equipment, wooden support is 0.8m height table

For floor standing equipment, wooden support is 0.1m height rack.

8.3 Test procedure and test set up

The EUT are connected to the main power through a line impedance stabilization network (LISN). This provides a $50\Omega/50\mu\text{H}$ coupling impedance for the measuring equipment. The peripheral devices are also connected to the main power through a LISN that provides a $50\Omega/50\mu\text{H}$ coupling impedance with 50Ω termination.

Both sides (Line and Neutral) of AC line are checked for maximum conducted interference. In order to find the maximum emission, the relative positions of equipment and all of the interface cables must be changed according to ANSI C63.4 on conducted measurement. The bandwidth of the test receiver is set at 9 kHz.

8.4 Test protocol

Temperature : 25°C
 Relative Humidity : 55%

L Line

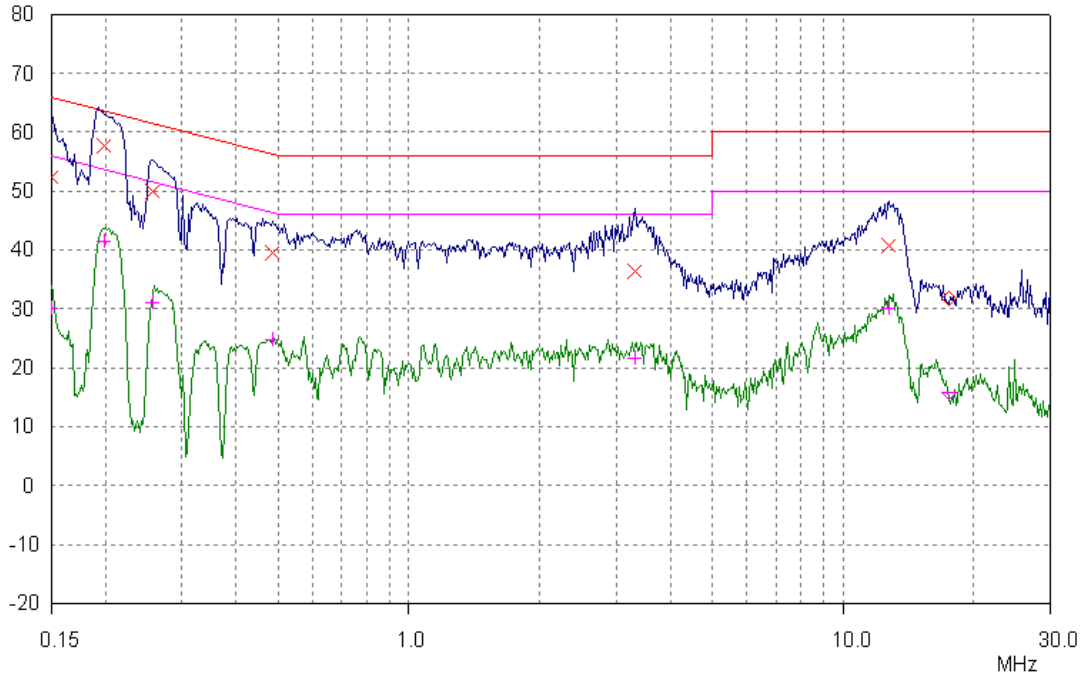

Test Data:

Frequency (MHz)	Quasi-peak			Average		
	level dB(µV)	Limit dB(µV)	Margin (dB)	level dB(µV)	limit dB(µV)	Margin (dB)
0.150	52.22	66.00	13.78	30.04	56.00	25.96
0.198	57.68	63.71	6.03	41.47	53.71	12.24
0.256	49.93	61.56	11.63	30.92	51.56	20.64
0.483	39.50	56.29	16.79	24.66	46.29	21.63
3.309	36.25	56.00	19.75	21.53	46.00	24.47
12.655	40.79	60.00	19.21	30.11	50.00	19.89

N Line

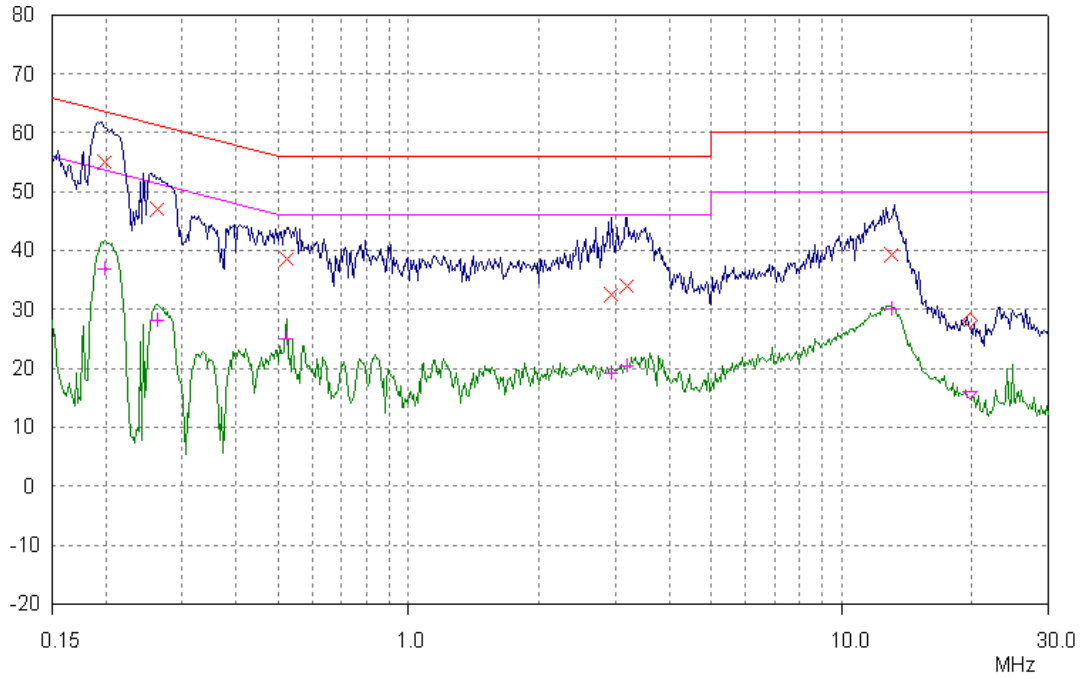

Test Data:

Frequency (MHz)	Quasi-peak			Average		
	level dB(μV)	Limit dB(μV)	Margin (dB)	level dB(μV)	limit dB(μV)	Margin (dB)
0.198	54.89	63.68	8.79	36.78	53.68	16.90
0.262	46.94	61.36	14.42	28.06	51.36	23.30
0.523	38.54	56.00	17.46	24.88	46.00	21.12
2.936	32.58	56.00	23.42	19.14	46.00	26.86
3.205	33.97	56.00	22.03	20.28	46.00	25.72
12.961	39.27	60.00	20.73	30.06	50.00	19.94