



EMC TEST REPORT for Intentional Radiator

No. SH11040699-001

Applicant : RAE Systems Inc.
3775 N. 1st St., San Jose, California USA 95134

Manufacturer : RAE Systems Inc.
3775 N. 1st St., San Jose, California USA 95134

Product Name : RAEMesh Radio

Type/Model : RM2400A

SUMMARY

The equipment complies with the requirements according to the following standard(s):

47CFR Part 15 (2009): Radio Frequency Devices

ANSIC63.4 (2003): American National Standard for Methods of Measurement of Radio-Noise Emissions from Low-Voltage Electrical and Electronic Equipment in the Range of 9 kHz to 40 GHz

RSS-210 Issue 8 (December 2010): Low-power Licence-exempt Radiocommunication Devices (All Frequency Bands): Category I Equipment

RSS-Gen Issue 3 (December 2010): General Requirements and Information for the Certification of Radiocommunication Equipment

RSS-310 Issue 3 (December 2010): Licence-exempt Radio Apparatus (All Frequency Bands): Category II Equipment

Date of issue: July 10, 2011

Prepared by:

Wakeyou Wang (*Project Engineer*)

Reviewed by:

Daniel Zhao (*Reviewer*)



Description of Test Facility

Name: Intertek Testing Services Ltd. Shanghai ETL Semko

Address: Building No.86, 1198 Qinzhou Road(North), Shanghai 200233, P.R. China

FCC Registration Number: 236597

IC Assigned Code: 2042B-1

Name of contact: Steve Li

Tel: +86 21 64956565 ext. 214

Fax: +86 21 54262335 ext. 214

Content

SUMMARY	1
DESCRIPTION OF TEST FACILITY.....	2
1. GENERAL INFORMATION.....	5
1.1 Applicant Information.....	5
1.2 Identification of the EUT	5
1.3 Technical specification.....	6
1.4 Mode of operation during the test / Test peripherals used	6
2. TEST SPECIFICATION.....	7
2.1 Instrument list.....	7
2.2 Test Standard.....	7
3. MINIMUM 6dB BANDWIDTH.....	9
3.1 Limit	9
3.2 Test Configuration	9
3.3 Test Procedure and test setup.....	9
3.4 Test Protocol	10
4. MAXIMUM PEAK OUTPUT POWER.....	11
4.1 Test limit.....	11
4.2 Test Configuration	11
4.3 Test procedure and test setup.....	11
4.4 Test protocol.....	12
5. POWER SPECTRUM DENSITY	13
5.1 Test limit.....	13
5.2 Test Configuration	13
5.3 Test procedure and test setup.....	13
5.4 Test Protocol	14
6. RADIATED EMISSION.....	15
6.1 Test limit.....	15
6.2 Test Configuration	15
6.3 Test procedure and test setup.....	16
6.4 Test protocol.....	17
7. EMISSION OUTSIDE THE FREQUENCY BAND.....	19
7.1 Limit	19
7.2 Test Configuration	19
7.3 Test procedure and test setup.....	19
7.4 Test protocol.....	20
8. POWER LINE CONDUCTED EMISSION	21
8.1 Limit	21
8.2 Test configuration	21
8.3 Test procedure and test set up.....	22
8.4 Test protocol.....	22
9. CHANNEL NUMBER OF HOPPING SYSTEM	23
9.1 Limit	23
9.2 Test Configuration	23
9.3 Test procedure and test setup.....	23
9.4 Test protocol.....	24



- 10. AVERAGE TIME OF OCCUPANCY IN ANY CHANNEL25**
 - 10.1 Limit25
 - 10.2 Test Configuration25
 - 10.3 Test procedure and test setup25
 - 10.4 Test protocol.....26
- 11. OCCUPIED BANDWIDTH.....27**
 - 11.1 Test limit.....27
 - 11.2 Test Configuration27
 - 11.3 Test procedure and test setup27
 - 11.4 Test protocol.....28
- 12. SPURIOUS EMISSION FOR RECEIVER.....29**
 - 12.1 Test limit.....29
 - 12.2 Test Configuration29
 - 12.3 Test procedure and test setup29
 - 12.4 Test protocol.....30



1. General Information

1.1 Applicant Information

Applicant: RAE Systems Inc.
3775 N. 1st St., San Jose, California USA 95134

Name of contact: James Liu

Tel: 408-5853672
Fax: 408-752-0724
Email: jliu@raesystems.com

Manufacturer: RAE Systems Inc.
3775 N. 1st St., San Jose, California USA 95134

Sample received date : May 22, 2011
Date of test : May 22, 2011 ~ July 5, 2011

1.2 Identification of the EUT

Equipment: RAEMesh Radio
Type/model: RM2400A
FCC ID: SU3RM2400A
IC: Not applied



1.3 Technical specification

Operation Frequency Band: 2405 – 2480 MHz
Modulation: O-QPSK
Antenna Designation: Omnidirectional antenna
Gain of Antenna: 3.5dBi max.
Rating: DC 3.3V powered by AC/DC adapter indirectly: input 100 - 240V~, 50/60Hz, 0.2A
Description of EUT: Here is one model only.
The EUT is a wireless module for data transmission.

Channel Description:

Channel Identifier	Frequency (MHz)	Channel Identifier	Frequency (MHz)
1	2405	9	2445
2	2410	10	2450
3	2415	11	2455
4	2420	12	2460
5	2425	13	2465
6	2430	14	2470
7	2435	15	2475
8	2440	16	2480

1.4 Mode of operation during the test / Test peripherals used

Within this test report, both transmitter and receiver mode of EUT were tested. While testing transmitter mode of EUT, the internal modulation was used. While testing receiver mode of EUT, the signal generator with a transmitting antenna generating 2.4GHz sine wave is put in close proximity to the EUT. For the EUT can be used in any axes as the user wants, it was set up in three axis (X, Y, Z) while the antenna always was kept vertically and performed test. The three axes were tested one by one while the test receiver worked as “max hold” continuously and the highest reading among the whole test procedure was recorded.

2. Test Specification

2.1 Instrument list

Equipment	Type	Manu.	Internal no.	Cal. Date	Due date
Test Receiver	ESIB 26	R&S	EC 3045	2010-10-22	2011-10-21
A.M.N.	ESH2-Z5	R&S	EC 3119	2011-1-10	2012-1-9
A.M.N.	ESH3-Z5	R&S	EC 2109	2011-1-10	2012-1-9
Horn antenna	HF 906	R&S	EC 3049	2011-5-13	2012-5-12
Pre-amplifier	Pre-amp 18	R&S	EC 3222	2010-9-18	2011-9-17
Signal generator	SMR 20	R&S	EC 3044-1	2010-8-17	2011-8-16
Semi-anechoic chamber	-	Albatross project	EC 3048	2011-5-21	2012-5-20
High Pass Filter	WHKX 1.0/15G-10SS	Wainwright	EC4297-1	2011-2-8	2012-2-7
High Pass Filter	WHKX 2.8/18G-12SS	Wainwright	EC4297-2	2011-2-8	2012-2-7
High Pass Filter	WHKX 7.0/1.8G-8SS	Wainwright	EC4297-3	2011-2-8	2012-2-7
Band Reject Filter	WRCGV 2400/2483-2390/2493-35/10SS	Wainwright	EC4297-4	2011-2-8	2012-2-7
Power sensor / Power meter	N1911A/N1921A	Agilent	EC4318	2011-04-11	2012-04-10
Spectrum analyzer	E7402A	Agilent	EC2254	2010-11-09	2011-11-08

2.2 Test Standard

47CFR Part 15 (2009)
 ANSI C63.4: 2003
 RSS-210 Issue 8 (December 2010)
 RSS-Gen Issue 3 (December 2010)
 RSS-310 Issue 3 (December 2010)

2.3 Test Summary

This report applies to tested sample only. This report shall not be reproduced in part without written approval of Intertek Testing Service Shanghai Limited.

TEST ITEM	FCC REFERENCE	IC REFERENCE	RESULT
Minimum 6dB Bandwidth	15.247(a)(2)	RSS-210 Issue 8 Annex 8	Pass
Maximum peak output power	15.247(b)	RSS-210 Issue 8 Annex 8	Pass
Power spectrum density	15.247(e)	RSS-210 Issue 8 Annex 8	Pass
Radiated emission	15.205 & 15.209	RSS-210 Issue 8 Clause 2	Pass
Emission outside the frequency band	15.247(d)	RSS-210 Issue 8 Annex 8	Pass
Power line conducted emission	15.207	RSS-Gen Issue 3 Clause 7.2.4	Pass
Channel number of hopping system	15.247(a)(1)(iii)	RSS-210 Issue 8 Annex 8	NA
Average time of occupancy in any channel	15.247(a)(1)(iii)	RSS-210 Issue 8 Annex 8	NA
Occupied bandwidth	-	RSS-Gen Issue 3 Clause 4.6.1	Tested
Spurious emission for receiver	-	RSS-310 Issue 3 Clause 3.1	Pass

2.4 Data rate VS power

The data rate of EUT is fixed and cannot be adjusted.

3. Minimum 6dB Bandwidth

Test result: PASS

3.1 Limit

For systems using digital modulation techniques that may operate in the 902 - 928 MHz, 2400 - 2483.5 MHz and 5725 - 5850 MHz bands, the minimum 6 dB bandwidth shall be at least 500 kHz.

3.2 Test Configuration

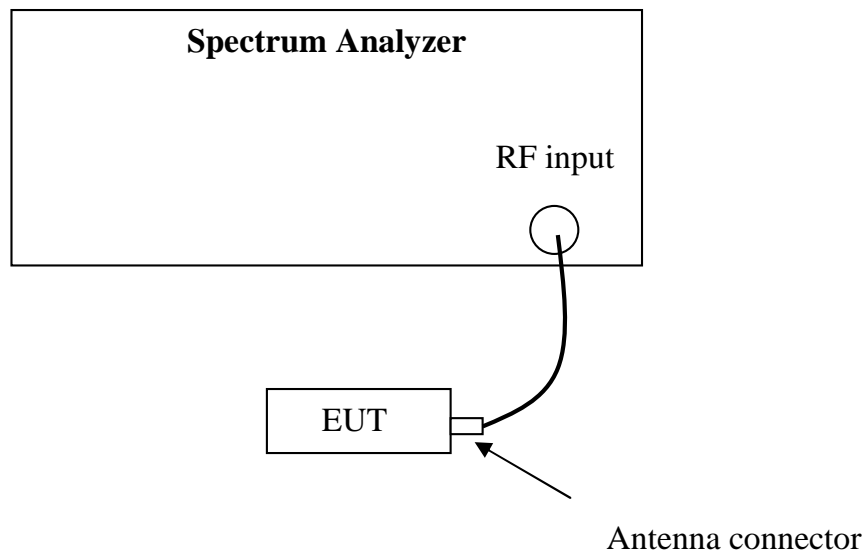

3.3 Test Procedure and test setup

The minimum 6dB bandwidth per FCC §15.247(a)(2) is measured using the Spectrum Analyzer with the resolutions bandwidth set at 100kHz, the video bandwidth set at 300kHz, and the SPAN>>RBW. The test was performed at 3 channels (lowest, middle and highest channel).

The EUT was tested according to DTS test procedure of Oct 2002 KDB558074 for compliance to FCC 47CFR 15.247 requirements.

3.4 Test Protocol

Temperature : 22°C
Relative Humidity : 43 %

Mode	CH	Antenna 1 (MHz)	Antenna 2 (MHz)	Limit (MHz)
-	L	1.28	-	≥ 0.5
	M	1.33	-	≥ 0.5
	H	1.46	-	≥ 0.5

4. Maximum peak output power

Test result: Pass

4.1 Test limit

For frequency hopping systems operating in the 2400-2483.5 MHz band employing at least 75 non-overlapping hopping channels, and all frequency hopping systems in the 5725-5850 MHz band: 1 watt

For all other frequency hopping systems in the 2400-2483.5 MHz band: 0.125 watts

If the transmitting antenna of directional gain greater than 6dBi is used, the power shall be reduced by the amount in dB that the directional gain of the antenna exceeds 6dBi.

For systems using digital modulation in the 902-928 MHz, 2400-2483.5 MHz, and 5725-5850 MHz bands: 1 Watt.

4.2 Test Configuration

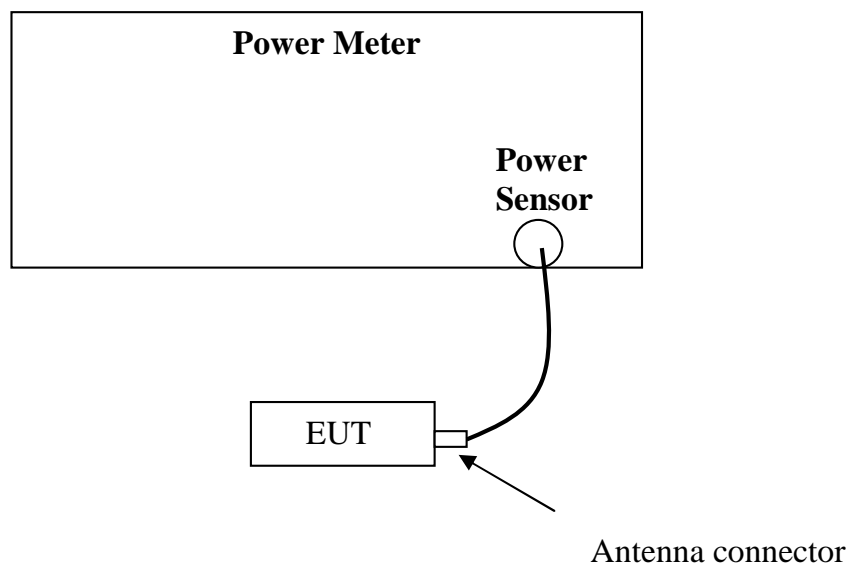

4.3 Test procedure and test setup

The power output per FCC § 15.247(b) is measured using the Spectrum Analyzer with the resolutions bandwidth set at 1MHz, the video bandwidth set at 3MHz, and the SPAN>>RBW. The test was performed at 3 channels (lowest, middle and highest channel). The EUT was tested according to DTS test procedure of Oct 2002 KDB558074 for compliance to FCC 47CFR 15.247 requirements (Power Output Option 1).

4.4 Test protocol

Temperature : 22 °C
Relative Humidity : 43 %

Mode	CH	Cable loss (dB)	Corrected reading (dBm)	Limit (dBm)
-	L	0	19.99	≤30
	M	0	20.21	≤30
	H	0	19.96	≤30

Note: Please refer to the test data for corrected reading.

For the gain of antenna = 3.50dBi, the maximum e.i.r.p = 20.21dBm + 3.50dBi = 23.71dBm = 0.23W (lower than the e.i.r.p limit of 4W showed in RSS-210.).

5. Power spectrum density

Test result: Pass

5.1 Test limit

For digitally modulated systems, the power spectral density conducted from the intentional radiator to the antenna shall not be greater than 8dBm in any 3 kHz band during any time interval of continuous transmission.

5.2 Test Configuration

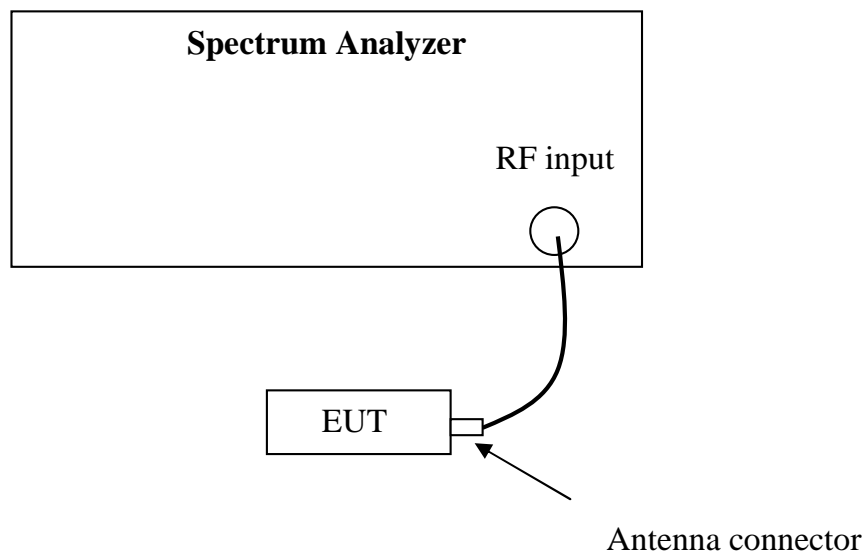

5.3 Test procedure and test setup

The power output per FCC §15.247(e) was measured using the Spectrum Analyzer with the resolutions bandwidth set at 3kHz, the video bandwidth set at 10kHz. The test was performed at 3 channels (lowest, middle and highest channel).

The EUT was tested according to DTS test procedure of Oct 2002 KDB558074 for compliance to FCC 47CFR 15.247 requirements.

5.4 Test Protocol

Temperature : 22 °C
Relative Humidity : 43 %

Mode	CH	Antenna 1 (dBm/3kHz)	Antenna 2 (dBm/3kHz)	Limit (dBm/3kHz)
-	L	4.15	-	≤8
	M	5.21	-	≤8
	H	4.45	-	≤8

6. Radiated emission

Test result: **PASS**

6.1 Test limit

The radiated emissions which fall in the restricted bands, as defined in §15.205(a), must also comply with the radiated emission limits specified in §15.209(a) showed as below:

Frequency (MHz)	Field Strength (dBuV/m)	Measurement Distance (m)
30 - 88	40.0	3
88 - 216	43.5	3
216 - 960	46.0	3
Above 960	54.0	3

6.2 Test Configuration

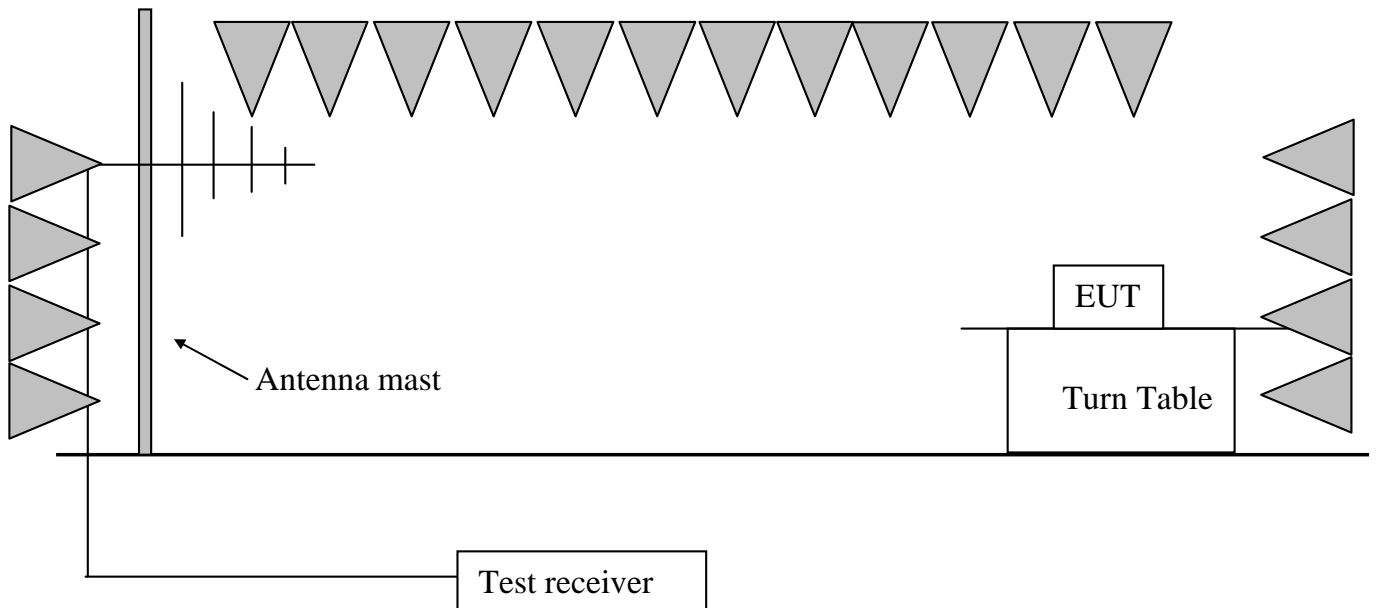

6.3 Test procedure and test setup

The measurement was applied in a semi-anechoic chamber. While testing for spurious emission higher than 1GHz, if applied, the pre-amplifier would be equipped just at the output terminal of the antenna.

The EUT and simulators were placed on a 0.8m high wooden turntable above the horizontal metal ground plane. The turn table rotated 360 degrees to determine the position of the maximum emission level. The EUT was set 3 meters away from the receiving antenna which was mounted on an antenna mast. The antenna moved up and down between from 1meter to 4 meters to find out the maximum emission level.

The EUT was tested according to DTS test procedure of Oct 2002 KDB558074 for compliance to FCC 47CFR 15.247 requirements.

The radiated emission was measured using the Spectrum Analyzer with the resolutions bandwidth set as:

RBW = 100kHz, VBW = 300kHz (30MHz~1GHz)

RBW = 1MHz, VBW = 3MHz (>1GHz for PK);

RBW = 1MHz, VBW = 10Hz (>1GHz for AV);

6.4 Test protocol

CH	Antenna (H/V)	Frequency (MHz)	Correct Factor (dB/m)	Corrected Reading (dBuV/m)	Limit (dBuV/m)	Margin (dB)	Detector
L	V	2405.80	30.70	121.20	Fundamental	/	PK
	H	125.25	10.50	30.20	43.50	13.30	PK
	V	4305.62	-4.50	58.70	74.00	15.30	PK
	V	4303.34	-4.50	23.10	54.00	30.90	AV
	V	4811.22	-2.70	72.40	74.00	1.60	PK
	V	4806.58	-2.70	34.20	54.00	19.80	AV
	V	7219.67	3.70	71.10	74.00	2.90	PK
	V	7217.03	3.70	32.30	54.00	21.70	AV
	V	2390.00	30.70	71.60	74.00	2.40	PK
	V	2390.00	30.70	36.40	54.00	17.60	AV
	V	2483.50	30.70	51.60	54.00	2.40	PK
M	V	2441.35	30.70	121.70	Fundamental	/	PK
	H	125.25	10.50	30.20	43.50	13.30	PK
	V	4310.18	-4.20	59.40	74.00	14.60	PK
	V	4309.57	-4.20	23.90	54.00	30.10	AV
	V	4883.12	-2.30	72.90	74.00	1.10	PK
	V	4881.69	-2.30	34.60	54.00	19.40	AV
	V	7325.11	3.90	71.70	74.00	2.30	PK
	V	7322.06	3.90	32.50	54.00	21.50	AV
	V	2390.00	30.70	52.10	54.00	1.90	PK
	V	2483.50	30.70	51.90	54.00	2.10	PK
H	V	2479.68	30.70	120.70	Fundamental	/	PK
	H	125.25	10.50	30.20	43.50	13.30	PK
	V	4315.58	-4.00	58.90	74.00	15.10	PK
	V	4313.66	-4.00	23.40	54.00	30.60	AV
	V	4962.27	-2.10	72.30	74.00	1.70	PK

V	4962.14	-2.10	34.30	54.00	19.70	AV
V	7441.90	4.30	70.80	74.00	3.20	PK
V	7439.05	4.30	32.10	54.00	21.90	AV
V	2390.00	30.70	51.40	54.00	2.60	PK
V	2483.50	30.70	72.80	74.00	1.20	PK
V	2483.50	30.70	36.90	54.00	17.10	AV

Remark: 1. For fundamental & restrict emission at 2300-2390MHz and 2483.5-2500MHz test, no amplifier is employed.

2. Correct Factor = Antenna Factor + Cable Loss (-Amplifier, is employed)

3. Corrected Reading = Original Receiver Reading + Correct Factor

4. Margin = limit – Corrected Reading

5. If the PK reading is lower than AV limit, the AV test can be elided.

Example: Assuming Antenna Factor = 30.20dB/m, Cable Loss = 2.00dB,

Gain of Preamplifier = 32.00dB, Original Receiver Reading = 10dBuV.

Then Correct Factor = 30.20 + 2.00 – 32.00 = 0.20dB/m; Corrected Reading =

10dBuV + 0.20dB/m = 10.20dBuV/m

Assuming limit = 54dBuV/m, Corrected Reading = 10.20dBuV/m, then Margin =

54 - 10.20 = 43.80dBuV/m

7. Emission outside the frequency Band

Test result: PASS

7.1 Limit

In any 100 kHz bandwidth outside the frequency band in which the spread spectrum intentional radiator is operating, the radio frequency power that is produced by the intentional radiator shall be at least 20 dB below that in the 100 kHz bandwidth within the band that contains the highest level of the desired power.

7.2 Test Configuration

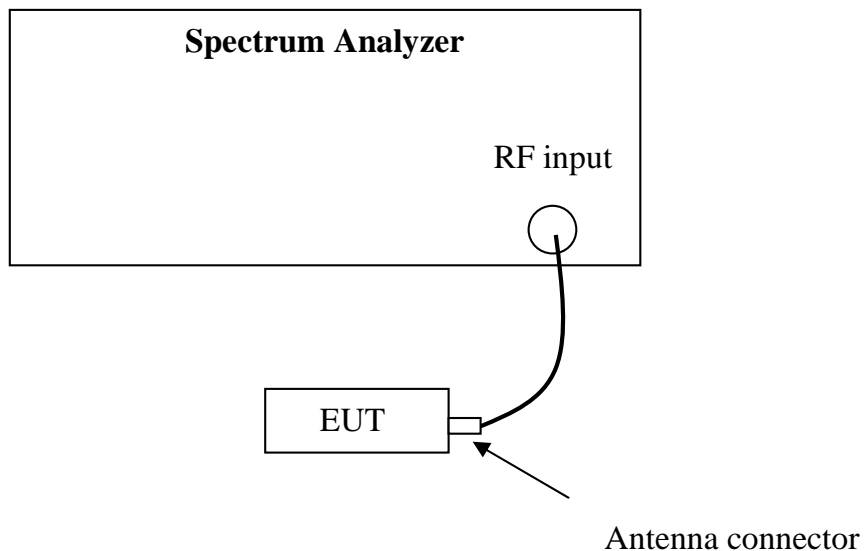

7.3 Test procedure and test setup

The Emission outside the frequency Band per FCC §15.247(d) is measured using the Spectrum Analyzer with the resolutions bandwidth set at 100kHz, the video bandwidth set at 300kHz, and the SPAN>>RBW.

The EUT was tested according to DTS test procedure of Oct 2002 KDB558074 for compliance to FCC 47CFR 15.247 requirements.

7.4 Test protocol

The worst RF antenna conducted emission test data is listed below:

Antenna	CH	Min Attenuation outside band (dB)	Limit (dB)
1	L	42.53	≥20
	M	49.95	
	H	35.68	

Note: Min Attenuation outside band = Max reading among band – Max reading outside band.
Please refer to the “test data” for band edge graph.

8. Power line conducted emission

Test result: Pass

8.1 Limit

Frequency of Emission (MHz)	Conducted Limit (dBuV)	
	QP	AV
0.15-0.5	66 to 56*	56 to 46 *
0.5-5	56	46
5-30	60	50

* Decreases with the logarithm of the frequency.

8.2 Test configuration

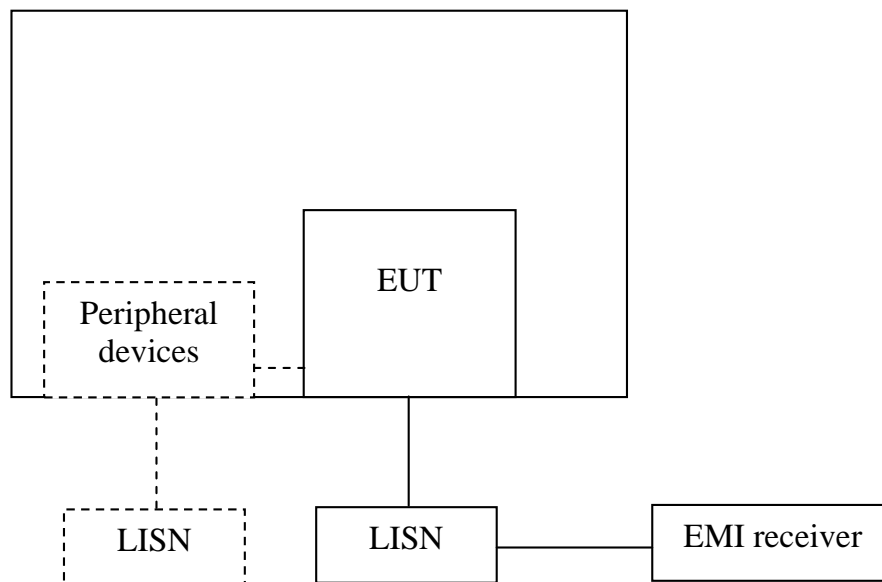

For table top equipment, wooden support is 0.8m height table

For floor standing equipment, wooden support is 0.1m height rack.

8.3 Test procedure and test set up

The EUT are connected to the main power through a line impedance stabilization network (LISN). This provides a 50Ω/50uH coupling impedance for the measuring equipment. The peripheral devices are also connected to the main power through a LISN that provides a 50Ω/50uH coupling impedance with 50Ω termination.

Both sides (Line and Neutral) of AC line are checked for maximum conducted interference. In order to find the maximum emission, the relative positions of equipment and all of the interface cables must be changed according to ANSI C63.4 on conducted measurement.

The bandwidth of the test receiver is set at 9 kHz.

The EUT was tested according to DTS test procedure of Oct 2002 KDB558074 for compliance to FCC 47CFR 15.247 requirements.

8.4 Test protocol

Frequency	Correct Factor (dB)	Corrected Reading (dBuV)		Limit (dBuV)		Margin (dB)	
		QP	AV	QP	AV	QP	AV
0.27 (L)	3.00	44.26	32.70	61.06	51.06	16.80	18.36
0.55 (L)	3.00	42.53	28.28	56.00	46.00	13.47	17.72
0.81 (N)	3.00	38.59	23.78	56.00	46.00	17.41	22.22
5.02 (N)	3.00	35.12	19.53	60.00	50.00	24.88	30.47
8.27 (N)	3.00	34.57	18.41	60.00	50.00	25.43	31.59
14.79 (L)	3.00	42.29	18.28	60.00	50.00	17.71	31.72
Remark: 1. Correction Factor (dB) = LISN Factor (dB) + Cable Loss (dB). 2. Margin (dB) = Limit - Corrected Reading.							

9. Channel Number of hopping system

Test result: NA

9.1 Limit

Frequency hopping systems in the 2400-2483.5 MHz band shall use at least 15 channels.

9.2 Test Configuration

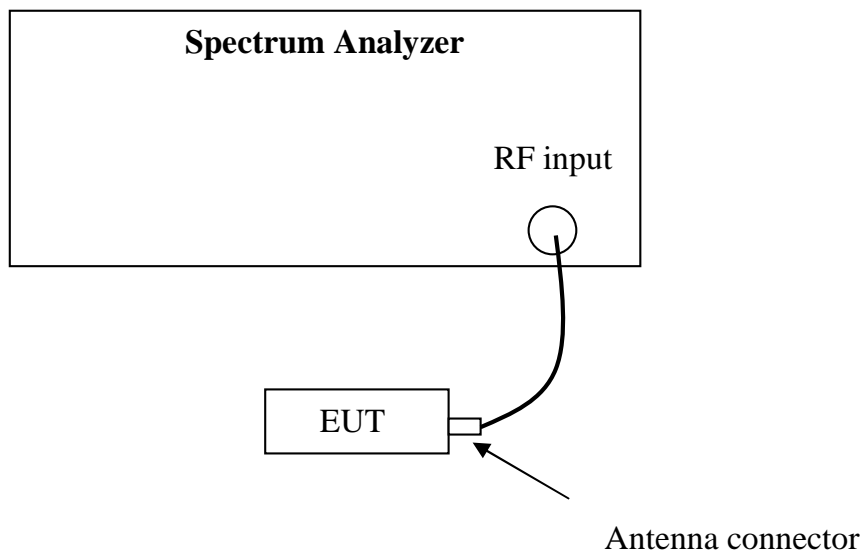

9.3 Test procedure and test setup

The channel number per FCC §15.247(a)(1)(iii) is measured using the Spectrum Analyzer with the resolutions bandwidth set at 100kHz, the video bandwidth set at 300kHz, and the SPAN>>RBW.

The RF passband of the EUT was divided into 3 appropriate bands to test.

9.4 Test protocol

Channel Number	Limit
-	≥ 15

10. Average time of occupancy in any channel

Test result: NA

10.1 Limit

The average time of occupancy on any channel shall not be greater than 0.4 seconds within a period of 0.4 seconds multiplied by the number of hopping channels employed. Frequency hopping systems may avoid or suppress transmissions on a particular hopping frequency provided that a minimum of 15 channels are used.

10.2 Test Configuration

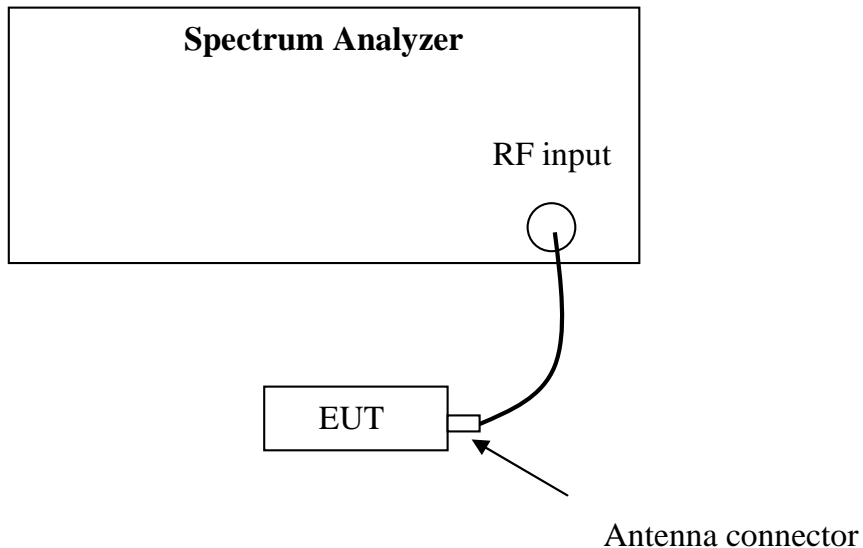

10.3 Test procedure and test setup

Average time of occupancy in any channel per FCC § 15.247(a)(1)(iii) is measured using the Spectrum Analyzer with the resolutions bandwidth set at 100kHz, the video bandwidth set at 300kHz, and the SPAN set to be 0Hz to test in time domain. The test is performed at the middle channel.

10.4 Test protocol

Packet	Observed period (s) P	Time of occupancy for single hopping (ms) O	Hops among the interval of 3.6 s I	Average time of occupancy (s) T	Limit (s)
Packet Type 4	-	-	-	-	≤0.4
Packet Type 11	-	-	-	-	≤0.4
Packet Type 15	-	-	-	-	≤0.4

Remark: 1. There are 79 channels in all. So the observed period $P = 0.4 * 79 = 31.6$ s.

2. Average time of occupancy $T = O * I * P / 3.6$

11. Occupied Bandwidth

Test Status: Tested

11.1 Test limit

None

11.2 Test Configuration

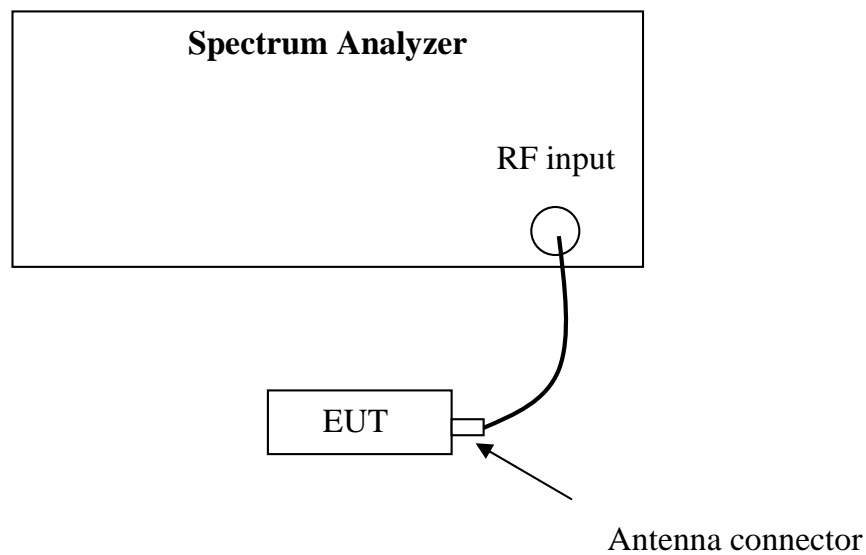

11.3 Test procedure and test setup

The occupied bandwidth per RSS-Gen Issue 3 Clause 4.6.1 was measured using the Spectrum Analyzer with the resolutions bandwidth set at 100kHz, the video bandwidth set at 300kHz.



11.4 Test protocol

Temperature : 22 °C
Relative Humidity : 43 %

Antenna	Occupied Bandwidth (MHz)
1	2.36

12. Spurious emission for receiver

Test result: PASS

12.1 Test limit

The spurious emission shall test through 3 times tuneable or local oscillator frequency whichever is the higher, without exceeding 40 GHz.

1) If a conducted measurement is made, no spurious output signals appearing at the antenna terminals shall exceed 2nW per any 4 kHz spurious frequency in the band 30-1000 MHz, or 5nW above 1 GHz.

2) If a radiated measurement is made, all spurious emissions shall comply with the limits of Table below:

Frequency (MHz)	Field Strength (dBuV/m)	Measurement Distance (m)
30 - 88	40.0	3
88 - 216	43.5	3
216 - 960	46.0	3
Above 960	54.0	3

12.2 Test Configuration

Please refer to clause 6.2

12.3 Test procedure and test setup

Please refer to clause 6.3.

12.4 Test protocol

Polarization	Frequency (MHz)	Correct Factor (dB/m)	Corrected Reading (dBuV/m)	Limit (dBuV/m)	Margin (dB)	Detector
V	59.16	5.50	28.10	40.00	11.90	PK
V	64.99	6.30	37.60	40.00	2.40	QP
H	70.82	7.60	30.80	40.00	9.20	PK
H	125.25	10.50	30.20	43.50	13.30	PK
H	280.76	12.50	33.40	46.00	12.60	PK
H	632.61	19.80	34.40	46.00	11.60	PK

- Remark: 1. Correct Factor = Antenna Factor + Cable Loss (-Amplifier, is employed)
 2. Corrected Reading = Original Receiver Reading + Correct Factor
 3. Margin = limit – Corrected Reading

Example: Assuming Antenna Factor = 30.20dB/m, Cable Loss = 2.00dB,
 Original Receiver Reading = 10dBuV.
 Then Correct Factor = 30.20 + 2.00 = 32.20dB/m; Corrected Reading = 10dBuV + 32.20dB/m = 42.20dBuV/m
 Assuming limit = 54dBuV/m, Corrected Reading = 42.20dBuV/m, then Margin = 54 -42.20 = 11.80dBuV/m