

FCC & IC TEST REPORT for Bluetooth LE
No. 180200047SHA-001

Applicant : RAE Systems Inc.
3775 N. 1st St., San Jose, California USA 95134

Manufacturing site : Same as applicant

Product Name : Honeywell BW CONNECT/BEACON

Type/Model : BWC-1001, BWC-1002

TEST RESULT : PASS

SUMMARY

The equipment complies with the requirements according to the following standard(s) or specification:

47CFR Part 15 (2017): Radio Frequency Devices

ANSI C63.10 (2013): American National Standard of Procedures for Compliance Testing of Unlicensed Wireless Devices

RSS-247 Issue 2 (Feb 2017): Digital Transmission Systems (DTSs), Frequency Hopping Systems (FHSs) and Licence-Exempt Local Area Network (LE-LAN) Devices

RSS-Gen Issue 4 (December 2014): General Requirements for Compliance of Radio Apparatus

KDB 558074 (V04): GUIDANCE FOR PERFORMING COMPLIANCE MEASUREMENTS ON DIGITAL TRANSMISSION SYSTEMS (DTS) OPERATING UNDER SECTION 15.247

Date of issue: March 9, 2018

Prepared by:

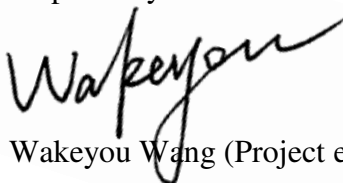
Wakeyou Wang (Project engineer)

Reviewed by:

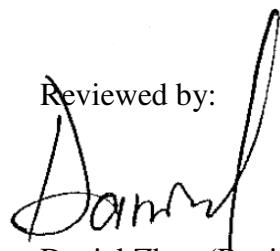
Daniel Zhao (Reviewer)

Description of Test Facility

Name: Intertek Testing Service Shanghai
Address: Building No.86, 1198 Qinzhou Road(North), Shanghai 200233, P.R.
China

FCC Accredited Lab Designation Number: CN1175
IC Assigned Code: 2042B-1

Name of contact: Jonny Jing
Tel: 86 21 61278271
Fax: 86 21 54262353

Content

SUMMARY.....	1
1 GENERAL INFORMATION	5
1.1 Description of Client.....	5
1.2 Identification of the EUT	5
1.3 Technical Specification.....	6
2 TEST SPECIFICATIONS.....	7
2.1 Standards or specification	7
2.2 Mode of operation during the test.....	7
2.3 Test software list	7
2.4 Test peripherals list	7
2.5 Instrument list	8
2.6 Test Summary	9
2.7 Measurement Uncertainty	10
3 MINIMUM 6dB BANDWIDTH	11
3.1 Limit.....	11
3.2 Test Configuration	11
3.3 Test Procedure and test setup.....	11
3.4 Test Protocol	12
4 MAXIMUM CONDUCTED OUTPUT POWER	14
4.1 Test limit	14
4.2 Test Configuration	14
4.3 Test procedure and test setup.....	15
4.4 Test protocol	16
5 POWER SPECTRUM DENSITY	17
5.1 Test limit	17
5.2 Test Configuration	17
5.3 Test procedure and test setup.....	18
5.4 Test Protocol	19
6 EMISSION OUTSIDE THE FREQUENCY BAND.....	21
6.1 Test limit	21
6.2 Test Configuration	21
6.3 Test procedure and test setup.....	21
6.4 Test Protocol	23
7 RADIATED EMISSIONS IN RESTRICTED FREQUENCY BANDS.....	27
7.1 Test limit	27
7.2 Test Configuration	28
7.3 Test procedure and test setup.....	29
7.4 Test Protocol	30
8 POWER LINE CONDUCTED EMISSION	31
8.1 Limit.....	31
8.2 Test configuration	31
8.3 Test procedure and test set up.....	32
8.4 Test protocol	33
9 OCCUPIED BANDWIDTH.....	34
9.1 Test limit	34
9.2 Test Configuration	34

Total Quality. Assured.

9.3 Test procedure and test setup35
9.4 Test protocol36

1 GENERAL INFORMATION

1.1 Description of Client

Applicant : RAE Systems Inc.
3775 N. 1st St., San Jose, California USA 95134

Manufacturing site : Same as applicant

1.2 Identification of the EUT

Product Name : Honeywell BW CONNECT/BEACON

Type/model : BWC-1001, BWC-1002

FCC ID : SU3BWC100

IC : 20969-BWC100

1.3 Technical Specification

Operation Frequency : 2402-2480MHz
Band

Type of Modulation : FHSS (Support BLE4.2 and 5.0)

EUT Modes of Modulation : GFSK

Channel Number : 40 (from 2402 to 2480 with spacing of 2MHz)

Description of EUT : There are two models. They are electrically identical except for different enclosure while BWC-1002 contains power key which allow the EUT to sleep or be waked up.

Port identification : /

Antenna : Chip Antenna, 1.0dBi

Rating : 3Vdc (CR2450N Battery)

Declared Temperature range : -40°C ~ 55°C

Category of EUT : Class B

EUT type : Table top
 Floor standing

Sample received date : Feb 7, 2018

Sample Identification : /
No

Date of test : Feb 7, 2018 – Feb 20, 2018

2 TEST SPECIFICATIONS

2.1 Standards or specification

47CFR Part 15 (2017)
ANSI C63.10 (2013)
RSS-247 Issue 2 (Feb 2017)
RSS-Gen Issue 4 (December 2014)
KDB 558074 (V04)

2.2 Mode of operation during the test

While testing transmitting mode of EUT, the internal modulation and continuously transmission was applied.

The EUT is a portable device, so three axes (X, Y, Z) were observed while the test receiver worked as “max hold” continuously and the highest reading among the whole test procedure was recorded.

Test software setting: default power setting among the software *SmartRF Studio* (released by TI).

The lowest, middle and highest channel were tested as representatives.

Freq. Band (MHz)	Modulation	L (MHz)	M (MHz)	H (MHz)
2400-2483.5	GFSK	2402	2440	2480

2.3 Test software list

Test Items	Software	Manufacturer	Version
Conducted emission	ESxS-K1	R&S	V2.1.0
Radiated emission	ES-K1	R&S	V1.71

2.4 Test peripherals list

Item No.	Name	Band and Model	Description
1	Laptop computer	DELL, Latitude E5470	-

2.5 Instrument list

Radiated Emission					
Used	Equipment	Manufacturer	Type	Internal no.	Due date
<input checked="" type="checkbox"/>	Test Receiver	R&S	ESIB 26	EC 3045	2018-10-18
<input checked="" type="checkbox"/>	Bilog Antenna	TESEQ	CBL 6112D	EC 4206	2018-05-30
<input checked="" type="checkbox"/>	Horn antenna	R&S	HF 906	EC 3049	2018-09-22
<input type="checkbox"/>	Horn antenna	ETS	3117	EC 4792-1	2018-08-23
<input checked="" type="checkbox"/>	Pre-amplifier	R&S	Pre-amp 18	EC5881	2018-06-19
<input checked="" type="checkbox"/>	Semi-anechoic chamber	Albatross project	-	EC 3048	2018-09-08
RF test					
Used	Equipment	Manufacturer	Type	Internal no.	Due date
<input checked="" type="checkbox"/>	PXA Signal Analyzer	Keysight	N9030A	EC 5338	2018-09-10
<input checked="" type="checkbox"/>	Power sensor / Power meter	Agilent	N1911A/N1921A	EC4318	2018-05-12
<input type="checkbox"/>	Vector Signal Generator	Agilent	N5182B	EC 5175	2018-03-06
<input type="checkbox"/>	MXG Analog Signal Generator	Agilent	N5181A	EC 5338-2	2018-03-03
<input type="checkbox"/>	Mobile Test System	Litepoint	Iqxel	EC 5176	2018-01-11
<input checked="" type="checkbox"/>	Test Receiver	R&S	ESCI 7	EC 4501	2018-02-23
Additional instrument					
Used	Equipment	Manufacturer	Type	Internal no.	Due date
<input checked="" type="checkbox"/>	Therom-Hygrograph	ZJ1-2A	S.M.I.F.	EC 3323	2018-06-14
<input checked="" type="checkbox"/>	Therom-Hygrograph	ZJ1-2A	S.M.I.F.	EC 3324	2018-04-09
<input checked="" type="checkbox"/>	Therom-Hygrograph	ZJ1-2A	S.M.I.F.	EC 3325	2018-03-23
<input checked="" type="checkbox"/>	Pressure meter	YM3	Shanghai Mengde	EC 3320	2018-06-28
Conducted Emission					
Used	Equipment	Manufacturer	Type	Internal no.	Due date
<input type="checkbox"/>	Test Receiver	R&S	ESCS 30	EC 2107	2018-10-19
<input type="checkbox"/>	A.M.N.	R&S	ESH2-Z5	EC 3119	2018-12-01
<input type="checkbox"/>	I.S.N.	FCC	FCC-TLISN-T8-02	EC 3756	2019-02-07

2.6 Test Summary

This report applies to tested sample only. The test results have been compared directly with the limits, and the measurement uncertainty is recorded. This report shall not be reproduced in part without written approval of Intertek Testing Service Shanghai Limited.

TEST ITEM	FCC REFERANCE	IC REFERANCE	RESULT
Minimum 6dB Bandwidth & Occupied bandwidth	15.247(a)(2)	RSS-Gen (6.6) RSS-247 Issue 2 5.2 (a)	Pass
Maximum peak output power	15.247(b)	RSS-Gen (6.12) RSS-247 Issue 2 5.4 (d)	Pass
Power spectrum density	15.247(e)	RSS-247 Issue 2 5.2 (b)	Pass
Radiated emission	15.205 & 15.209	RSS-247 Issue 2 5.5	Pass
Emission outside the frequency band	15.247(d)	RSS-247 Issue 2 5.5	Pass
Power line conducted emission	15.207	RSS-Gen (8.8)	NA

Notes: 1: NA =Not Applicable

2.7 Measurement Uncertainty

Where relevant, the following measurement uncertainty levels have been estimated for tests performed on the EUT

Item No.	Test Items	Expanded Uncertainty (k=2) (±)
1	Radio frequency	0.84 × 10⁻⁷
2	RF power, conducted	0.74 dB
3	RF power, radiated	5.92 dB
5	Power Spectral Density, conducted	2.99 dB
6	Occupied Channel Bandwidth	0.88 %
7	Conducted emission at mains ports	3.19 dB
8	Radiated Emissions up to 1 GHz	4.90 dB
9	Radiated Emissions 1-6GHz	5.02 dB
19	Radiated Emissions 6-18GHz	5.28 dB

3 Minimum 6dB Bandwidth

Test result: Pass

3.1 Limit

For systems using digital modulation techniques that may operate in the 902 - 928 MHz, 2400 - 2483.5 MHz and 5725 - 5850 MHz bands, the minimum 6 dB bandwidth shall be at least 500 kHz.

3.2 Test Configuration

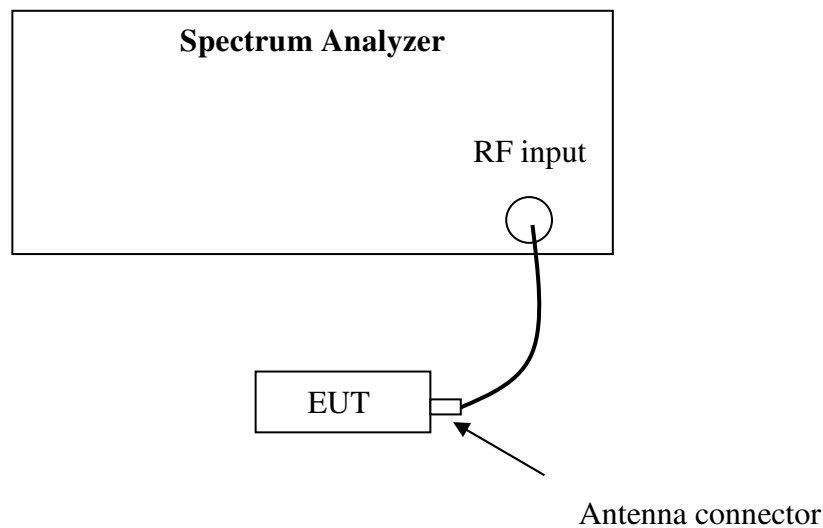

3.3 Test Procedure and test setup

The minimum 6dB bandwidth per FCC §15.247(a)(2) is measured using the Spectrum Analyzer according to DTS test procedure of "KDB558074 D01 DTS Meas Guidance" for compliance to FCC 47CFR 15.247 requirements (clause 8.2).

3.4 Test Protocol

Temperature: 23 °C

Relative Humidity: 43 %

BLE Occupied 6dB Bandwidth			
Test Frequency (MHz)	Occupied Bandwidth (kHz)	Min Limit (kHz)	Result
2402	706.8	500	Pass
2440	707.4	500	Pass
2480	753.1	500	Pass

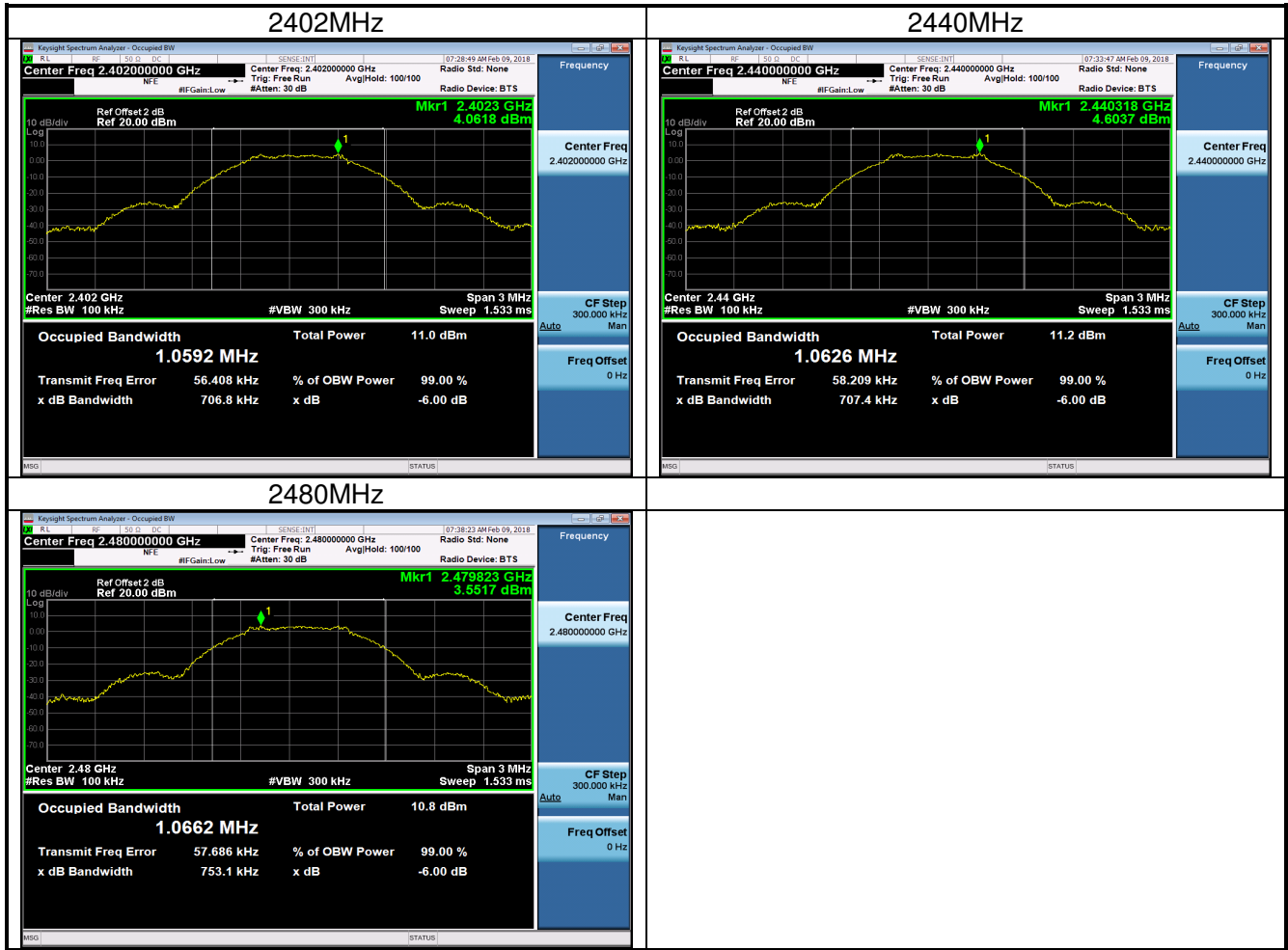

4 Maximum Conducted Output power

Test result: Pass

4.1 Test limit

For frequency hopping systems operating in the 2400-2483.5 MHz band employing at least 75 non-overlapping hopping channels, and all frequency hopping systems in the 5725-5850 MHz band: 1 watt

For all other frequency hopping systems in the 2400-2483.5 MHz band: 0.125 watts

For systems using digital modulation in the 902-928 MHz, 2400-2483.5 MHz, and 5725-5850 MHz bands: 1 Watt.

If the transmitting antenna of directional gain greater than 6dBi is used, the power shall be reduced by the amount in dB that the directional gain of the antenna exceeds 6dBi. If there have a beam forming type, the limit should be the minimum of 30dBm and 30+ (6 –antenna gain-beam forming gain).

4.2 Test Configuration

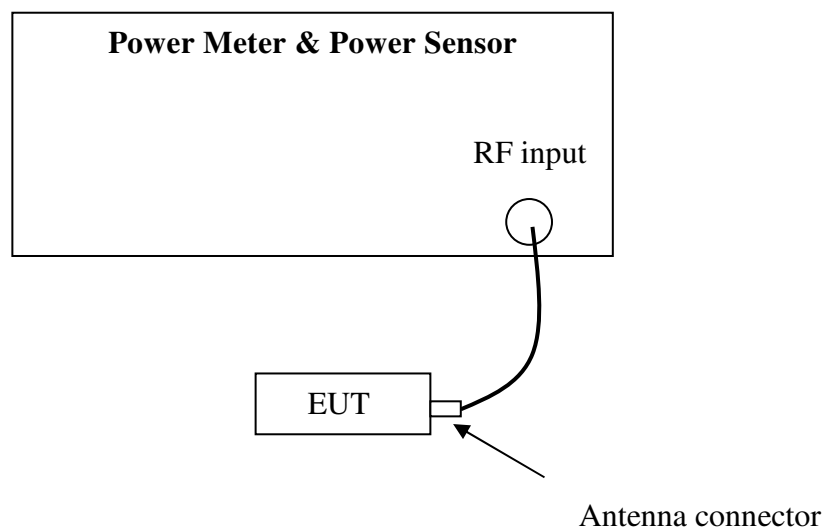

4.3 Test procedure and test setup

The EUT was tested according to DTS test procedure of “KDB558074 D01 DTS Meas Guidance” for compliance to FCC 47CFR 15.247 requirements (clause 9.1.3 PKPM1 Peak-reading power meter method).

The maximum peak conducted output power is measured using a broadband peak RF power meter. The power meter has a video bandwidth that is greater than the DTS bandwidth and utilizes a fast-responding diode detector.

4.4 Test protocol

Temperature: 22 °C
Relative Humidity: 43 %

BLE Maximum Output Power		
Test Frequency (MHz)	Power (dBm)	Result
2402	4.90	Pass
2440	4.96	Pass
2480	4.65	Pass

Note: Both Bluetooth 5.0 and 4.2 mode was assessed and it was found the test data is identical.

The Maximum EIRP = 4.96dBm + 1dBi = 5.96dBm = 3.945mW < IC EIRP limit of 4W

5 Power spectrum density

Test result: Pass

5.1 Test limit

For digitally modulated systems, the power spectral density conducted from the intentional radiator to the antenna shall not be greater than 8dBm in any 3 kHz band during any time interval of continuous transmission.

If the transmitting antenna of directional gain greater than 6dBi is used, the power shall be reduced by the amount in dB that the directional gain of the antenna exceeds 6dBi. If there have a beam forming type, the limit should be the minimum of 8dBm/MHz and $8 + (6 - \text{antenna gain} - \text{beam forming gain})$.

5.2 Test Configuration

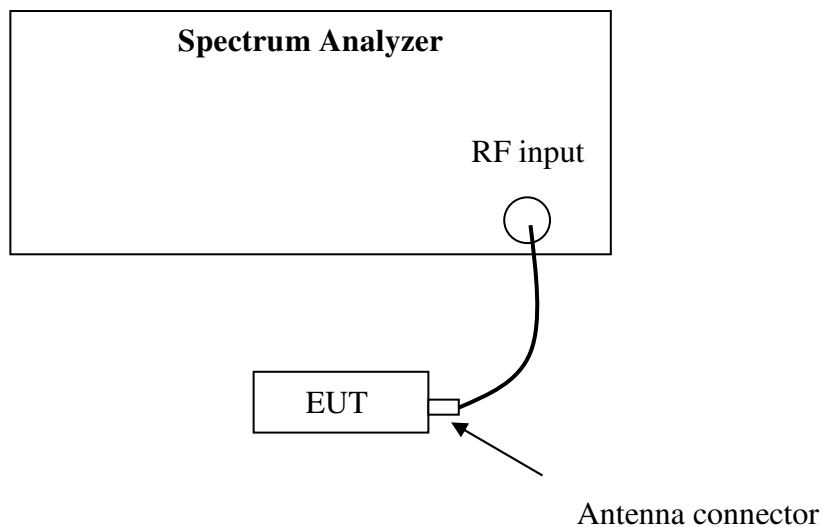

5.3 Test procedure and test setup

The power output per FCC §15.247(e) was tested according to DTS test procedure of “KDB558074 D01 DTS Meas Guidance” (clause 10.2) for compliance to FCC 47CFR 15.247 requirements.

This procedure shall be used if maximum peak conducted output power was used to demonstrate compliance, and is optional if the maximum conducted (average) output power was used to demonstrate compliance.

- a) Set analyzer center frequency to DTS channel center frequency.
- b) Set the span to $1.5 \times \text{DTS bandwidth}$.
- c) Set the RBW to: $3 \text{ kHz} \leq \text{RBW} \leq 100 \text{ kHz}$.
- d) Set the VBW $\geq 3\text{RBW}$.
- e) Detector = peak.
- f) Sweep time = auto couple.
- g) Trace mode = max hold.
- h) Allow trace to fully stabilize.
- i) Use the peak marker function to determine the maximum amplitude level within the RBW.
- j) If measured value exceeds limit, reduce RBW (no less than 3 kHz) and repeat.

5.4 Test Protocol

Temperature: 22 °C

Relative Humidity: 43 %

BLE Peak Power Spectral Density		
Test Frequency (MHz)	PSD (dBm/3kHz)	Result
2402	-3.90	Pass
2440	-5.50	Pass
2480	-4.09	Pass

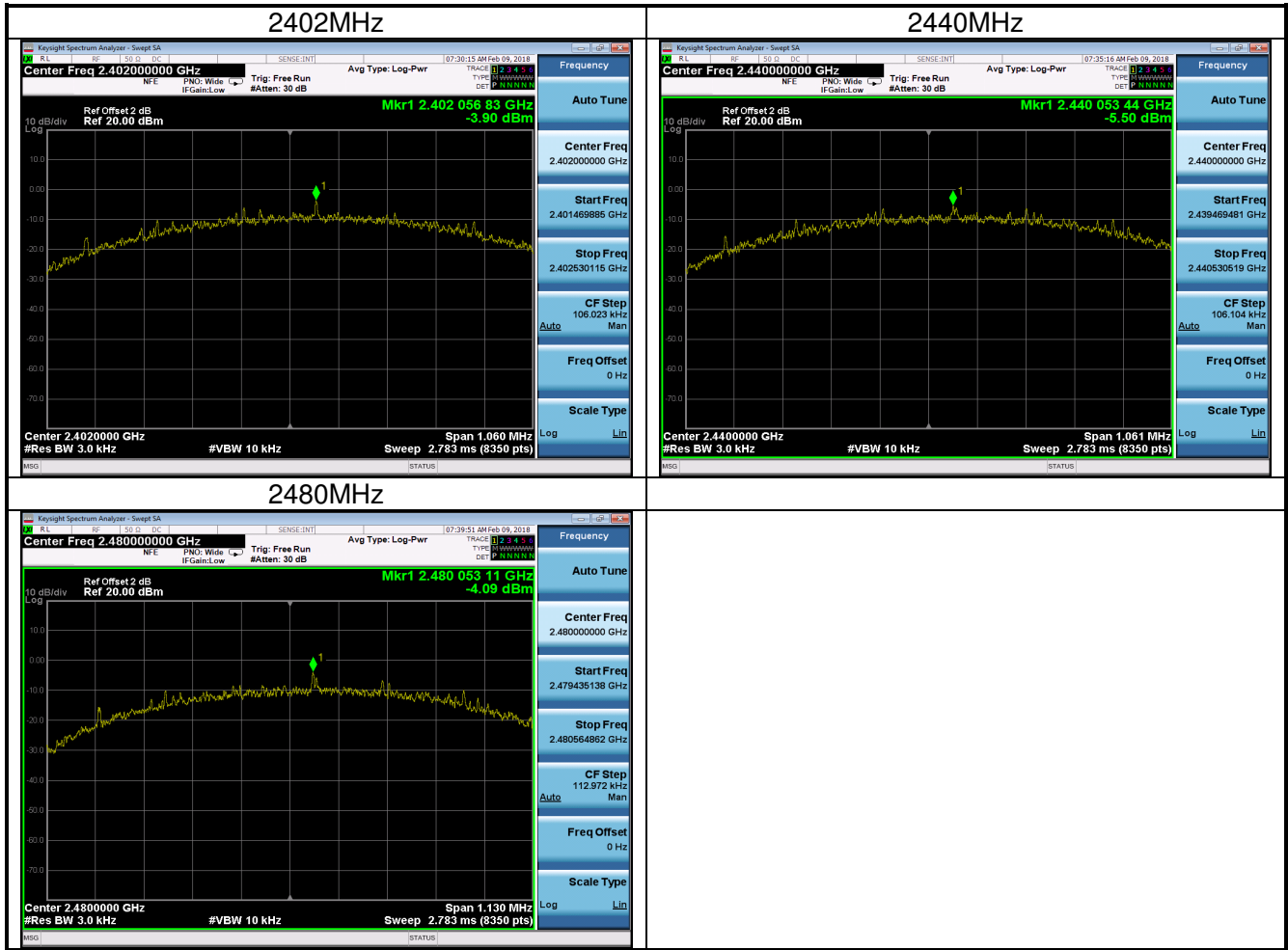

6 Emission outside the frequency band

Test result: Pass

6.1 Test limit

In any 100 kHz bandwidth outside the frequency band in which the spread spectrum intentional radiator is operating, the radio frequency power that is produced by the intentional radiator shall be at least 30 dB below that in the 100 kHz bandwidth within the band that contains the highest level of the desired power.

6.2 Test Configuration

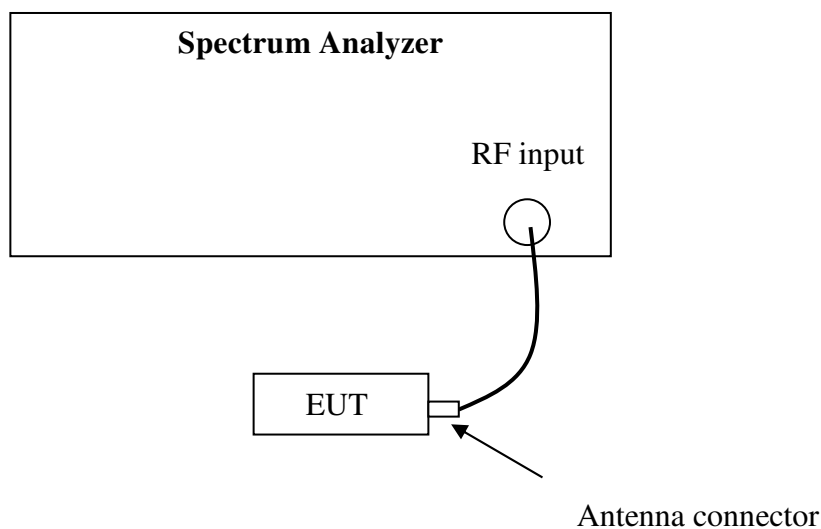

6.3 Test procedure and test setup

The Emission outside the frequency Band per FCC § 15.247(d) is measured using the Spectrum Analyzer with the resolutions bandwidth set at 100kHz, the video bandwidth set at 300kHz, and the SPAN>>RBW.

The EUT was tested according to DTS test procedure of “KDB558074 D01 DTS Meas Guidance” (clause 11.0) for compliance to FCC 47CFR 15.247 requirements.

If maximum conducted (average) output power was used to demonstrate compliance, then the peak power in any 100 kHz bandwidth outside of the authorized frequency band shall be attenuated by at least 30 dB relative to the maximum in-band peak PSD level in 100 kHz (*i.e.*, 30 dBc).

Reference level measurement

Establish a reference level by using the following procedure:

- a) Set instrument center frequency to DTS channel center frequency.
- b) Set the span to ≥ 1.5 times the *DTS bandwidth*.
- c) Set the RBW = 100 kHz.
- d) Set the VBW $\geq 3 \times$ RBW.
- e) Detector = peak.
- f) Sweep time = auto couple.
- g) Trace mode = max hold.
- h) Allow trace to fully stabilize.
- i) Use the peak marker function to determine the maximum PSD level.

Note that the channel found to contain the maximum PSD level can be used to establish the reference level.

Emission level measurement

- a) Set the center frequency and span to encompass frequency range to be measured.
- b) Set the RBW = 100 kHz.
- c) Set the VBW $\geq 3 \times$ RBW.
- d) Detector = peak.
- e) Ensure that the number of measurement points \geq span/RBW
- f) Sweep time = auto couple.
- g) Trace mode = max hold.
- h) Allow trace to fully stabilize.
- i) Use the peak marker function to determine the maximum amplitude level.

Ensure that the amplitude of all unwanted emissions outside of the authorized frequency band (excluding restricted frequency bands) are attenuated by at least the minimum requirements specified in 11.1 a) or 11.1 b). Report the three highest emissions relative to the limit.

6.4 Test Protocol

Temperature: 22 °C

Relative Humidity: 43 %

BLE Transmitter Spurious Emission			
Test Frequency (MHz)	Test Range	Power (dBm)	Result
2402	1MHz~2310MHz	-55.23	Pass
2402	2500MHz~5000MHz	-49.92	Pass
2402	5000MHz~25000MHz	-40.27	Pass
2402	Band Edge	-47.54	Pass
2402	Reference Level	4.50	Pass
2440	1MHz~2310MHz	-54.54	Pass
2440	2500MHz~5000MHz	-50.51	Pass
2440	5000MHz~25000MHz	-41.03	Pass
2440	Band Edge	-55.59	Pass
2440	Reference Level	4.51	Pass
2480	1MHz~2310MHz	-53.85	Pass
2480	2500MHz~5000MHz	-46.16	Pass
2480	5000MHz~25000MHz	-40.76	Pass
2480	Band Edge	-55.29	Pass
2480	Reference Level	4.44	Pass

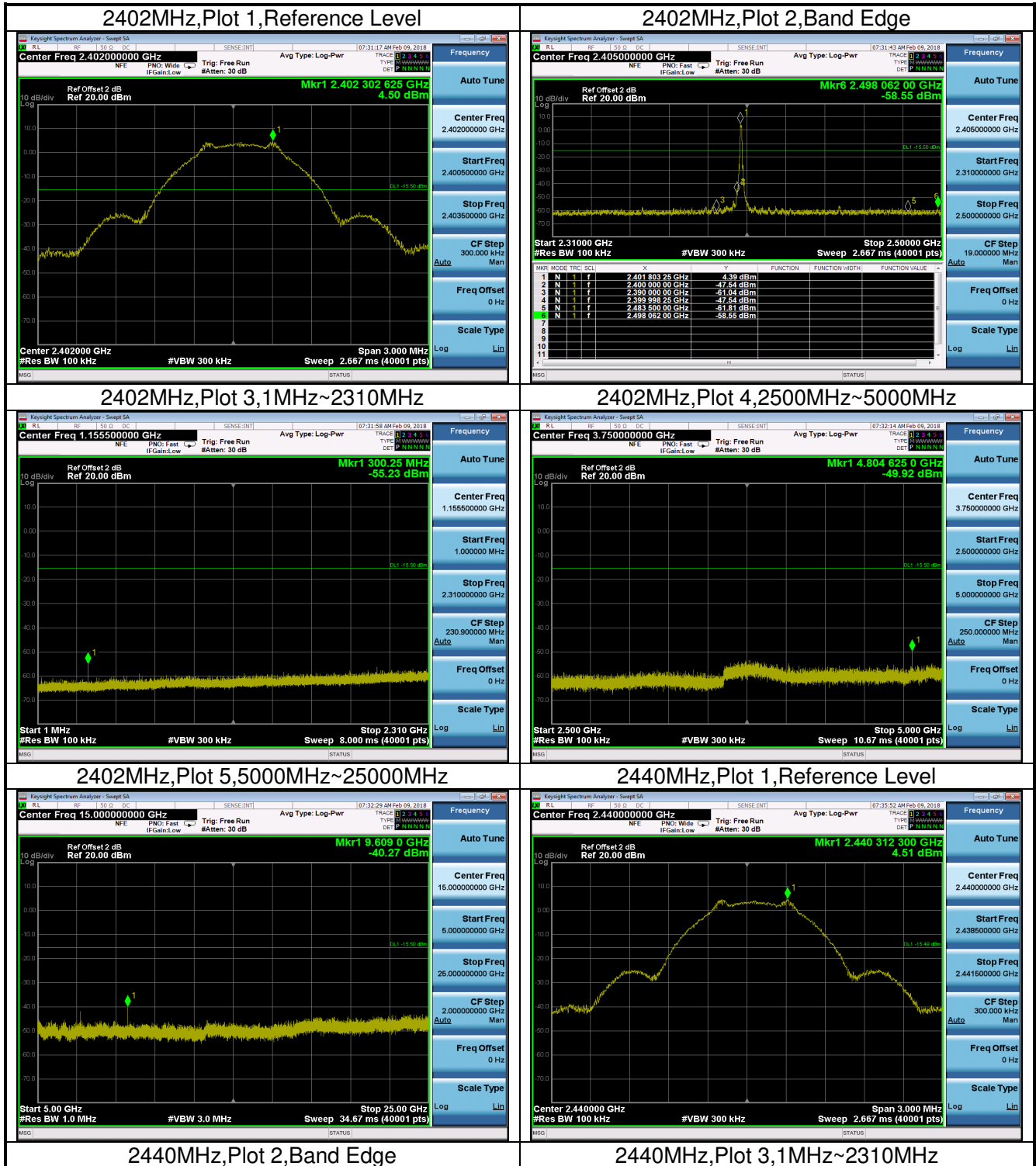

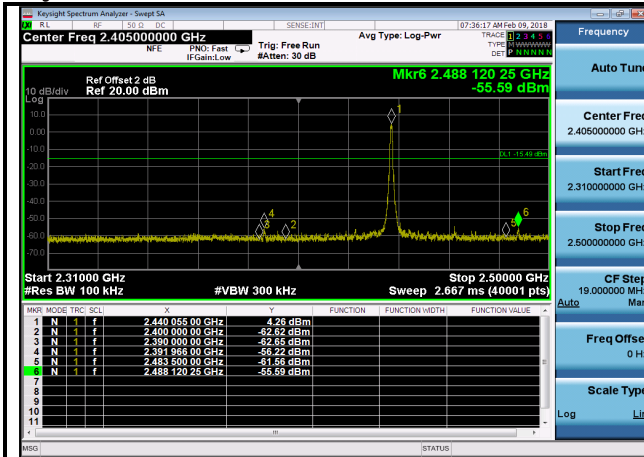

2440MHz,Plot 4,2500MHz~5000MHz

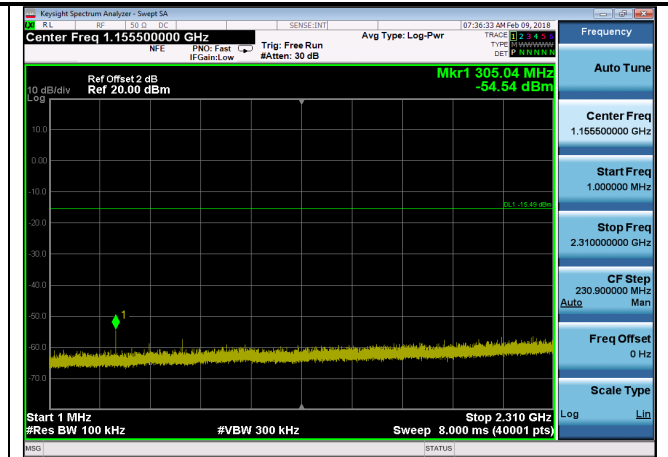

2440MHz,Plot 5,5000MHz~25000MHz

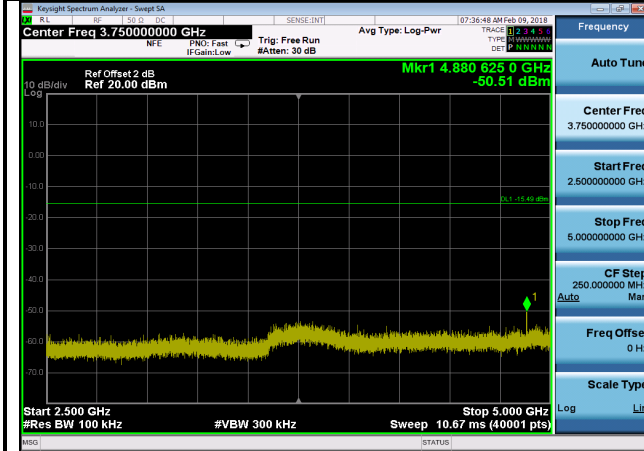

2420MHz,Plot 1,Reference Level

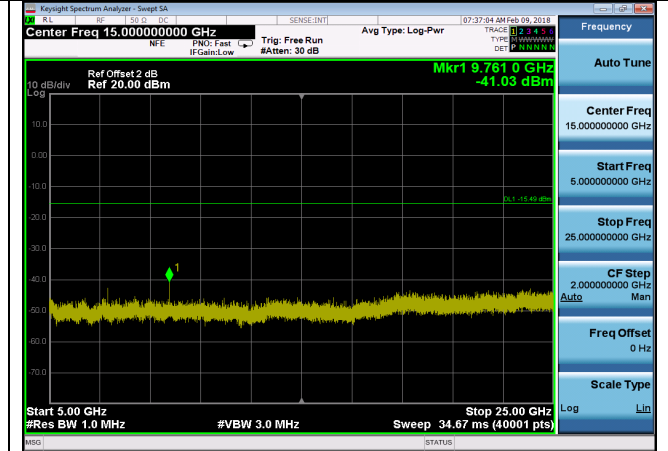

2480MHz,Plot 2,Band Edge

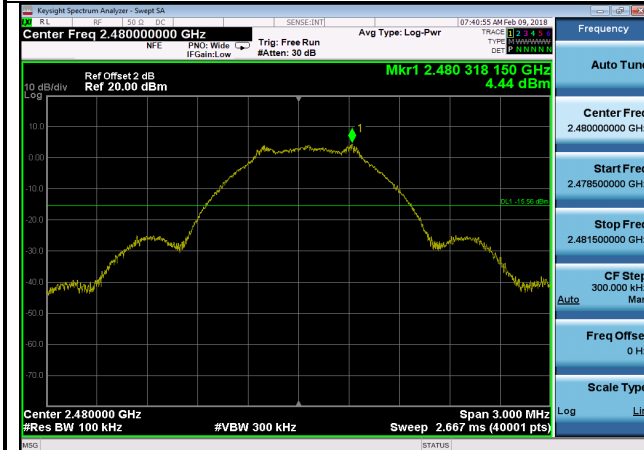

2480MHz,Plot 3,1MHz~2310MHz

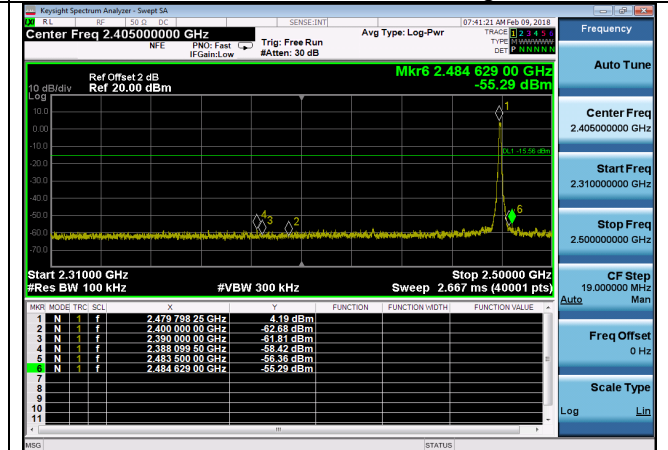

2480MHz,Plot 4,2500MHz~5000MHz

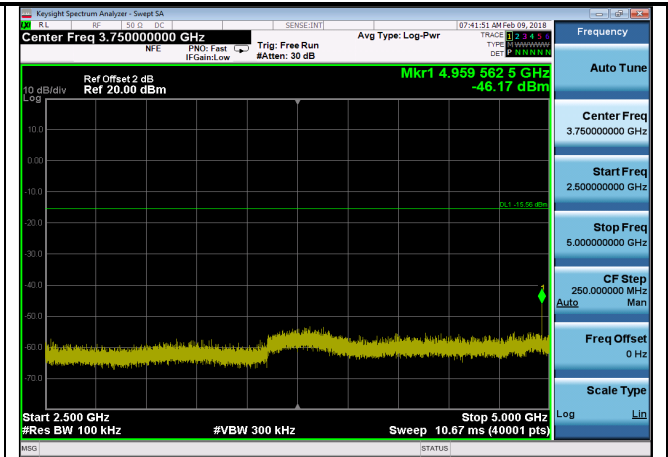
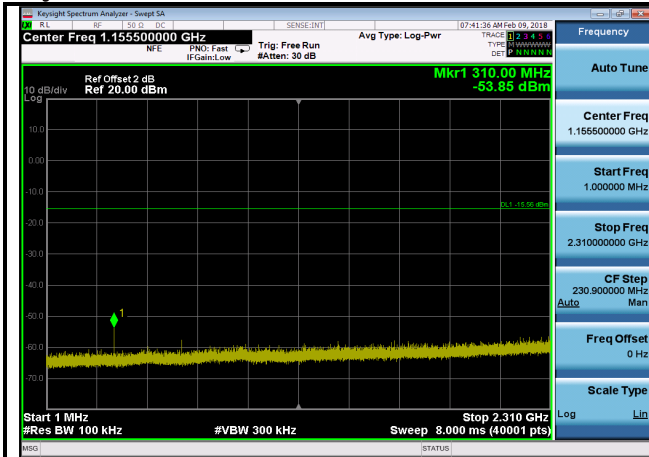

2480MHz, Plot 5, 5000MHz~25000MHz

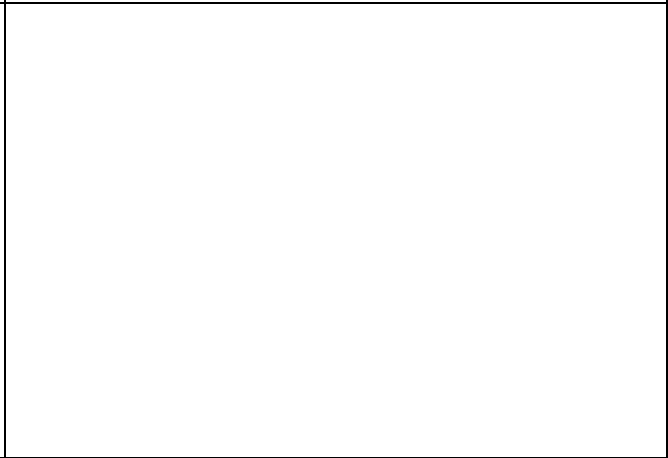
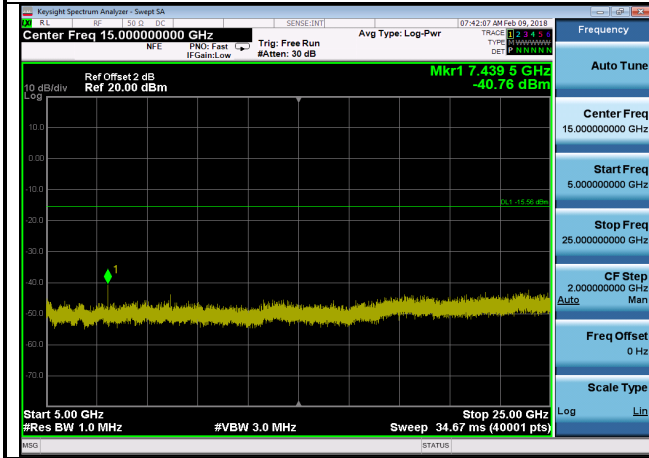

7 Radiated Emissions in restricted frequency bands

Test result: Pass

7.1 Test limit

The radiated emissions which fall in the restricted bands, as defined in § 15.205(a), must also comply with the radiated emission limits specified in § 15.209(a) showed as below:

Frequencies (MHz)	Field Strength (microvolts/meter)	Measurement Distance (meters)
0.009 ~ 0.490	2400/F(kHz)	300
0.490 ~ 1.705	24000/F(kHz)	30
1.705 ~ 30.0	30	30
30 ~ 88	100	3
88 ~ 216	150	3
216 ~ 960	200	3
Above 960	500	3

7.2 Test Configuration

Test configuration for $\leq 1\text{GHz}$

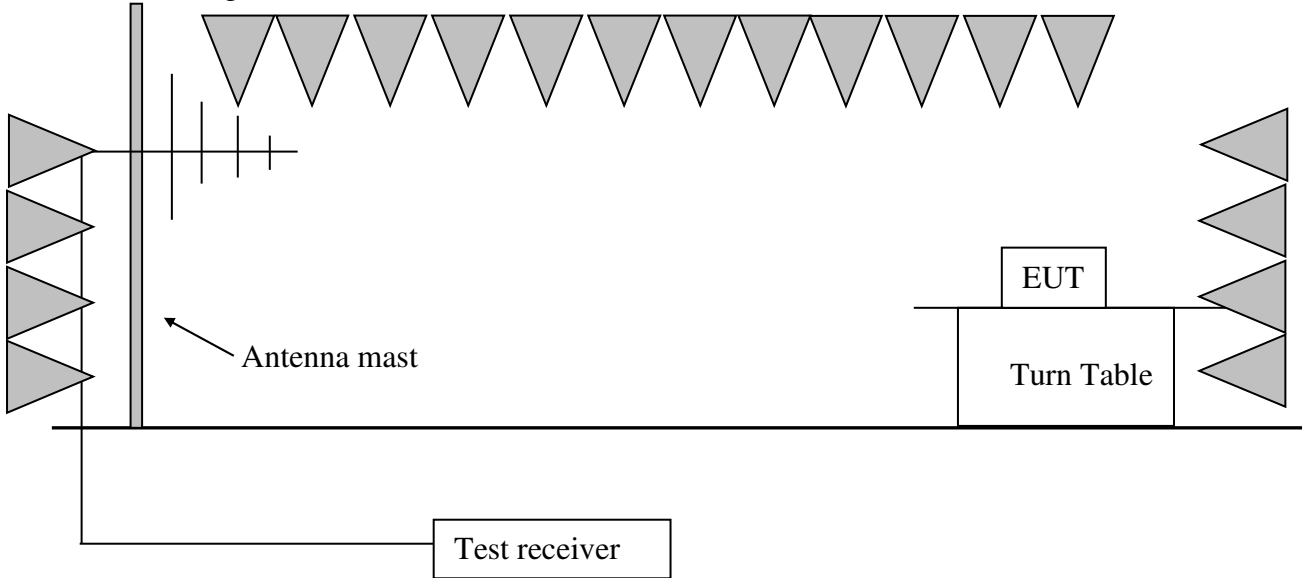

Test configuration for $>1\text{GHz}$

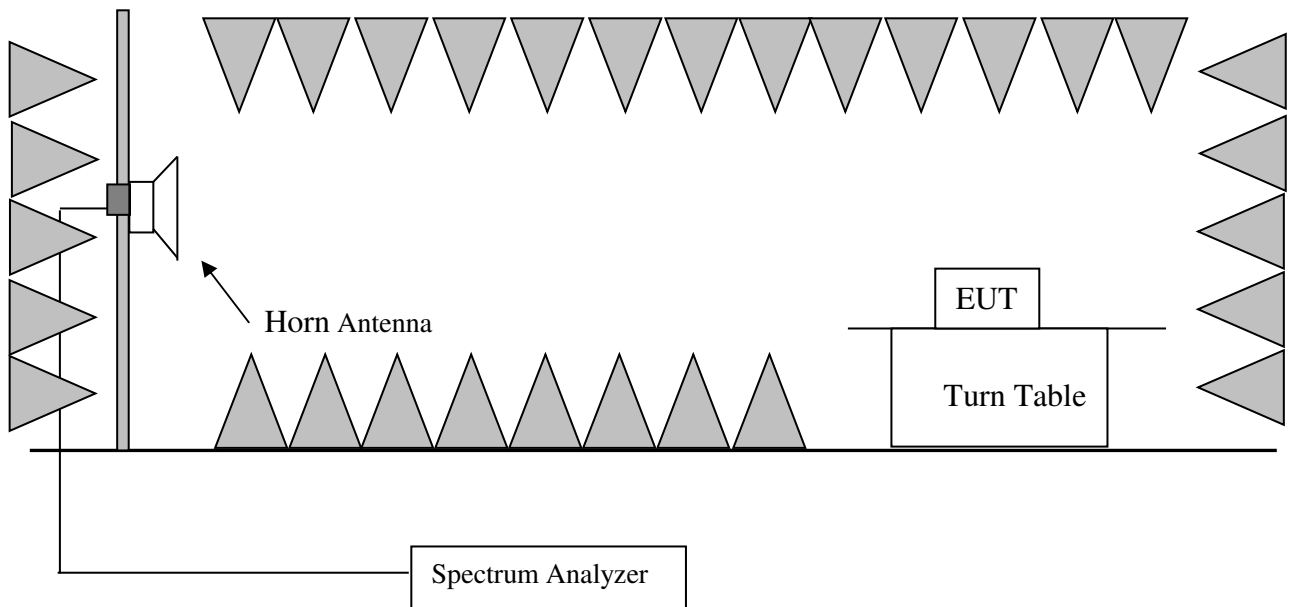

7.3 Test procedure and test setup

The measurement was applied in a semi-anechoic chamber. While testing for spurious emission higher than 1GHz, if applied, the pre-amplifier would be equipped just at the output terminal of the antenna.

Tabletop devices shall be placed on a nonconducting platform with nominal top surface dimensions 1 m by 1.5 m. For emissions testing at or below 1 GHz, the table height shall be 80 cm above the reference ground plane. For emission measurements above 1 GHz, the table height shall be 1.5 m.

The turntable rotated 360 degrees to determine the position of the maximum emission level. The EUT was set 3 meters away from the receiving antenna which was mounted on an antenna mast. The antenna moved up and down between from 1 meter to 4 meters to find out the maximum emission level.

The EUT was tested according to DTS test procedure of KDB558074 D01 DTS “Meas Guidance” for compliance to FCC 47CFR 15.247 requirements.

The radiated emission was measured using the Spectrum Analyzer with the resolutions bandwidth set as:

RBW = 300 Hz, VBW = 1 kHz (9 kHz~150 kHz);
RBW = 10 kHz, VBW = 30 kHz (150 kHz~30MHz);
RBW = 100 kHz, VBW = 300 kHz (30MHz~1GHz for PK)
RBW = 1MHz, VBW = 3MHz (>1GHz for PK);
RBW = 1MHz, VBW = 10Hz (>1GHz for AV);

Remark:

1. Factor= Antenna Factor + Cable Loss (-Amplifier, is employed)
2. Measured level= Original Receiver Reading + Factor
3. Margin = Limit – Measured level
4. If the PK measured level is lower than AV limit, the AV test can be elided.

Example:

Assuming Antenna Factor = 30.20dB/m, Cable Loss = 2.00dB,
Gain of Preamplifier = 32.00dB, Original Receiver Reading = 10dBuV.
Then Factor = 30.20 + 2.00 – 32.00 = 0.20dB/m;
Measured level = 10dBuV + 0.20dB/m = 10.20dBuV/m
Assuming limit = 54dBuV/m,
Measured level = 10.20dBuV/m, then Margin = 54 - 10.20 = 43.80dBuV/m.

7.4 Test Protocol

Temperature: 25 °C

Relative Humidity: 55 %

Channel	Frequency (MHz)	Measured level (dBμV/m)	Factor (dB)	Limits (dBμV/m)	Margin (dB)	Detector	Polarization
L	2402.36	96.10	30.30	Fundamental	/	PK	H
	57.21	39.10	7.40	40.00	0.90	PK	V
	156.35	36.00	11.30	43.50	7.50	PK	H
	2388.03	48.60	30.30	74.00	25.40	PK	H
	4795.59	47.50	0.40	74.00	26.50	PK	V
	9607.21	52.50	13.40	74.00	21.50	PK	H
M	2440.51	96.30	30.40	Fundamental	/	PK	H
	57.21	39.10	7.40	40.00	0.90	PK	V
	156.35	36.00	11.30	43.50	7.50	PK	H
	4879.75	45.20	0.50	74.00	28.80	PK	V
	7320.64	47.70	7.00	74.00	26.30	PK	H
	9761.52	47.50	13.50	74.00	26.50	PK	H
H	2480.36	94.10	30.50	Fundamental	/	PK	H
	57.21	39.10	7.40	40.00	0.90	PK	V
	156.35	36.00	11.30	43.50	7.50	PK	H
	2483.50	55.20	30.50	74.00	18.80	PK	H
	2483.50	49.90	30.50	54.00	4.10	AV	H
	4949.89	45.40	0.60	74.00	28.60	PK	V
	8919.83	47.60	13.00	74.00	26.40	PK	H

8 Power line conducted emission

Test result: NA

8.1 Limit

Frequency of Emission (MHz)	Conducted Limit (dBuV)	
	QP	AV
0.15-0.5	66 to 56*	56 to 46 *
0.5-5	56	46
5-30	60	50

* Decreases with the logarithm of the frequency.

8.2 Test configuration

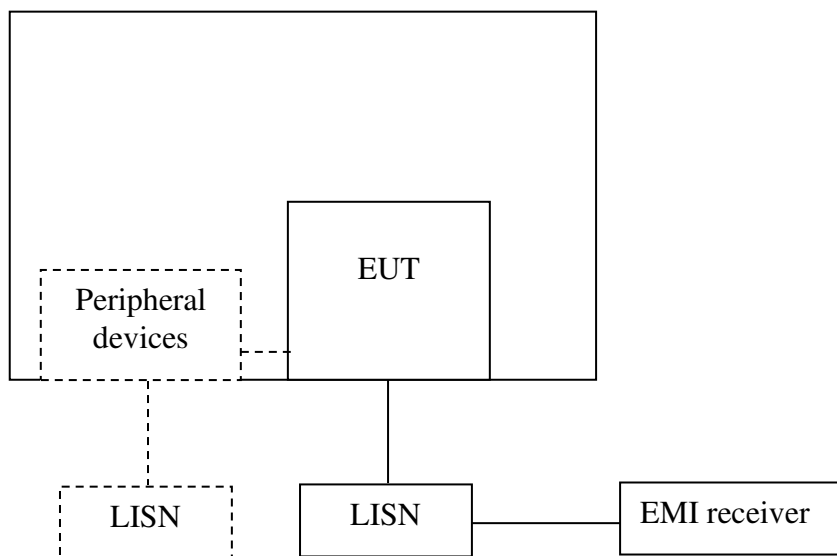

- For table top equipment, wooden support is 0.8m height table
- For floor standing equipment, wooden support is 0.1m height rack.

8.3 Test procedure and test set up

Measured levels of ac power-line conducted emission shall be the emission voltages from the voltage probe, where permitted, or across the 50 Ω LISN port (to which the EUT is connected), where permitted, terminated into a 50 Ω measuring instrument. All emission voltage and current measurements shall be made on each current-carrying conductor at the plug end of the EUT power cord by the use of mating plugs and receptacles on the LISN, if used. Equipment shall be tested with power cords that are normally supplied or recommended by the manufacturer and that have electrical and shielding characteristics that are the same as those cords normally supplied or recommended by the manufacturer. For those measurements using a LISN, the 50 Ω measuring port is terminated by a measuring instrument having 50 Ω input impedance. All other ports are terminated in 50 Ω loads.

Tabletop devices shall be placed on a platform of nominal size 1 m by 1.5 m, raised 80 cm above the reference ground plane. The vertical conducting plane or wall of an RF-shielded (screened) room shall be located 40 cm to the rear of the EUT. Floor-standing devices shall be placed either directly on the reference ground-plane or on insulating material as described in ANSI C63.4. All other surfaces of tabletop or floor-standing EUTs shall be at least 80 cm from any other grounded conducting surface, including the case or cases of one or more LISNs.

The bandwidth of the test receiver is set at 9 kHz.

8.4 Test protocol

Temperature: °C

Relative Humidity: %

Frequency	Correct Factor (dB)	Corrected Reading (dBuV)		Limit (dBuV)		Margin (dB)	
		QP	AV	QP	AV	QP	AV
-	-	-	-	-	-	-	-
-	-	-	-	-	-	-	-
-	-	-	-	-	-	-	-
-	-	-	-	-	-	-	-
-	-	-	-	-	-	-	-
-	-	-	-	-	-	-	-

Remark: 1. Correction Factor (dB) = LISN Factor (dB) + Cable Loss (dB).
 2. Margin (dB) = Limit - Corrected Reading.

9 Occupied Bandwidth

Test Status: Tested

9.1 Test limit

None

9.2 Test Configuration

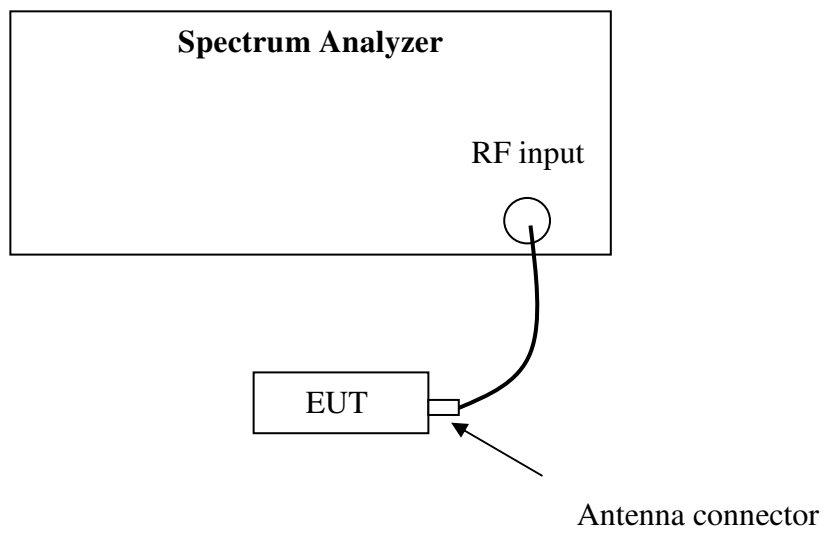

9.3 Test procedure and test setup

The bandwidth was measured from the antenna port of the EUT.

The following procedure shall be used for measuring (99 %) power bandwidth:

1. Set center frequency to the nominal EUT channel center frequency.
2. Set span = 1.5 times to 5.0 times the OBW.
3. Set RBW = 1 % to 5 % of the OBW
4. Set VBW $\geq 3 \cdot$ RBW
5. Video averaging is not permitted. Where practical, a sample detection and single sweep mode shall be used. Otherwise, peak detection and max hold mode (until the trace stabilizes) shall be used.
6. Use the 99 % power bandwidth function of the instrument (if available).
7. If the instrument does not have a 99 % power bandwidth function, the trace data points are recovered and directly summed in power units. The recovered amplitude data points, beginning at the lowest frequency, are placed in a running sum until 0.5 % of the total is reached; that frequency is recorded as the lower frequency. The process is repeated until 99.5 % of the total is reached; that frequency is recorded as the upper frequency. The 99% occupied bandwidth is the difference between these two frequencies.

9.4 Test protocol

Temperature : 22 °C

Relative Humidity : 43 %

BLE 99% Occupied Bandwidth		
Test Frequency (MHz)	99% Occupied Bandwidth (MHz)	Result
2402	1.0362	Pass
2440	1.0643	Pass
2480	1.0479	Pass

