



**EMC Technologies Pty Ltd**

ABN 82 057 105 549  
176 Harrick Road  
Keilor Park  
Victoria Australia 3042

Ph: + 613 9365 1000  
Fax: + 613 9331 7455  
email: melb@emctech.com.au

## SAR Test Report

Report Number: M110447R

**Test Sample:** UHF PTT Transmitter

**Model Number:** PAR-9180LMR4

**Tested For:** ComGroup Australia

**Date of Issue:** 4<sup>th</sup> August 2011

EMC Technologies Pty Ltd reports apply only to the specific samples tested under stated test conditions. It is the manufacturer's responsibility to assure that additional production units of this model are manufactured with identical electrical and mechanical components. EMC Technologies Pty Ltd shall have no liability for any deductions, inferences or generalisations drawn by the client or others from EMC Technologies Pty Ltd issued reports. This report shall not be used to claim, constitute or imply product endorsement by EMC Technologies Pty Ltd.



This document is issued in accordance with NATA's accreditation requirements. The results of tests, calibration and/or measurements included in this document are traceable to Australian/national standards. NATA is a signatory to the ILAC Mutual Recognition Arrangement for the mutual recognition of the equivalence of testing and calibration reports.

**CONTENTS**

- 1.0 GENERAL INFORMATION ..... 3**
- 2.0 DESCRIPTION OF DEVICE ..... 4**
  - 2.1 Description of Test Sample ..... 4
  - 2.2 Test sample Accessories ..... 4
    - 2.2.1 Battery Types.....4
    - 2.2.2 Belt Clip.....4
  - 2.3 Test Signal, Frequency and Output Power..... 4
  - 2.4 Conducted Power Measurements ..... 5
  - 2.5 Battery Status..... 5
  - 2.6 Details of Test Laboratory ..... 6
    - 2.6.1 Location .....6
    - 2.6.2 Accreditations.....6
    - 2.6.3 Environmental Factors.....6
- 3.0 DESCRIPTION OF SAR MEASUREMENT SYSTEM..... 7**
  - 3.1 Probe Positioning System ..... 7
  - 3.2 E-Field Probe Type and Performance ..... 7
  - 3.3 Data Acquisition Electronics ..... 7
  - 3.4 Calibration and Validation Procedures and Data ..... 7
    - 3.4.1 Validation Results @ 450 MHz.....7
    - 3.4.2 Deviation from reference validation values .....8
    - 3.4.3 Liquid Depth 15cm.....8
  - 3.5 Phantom Properties (Size, Shape, Shell Thickness) ..... 9
  - 3.6 Tissue Material Properties..... 9
    - 3.6.1 Liquid Temperature and Humidity.....10
  - 3.7 Simulated Tissue Composition Used for SAR Test ..... 11
  - 3.8 Device Holder for DASY5..... 11
- 4.0 SAR MEASUREMENT PROCEDURE USING DASY5..... 12**
- 5.0 MEASUREMENT UNCERTAINTY..... 13**
- 6.0 EQUIPMENT LIST AND CALIBRATION DETAILS..... 15**
- 7.0 SAR TEST METHOD..... 16**
  - 7.1 Description of the Test Positions (Face Frontal and Belt Clip)..... 16
    - 7.1.1 “Face Frontal Position” .....16
    - 7.1.2 “Belt Clip” Position.....16
  - 7.2 List of All Test Cases (Antenna In/Out, Test Frequencies, User Modes) ..... 16
  - 7.3 FCC RF Exposure Limits for Occupational/ Controlled Exposure..... 16
  - 7.4 FCC RF Exposure Limits for Un-controlled/Non-occupational ..... 16
- 8.0 SAR MEASUREMENT RESULTS ..... 17**
- 9.0 COMPLIANCE STATEMENT ..... 18**
- APPENDIX A1 Test Sample Photographs ..... 19**
- APPENDIX A2 Test Setup Photographs..... 21**
- APPENDIX A3 Test Setup Photographs..... 22**
- APPENDIX B Plots Of The SAR Measurements..... 23**
- APPENDIX C CALIBRATION DOCUMENTS..... 42**



## SAR EVALUATION

UHF PTT Transmitter, **Model:** PAR-9180LMR4 **Report Number:** M110447R

### 1.0 GENERAL INFORMATION

**Test Sample:** UHF PTT Transmitter  
**Model Number:** PAR-9180LMR4  
**Serial Number:** Production Sample  
**Manufacturer:** TMC Radio

**Device Category:** Portable Transmitter  
**Test Device:** Production Unit / Prototype Sample  
**RF exposure Category:** Occupational/ Controlled Exposure

**Tested for:** ComGroup Australia  
**Address:** 1270 Ferntree Gully Road Scoresby Vic 3179  
**Contact:** Robert Stowell  
**Phone:** +613 9730 3876  
**Fax:** +613 9370 3968  
**Email:** bstowell@comgroup.net.au

**Test Standard/s:** Evaluating Compliance with FCC Guidelines For Human Exposure to Radiofrequency Electromagnetic Fields Supplement C (Edition 01-01) to OET Bulletin 65 (Edition 97-01) Radio Frequency Exposure Compliance of Radiocommunication Apparatus (All Frequency Bands) RSS-102

**Statement Of Compliance:** The UHF PTT Transmitter, model PAR-9180LMR4 complied with the FCC occupational/controlled RF exposure limits of 8.0mW/g as per requirements of 47CFR2.1093(d).

**Test Date:** 18<sup>th</sup> May 2011

**Test Officer:**



**Peter Jakubiec**

**Authorised Signature:**



**Peter Jakubiec**

This document is issued in accordance with NATA's accreditation requirements. The results of tests, calibration and/or measurements included in this document are traceable to Australian/national standards. NATA is a signatory to the ILAC Mutual Recognition Arrangement for the mutual recognition of the equivalence of testing and calibration reports.



## 2.0 DESCRIPTION OF DEVICE

### 2.1 Description of Test Sample

The device tested was a UHF PTT transmitter fitted with Model Number PAR-9180LMR4 accessory, which is an extension Speaker/ Microphone with antenna. This equipment combination operates on the 450 MHz frequency band. This accessory has an integral fixed length antenna and was tested in the Face Frontal and Belt Clip configurations of the phantom.

Operating Mode during Testing	: Continuous Wave 100% duty cycle
Operating Mode production sample	: 50% duty cycle
Modulation:	: FM
Device Power Rating for test sample and identical production unit	: 5 W
Device Dimensions (LxWxH)	: 79mm x 62mm x 27mm (Without Antenna)
Antenna Length Compressed Helical	: 69 mm
Antenna Length Whip	: 169 mm
Antenna types	: Compressed Helical : Standard Whip
Applicable Head Configurations	: Face Frontal
Applicable Body Configurations	: Belt Clip Position
Battery Options	: 7.4V 3000mAh Li-ion Battery Pack

### 2.2 Test sample Accessories

#### 2.2.1 Battery Types

A 7.4V 3000mAh Li-ion battery pack is used to power the DUT. The maximum rated power is 5W. SAR measurements were performed with a standard 7.4V battery.

#### 2.2.2 Belt Clip

One type of plastic-metallic belt clip is sold with the device. The belt clip is fixed to the back of the device and provides a spacing of 12mm between the device and flat phantom. This plastic-metallic belt-clip was attached to the device during testing in the Belt-Clip position.

### 2.3 Test Signal, Frequency and Output Power

The DUT is a multi-channel device that operates in the 450 MHz frequency band. The frequency range is 406.1 MHz to 480 MHz. The transmitter was configured into a test mode that ensured a continuous RF transmission for the duration of each SAR scan. The device transmission characteristics were also monitored during testing to confirm the device was transmitting continuously. The device was supplied with two types of antennas, both accommodating the full operating frequency range. The whip and compressed helical antennas are designed for the ranges 406.1 MHz – 480 MHz. FCC guidelines (KDB 643646 D01 SAR Test for PTT Radios v01r01) stipulate that SAR measurements be done at the “highest channel” of the operating band (for each antenna), and if SAR is higher than 3.5 mW/g also at the adjacent channels. Due to the variations in antenna gain for different channels, deviations from the FCC guidelines were required to determine the worst case SAR channels. Determining the worst case SAR channels for the low, mid and high antennas was done using a Pre-scan. Full SAR measurements were done on the channels that were found to have the highest SAR values using the fast SAR measurement technique. There were no wires or other connections to the Handheld Transceiver during the SAR measurements.

**Table: Test Frequencies**

Frequency Range	Traffic Channels	Nominal Power (dBm)
406.1 – 480 MHz	0 - 5	37



**2.4 Conducted Power Measurements**

The conducted power of the EUT was measured in the 406.1 MHz to 480 MHz frequency range with a calibrated Power Meter. The results of this measurement are listed in table below.

**Table: Frequency and Output Power**

Channel	Channel Frequency MHz	Battery Type	Maximum Conducted Output Power dBm
1	416	Standard 7.4V Li-ion	36.05
2	432	Standard 7.4V Li-ion	36.26
3	448	Standard 7.4V Li-ion	36.67
4	464	Standard 7.4V Li-ion	35.95
5	480	Standard 7.4V Li-ion	35.66

**2.5 Battery Status**

The device battery was fully charged prior to commencement of measurement. Each SAR test was completed within 30 minutes. The battery condition was monitored by measuring the conducted RF at the antenna port before the commencement of each test and again after the completion of the test.

**Table: Battery Details**

<b>Battery #1:</b>	7.4V Li-ion Rechargeable	<b>Battery #2:</b>	7.4V Li-ion Rechargeable
<b>Model No.:</b>	PAR-9180BATL3X	<b>Model No.:</b>	PAR-9180BATL3X
<b>Serial No.:</b>	55010	<b>Serial No.:</b>	51311



## 2.6 Details of Test Laboratory

### 2.6.1 Location

EMC Technologies Pty Ltd  
176 Harrick Road  
Keilor Park, (Melbourne) Victoria  
Australia 3042

**Telephone:** +61 3 9365 1000  
**Facsimile:** +61 3 9331 7455  
**email:** [melb@emctech.com.au](mailto:melb@emctech.com.au)  
**website:** [www.emctech.com.au](http://www.emctech.com.au)

### 2.6.2 Accreditations

EMC Technologies Pty. Ltd. is accredited by the National Association of Testing Authorities, Australia (NATA). **NATA Accredited Laboratory Number: 5292**

EMC Technologies Pty Ltd is NATA accredited for the following standards:

**AS/NZS 2772.1:** RF and microwave radiation hazard measurement  
**ACA:** Radio communications (Electromagnetic Radiation - Human Exposure) Standard 2003  
**FCC:** Guidelines for Human Exposure to RF Electromagnetic Field OET65C 01/01  
**CENELEC:** ES59005: 1998  
**EN 50360: 2001** Product standard to demonstrate the compliance of mobile phones with the basic restrictions related to human exposure to electromagnetic fields (300 MHz – 3 GHz)  
**EN 62209-1:2006** Human Exposure to radio frequency fields from hand-held and body-mounted wireless communication devices - Human models instrumentation and procedures.  
**Part 1:** Procedure to determine the specific absorption rate (SAR) for hand-held devices used in close proximity to the ear (300 MHz to 3 GHz)  
**IEEE 1528: 2003** Recommended Practice for Determining the Peak Spatial-Average Specific Absorption Rate (SAR) in the Human Head Due to Wireless Communications Devices: Measurement Techniques.

Refer to NATA website [www.nata.asn.au](http://www.nata.asn.au) for the full scope of accreditation.

### 2.6.3 Environmental Factors

The measurements were performed in a shielded room with no background network signals. The temperature in the laboratory was controlled to within  $20 \pm 1$  °C, the humidity was 42%. The liquid parameters were measured prior to the commencement of the tests. Tests were performed to check that reflections within the environment did not influence the SAR measurements. The noise floor of the DASY5 SAR measurement system using the SN1380 probe is less than 5µV in both air and liquid mediums.



### 3.0 DESCRIPTION OF SAR MEASUREMENT SYSTEM

#### 3.1 Probe Positioning System

The measurements were performed with the state of the art automated near-field scanning system **DASY5 Version 52** from Schmid & Partner Engineering AG (SPEAG). The system is based on a high precision 6-axis robot (working range greater than 1.1m), which positions the SAR measurement probes with a positional repeatability of better than  $\pm 0.02$  mm. The DASY5 fully complies with the OET65 C (01-01), IEEE 1528 and EN50361 SAR measurement requirements.

#### 3.2 E-Field Probe Type and Performance

The SAR measurements were conducted with the dosimetric probe ET3DV6 Serial: 1380 (manufactured by SPEAG) designed in the classical triangular configuration and optimised for dosimetric evaluation. The probe has been calibrated and found to be accurate to better than  $\pm 0.25$  dB. The probe is suitable for measurements close to material discontinuity at the surface of the phantom. The sensors of the probe are directly loaded with Schottky diodes and connected via highly resistive lines (length = 300 mm) to the data acquisition unit.

#### 3.3 Data Acquisition Electronics

The data acquisition electronics (DAE3) consists of a highly sensitive electrometer-grade preamplifier with auto-zeroing, a channel and gain switching multiplexer, a fast 16 bit AD-converter and a command decoder and control logic unit. The input impedance of the DAE3 box is 200 M $\Omega$ ; the inputs are symmetrical and floating. Common mode rejection is above 80dB. Transmission to the PC-card is accomplished through an optical downlink for data and status information as well as an optical uplink for commands and the clock.

The mechanical probe-mounting device includes two different sensor systems for frontal and sideways probe contacts. They are used for mechanical surface detection and probe collision detection.

#### 3.4 Calibration and Validation Procedures and Data

Prior to the SAR assessment, the system validation kit was used to verify that the DASY5 was operating within its specifications. The validation was performed at 450 MHz with the SPEAG D450V3 calibrated dipole.

The validation dipoles are highly symmetric and matched at the centre frequency for the specified liquid and distance to the phantom. The accurate distance between the liquid surface and the dipole centre is achieved with a distance holder that snaps onto the dipole.

System validation is performed by feeding a known power level into a reference dipole, set at a known distance from the phantom. The measured SAR is compared to the theoretically derived level.

##### 3.4.1 Validation Results @ 450 MHz

The following table lists the dielectric properties of the tissue simulating liquid measured prior to SAR validation. The results of the validation are listed in columns 4 and 5. The forward power into the reference dipole for each SAR validation was adjusted to 400mW.

**Table: Validation Results (Dipole: SPEAG D450V3 SN: 1074)**

1. Validation Date	2. $\epsilon_r$ (measured)	3. $\sigma$ (mho/m) (measured)	4. Measured SAR 1g (mW/g)	5. Measured SAR 10g (mW/g)
18 <sup>th</sup> May 2011	44.4	0.88	2.04	1.35



**3.4.2 Deviation from reference validation values**

The reference SAR values are derived using a reference dipole and flat phantom suitable for a centre frequency of 450 MHz. These reference SAR values are obtained from the IEEE Std 1528-2003 and are normalized to 1W.

The SPEAG calibration reference SAR value is the SAR validation result obtained in a specific dielectric liquid using the validation dipole (D450V3) during calibration. The measured one-gram SAR should be within 10% of the expected target reference values shown in table below.

**Table: Deviation from reference validation values**

Frequency and Date	Measured SAR 1g (mW/g)	Measured SAR 1g (Normalized to 1W)	SPEAG Calibration reference SAR Value 1g (mW/g)	Deviation From SPEAG (%)	IEEE Std 1528 reference SAR value 1g (mW/g)	Deviation From IEEE (%)
450 MHz 17 <sup>th</sup> May 2011	2.04	5.10	4.66	9.44	4.9	4.08

NOTE: All reference validation values are referenced to 1W input power.

**3.4.3 Liquid Depth 15cm**

During the SAR measurement process the liquid level was maintained to a level of 15cm with a tolerance of ±0.5cm. The following photo shows the depth of the liquid maintained during the testing.

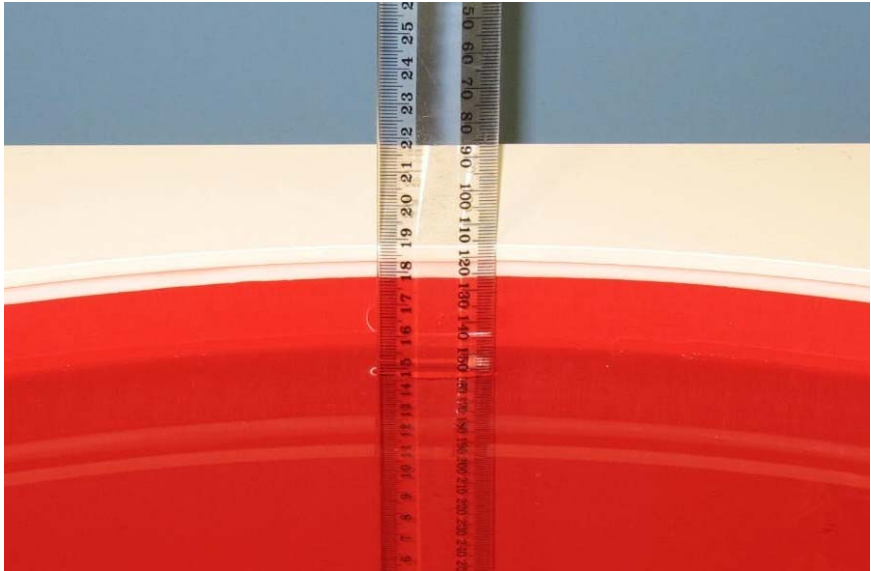

Photo of liquid Depth in Flat Phantom



### 3.5 Phantom Properties (Size, Shape, Shell Thickness)

The phantom used for system verification and SAR testing in the Face Frontal and Belt Clip positions was the ELI 4.0 flat phantom from SPEAG. The phantom thickness is 2.0mm +/-0.2 mm and the phantom was filled with the required tissue simulating liquid. Table below provides a summary of the phantom properties.

**Table: Phantom Properties**

Phantom Properties	Requirement for specific EUT
Thickness of flat section	2.0mm +/-0.2mm (flat section)
Dielectric Constant	<5.0
Loss Tangent	<0.05

Flat Phantom ELI 4.0 2mm



### 3.6 Tissue Material Properties

The dielectric parameters of the simulating liquid were measured prior to SAR assessment using the HP85070A dielectric probe kit and HP8753ES Network Analyser. The actual dielectric parameters are shown in the following table.

**Table: Measured Brain Simulating Liquid Dielectric Values**

Frequency Band	$\epsilon_r$ (measured range)	$\epsilon_r$ (target)	$\sigma$ (mho/m) (measured range)	$\sigma$ (target)	$\rho$ kg/m <sup>3</sup>
448 MHz	44.4	43.5 ±5% (41.3 – 45.7)	0.87	0.87 ±5% (0.82 – 0.91)	1000

**Table: Measured Body Simulating Liquid Dielectric Values**

Frequency Band	$\epsilon_r$ (measured range)	$\epsilon_r$ (target)	$\sigma$ (mho/m) (measured range)	$\sigma$ (target)	$\rho$ kg/m <sup>3</sup>
416 MHz	57.5	56.7 ±5% (53.9 – 59.5)	0.92	0.94 ±5% (0.89 – 0.99)	1000
432 MHz	57.2	56.7 ±5% (53.9 – 59.5)	0.94	0.94 ±5% (0.89 – 0.99)	1000
448 MHz	57.0	56.7 ±5% (53.9 – 59.5)	0.95	0.94 ±5% (0.89 – 0.99)	1000
464 MHz	56.8	56.7 ±5% (53.9 – 59.5)	0.96	0.94 ±5% (0.89 – 0.99)	1000

NOTE: The brain and muscle liquid parameters were within the required tolerances of ±5%.

### 3.6.1 Liquid Temperature and Humidity

The humidity and dielectric/ambient temperatures are recorded during the assessment of the tissue material dielectric parameters. The difference between the ambient temperature of the liquid during the dielectric measurement and the temperature during tests was less than  $|2|^\circ\text{C}$ .

**Table: Temperature and Humidity recorded for each day**

Date	Ambient Temperature ( $^\circ\text{C}$ )	Liquid Temperature ( $^\circ\text{C}$ )	Humidity (%)
18 <sup>th</sup> May 2011	20.9	20.3	42



### 3.7 Simulated Tissue Composition Used for SAR Test

The tissue simulating liquids are created prior to the SAR evaluation and often require slight modification each day to obtain the correct dielectric parameters.

**Table: Tissue Type: Brain @ 450MHz**

Volume of Liquid: 60 Litres

Approximate Composition	% By Weight
Distilled Water	38.56
Salt	3.95
Sugar	56.32
HEC	0.98
Bactericide	0.19

**Table: Tissue Type: Muscle @ 450MHz**

Volume of Liquid: 60 Litres

Approximate Composition	% By Weight
Distilled Water	51.16
Salt	1.49
Sugar	46.78
HEC	0.52
Bactericide	0.05

### 3.8 Device Holder for DASY5

The DASY5 device holder supplied by SPEAG is designed to cope with different positions given in the standard. It has two scales for the device rotation (with respect to the body axis) and the device inclination (with respect to the line between the ear openings). The rotation centres for both scales is the ear opening. Thus the device needs no repositioning when changing the angles.

The DASY5 device holder is made of low-loss material having the following dielectric parameters: relative permittivity  $\epsilon=3$  and loss tangent  $\delta=0.02$ . The amount of dielectric material has been reduced in the closest vicinity of the device, to reduce the influence of the clamp on the test results.

Refer to Appendix A for photographs of device positioning.



## 4.0 SAR MEASUREMENT PROCEDURE USING DASY5

The SAR evaluation was performed with the SPEAG DASY5 system. A summary of the procedure follows:

- a) A measurement of the conducted power value at the antenna port is used as a reference value for assessing the power drop of the EUT. Also a measurement of the SAR value at a fixed location is used. The power is measured at the start of the test and then again at the end of the test.
- b) The SAR distribution at the exposed side of the head or the flat section of the flat phantom is measured at a distance of 3.9 mm from the inner surface of the shell. The area covers the entire dimension of the head and the horizontal grid spacing is 15 mm x 15 mm. The actual Area Scan has dimensions of 120 mm x 300 mm surrounding the test device hot spot location. Based on this data, the area of the maximum absorption is determined by Spline interpolation. A pre-scan is performed for each phantom configuration to ensure that entire hot spot is identified.
- c) Around this point, a volume of 30 mm x 30 mm x 30 mm is assessed by measuring 7 x 7 x 7 points. On the basis of this data set, the spatial peak SAR value is evaluated with the following procedure:
  - (i) The data at the surface are extrapolated, since the centre of the dipoles is 2.7 mm away from the tip of the probe and the distance between the surface and the lowest measuring point is 1.3 mm. The extrapolation is based on a least square algorithm. A polynomial of the fourth order is calculated through the points in z-axis. This polynomial is then used to evaluate the points between the surface and the probe tip.
  - (ii) The maximum interpolated value is searched with a straightforward algorithm. Around this maximum the SAR values averaged over the spatial volumes (1 g and 10 g) are computed using the 3D-Spline interpolation algorithm. The 3D-Spline is composed of three one-dimensional splines with the "Not a knot"- condition (in x, y and z-direction). The volume is integrated with the trapezoidal – algorithm. One thousand points (10 x 10 x 10) are interpolated to calculate the averages.
  - (iii) All neighbouring volumes are evaluated until no neighbouring volume with a higher average value is found.
  - (iv) The SAR value at the same location as in Step (a) is again measured.



## 5.0 MEASUREMENT UNCERTAINTY

The uncertainty analysis is based on the template listed in the IEEE Std 1528-2003 for both Handset SAR tests and Validation uncertainty. The measurement uncertainty of a specific device is evaluated independently and the total uncertainty for both evaluations (95% confidence level) must be less than 30%.

**Table: Uncertainty Budget for DASY5 Version 52.6.2.424 – EUT SAR test**

Error Description	Uncert. Value	Prob. Dist.	Div.	C <sub>i</sub> (1g)	C <sub>i</sub> (10g)	1g u <sub>i</sub>	10g u <sub>i</sub>	v <sub>i</sub>
<b>Measurement System</b>								
Probe Calibration	8	N	1.00	1	1	8.00	8.00	∞
Axial Isotropy	4.7	R	1.73	0.7	0.7	1.90	1.90	∞
Hemispherical Isotropy	9.6	R	1.73	0.7	0.7	3.88	3.88	∞
Boundary Effects	1	R	1.73	1	1	0.58	0.58	∞
Linearity	4.7	R	1.73	1	1	2.71	2.71	∞
System Detection Limits	1	R	1.73	1	1	0.58	0.58	∞
Readout Electronics	0.3	N	1.00	1	1	0.30	0.30	∞
Response Time	0.8	R	1.73	1	1	0.46	0.46	∞
Integration Time	2.6	R	1.73	1	1	1.50	1.50	∞
RF Ambient Noise	3	R	1.73	1	1	1.73	1.73	∞
RF Ambient Reflections	3	R	1.73	1	1	1.73	1.73	∞
Probe Positioner	0.4	R	1.73	1	1	0.23	0.23	∞
Probe Positioning	2.9	R	1.73	1	1	1.67	1.67	∞
Max. SAR Eval.	1	R	1.73	1	1	0.58	0.58	∞
<b>Test Sample Related</b>								
Test Sample Positioning	2.9	N	1.00	1	1	2.90	2.90	145
Device Holder Uncertainty	3.6	N	1.00	1	1	3.60	3.60	5
Output Power Variation – SAR Drift Measurement	10.46	R	1.73	1	1	6.04	6.04	∞
<b>Phantom and Setup</b>								
Phantom Uncertainty	4	R	1.73	1	1	2.31	2.31	∞
Liquid Conductivity – Deviation from target values	5	R	1.73	0.64	0.43	1.85	1.24	∞
Liquid Conductivity – Measurement uncertainty	2.5	N	1.00	0.64	0.43	1.60	1.08	∞
Liquid Permittivity – Deviation from target values	5	R	1.73	0.6	0.49	1.73	1.41	∞
Liquid Permittivity – Measurement uncertainty	2.5	N	1.00	0.6	0.49	1.50	1.23	∞
Combined standard Uncertainty (u <sub>c</sub> )						13.3	13.1	
Expanded Uncertainty (95% CONFIDENCE LEVEL)				k= 2		26.6	26.2	

Estimated total measurement uncertainty for the DASY5 measurement system was ±13.3%. The extended uncertainty (K = 2) was assessed to be ±26.6% based on 95% confidence level. The uncertainty is not added to the measurement result.



**Table: Uncertainty Budget for DASY5 Version 52.6.2.424 - Validation**

Error Description	Uncert. Value	Prob. Dist.	Div.	C <sub>i</sub> (1g)	C <sub>i</sub> (10g)	1g u <sub>i</sub>	10g u <sub>i</sub>	v <sub>i</sub>
<b>Measurement System</b>								
Probe Calibration	6.65	N	1.00	1	1	6.65	6.65	∞
Axial Isotropy	4.7	R	1.73	1	1	2.71	2.71	∞
Hemispherical Isotropy	9.6	R	1.73	0	0	0.00	0.00	∞
Boundary Effects	1	R	1.73	1	1	0.58	0.58	∞
Linearity	4.7	R	1.73	1	1	2.71	2.71	∞
System Detection Limits	1	R	1.73	1	1	0.58	0.58	∞
Readout Electronics	0.3	N	1.00	1	1	0.30	0.30	∞
Response Time	0	R	1.73	1	1	0.00	0.00	∞
Integration Time	0	R	1.73	1	1	0.00	0.00	∞
RF Ambient Noise	1	R	1.73	1	1	0.58	0.58	∞
RF Ambient Reflections	1	R	1.73	1	1	0.58	0.58	∞
Probe Positioner	0.8	R	1.73	1	1	0.46	0.46	∞
Probe Positioning	6.7	R	1.73	1	1	3.87	3.87	∞
Max. SAR Eval.	2	R	1.73	1	1	1.15	1.15	∞
<b>Dipole Related</b>								
Deviation of exp. dipole	5.5	R	1.73	1	1	3.18	3.18	∞
Dipole Axis to Liquid Dist.	2	R	1.73	1	1	1.15	1.15	∞
Input power & SAR drift	5.00	R	1.73	1	1	2.89	2.89	∞
<b>Phantom and Setup</b>								
Phantom Uncertainty	4	R	1.73	1	1	2.31	2.31	∞
SAR Correction	1.9	R	1.73	1	0.84	1.10	0.92	∞
Liquid Conductivity (meas.)	2.5	N	1.00	0.78	0.71	1.95	1.78	∞
Liquid Permittivity (meas.)	2.5	N	1.00	0.26	0.26	0.65	0.65	∞
Temp. unc. - Conductivity	1.7	R	1.73	0.78	0.71	0.77	0.70	∞
Temp. unc. - Permittivity	0.3	R	1.73	0.23	0.26	0.04	0.05	∞
Combined standard Uncertainty (u <sub>c</sub> )						10.4	10.3	
Expanded Uncertainty (95% CONFIDENCE LEVEL)				k= 2		20.8	20.7	

Estimated total measurement uncertainty for the DASY5 measurement system was  $\pm 10.4\%$ . The extended uncertainty (K = 2) was assessed to be  $\pm 20.8\%$  based on 95% confidence level. The uncertainty is not added to the Validation measurement result.



## 6.0 EQUIPMENT LIST AND CALIBRATION DETAILS

**Table: SPEAG DASY5 Version 52**

Equipment Type	Manufacturer	Model Number	Serial Number	Calibration Due	Used For this Test?
Robot - Six Axes	Staubli	RX90BL	N/A	Not applicable	✓
Robot Remote Control	SPEAG	CS7MB	RX90B	Not applicable	✓
SAM Phantom	SPEAG	N/A	1260	Not applicable	
SAM Phantom	SPEAG	N/A	1060	Not applicable	
Flat Phantom	AndreT	10.1	P 10.1	Not Applicable	
Flat Phantom	AndreT	9.1	P 9.1	Not Applicable	
Flat Phantom	SPEAG	ELI 4.0	1101	Not Applicable	✓
Data Acquisition Electronics	SPEAG	DAE3 V1	359	07-July-2011	
Data Acquisition Electronics	SPEAG	DAE3 V1	442	09-Dec-2011	✓
Probe E-Field - Dummy	SPEAG	DP1	N/A	Not applicable	
Probe E-Field	SPEAG	ET3DV6	1380	09-Dec-2011	✓
Probe E-Field	SPEAG	ET3DV6	1377	7-July-2011	
Probe E-Field	SPEAG	ES3DV6	3029	Not Used	
Probe E-Field	SPEAG	EX3DV4	3563	16-July-2011	
Probe E-Field	SPEAG	EX3DV4	3657	13-Dec-2011	
Antenna Dipole 300 MHz	SPEAG	D300V3	1012	30-Nov-2012	
Antenna Dipole 450 MHz	SPEAG	D450V3	1074	30-Nov-2012	✓
Antenna Dipole 900 MHz	SPEAG	D900V2	047	5-July-2012	
Antenna Dipole 1640 MHz	SPEAG	D1640V2	314	9-July-2012	
Antenna Dipole 1800 MHz	SPEAG	D1800V2	242	13-July-2012	
Antenna Dipole 1950 MHz	SPEAG	D1950V3	1113	10-Dec -2012	
Antenna Dipole 3500 MHz	SPEAG	D3500V2	1002	17-July-2010	
Antenna Dipole 2450 MHz	SPEAG	D2450V2	724	09-Dec-2012	
Antenna Dipole 5600 MHz	SPEAG	D5GHzV2	1008	16-Dec-2011	
RF Amplifier	EIN	603L	N/A	*In test	✓
RF Amplifier	Mini-Circuits	ZHL-42	N/A	*In test	
RF Amplifier	Mini-Circuits	ZVE-8G	N/A	*In test	
Synthesized signal generator	Hewlett Packard	ESG-D3000A	GB37420238	*In test	✓
RF Power Meter	Hewlett Packard	437B	3125012786	9-Aug-2011	✓
RF Power Sensor 0.01 - 18 GHz	Hewlett Packard	8481H	1545A01634	13-Aug-2011	✓
RF Power Meter	Rohde & Schwarz	NRP	101415	5-May-2011	
RF Power Sensor	Rohde & Schwarz	NRP - Z81	100174	16-July-2011	
RF Power Meter Dual	Hewlett Packard	435A	1733A05847	*In test	✓
RF Power Sensor	Hewlett Packard	8482A	2349A10114	*In test	✓
Network Analyser	Hewlett Packard	8714B	GB3510035	22-Sept-2011	
Network Analyser	Hewlett Packard	8753ES	JP39240130	10-Nov-2011	✓
Dual Directional Coupler	Hewlett Packard	778D	1144 04700	*In test	✓
Dual Directional Coupler	NARDA	3022	75453	*In test	

\* Calibrated during the test for the relevant parameters.



This document must not be copied or reproduced, except in full without the written permission of the Manager, EMC Technologies Pty Ltd. The certificate on page 3 may be reproduced in full.  
www.emctech.com.au

## 7.0 SAR TEST METHOD

### 7.1 Description of the Test Positions (Face Frontal and Belt Clip)

SAR measurements were performed in the “Face Frontal” and “Belt Clip” positions. Both the “Face Frontal” and “Belt Clip” positions were measured in the flat section of the SPEAG ELI 4.0 phantom. See Appendix A for photos of test positions.

#### 7.1.1 “Face Frontal Position”

The SAR evaluation was performed in the flat section of the SPEAG ELI 4.0 phantom. The device was placed 25mm from the phantom, this position is equivalent to the device placed in front of the nose. The supporting hand was not used.

#### 7.1.2 “Belt Clip” Position

The device was tested in the (2.00 mm) flat section of the SPEAG ELI 4.0 phantom for the “Belt Clip” position. A belt clip maintained a distance of approximately 12mm between the back of the device and the flat phantom. The Transceiver was placed at the flat section of the phantom and suspended until the Belt Clip touched the phantom. The belt clip was made of plastic and contained metallic parts. The device was connected with the hands free earpiece/microphone.

### 7.2 List of All Test Cases (Antenna In/Out, Test Frequencies, User Modes)

The device has a fixed antenna. The SAR was measured at three test channels with the test sample operating at maximum power, as specified in section 2.3.

### 7.3 FCC RF Exposure Limits for Occupational/ Controlled Exposure

Spatial Peak SAR Limits For:	
Partial-Body:	8.0 mW/g (averaged over any 1g cube of tissue)
Hands, Wrists, Feet and Ankles:	20.0 mW/g (averaged over 10g cube of tissue)

### 7.4 FCC RF Exposure Limits for Un-controlled/Non-occupational

Spatial Peak SAR Limits For:	
Partial-Body:	1.6 mW/g (averaged over any 1g cube of tissue)
Hands, Wrists, Feet and Ankles:	4.0 mW/g (averaged over 10g cube of tissue)





## 8.0 SAR MEASUREMENT RESULTS

The SAR values averaged over 1 g tissue mass were determined for the sample device for the Face Frontal and Belt Clip configurations of the phantom.

**Table: SAR MEASUREMENT RESULTS– Face Frontal and Belt Clip positions**

1. Test Position	2. Plot No.	3. Test Channel	4. Test Freq (MHz)	5. Antenna	6. Measured 1g SAR Results (mW/g)	6.1 Measured 1g SAR Results 50% Duty Cycle (mW/g)	7. Measured Drift (dB)
Face Frontal	1	3	448	Helical	3.45	1.725	-0.45
	2	3	448	Whip	3.26	1.63	-0.48
Belt Clip	3	1	416	Helical	6.55	3.275	-0.12
	4	2	432	Helical	8.33	4.165	-0.15
	5	3	448	Helical	<b>8.73</b>	<b>4.365</b>	-0.43
	6	4	464	Helical	4.71	2.355	-0.19
	7	3	448	Whip	6.77	3.385	-0.38

Note: The uncertainty of the system ( $\pm 26.6\%$ ) has not been added to the results.

**Table: PRE-SCAN RESULTS**

1. Test Position	2. Plot No.	3. Test Channel	4. Test Freq (MHz)	5. Antenna	6. Measured 1g SAR Results (mW/g)
Face Frontal	8	1	416	Helical	1.65
		2	432	Helical	2.55
		3	448	Helical	3.37
		4	464	Helical	1.95
		5	480	Helical	1.94
Face Frontal	9	1	416	Whip	2.59
		2	432	Whip	2.77
		3	448	Whip	3.46
		4	464	Whip	3.17
		5	480	Whip	3.04

Note: The uncertainty of the system ( $\pm 26.6\%$ ) has not been added to the results.

The FCC SAR limit for occupational exposure is 8.0 mW/g measured in a 1g cube of tissue.



## 9.0 COMPLIANCE STATEMENT

The UHF PTT Transmitter model PAR-9180LMR4 was tested on behalf of ComGroup Australia. It complied with the FCC and IC SAR requirements.

The highest SAR level recorded was 8.73 mW/g for a 1g cube. After extrapolating to a 50% duty cycle the highest SAR level recorded was 4.365 mW/g for a 1g cube. This value was measured in the "Belt Clip" position, and was below the controlled limit of 8.0 mW/g, even taking into account the measurement uncertainty of 26.6 %.

This document is issued in accordance with NATA's accreditation requirements. The results of tests, calibration and/or measurements included in this document are traceable to Australian/national standards. NATA is a signatory to the ILAC Mutual Recognition Arrangement for the mutual recognition of the equivalence of testing and calibration reports.



---

This document must not be copied or reproduced, except in full without the written permission of the Manager, EMC Technologies Pty Ltd. The certificate on page 3 may be reproduced in full.  
[www.emctech.com.au](http://www.emctech.com.au)

### APPENDIX A1 Test Sample Photographs

Battery 1



Battery 2



DUT



DUT



Host Transmitter Model: SRP9180 TU



Host Transmitter Model: SRP9180 TU



## APPENDIX A2 Test Setup Photographs

Face Frontal (Helical)



Face Frontal (Whip)



## APPENDIX A3 Test Setup Photographs

Belt Clip Position (Helical)

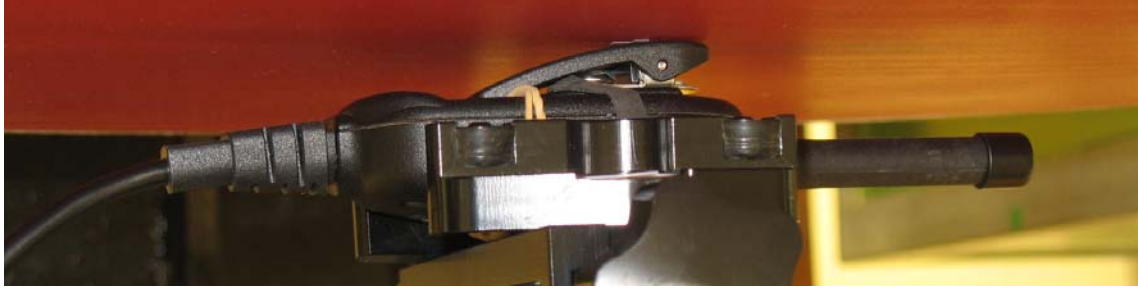

Belt Clip Position (Whip)



## APPENDIX B Plots Of The SAR Measurements

Plots of the measured SAR distributions inside the phantom are given in this Appendix for all tested configurations. The spatial peak SAR values were assessed with the procedure described in this report.

**Table: SAR Measurement Plot Numbers**

Test Position	Plot Number	Test Channel
Face Frontal	1	3
	2	3
Belt Clip	3	1
	4	2
	5	3
	6	4
	7	3

**Table: Pre-scan Plot Numbers**

Test Position	Plot Number	Test Channel
Face Frontal	8	0 – 5
	9	0 – 5

**Table: Validation Plot Numbers**

Date	Plot Number	Frequency
18 <sup>th</sup> May 2011	10	450 MHz



Test Date: 18 May 2011

File Name: M110447R 450 MHz Face Frontal Helical Antenna 18-05-11.da52:0

DUT: TMC Radio PTT RF SPK/MIC; Type: PAR-9180 LMR4; Serial: Prototype

- \* Communication System: Simoco (TMC Radio) PTT; Frequency: 448.025 MHz; Duty Cycle: 1:1
- \* Medium parameters used:  $f = 447.6$  MHz;  $\sigma = 0.874$  mho/m;  $\epsilon_r = 44.435$ ;  $\rho = 1000$  kg/m<sup>3</sup>
- Electronics: DAE3 Sn442; Probe: ET3DV6 - SN1380; ConvF(6.95, 6.95, 6.95)
- Phantom: ELI 4.0; Serial: 1101; Phantom section: Flat Section

**Configuration/Channel 3 Test/Area Scan (71x161x1):** Measurement grid:

dx=15mm, dy=15mm

Maximum value of SAR (interpolated) = 3.640 mW/g

**Configuration/Channel 3 Test/Zoom Scan (7x7x7)/Cube 0:** Measurement

grid: dx=5mm, dy=5mm, dz=5mm

Reference Value = 63.714 V/m; Power Drift = -0.11 dB

Peak SAR (extrapolated) = 4.878 W/kg

**SAR(1 g) = 3.45 mW/g; SAR(10 g) = 2.52 mW/g**

Maximum value of SAR (measured) = 3.622 mW/g

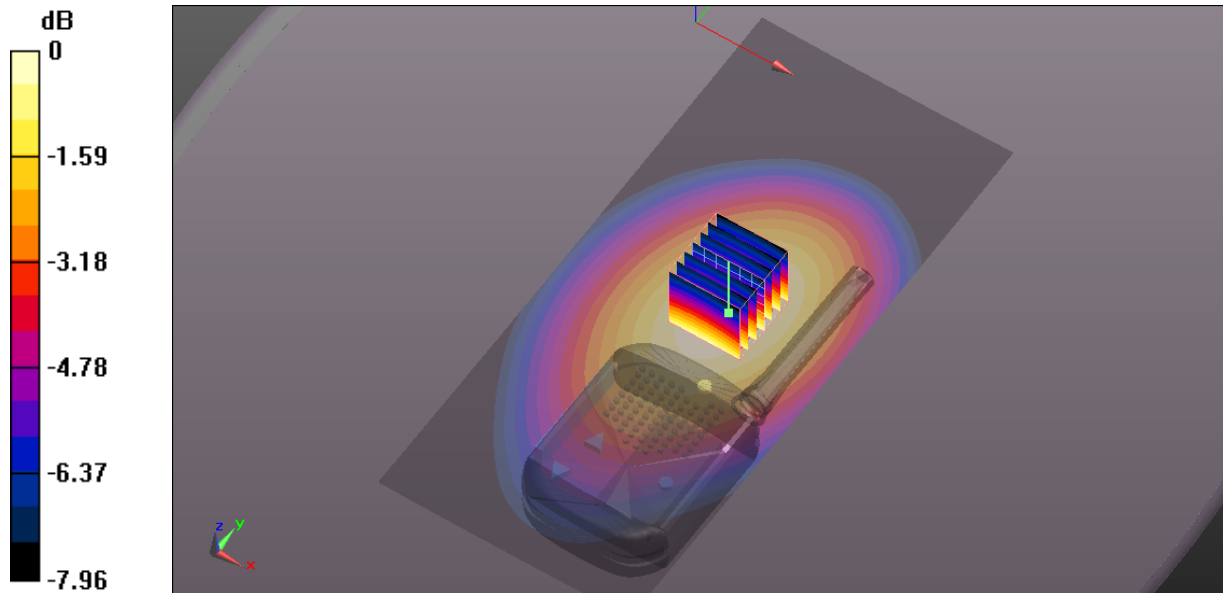

**SAR MEASUREMENT PLOT 1**

Ambient Temperature  
Liquid Temperature  
Humidity

20.9 Degrees Celsius  
20.3 Degrees Celsius  
42 %





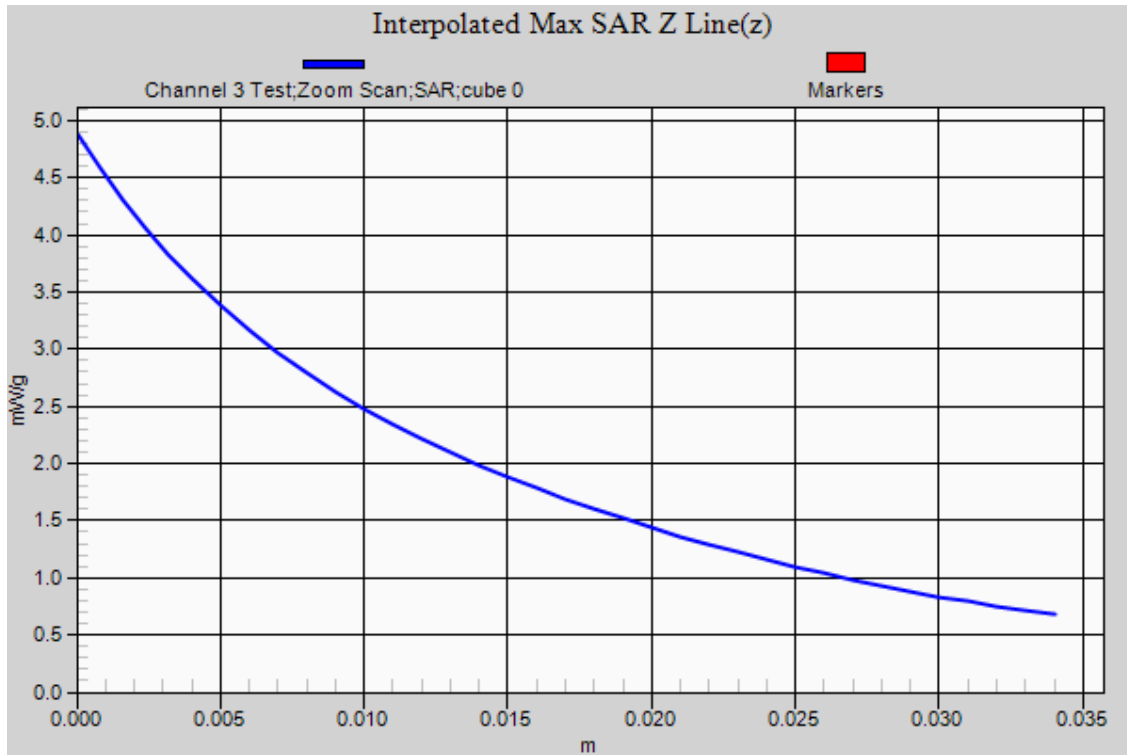

Test Date: 18 May 2011

File Name: M110447R 450 MHz Face Frontal Whip Antenna 18-05-11.da52:0

DUT: TMC Radio PTT RF SPK/MIC; Type: PAR-9180 LMR4; Serial: Prototype

- \* Communication System: Simoco (TMC Radio) PTT; Frequency: 448.025 MHz; Duty Cycle: 1:1
- \* Medium parameters used:  $f = 447.6$  MHz;  $\sigma = 0.874$  mho/m;  $\epsilon_r = 44.435$ ;  $\rho = 1000$  kg/m<sup>3</sup>
- Electronics: DAE3 Sn442; Probe: ET3DV6 - SN1380; ConvF(6.95, 6.95, 6.95)
- Phantom: ELI 4.0; Serial: 1101; Phantom section: Flat Section

**Configuration/Channel 3 Test/Area Scan (81x201x1):** Measurement grid:

dx=15mm, dy=15mm

Maximum value of SAR (interpolated) = 3.481 mW/g

**Configuration/Channel 3 Test/Zoom Scan (7x7x7)/Cube 0:** Measurement

grid: dx=5mm, dy=5mm, dz=5mm

Reference Value = 47.037 V/m; Power Drift = -0.16 dB

Peak SAR (extrapolated) = 4.614 W/kg

**SAR(1 g) = 3.26 mW/g; SAR(10 g) = 2.38 mW/g**

Maximum value of SAR (measured) = 3.450 mW/g

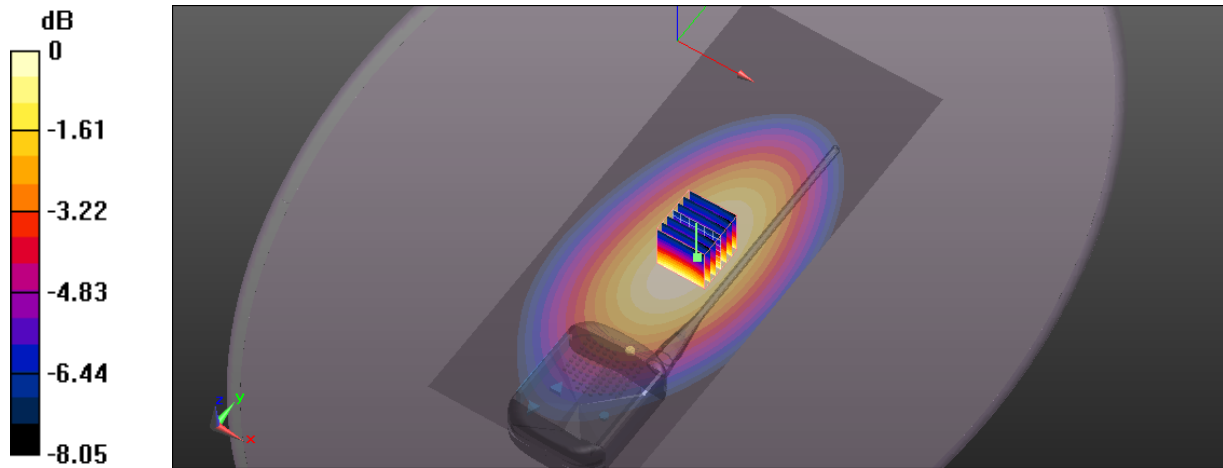

0 dB = 3.450mW/g

**SAR MEASUREMENT PLOT 2**

Ambient Temperature  
Liquid Temperature  
Humidity

20.9 Degrees Celsius  
20.3 Degrees Celsius  
42 %



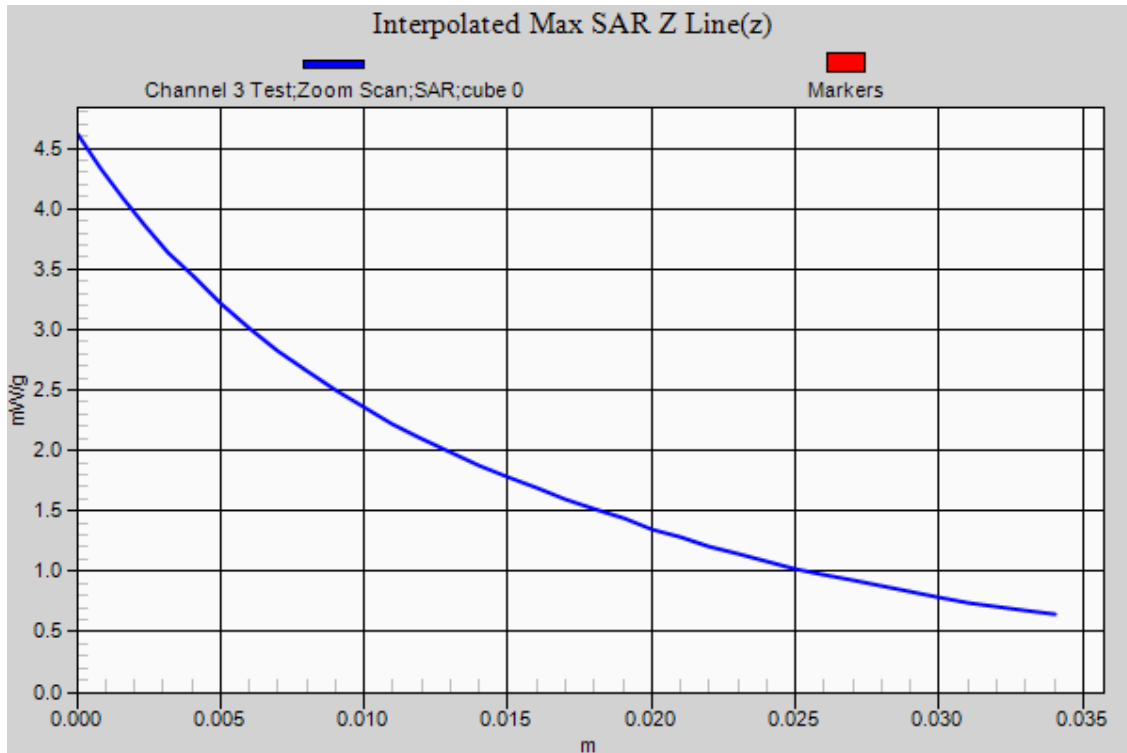

Test Date: 18 May 2011

File Name: M110447R 450 MHz Belt Clip Hellical Antenna 18-05-11.da52:0

DUT: TMC Radio PTT RF SPK/MIC; Type: PAR-9180 LMR4; Serial: Prototype

- \* Communication System: Simoco (TMC Radio) PTT; Frequency: 416.025 MHz; Duty Cycle: 1:1
- \* Medium parameters used:  $f = 415.4$  MHz;  $\sigma = 0.922$  mho/m;  $\epsilon_r = 57.529$ ;  $\rho = 1000$  kg/m<sup>3</sup>
- Electronics: DAE3 Sn442; Probe: ET3DV6 - SN1380; ConvF(7.31, 7.31, 7.31)
- Phantom: ELI 4.0; Serial: 1101; Phantom section: Flat Section

**Configuration/Channel 1 Test/Area Scan (71x161x1):** Measurement grid:

dx=15mm, dy=15mm  
Maximum value of SAR (interpolated) = 7.120 mW/g

**Configuration/Channel 1 Test/Zoom Scan (7x7x7)/Cube 0:** Measurement

grid: dx=5mm, dy=5mm, dz=5mm  
Reference Value = 89.640 V/m; Power Drift = -0.31 dB  
Peak SAR (extrapolated) = 10.067 W/kg  
**SAR(1 g) = 6.55 mW/g; SAR(10 g) = 4.54 mW/g**  
Maximum value of SAR (measured) = 6.883 mW/g

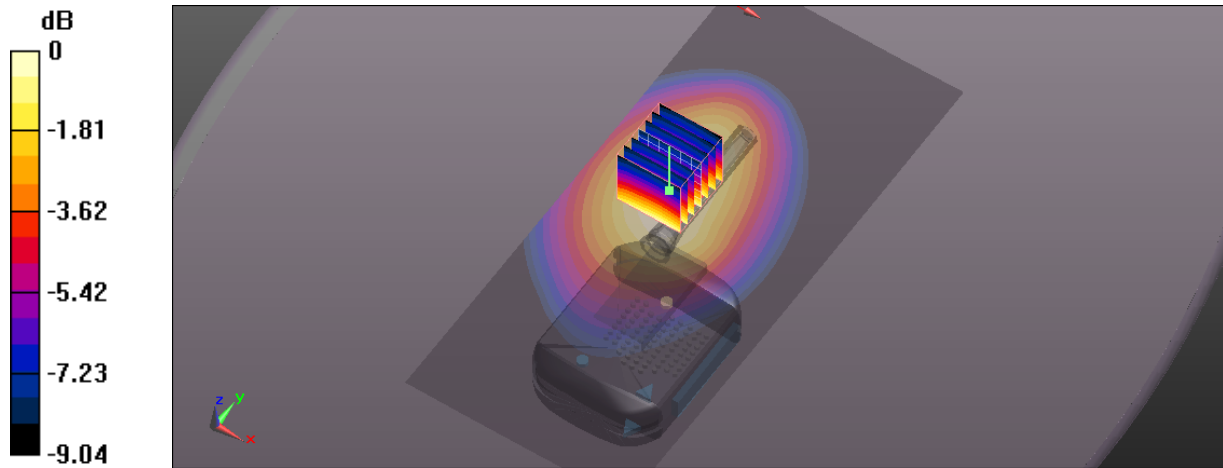

0 dB = 6.880mW/g

SAR MEASUREMENT PLOT 3

Ambient Temperature  
Liquid Temperature  
Humidity

20.9 Degrees Celsius  
20.3 Degrees Celsius  
42 %



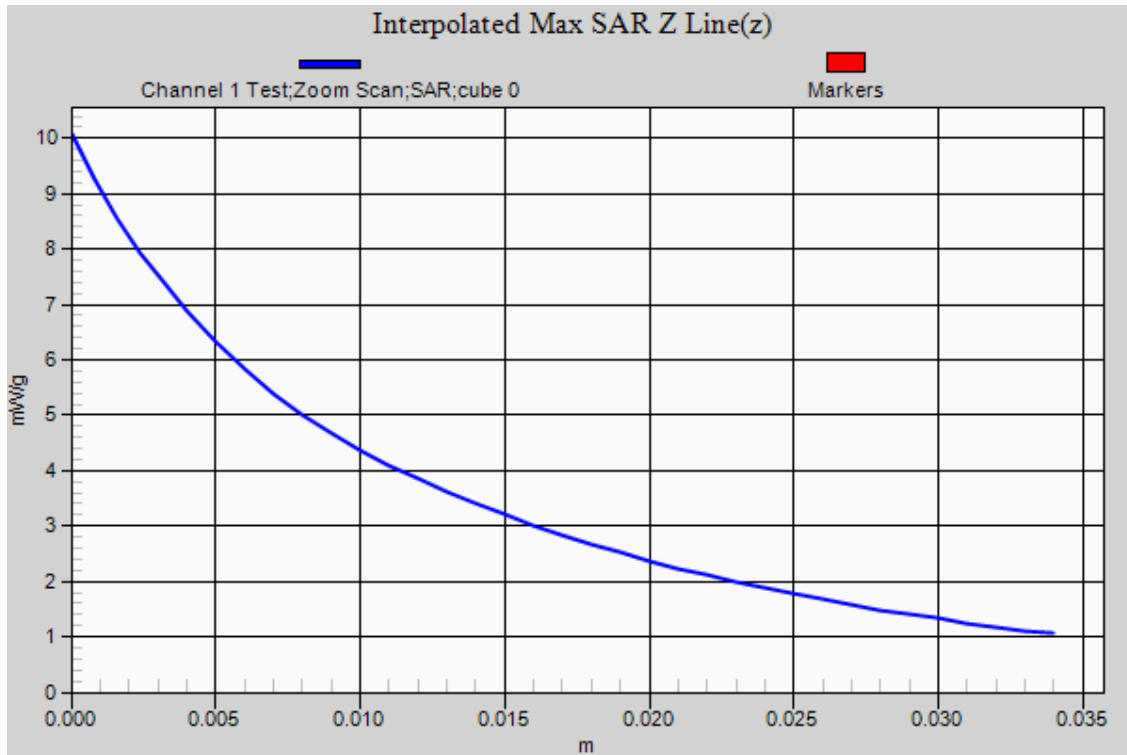

Test Date: 18 May 2011

File Name: M110447R 450 MHz Belt Clip Hellical Antenna 18-05-11.da52:0

DUT: TMC Radio PTT RF SPK/MIC; Type: PAR-9180 LMR4; Serial: Prototype

- \* Communication System: Simoco (TMC Radio) PTT; Frequency: 432.025 MHz; Duty Cycle: 1:1
- \* Medium parameters used:  $f = 432.2$  MHz;  $\sigma = 0.936$  mho/m;  $\epsilon_r = 57.256$ ;  $\rho = 1000$  kg/m<sup>3</sup>
- Electronics: DAE3 Sn442; Probe: ET3DV6 - SN1380; ConvF(7.31, 7.31, 7.31)
- Phantom: ELI 4.0; Serial: 1101; Phantom section: Flat Section

**Configuration/Channel 2 Test/Area Scan (71x161x1):** Measurement grid:

dx=15mm, dy=15mm

Maximum value of SAR (interpolated) = 8.847 mW/g

**Configuration/Channel 2 Test/Zoom Scan (7x7x7)/Cube 0:** Measurement

grid: dx=5mm, dy=5mm, dz=5mm

Reference Value = 97.751 V/m; Power Drift = -0.11 dB

Peak SAR (extrapolated) = 12.819 W/kg

**SAR(1 g) = 8.33 mW/g; SAR(10 g) = 5.8 mW/g**

Maximum value of SAR (measured) = 8.830 mW/g

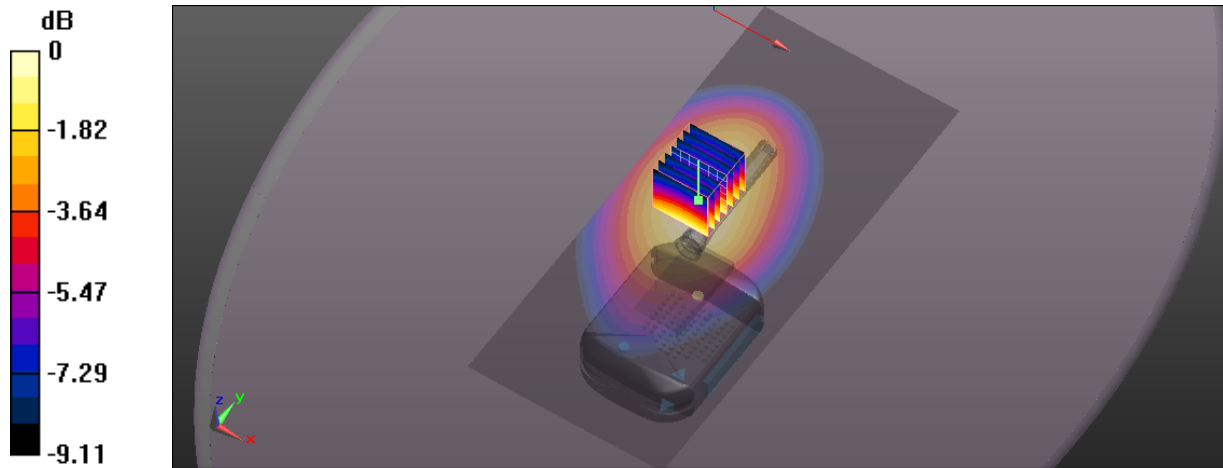

0 dB = 8.830mW/g

**SAR MEASUREMENT PLOT 4**

Ambient Temperature  
Liquid Temperature  
Humidity

20.9 Degrees Celsius  
20.3 Degrees Celsius  
42 %



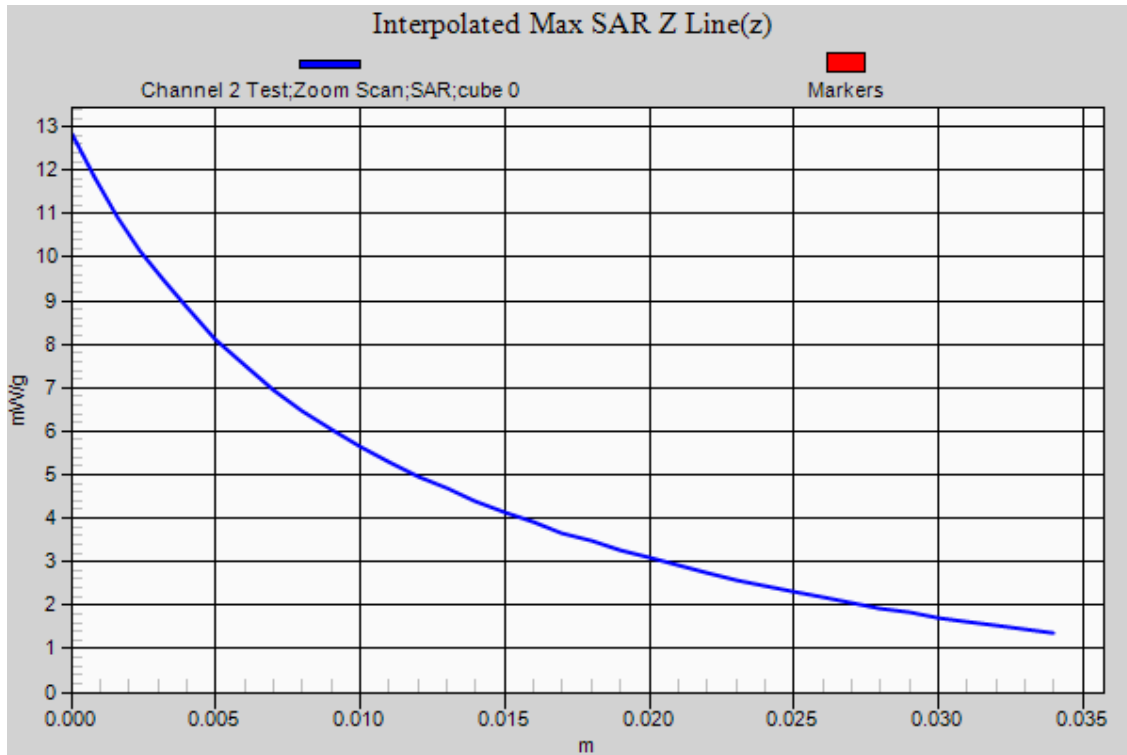

Test Date: 18 May 2011

File Name: M110447R 450 MHz Belt Clip Hellical Antenna 18-05-11.da52:0

DUT: TMC Radio PTT RF SPK/MIC; Type: PAR-9180 LMR4; Serial: Prototype

- \* Communication System: Simoco (TMC Radio) PTT; Frequency: 448.025 MHz; Duty Cycle: 1:1
- \* Medium parameters used:  $f = 447.6$  MHz;  $\sigma = 0.949$  mho/m;  $\epsilon_r = 56.971$ ;  $\rho = 1000$  kg/m<sup>3</sup>
- Electronics: DAE3 Sn442; Probe: ET3DV6 - SN1380; ConvF(7.31, 7.31, 7.31)
- Phantom: ELI 4.0; Serial: 1101; Phantom section: Flat Section

**Configuration/Channel 3 Test/Area Scan (71x161x1):** Measurement grid:

dx=15mm, dy=15mm  
 Maximum value of SAR (interpolated) = 9.315 mW/g

**Configuration/Channel 3 Test/Zoom Scan (7x7x7)/Cube 0:** Measurement

grid: dx=5mm, dy=5mm, dz=5mm  
 Reference Value = 98.806 V/m; Power Drift = -0.10 dB  
 Peak SAR (extrapolated) = 13.524 W/kg  
**SAR(1 g) = 8.73 mW/g; SAR(10 g) = 5.99 mW/g**  
 Maximum value of SAR (measured) = 9.175 mW/g

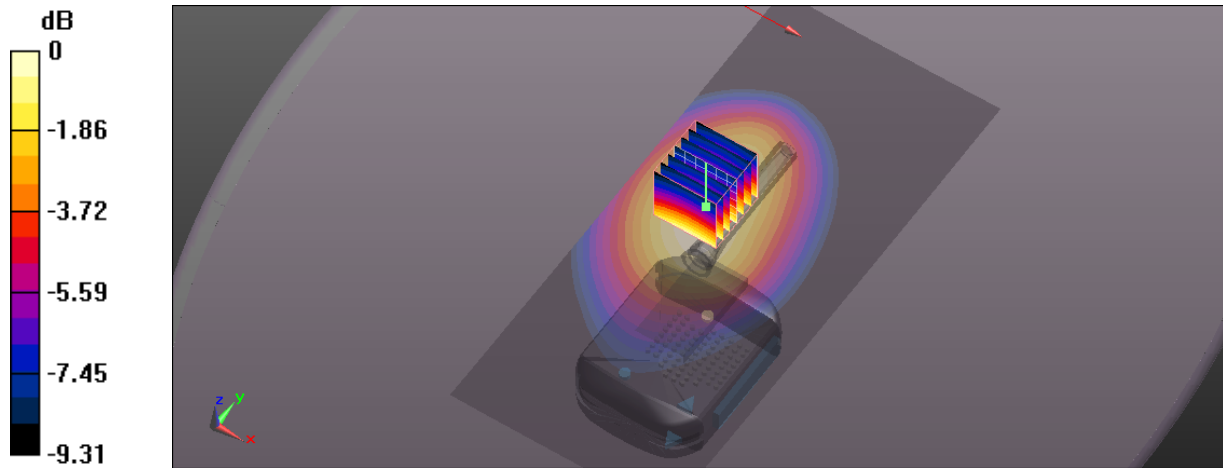

0 dB = 9.180mW/g

SAR MEASUREMENT PLOT 5

Ambient Temperature  
 Liquid Temperature  
 Humidity

20.9 Degrees Celsius  
 20.3 Degrees Celsius  
 42 %





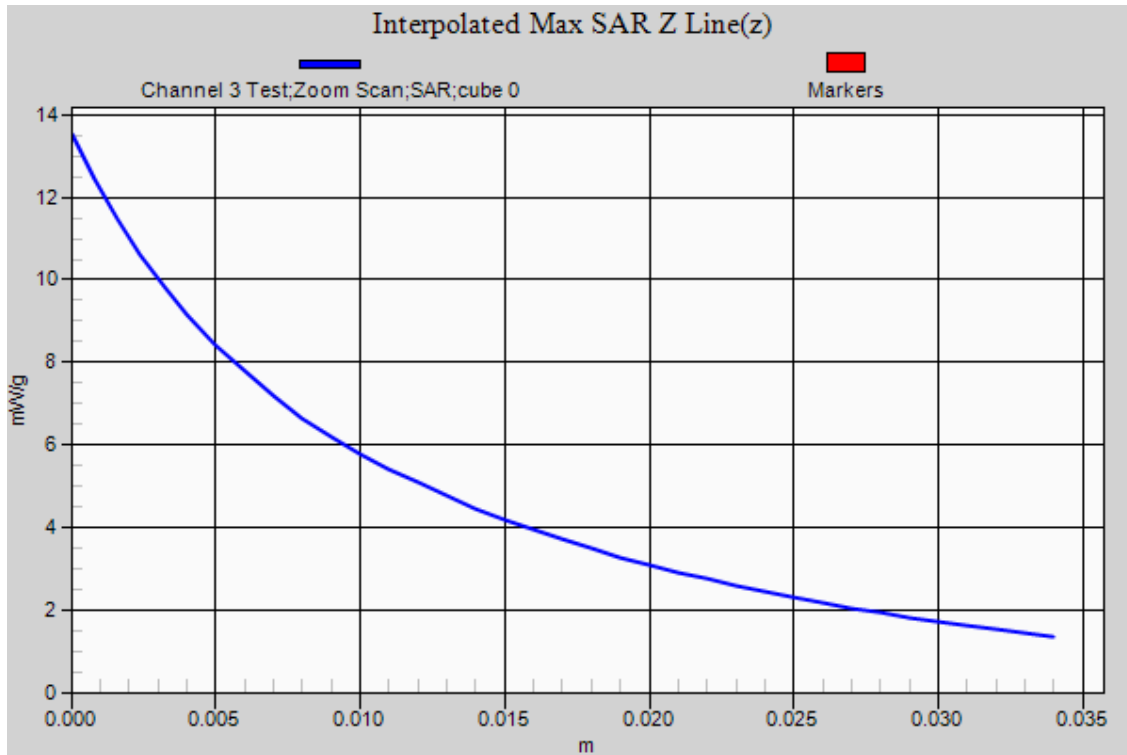

Test Date: 18 May 2011

File Name: M110447R 450 MHz Belt Clip Hellical Antenna 18-05-11.da52:0

DUT: TMC Radio PTT RF SPK/MIC; Type: PAR-9180 LMR4; Serial: Prototype

- \* Communication System: Simoco (TMC Radio) PTT; Frequency: 464.025 MHz; Duty Cycle: 1:1
- \* Medium parameters used:  $f = 464.4$  MHz;  $\sigma = 0.964$  mho/m;  $\epsilon_r = 56.764$ ;  $\rho = 1000$  kg/m<sup>3</sup>
- Electronics: DAE3 Sn442; Probe: ET3DV6 - SN1380; ConvF(7.31, 7.31, 7.31)
- Phantom: ELI 4.0; Serial: 1101; Phantom section: Flat Section

**Configuration/Channel 4 Test/Area Scan (71x161x1):** Measurement grid:

dx=15mm, dy=15mm  
 Maximum value of SAR (interpolated) = 5.020 mW/g

**Configuration/Channel 4 Test/Zoom Scan (7x7x7)/Cube 0:** Measurement

grid: dx=5mm, dy=5mm, dz=5mm  
 Reference Value = 71.099 V/m; Power Drift = -0.07 dB  
 Peak SAR (extrapolated) = 7.313 W/kg  
**SAR(1 g) = 4.71 mW/g; SAR(10 g) = 3.22 mW/g**  
 Maximum value of SAR (measured) = 4.955 mW/g

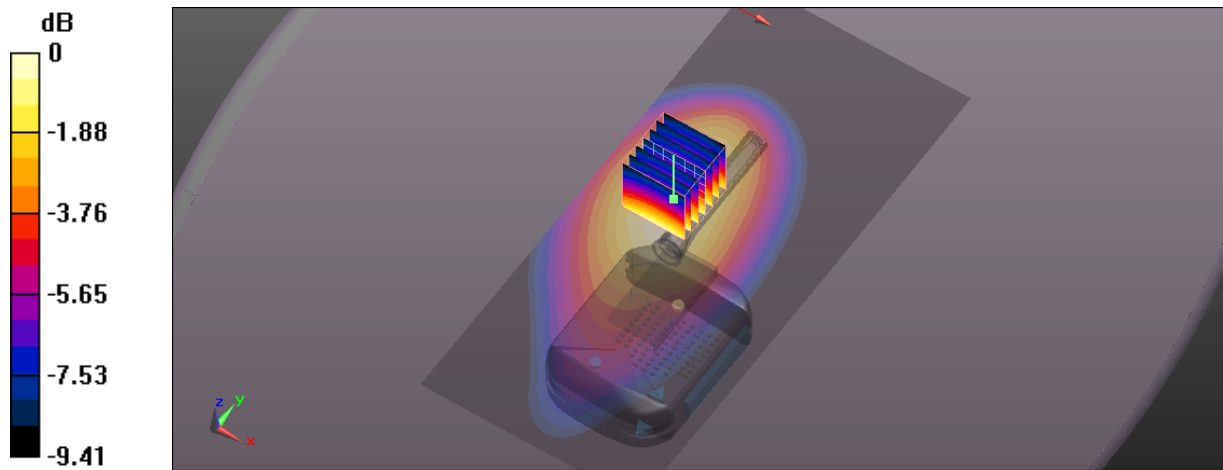

0 dB = 4.950mW/g

SAR MEASUREMENT PLOT 6

Ambient Temperature  
 Liquid Temperature  
 Humidity

20.9 Degrees Celsius  
 20.3 Degrees Celsius  
 42 %



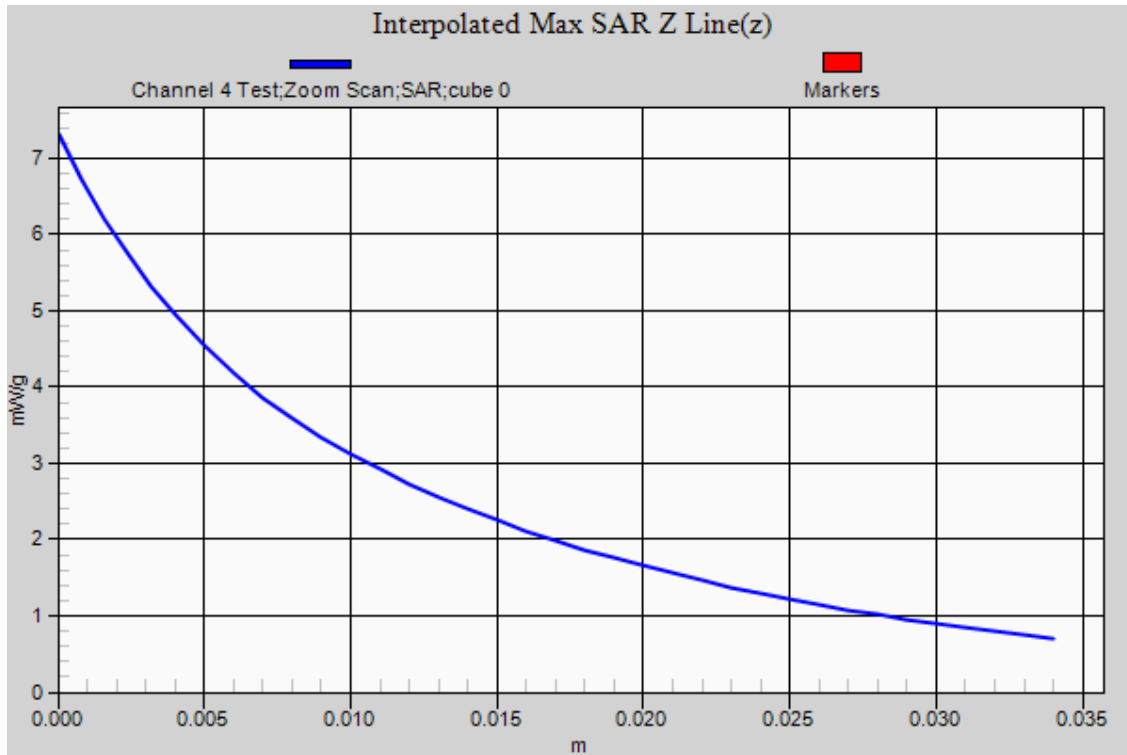

Test Date: 18 May 2011

File Name: M110447R 450 MHz Belt Clip Whip Antenna 18-05-11.da52:0

DUT: TMC Radio PTT RF SPK/MIC; Type: PAR-9180 LMR4; Serial: Prototype

- \* Communication System: Simoco (TMC Radio) PTT; Frequency: 448.025 MHz; Duty Cycle: 1:1
- \* Medium parameters used:  $f = 447.6$  MHz;  $\sigma = 0.949$  mho/m;  $\epsilon_r = 56.971$ ;  $\rho = 1000$  kg/m<sup>3</sup>
- Electronics: DAE3 Sn442; Probe: ET3DV6 - SN1380; ConvF(7.31, 7.31, 7.31)
- Phantom: ELI 4.0; Serial: 1101; Phantom section: Flat Section

**Configuration/Channel 3 Test/Area Scan (81x201x1):** Measurement grid:

dx=15mm, dy=15mm  
 Maximum value of SAR (interpolated) = 7.397 mW/g

**Configuration/Channel 3 Test/Zoom Scan (7x7x7)/Cube 0:** Measurement

grid: dx=5mm, dy=5mm, dz=5mm  
 Reference Value = 65.644 V/m; Power Drift = -0.22 dB  
 Peak SAR (extrapolated) = 10.295 W/kg  
**SAR(1 g) = 6.77 mW/g; SAR(10 g) = 4.74 mW/g**  
 Maximum value of SAR (measured) = 7.108 mW/g

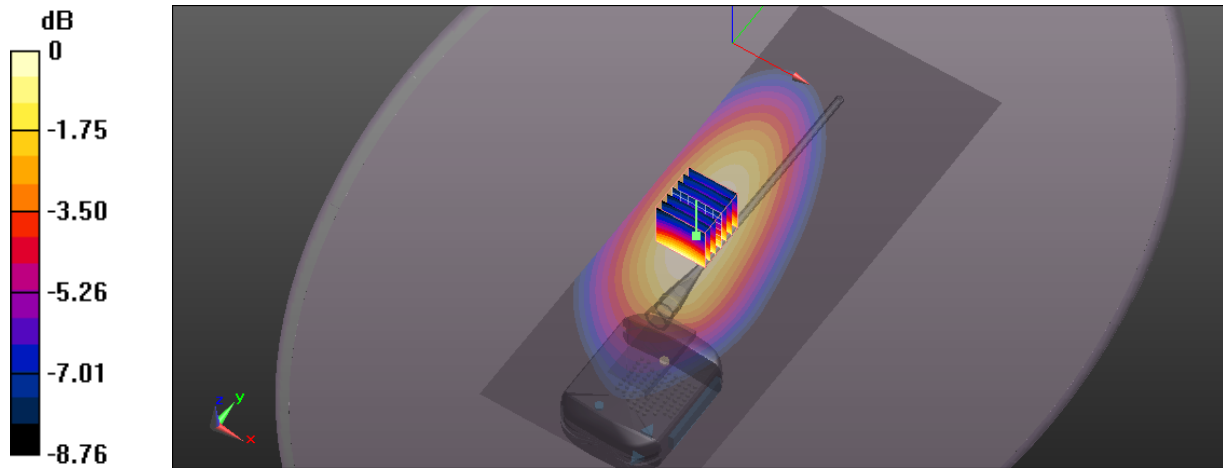

0 dB = 7.110mW/g

SAR MEASUREMENT PLOT 7

Ambient Temperature  
 Liquid Temperature  
 Humidity

20.9 Degrees Celsius  
 20.3 Degrees Celsius  
 42 %



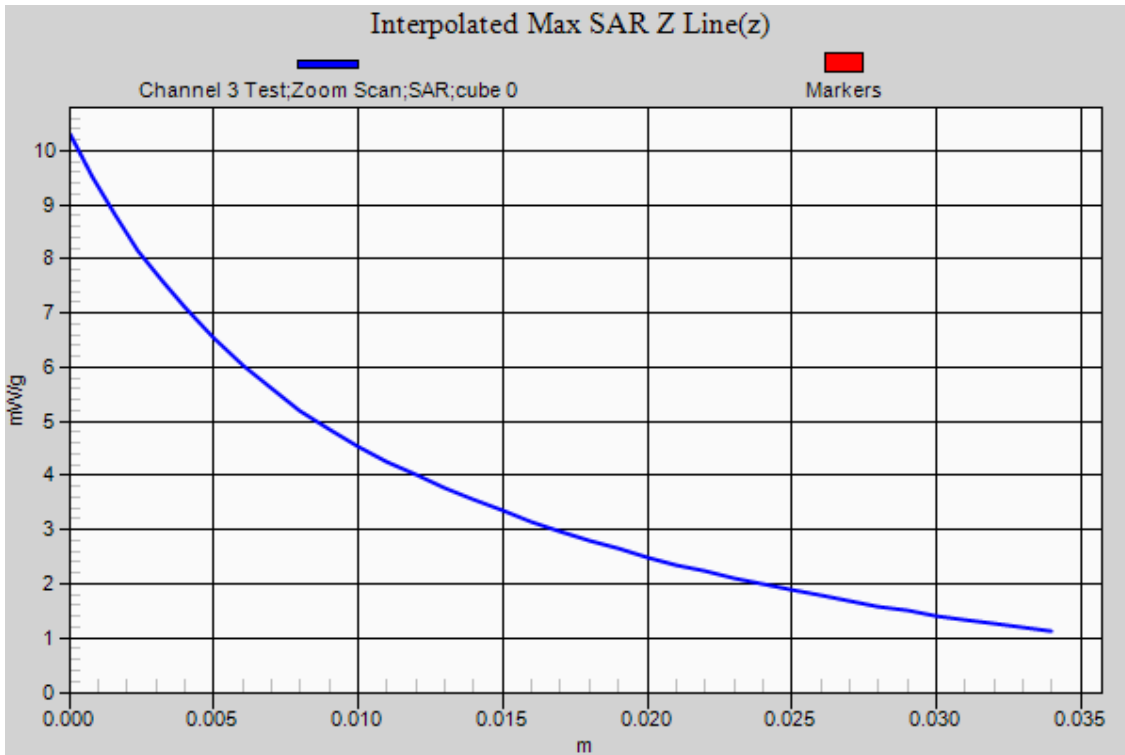

Test Date: 18 May 2011

File Name: M110447R 450 MHz Face Frontal Helical Antenna 18-05-11.da52:0

DUT: TMC Radio PTT RF SPK/MIC; Type: PAR-9180 LMR4; Serial: Prototype

\* Communication System: Simoco (TMC Radio) PTT, Frequency: 416.025 MHz, Frequency: 432.025 MHz, Frequency: 448.025 MHz, Frequency: 464.025 MHz, Frequency: 479.975 MHz; Duty Cycle: 1:1

\* Medium parameters used: Medium parameters used:  $f = 415.4$  MHz;  $\sigma = 0.845$  mho/m;  $\epsilon_r = 45.211$ ;  $\rho = 1000$  kg/m<sup>3</sup>, Medium parameters used:  $f = 432.2$  MHz;  $\sigma = 0.86$  mho/m;  $\epsilon_r = 44.793$ ;  $\rho = 1000$  kg/m<sup>3</sup>, Medium parameters used:  $f = 447.6$  MHz;  $\sigma = 0.874$  mho/m;  $\epsilon_r = 44.435$ ;  $\rho = 1000$  kg/m<sup>3</sup>, Medium parameters used:  $f = 464.4$  MHz;  $\sigma = 0.889$  mho/m;  $\epsilon_r = 44.123$ ;  $\rho = 1000$  kg/m<sup>3</sup>, Medium parameters used:  $f = 479.8$  MHz;  $\sigma = 0.902$  mho/m;  $\epsilon_r = 43.831$ ;  $\rho = 1000$  kg/m<sup>3</sup>  
 - Electronics: DAE3 Sn442; Probe: ET3DV6 - SN1380; ConvF(6.95, 6.95, 6.95)  
 - Phantom: ELI 4.0; Serial: 1101; Phantom section: Flat Section

### Configuration/Channel 1 Test/Area Scan Relative (11x121x1):

Measurement grid: dx=15mm, dy=15mm

Pre-scan: SAR(1 g) = 1.65 mW/g; SAR(10 g) = 0 mW/g

Maximum value of SAR (interpolated) = 1.787 mW/g

### Configuration/Channel 2 Test/Area Scan Relative (11x121x1):

Measurement grid: dx=15mm, dy=15mm

Pre-scan: SAR(1 g) = 2.55 mW/g; SAR(10 g) = 0 mW/g

Maximum value of SAR (interpolated) = 3.770 mW/g

### Configuration/Channel 3 Test/Area Scan Relative (11x121x1):

Measurement grid: dx=15mm, dy=15mm

Pre-scan: SAR(1 g) = 3.37 mW/g; SAR(10 g) = 0 mW/g

Maximum value of SAR (interpolated) = 16.063 mW/g

### Configuration/Channel 4 Test/Area Scan Relative (11x121x1):

Measurement grid: dx=15mm, dy=15mm

Pre-scan: SAR(1 g) = 1.95 mW/g; SAR(10 g) = 0 mW/g

Maximum value of SAR (interpolated) = 2.153 mW/g

### Configuration/Channel 5 Test/Area Scan Relative (11x121x1):

Measurement grid: dx=15mm, dy=15mm

Pre-scan: SAR(1 g) = 1.94 mW/g; SAR(10 g) = 0 mW/g

Maximum value of SAR (interpolated) = 16.064 mW/g

## SAR MEASUREMENT PLOT 8

Ambient Temperature  
Liquid Temperature  
Humidity

20.9 Degrees Celsius  
20.3 Degrees Celsius  
42 %



Test Date: 18 May 2011

File Name: M110447R 450 MHz Face Frontal Whip Antenna 18-05-11.da52:0

DUT: TMC Radio PTT RF SPK/MIC; Type: PAR-9180 LMR4; Serial: Prototype

\* Communication System: Simoco (TMC Radio) PTT; Frequency: 416.025 MHz, Frequency: 432.025 MHz, Frequency: 448.025 MHz, Frequency: 464.025 MHz, Frequency: 479.975 MHz; Duty Cycle: 1:1

\* Medium parameters used: Medium parameters used:  $f = 415.4$  MHz;  $\sigma = 0.845$  mho/m;  $\epsilon_r = 45.211$ ;  $\rho = 1000$  kg/m<sup>3</sup>, Medium parameters used:  $f = 432.2$  MHz;  $\sigma = 0.86$  mho/m;  $\epsilon_r = 44.793$ ;  $\rho = 1000$  kg/m<sup>3</sup>, Medium parameters used:  $f = 447.6$  MHz;  $\sigma = 0.874$  mho/m;  $\epsilon_r = 44.435$ ;  $\rho = 1000$  kg/m<sup>3</sup>, Medium parameters used:  $f = 464.4$  MHz;  $\sigma = 0.889$  mho/m;  $\epsilon_r = 44.123$ ;  $\rho = 1000$  kg/m<sup>3</sup>, Medium parameters used:  $f = 479.8$  MHz;  $\sigma = 0.902$  mho/m;  $\epsilon_r = 43.831$ ;  $\rho = 1000$  kg/m<sup>3</sup>  
 - Electronics: DAE3 Sn442; Probe: ET3DV6 - SN1380; ConvF(6.95, 6.95, 6.95)  
 - Phantom: ELI 4.0; Serial: 1101; Phantom section: Flat Section

### Configuration/Channel 1 Test/Area Scan Relative (11x121x1):

Measurement grid: dx=15mm, dy=15mm

Pre-scan: SAR(1 g) = 2.59 mW/g; SAR(10 g) = 0 mW/g

Maximum value of SAR (interpolated) = 6.011 mW/g

### Configuration/Channel 2 Test/Area Scan Relative (11x121x1):

Measurement grid: dx=15mm, dy=15mm

Pre-scan: SAR(1 g) = 2.77 mW/g; SAR(10 g) = 0 mW/g

Maximum value of SAR (interpolated) = 3.666 mW/g

### Configuration/Channel 3 Test/Area Scan Relative (11x121x1):

Measurement grid: dx=15mm, dy=15mm

Pre-scan: SAR(1 g) = 3.46 mW/g; SAR(10 g) = 0 mW/g

Maximum value of SAR (interpolated) = 3.692 mW/g

### Configuration/Channel 4 Test/Area Scan Relative (11x121x1):

Measurement grid: dx=15mm, dy=15mm

Pre-scan: SAR(1 g) = 3.17 mW/g; SAR(10 g) = 0 mW/g

Maximum value of SAR (interpolated) = 5.154 mW/g

### Configuration/Channel 5 Test/Area Scan Relative (11x121x1):

Measurement grid: dx=15mm, dy=15mm

Pre-scan: SAR(1 g) = 3.04 mW/g; SAR(10 g) = 0 mW/g

Maximum value of SAR (interpolated) = 5.597 mW/g

## SAR MEASUREMENT PLOT 9

Ambient Temperature

20.9 Degrees Celsius

Liquid Temperature

20.3 Degrees Celsius

Humidity

42 %



Test Date: 18 May 2011

File Name: System Check 450 MHz Head 18-05-11.da52:0

DUT: Dipole 450 MHz; Type: D450V3; Serial: 1074

- \* Communication System: CW 450 MHz; Frequency: 450 MHz; Duty Cycle: 1:1
- \* Medium parameters used:  $f = 450.4$  MHz;  $\sigma = 0.878$  mho/m;  $\epsilon_r = 44.371$ ;  $\rho = 1000$  kg/m<sup>3</sup>
- Electronics: DAE3 Sn442; Probe: ET3DV6 - SN1380; ConvF(6.95, 6.95, 6.95)
- Phantom: ELI 4.0; Serial: 1101; Phantom section: Flat Section

**Configuration/Channel 1Test/Area Scan (51x121x1):** Measurement grid:

dx=15mm, dy=15mm

Maximum value of SAR (interpolated) = 2.154 mW/g

**Configuration/Channel 1Test/Zoom Scan (7x7x7)/Cube 0:** Measurement grid:

dx=5mm, dy=5mm, dz=5mm

Reference Value = 50.480 V/m; Power Drift = -0.01 dB

Peak SAR (extrapolated) = 3.284 W/kg

**SAR(1 g) = 2.04 mW/g; SAR(10 g) = 1.35 mW/g**

Maximum value of SAR (measured) = 2.174 mW/g

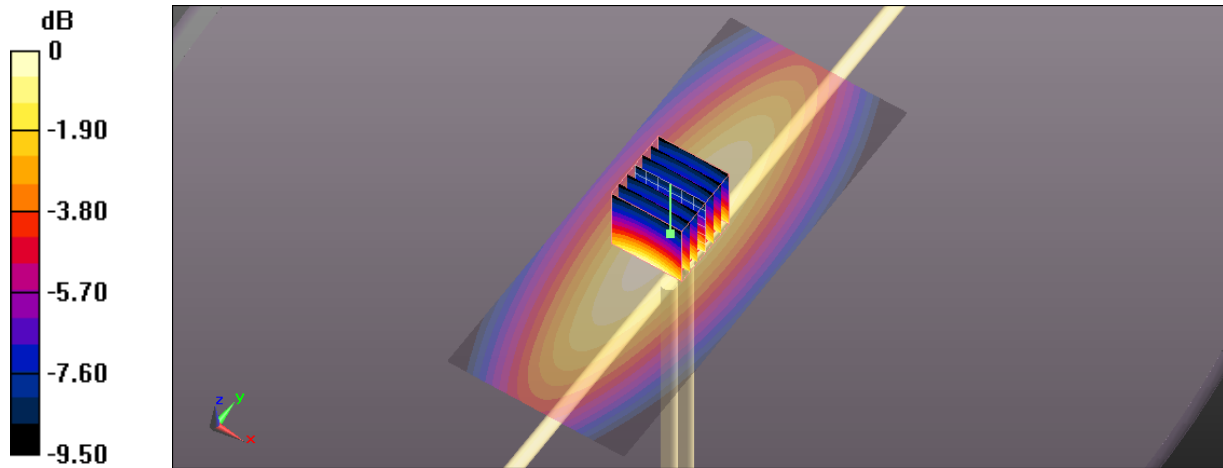

0 dB = 2.170mW/g

**SAR MEASUREMENT PLOT 10**

Ambient Temperature  
Liquid Temperature  
Humidity

20.9 Degrees Celsius  
20.3 Degrees Celsius  
42 %





