

Klipsch

AUTHENTIC  
AMERICAN  
AUDIO



SINCE 1946

Flexus CORE 200

Sound Bar | Barre de son | Barra de sonido | Barra sonora | 条形音箱 | サウンドバー

# KLIPSCH CONNECT APP

---

APPLICATION KLIPSCH CONNECT • APLICACIÓN KLIPSCH CONNECT • KLIPSCH CONNECT APP • APP KLIPSCH CONNECT • APLICATIVO KLIPSCH CONNECT  
KLIPSCH CONNECT应用 • KLIPSCH CONNECTアプリ



1. **Download the Klipsch Connect app**
2. **Follow the instructions**

## ADD TO YOUR SYSTEM

---

Flexus Sound System is built to grow with you. Add up to two wireless subwoofers and wireless surround speakers to create a home theater.

For more information, please visit: <[link to Flexus landing page](#)>

## IMPORTANT SAFETY INSTRUCTIONS

1. Read these instructions
2. Keep these instructions
3. Heed all warnings
4. Follow all instructions
5. Do not use this apparatus near water
6. Clean only with dry cloth.
7. Do not block any ventilation openings. Install in accordance with the manufacture's instructions.
8. Do not install near any heat sources such as radiators, heat registers, stoves, or other apparatus (including amplifiers) that produce heat.
9. Do not defeat the safety purpose of the polarized or grounding plug. A polarized plug has two blades with one wider than the other. A grounding plug has two blades and a third grounding prong. The wide blade or the third prong is provided for your safety. If the provided plug does not fit into your outlet, consult an electrician for replacement of the obsolete outlet.
10. Protect the power cord from being walked on or pinched particularly at the plugs, convenience receptacles, and at the point where they exit from the apparatus.
11. Only use attachments/accessories specified by the manufacturer.
12. Use only with the cart, stand, tripod, bracket, or table specified by the manufacturer, or sold with the apparatus. When a cart or rack is used, use caution when moving the cart/apparatus combination to avoid injury from tip-over.



13. Unplug the apparatus during lightning storms or when unused for long periods of time. Refer all servicing to qualified personnel. Servicing is required when the apparatus has been damaged in any way, such as power supply cord or plug is damaged, liquid has been spilled or objects have fallen into the apparatus has been exposed to rain or moisture, does not operate normally, or has been dropped.

## FCC AND CANADA EMC COMPLIANCE INFORMATION

1. This device complies with Part 15 of the FCC Rules. Operation is subject to the following two conditions:

(1) This device may not cause harmful interference, and (2) This device must accept any interference received, including interference that may cause undesired operation.

2. Any Changes or modifications not expressly approved by the party responsible for compliance could void the user's authority to operate the equipment.

NOTE: This equipment has been tested and found to comply with the limits for a Class B digital device, pursuant to Part 15 of the FCC Rules. These limits are designed to provide reasonable protection against harmful interference in a residential installation. This equipment generates uses and can radiate radio frequency energy and, if not installed and used in accordance with the instructions, may cause harmful interference to radio communications. However, there is no guarantee that interference will not occur in a particular installation. If this equipment does cause harmful interference to radio or television reception, which can be determined by turning the equipment off and on, the user is encouraged to try to correct the interference by one or more of the following measures:

- Reorient or relocate the receiving antenna.
- Increase the separation between the equipment and receiver.
- Connect the equipment into an outlet on a circuit different from that to which the receiver is connected.
- Consult the dealer or an experienced radio/TV technician for help.

#### FCC RF Radiation Exposure Statement

1. This equipment complies with FCC RF radiation exposure limits set forth for an uncontrolled environment.
2. This transmitter must not be colocated or operating in conjunction with any other antenna or transmitter.
3. This equipment complies with FCC radiation exposure limits set forth for an uncontrolled environment. This equipment should be installed and operated with minimum distance 20cm between the radiator & your body.

#### CE RF Radiation Exposure Statement

This device can be operated in at least one Member State without infringing applicable requirements on the use of radio spectrum.

This equipment complies with EU radiation exposure limits set forth for an uncontrolled environment.

This equipment should be installed and operated with minimum distance 20 cm between the radiator and your body.

This device complies with Industry Canada's licence-exempt RSSs. Operation is subject to

the following two conditions:

- (1) This device may not cause interference; and
- (2) This device must accept any interference, including interference that may cause undesired operation of the device

Le présent appareil est conforme aux CNR d'Industrie Canada applicables aux appareils radio exempts de licence. L'exploitation est autorisée aux deux conditions suivantes :

- (1) l'appareil ne doit pas produire de brouillage, et
- (2) l'utilisateur de l'appareil doit accepter tout brouillage radioélectrique subi, même si le brouillage est susceptible d'en compromettre le fonctionnement."

#### Radio Frequency (RF) Exposure Information

The radiated output power of the Wireless Device is below the Industry Canada (IC) radio frequency exposure limits. The Wireless Device should be used in such a manner such that the potential for human contact during normal operation is minimized.

This device has also been evaluated and shown compliant with the IC RF Exposure limits under mobile exposure conditions. (antennas are greater than 20cm from a person's body).

for each off mode, standby mode (or another condition which does not exceed the applicable power consumption requirements for off mode or standby mode) and networked standby into which the equipment is switched by the power management function or similar function:

- the power consumption expressed in watts rounded to the first decimal place;
- the period after which the equipment reaches automatically standby mode, off mode or networked standby in minutes and rounded to the nearest minute;

DC OUT 1 -----USB Type-C(5V/2.0A)

DC OUT 2-----USB Type-A(connect with Flexus Transport 100) ,data transmission

# INSIDE

CONTENU • CONTENIDO • INHALT • CONTENUTO • CONTEÚDO • 内 • 内部



Sound Bar



Wall-Mount Template

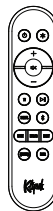

Remote

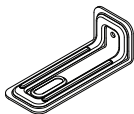

Wall Mount Brackets (2)



Wall Mount Screws (2)

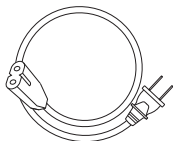

Power Cord

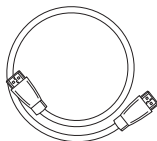

HDMI Cable

## Sound Bar

Barre de son  
Barra de sonido  
Sound Bar  
Sound Bar  
Barra sonora  
条形音箱  
サウンドバー

## Wall-Mount Template

Gabarit de montage mural  
Plantilla de montaje en la pared  
Wandbefestigungsschablone  
Dima per il fissaggio a parete  
Modelo para instalação na parede  
挂壁模板  
壁取付け用テンプレート

## Remote

Télécommande  
Control remoto  
Fernbedienung  
Telecomando  
Controlre remoto  
遥控器  
リモート

## Wall Mount Brackets

Supports pour montage mural  
Soportes de montaje en la pared  
Wandhalterungen  
Staffe per montaggio a parete  
Suportes para montagem em parede  
壁掛式支架  
壁取付け用ブラケット

## Wall Mount Screws

vis pour montage mural  
Tornillos de 1/4 plg.  
1/4" Schrauben  
Viti per montaggio a parete  
Parafusos 1/4"  
1/4" 螺钉  
壁取付け用ねじ

## Power Cord

Cordon d'alimentation  
Cordón de alimentación  
Gleichstromkabel  
Cavo di alimentazione  
Cabo de alimentação  
直流电源线  
電源コード

## HDMI Cable

Câble HDMI  
Cable de HDMI  
HDMI-Kabel  
Cavo HDMI  
Cabo HDMI  
HDMI 电缆  
HDMIケーブル

# SOUND BAR CONTROLS

BARRE DE SON • BARRA DE SONIDO • SOUND BAR • SOUND BAR • BARRA SONORA • 条形音箱 • サウンドバーコントロール

<b>On / Off</b> Sous tensio / Hors tension Encendido / Apagado Ein / Aus Acceso / Spento Ligar / Desligar 开/关 オン/オフ	<b>Source Select (Toggle)</b> Sélección de la source (commutation) Selección de fuente (cíclica) Quellenwahl (Umschalten) Selezione segnale (in sequenza ciclica) Seleção da fonte (Alternar) 電源选择 (切换) ソース選択(トグル)
<b>Volume Down</b> Volume bas Bajada de volumen Leiser Riduzione volume Diminuir o volume 音量减小 音量ダウン	<b>Volume Up</b> Volume haut Subida de volumen Lauter Aumento volume Aumentar o volume 音量増大 音量アップ

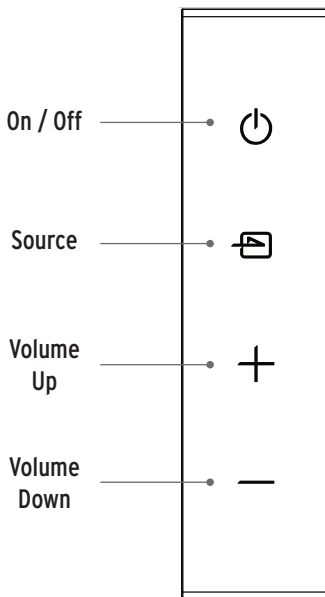

# DIRECT WALL MOUNTING

MONTAGE MURAL DIRECT • MONTAJE DIRECTO EN LA PARED • DIREKTE WANDBEFESTIGUNG • MONTAGGIO DIRETTO A PARETE • MONTAGEM DIRETA NA PAREDE

直接墙上安装 • 壁への直接取付け

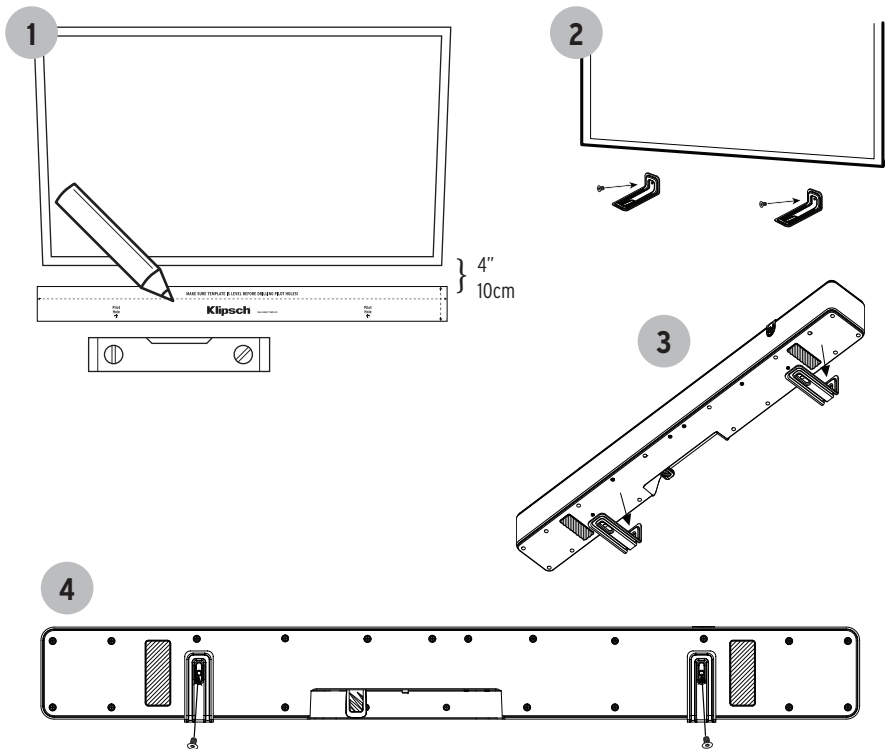



# CONNECTING TO POWER

PUISSANCE DE CONNEXION • CONEXIÓN PODER • VERBINDUNGSSTROM • COLLEGAMENTO ALLA PRESA DI CORRENTE • PODER DE CONEXÃO • 连接电源  
電源に接続する

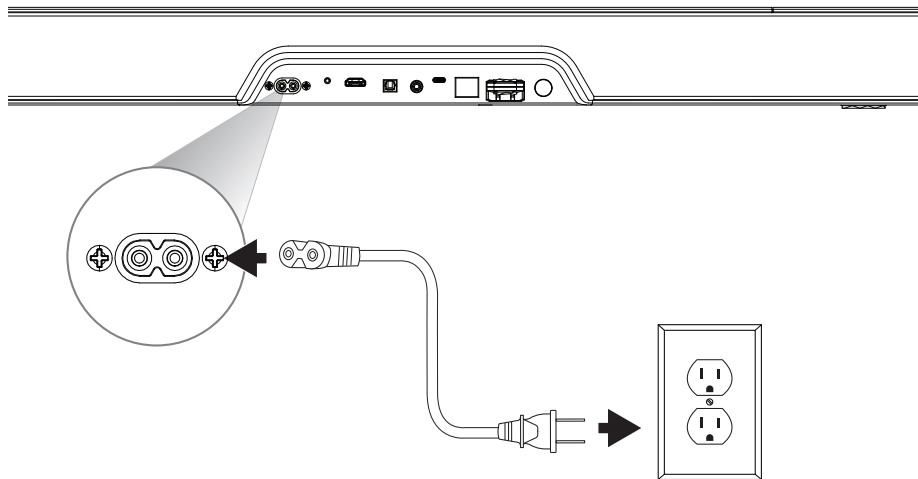

# CONNECTING WIRED SUBWOOFER

CONNEXION CÂBLÉE DU CAISSON DE GRAVES • CONEXIÓN DE SUBWOOFER DE CABLE • KABELANSCHLUSS EINES SUBWOOFERS • COLLEGAMENTO A UN SUBWOOFER CABLATO • CONEXÃO DO SUBWOOFER COM FIO • 连接有线低音炮 • 有線サブウーファアの接続

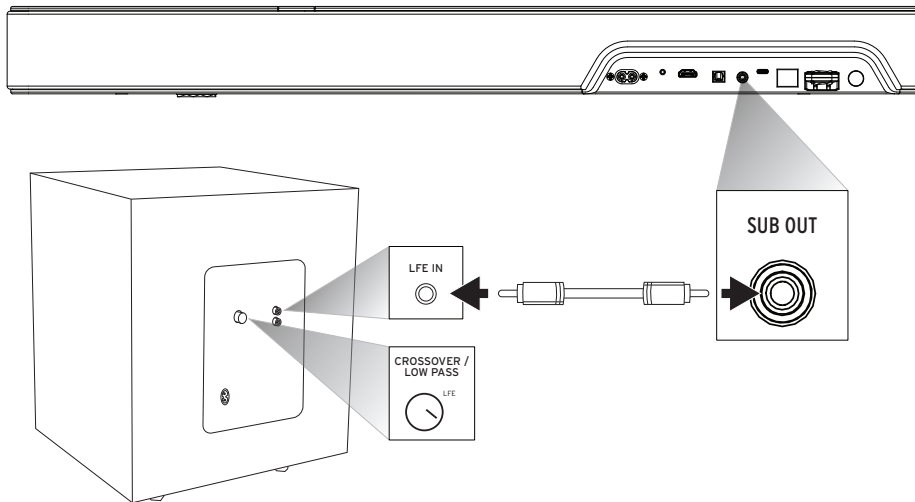

# LED ON/OFF

DEL MARCHE/ARRÊT • ENCENDIDO/APAGADO DE INDICADORES LED • LED AN/AUS • LED ACCESO/SPENTO • LED LIGA/DESLIGA • LED 灯开/关

LED オン/オフ

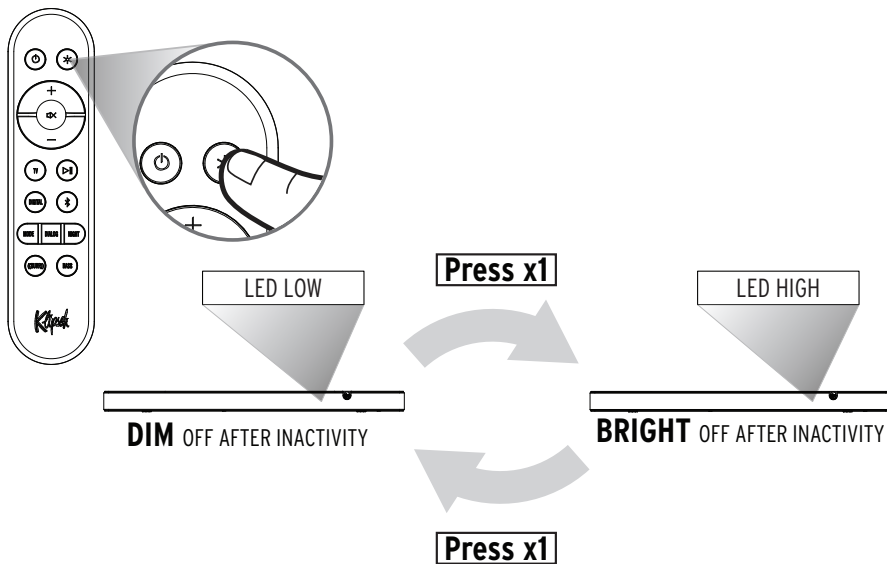







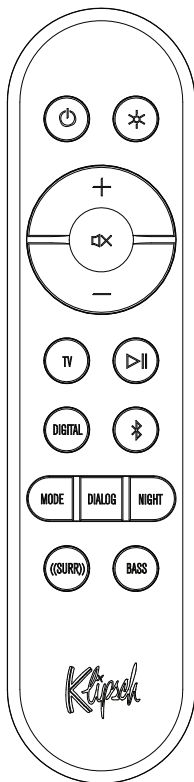



<b>Press x1</b> Appuyer 1 fois Oprima 1 vez 1x drücken Premere 1 volta Pressionar uma vez 按 1 次 X1 を押します	<b>BRIGHT</b> Lumineux Brillante Hell Luminoso Brilhante 明亮 明るい	<b>DIM</b> Sombre Oscuro Dunkel Attenuato Esmaecido 昏暗 暗い	<b>OFF AFTER INACTIVITY</b> Arrêt après inactivité Apagado después de inactividad Nach Inaktivität aus Spento dopo un certo periodo di inattività Apagado depois de inatividade 无操作后关闭 非アクティブ後にオフ
---	--	--	--

# REMOTE

TÉLÉCOMMANDE • CONTROL REMOTO • FERNBEDIENUNG • TELECOMANDO • CONTROL REMOTO • 遥控器







-  **On/Off**
-  **LEDs High/Low**
-  **Source Select**  
Selects HDMI eARC Input
-  **Play/Pause**
-  **Source Select**  
Selects Optical Input
-  **Bluetooth® Source Select**  
Long press to enter Bluetooth pairing mode
-  **Surround Level**  
Adjusts channel levels.  
FH - Front Height  
If surrounds present:  
SL - Side Left Surround  
SR - Side Right Surround
-  **Bass Level**  
Adjusts Bass equalizer value.  
Use [Vol +] and [Vol -] to adjust.

-  **Increase Volume**
-  **Mute**
-  **Decrease Volume**



- 1** **Sound Mode**  
Cycles through available Sound Modes.  
Movie (default) is highly
- 2** **Dialog Boost**  
Toggles through Off, Low, Medium, High
- 3** **Night Mode**  
Enables/disables Night Mode.

## Advanced Functionality

-  **(Long Press):**  
Displays decoding mode.
-  **(Long Press):**  
Sets Dialog Boost to OFF.
-  **(Long Press):**  
Exits Surround adjust mode.
-  **(Long Press):**  
Enters remote pairing mode.
- 
- 

# CONNECTIONS - HDMI eARC

CONNEXIONS - HDMI-ARC • CONEXIONES - HDMI-ARC • ANSCHLÜSSE - HDMI-ARC • CONNESSIONI - HDMI-ARC • CONEXÕES - HDMI-ARC • 连接-HDMI-ARC  
接続 - HDMI-ARC

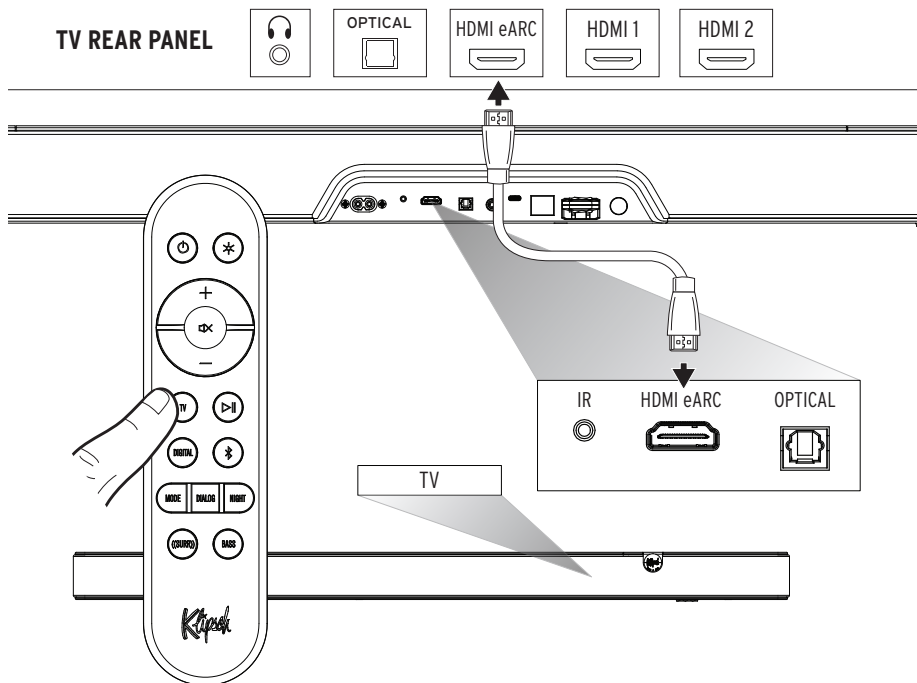

## CONNECTIONS - DIGITAL OPTICAL

CONEXÕES - ÓTICA DIGITAL (SE A TV NÃO TIVER SAÍDA ÓTICA, CONSULTE A PRÓXIMA PÁGINA) • CONEXIONES - DIGITAL ÓPTICA (SI EL TELEVISOR NO TIENE SALIDA ÓPTICA, VEA LA PÁGINA SIGUIENTE.) • ANSCHLÜSSE - DIGITAL-OPTISCH (WENN TV KEINEN OPTISCHEN AUSGANG HAT, SIEHE NÄCHSTE SEITE) • CONNESSIONI - OTTICA DIGITALE (SE IL TELEVISORE NON HA UN'USCITA OTTICA, VEDERE ALLA PAGINA SUCCESSIVA) • CONEXÕES - ÓTICA DIGITAL (SE A TV NÃO TIVER SAÍDA ÓTICA, CONSULTE A PRÓXIMA PÁGINA) • 连接 - 数字光学 (如果电视没有光学输出, 请参见下一页)  
接続 - 光デジタル出力 (TV側に光出力端子がない場合は、次のページを参照)

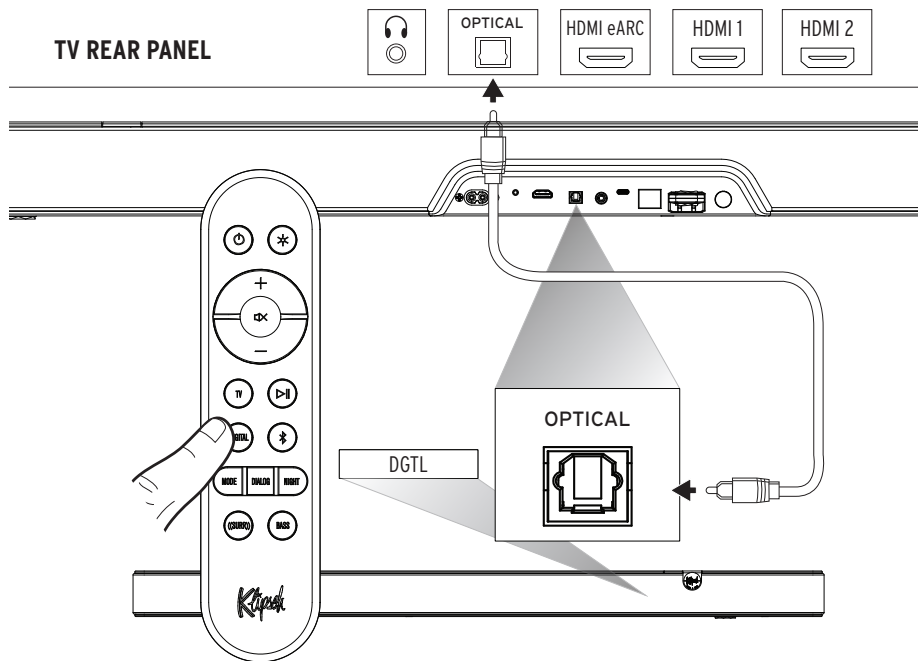

# CONNECTIONS - EXTERNAL HDMI SOURCE THROUGH TV

CONNEXIONS - SOURCE HDMI EXTERNE PAR LA TÉLÉVISION • CONEXIONES - FUENTE EXTERNA DE HDMI A TRAVÉS DE TV • ANSCHLÜSSE - EXTERNE HD-MI-QUELLE VIA FERNSEHER • CONNESSIONI - SORGENTE AUDIO HDMI ESTERNA ATTRAVERSO UN TELEVISORE • CONEXÕES - FONTE HDMI EXTERNA ATRAVÉS DA TV • 连接-通过电视的外部HDMI信号源 • 接続 - TVから外部HDMIソース

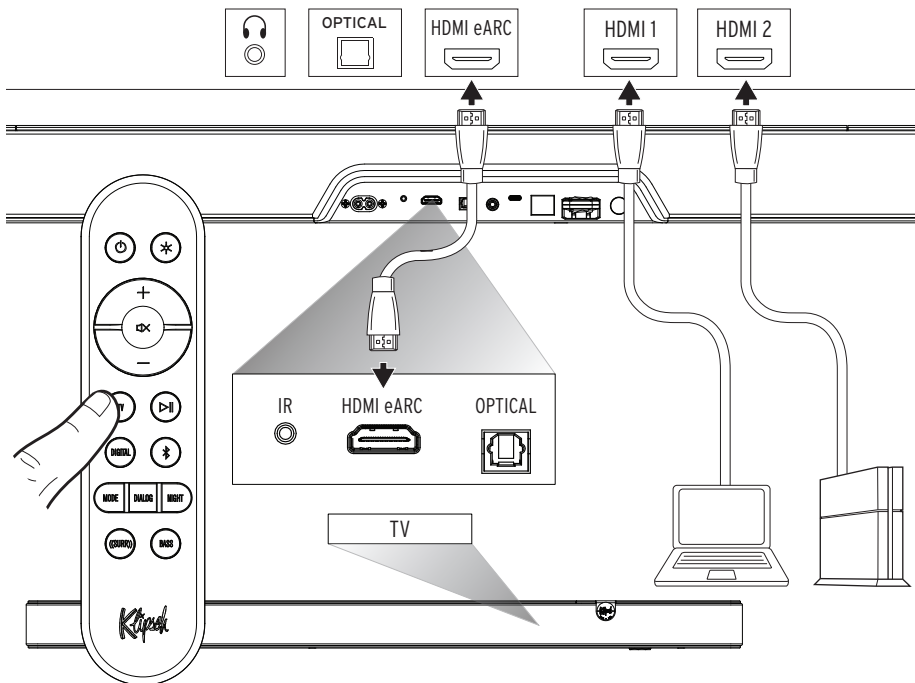

Use this connection method when using external HDMI sources (Streaming boxes, Blu-Ray Players, gaming consoles, etc) to play audio/video content, and want to use TV as the source switch.

Note: This connection method will only support Dolby Atmos playback if your TV supports HDMI eARC. Check your TV owner's manual for compatibility. Dolby Atmos playback also requires Dolby Atmos content and Dolby Atmos compatible playback hardware.

## CONNECTIONS - EXTERNAL AUDIO VIA DIGITAL OPTICAL

CONNEXIONS - AUDIO EXTERNE VIA OPTIQUE NUMÉRIQUE • CONEXIONES - AUDIO EXTERNO POR VÍA DIGITAL ÓPTICA • ANSCHLÜSSE - EXTERNES AUDIO VIA DIGITAL-OPTISCH • CONNESSIONI - AUDIO ESTERNO ATTRAVERSO INGRESSO OTTICO DIGITALE • CONEXÕES - ÁUDIO EXTERNO VIA LIGAÇÃO ÓPTICA DIGITAL • 连接-通过数字光纤的外部音频 • 接続 - 光デジタルケーブルから外部オーディオ

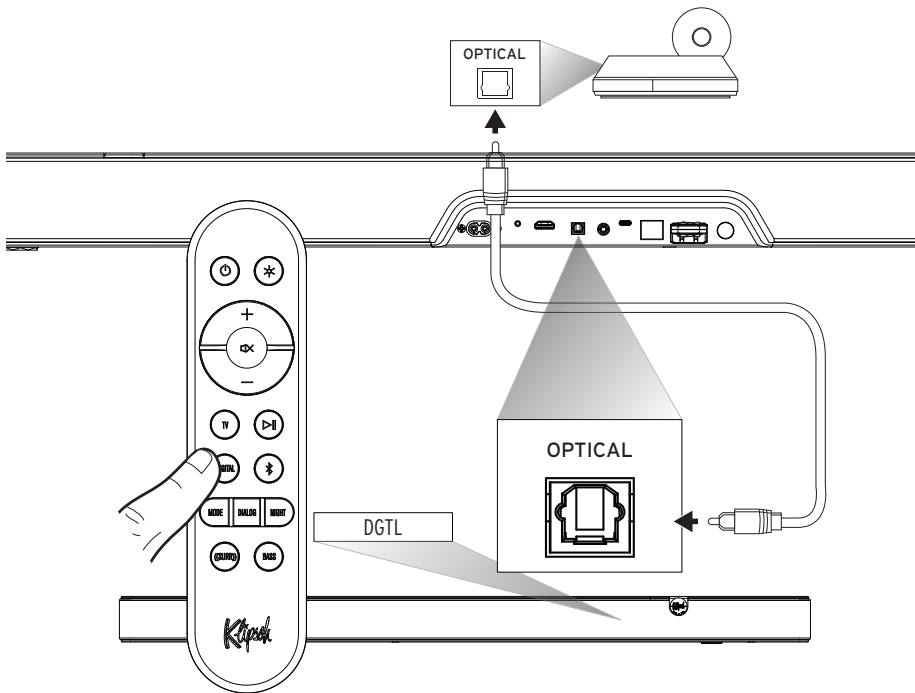

Use this connection method when connecting audio sources with a digital optical output, such as CD Players, PC audio servers, or streaming audio players.

**Note: Digital connection only supports Dolby Audio-Dolby Digital Decoding, not Dolby Atmos.**



# TURN OFF TV SPEAKERS

MISE HORS TENSION DES HAUT-PARLEURS DU TÉLÉVISEUR • APAGADO DE LOS ALTAVOCES DEL TELEVISOR • TV-LAUTSPRECHER DEAKTIVIEREN • SPEGNIMENTO DEGLI ALTOPARLANTI DEL TELEVISORE • DESLIGUE OS ALTO-FALANTES DA TV • 关闭电视机扬声器 • TVスピーカー電源オフ



(Recommended)

OR



OR

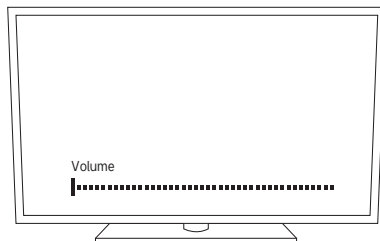

OU RÉGLER SUR AUTO SUR ARC  
O BIEN FIJAR EN "AUTO ON ARC"  
ODER BEI ARC AUF AUTOMATISCH EINSTELLEN  
OPPURE IMPOSTARE SU AUTO ON ARC  
OU CONFIGURE PARA "AUTO ON ARC"  
或设置为 "AUTO ON ARC"  
または「AUTO FOR ARC」に設定する

## ADJUSTING BASS LEVEL

AJUSTEMENT DU NIVEAU DU CAISSON DE GRAVES • AJUSTE DEL VOLUMEN DEL SUBWOOFER • SUBWOOFER-LAUTSTÄRKE EINSTELLEN • REGOLAZIONE DEL LIVELLO DEL SUBWOOFER • AJUSTE DO NÍVEL DO SUBWOOFER • 調整低音炮水平 • サブウーファーレベルの調整

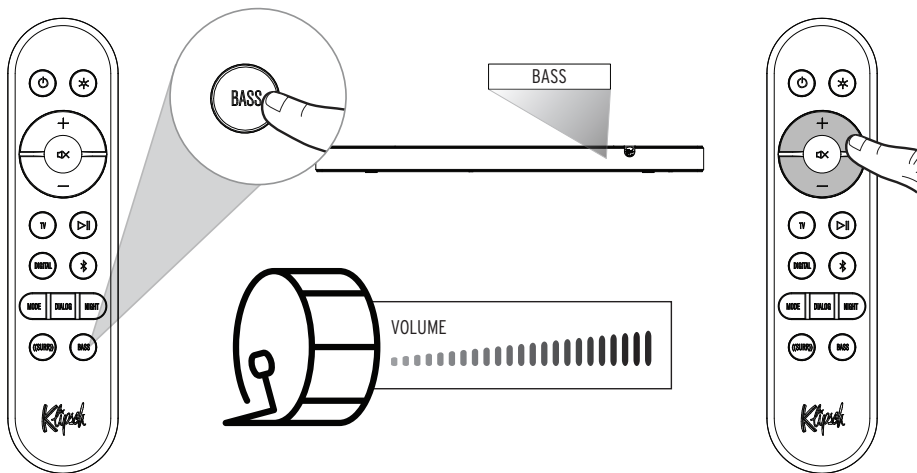

# SURROUND LEVEL ADJUSTMENT

NIVEAU DU SURROUND - AJUSTEMENT RAPIDE • VOLUMEN DE SURROUND - AJUSTE RÁPIDO • SURROUND-LAUTSTÄRKE - SCHNELLEINSTELLUNG • REGOLAZIONE RAPIDA DEL LIVELLO DEL SUBWOOFER • NÍVEL SURROUND - AJUSTE RÁPIDO • 环绕声水平 - 快速调整 • サラウンドレベル - クイック調整

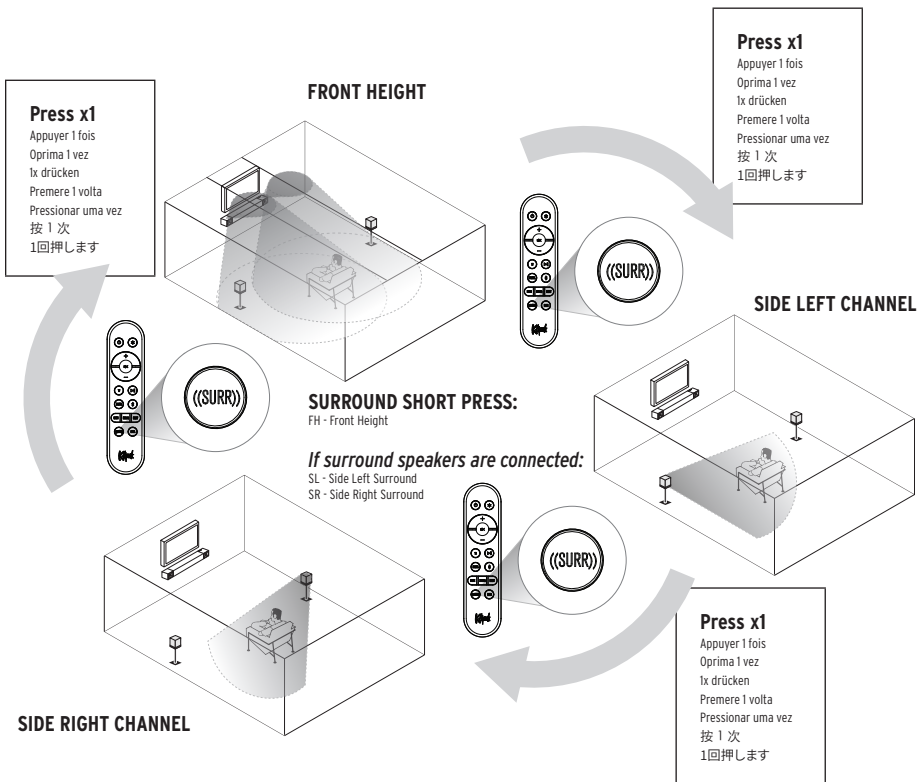

# NIGHT MODE

MODE NUIT • MODALIDAD NOCTURNA • NACHTMODUS • MODALITÀ ORE NOTTURNE • MODO NOTURNO • 夜間模式 • ナイトモード

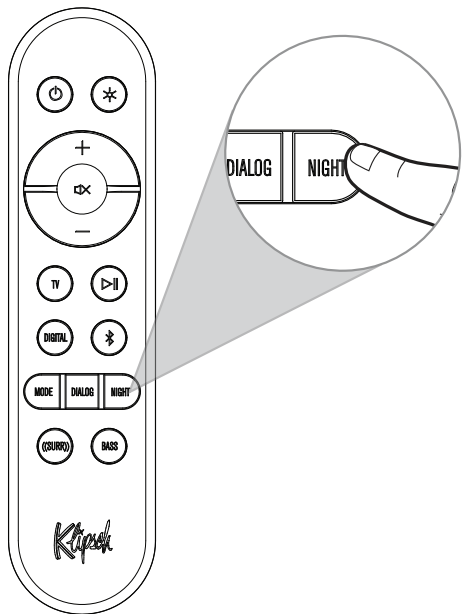

NGT OFF

## NIGHT DISABLED

Full dynamic range with full bass

NIGHT 1x

NGT ON

## NIGHT ENABLED

Reduced dynamic range with compressed bass  
for low volume listening

# DIALOGUE MODE

MODE DIALOGUE • MODALIDAD DE DIÁLOGO • DIALOGMODUS • MODALITÀ DIALOGO • MODO DIÁLOGO • 对话模式 • ダイアログモード

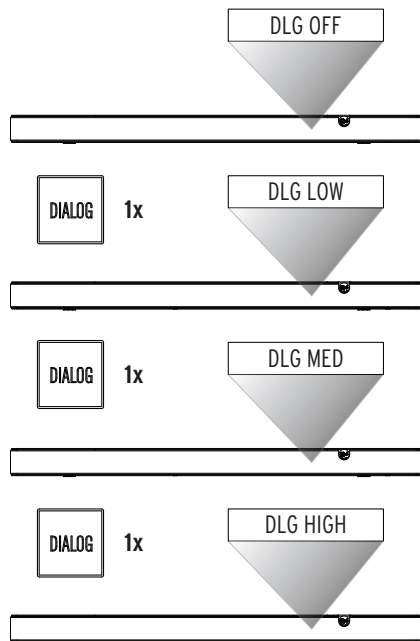
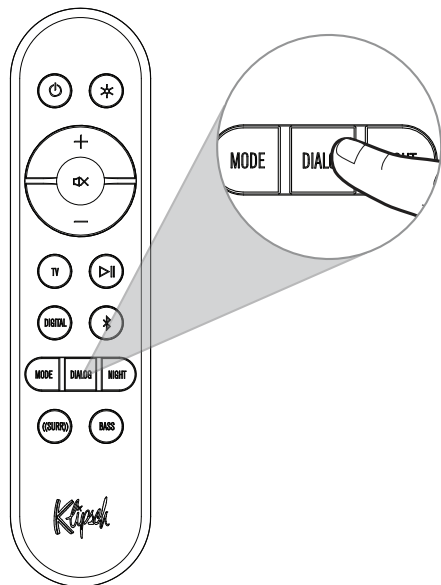

# FACTORY RESET

RÉINITIALISATION • RESTABLECIMIENTO DE FÁBRICA • RÜCKSETZUNG AUF WERKSEINSTELLUNG • RIPRISTINO IMPOSTAZIONI DI FABBRICA  
RESTABELECIMENTO DAS CONFIGURAÇÕES DE FÁBRICA • 恢复出厂设置

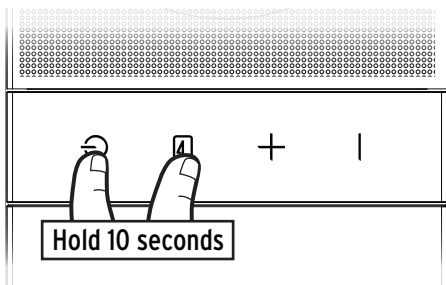

## Hold 10 Seconds

Appuyer pendant 10 secondes  
Mantenga oprimido durante 10 segundos  
10 Sekunden gedrückt halten  
Tenere premuto per 10 secondi  
Manter pressionado por 10 segundos  
保持 10 秒

## Clears *Bluetooth*<sup>®</sup> pairing history and user programmed IR commands

Efface l'historique d'appariement *Bluetooth*<sup>®</sup> et les commandes IR programmées par l'utilisateur

Borra el historial de sincronización de *Bluetooth*<sup>®</sup> y los comandos programados por el usuario

Löscht *Bluetooth*<sup>®</sup>-Kupplungsdaten und benutzerprogrammierte IR-Befehle

Vengono cancellati la cronologia delle associazioni *Bluetooth*<sup>®</sup> e i comandi programmati dall'utente sul telecomando a infrarossi

Limpa o histórico de pareamento *Bluetooth*<sup>®</sup> e os comandos de IR programados pelo usuário

清除蓝牙<sup>®</sup>配对历史记录及用户编程的 IR 指令。

## DECODING AND PLAYBACK MODES

---

<b>INCOMING DIGITAL AUDIO SIGNALS THE FLEXUS CORE 200 WILL DECODE</b>	PCM
	LPCM Up to 8 Channels
	Dolby Audio-Dolby Digital (2.0, 5.1, Etc.)
	Dolby Audio-Dolby Digital Plus (2.0, 5.1, 7.1, Etc.)
	Dolby TrueHD
	Dolby Atmos

Flexus Core 200 comes equipped with several user selectable playback modes. Depending on which playback mode the user has selected, the system will decode the surround sound signal. The following chart shows which playback modes will result in which type of surround sound from the system, along with the recommended uses for each mode.

<b>USER SELECTED INPUT MODE</b>	<b>OUTPUT FORMAT</b>	<b>RECOMMENDED FOR:</b>
<b>MOVIE (DEFAULT)</b>	Dolby Atmos mixed to 5.1.4	The most immersive and complete system tuning for everyday use. Perfect for shows and movies, Movie mode upmixes all signals into all available channels and virtualizes a wide soundstage. Movie mode boosts surround effects and increases dialog clarity.
<b>MUSIC</b>	Dolby Atmos mixed to 5.1.4	Optimized to keep music sounding like the artist intended, Music mode disables virtualization, dialog enhancement, and boosted surround experience while maintaining upmixing stereo sources to all available channels.

# LED DISPLAY

	DISPLAY	BAR STATUS
<b>INPUTS</b>	BT	Bluetooth Input Selected
	DIGITAL	Digital (Optical) input Selected
	TV	HDMI-eARC input Selected
	USB	USB Thumb Drive Input
<b>SOUND MODES</b>	MOVIE (Default)	Movie Mode ON
	MUSIC	Music Mode ON
<b>DIALOG MODE</b>	DLG OFF	Dialog Boost Off
	DLG LOW	Dialog Boost Low
	DLG MED	Dialog Boost Medium
	DLG HIGH	Dialog Boost High
<b>NIGHT MODE</b>	NGT OFF	Night Mode OFF
	NGT ON	Night Mode ON

	DISPLAY	BAR STATUS
<b>LEVEL ADJUST</b>	[SOURCE] XX	System Volume Setting [0] - [50]
	MUTE	System Muted / Volume Set To Minimum
	[SOURCE] MAX	System Volume Set To Max
	BASS [XX]	Bass equalizer volume [-6] - [+6]
<b>CEC TOGGLE</b>	CEC [XXX]	CEC Protocol Turned [On] or [Off]
<b>DECODING</b>	DOLBY SURROUND	Dolby Audio (supporting Dolby Digital, Dolby Digital Plus, Dolby TrueHD)
	DOLBY ATMOS	Dolby Atmos Input
	PCM	PCM or LPCM Input
<b>OTHER</b>	BT PAIRING	Pairing Bluetooth
	BT PAIRED	Bluetooth Paired
	LED HI	LED high brightness
	LED LOW	LED low brightness



# **Klipsch®**

**KEEPERS OF THE SOUND**

**3502 WOODVIEW TRACE, INDIANAPOLIS, IN, USA**

**KLIPSCH.COM**

©2023, Klipsch Group, Inc. Klipsch Group, Inc. is a wholly-owned subsidiary of Voxx International Corporation. Klipsch and Keepers of the Sound are trademarks of Klipsch Group, Inc., registered in the United States and other countries. The *Bluetooth®* word mark is a registered trademark owned by Bluetooth SIG, Inc. and any use of such mark by Klipsch Group, Inc. is under license.

V00 - 23110