



Classic Wooden Turntable with Dust Cover



Instruction Manual/ Bedienungsanleitung/ Manuel d'instructions/
Manual de instrucciones/ 取扱説明書/ Manuale di istruzioni

INTRODUCTION

Thank you for purchasing 1byone Suitcase Turntable. This instruction manual contains important information about safety, usage, and disposal. Use the product as described and keep this manual for future reference. If you sell this turntable or pass it on, also give this manual to the new owner.



The exclamation point within an equilateral triangle is intended to alert users to the presence of important operating and maintenance (servicing) instructions in the literature accompanying the appliance.



The lightning flash with arrowhead symbol within an equilateral triangle is intended to alert users to the presence of uninsulated "dangerous voltage" within the product's enclosure that may be of sufficient magnitude to constitute a risk of electric shock to persons.



This symbol indicates that this product incorporates double insulation between hazardous mains voltage and user accessible parts.

FCC WARNINGS

This device complies with Part 15 of the FCC Rules. Operation is subject to following two conditions:

- (1) this device may not cause harmful interference.
- (2) this device must accept any interference received, including interference that may cause undesired operation.

Warning:

Changes or modifications to this unit is not approved by the party responsible for compliance could void the user's authority to operate the equipment.

NOTE: This equipment has been tested and found to comply with the limits for a Class B digital device, pursuant to Part 15 of the FCC Rules. These limits are designed to provide reasonable protection against harmful interference in a residential installation. This equipment generates, uses, and can radiate radio frequency energy and, if not installed and used in accordance with the instructions, may cause harmful interference to radio communications. However, there is no guarantee that interference will not occur in a particular installation. If this equipment does cause harmful interference to radio or television reception, which can be determined by turning the equipment off and on, the user is encouraged to try to correct the interference by one or more of the following measures:

Notes:

- Reorient or relocate the receiving antenna.
- Increase the separation between the equipment and receiver.
- Connect the equipment into an outlet on a circuit different from that to which the receiver is connected.
- Consult the dealer or an experienced radio/TV technician for help.

Notes:

To maintain compliance with FCC's RF Exposure guidelines, This equipment should be installed and operated with minimum distance between 20cm the radiator your body: Use only the supplied antenna.

BOX CONTENTS

Make sure the items listed below are included in the box:

- ◆ Main Turntable Unit
- ◆ Power Adapter
- ◆ Instruction Manual

PLEASE READ THIS INSTRUCTION MANUAL BEFORE USING THE TURNTABLE

BACK PANEL

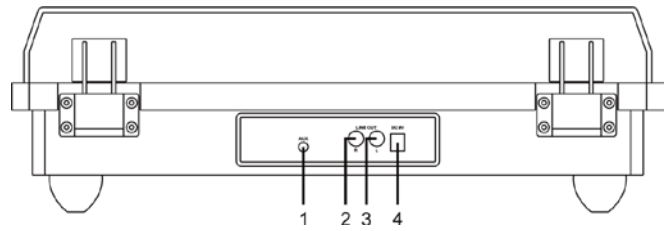

- 1. AUX IN
- 2. LINE OUT R
- 3. LINE OUT L
- 4. DC 9V/2000 mA

FRONT LEFT PANEL

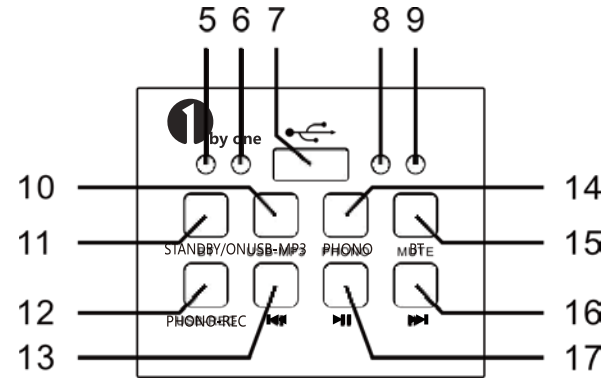

TURNTABLE PANEL

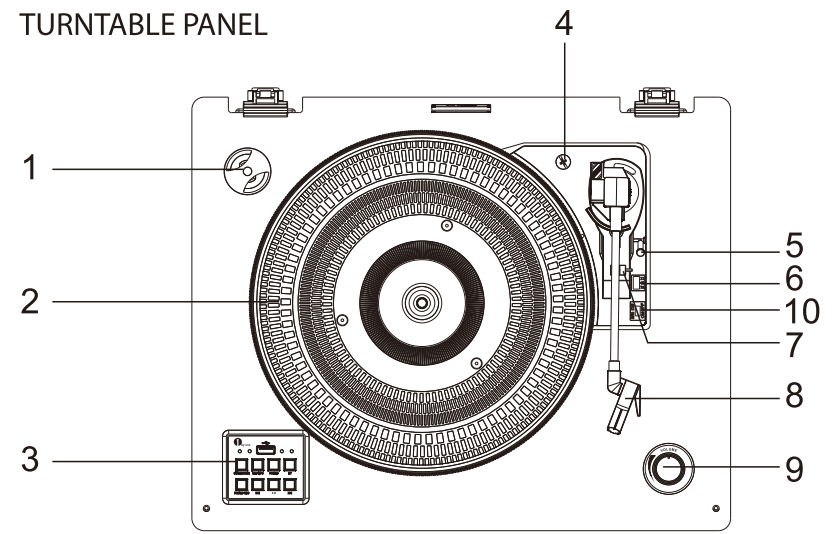

- 1. 45 RPM ADAPTER
- 2. TURNTABLE
- 3. CONTROL PANEL
- 4. TRANSIT SCREW CROSSING
- 5. LIFT LEVER
- 6. SPEED SELECTOR(33/45/78 RPM)
- 7. TONE ARM LOCK
- 8. TONE ARM WITH STYLUS
- 9. VOLUME DIAL
- 10. AUTO STOP CONTROL SWITCH

- 5. STANDBY/ON INDICATOR
- 7. USB SOCKET
- 9. BT INDICATOR
- 11. STANDBY/ON BUTTON
- 13. ⏪ BUTTON
- 15. BT BUTTON
- 17. ⏩ BUTTON

- 6. USB PLAYER INDICATOR
- 8. PHONO PLAYER/REC INDICATOR
- 10. USB-MP3 PLAYER BUTTON
- 12. PHONO-REC BUTTON
- 14. PHONO PLAYER BUTTON
- 16. ⏩ BUTTON

UNPACKING AND SETUP

1. Carefully remove the turntable from the display package and remove all packing material.
2. Unwind the AC adapter power cord and extend it to its full length.
3. Place the turntable on a stable, level surface in proximity to an AC outlet and away from any strong magnetic fields.
4. Plug the power cord into your AC outlet.
5. Remove the opaque white plastic stylus cover from the phonograph stylus by sliding it in the direction of the arrow.
6. Be cautious and gentle when removing this stylus cover, as damage to the stylus is not covered by warranty.
7. Remove the twist-tie securing the tone arm during the shipment.
8. Release the tone arm lever lock.

POWERING ON THE UNIT

1. Connect the AC Adapter to the AC POWER Socket on the back of the turntable.
2. Press the STANDBY/ON button, the STANDBY/ON indicator will turn off and PHONO mode will power on.
3. When you have finished using the turntable, press the STANDBY/ON button again and the voice message "POWER OFF" will confirm the turntable is off.

NOTE

The turntable will automatically turn off without further instruction or signal for 15 minutes.

AUX-IN OPERATION

1. This turntable includes an auxiliary audio signal input jack for connecting external audio devices like MP3 players, CD players, and older, non-dockable iPods so you can listen to your external source through the turntable's speakers.
2. Use an audio cable (not included) with one 3.5 mm stereo connection on each end of the cable.
3. Plug one end into the AUX-IN jack on the turntable and the other end to the Line Out jack of the audio device.
4. Power on the turntable and audio device.
5. The volume level can be controlled through the turntable. Operate all the functions on the auxiliary device as usual.
6. Please note that AUX-IN function is a first-priority function. Even if the indicator light for USB-MP3/PHONO/BT is on, these functions won't work while the AUX-IN function is in use. Please unplug the AUX-IN cable before using the USB-MP3/PHONO/BT functions.
7. Remove the twist-tie securing the tone arm during the shipment.
8. Release the tone arm level lock.

NOTE

1. If the Line Out jack of your external device is connected, you only need to adjust the volume control of this system.
2. Make sure the tone arm is securely locked to avoid any damage.
3. Press STANDBY/ON button to turn off the turntable when you are done. Don't forget to turn off the power on your external device as well.

PLAYING RECORDS

This turntable is full-sized, belt-driven, and plays 33, 45, and 78 RPM records.

1. To turn the turntable on, press the STANDBY/ON button to set the volume to a low level.
2. Press the PHONO button to turn on phono mode. Please be sure that you have removed the stylus cover from the stylus and have released the Tone arm lock.
3. Set the turntable speed switch to the appropriate speed of 33, 45 or 78 RPM. Set the record on the turntable. If you are playing 45 RPM singles, place the 45 RPM adapter on the center spindle.
4. Slide the AUTO STOP CONTROL switch to choose the auto stop function.
5. When finish playing the song, put the LIFT LEVER gently backward to yourself, the tone arm gently lifter onto the record. The song will stop playing.
6. At the end of the record, the TONE ARM will stop automatically. Put the LIFT LEVER gently backward to yourself, the TONE ARM gently lifter onto the record.
7. Adjust the VOLUME control to set the volume as desired.
8. Press the STANDBY/ON button to turn off the system when you are done.
9. Please keep the dust cover open when playing a record.

PHONOGRAPH RECORDING OPERATION

1. Place a phono record on the turntable.
2. Plug a USB disk into the USB socket. Press the PHONO-REC button, the blue LED indicator light will flash, meaning the recording has started.
3. Press the PHONO-REC button again when you are finished recording.
4. Press the USB-MP3 button with the blue light and you will hear the recorded music from the USB.

NOTE

1. PHONO-REC is only for phonograph recording.
2. PHONO-REC is for recording music from the phono record to a USB disk device(-FAT32 format only).

USB OPERATION

1. Press the USB-MP3 button to turn on USB mode. The blue indicator light will turn on.
2. Insert the USB device into the USB input on the turntable and the music tracks on the USB device will start playing.
3. Press the ◀◀ or ▶▶ buttons to choose your desired track.
4. Press the ▶|| button to pause or play the track.
5. Press the STANDBY/ON button to turn off the turntable when you are done.

NOTE

1. USB-MP3 playing mode has a memory function. When reinserting the same USB device, the last played track will be resumed.
2. This turntable is equipped with a USB socket that can play MP3/WMA files stored on standard USB flash drives (compatible with USB version 2.0).
3. USB flash drives with more than 32GB memory may not be compatible.
4. Although this product is fully compatible with the USB 2.0 standard format, a small percentage of USB flash drives might not be readable due to those device manufacturers' non-compliance with full (official) USB standards.

REMOVING THE USB DRIVE

Please be sure the stop playback and turn the unit off before removing the USB drive to avoid damage to the USB and the turntable.

BLUETOOTH OPERATION

1. Press the BT button on the front left panel to activate the BLUETOOTH function and the blue LED light will be flashing.
2. Set up the Bluetooth playback device so it searches for other Bluetooth devices.
3. Select the entry '1byone BS008' from the list of found devices on your Bluetooth playback device. If pairing is successful, the LED light will stop flashing and stay on Blue.
4. Play your music through the connected device and enjoy.

NOTE

1. The next time you turn on the device it will automatically connect to the last Bluetooth playback device connected. If your Bluetooth playback does not automatically reconnect to the device, you will need to manually re-establish the connection to your Bluetooth device.
2. If you use a smartphone as your Bluetooth playback device, the audio file will muted when there is an incoming call. Acceptance/termination of the call is carried out via the smartphone. After finishing the call, music playback will resume automatically.

LINE OUT OPERATION

1. A set of Line Out jacks is included to allow audio from BT, USB-MP3, and PHONOGRAPH of this turntable to play on an external device.
2. Insert the audio cable (not included) into the turntable's Line Out socket.
3. Operate the turntable as usual.
4. In order to achieve the best sound, it is advised to set the turntable volume to a minimal level.
5. The turntable's audio will then be played back through the external device.

REPLACING THE STYLUS

It's suggested to replace the stylus after 400 hours of use.

Please follow the steps below to change the stylus:

1. Lift the tone arm off the tone arm lock.
2. At the front end of the tone arm, place the tip of your fingernail between the red stylus holder and the black cartridge housing as shown. Press down down on the red stylus holder until it separates from the cartridge housing.
3. Completely remove the red stylus holder with worn stylus and discard it.
4. Place the new red stylus holder with stylus under the cartridge housing. First, press upward on the back side of the stylus holder, and then press up on the front edge of the stylus holder until it snaps into place on the cartridge housing.

**IMPORTANT!
TRANSPORTING THE SYSTEM**

1. To protect the turntable from damage during transportation, a silver transit screw is located on the upper right of the turntable platform.
2. Before playing, please use a screwdriver to turn the transit screw in a clockwise direction (screw going down) completely to unlock the turntable.
3. To lock the turntable again for transportation, please turn screw in a counter-clockwise direction.

**CARE OF THE WOOD PANEL AND DUST COVER**

1. Care of the turntable is the same as any piece of furniture.
2. When the dust cover is dusty, you may wipe it using a soft, non-abrasive dust cloth.
3. If the wood panel becomes smudged with fingerprints, you may use any good quality commercial dusting and polishing spray cleaner.
4. We recommend spraying the cleaner on a cloth, not directly on the wooden panel.

CARE AND MAINTENANCE

TO REPLACE THE CARTRIDGE FROM THE TONE ARM PLEASE FOLLOW THE PROCEDURE BELOW.

1. Gently lift off the tone arm from the tone arm lock.
2. Use your left hand to hold the tone arm and your right hand to hold the rear portion of the cartridge. Then push the cartridge backwards and downwards according to the direction as shown to separate the cartridge from the tone arm.
3. Using either a tweezer or your fingers, carefully unplug the terminals to the new cartridge.
4. Carefully connect the terminals to the new cartridge (not included).
5. To re-install the new cartridge to the tone arm, first lock the front end of the new cartridge on the hook of the tone arm.
6. Press the rear side of the new cartridge upwards to lock it on the tone arm.

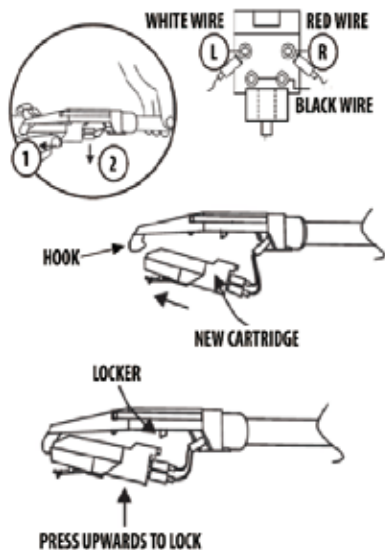

CAUTION:
Please do not damage the stylus when installing the new cartridge.

SPECIFICATIONS

Operating voltage	DC9V/2000 mA
Bluetooth specification	Version 2.1+EDR
Supported storage	USB
Output power	2 x 4W RMS
Dimensions (L*W*H)	434 * 360 * 135.5 mm
Unit weight	4.38 kg

Specifications and functions connected to the continual improvement of the device are subject to change without notice.

Disposal

Disposal of the appliance



Under no circumstances should you dispose of the appliance in the normal domestic waste. This product is subject to the provisions of European Directive 2012/19/EU.

Dispose of the appliance via an approved disposal company or your municipal waste facility. Please observe the currently applicable regulations. Please contact your waste disposal centre if you are in any doubt.



The packaging is made from environmentally friendly material and can be disposed of at your local recycling plant.