

Bluetooth CD Radio Microsystem

Model: SRCD1081BT



Instruction Manual

PLEASE READ THIS INSTRUCTION MANUAL CAREFULLY BEFORE USE
AND KEEP IT FOR FUTURE REFERENCE.

CONTENT

Important Safety Instructions	1
Buttons and Controls	3
Remote Control	4
Getting Started	5
Connecting External Speakers	5
Preliminary	5
Listening to the Radio	5
Adjusting the Volume	6
Listening to a CD	7
Disc Maintenance	8
Aux-In Operation	9
Bluetooth Operation	9
Using the Remote Control	9
Troubleshooting Guide	11
Specifications	12

IMPORTANT SAFETY INSTRUCTIONS

1. Read these instructions – All the safety and operating instructions should be read before this product is operated.
 2. Keep these instructions – The safety and operating instructions should be retained for future reference.
 3. Heed all warnings – All warnings on the appliance and in the operating instructions should be adhered to.
 4. Follow all instructions – All operating and use instructions should be followed.
 5. Do not use this apparatus near water – The appliance should not be used near water or moisture – for example, in a wet basement or near a swimming pool, and the like.
 6. Clean only with a dry cloth.
 7. Do not block any ventilation openings. Install in accordance with the manufacturer's instructions.
 8. Do not install near any heat sources such as radiators, heat registers, stoves, or other apparatus (including amplifiers) that produce heat.
 9. Do not defeat the safety purpose of the polarized or grounding plug. A polarized plug has two blades with one wider than the other. A grounding plug has two blades and a third grounding prong. The wide blade or the third prong is provided for your safety. If the provided plug does not fit into your outlet, consult an electrician for replacement of the obsolete outlet.
 10. Protect the power cord from being walked on or pinched particularly at the plugs, convenience receptacles, and at the point where they exit from the apparatus.
 11. Only use attachments/accessories specified by the manufacturer.
 12. Use only with the cart, stand, tripod, bracket, or table specified by the manufacturer, or sold with the apparatus. When a cart or rack is used, use caution when moving the cart/apparatus combination to avoid injury from tip-over.
- 
13. Unplug the apparatus during lightning storms or when unused for long periods of time.
 14. Refer all servicing to qualified personnel. Servicing is required when the apparatus has been damaged in any way, such as power supply cord or plug is damaged, liquid has been spilled or objects have fallen into the apparatus, the apparatus has been exposed to rain or moisture, does not operate normally, or has been dropped.
 15. Please keep the unit in a well ventilated environment.
 16. Only use attachments/accessories specified or provided by the manufacturer
 17. To reduce the risk of fire or electric shock, do not expose this apparatus to rain or moisture. The apparatus shall not be exposed to dripping or splashing and no objects filled with liquids, such as vases, shall not be placed on apparatus.
 18. CAUTION: Danger of explosion if battery is incorrectly replaced. Replace only with the same or equivalent type. Danger d'explosion si la batterie est remplacée de façon incorrecte. Remplacez-la uniquement avec le même type ou équivalent

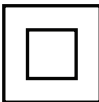
19. The battery (battery or batteries or battery pack) shall not be exposed to excessive heat such as sunshine, fire or the like.
20. The mains plug is used as disconnect device, the disconnect device shall remain readily operable.
21.  This equipment is a Class II or double insulated electrical appliance. It has been designed in such a way that it does not require a safety connection to electrical earth.

22.

 <p>The lightning flash with arrowhead within an equilateral triangle is intended to alert the user to the presence of uninsulated "dangerous voltage" within the product's enclosure that may be of sufficient magnitude to constitute a risk of electric shock.</p>	<p>CAUTION</p> <p>RISK OF ELECTRIC SHOCK DO NOT OPEN</p> <p>CAUTION: TO PREVENT RISK OF ELECTRIC SHOCK, DO NOT REMOVE COVER (OR BACK). NO USER-SERVICEABLE PARTS INSIDE. REFER SERVICING TO QUALIFIED SERVICE PROFESSIONAL.</p>	 <p>The exclamation point within an equilateral triangle is intended to alert the user to the presence of important operating and maintenance (servicing) instructions in the literature accompanying the appliance.</p>
--	--	---

23.  **WARNING**
DO NOT INGEST BATTERY, CHEMICAL BURN HAZARD
 This product contains a coin/button cell battery. If the coin/button cell battery is swallowed, it can cause severe internal burns in just 2 hours and can lead to death.
 Keep new and used batteries away from children. If the battery compartment does not close securely, stop using the product and keep it away from children.
If you think batteries might have been swallowed or placed inside any part of the body, seek immediate medical attention.

COMPLIANCE WITH FCC REGULATION

This device complies with Part 15 of the FCC Rules. Operation is subject to the following two conditions: this device may not cause harmful interference, and

this device must accept any interference received, including interference that may cause undesired operation.

Note: This equipment has been tested and found to comply with the limits for a Class B digital device, pursuant to Part 15 of the FCC Rules. These limits are designed to provide reasonable protection against harmful interference in a residential installation. This equipment generates, uses and can radiate radio frequency energy and, if not installed and used in accordance with the instructions, may cause harmful interference to radio communications. However, there is no guarantee that interference will not occur in a particular installation. If this equipment does cause harmful interference to radio or television reception, which can be determined by turning the equipment off and on, the user is encouraged to try to correct the interference by one or more of the following measures:

- Reorient or relocate the receiving antenna.
- Increase the separation between the equipment and receiver.
- Connect the equipment into an outlet on a circuit different from that to which the receiver is connected.
- Consult the dealer or an experienced radio/TV technician for help.

To maintain compliance with FCC's RF Exposure guidelines. This equipment should be installed and operated with minimum distance between 20cm the radiator your body. Use only the supplied antenna.

WARNING

Changes or modifications not expressly approved by the party responsible for compliance could void the user's authority to operate the equipment.

BUTTONS AND CONTROLS

MAIN UNIT

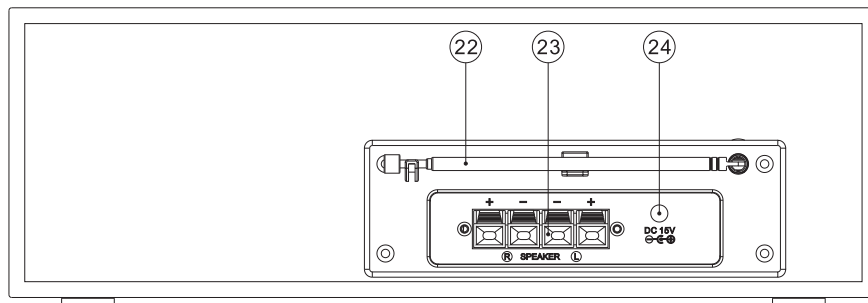
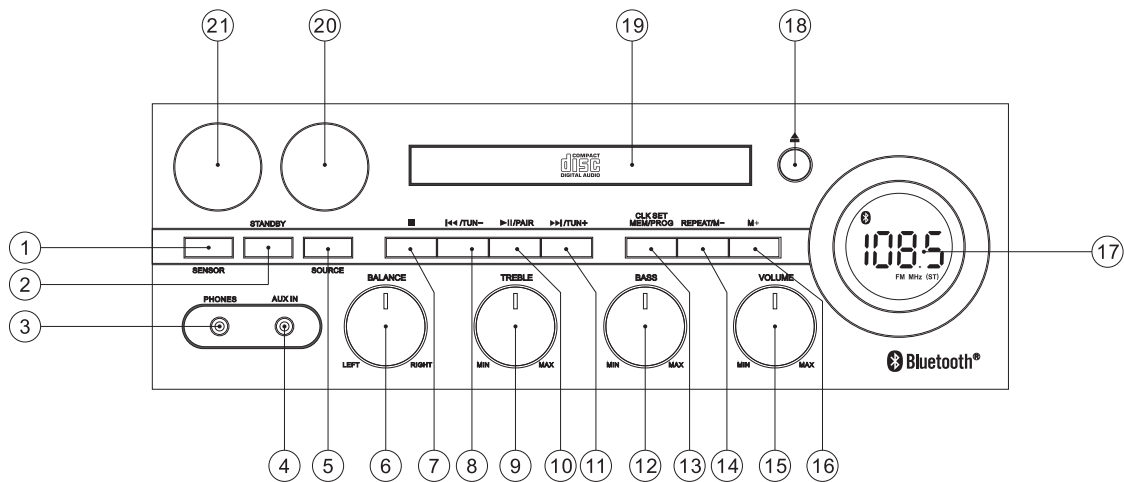

- | | |
|----------------------|------------------------------|
| 1. IR | 12. BASS KNOB |
| 2. STANDBY | 13. CLK SET, MEM/PROG BUTTON |
| 3. PHONES JACK | 14. REPEAT / M- BUTTON |
| 4. AUX IN JACK | 15. VOLUME KNOB |
| 5. SOURCE BUTTON | 16. M+ BUTTON |
| 6. BALANCE KNOB | 17. LCD DISPLAY |
| 7. ■ STOP BUTTON | 18. EJECT/ENTER BUTTON |
| 8. ◀◀ / TUN- BUTTON | 19. CD COMPARTMENT |
| 9. TREBLE KNOB | 20 & 21. VOLUME (VU) METER |
| 10. ▶▶ / PAIR BUTTON | 22. FM ANTENNA |
| 11. ▶▶ / TUN+ BUTTON | 23. SPEAKER SOCKET |
| | 24. DC JACK |

REMOTE CONTROL

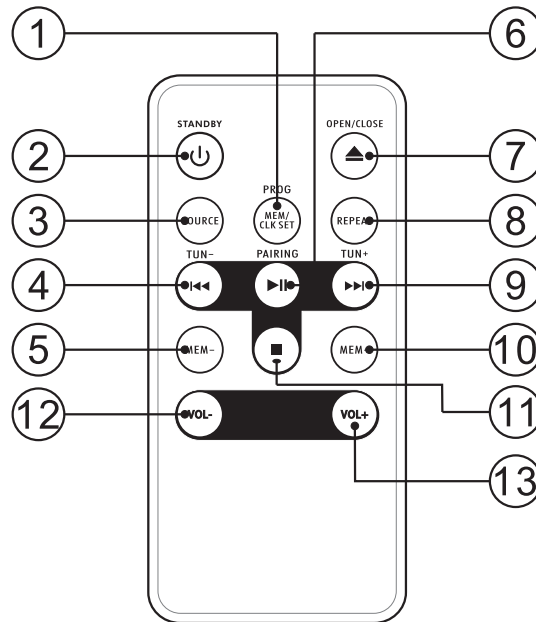

1. **CLOCK SET, MEM/PROGRAM:** Set clock timer, CD program playback and radio memory.
2. **STANDBY BUTTON:** Set the unit to ON / STANDBY.
3. **SOURCE:** Select BLUETOOTH, CD, FM or AUX function.
- 4 & 9. **◀◀ / TUN- , ▶▶ / TUN+:** Skip tracks backward or forward in CD mode. Adjusts the frequency in FM mode.
- 5 & 10. **MEM-/+:** Choose the preset location for the corresponding station.
6. **▶|| / PAIRING :** Pause and resume playback or pairing Bluetooth device.
7. **EJECT/ENTER:** In CD mode, eject and close CD tray.
8. **REPEAT:** Set playback to repeat.
11. **■ STOP BUTTON:** Stop playback.
- 12 & 13. **VOLUME +/- :** Adjust the volume level.

GETTING STARTED

CONNECTING THE EXTERNAL SPEAKERS

The speaker input sockets are located at the back of the main unit.

1. Unwrap the speaker wire from the left speaker and plug it into the left (L) speaker socket on the main unit.
2. Unwrap the speaker wire from the right speaker and plug it into the right (R) speaker socket on the main unit.
3. Make sure the speaker cables are not run in areas where they could cause danger.

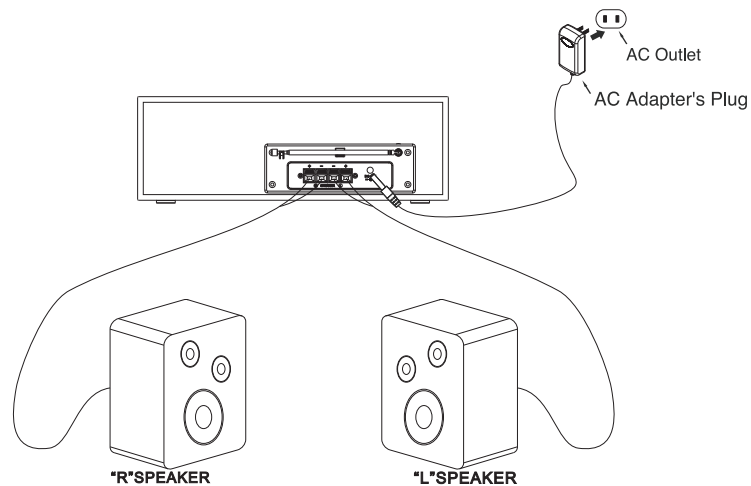

Connecting to a Power Source

1. Check that the mains voltage on the rating plate on the back of the main unit is the same as the voltage in your area.
2. Plug the electric plug into the wall socket. The Bluetooth CD Radio Microsystem is now ready for use.

Standby Control

Press the **STANDBY** button to turn the unit **ON**. Press again to turn the unit **OFF**.

NOTE: When leaving the unit unattended for long periods (such as vacations), please disconnect the power plug from the mains supply.

PRELIMINARY

Before using your audio system, the protective packing should be removed from the CD compartment. To remove the protective packing:

1. Press the **EJECT/ENTER** button to the right of the CD door to open the CD door.
2. Remove the protective packing from the CD compartment.
3. Close the CD door by pressing the **EJECT/ENTER** button again.

FM Antenna

Unwrap the FM antenna and extend it fully. You may need to adjust the position of the antenna to get optimum reception.

LISTENING TO THE RADIO

1. Press the **SOURCE** button to switch to the **FM RADIO**. The display will show a radio station: “**87.5**”.
2. Tune to a desired radio station. The frequency is indicated on the display.
 - **MANUAL TUNING:** Press the **TUN+** or **TUN-** button briefly and the frequency will tune up or down.
 - **AUTO SEARCHING:** Press the **TUN+** or **TUN-** button for more than 2 seconds, the radio frequency will start to change on the display. Once a station is found, the radio will stop searching and start to broadcast immediately.
3. Re-position the antenna if necessary.

SETTING FM RADIO PRESETS

The Bluetooth CD Radio Microsystem can store up to 20 radio station presets. **To Manually Set Presets**

1. Find the radio station you would like to save.
2. Press the **MEM/PROG** button on the main unit or **PROG** button on the remote control.
3. Press **◀ / TUN-** or **▶ / TUN+** buttons to select the preferred Preset Number, The display will show “**P01, P02, etc...**”
4. Press the **MEM/PROG** button on the main unit or remote control again to save the station.
5. Repeat steps 1-4 until you have finished saving your presets.
6. To navigate through the stored presets, press the **MEM+** or **MEM-** buttons.

ADJUSTING THE VOLUME

VOLUME ADJUSTMENT

Twist the **VOLUME KNOB** to adjust the volume. The volume level will be shown in the LCD Display in the top right corner of the unit.

NOTE: Depending on the type of music/audio output from the Bluetooth CD Radio Microsystem, the 2 Volume (VU) Meters might not move at lower volumes. In some cases, the volume must be around “#20 or higher” to see very active movement.

BALANCE

Twist the **BALANCE KNOB** to adjust the volume between the left speaker and the right speaker. The volume of the left speaker and right speaker is equal when the **BALANCE** knob clip in middle.

TREBLE AND BASS

Twist the **TREBLE KNOB** and **BASS KNOB** to adjust the treble and bass levels.

LISTENING TO A CD

1. Press **SOURCE** button until the display reads “**CD**”.
2. Press the **EJECT/ENTER** button to open the CD door, put a CD onto the CD tray with the printed label facing up (towards you). To close the CD door, press **EJECT/ENTER** button again.

Note: Remember to remove the CD when you are finished listening.

To Play a CD When Stopped: Press the **▶||/PAIR** button. The disc will play from track 1 and play indicator appears on the display.

To Pause a CD While Playing: Press the **▶||/PAIR** button. The disc will pause and play indicator blink on the display. Press the **▶||/PAIR** button again to resume playback.

To Stop a CD While Playing: Press the **■ STOP** button.

To Change Tracks: Press **◀◀ / TUN-** button or **◀◀ / TUN+** button.

To Search During Playback: Press and hold the **◀◀ / TUN-** button or **▶▶ / TUN+** button until the desired section is located. While searching, sound will be played at a distorted speed. Playback returns to normal when the button is released.

REPEATING PLAYBACK OF A TRACK OR A CD Press the **REPEAT** button on the main unit or remote control to circle the play mode:

- Repeat 1---Press the **REPEAT** button on the main unit or remote control once and the current track will be played continuously
- Repeat All---Press the **REPEAT** button again and ALL tracks on the current disc will be played continuously.
- Normal playback --- Press **REPEAT** button again to resume normal playback.
Note: Pressing the **■ STOP** button will stop playback and the play mode will be cleared.

PROGRAM PLAY

Program play must be set when the CD is stopped. You can program up to 20 tracks in any order.

1. Press **■ STOP** button and then press **MEM / PROG** button on the main unit or remote control.
2. Press **◀◀ / TUN-** button or **▶▶ / TUN+** button to select a track. The display shows the selected track.
3. Press the **MEM / PROG** button on the main unit or remote control to add the track into the program list.
4. Repeat steps 2 and 3 until you complete the programming. You can program up to 20 tracks.

To Start the Program Play: Press **▶||/PAIR** button.

To Pause or Stop a Program Play: Press **▶||/PAIR** or **■ STOP** button.

To Replay a Program: Press **▶||/PAIR** button.

To Review the Content of a Program: Press **■ STOP** button then keep pressing the **MEM / PROG** button to review the programmed tracks.

To Clear the Program: Press **■ STOP** button twice or open and close the CD door.

DISC MAINTENANCE

Depending on the quality of the disc, and the condition of the recording, some CD-R/CD-RW discs may not be playable.

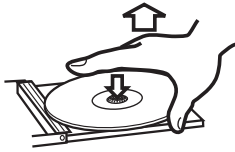

How to remove the disc



How to hold the disc

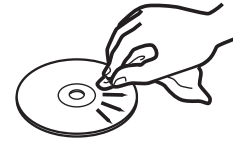

How to clean the disc

1. Always place the compact disc in the disc tray with the label facing upward. (Compact discs can be played only on one side).
2. To move a disc from its storage case, press down on the center of the case and lift the disc out, holding it carefully by the edges.
3. If the disc becomes dirty, wipe the surface from the center hole outward towards the outer edge with a soft, dry cloth.
4. Never use such chemicals as record spray, antistatic sprays or fluid, benzine or thinner to clean the discs. Such chemicals will do irreparable damage to the disc's plastic surface.
5. Discs should be returned to their cases after use to avoid serious scratches that could cause the laser pick up to skip.
6. Do not expose discs to direct sunlight or high humidity and temperature for extended periods. Long exposure to high temperatures will warp the discs.
7. Printable CD-R and CD-RW discs are not recommended, as the label side might be sticky and damage the unit.
8. Use a soft oil-based felt-tipped pen to write the information on the label side. Never use a ball-point or hard-tipped pen, as this may cause damage to the recorded side.
9. Do not use CDs with an irregular shape (octagonal, heart-shaped, business card size, etc). CDs of this sort can damage the unit.

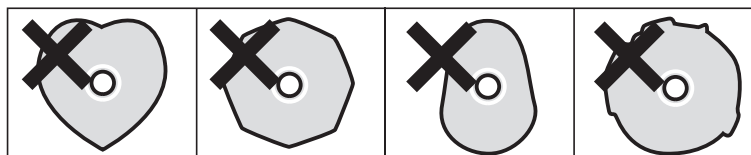

10. If you have any doubts of using CD-R/CD-RW disc, read the precautions supplied with the disc, or contact the disc manufacturer directly.

AUX-IN OPERATION

External (auxiliary) audio sources such as tablets, smartphones or MP3 players, can connect to the Bluetooth CD Radio Microsystem via aux-in.

1. Press **STANDBY** button to turn the unit **ON** and then press **SOURCE** button to select "**AUX**".
2. Set the volume to the minimum level with the **VOLUME KNOB**.
3. Plug in an AUX-IN cable (not included) into the **AUX-IN** jack on the front of the unit.
4. Plug the other end of the cable into the headphone or Line-Out jack of the external source.
5. Turn on the external audio device and set it to play. Turn the external audio device's volume up to 2/3. If necessary, adjust the volume on the main unit by turning the **VOLUME KNOB**.

BLUETOOTH OPERATION

External devices that have a built-in Bluetooth feature can connect wirelessly to the Bluetooth CD Radio Microsystem.

GETTING CONNECTED

1. Press the **SOURCE** button until the Bluetooth indicator shows on LCD Display with blink.
2. Set the Bluetooth function of your external device to **ON** and begin searching for devices.
NOTE: The effective distance between your external device and this apparatus is 10 meters (33 feet).
3. Once "**SRCD1081BT**" appears on the paired devices list of your external device, select it.
4. If you are asked for a password, enter "**0000**".
5. A beep will be heard and Bluetooth indicator light steadily that indicates a connection has been established.
6. A few seconds later your Bluetooth connection should be ready to use.

PLAYING MUSIC FROM AN EXTERNAL BLUETOOTH DEVICE

1. Follow the "GETTING CONNECTED" steps above to pair your external device.
2. Turn on the music player program on your external device and set it to play. Normally, you can control music playback with the **▶||/PAIR**, **◀◀/TUN-** button and **▶▶/TUN+** button on the Bluetooth CD Radio Microsystem.
Note: Some function buttons may not work with all devices.

USING THE REMOTE CONTROL

The Remote Control Unit can operate the unit from a distance. When operating the remote control unit, point it towards the front panel of the unit.

- Even if the remote control unit is operated within the effective range, remote control operation may be impossible if there are any obstacles between the unit and the remote control.

- If the remote control unit is operated near other appliances which generate infrared rays, or if other remote control devices using infrared rays are used near the unit, it may operate incorrectly. Conversely, the other appliances may operate incorrectly.

TO ACTIVATE THE REMOTE CONTROL

The remote control comes with a cell battery already installed. To activate the battery, remove the transparent tab at the bottom of the remote control. The remote control is now ready to use.

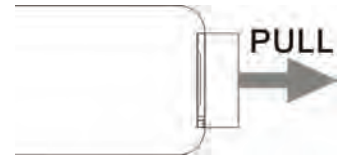

BATTERY REPLACEMENT

If the distance required between the remote control unit and main unit decreases, the battery is exhausted. In this case, please replace the battery with a new one.

To Replace With a New Battery

1. Remove the battery compartment cover as per the illustration on the right.
2. Observe the correct polarity and install a 3Vdc lithium battery (CR2025).
3. Close the cover.

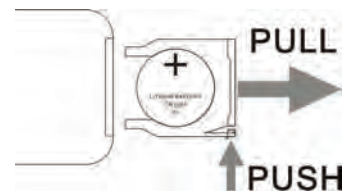

BATTERY PRECAUTIONS

- Be sure to insert the battery with correct positive + and negative - polarities.
- Refer to the precautions on the battery labels.
- When the remote control unit is not to be used for long periods of time (more than a month), remove the battery from the remote control unit to prevent it from leaking. If it leaks, carefully wipe away the liquid inside the battery compartment and replace the battery with a new one.
- Do not heat or disassemble batteries and never dispose of old batteries by throwing them into a fire.

TROUBLESHOOTING GUIDE

In case of trouble with the unit, please look through the problems below and see if you can solve them yourself before calling your dealer.

	PROBLEM	CAUSE	SOLUTION
WHOLE UNIT	Unit does not turn ON when STANDBY is pressed.	<ul style="list-style-type: none"> • Unit is unplugged 	<ul style="list-style-type: none"> • Connect unit to AC power supply
	No sound comes out of the speakers.	<ul style="list-style-type: none"> • The external speakers are disconnected. • The volume is turned down (to MIN). • The input selector does not match the playback source. 	<ul style="list-style-type: none"> • Connect the external speakers. • Adjust the volume. • Re-select the desired input source.
	The sound is noisy.	<ul style="list-style-type: none"> • The unit is too close to a TV set or another similar appliance. 	<ul style="list-style-type: none"> • Turn off the TV or other appliance, and relocate the unit.
	The unit does not act as expected, or respond.	<ul style="list-style-type: none"> • External factors such as ESD (Electro-static discharge) affect the unit. 	<ul style="list-style-type: none"> • Remove the power cord and all power supply devices. Then re-plug the unit after one minute.
RADIO UNIT	Cannot listen to any station, or signal appears weak.	<ul style="list-style-type: none"> • The station is not tuned-in properly. • A TV set is being used nearby and is interfering with the radio reception. 	<ul style="list-style-type: none"> • Properly tune-in the desired station. • Turn-off the interfering TV set.
	The sound is distorted.	<ul style="list-style-type: none"> • The antenna is not positioned properly. 	<ul style="list-style-type: none"> • Re-position the antenna until reception improves.
CD PLAYER	CD stops immediately after starting, or unit pauses or stops during play.	<ul style="list-style-type: none"> • The CD is inserted upside down. • The CD is dusty or dirty or there is condensation on the CD. 	<ul style="list-style-type: none"> • Insert the CD with the printed side right-side up. • Carefully clean and dry the CD.
	No sound.	<ul style="list-style-type: none"> • The CD player is paused. 	<ul style="list-style-type: none"> • Press the PLAY/PAUSE button.
	Specific CD is noisy, or playback stops or skips.	<ul style="list-style-type: none"> • The CD is scratched, damaged or warped. • The disc is very dirty. 	<ul style="list-style-type: none"> • The CD should be changed. • Carefully clean the CD.

SPECIFICATIONS

AMPLIFIER Section

Output Power..... 25W + 25W
Frequency Response 60 to 20,000 Hz

TUNER Section

FM Section
Frequency Range 87.5 to 108 MHz

CD PLAYER Section

Frequency Response 60 to 20,000 Hz
Signal-to-Noise Ratio 55 dB (IEC-A)

SPEAKER SYSTEM Section

Impedance..... 4 ohms
Input Power..... 25W (woofer)
5W / Max 10W (tweeter)

GENERAL

Power Requirements AC 120V ~ 60Hz
Power Consumption..... 60W
Dimensions (L x D x H) 330mm x 222mm x 110mm (approx.)

Loudspeakers Dimensions (L x D x H) 140mm x 155mm x 240mm (approx.)

Weight 5.75kgs (approx.)
Standard Accessories Operating Instruction Booklet;
Remote control with battery;
A pair of external speakers;

Made in China.

NOTE: As a result of continual improvements, the design and specifications of this product are subject to change without notice.

Bluetooth is a registered trademark of Bluetooth SIG, Inc. Other trademarks and trade names are those of their respective owners.

FCC STATEMENT

Warning: Changes or modifications to this unit not expressly approved by the party responsible for compliance could void the user authority to operate the equipment.

NOTE: This equipment has been tested and found to comply with the limits for Class B digital device, pursuant to part 15 of the FCC Rules. These limits are designed to provide reasonable protection against harmful interference in a residential installation. This equipment generates, uses and can radiate radio frequency energy and, if not installed and used in accordance with the instructions, may cause harmful interference to radio or television reception, which can be determined by turning the equipment off and on, the user is encouraged to try to correct the interference by one or more of the following measures:

- Reorient or relocate the receiving antenna.
- Increase the separation between the equipment and the receiver.
- Connect the equipment into an outlet on a circuit different from that to which the receiver is connected.
- Consult the dealer or an experienced radio/TV technician for help.

CALIFORNIA PROP 65 WARNING

"WARNING" This product contains a chemical known to the State of California to cause birth defects or other reproductive harm. For more information on these regulations and a list of chemicals, log on the following website address:
<http://www.oehha.ca.gov/prop65.html>

5000130700E