



Stereo Turntable with Bluetooth and wired speakers

User's Guide for Model ITTB757B v1828-01

For the most up-to-date version of this User's Guide, go to www.iliveelectronics.com

Safety Instructions & Warnings



WARNING: To reduce the risk of electric shock, do not remove cover (or back). No user-serviceable parts inside. Refer servicing to qualified service personnel.



The exclamation point within an equilateral triangle is intended to alert the user to the presence of important operating and maintenance (servicing) instructions in the literature accompanying the appliance.



The lightning flash with arrowhead symbol, within an equilateral triangle, is intended to alert the user to the presence of un-insulated "dangerous voltage" within the product's enclosure that may be of sufficient magnitude to constitute a risk of electric shock to persons.



This symbol indicates that this product incorporates double insulation between hazardous mains voltage and user accessible parts.

Important Safety Instructions

- Read these Instructions.
- Keep these Instructions.
- Heed all Warnings.
- Follow all instructions.
- Do not use this apparatus near water.
- Clean only with a dry cloth.
- Do not block any ventilation openings. Install in accordance with the manufacturer's instructions.
- Do not install near any heat Function switch s such as radiators, heat registers, stoves, or other apparatus (including amplifiers) that produce heat.
- Do not defeat the safety purpose of the polarized or grounding - type plug. A polarized plug has two blades with one wider than the other. A grounding type plug has two blades and a third grounding prong. The wide blade or the third prong are provided for your safety. When the provided plug does not fit into your outlet, consult an electrician for replacement of the obsolete outlet.
- Protect the power cord from being walked on or pinched particularly at plugs, convenience receptacles, and the point where they exit from the apparatus.
- Only use attachments/accessories specified by the manufacturer.
- Unplug this apparatus during lightning storms or when unused for long periods of time.
- Refer all servicing to qualified service personnel. Servicing is required when the apparatus has been damaged in any way, such as power-supply cord or plug is damaged, liquid has been spilled or objects have fallen into the apparatus, the apparatus has been exposed to rain or moisture, does not operate normally, or has been dropped.
- Use only with a cart, stand, tripod, bracket, or table specified by the manufacturer, or sold with the apparatus. When a cart is used, use caution when moving the cart/apparatus combination to avoid injury from tip-over.



FCC Warnings

This device complies with Part 15 of the FCC Rules. Operation is subject to the following two conditions: (1) this device may not cause harmful interference, and (2) this device must accept any interference received, including interference that may cause undesired operation.

Warning: Changes or modifications to this unit not expressly approved by the party responsible for compliance could void the user's authority to operate the equipment.

NOTE: This equipment has been tested and found to comply with the limits for a Class B digital device, pursuant to Part 15 of the FCC Rules. These limits are designed to provide reasonable protection against harmful interference in a residential installation. This equipment generates, uses, and can radiate radio frequency energy and, if not installed and used in accordance with the instructions, may cause harmful interference to radio communications. However, there is no guarantee that interference will not occur in a particular installation. If this equipment does cause harmful interference to radio or television reception, which can be determined by turning the equipment off and on, the user is encouraged to try to correct the interference by one or more of the following measures:

- Reorient or relocate the receiving antenna.
- Increase the separation between the equipment and receiver.
- Connect the equipment into an outlet on a circuit different from that to which the receiver is connected.
- Consult the dealer or an experienced radio/TV technician for help.

Additional Warnings and Precautions

- **CAUTION: TO PREVENT ELECTRIC SHOCK, MATCH WIDE BLADE OF PLUG TO WIDE SLOT, FULLY INSERT.**
- Mains plug is used as disconnect device and it should remain readily operable during intended use. In order to disconnect the apparatus from the mains completely, the mains plug should be disconnected from the mains socket outlet completely.
- **CAUTION:** Use of controls or adjustments or performance of procedures other than those specified may result in hazardous radiation exposure.
- **WARNING:** Changes or modifications to this unit not expressly approved by the party responsible for compliance could void the user's authority to operate the equipment.
- **WARNING:** Use of this unit near fluorescent lighting may cause interference regarding use of the remote. If the unit is displaying erratic behavior move away from any fluorescent lighting, as it may be the cause.
- **WARNING:** Shock hazard - Do Not Open.
- Caution and marking information is located at the rear or bottom of the apparatus.
- **WARNING:** To reduce the risk of fire or electric shock, do not expose this apparatus to rain, moisture, dripping, or splashing.
- Objects filled with liquids, such as vases, shall not be placed on the apparatus.
- **WARNING:** This product may contain chemicals known to the State of California to cause birth defects, or other reproductive harm (California Prop 65). Wash hands after handling.
- This product meets and complies with all Federal regulations.

This equipment complies with FCC radiation exposure limits set forth for an uncontrolled environment. This equipment should be installed and operated with minimum distance 20cm between the radiator & your body.

Table of Contents

Setup	5
Includes	
Power	
Speakers	
Orientation	6
Features & Controls	
Operation	8
Playing a Record	
Pairing Bluetooth and playing Audio Wirelessly	
Using the Aux In (3.5mm Audio Input)	
RCA Audio Output	
Customer Support	10
Contact Information	
Warranty	
International Support	

Setup

Includes

- AC/DC power adapter
- 45 rpm adapter
- Warranty
- User's Guide

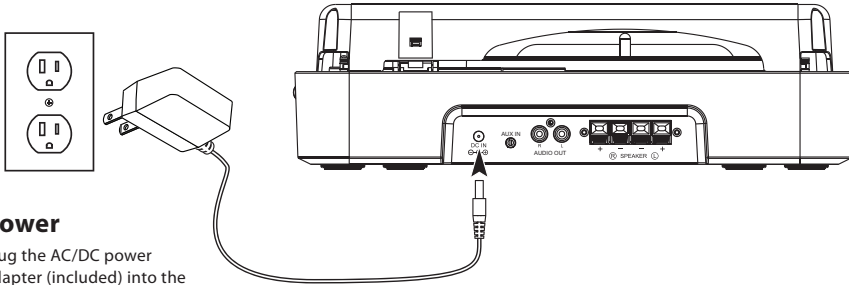

Power

Plug the AC/DC power adapter (included) into the DC power input on the unit and a standard power outlet.

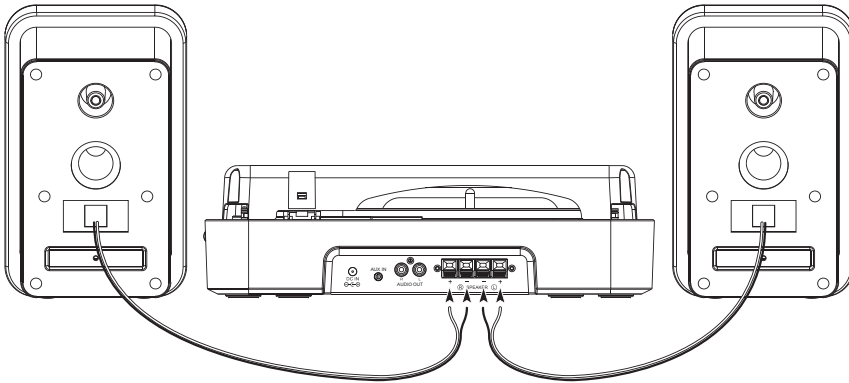

Speakers

Connect the speaker wires to the speaker inputs on the tunnable. Be sure to match the positive (red) and negative (black) wires to their corresponding inputs.

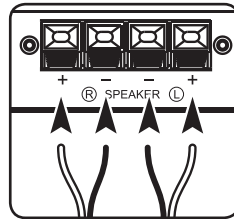

Orientation

Features & Controls

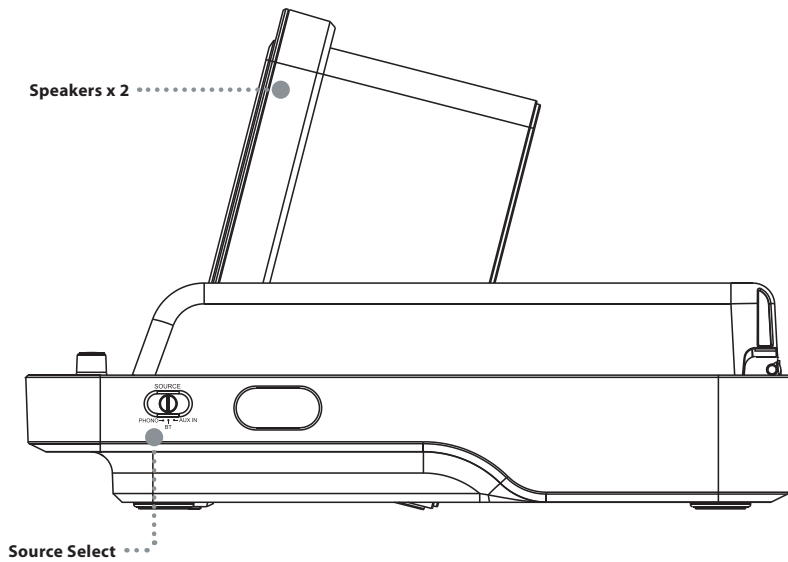
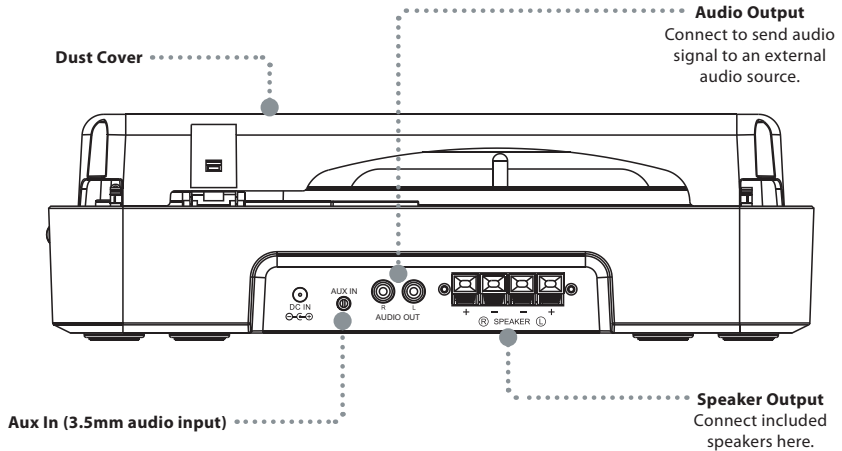

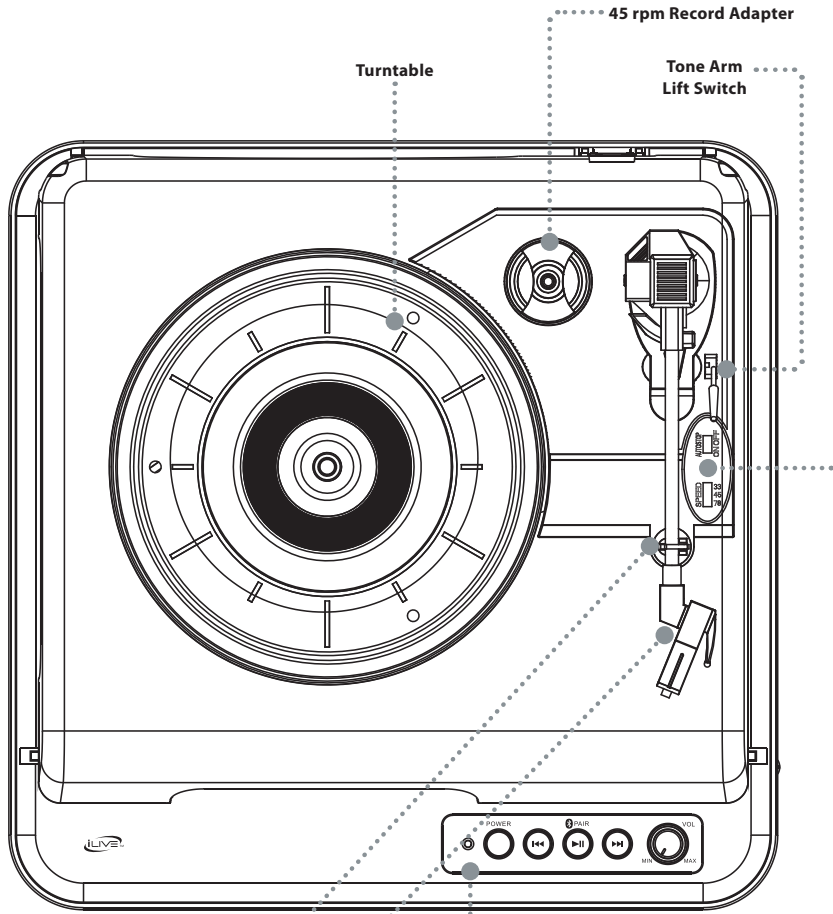

Turntable

45 rpm Record Adapter

Tone Arm
Lift Switch

Tone Arm Lock

Tone Arm & Stylus

Pairing
Indicator

Power
Play/
Pause/Pair

Bluetooth
Stop

Skip Track
Volume

Auto Stop

Select ON or OFF.

Record Speed

Choose 33, 45, or 78, depending on the type of record to be played.

Operation

Playing a Record

It is recommended that you use extreme care when manipulating the tone arm, stylus, and other components of this turntable. These parts are very sensitive and can easily break or become damaged if they are carelessly handled.

1. Set the **Source switch** to **Phono**.
2. Lift open the turntable cover and place the record on the turntable. **If you are playing a 45 rpm record**, use the included 45 rpm adapter and place it between the turntable and the record.
3. Remove the shroud that protects the stylus and release the lock that holds the Tone Arm in place.

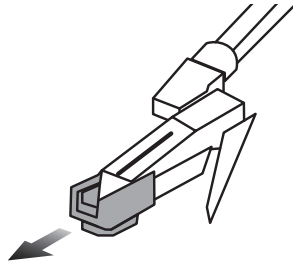

4. Use the **Tone Arm Lift Switch** to raise the **Tone Arm** from its catch.

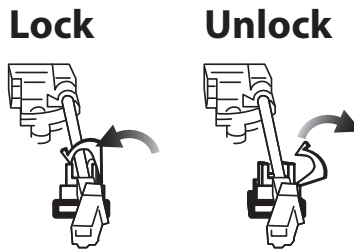

5. Using your hand, *gently* swing the **Tone Arm** into the desired location over the record. The turntable will start spinning as the Tone Arm is moved into position.
6. Use the **Tone Arm Lift Switch** to safely lower the stylus onto the record.
Using the Lift Switch instead of your hand will reduce the chance of accidentally damaging the record or the stylus.
7. Slide the **Auto Stop Switch** to **ON** to enable the Auto Stop feature. When the record is finished playing, it will automatically stop the turntable. Use the **Lift Switch** to raise the stylus off of the record, and *gently* return the Tone Arm to the catch by hand.
Note: Some records place their Auto Stop area outside of the range of this unit. In these cases, the record will stop playing before the last track is reached. Set the Auto Stop Switch to OFF and use the Tone Arm Lift Switch to safely raise the stylus off the record when the end of the record has been reached.
8. When not in use, secure and lock the Tone Arm in its resting position and replace the protective shroud over the stylus. This will minimize the risk of accidental damage to these sensitive parts.

Connecting External Devices

Pairing Bluetooth and playing Audio Wirelessly

1. Set the **Source switch** to **BT** and press and hold the **Play/Pause/Pair** button. The pairing indicator will begin quickly flashing blue. *When pairing, remain within 3 feet of the unit.*
2. Using the controls on your Bluetooth device, search for and select **ITTB757** in your Bluetooth settings to pair. If your device requests a password, enter the default password **0000**. *If need be, refer to the user's manual for your specific device for instructions on pairing and connecting Bluetooth devices.*
3. When successfully paired and connected, an audible chime will sound and the pairing indicator will turn solid. After initial pairing, the unit will stay paired unless unpaired manually by the user or erased due to a reset of the device. If your device should become unpaired or you find it is unable to connect, repeat these steps.
4. Use the controls on your connected Bluetooth Device to select and begin playing audio. Play, pause or skip a selected track using the controls on the connected Bluetooth Device or the controls on the turntable.

Using the Aux In (3.5mm Audio Input)

Requires 3.5 mm audio input cable (not included).

1. Plug a 3.5 mm audio input cable into the **Aux In** on the unit and the headphone jack on an MP3 Player or other audio Function switch .
2. Set the **Source switch** to **Aux** and use the controls on your connected device to select and play audio.
3. Audio played through the connected device should now be heard through the speakers.

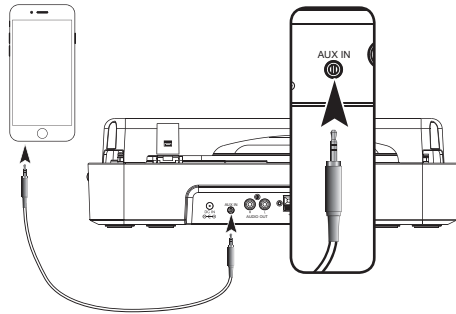

RCA Audio Output

Requires RCA audio cables (red/white, not included). Use to connect the turntable to an external stereo, television, or other Function switch .

1. Connect RCA audio cables to the **Audio Output** on the back of the turntable, and to the **audio input** of an external stereo system. If need be, adjust the external stereo system to accept input from the turntable.
2. Audio played through the turntable should now be heard through the connected stereo system.

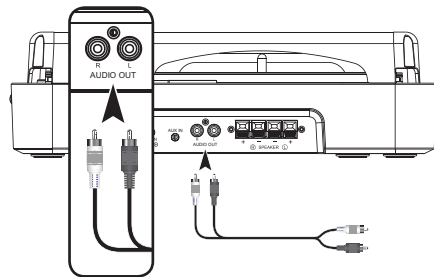

Customer Support

Contact Information

Website: www.iliveelectronics.com

Email Support: prodinfo@dpiinc.com

Email Parts: partsinfo@dpiinc.com

Phone Support: 1-888-999-4215

Warranty

For Warranty Information and the most up-to-date version of this User's Guide, go to: www.iliveelectronics.com

International Support

To download this User's Guide in English, Spanish, and French, or to get answers to frequently asked questions, visit the support section at: www.iliveelectronics.com

Para descargar este Manual del Usuario en inglés, español y francés, o para obtener respuestas a preguntas frecuentes, visite la sección de apoyo en: www.iliveelectronics.com

Pour télécharger ce guide de l'utilisateur en anglais, espagnol ou français, ou pour obtenir des réponses à des questions fréquemment posées, consultez la rubrique d'assistance sur: www.iliveelectronics.com



***Protect for Today
Sustain for Tomorrow***

Copyright © 2016 Digital Products International (DPI, Inc.). All other trademarks appearing herein are the property of their respective owners. Specifications are subject to change without notice.
