



All-in-one Turntable

with Bluetooth, Radio & Stereo Speakers

User's Guide for Model ITTB775B

For the most up-to-date version of this User's Guide, go to www.iLiveElectronics.com

Important Safety Instructions

Important Safety Instructions

- Read these Instructions.
- Keep these Instructions.
- Heed all Warnings.
- Follow all instructions.
- Do not use this apparatus near water.
- Clean only with a dry cloth.
- Do not block any ventilation openings. Install in accordance with the manufacturer's instructions.
- Do not install near any heat sources such as radiators, heat registers, stoves, or other apparatus (including amplifiers) that produce heat.
- Do not defeat the safety purpose of the polarized or grounding - type plug. A polarized plug has two blades with one wider than the other. A grounding type plug has two blades and a third grounding prong. The wide blade or the third prong are provided for your safety. When the provided plug does not fit into your outlet, consult an electrician for replacement of the obsolete outlet.
- Protect the power cord from being walked on or pinched particularly at plugs, convenience receptacles, and the point where they exit from the apparatus.
- Only use attachments/accessories specified by the manufacturer.
- Unplug this apparatus during lightning storms or when unused for long periods of time.
- Refer all servicing to qualified service personnel. Servicing is required when the apparatus has been damaged in any way, such as power-supply cord or plug is damaged, liquid has been spilled or objects have fallen into the apparatus, the apparatus has been exposed to rain or moisture, does not operate normally, or has been dropped.
- Use only with a cart, stand, tripod, bracket, or table specified by the manufacturer, or sold with the apparatus. When a cart is used, use caution when moving the cart/apparatus combination to avoid injury from tip-over.



WARNING: To reduce the risk of electric shock, do not remove cover (or back). No user-serviceable parts inside. Refer servicing to qualified service personnel.



The exclamation point within an equilateral triangle is intended to alert the user to the presence of important operating and maintenance (servicing) instructions in the literature accompanying the appliance.



The lightning flash with arrowhead symbol, within an equilateral triangle, is intended to alert the user to the presence of uninsulated "dangerous voltage" within the product's enclosure that may be of sufficient magnitude to constitute a risk of electric shock to persons.



This symbol indicates that this product incorporates double insulation between hazardous mains voltage and user accessible parts.

Warnings and Precautions

FCC Warnings

Warning: Changes or modifications to this unit not expressly approved by the party responsible for compliance could void the user's authority to operate the equipment.

NOTE: This equipment has been tested and found to comply with the limits for a Class B digital device, pursuant to Part 15 of the FCC Rules. These limits are designed to provide reasonable protection against harmful interference in a residential installation. This equipment generates, uses, and can radiate radio frequency energy and, if not installed and used in accordance with the instructions, may cause harmful interference to radio communications. However, there is no guarantee that interference will not occur in a particular installation. If this equipment does cause harmful interference to radio or television reception, which can be determined by turning the equipment off and on, the user is encouraged to try to correct the interference by one or more of the following measures:

- Reorient or relocate the receiving antenna.
- Increase the separation between the equipment and receiver.
- Connect the equipment into an outlet on a circuit different from that to which the receiver is connected.
- Consult the dealer or an experienced radio/TV technician for help.

Additional Warnings and Precautions

- **CAUTION:** TO PREVENT ELECTRIC SHOCK, MATCH WIDE BLADE OF PLUG TO WIDE SLOT, FULLY INSERT.
- **WARNING:** To reduce the risk of fire or electric shock, do not expose this apparatus to rain, moisture, dripping, or splashing. *AVIS: Pour réduire le risque d'incendie ou de choc électrique, ne pas exposer cet appareil sous la pluie et l'humidité.*
- **CAUTION:** Use of controls or adjustments or performance of procedures other than those specified may result in hazardous radiation exposure.
- **WARNING:** Changes or modifications to this unit not expressly approved by the party responsible for compliance could void the user's authority to operate the equipment.
- **WARNING:** Do not place this unit directly onto furniture surfaces with any type of soft, porous, or sensitive finish. As with any rubber compound made with oils, the feet could cause marks or staining where the feet reside. We recommend using a protective barrier such as a cloth or a piece of glass between the unit and the surface to reduce the risk of damage and/or staining.
- **WARNING:** Use of this unit near fluorescent lighting may cause interference regarding use of the remote. If the unit is displaying erratic behavior move away from any fluorescent lighting, as it may be the cause.
- **CAUTION:** Danger of explosion if battery is incorrectly replaced. Replace only with the same or equivalent type. *AVIS: Danger d'explosion si les piles sont remplacées de façon incorrect. Remplacer les piles seulement par le même type de pile ou équivalent.*
- **WARNING:** There is a danger of explosion if you attempt to charge standard Alkaline batteries in the unit. Only use rechargeable NiMH batteries.
- **WARNING:** The remote control's button cell battery contains mercury. Do not put in the trash, instead recycle or dispose of as hazardous waste
- **WARNING:** Lithium batteries, like all rechargeable batteries, are recyclable and should be recycled or disposed of in normal household waste. Contact your local government for disposal or recycling practices in your area. They should never be incinerated since they might explode.

- **WARNING:** Shock hazard - Do Not Open. *AVIS: Risque de choc électrique - ne pas ouvrir*
- Caution and marking information is located at the rear or bottom of the apparatus. *Attention et de marquage des informations est situé sur le panneau arrière ou inférieur de l'unité.*
- Objects filled with liquids, such as vases, shall not be placed on the apparatus. *Objets remplis de liquides, comme des vases, ne doivent pas être placés sur l'appareil.*
- Mains plug is used as disconnect device and it should remain readily operable during intended use. In order to disconnect the apparatus from the mains completely, the mains plug should be disconnected from the mains socket outlet completely. *La prise du secteur est utilisé pour déconnecter le système. La prise du secteur ne doit pas être obstruée ou doit être facilement accessible pendant son utilisation. Pour être complètement déconnecté de l'alimentation d'entrée, la prise doit être débranchée du secteur.*
- Battery shall not be exposed to excessive heat such as sunshine, fire or the like. *Les piles ne doivent pas être exposées à de forte chaleur, tel qu'à la lumière du soleil, au feu ou autres choses de semblable.*
- Keep new and used batteries away from children. If the battery compartment does not close securely, stop using the product and keep it away from children. *Gardez les piles neuves et d'occasion à partir des enfants. Si le compartiment de la batterie ne pas fermer correctement, cesser d'utiliser le produit et garder loin des enfants.*
- If you think batteries might have been swallowed or placed inside any part of the body, seek immediate medical attention. *Si vous pensez que les batteries peuvent avoir été avalé ou placé à l'intérieur d'une partie du corps, consulter immédiatement un médecin.*
- Do not mix old and new batteries. *Ne pas mélanger vieilles et nouvelles batteries.*
- Completely replace all old batteries with new ones. *Remplacer complètement toutes les piles par des neuves.*
- Do not mix alkaline, standard (carbon-zinc), or rechargeable (ni-cad, ni-mh, etc) batteries. *Ne mélangez pas des piles alcalines, standard (carbène-zinc) ou rechargeables (Ni-Cd, Ni-MH, etc) batteries.*
- Batteries should be recycled or disposed of as per state and local guidelines. *Piles doivent être recyclées ou éliminées selon les directives étatiques et locales.*
- **WARNING:** This product may contain chemicals known to the State of California to cancer, birth defects, or other reproductive harm (California Prop 65).
- This product meets and complies with all Federal Regulations.

To maintain compliance with FCC's RF Exposure guidelines, This equipment should be installed and operated with minimum distance between 20cm the radiator your body: Use only the supplied antenna.

Table of Contents

Introduction & Setup	5
Features	
Power	
Includes	
Orientation	6
Main Features	
Rear Inputs	
Controls	
Operation	8
Playing a Record	
Connecting Devices to the Turntable	10
Pairing a Bluetooth Device	
Playing Audio Wirelessly	
Using the Aux In (3.5mm Audio Input)	
Connecting to External Systems	11
RCA Audio Output	
Company Information	12
Contact Information	
Warranty	
International Support	
Green Initiative	

Introduction & Setup

Features

- 8 inch, 3 speed turntable plays 33 1/3, 78, and 45 rpm records
- Supports Bluetooth
- Wireless range: 60 feet
- Built-in FM radio with up to 20 memory presets
- Aux In 3.5mm audio input
- Built-in speakers
- RCA stereo audio outputs
- LED lighting
- Negative LCD display with blue backlight
- DC power input:
requires an AC/DC power adapter (included)

Includes

- AC/DC power adapter

Power

Plug the small end of the power cord into the DC Input on the back of the unit, and the large plug into a standard wall outlet.

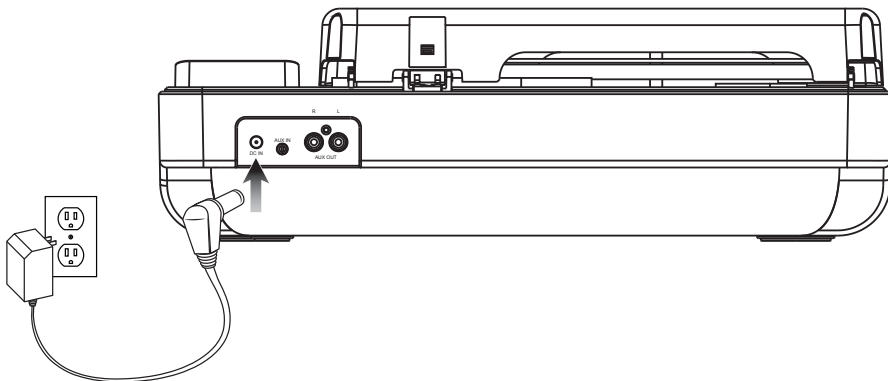

Orientation

Main Features

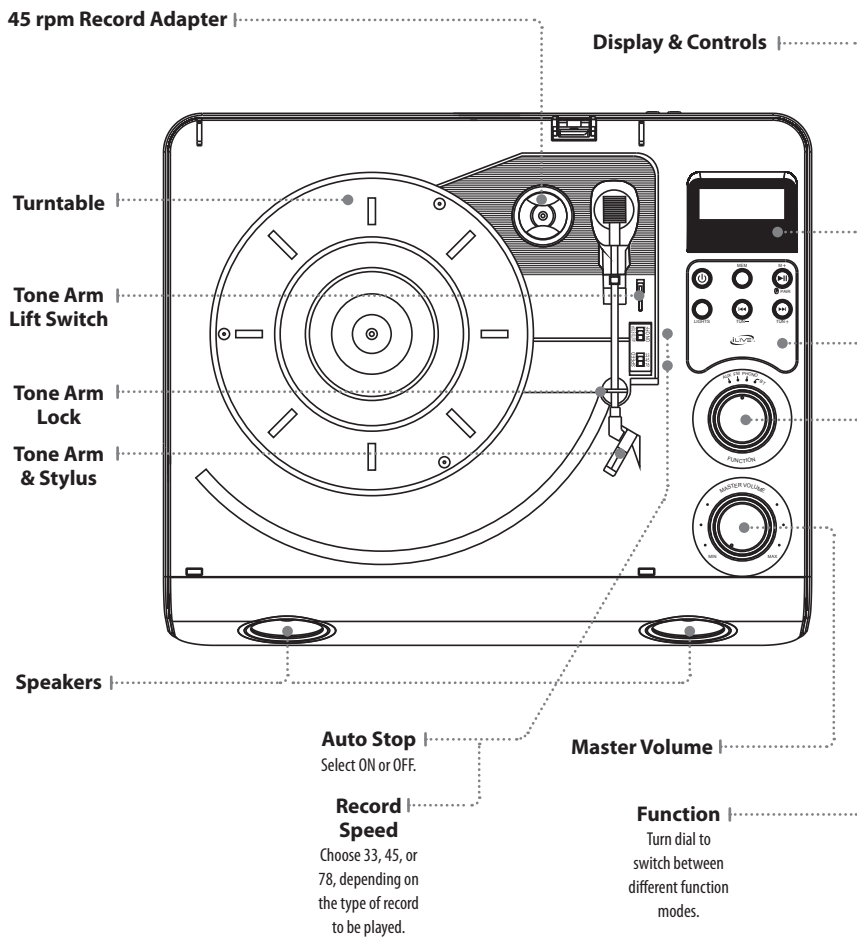

Rear Inputs

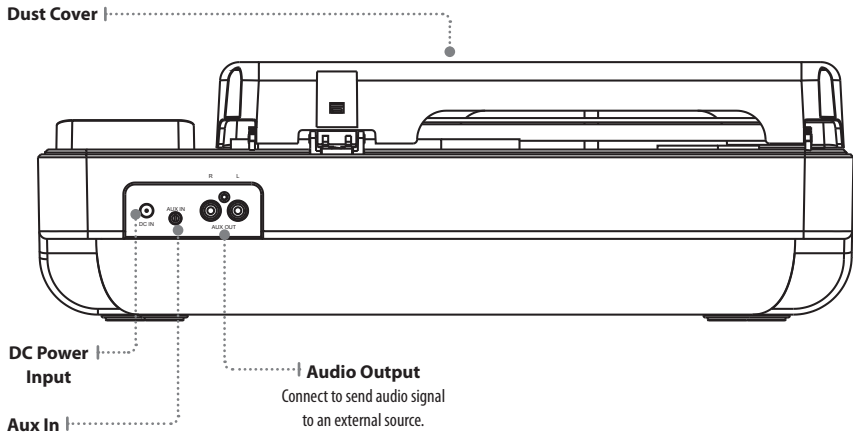

Controls

Power

Press to power the unit ON or OFF.

Mem

Press to begin programming FM memory presets.

M+/Play/Pause/Pair

Press to cycle FM Memory Presets.

Press to play/pause an audio track.

Press and hold to begin pairing to a Bluetooth device.

Lights

Press to activate LED light effects.

Skip Rev/Tun -

Press to skip back an audio track.
In FM Mode, press to adjust down for FM tuning.

Skip Fwd/Tun +

Press to skip ahead an audio track.
In FM Mode, press to adjust up for FM tuning.



Operation

Playing a Record

It is recommended that you use extreme care when manipulating the tone arm, stylus, and other components of this turntable. These parts are very sensitive and can easily break or become damaged if they are carelessly handled.

1. Set the **Source Dial** to **Phono**.
2. Lift open the turntable dust cover, remove the shroud that protects the stylus, and release the lock that holds the Tone Arm in place in its resting position.

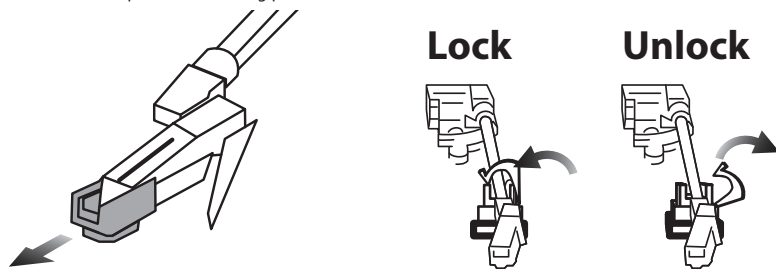

3. Select the correct turntable speed based on the type of record you wish to play, and place the record on the turntable. **If you are playing a 45 rpm record**, use the included adapter and place it between the turntable and the record.

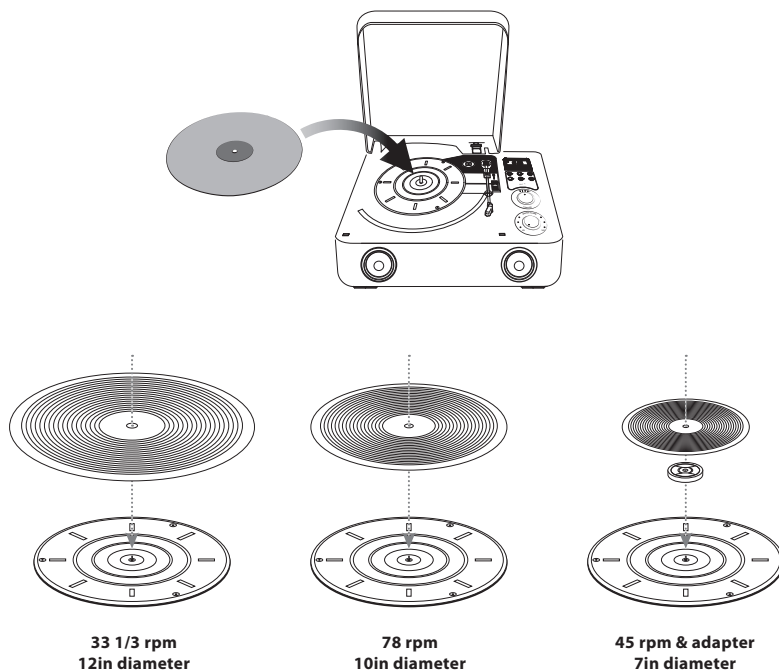

-
4. Use the **Tone Arm Lift Switch** to raise the **Tone Arm** from its catch.
 5. Using your hand, *gently* swing the **Tone Arm** into the desired location over the record. The turntable will start spinning as the Tone Arm is moved into position.
 6. Use the **Tone Arm Lift Switch** to safely lower the stylus onto the record.
Using the Lift Switch instead of your hand will reduce the chance of accidentally damaging the record or the stylus.
 7. Slide the **Auto Stop Switch** to **ON** to enable the Auto Stop feature. When the record is finished playing, it will automatically stop the turntable. Use the **Lift Switch** to raise the stylus off of the record, and *gently* return the Tone Arm to the catch by hand.
Note: Some records place their Auto Stop area outside of the range of this unit. In these cases, the record will stop playing before the last track is reached. Set the Auto Stop Switch to OFF and use the Tone Arm Lift Switch to safely raise the stylus off the record when the end of the record has been reached.
 8. When not in use, secure and lock the Tone Arm in its resting position and replace the protective shroud over the stylus. This will minimize the risk of accidental damage to these sensitive parts.

Connecting Devices to the Turntable

Pairing a Bluetooth Device

1. Set the **Function Dial** to **BT** and press and hold the **Play/Pause/Pair** button.
The pairing indicator will flash blue quickly. When pairing, remain within 3 feet of the unit.
2. Using the controls on your Bluetooth device, search for and select **ITTB775** in your Bluetooth settings to pair. If your device requests a password, enter the default password **0000**.
Refer to the user's manual for your specific device for instructions on pairing and connecting Bluetooth devices.
3. When successfully paired and connected, an audible chime will sound and the **Pairing Indicator** on the display will stop flashing.
*After initial pairing, the unit will stay paired unless unpaired manually by the user or erased due to a reset of the device. If your device should become unpaired or you find it is unable to connect, repeat the above steps or press & hold the **Play/Pause/Pair** button again.*

Playing Audio Wirelessly

1. After pairing to a bluetooth device, use the controls on your connected Bluetooth Device to select a track.
2. Play, pause or skip a selected track using the controls on the connected Bluetooth Device or the controls on the turntable.
3. Audio played through the connected Bluetooth device will now be heard through the speakers.

Using the Aux In (3.5mm Audio Input)

Requires 3.5 mm audio input cable (not included).

1. Plug a 3.5 mm audio input cable into the **Aux In** on the unit and the audio output/headphone output on an MP3 Player or other audio source.
2. Set the **Function Dial** to **Aux** and use the controls on your connected music player to select and play audio.
3. Audio played through the connected device will now be heard through the speakers.

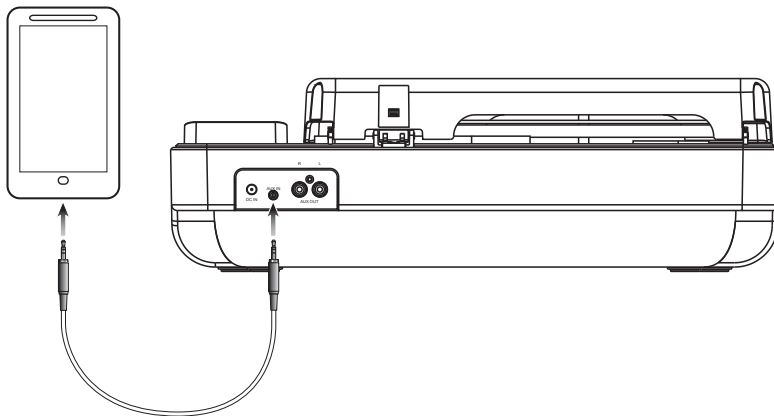

Connecting to External Systems

RCA Audio Output

Requires RCA audio cables (red/white, not included). Use to connect the turntable to an external stereo, television, or other source.

1. Connect RCA audio cables to the **RCA Audio Output** on the back of the turntable, and to the **audio input** of an external stereo system.
2. Adjust the external stereo system to accept input from the turntable.
3. Audio played through the turntable will now be heard through the connected stereo system.

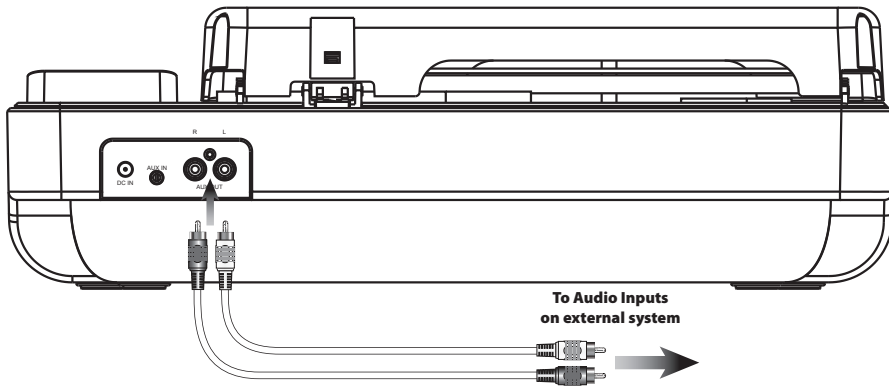

Company Information

Contact Information

Website: www.iLiveElectronics.com

Email Support: prodinfo@dpiinc.com

Email Parts: partsinfo@dpiinc.com

Phone Support: 1-888-999-4215

Warranty

For Warranty Information and the most up-to-date version of this User's Guide, go to:
www.iLiveElectronics.com

International Support

To download this User's Guide in English, Spanish, and French, or to get answers to frequently asked questions, visit the support section at: www.iLiveElectronics.com

Para descargar este Manual del Usuario en inglés, español y francés, o para obtener respuestas a preguntas frecuentes, visite la sección de apoyo en: www.iLiveElectronics.com

Pour télécharger ce guide de l'utilisateur en anglais, espagnol ou français, ou pour obtenir des réponses à des questions fréquemment posées, consultez la rubrique d'assistance sur: www.iLiveElectronics.com

Green Initiative

Our Environmental Commitment to "Protect for Today and Sustain for Tomorrow". On a continual basis DPI, Inc. is making efforts to sustain the environment and improve the recyclability of its products and packaging.

Focusing on "protecting for today and sustaining for tomorrow" DPI, Inc. has committed to reducing packaging size, increasing the usage of recyclable plastics, and ensuring that packaging and manuals are made with up to 85% recycled material. In addition to material consideration, DPI, Inc. has also focused on the finer details that positively impact the environment such as employing the usage of soy-based inks.

DPI, Inc. also ensures that the factories that produce the company's wide variety of consumer electronics adhere to environmentally friendly air and water restrictions. This is yet another example that every step of the way DPI, Inc. is making efforts to lessen any impact on the environment.

In 2011 DPI, Inc. also began conversations with Energy Star in order to ensure that the consumer electronics being produced meet high standards of energy efficiency. The ultimate goal is keeping energy costs for consumers low while providing quality, feature-rich products.



Copyright © 2015 Digital Products International (DPI, Inc.) All other trademarks appearing herein are the property of their respective owners. Specifications are subject to change without notice.