

FCC PART 15C TEST REPORT FOR CERTIFICATION

On Behalf of

Modern Electronics Factory Limited

Universal Multi-Charging Station

Brand Name	Model No.
DOK	CR13
DOK	CR10, CR11, CR12, CR15, CR16, CR17, CR18, CR22, CR23, CR28, CR33
BRAND	CR10, CR11, CR12, CR13
MET, IXT, KARAOKE USA	CR10, CR11, CR12, CR13, CR15, CR16, CR17, CR18, CR22, CR23, CR28, CR33

FCC ID: SSM393013

Prepared for : Modern Electronics Factory Limited
Flat C, 10/F., Phase 4, Kwun Tong Ind .Centre ,472-482
Kwun Tong RD ,Kwun Tong ,KLN ,Hong Kong

Prepared By : Audix Technology (Shenzhen) Co., Ltd.
No. 6, Ke Feng Rd., 52 Block,
Shenzhen Science & Industrial Park,
Nantou, Shenzhen, Guangdong, China

Tel: (0755) 26639496

Report Number : ACS-F13242

Date of Test : Aug.09~14, 2013

Date of Report : Aug.27, 2013

TABLE OF CONTENTS

Description	Page
1. SUMMARY OF STANDARDS AND RESULTS.....	1-1
1.1. Description of Standards and Results	1-1
2. GENERAL INFORMATION	2-1
2.1. Description of Device (EUT).....	2-1
2.2. Tested Supporting System Details	2-2
2.3. EUT Configuration and operation conditions for test.....	2-2
2.4. Test Facility	2-3
2.5. Measurement Uncertainty (95% confidence levels, k=2)	2-3
3. POWER LINE CONDUCTED EMISSION TEST	3-1
3.1. Test Equipments.....	3-1
3.2. Block Diagram of Test Setup.....	3-1
3.3. Power Line Conducted Emission Test Limits.....	3-1
3.4. Configuration of EUT on Test	3-2
3.5. Operating Condition of EUT.....	3-2
3.6. Test Procedure.....	3-2
3.7. Power Line Conducted Emission Test Results	3-2
4. RADIATED EMISSION TEST	4-3
4.1. Test Equipment	4-3
4.2. Block Diagram of Test Setup.....	4-3
4.3. Radiated Emission Limit Standard: FCC 15.209 & 249	4-4
4.4. EUT Configuration on Test.....	4-5
4.5. Operating Condition of EUT.....	4-5
4.6. Test Procedure.....	4-5
4.7. Radiated Emission Test Results	4-6
5. CONDUCTED SPURIOUS EMISSIONS.....	5-1
5.1. Test Equipment	5-1
5.2. Limit.....	5-1
5.3. Test Procedure.....	5-1
5.4. Test result.....	5-1
6. CARRIER FREQUENCY SEPARATION TEST	6-1
6.1. Test Equipment	6-1
6.2. Limit.....	6-1
6.3. Test Results	6-1
7. 20 DB BANDWIDTH TEST	7-1
7.1. Test Equipment	7-1
7.2. Limit.....	7-1
7.3. Test Results	7-1
8. NUMBER OF HOPPING FREQUENCY TEST	8-1
8.1. Test Equipment	8-1
8.2. Limit.....	8-1
8.3. Test Results	8-1
9. DWELL TIME	9-1
9.1. Test Equipment	9-1
9.2. Limit.....	9-1
9.3. Test Results	9-1

10.	MAXIMUM PEAK OUTPUT POWER TEST	10-1
10.1.	Test Equipment	10-1
10.2.	Limit.....	10-1
10.3.	Test Procedure.....	10-1
10.4.	Test Results	10-2
11.	BAND EDGE COMPLIANCE TEST	11-1
11.1.	Test Equipment	11-1
11.2.	Limit.....	11-1
11.3.	Test Produce	11-1
11.4.	Test Results	11-2
12.	DEVIATION TO TEST SPECIFICATIONS.....	12-1
13.	PHOTOGRAPH OF TEST	13-1
13.1.	Photos of Conducted Disturbance at Mains Terminals Test	13-1
13.2.	Photos of Radiated Emission Test.....	13-2
14.	PHOTOS OF THE EUT	14-1

TEST REPORT CERTIFICATION

Applicant : Modern Electronics Factory Limited
 Manufacturer : Modern Electronics Factory Limited
 EUT Description : Universal Multi-Charging Station
 FCC ID : SSM393013

(A) MODEL NO. &
 BRAND NAME :

Brand Name	Model No.
DOK	CR13
DOK	CR10, CR11, CR12, CR15, CR16, CR17, CR18, CR22, CR23, CR28, CR33
BRAND	CR10, CR11, CR12, CR13
MET, IXT, KARAOKE USA	CR10, CR11, CR12, CR13, CR15, CR16, CR17, CR18, CR22, CR23, CR28, CR33

(B) POWER SUPPLY : DC 5V From Adapter

(C) TEST VOLTAGE : DC 5V From Adapter Input AC 120V/60Hz

Tested for comply with:

FCC Rules and Regulations Part 15 Subpart C: 2012

Test procedure used: ANSI C63.10:2009

The device described above is tested by AUDIX TECHNOLOGY (SHENZHEN) CO., LTD. to confirm comply with all the FCC Part 15 Subpart C requirements.

The test results are contained in this test report and AUDIX TECHNOLOGY (SHENZHEN) CO., LTD. is assumed full responsibility for the accuracy and completeness of these tests. This report contains data that are not covered by the NVLAP accreditation. Also, this report shows that the Equipment Under Test (EUT) is to be technically compliant with the FCC requirements.

This Report is made under FCC Part 2.1075. No modifications were required during testing to bring this product into compliance.

This report applies to above tested sample only. This report shall not be reproduced in part without written approval of AUDIX TECHNOLOGY (SHENZHEN) CO., LTD.

The report must not be used by the client to claim product certification, approval, or endorsement by NVLAP, NIST, or any agency of the federal government.

Date of Test : Aug.09~ 14, 2013 Report of date: Aug.27, 2013

Prepared by : Lisa Liang
 Lisa Liang / Assistant

 信華科技(深圳)有限公司 Audix Technology (Shenzhen) Co., Ltd. EMC 部門報告專用章	Reviewed by: <u>Sunny Lu</u> Sunny Lu / Assistant Manager
	Stamp only for EMC Dept. Report Signature: <u>David Jin</u>

Approved & Authorized Signer :

David Jin / Manager

1. SUMMARY OF STANDARDS AND RESULTS

1.1. Description of Standards and Results

The EUT have been tested according to the applicable standards as referenced below.

EMISSION		
Description of Test Item	Standard	Results
Power Line Conducted Emission Test	FCC Part 15: 15.207 ANSI C63.10 :2009	PASS
Radiated Emission Test	FCC Part 15: 15.209 FCC Part 15: 15.247(d) ANSI C63.10 :2009	PASS
Conducted Spurious Emissions	FCC Part 15: 15.247(a)(1) ANSI C63.10 :2009	PASS
Carrier Frequency Separation Test	FCC Part 15: 15.247(a)(1) ANSI C63.10 :2009	PASS
20dB Bandwidth Test	FCC Part 15: 15.215 ANSI C63.10 :2009	PASS
Number Of Hopping Frequency Test	FCC Part 15: 15.247(a)(1)(iii) ANSI C63.10 :2009	PASS
Dwell Time Test	FCC Part 15: 15.247(a)(1)(iii) ANSI C63.10 :2009	PASS
Maximum Peak Output Power Test	FCC Part 15: 15.247(b)(1)\ ANSI C63.10 :2009	PASS
Band Edge Compliance Test	FCC Part 15: 15.247(d) ANSI C63.10 :2009	PASS

2. GENERAL INFORMATION

2.1. Description of Device (EUT)

Product Name : Universal Multi-Charging Station

Model No. &
Brand Name

Brand Name	Model No.
DOK	CR13
DOK	CR10, CR11, CR12, CR15, CR16, CR17, CR18, CR22, CR23, CR28, CR33
BRAND	CR10, CR11, CR12, CR13
MET, IXT, KARAOKE USA	CR10, CR11, CR12, CR13, CR15, CR16, CR17, CR18, CR22, CR23, CR28, CR33

The deference is just the model name and color.

Test Model : CR13

FCC ID : SSM393013

Radio : Bluetooth V2.1+EDR

Operation frequency : 2402MHz~2480MHz

Antenna : IFA, 0dBi PK gain

Modulation : GFSK, $\pi/4$ DQPSK, 8-DPSK

Power Supply : DC 5V From Adapter Input AC 120V/60Hz

Applicant : Modern Electronics Factory Limited
Flat C, 10/F., Phase 4, Kwun Tong Ind. Centre ,472-482 Kwun
Tong RD ,Kwun Tong ,KLN ,Hong Kong

Manufacturer : Modern Electronics Factory Limited
Flat C, 10/F., Phase 4, Kwun Tong Ind. Centre ,472-482 Kwun
Tong RD ,Kwun Tong ,KLN ,Hong Kong

Power Adapter : Manufacturer : JIEDONG ELECTRON FACTORY
M/N: JDA0300500350WUS
Input :100-240V~ 50/60Hz, 0.8A
Output: 5.0V, 3.5A
Shielded, Detachable, 1.8m

Audio In : Unshielded, Detachable, 0.58m

Date of Test : Aug.09~14, 2013

Date of Receipt : Aug.07, 2013

Sample Type : Prototype production

2.2. Tested Supporting System Details

No.	Description	ACS No.	Manufacturer	Model	Serial Number	Approved type
1.	iPod nano	ACS-EMC-IP01	APPLE	A1199	YM706MLDVQ5	<input checked="" type="checkbox"/> FCC DoC <input checked="" type="checkbox"/> BSMI ID: R33057
		Data Cable: Shielded, Detachable, 1.0m				
2.	MP3	--	SONY	NOVE-S540	--	<input type="checkbox"/> FCC ID <input type="checkbox"/> BSMI ID
		Data Cable: Shielded, Detachable, 1.8m Power Cord: Unshielded, Detachable, 1.8m				
3.	Mobile phone	--	HTC	S720e	--	<input type="checkbox"/> FCC ID By DoC <input type="checkbox"/> BSMI ID R33057

2.3. EUT Configuration and operation conditions for test.

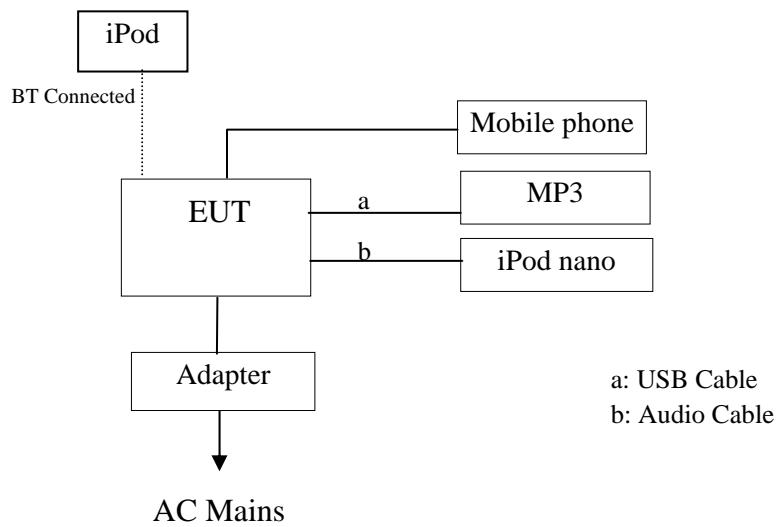

(EUT: Universal Multi-Charging Station)

2.4. Test Facility

Site Description

Name of Firm : Audix Technology (Shenzhen) Co., Ltd.
No. 6, Ke Feng Rd., 52 Block, Shenzhen
Science & Industrial Park, Nantou,
Shenzhen, Guangdong, China

3m Anechoic Chamber : Certificated by FCC, USA
Registration Number: 90454
Valid Date: Feb.22, 2015

3m & 10m Anechoic Chamber : Certificated by FCC, USA
Registration Number: 794232
Valid Date: Oct.31, 2015

EMC Lab. : Certificated by Industry Canada
Registration Number: IC 5183A-1
Valid Date: Jun.13, 2014

Certificated by DAkkS, Germany
Registration No: D-PL-12151-01-01
Valid Date: Feb.01, 2014

Accredited by NVLAP, USA
NVLAP Code: 200372-0
Valid Date: Mar.31, 2014

2.5. Measurement Uncertainty (95% confidence levels, k=2)

Test Item	Uncertainty
Uncertainty for Conduction emission test in No. 1 Conduction	3.1 dB(150kHz to 30MHz)
Uncertainty for Radiation Emission test in 3m chamber	3.02 dB (9KHz~30MHz, Polarize: H)
	3.03 dB (9KHz~30MHz, Polarize: V)
	3.22 dB(30~200MHz, Polarize: H)
	3.23 dB(30~200MHz, Polarize: V)
	3.49dB(200M~1GHz, Polarize: H)
Uncertainty for Radiation Emission test in 3m chamber (1GHz-18GHz)	3.39 dB(200M~1GHz, Polarize: V)
	5.04dB (1~6GHz,Distance: 3m)
Uncertainty for Radiated Spurious Emission test in RF chamber	5.06dB (6~18GHz,Distance: 3m)
	3.57dB
Uncertainty for Conduction Spurious emission test	2.00 dB
Uncertainty for Output power test	0.73 dB
Uncertainty for Power density test	2.00 dB
Uncertainty for Frequency range test	7×10^{-8}
Uncertainty for Bandwidth test	83 kHz
Uncertainty for DC power test	0.038 %
Uncertainty for test site temperature and humidity	0.6°C
	3%

3. POWER LINE CONDUCTED EMISSION TEST

3.1. Test Equipments

Item	Equipment	Manufacturer	Model No.	Serial No.	Last Cal.	Cal. Interval
1.	Test Receiver	Rohde & Schwarz	ESHS10	838693/001	Oct.31, 12	1 Year
2.	L.I.S.N.#1	Rohde & Schwarz	ESH2-Z5	834066/011	Oct.31, 12	1 Year
3.	L.I.S.N.#3	Kyoritsu	KNW-242C	8-1920-1	May.08, 13	1 Year
4.	Terminator	Hubersuhner	50Ω	No. 1	May.08, 13	1 Year
5.	Terminator	Hubersuhner	50Ω	No. 2	May.08, 13	1 Year
6.	RF Cable	Fujikura	3D-2W	No.1	May.08, 13	1Year
7.	Coaxial Switch	Anritsu	MP59B	M50564	May.08, 13	1 Year
8.	Pulse Limiter	Rohde & Schwarz	ESH3-Z2	100341	May.08, 13	1 Year

3.2. Block Diagram of Test Setup

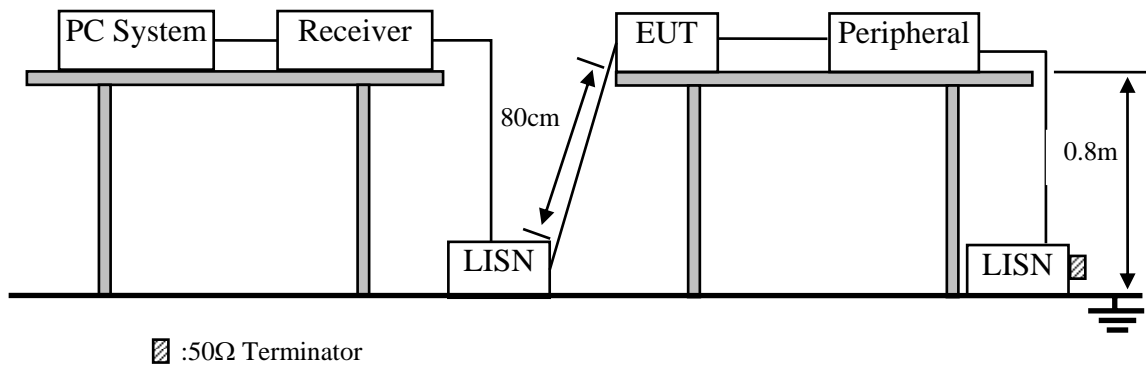

3.3. Power Line Conducted Emission Test Limits

Frequency	Maximum RF Line Voltage	
	Quasi-Peak Level dB(μV)	Average Level dB(μV)
150kHz ~ 500kHz	66 ~ 56*	56 ~ 46*
500kHz ~ 5MHz	56	46
5MHz ~ 30MHz	60	50

Notes: 1. * Decreasing linearly with logarithm of frequency.

2. The lower limit shall apply at the transition frequencies.

3.4. Configuration of EUT on Test

The following equipment are installed on Power Line Conducted Emission Test to meet the commission requirement and operating regulations in a manner which tends to maximize its emission characteristics in a normal application.

3.4.1. Universal Multi-Charging Station (EUT)

Model Number : CR13
Serial Number : N/A

3.4.2. Support Equipment: As Tested Supporting System Details, in Section 2.3.

3.5. Operating Condition of EUT

3.5.1. Setup the EUT and simulator as shown as Section 2.4.

3.5.2. Turned on the power of all equipment.

3.5.3. PC run test software to control EUT work in Tx mode.

3.6. Test Procedure

The EUT was placed on a non-metallic table, 80cm above the ground plane. The EUT Power connected to the power mains through a line impedance stabilization network (L.I.S.N. 1#). The other peripheral devices power cord connected to the power mains through a line impedance stabilization network (L.I.S.N.#3). This provides a 50 ohm coupling impedance for the EUT (Please refer the block diagram of the test setup and photographs). The AC line are checked to find out the maximum conducted emission. In order to find the maximum emission levels, the relative positions of equipment and all of the interface cables shall be changed according to ANSI C63.10: 2009 on Conducted Emission Test.

The bandwidth of test receiver (R & S ESHS10) is set at 10kHz.

The frequency range from 150kHz to 30MHz is checked.

3.7. Power Line Conducted Emission Test Results

PASS. (All emissions not reported below are too low against the prescribed limits.)

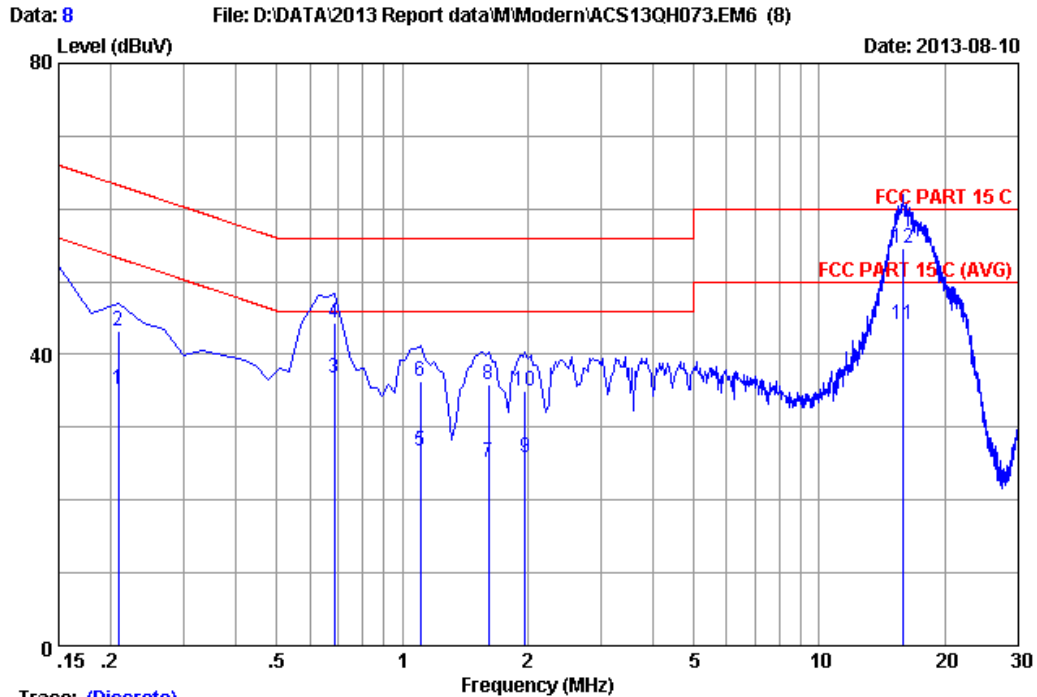

Trace: (Discrete)

Site no :1#conduction Data No :8
 Dis./Ant. **: 2012 ESH2-Z5 LINE
 Limit :FCC PART 15 C
 Env./Ins. :24.5°C/56% Engineer :Leo-LI
 EUT :Universal Multi-Charging Station
 Power Rating :DC 5V From Adapter Input AC 120V/60Hz
 Test Mode :Tx Mode
 :M/N:CR13
 :

No	Freq (MHz)	LISN Factor (dB)	Cable Loss (dB)	Reading (dBuV)	Emission Level (dBuV)	Limits (dBuV)	Margin (dB)	Remark
1	0.20900	0.19	0.01	35.00	35.20	53.24	18.04	Average
2	0.20900	0.19	0.01	43.00	43.20	63.24	20.04	QP
3	0.68700	0.20	0.03	36.60	36.83	46.00	9.17	Average
4	0.68700	0.20	0.03	44.20	44.43	56.00	11.57	QP
5	1.105	0.21	0.03	26.60	26.84	46.00	19.16	Average
6	1.105	0.21	0.03	36.00	36.24	56.00	19.76	QP
7	1.612	0.23	0.04	24.89	25.16	46.00	20.84	Average
8	1.612	0.23	0.04	35.69	35.96	56.00	20.04	QP
9	1.970	0.24	0.04	25.50	25.78	46.00	20.22	Average
10	1.970	0.24	0.04	34.70	34.98	56.00	21.02	QP
11	15.910	0.82	0.12	43.10	44.04	50.00	5.96	Average
12	15.910	0.82	0.12	53.70	54.64	60.00	5.36	QP

Remarks: 1.Emission Level=LISN Factor+Cable Loss+Reading.
 2.If the average limit is met when using a quasi-peak detector, the EUT shall be deemed to meet both limits and measurement with average detector is unnecessary.

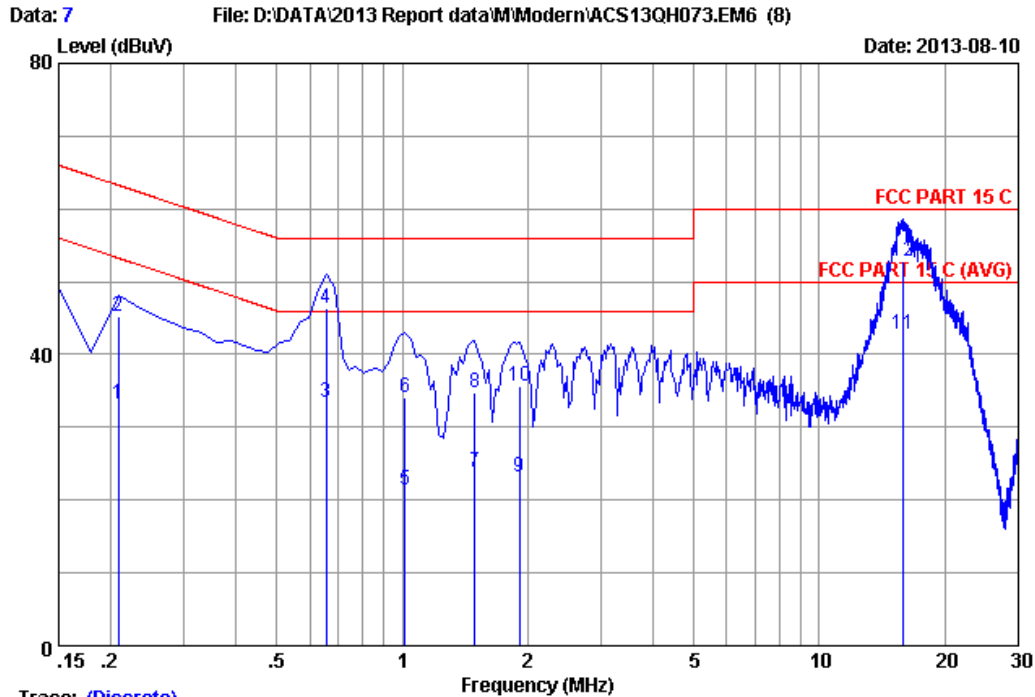

Trace: (Discrete)

Site no :1#conduction Data No :7
 Dis./Ant. **: 2012 ESH2-Z5 NEUTRAL
 Limit :FCC PART 15 C
 Env./Ins. :24.5°C/56% Engineer :Leo-LI
 EUT :Universal Multi-Charging Station
 Power Rating :DC 5V From Adapter Input AC 120V/60Hz
 Test Mode :Tx Mode
 :M/N:CR13
 :

No	Freq (MHz)	LISN Factor (dB)	Cable Loss (dB)	Reading (dBuV)	Emission Level (dBuV)	Limits (dBuV)	Margin (dB)	Remark
1	0.20900	0.21	0.01	32.90	33.12	53.24	20.12	Average
2	0.20900	0.21	0.01	45.10	45.32	63.24	17.92	QP
3	0.65700	0.24	0.03	33.09	33.36	46.00	12.64	Average
4	0.65700	0.24	0.03	45.99	46.26	56.00	9.74	QP
5	1.015	0.24	0.03	21.20	21.47	46.00	24.53	Average
6	1.015	0.24	0.03	33.90	34.17	56.00	21.83	QP
7	1.493	0.26	0.03	23.51	23.80	46.00	22.20	Average
8	1.493	0.26	0.03	34.41	34.70	56.00	21.30	QP
9	1.911	0.28	0.04	22.90	23.22	46.00	22.78	Average
10	1.911	0.28	0.04	35.30	35.62	56.00	20.38	QP
11	15.851	0.71	0.12	41.91	42.74	50.00	7.26	Average
12	15.851	0.71	0.12	52.01	52.84	60.00	7.16	QP

Remarks: 1.Emission Level=LISN Factor+Cable Loss+Reading.
 2.If the average limit is met when using a quasi-peak detector, the EUT shall be deemed to meet both limits and measurement with average detector is unnecessary.

4. RADIATED EMISSION TEST

4.1. Test Equipment

Frequency rang: 30~1000MHz

Item	Equipment	Manufacturer	Model No.	Serial No.	Last Cal.	Cal. Interval
1	3#Chamber	AUDIX	N/A	N/A	Nov.24,12	1 Year
2	EMI Spectrum	Agilent	E4407B	MY41440292	May.08, 13	1 Year
3	Test Receiver	Rohde & Schwarz	ESVS10	834468/011	May.08, 13	1 Year
4	Amplifier	HP	8447D	2648A04738	May.08, 13	1 Year
5	Bilog Antenna	Schaffner	CBL6111C	2598	Mar.14,13	1 Year
6	RF Cable	MIYAZAKI	CFD400-NL	3# Chamber No.1	May.08, 13	1 Year
7	Coaxial Switch	Anritsu	MP59B	M74389	May.08, 13	1 Year
8	Loop Antenna	Chase	HLA6120	1062	May.21,13	1 Year

Frequency rang: above 1000MHz

Item	Equipment	Manufacturer	Model No.	Serial No.	Last Cal.	Cal. Interval
1	Spectrum Analyzer	Agilent	E4407B	MY41440292	May.08, 13	1 Year
2	Horn Antenna	EMCO	3115	9607-4877	Aug.28, 13	1 Year
3	Amplifier	Agilent	8449B	3008A00863	May.08, 13	1 Year
4	RF Cable	Hubersuhner	SUCOFLEX106	77980/6	May.08, 13	1 Year
5	RF Cable	Hubersuhner	SUCOFLEX106	77977/6	May.08, 13	1 Year
6	Horn Antenna	EMCO	3116	00060088	June.05,13	1 Year

4.2. Block Diagram of Test Setup

For frequency range 30MHz-1000MHz

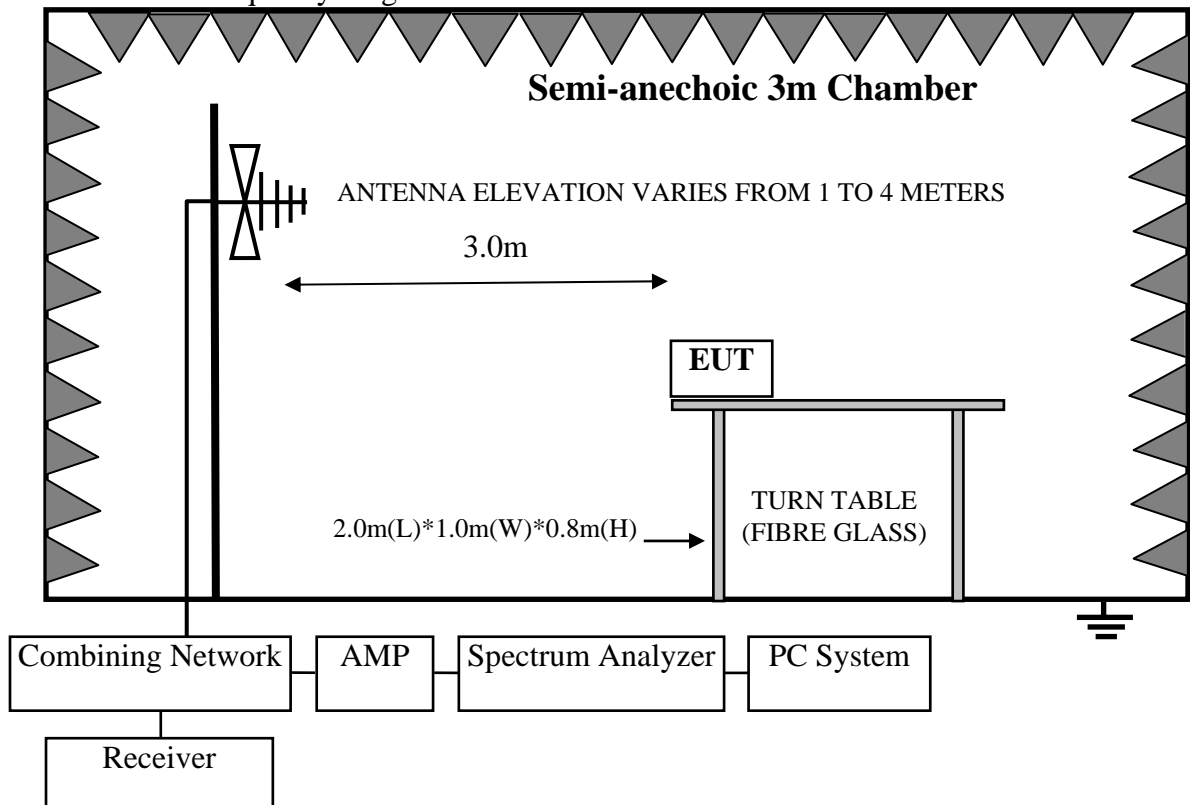

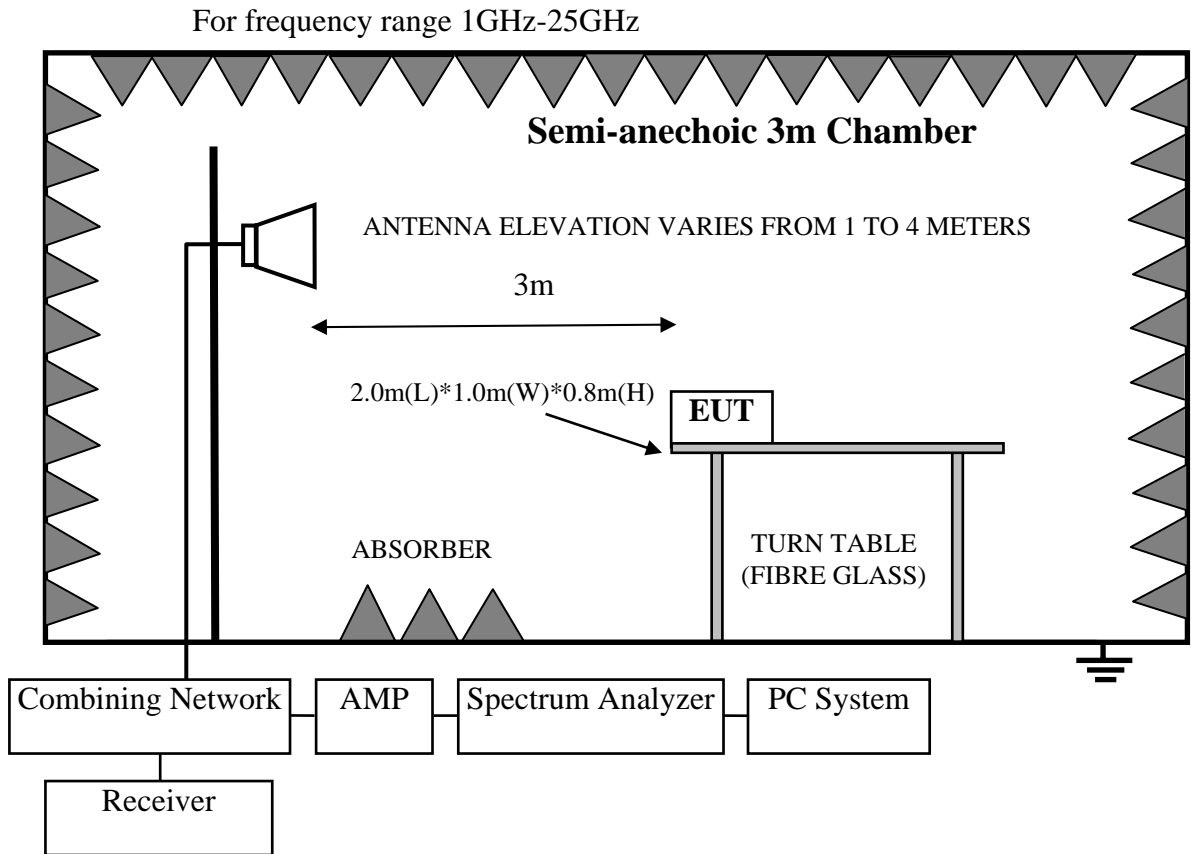

4.3. Radiated Emission Limit Standard: FCC 15.209 & 249

FREQUENCY MHz	DISTANCE Meters	FIELD STRENGTHS LIMIT	
		$\mu\text{V}/\text{m}$	$\text{dB}(\mu\text{V})/\text{m}$
30 ~ 88	3	100	40.0
88 ~ 216	3	150	43.5
216 ~ 960	3	200	46.0
960 ~ 1000	3	500	54.0
Above 1000MHz	3	74.0 $\text{dB}(\mu\text{V})/\text{m}$ (Peak) 54.0 $\text{dB}(\mu\text{V})/\text{m}$ (Average)	

Remark : (1) Emission level $\text{dB}\mu\text{V} = 20 \log$ Emission level $\mu\text{V}/\text{m}$

- (2) The smaller limit shall apply at the cross point between two frequency bands.
- (3) Distance is the distance in meters between the measuring instrument, antenna and the closest point of any part of the device or system.
- (4) The emission limits shown in the above table are based on measurements employing a CISPR quasi-peak detector except for the frequency bands 9-90 kHz, 110-490 kHz and above 1000 MHz. Radiated emission limits in these three bands are based on measurements employing an average detector.

4.4. EUT Configuration on Test

The following equipment are installed on Radiated Emission Test to meet the commission requirements and operating regulations in a manner which tends to maximize its emission characteristics in normal application.

4.4.1. Universal Multi-Charging Station (EUT)

Model Number : CR13
Serial Number : N/A

4.4.2. Support Equipment : As Tested Supporting System Detail, in Section 2.4

4.5. Operating Condition of EUT

4.5.1. Setup the EUT and simulator as shown as Section 4.2.

4.5.2. Turned on the power of all equipment.

4.5.3. Let EUT work in Tx mode.

4.6. Test Procedure

The EUT and its simulators are placed on a turn table, which is 0.8 meter high above ground. The turn table can rotate 360 degrees to determine the position of the maximum emission level. The EUT is set 3 meters away from the receiving antenna, which is mounted on a antenna tower. The antenna can be moved up and down between 1 meter and 4 meters to find out the maximum emission level. Broadband antenna (calibrated bilog antenna) is used as receiving antenna. Both horizontal and vertical polarization of the antenna is set on Test. In order to find the maximum emission levels, all of the interface cables must be manipulated according to ANSI C63.10-2009 on radiated emission Test.

This test was performed with EUT in X, Y, Z position, and the worse case was found when EUT in X position as the test photo indicated.

There is no obvious emission in the range 9KHz~30MHz, so the emission result was not record in the report. All emission in the range 9KHz~30MHz are at least 20dB below limit; emission plot was not recorded in the report.

The bandwidth of the EMI test receiver (R&S ESVS10) is set at 120kHz for frequency range from 30MHz to 1000 MHz.

The bandwidth of the Spectrum's RBW is set at 1MHz and VBW is set at 3MHz for peak emissions measurement above 1GHz

This device is pulse modulated, a duty cycle factor was used to calculate average level based measured peak level.

The frequency range from 30MHz to 10th harmonic (25GHz) are checked. and no any emissions were found from 18GHz to 25 GHz, So the radiated emissions from 18GHz to 25GHz were not record.

4.7.Radiated Emission Test Results

PASS.

All the emissions from 30MHz to 25GHz were comply with the 15.247 Limit.

Note: The duty cycle factor for calculate average level is 9.37 dB, and average limit is 20dB below peak limit, so if peak measured level comply with average limit, the average level was deemed to comply with average limit.

Duty cycle: $0.426\text{ms} / 1.251\text{ms} * 100\% = 34\%$

Duty cycle factor = $20\log (1/\text{duty cycle}) = 9.37$

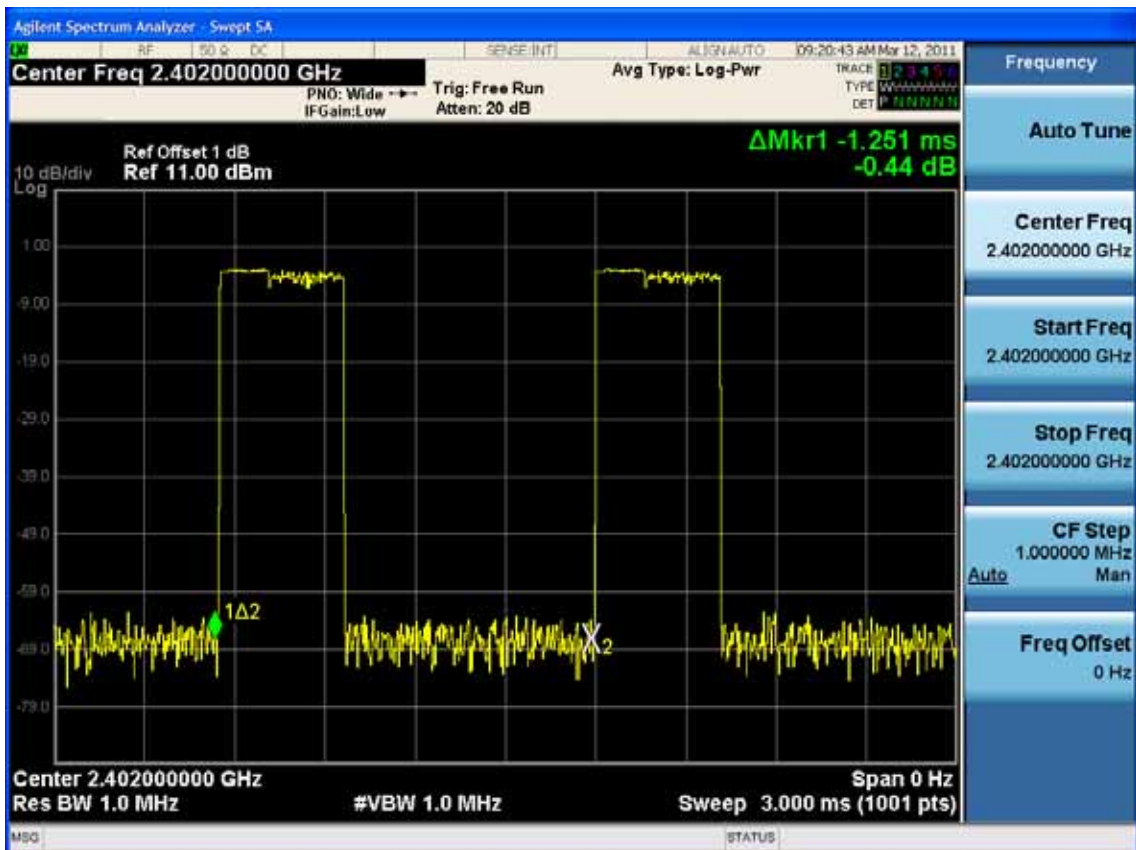
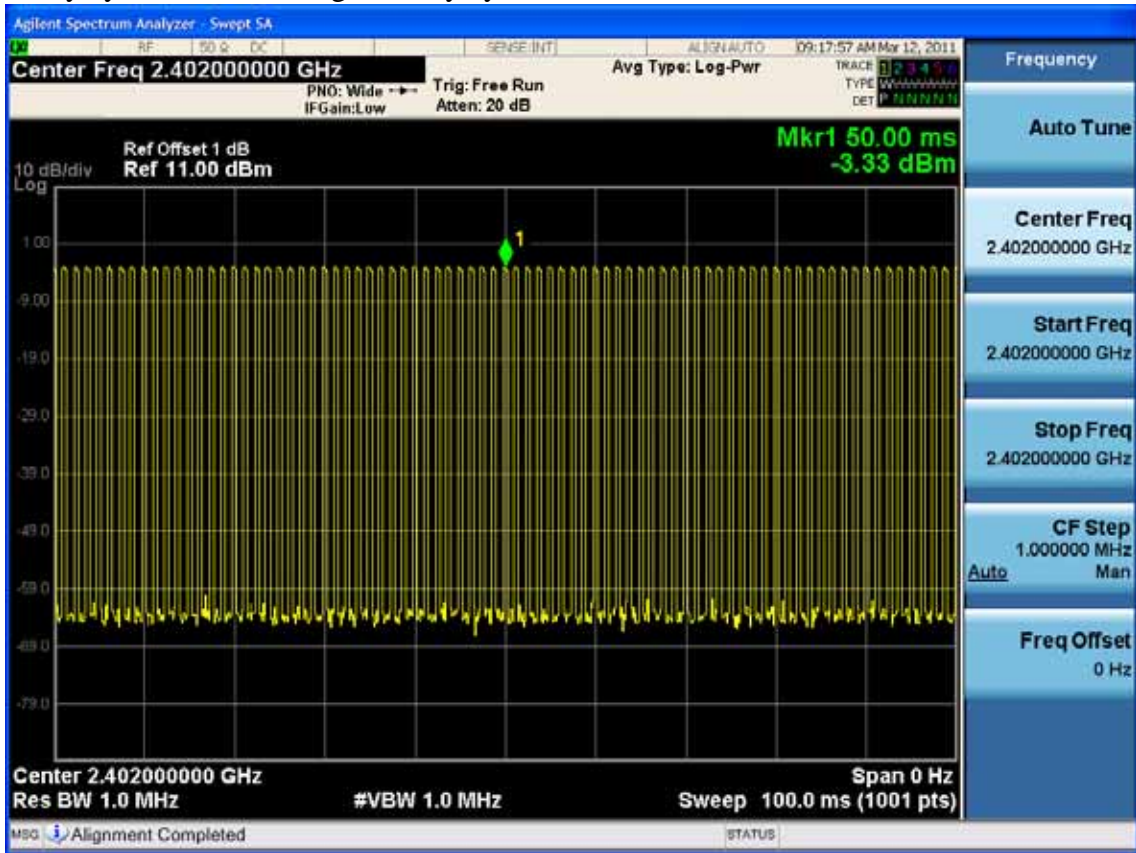

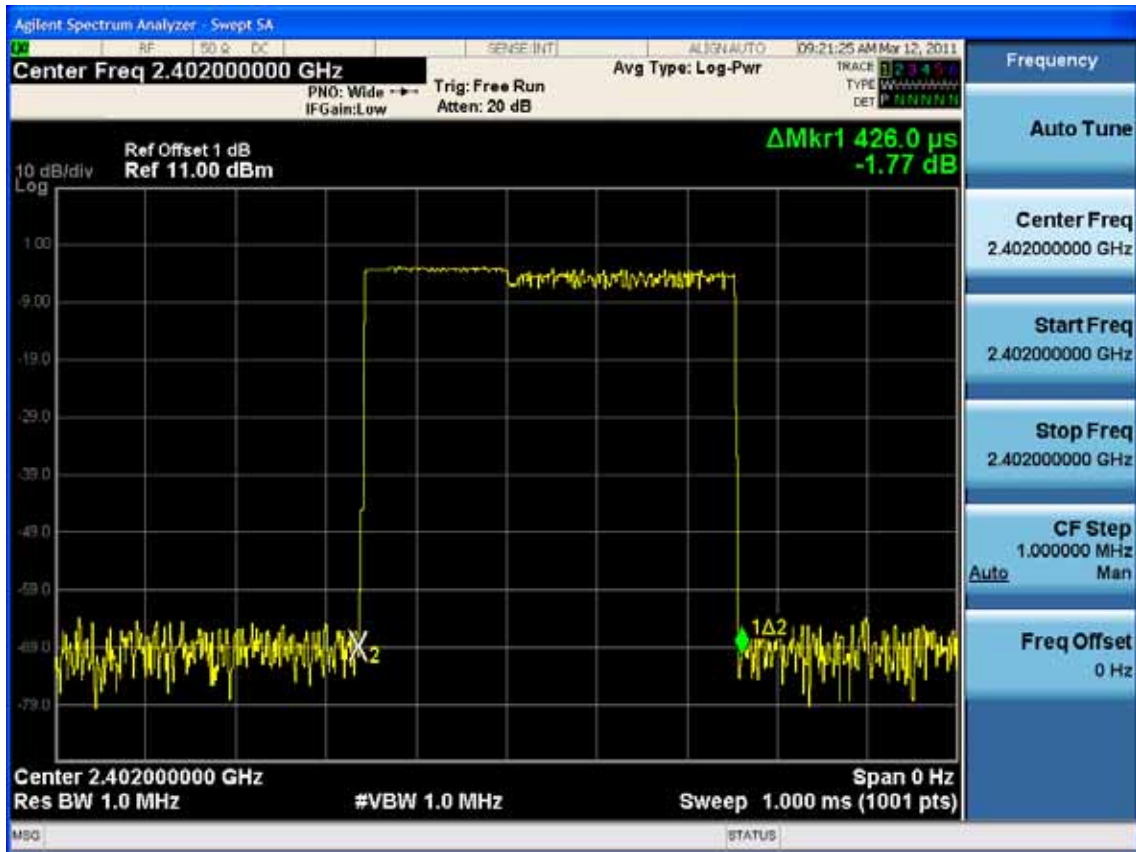

Frequency: 30MHz~1GHz

Data: 9

File: E:\2013 Report Data\M\Modern\ACS13QH073.EM6 (12)

Date: 2013-08-09

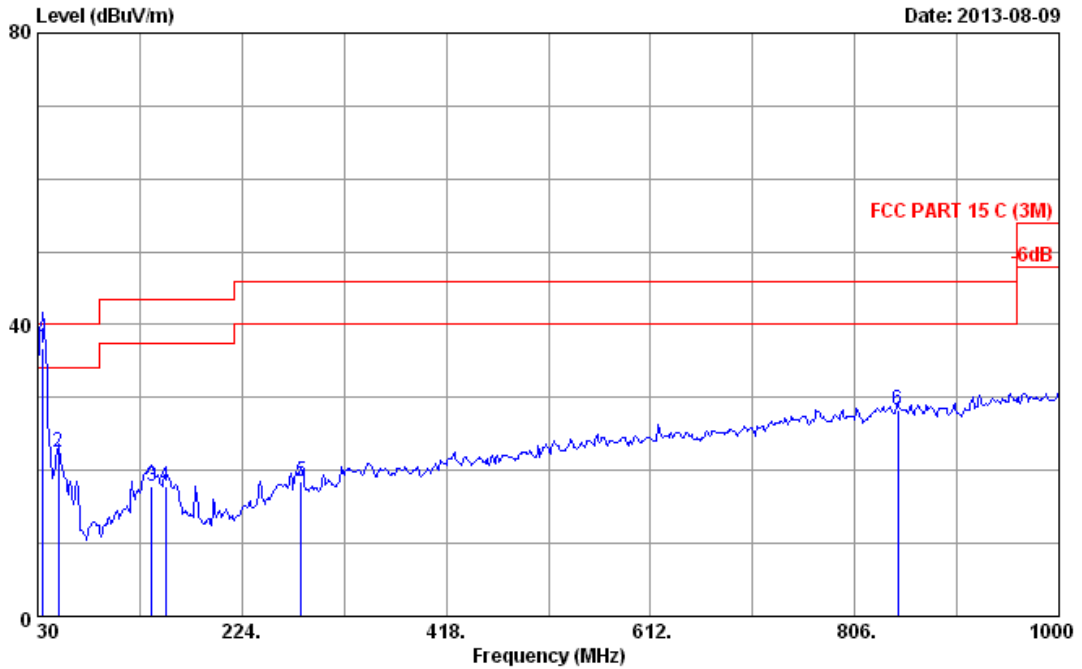

Site no. : 3m Chamber Data no. : 9
 Dis. / Ant. : 3m 2013 CBL6111C 2598 Ant. pol. : VERTICAL
 Limit : FCC PART 15 C (3M)
 Env. / Ins. : 24°C/65% Engineer : Even_Deng
 EUT : Universal Multi-Charging Station
 Power rating : DC 5V From Adapter Input AC 120V/60Hz
 Test Mode : Tx Mode
 M/N:CR13

No.	Freq. (MHz)	Ant. Factor (dB/m)	Cable Loss (dB)	Reading (dBuV)	Emission Level (dBuV/m)	Limits (dBuV/m)	Margin (dB)	Remark
1	34.850	17.13	0.92	18.70	36.75	40.00	3.25	QP
2	49.400	9.23	1.18	12.11	22.52	40.00	17.48	QP
3	138.640	12.27	1.56	3.96	17.79	43.50	25.71	QP
4	151.250	11.74	1.60	4.59	17.93	43.50	25.57	QP
5	280.260	13.21	2.09	3.28	18.58	46.00	27.42	QP
6	846.740	22.90	3.76	1.68	28.34	46.00	17.66	QP

Remarks: 1. Emission Level= Antenna Factor + Cable Loss + Reading.
 2. The emission levels that are 20dB below the official limit are not reported.

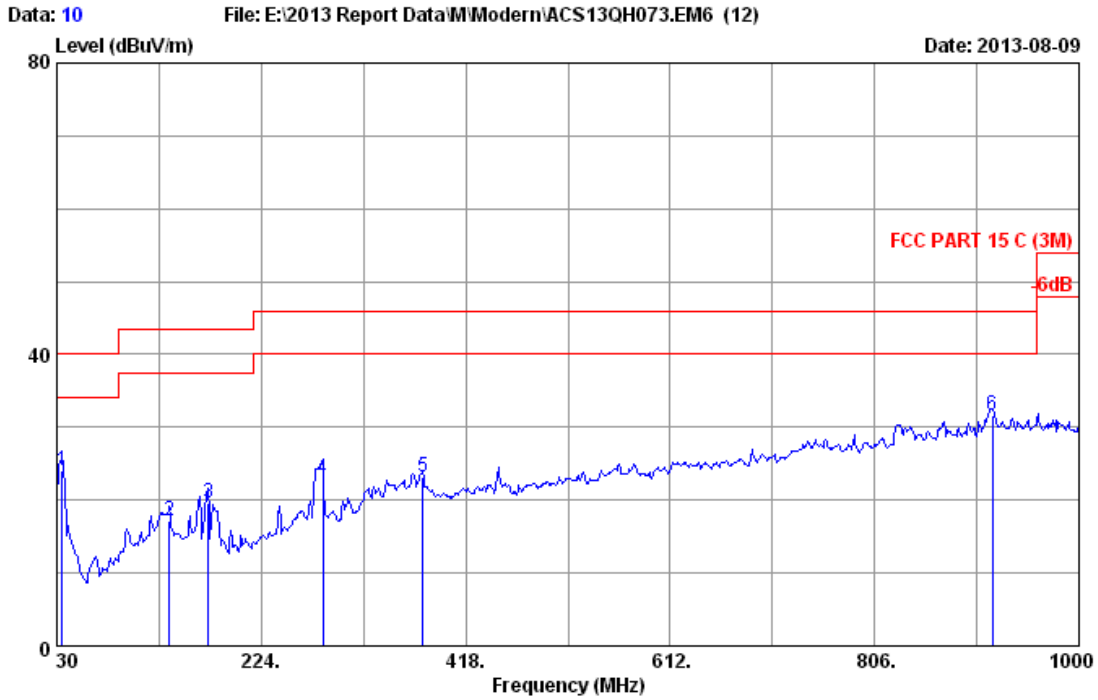

Site no. : 3m Chamber Data no. : 10
 Dis. / Ant. : 3m 2013 CBL6111C 2598 Ant. pol. : HORIZONTAL
 Limit : FCC PART 15 C (3M)
 Env. / Ins. : 24°C/65% Engineer : Even_Deng
 EUT : Universal Multi-Charging Station
 Power rating : DC 5V From Adapter Input AC 120V/60Hz
 Test Mode : Tx Mode
 M/N:CR13

No.	Freq. (MHz)	Ant. Factor (dB/m)	Cable Loss (dB)	Reading (dBuV)	Emission Level (dBuV/m)	Limits (dBuV/m)	Margin (dB)	Remark
1	34.850	17.13	0.92	6.07	24.12	40.00	15.88	QP
2	136.700	12.36	1.55	3.17	17.08	43.50	26.42	QP
3	173.560	9.77	1.69	8.19	19.65	43.50	23.85	QP
4	282.200	13.24	2.10	7.56	22.90	46.00	23.10	QP
5	377.260	15.65	2.39	5.04	23.08	46.00	22.92	QP
6	917.550	23.25	3.98	4.35	31.58	46.00	14.42	QP

Remarks: 1. Emission Level= Antenna Factor + Cable Loss + Reading.
 2. The emission levels that are 20dB below the official limit are not reported.

Frequency: 1GHz~18GHz

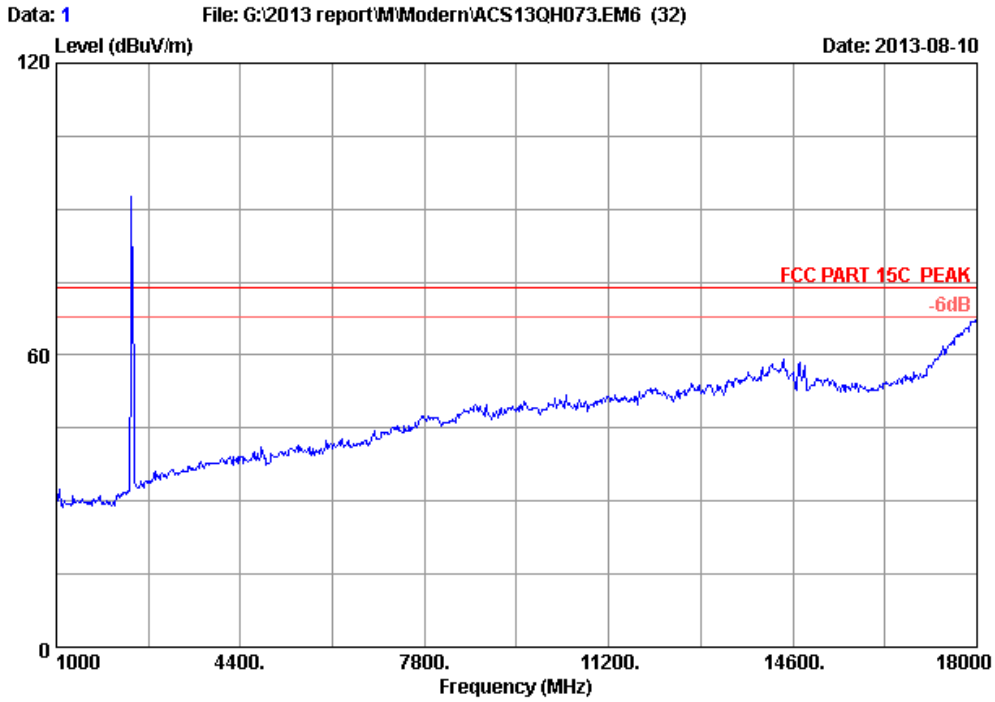

Site no. : 3m Chamber Data no. : 1
Dis. / Ant. : 3m 2012 3115 (4580) Ant. pol. : HORIZONTAL
Limit : FCC PART 15C PEAK
Env. / Ins. : 23*C/54% Engineer : Leo-Li
EUT : Universal Multi-Charging Station
Power supply : DC 5V From Adapter Input AC 120V/60Hz
Test mode : GFSK 2402MHz Tx
M/N : CR13
:

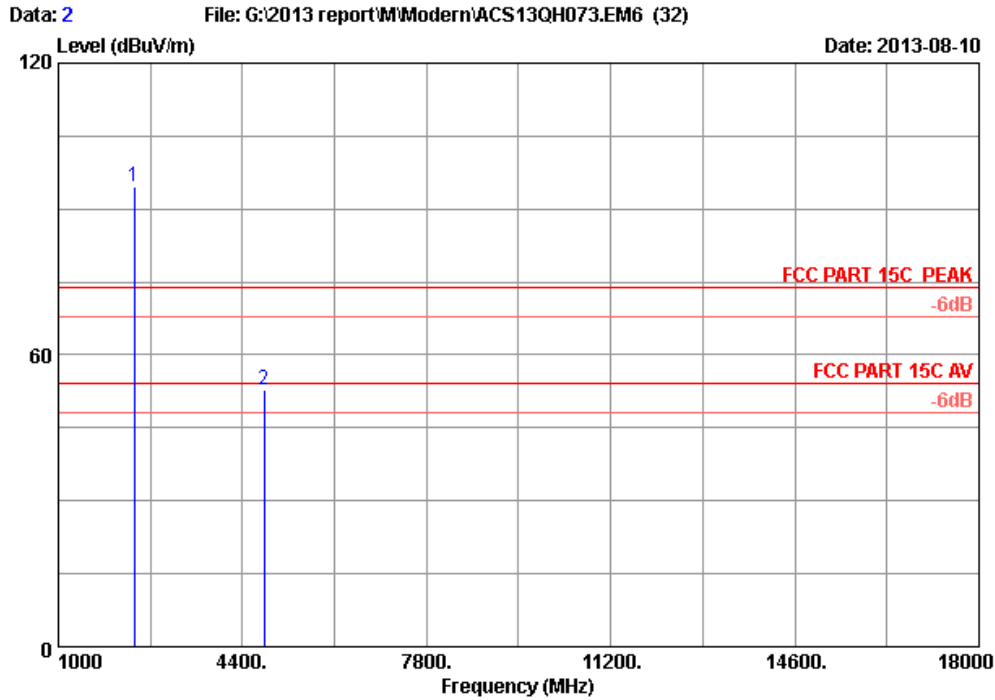

Site no. : 3m Chamber Data no. : 2
 Dis. / Ant. : 3m 2012 3115 (4580) Ant. pol. : HORIZONTAL
 Limit : FCC PART 15C PEAK
 Env. / Ins. : 23*C/54% Engineer : Leo-Li
 EUT : Universal Multi-Charging Station
 Power supply : DC 5V From Adapter Input AC 120V/60Hz
 Test mode : GFSK 2402MHz Tx
 M/N : CR13
 :

	Freq. (MHz)	Ant. Factor (dB/m)	Cable loss (dB)	Amp. Factor (dB)	Reading (dBuV)	Emission Level (dBuV/m)	Limits (dBuV/m)	Margin (dB)	Remark
1	2402.000	26.77	5.80	35.70	97.56	94.43	74.00	-20.43	Peak
2	4804.000	32.47	8.56	35.70	47.49	52.82	74.00	21.18	Peak

Remarks:

1. Emission Level= Antenna Factor + Cable Loss -Amp Factor + Reading.
2. The emission levels that are 20dB below the official limit are not reported.

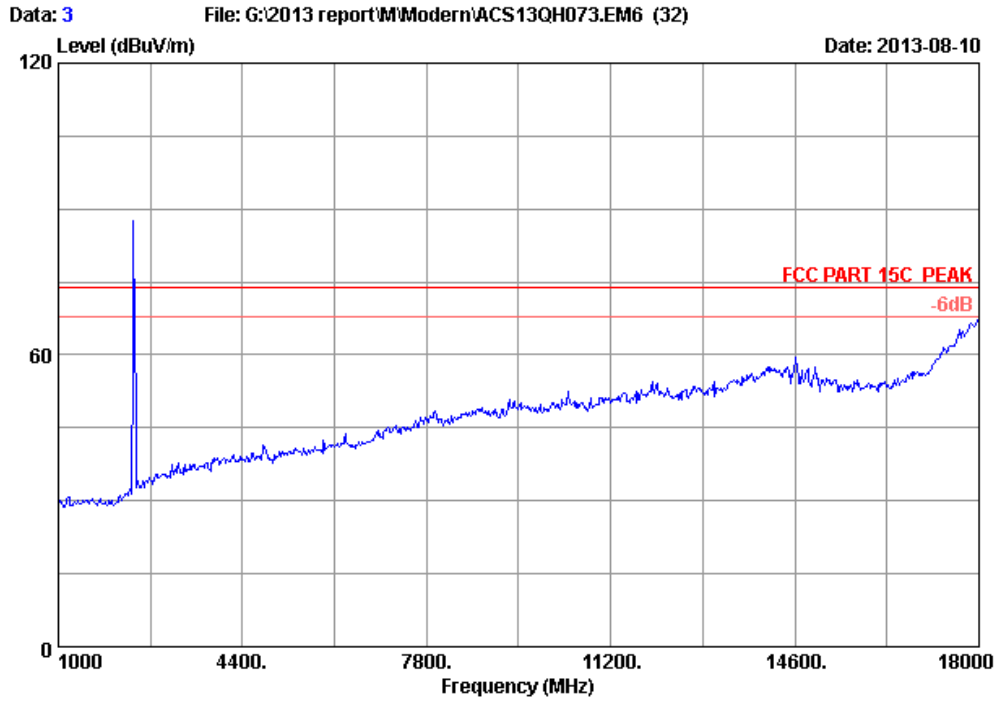

Site no. : 3m Chamber Data no. : 3
Dis. / Ant. : 3m 2012 3115 (4580) Ant. pol. : VERTICAL
Limit : FCC PART 15C PEAK
Env. / Ins. : 23*C/54% Engineer : Leo-Li
EUT : Universal Multi-Charging Station
Power supply : DC 5V From Adapter Input AC 120V/60Hz
Test mode : GFSK 2402MHz Tx
M/N : CR13
:

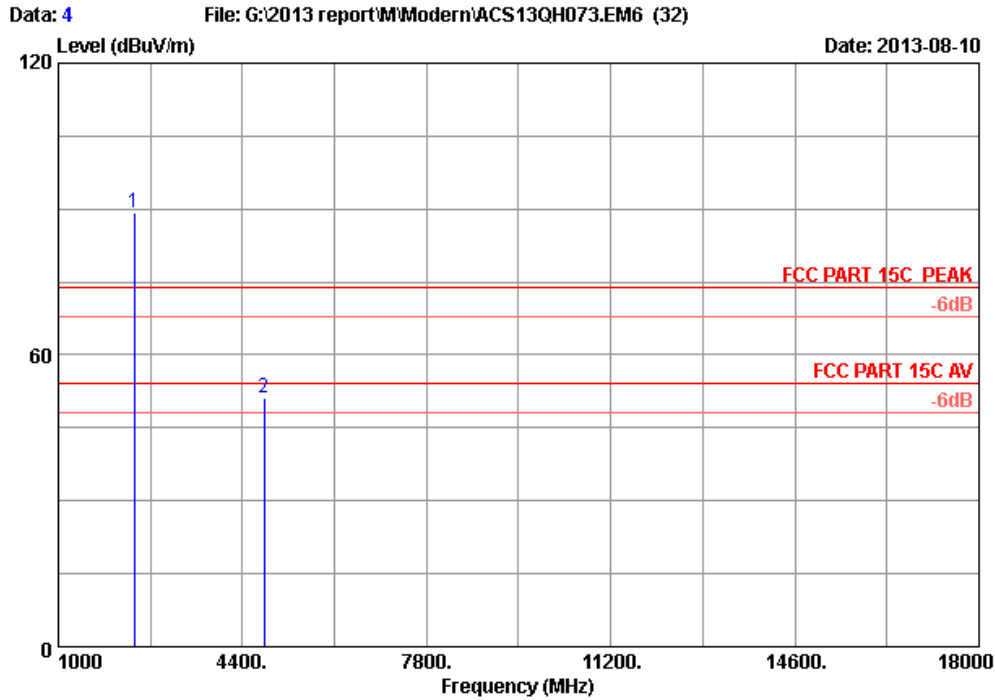

Site no. : 3m Chamber Data no. : 4
 Dis. / Ant. : 3m 2012 3115 (4580) Ant. pol. : VERTICAL
 Limit : FCC PART 15C PEAK
 Env. / Ins. : 23°C/54% Engineer : Leo-Li
 EUT : Universal Multi-Charging Station
 Power supply : DC 5V From Adapter Input AC 120V/60Hz
 Test mode : GFSK 2402MHz Tx
 M/N : CR13
 :

	Freq. (MHz)	Ant. Factor (dB/m)	Cable loss (dB)	Amp. Factor (dB)	Reading (dBuV)	Emission Level (dBuV/m)	Limits (dBuV/m)	Margin (dB)	Remark
1	2402.000	26.77	5.80	35.70	92.42	89.29	74.00	-15.29	Peak
2	4804.000	32.47	8.56	35.70	45.98	51.31	74.00	22.69	Peak

Remarks:

1. Emission Level= Antenna Factor + Cable Loss -Amp Factor + Reading.
2. The emission levels that are 20dB below the official limit are not reported.

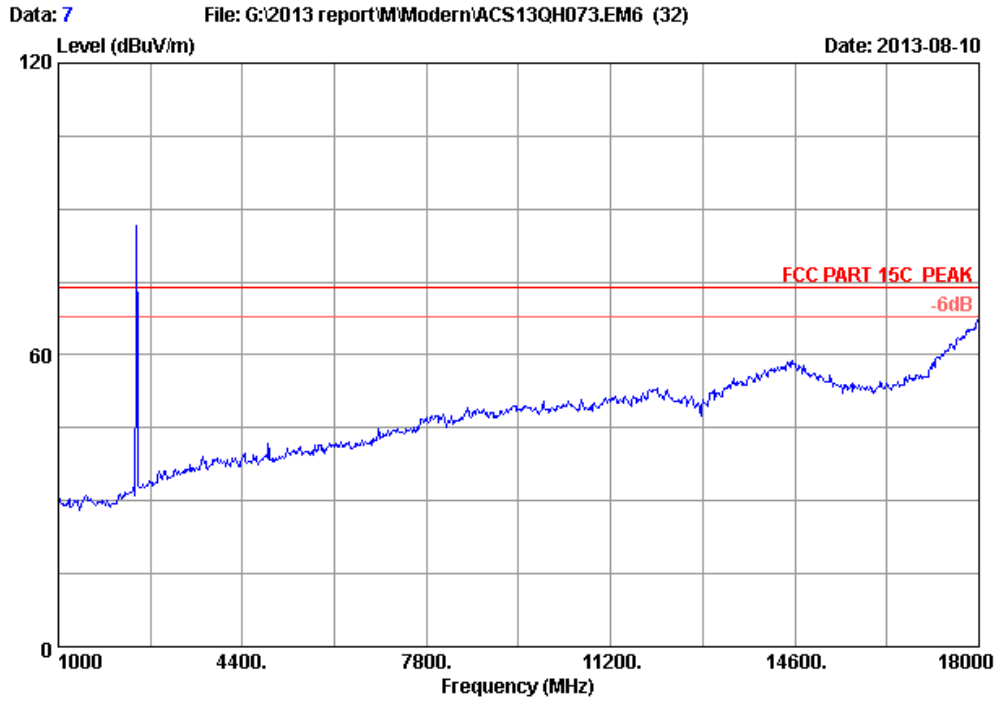

Site no. : 3m Chamber Data no. : 7
Dis. / Ant. : 3m 2012 3115 (4580) Ant. pol. : VERTICAL
Limit : FCC PART 15C PEAK
Env. / Ins. : 23*C/54% Engineer : Leo-Li
EUT : Universal Multi-Charging Station
Power supply : DC 5V From Adapter Input AC 120V/60Hz
Test mode : GFSK 2441MHz Tx
M/N : CR13
:

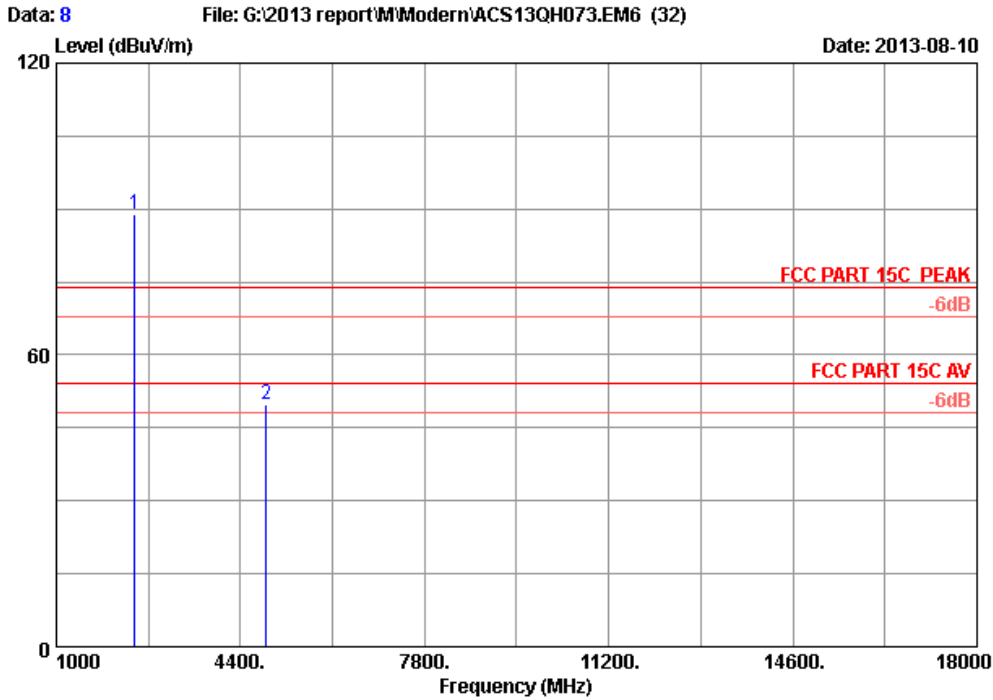

Site no. : 3m Chamber Data no. : 8
 Dis. / Ant. : 3m 2012 3115 (4580) Ant. pol. : VERTICAL
 Limit : FCC PART 15C PEAK
 Env. / Ins. : 23°C/54% Engineer : Leo-Li
 EUT : Universal Multi-Charging Station
 Power supply : DC 5V From Adapter Input AC 120V/60Hz
 Test mode : GFSK 2441MHz Tx
 M/N : CR13
 :

	Freq. (MHz)	Ant. Factor (dB/m)	Cable loss (dB)	Amp. Factor (dB)	Reading (dBuV)	Emission Level (dBuV/m)	Limits (dBuV/m)	Margin (dB)	Remark
1	2441.000	27.02	5.86	35.70	91.61	88.79	74.00	-14.79	Peak
2	4882.000	32.64	8.64	35.70	44.23	49.81	74.00	24.19	Peak

Remarks:

1. Emission Level= Antenna Factor + Cable Loss -Amp Factor + Reading.
2. The emission levels that are 20dB below the official limit are not reported.

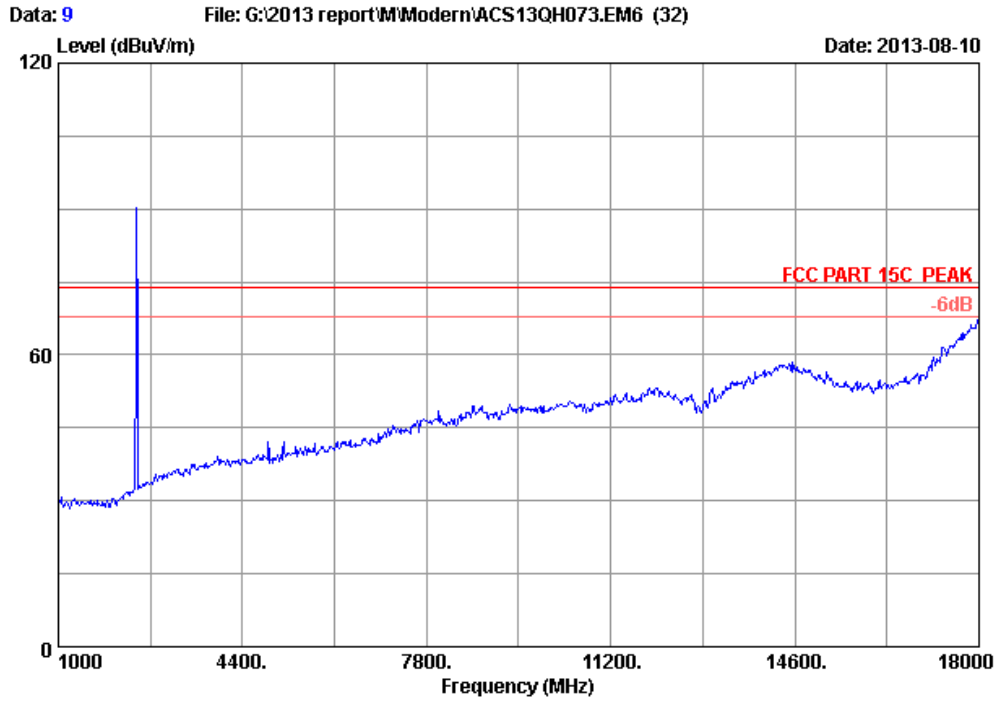

Site no. : 3m Chamber Data no. : 9
Dis. / Ant. : 3m 2012 3115 (4580) Ant. pol. : HORIZONTAL
Limit : FCC PART 15C PEAK
Env. / Ins. : 23*C/54% Engineer : Leo-Li
EUT : Universal Multi-Charging Station
Power supply : DC 5V From Adapter Input AC 120V/60Hz
Test mode : GFSK 2441MHz Tx
M/N : CR13
:

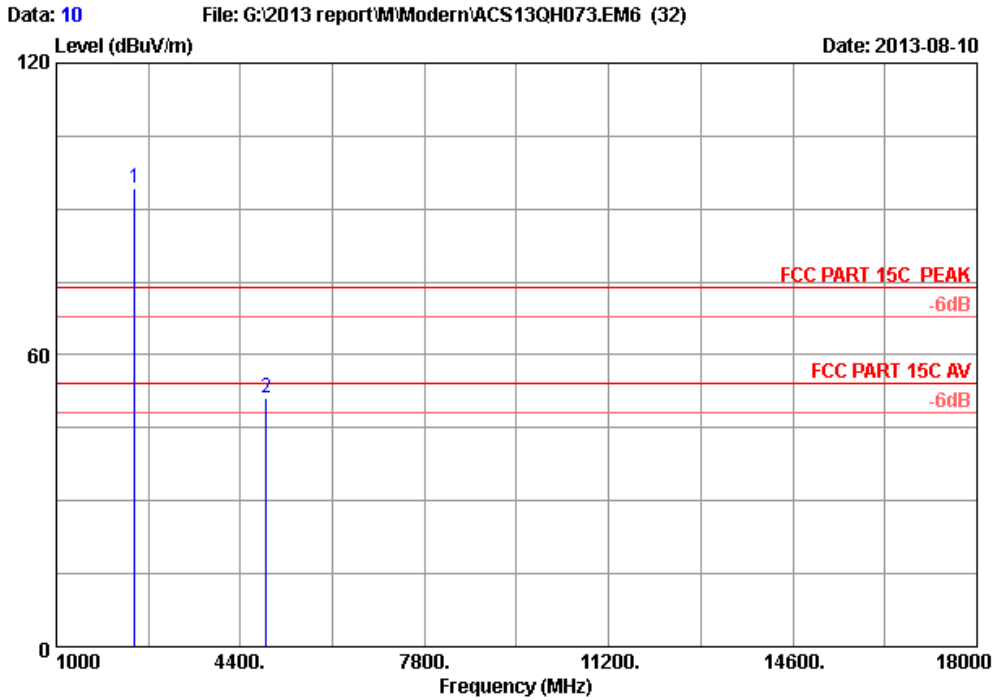

Site no. : 3m Chamber Data no. : 10
 Dis. / Ant. : 3m 2012 3115 (4580) Ant. pol. : HORIZONTAL
 Limit : FCC PART 15C PEAK
 Env. / Ins. : 23°C/54% Engineer : Leo-Li
 EUT : Universal Multi-Charging Station
 Power supply : DC 5V From Adapter Input AC 120V/60Hz
 Test mode : GFSK 2441MHz Tx
 M/N : CR13
 :

	Freq. (MHz)	Ant. Factor (dB/m)	Cable loss (dB)	Amp. Factor (dB)	Reading (dBuV)	Emission Level (dBuV/m)	Limits (dBuV/m)	Margin (dB)	Remark
1	2441.000	27.02	5.86	35.70	97.00	94.18	74.00	-20.18	Peak
2	4882.000	32.64	8.64	35.70	45.64	51.22	74.00	22.78	Peak

Remarks:

1. Emission Level= Antenna Factor + Cable Loss -Amp Factor + Reading.
2. The emission levels that are 20dB below the official limit are not reported.

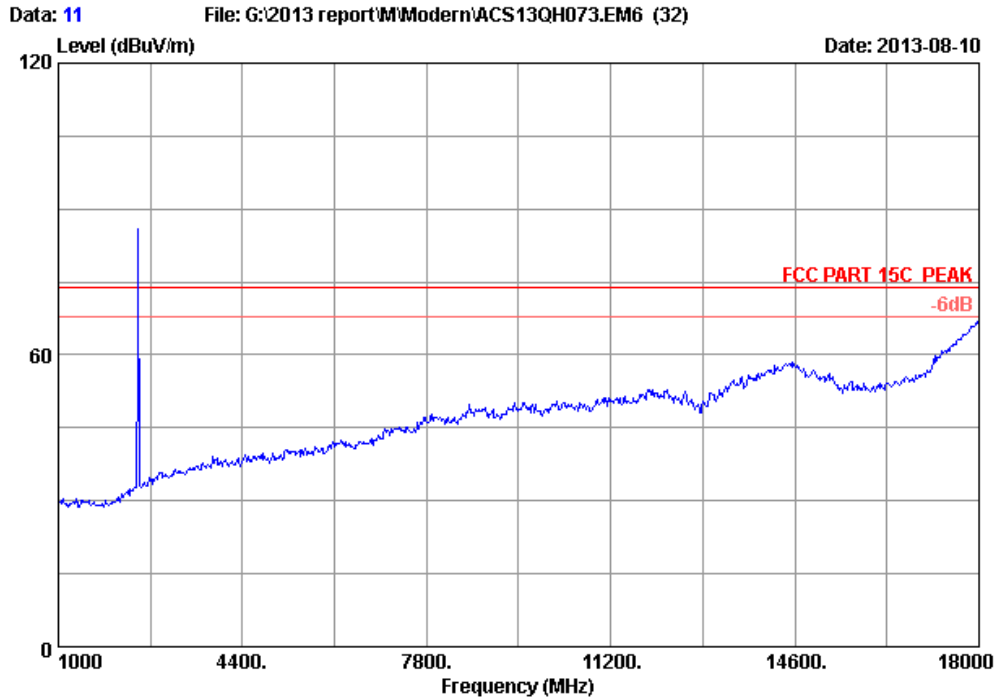

Site no. : 3m Chamber Data no. : 11
Dis. / Ant. : 3m 2012 3115 (4580) Ant. pol. : VERTICAL
Limit : FCC PART 15C PEAK
Env. / Ins. : 23*C/54% Engineer : Leo-Li
EUT : Universal Multi-Charging Station
Power supply : DC 5V From Adapter Input AC 120V/60Hz
Test mode : GFSK 2480MHz Tx
M/N : CR13
:

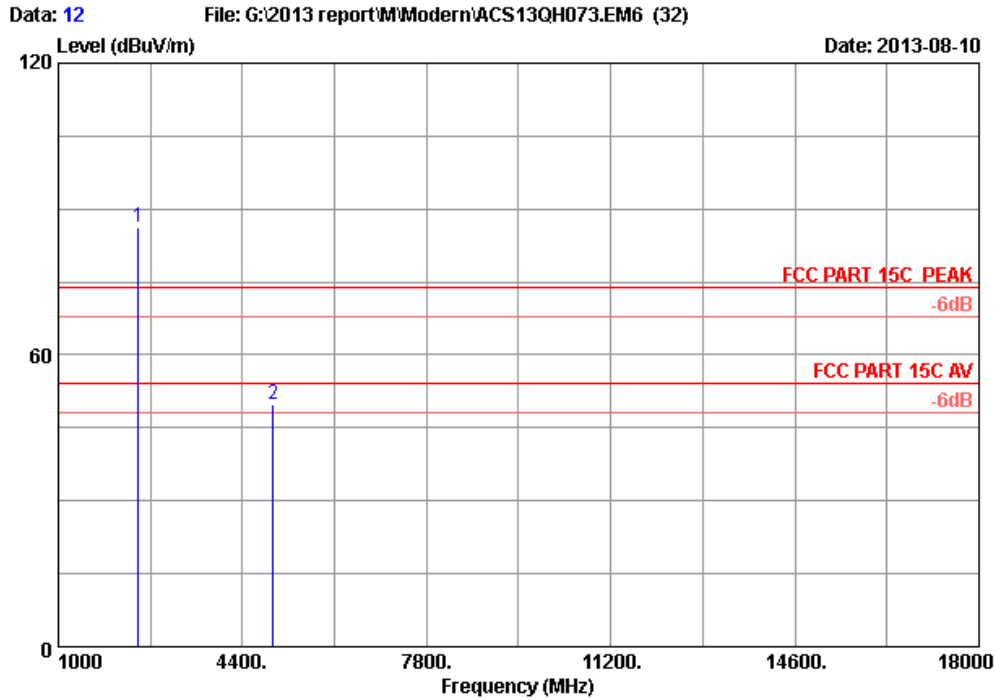

Site no. : 3m Chamber Data no. : 12
 Dis. / Ant. : 3m 2012 3115 (4580) Ant. pol. : VERTICAL
 Limit : FCC PART 15C PEAK
 Env. / Ins. : 23°C/54% Engineer : Leo-Li
 EUT : Universal Multi-Charging Station
 Power supply : DC 5V From Adapter Input AC 120V/60Hz
 Test mode : GFSK 2480MHz Tx
 M/N : CR13
 :

	Freq. (MHz)	Ant. Factor (dB/m)	Cable loss (dB)	Amp. Factor (dB)	Reading (dBuV)	Emission Level (dBuV/m)	Limits (dBuV/m)	Margin (dB)	Remark
1	2480.000	27.27	5.91	35.70	88.81	86.29	74.00	-12.29	Peak
2	4960.000	32.81	8.72	35.70	44.00	49.83	74.00	24.17	Peak

Remarks:

1. Emission Level= Antenna Factor + Cable Loss -Amp Factor + Reading.
2. The emission levels that are 20dB below the official limit are not reported.

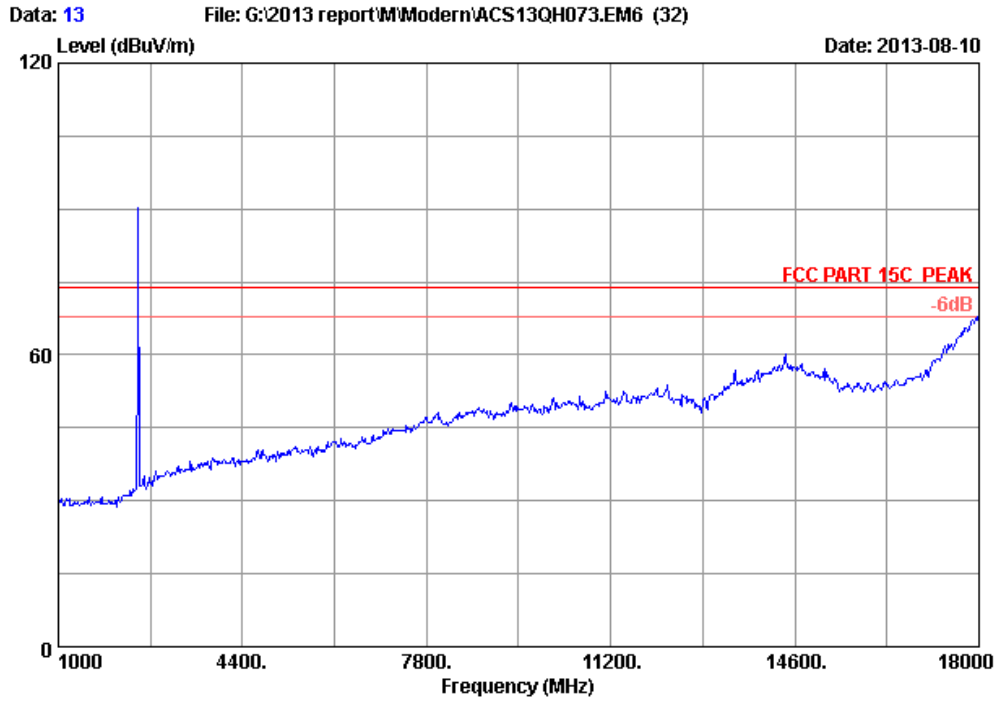

Site no. : 3m Chamber Data no. : 13
Dis. / Ant. : 3m 2012 3115 (4580) Ant. pol. : HORIZONTAL
Limit : FCC PART 15C PEAK
Env. / Ins. : 23*C/54% Engineer : Leo-Li
EUT : Universal Multi-Charging Station
Power supply : DC 5V From Adapter Input AC 120V/60Hz
Test mode : GFSK 2480MHz Tx
M/N : CR13
:

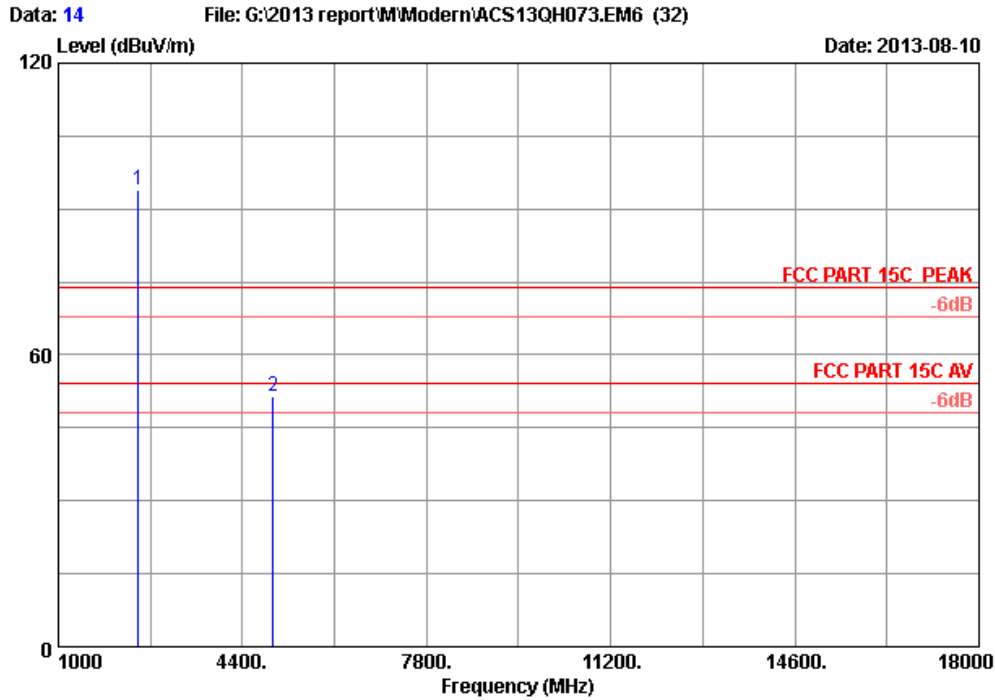

Site no. : 3m Chamber Data no. : 14
 Dis. / Ant. : 3m 2012 3115 (4580) Ant. pol. : HORIZONTAL
 Limit : FCC PART 15C PEAK
 Env. / Ins. : 23*C/54% Engineer : Leo-Li
 EUT : Universal Multi-Charging Station
 Power supply : DC 5V From Adapter Input AC 120V/60Hz
 Test mode : GFSK 2480MHz Tx
 M/N : CR13
 :

	Freq. (MHz)	Ant. Factor (dB/m)	Cable loss (dB)	Amp. Factor (dB)	Reading (dBuV)	Emission Level (dBuV/m)	Limits (dBuV/m)	Margin (dB)	Remark
1	2480.000	27.27	5.91	35.70	96.53	94.01	74.00	-20.01	Peak
2	4960.000	32.81	8.72	35.70	45.72	51.55	74.00	22.45	Peak

Remarks:

1. Emission Level= Antenna Factor + Cable Loss -Amp Factor + Reading.
2. The emission levels that are 20dB below the official limit are not reported.

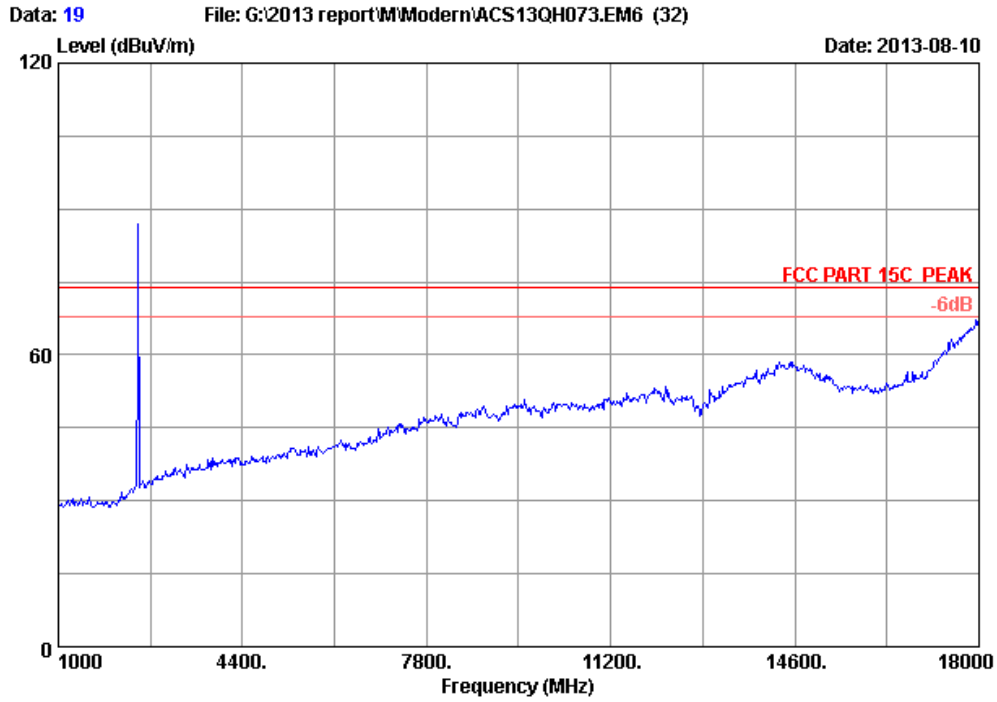

Site no. : 3m Chamber Data no. : 19
Dis. / Ant. : 3m 2012 3115 (4580) Ant. pol. : VERTICAL
Limit : FCC PART 15C PEAK
Env. / Ins. : 23*C/54% Engineer : Leo-Li
EUT : Universal Multi-Charging Station
Power supply : DC 5V From Adapter Input AC 120V/60Hz
Test mode : 8DPSK 2480MHz Tx
M/N : CR13
:

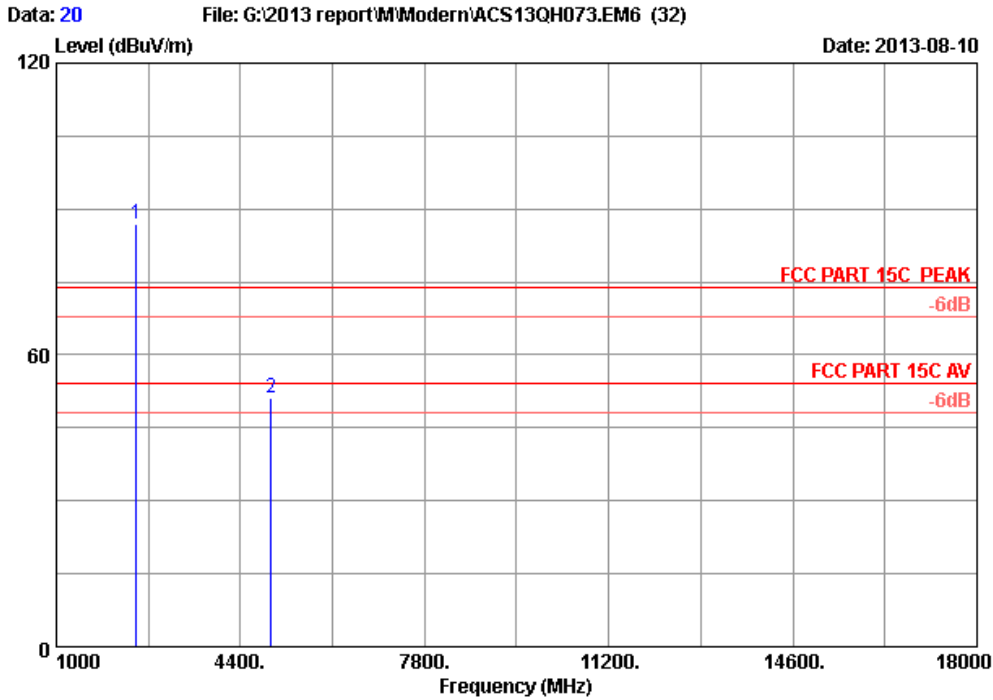

Site no. : 3m Chamber Data no. : 20
 Dis. / Ant. : 3m 2012 3115 (4580) Ant. pol. : VERTICAL
 Limit : FCC PART 15C PEAK
 Env. / Ins. : 23°C/54% Engineer : Leo-Li
 EUT : Universal Multi-Charging Station
 Power supply : DC 5V From Adapter Input AC 120V/60Hz
 Test mode : 8DPSK 2480MHz Tx
 M/N : CR13
 :

	Freq. (MHz)	Ant. Factor (dB/m)	Cable loss (dB)	Amp. Factor (dB)	Reading (dBuV)	Emission Level (dBuV/m)	Limits (dBuV/m)	Margin (dB)	Remark
1	2480.000	27.27	5.91	35.70	89.34	86.82	74.00	-12.82	Peak
2	4960.000	32.81	8.72	35.70	45.43	51.26	74.00	22.74	Peak

Remarks:

1. Emission Level= Antenna Factor + Cable Loss -Amp Factor + Reading.
2. The emission levels that are 20dB below the official limit are not reported.

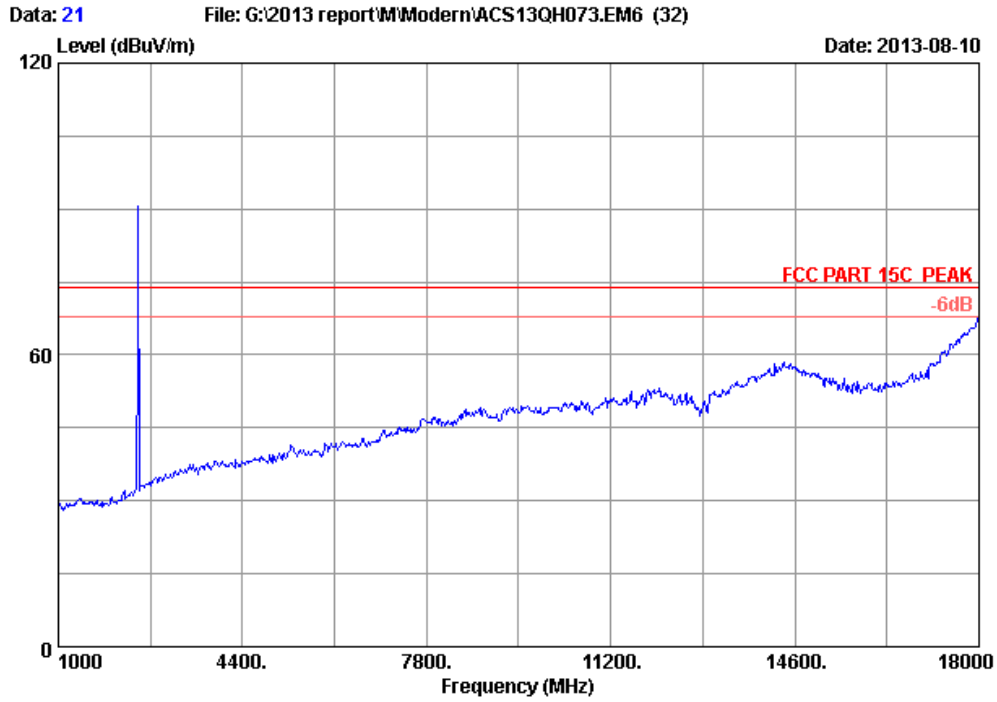

Site no. : 3m Chamber Data no. : 21
Dis. / Ant. : 3m 2012 3115 (4580) Ant. pol. : HORIZONTAL
Limit : FCC PART 15C PEAK
Env. / Ins. : 23*C/54% Engineer : Leo-Li
EUT : Universal Multi-Charging Station
Power supply : DC 5V From Adapter Input AC 120V/60Hz
Test mode : 8DPSK 2480MHz Tx
M/N : CR13
:

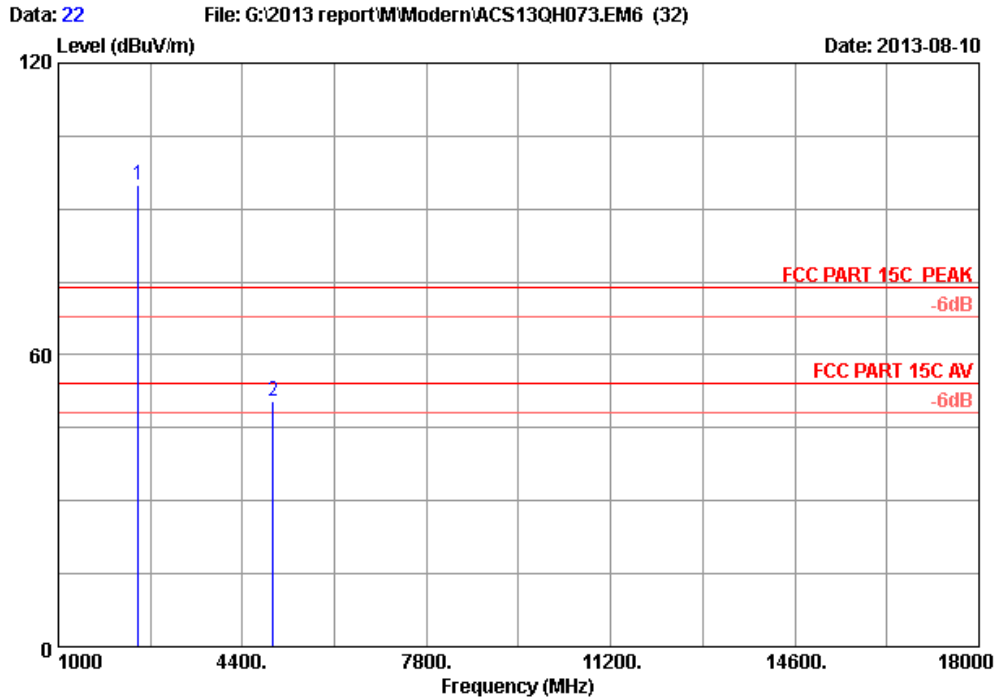

Site no. : 3m Chamber Data no. : 22
 Dis. / Ant. : 3m 2012 3115 (4580) Ant. pol. : HORIZONTAL
 Limit : FCC PART 15C PEAK
 Env. / Ins. : 23*C/54% Engineer : Leo-Li
 EUT : Universal Multi-Charging Station
 Power supply : DC 5V From Adapter Input AC 120V/60Hz
 Test mode : 8DPSK 2480MHz Tx
 M/N : CR13
 :

	Freq. (MHz)	Ant. Factor (dB/m)	Cable loss (dB)	Amp. Factor (dB)	Reading (dBuV)	Emission Level (dBuV/m)	Limits (dBuV/m)	Margin (dB)	Remark
1	2480.000	27.27	5.91	35.70	97.35	94.83	74.00	-20.83	Peak
2	4960.000	32.81	8.72	35.70	44.72	50.55	74.00	23.45	Peak

Remarks:

1. Emission Level= Antenna Factor + Cable Loss -Amp Factor + Reading.
2. The emission levels that are 20dB below the official limit are not reported.

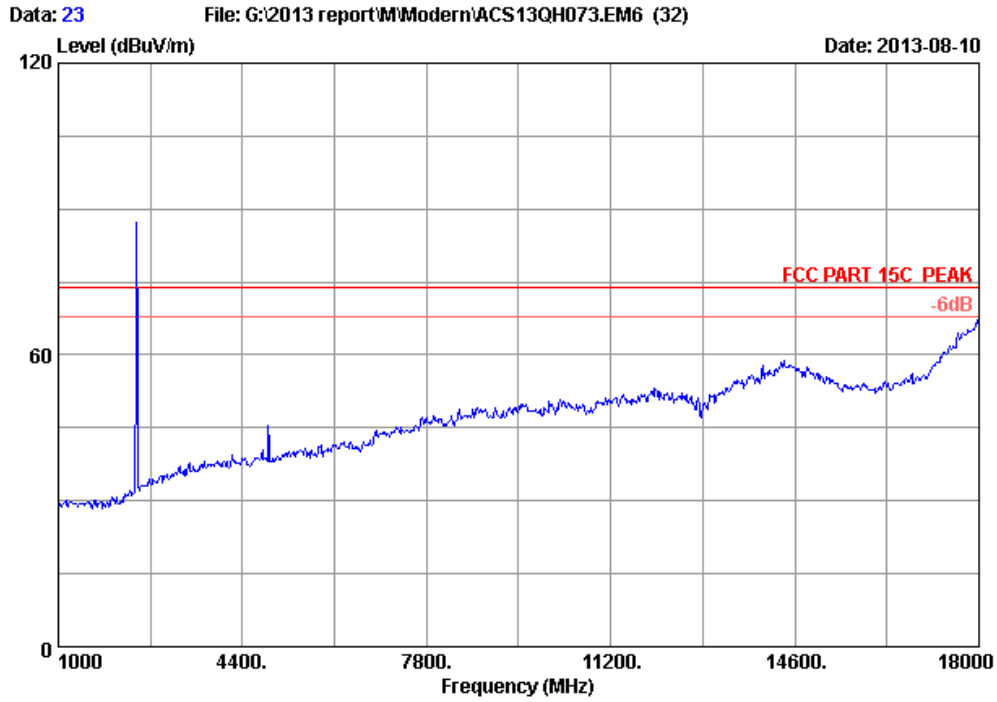

Site no. : 3m Chamber Data no. : 23
Dis. / Ant. : 3m 2012 3115 (4580) Ant. pol. : VERTICAL
Limit : FCC PART 15C PEAK
Env. / Ins. : 23*C/54% Engineer : Leo-Li
EUT : Universal Multi-Charging Station
Power supply : DC 5V From Adapter Input AC 120V/60Hz
Test mode : 8DPSK 2441MHz Tx
M/N : CR13
:

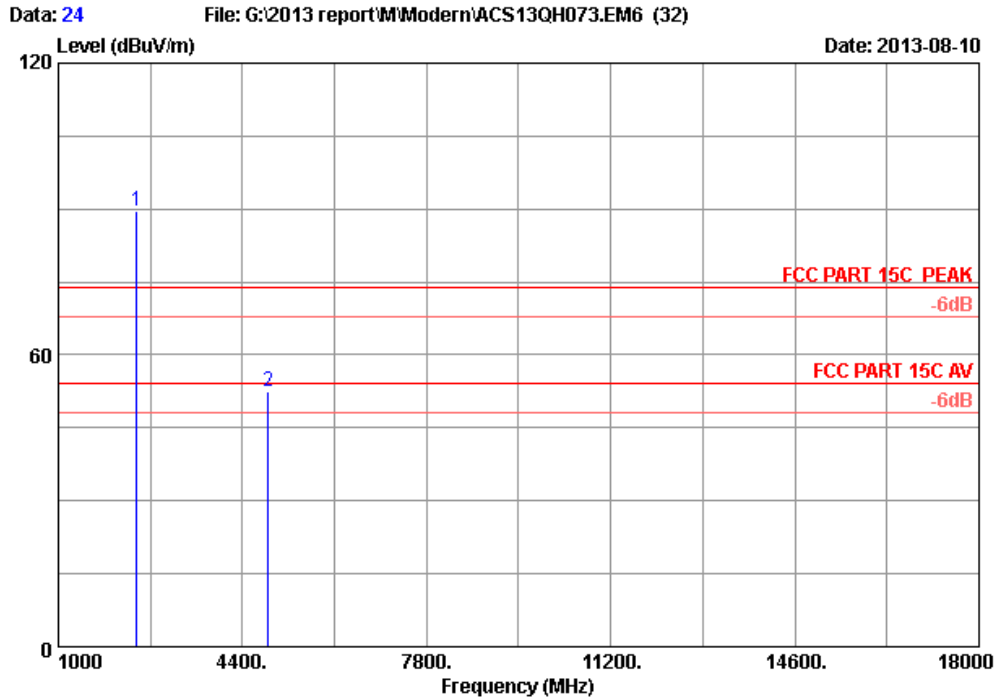

Site no. : 3m Chamber Data no. : 24
 Dis. / Ant. : 3m 2012 3115 (4580) Ant. pol. : VERTICAL
 Limit : FCC PART 15C PEAK
 Env. / Ins. : 23°C/54% Engineer : Leo-Li
 EUT : Universal Multi-Charging Station
 Power supply : DC 5V From Adapter Input AC 120V/60Hz
 Test mode : 8DPSK 2441MHz Tx
 M/N : CR13
 :

	Freq. (MHz)	Ant. Factor (dB/m)	Cable loss (dB)	Amp. Factor (dB)	Reading (dBuV)	Emission Level (dBuV/m)	Limits (dBuV/m)	Margin (dB)	Remark
1	2441.000	27.02	5.86	35.70	92.57	89.75	74.00	-15.75	Peak
2	4882.000	32.64	8.64	35.70	46.81	52.39	74.00	21.61	Peak

Remarks:

1. Emission Level= Antenna Factor + Cable Loss -Amp Factor + Reading.
2. The emission levels that are 20dB below the official limit are not reported.

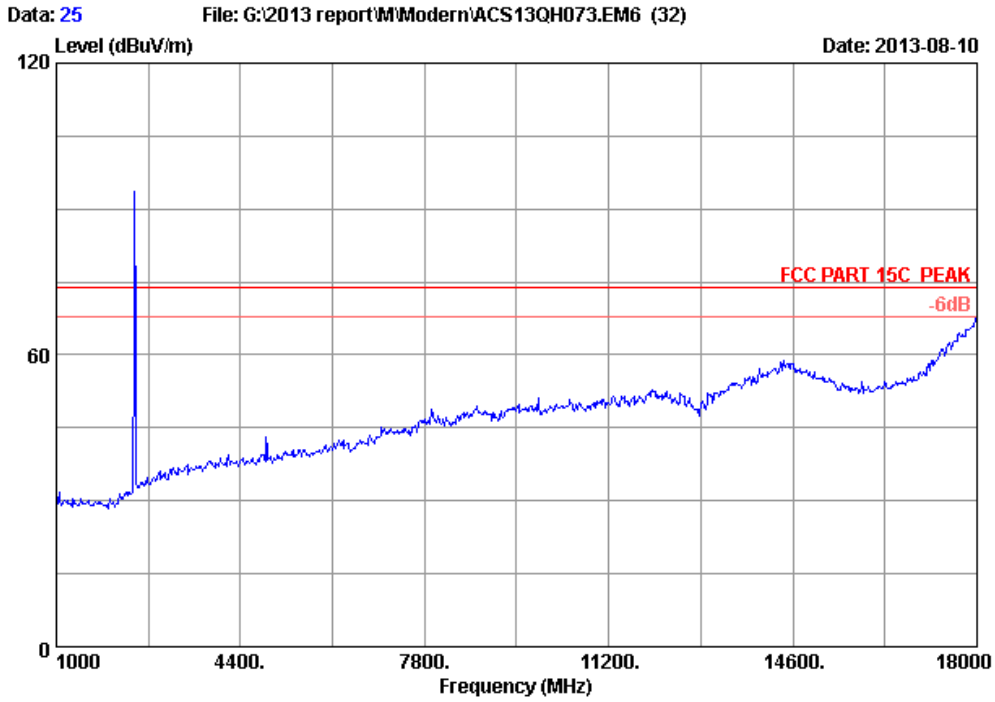

Site no. : 3m Chamber Data no. : 25
Dis. / Ant. : 3m 2012 3115 (4580) Ant. pol. : HORIZONTAL
Limit : FCC PART 15C PEAK
Env. / Ins. : 23*C/54% Engineer : Leo-Li
EUT : Universal Multi-Charging Station
Power supply : DC 5V From Adapter Input AC 120V/60Hz
Test mode : 8DPSK 2441MHz Tx
M/N : CR13
:

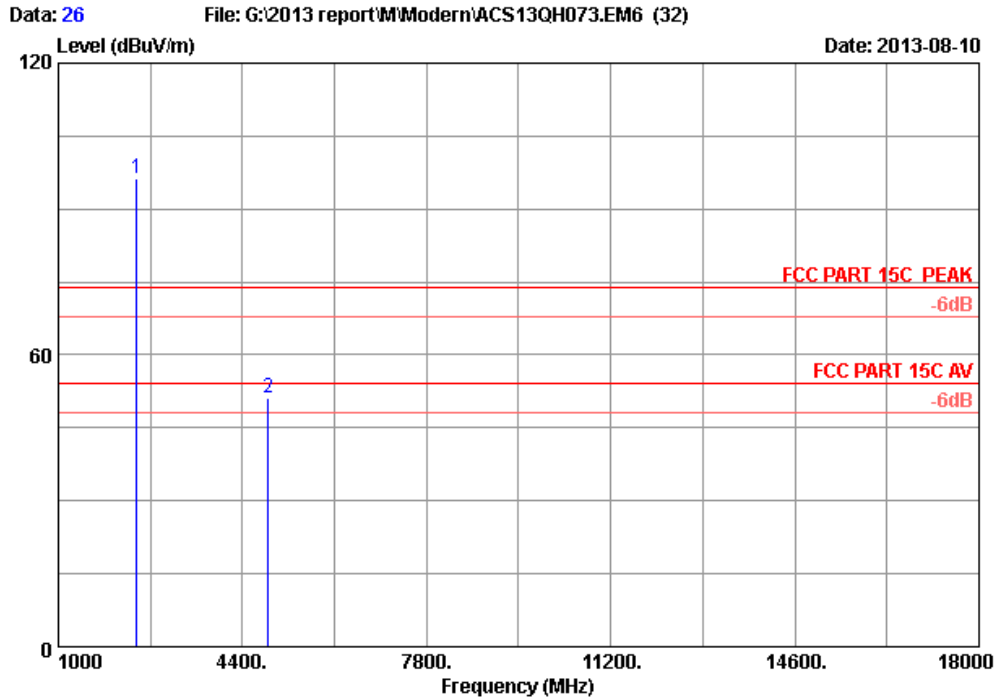

Site no. : 3m Chamber Data no. : 26
 Dis. / Ant. : 3m 2012 3115 (4580) Ant. pol. : HORIZONTAL
 Limit : FCC PART 15C PEAK
 Env. / Ins. : 23°C/54% Engineer : Leo-Li
 EUT : Universal Multi-Charging Station
 Power supply : DC 5V From Adapter Input AC 120V/60Hz
 Test mode : 8DPSK 2441MHz Tx
 M/N : CR13
 :

	Freq. (MHz)	Ant. Factor (dB/m)	Cable loss (dB)	Amp. Factor (dB)	Reading (dBuV)	Emission Level (dBuV/m)	Limits (dBuV/m)	Margin (dB)	Remark
1	2441.000	27.02	5.86	35.70	99.10	96.28	74.00	-22.28	Peak
2	4882.000	32.64	8.64	35.70	45.59	51.17	74.00	22.83	Peak

- Remarks:
1. Emission Level= Antenna Factor + Cable Loss -Amp Factor + Reading.
 2. The emission levels that are 20dB below the official limit are not reported.

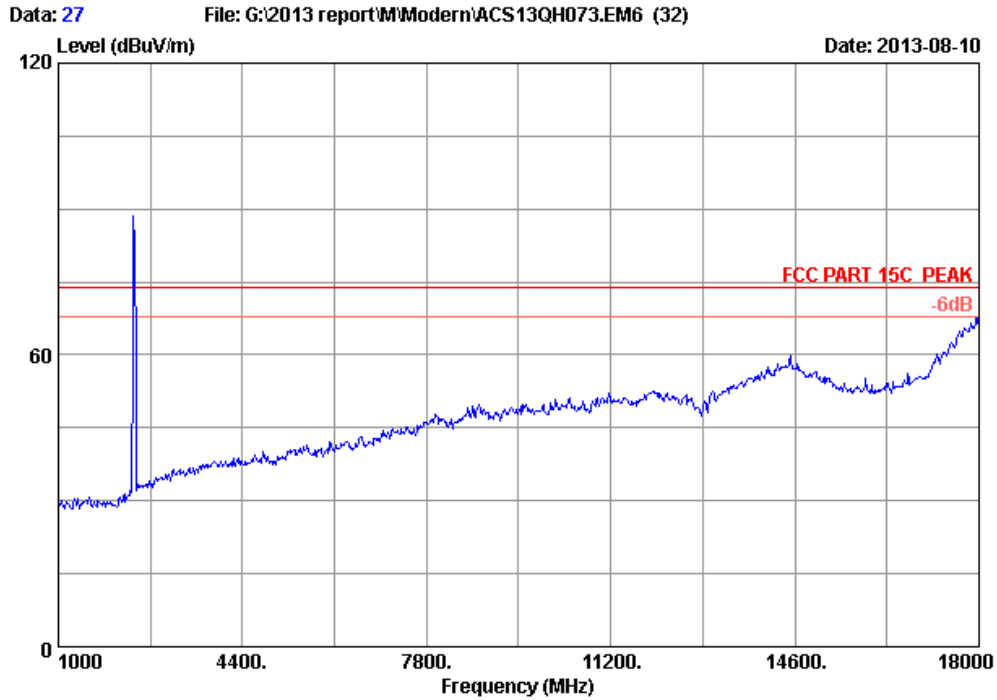

Site no. : 3m Chamber Data no. : 27
Dis. / Ant. : 3m 2012 3115 (4580) Ant. pol. : VERTICAL
Limit : FCC PART 15C PEAK
Env. / Ins. : 23*C/54% Engineer : Leo-Li
EUT : Universal Multi-Charging Station
Power supply : DC 5V From Adapter Input AC 120V/60Hz
Test mode : 8DPSK 2402MHz Tx
M/N : CR13
:

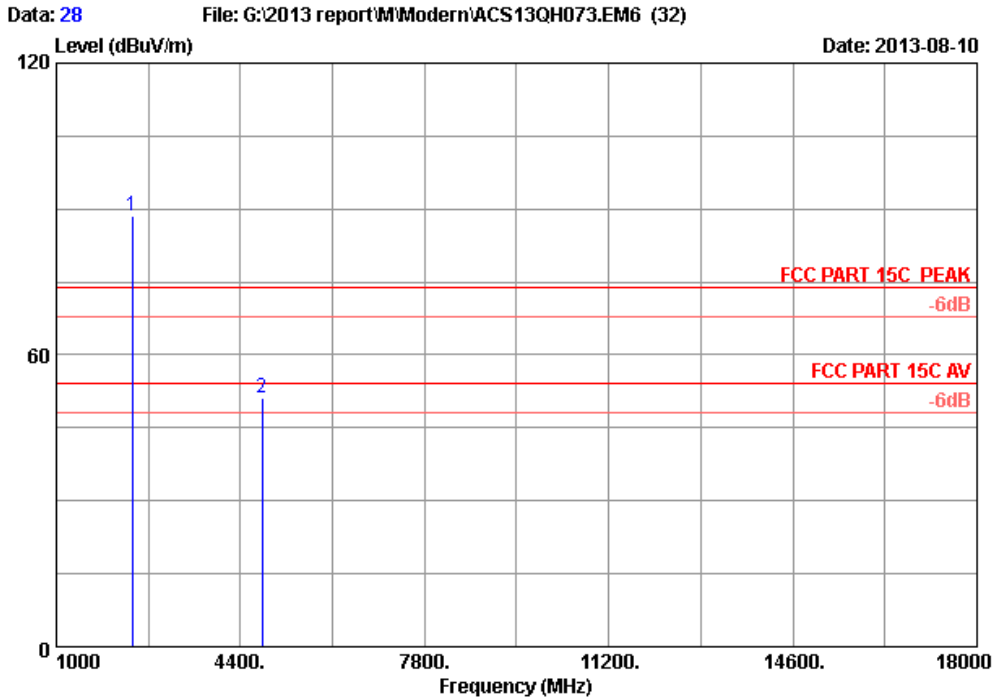

Site no. : 3m Chamber Data no. : 28
 Dis. / Ant. : 3m 2012 3115 (4580) Ant. pol. : VERTICAL
 Limit : FCC PART 15C PEAK
 Env. / Ins. : 23°C/54% Engineer : Leo-Li
 EUT : Universal Multi-Charging Station
 Power supply : DC 5V From Adapter Input AC 120V/60Hz
 Test mode : 8DPSK 2402MHz Tx
 M/N : CR13
 :

	Freq. (MHz)	Ant. Factor (dB/m)	Cable loss (dB)	Amp. Factor (dB)	Reading (dBuV)	Emission Level (dBuV/m)	Limits (dBuV/m)	Margin (dB)	Remark
1	2402.000	26.77	5.80	35.70	91.79	88.66	74.00	-14.66	Peak
2	4804.000	32.47	8.56	35.70	45.74	51.07	74.00	22.93	Peak

Remarks:

1. Emission Level= Antenna Factor + Cable Loss -Amp Factor + Reading.
2. The emission levels that are 20dB below the official limit are not reported.

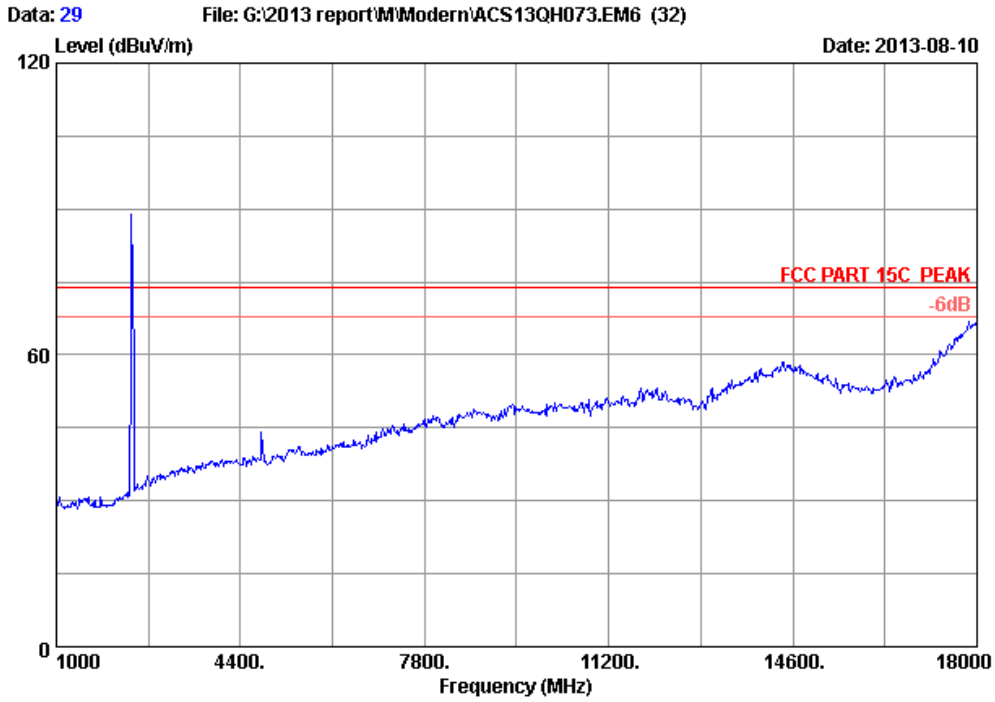

Site no. : 3m Chamber Data no. : 29
Dis. / Ant. : 3m 2012 3115 (4580) Ant. pol. : HORIZONTAL
Limit : FCC PART 15C PEAK
Env. / Ins. : 23*C/54% Engineer : Leo-Li
EUT : Universal Multi-Charging Station
Power supply : DC 5V From Adapter Input AC 120V/60Hz
Test mode : 8DPSK 2402MHz Tx
M/N : CR13
:

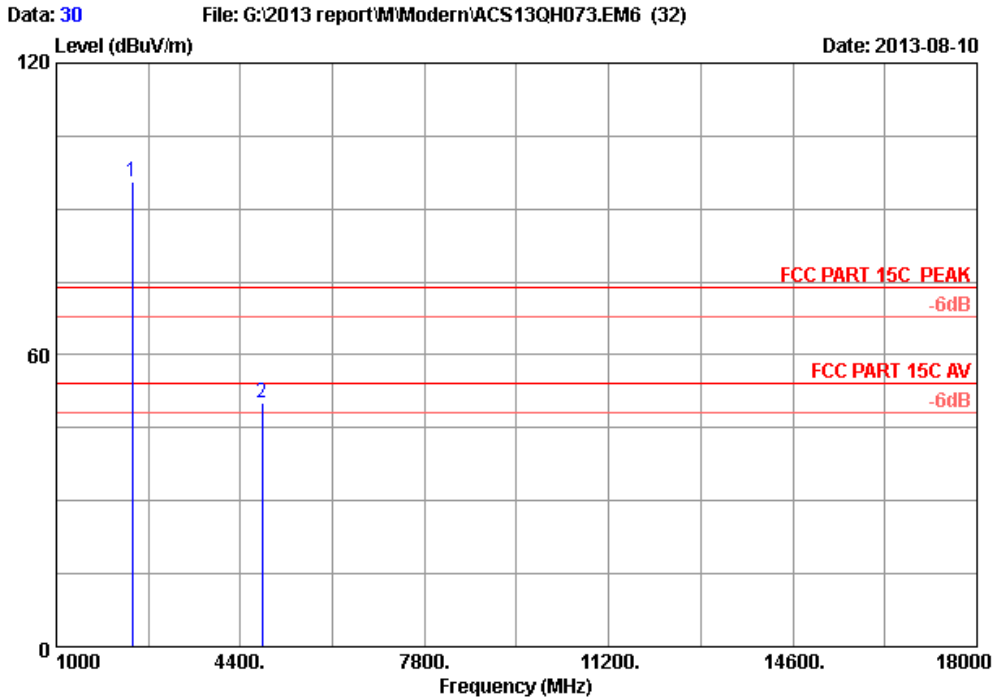

Site no. : 3m Chamber Data no. : 30
 Dis. / Ant. : 3m 2012 3115 (4580) Ant. pol. : HORIZONTAL
 Limit : FCC PART 15C PEAK
 Env. / Ins. : 23°C/54% Engineer : Leo-Li
 EUT : Universal Multi-Charging Station
 Power supply : DC 5V From Adapter Input AC 120V/60Hz
 Test mode : 8DPSK 2402MHz Tx
 M/N : CR13
 :

	Freq. (MHz)	Ant. Factor (dB/m)	Cable loss (dB)	Amp. Factor (dB)	Reading (dBuV)	Emission Level (dBuV/m)	Limits (dBuV/m)	Margin (dB)	Remark
1	2402.000	26.77	5.80	35.70	98.64	95.51	74.00	-21.51	Peak
2	4804.000	32.47	8.56	35.70	44.74	50.07	74.00	23.93	Peak

Remarks:

1. Emission Level= Antenna Factor + Cable Loss -Amp Factor + Reading.
2. The emission levels that are 20dB below the official limit are not reported.

5. CONDUCTED SPURIOUS EMISSIONS

5.1. Test Equipment

Item	Equipment	Manufacturer	Model No.	Serial No.	Last Cal.	Cal. Interval
1.	PXA Signal Analyzer	Agilent	N9030A	MY51380221	Oct.31, 12	1 Year
2.	Attenuator	Agilent	8491B	MY39262165	May.08,13	1 Year
3.	RF Cable	Hubersuhner	SUCOFLEX102	28618/2	May.08,13	1Year

5.2. Limit

In any 100kHz bandwidth outside the frequency bands in which the spread spectrum intentional radiator is operating, the radio frequency power that is produced by the intentional radiator shall be at least 20dB below that in the 100kHz bandwidth within the band that contains the highest level of the desired power.

5.3. Test Procedure

The transmitter output was connected to a spectrum analyzer, The resolution bandwidth is set to 100 kHz, The video bandwidth is set to 300 kHz and measure all the emissions detected.

5.4. Test result

PASS (The testing data was attached in the next pages.)

There is no obvious emission in the range 9KHz~30MHz, so the emission result was not record in the report. All emission in the range 9KHz~30MHz are at least 20dB below limit; So the emission plot was not reported in the report.

**Hopping On
GFSK
2402MHz**

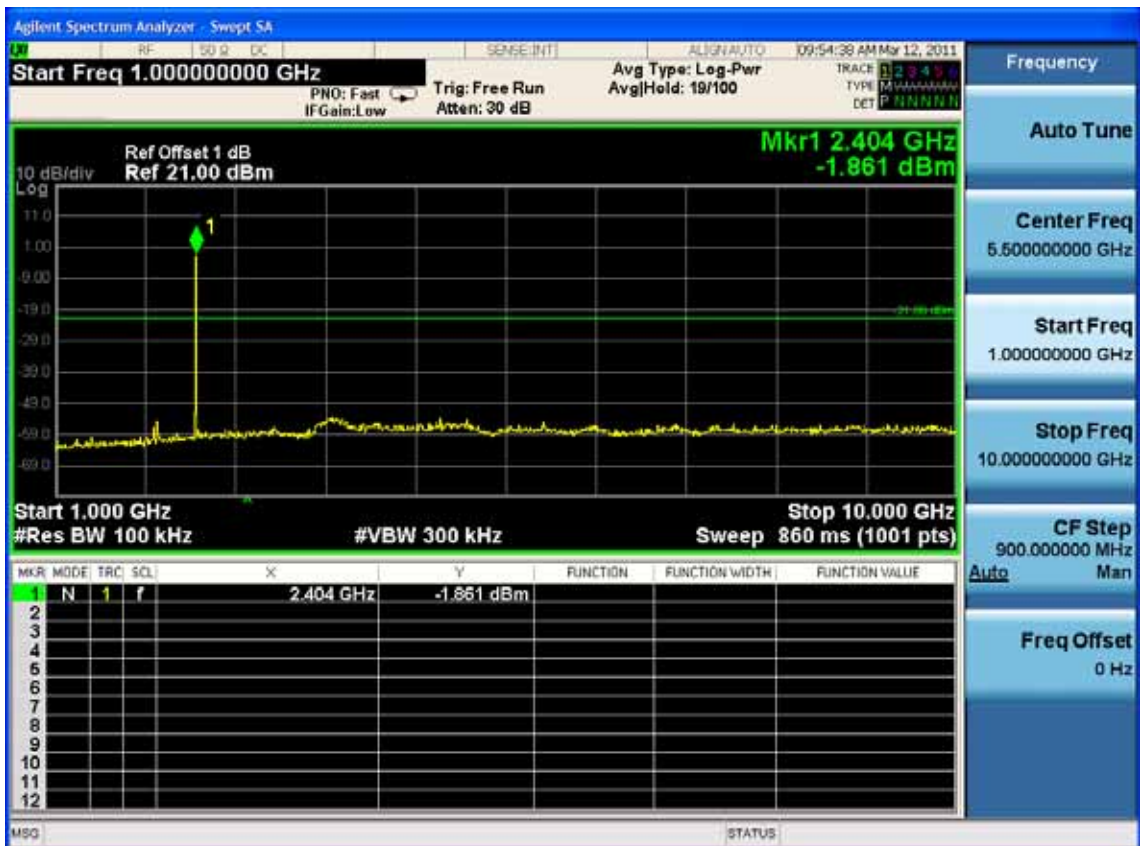
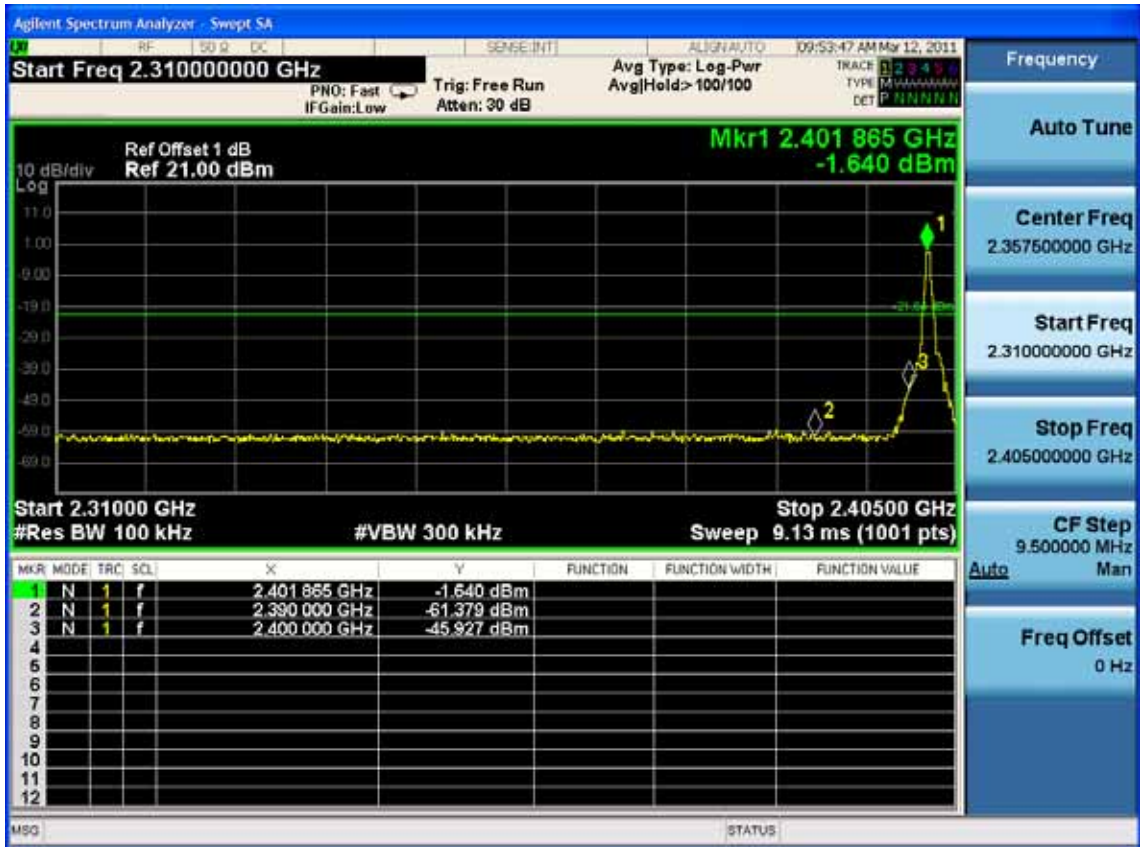

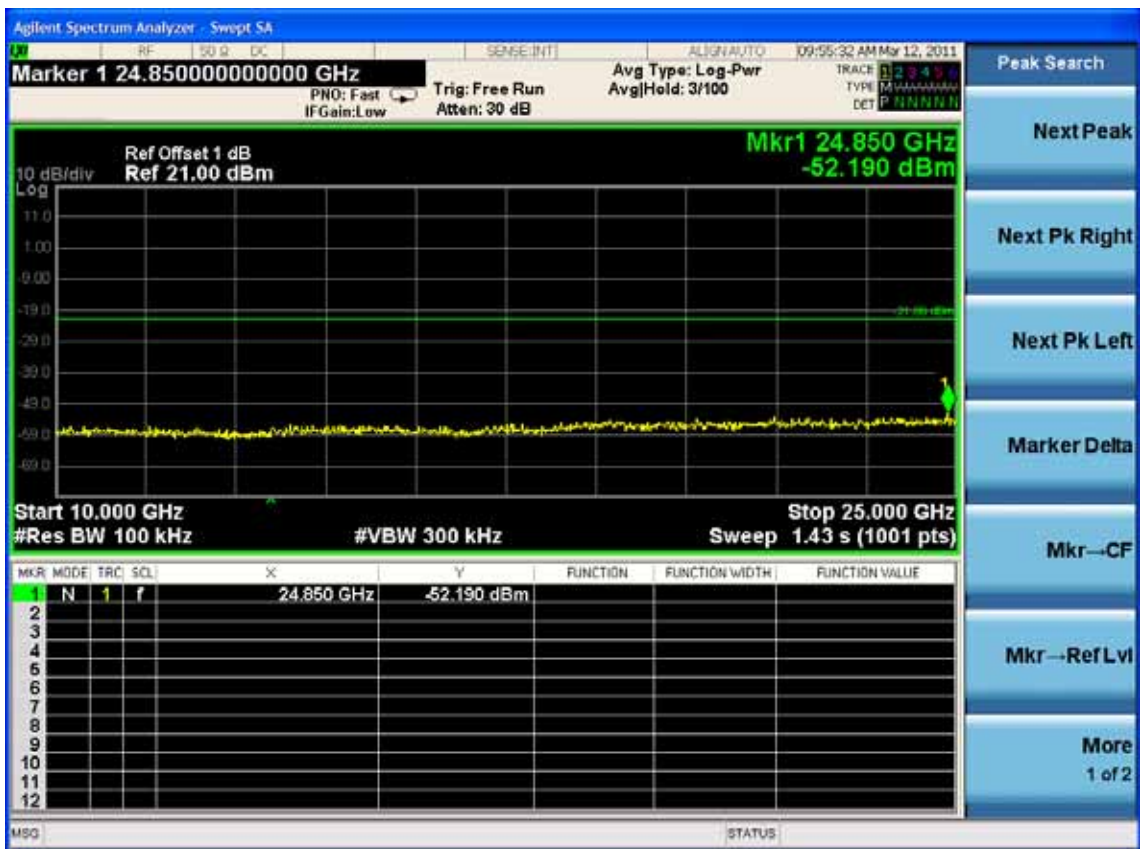
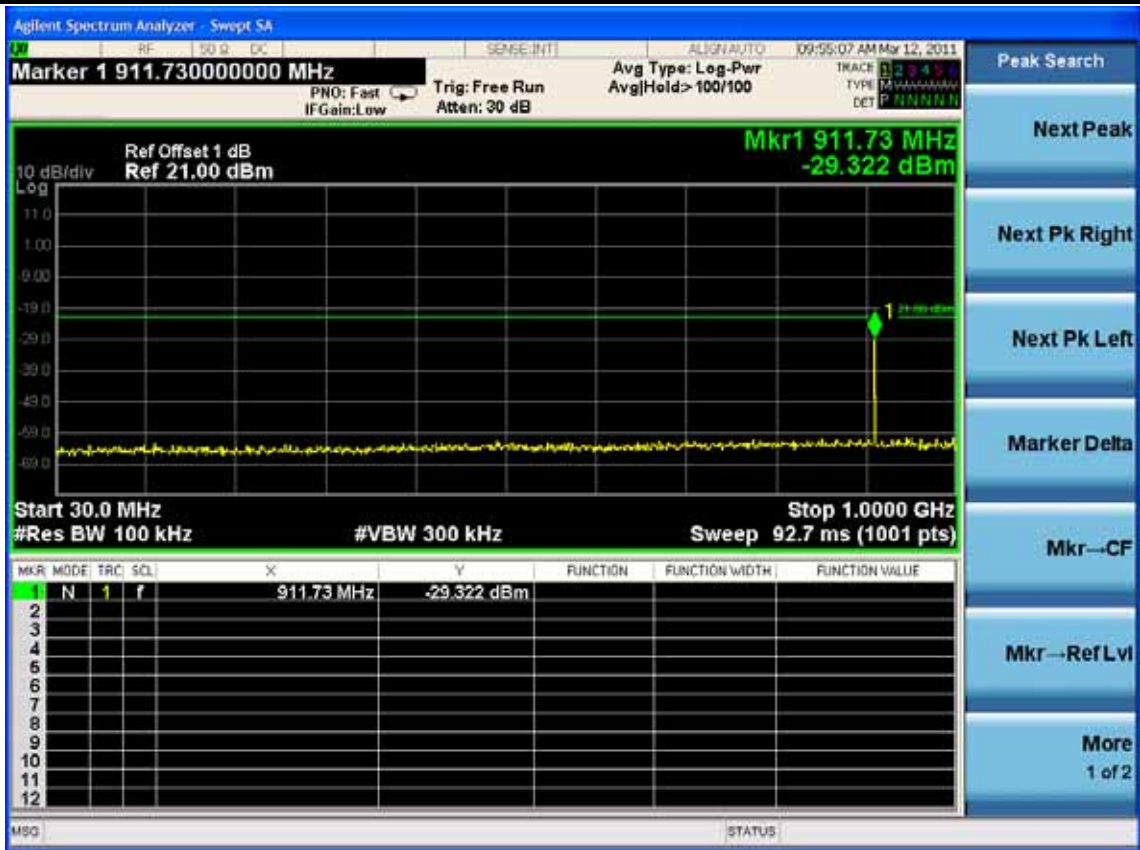

2441MHz

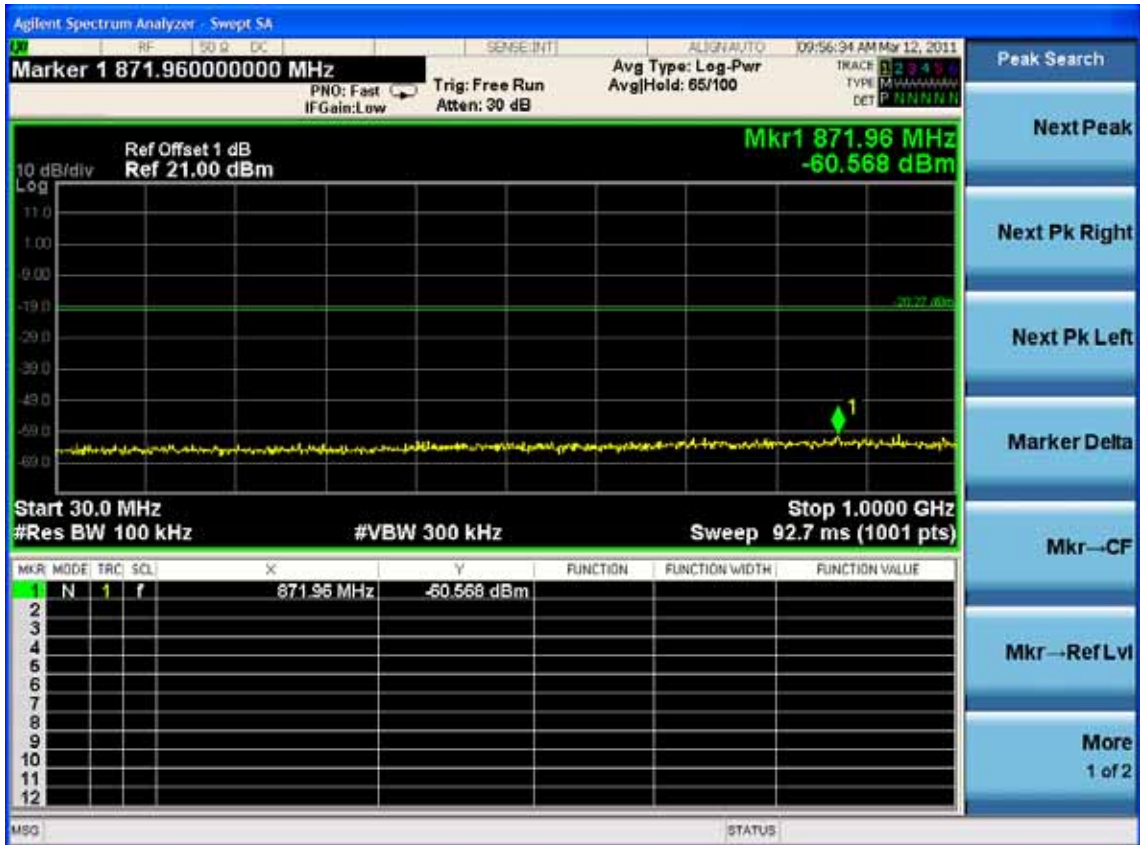
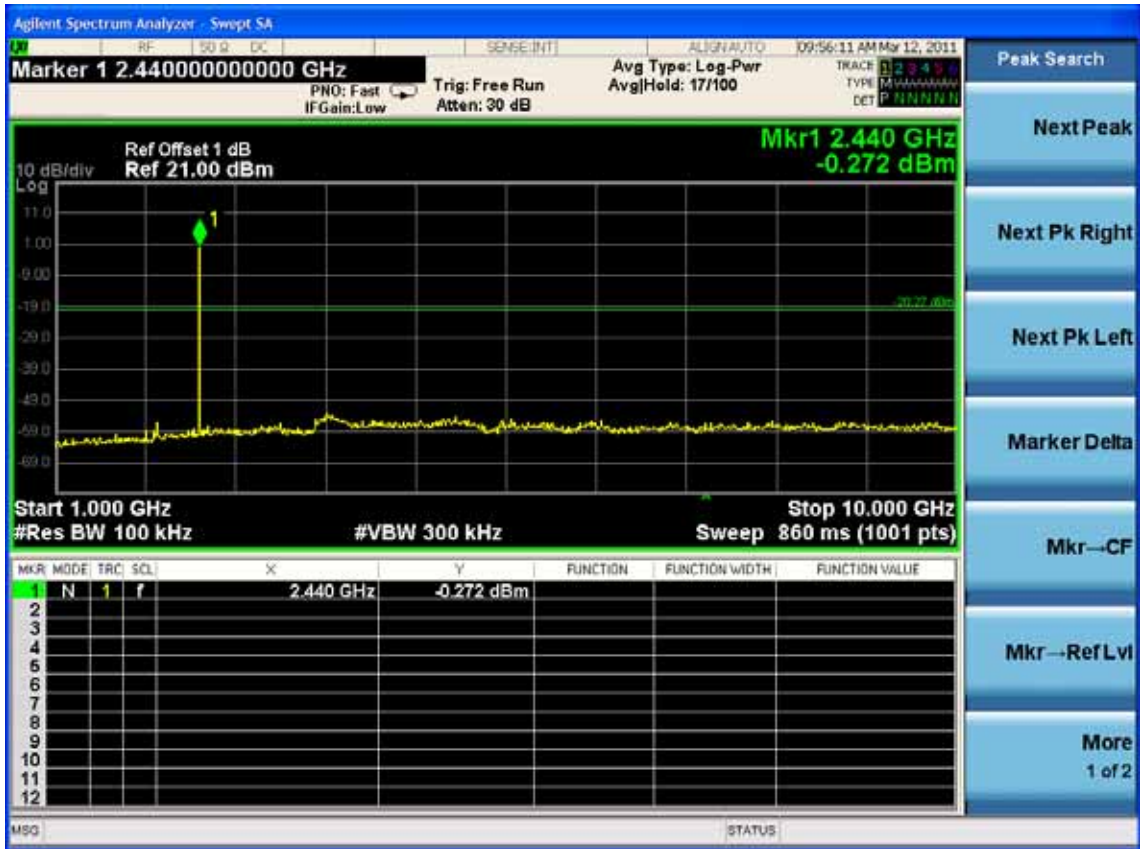

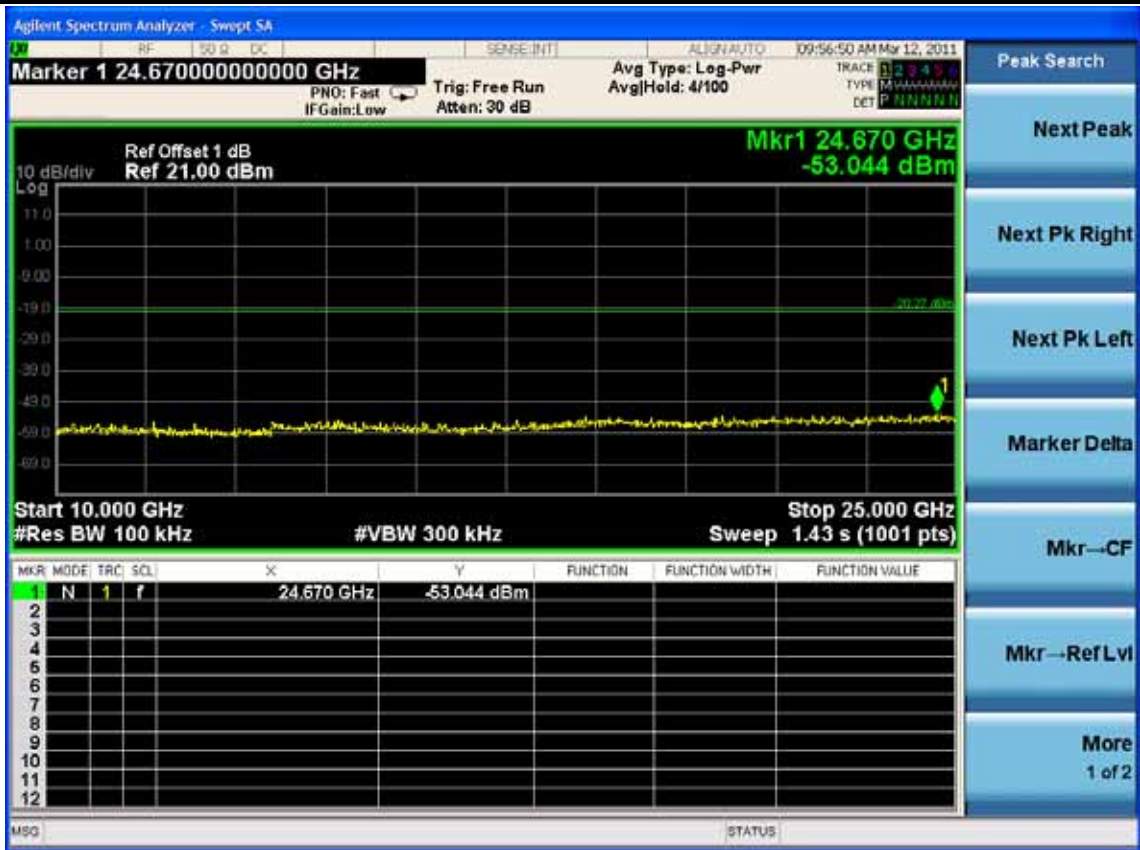

2480MHz

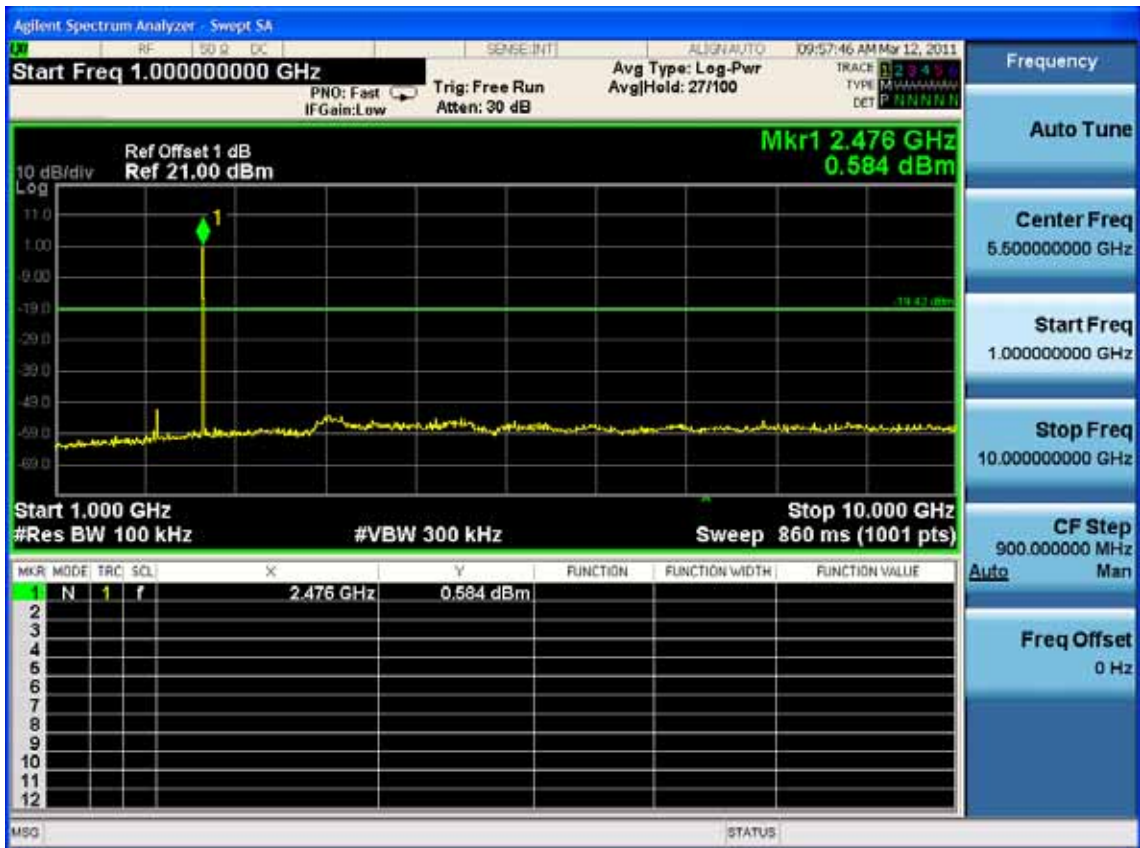

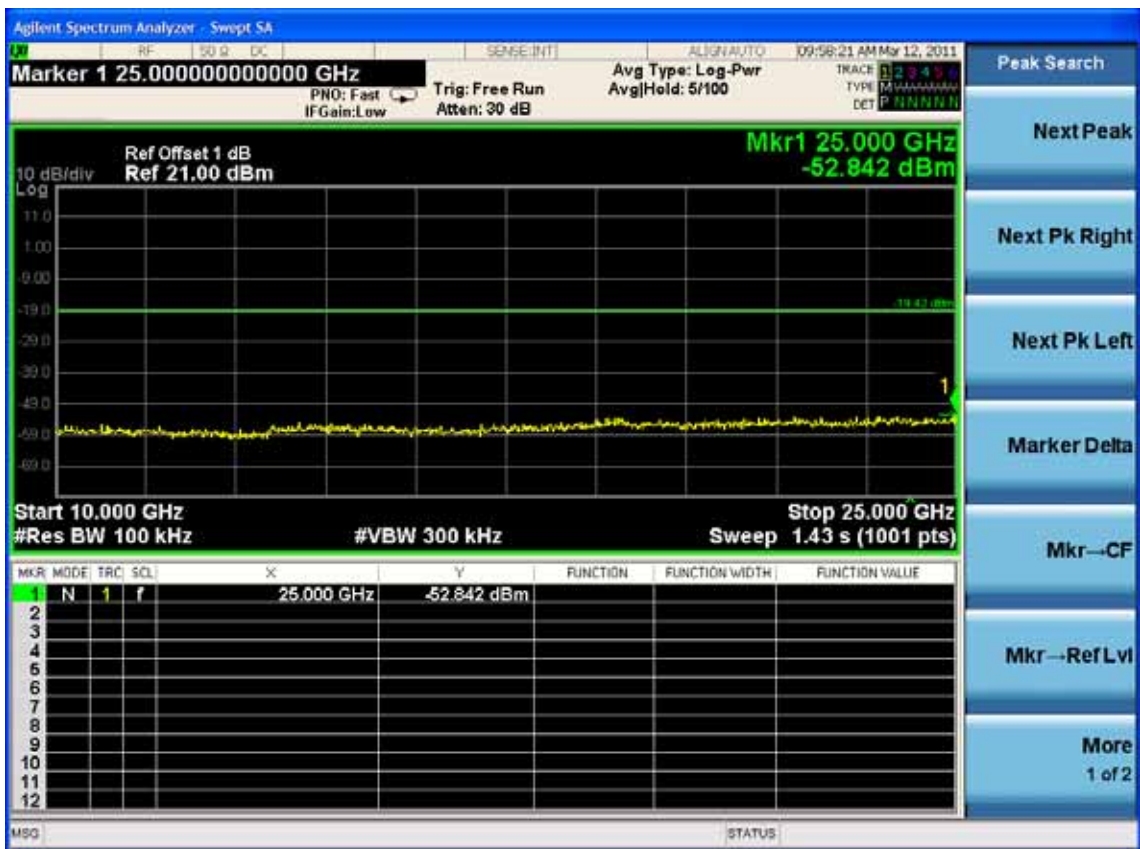
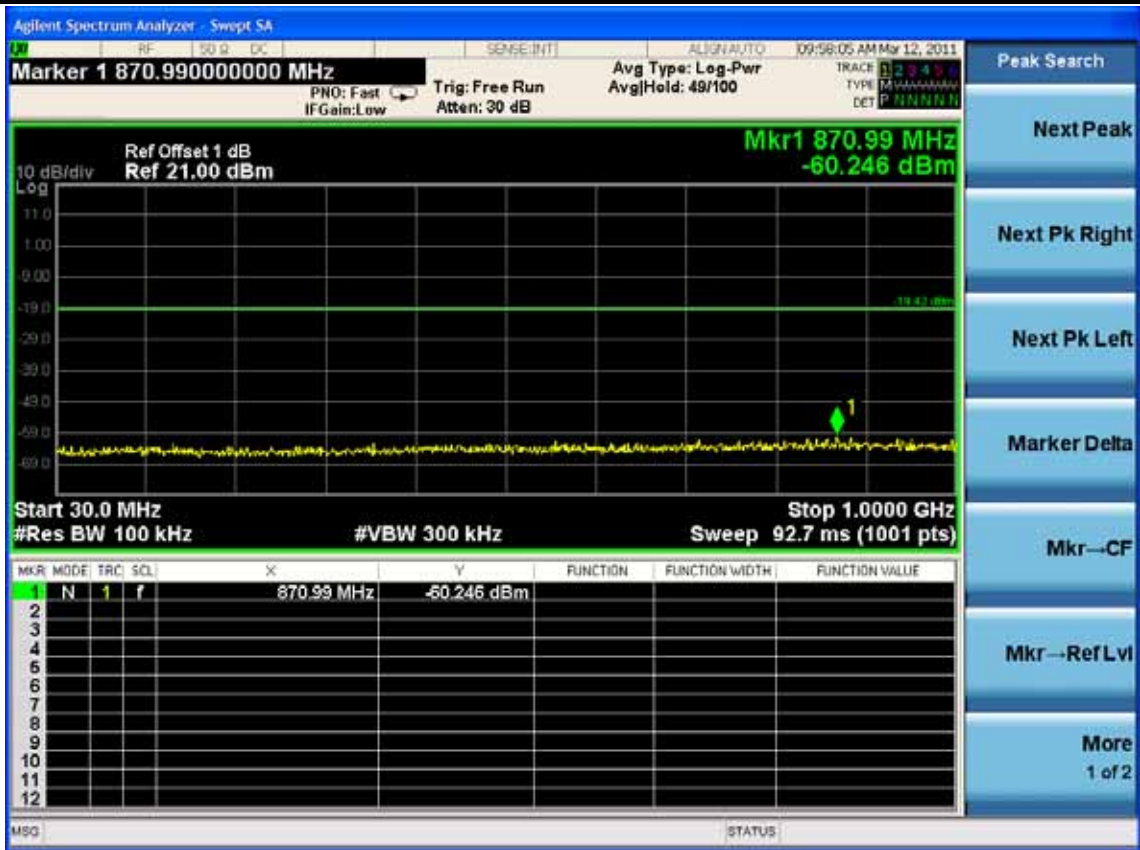



Hopping On
8-DPSK
2402MHz

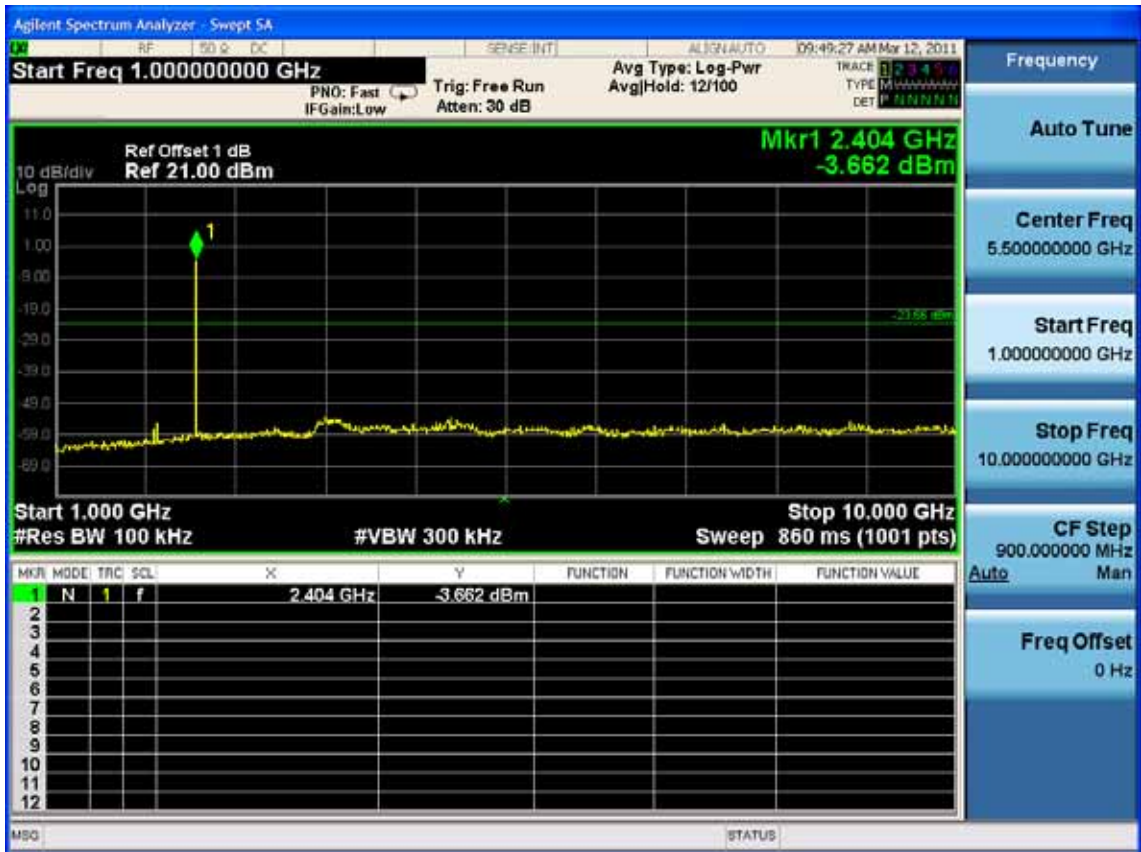

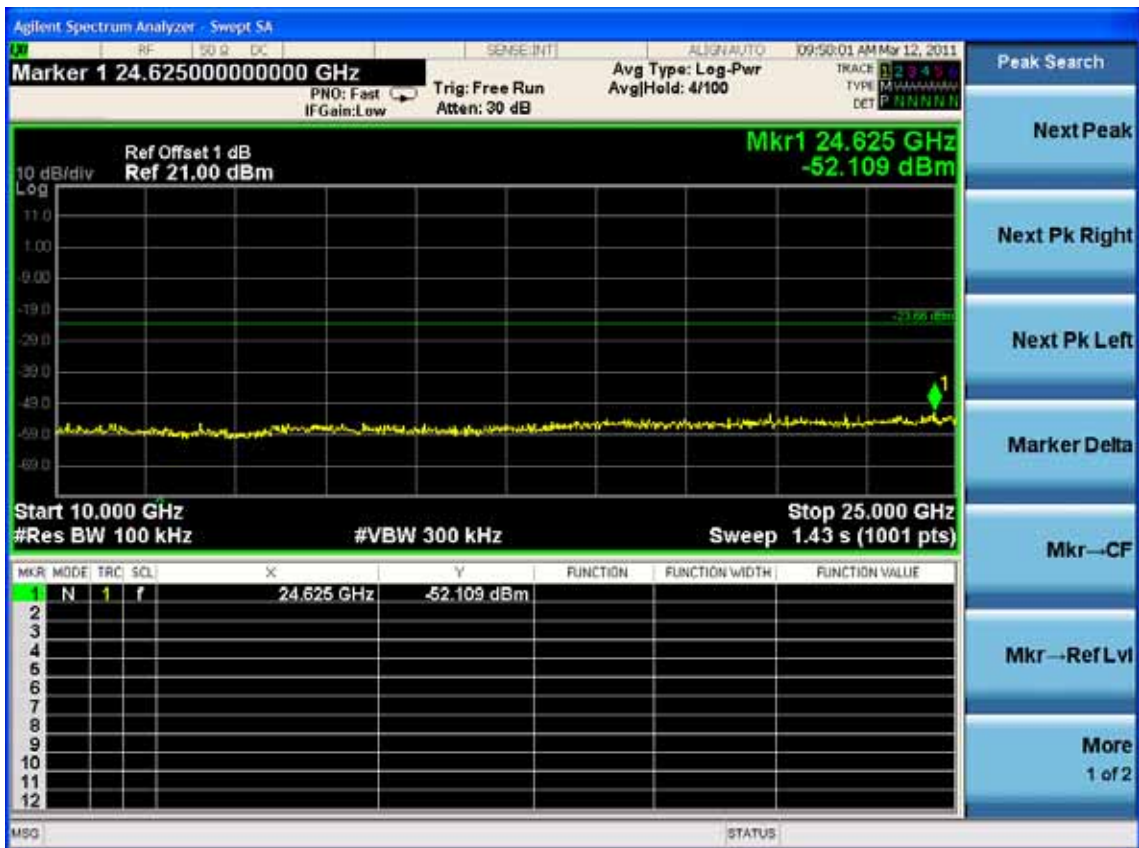
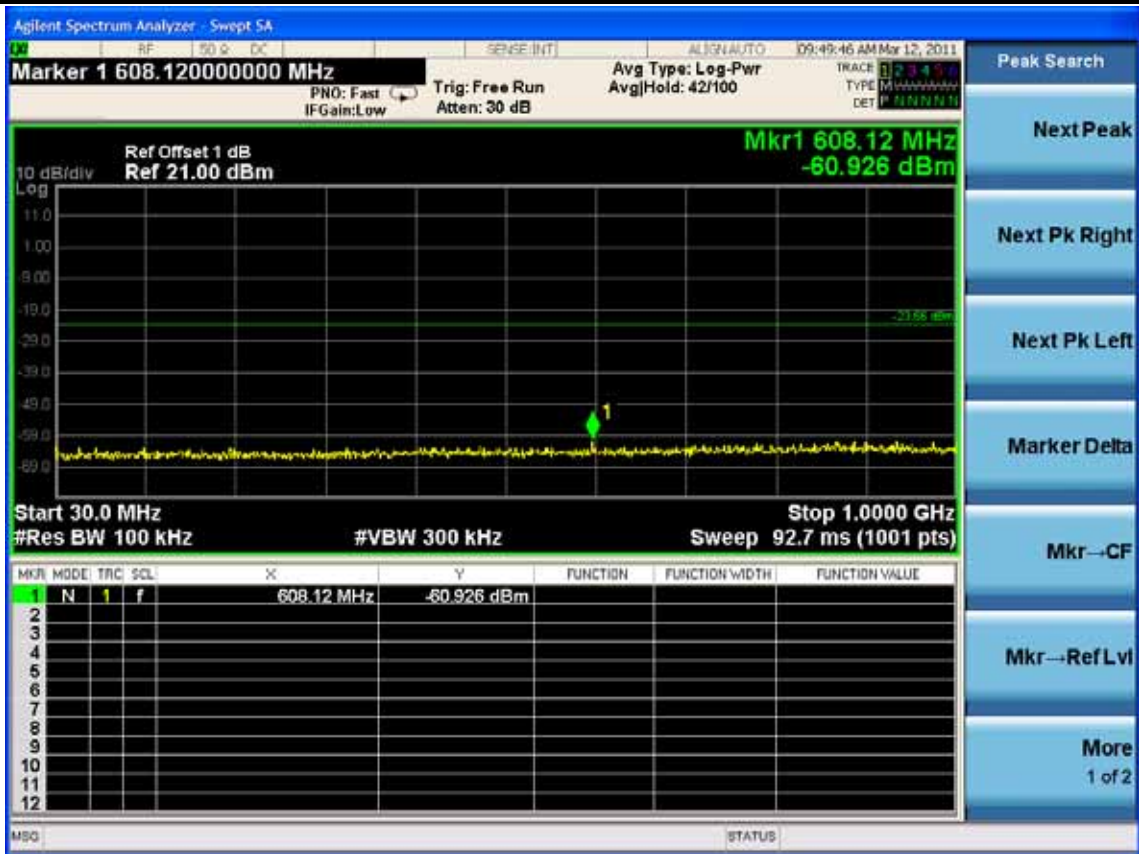

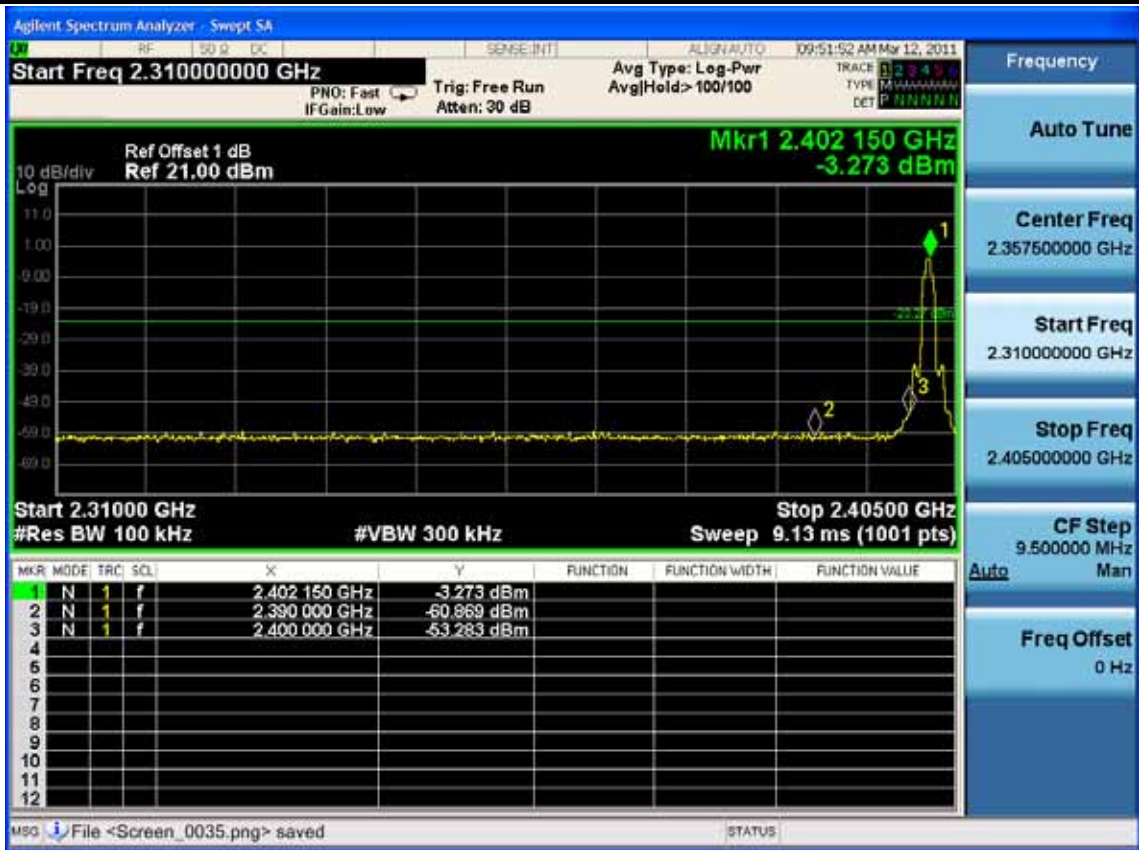

2441MHz

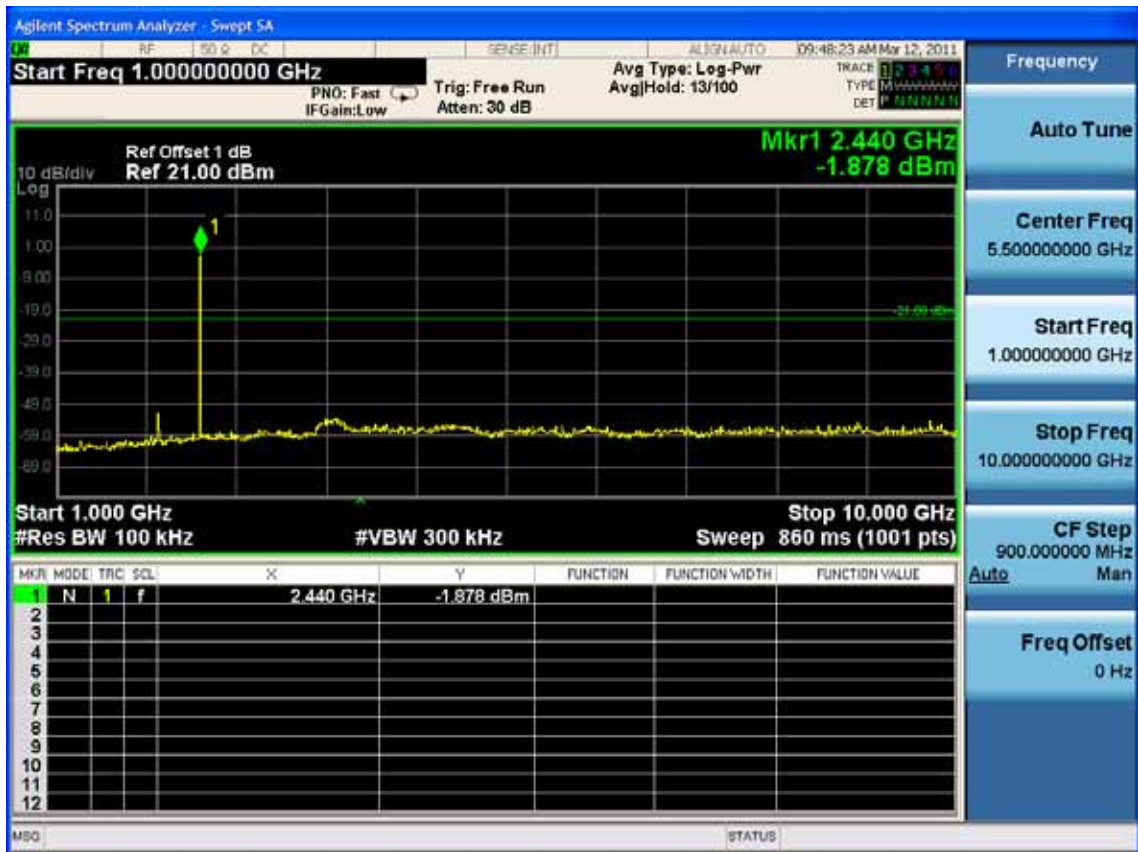

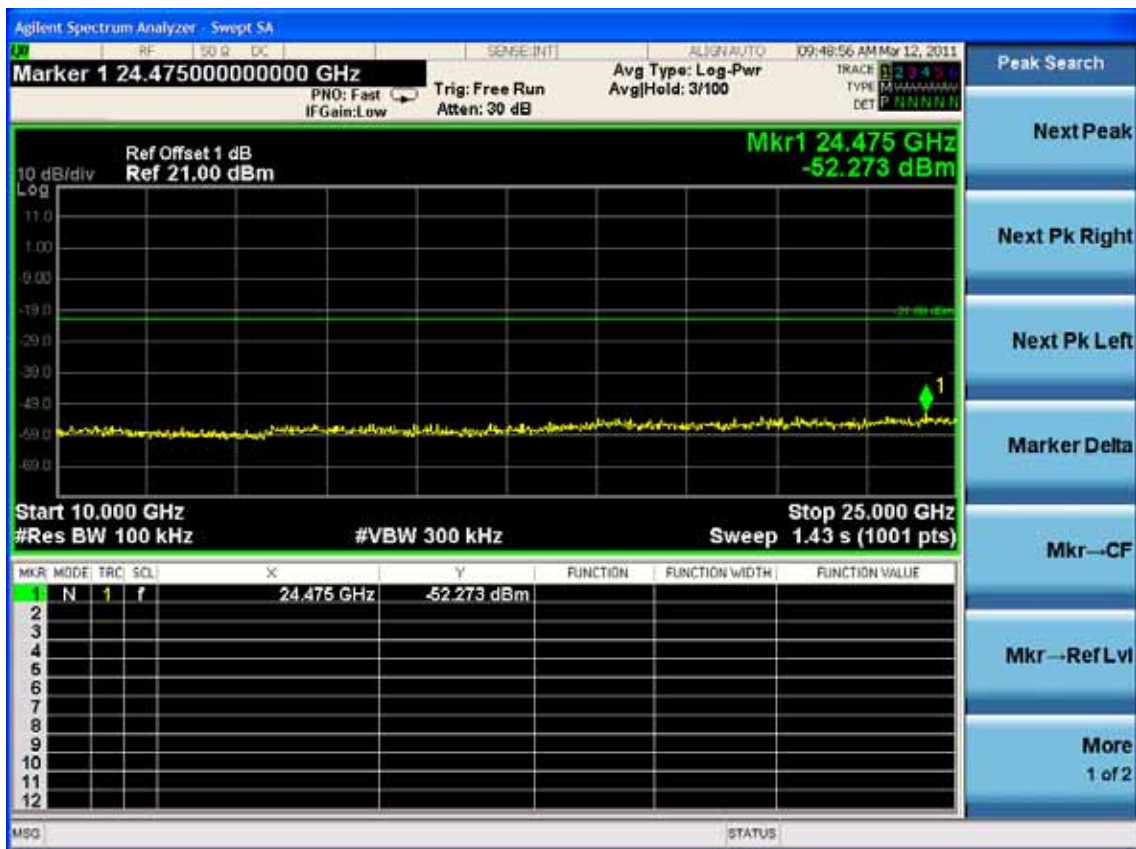
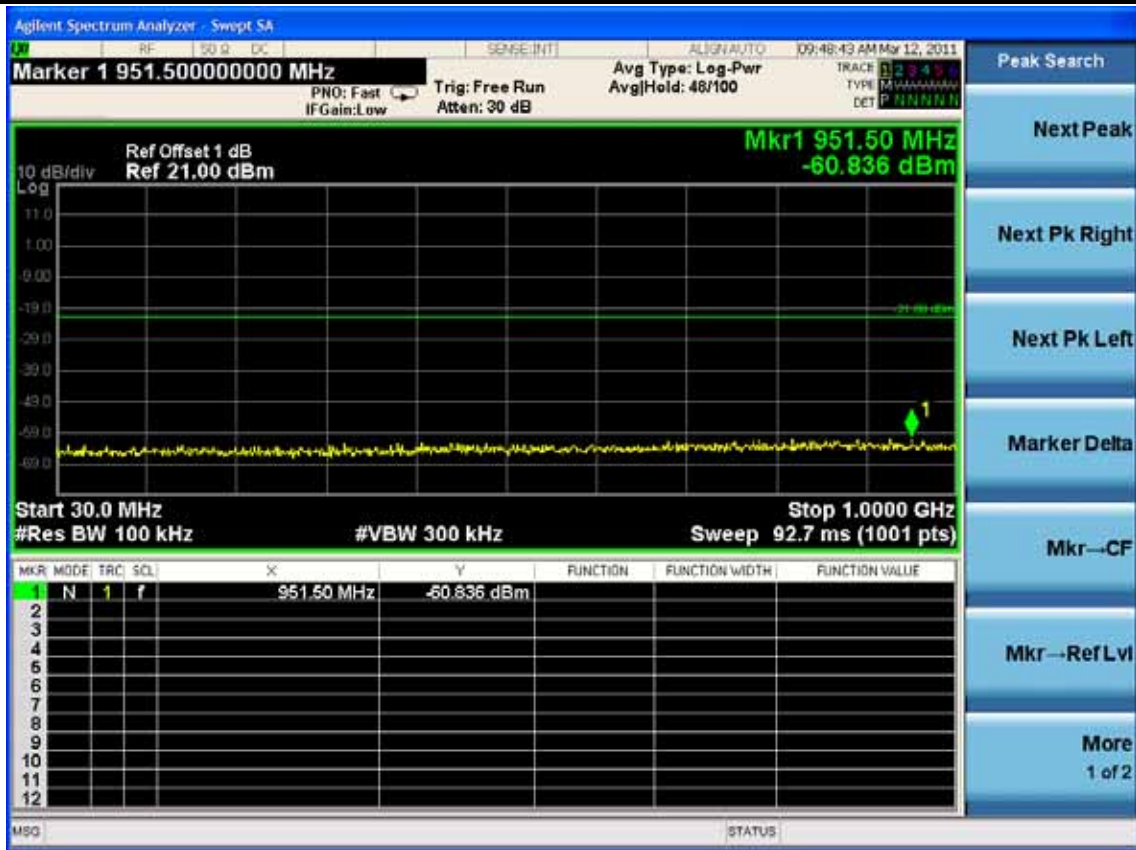

2480MHz

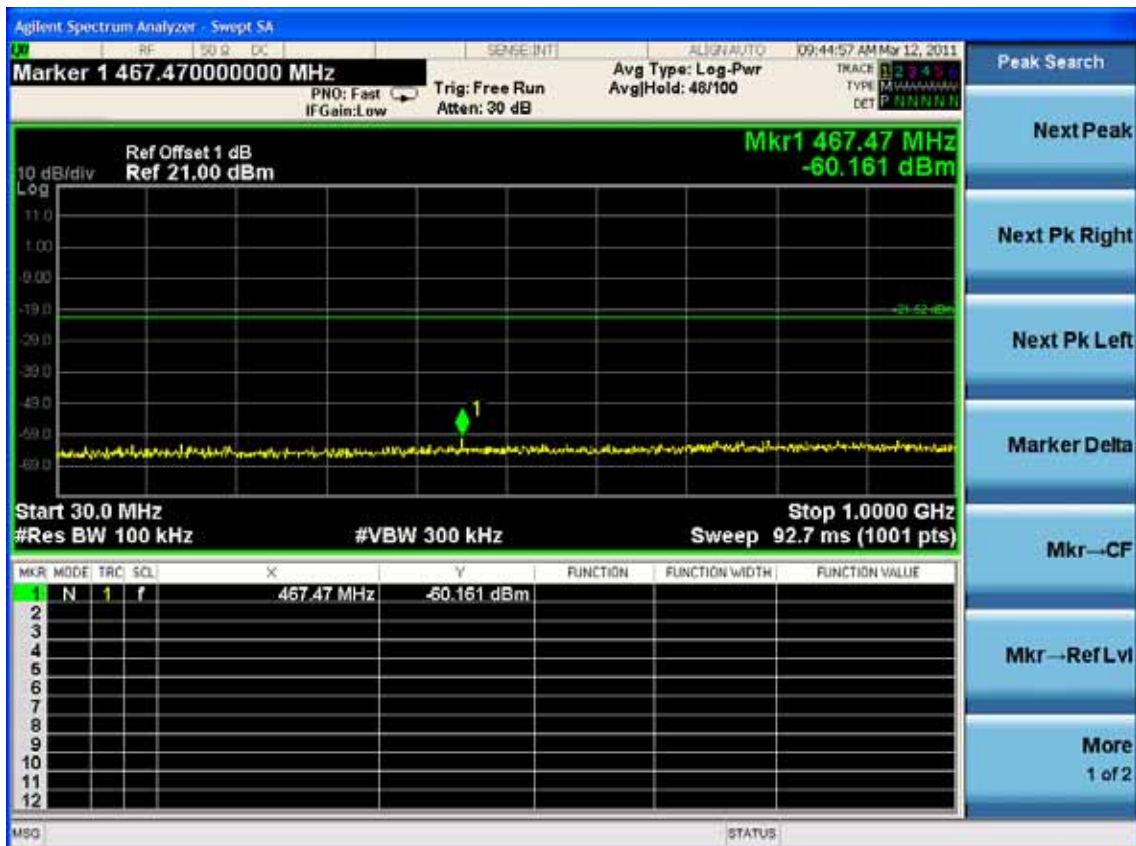
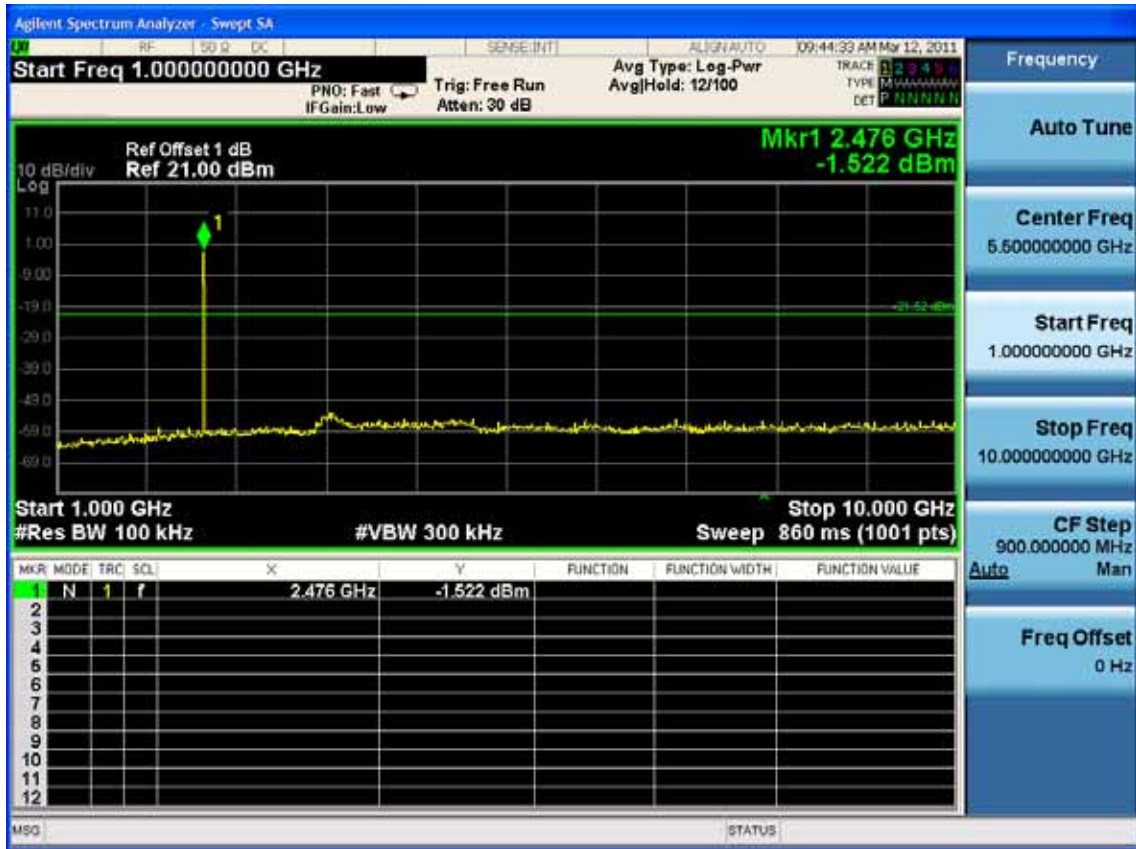

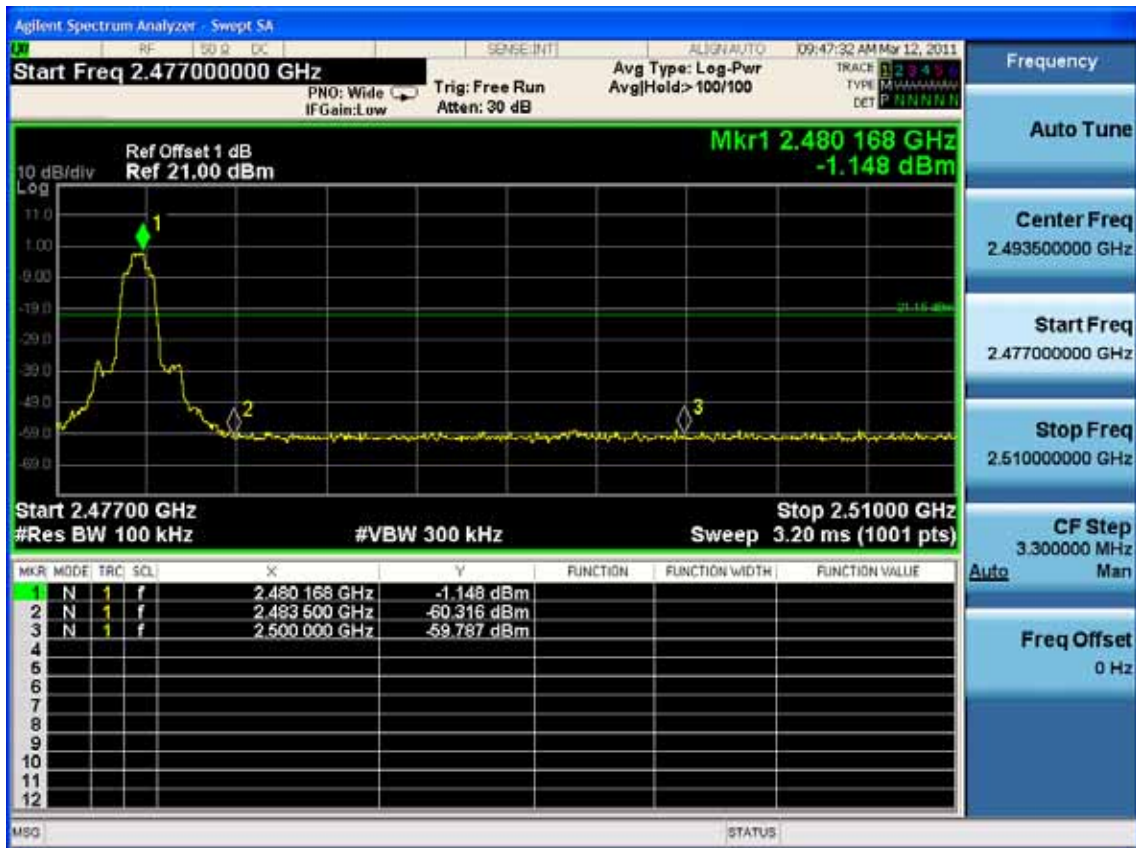
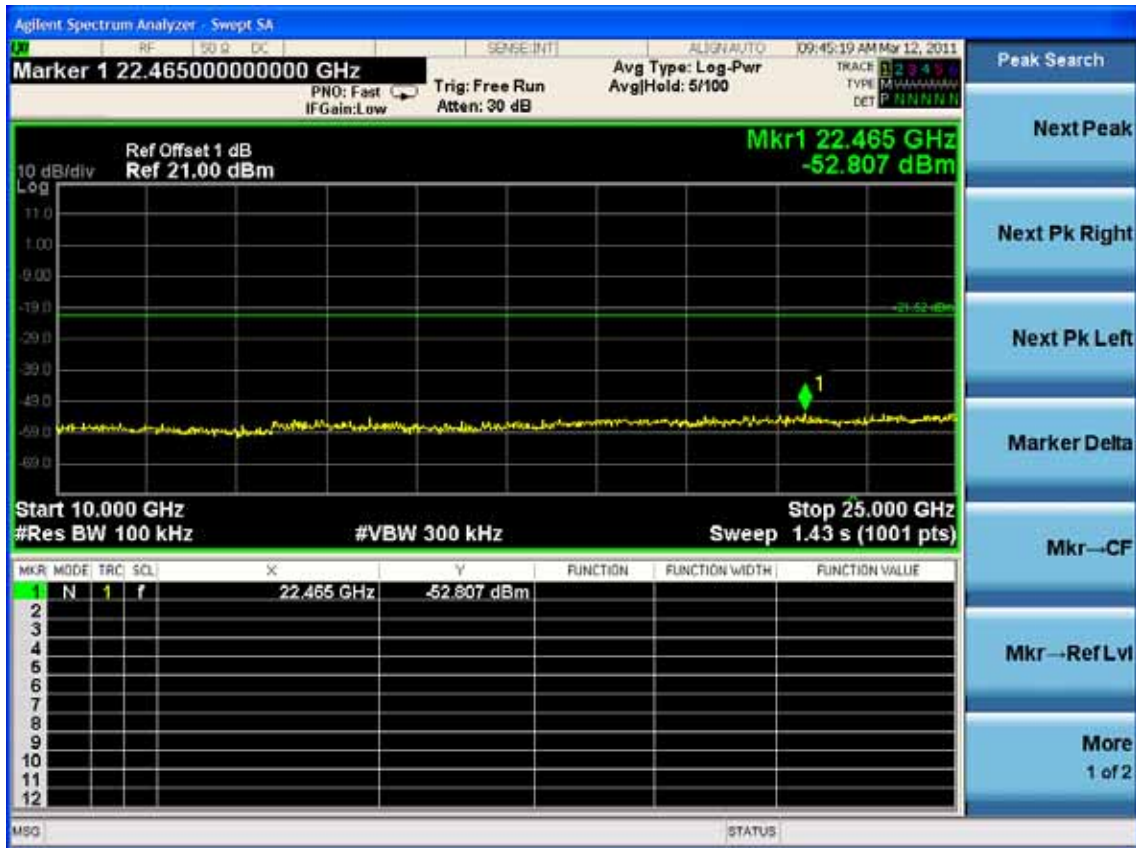

Hopping Off GFSK

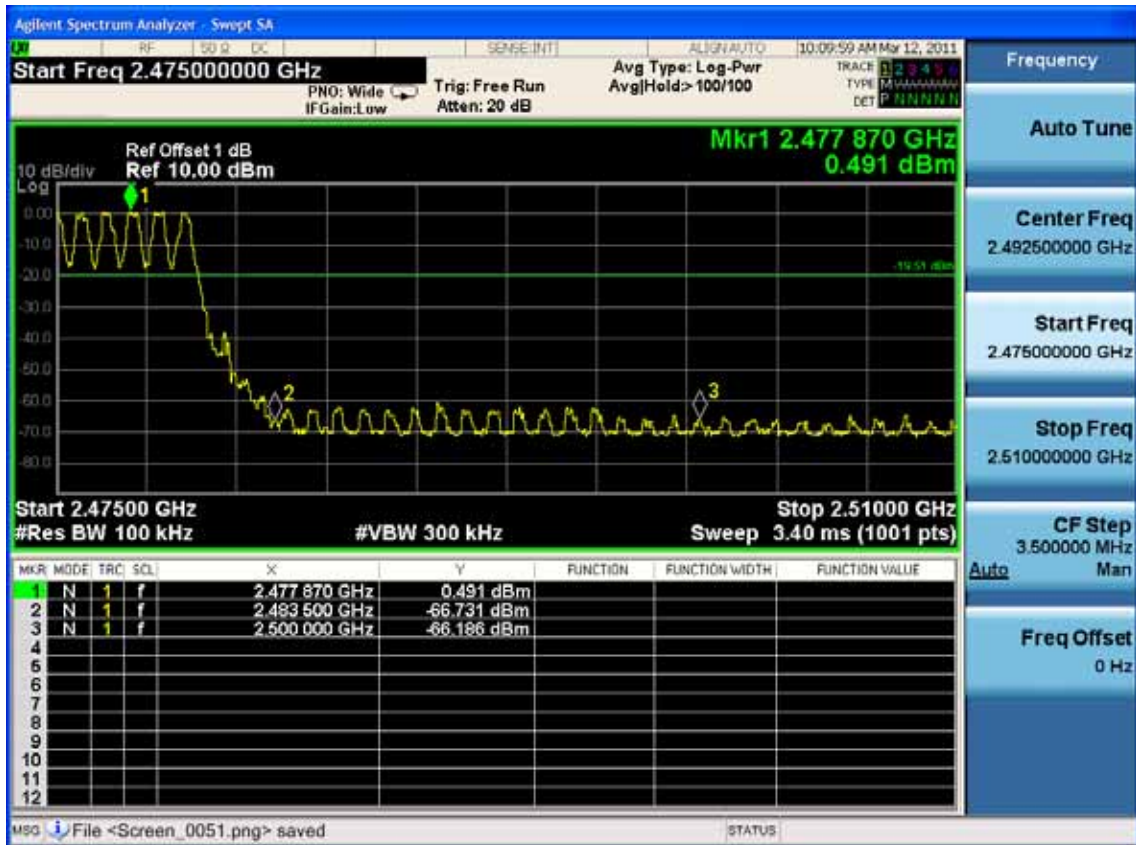
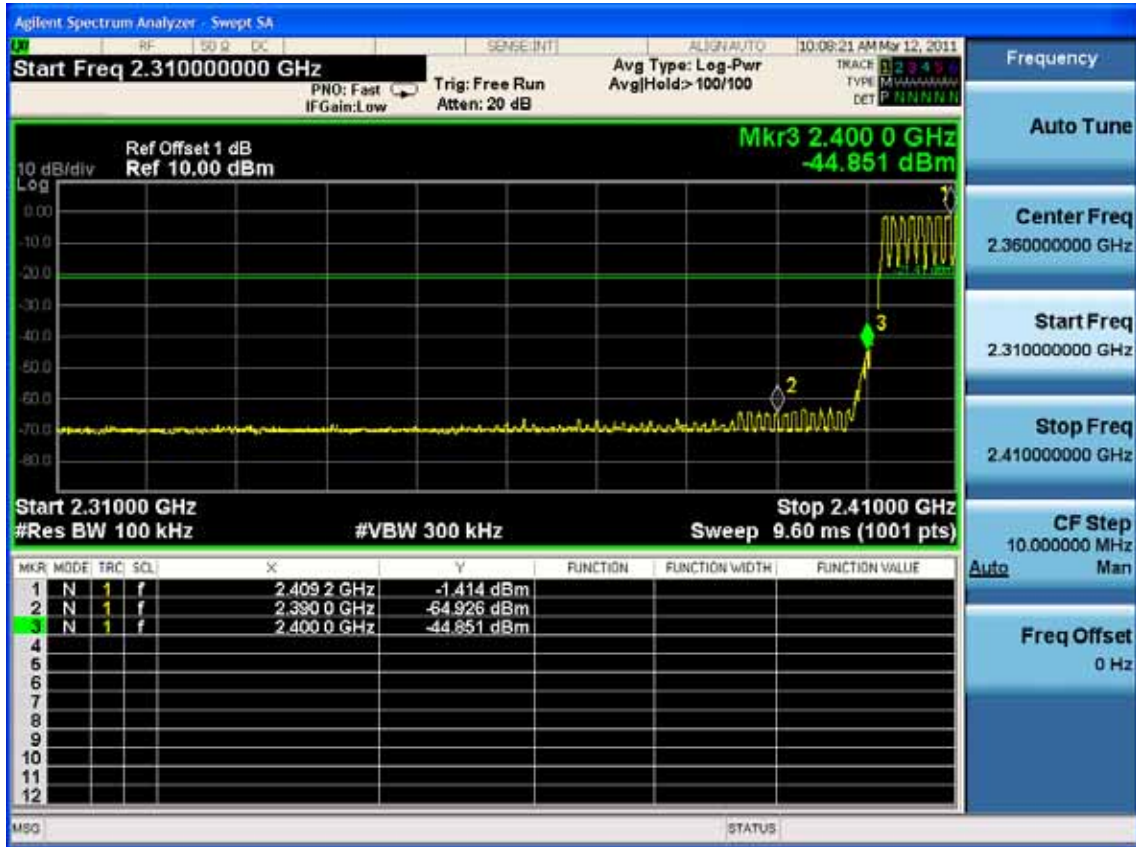

8-DPSK

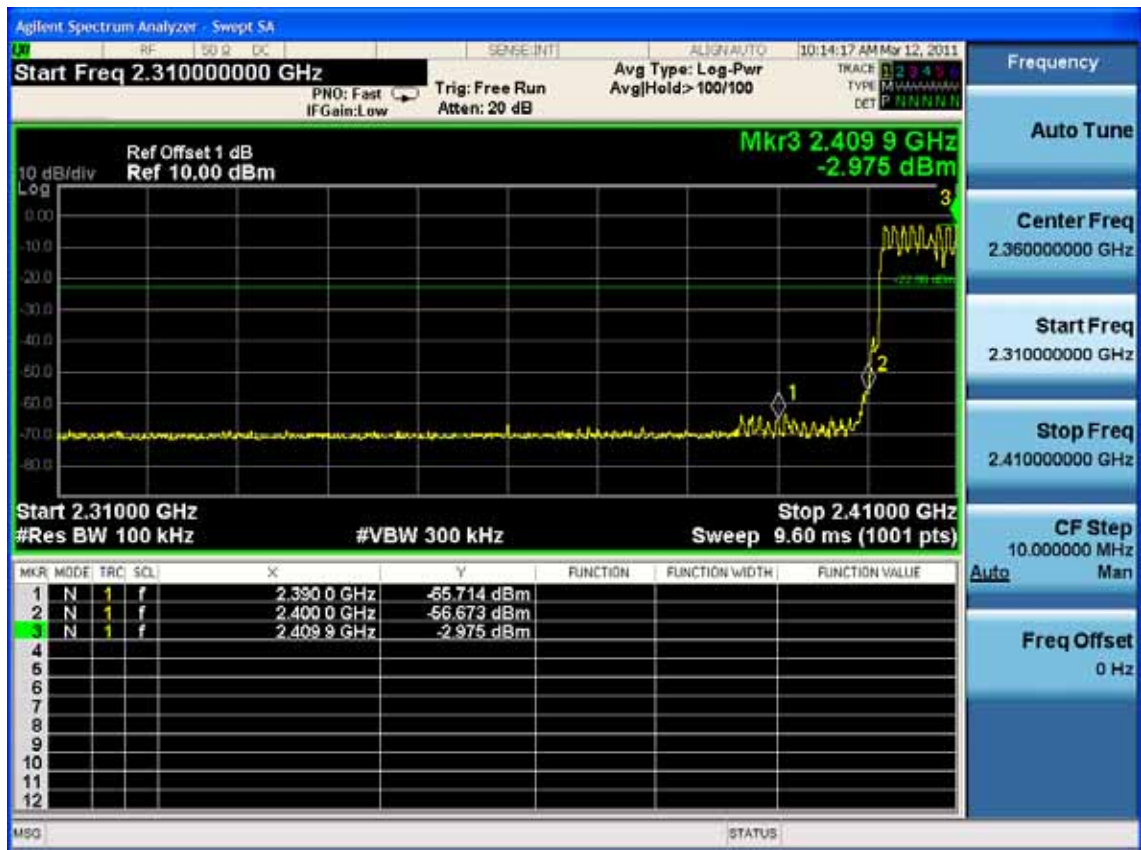
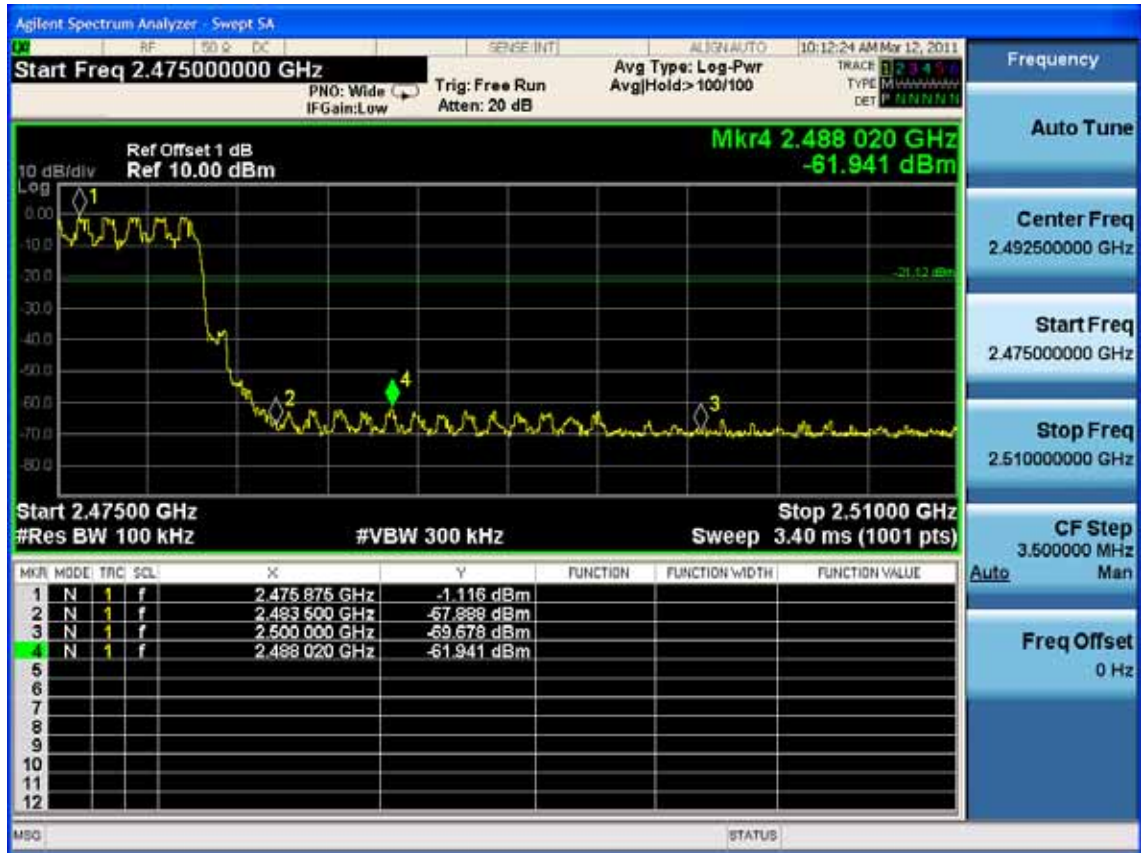

6. CARRIER FREQUENCY SEPARATION TEST

6.1. Test Equipment

Item	Equipment	Manufacturer	Model No.	Serial No.	Last Cal.	Cal. Interval
1	Spectrum Analyzer	Agilent	N9030A	MY51380221	Oct.31, 12	1 Year

6.2. Limit

Frequency hopping systems shall have hopping channel carrier frequency separated by a minimum of 25kHz or the 20dB bandwidth of the hopping channel, whichever is greater. Alternatively, frequency hopping systems operating in the 2400-2483.5 MHz band may have hopping channel carrier frequencies that are separated by 25 kHz or two-thirds of the 20 dB bandwidth of the hopping channel, whichever is greater, provided the systems operate with an output power no greater than 125 mW.

6.3. Test Results.

EUT: Universal Multi-Charging Station		
M/N: CR13		
Test date: 2013-08-14	Pressure: 101.1±1.0 kpa	Humidity : 51.6±3.0%
Tested by: Leo-Li	Test site: RF Site	Temperature : 21.8±0.6°C

Channel separation	Conclusion
1.00MHz	PASS



7. 20 DB BANDWIDTH TEST

7.1. Test Equipment

Item	Equipment	Manufacturer	Model No.	Serial No.	Last Cal.	Cal. Interval
1.	Spectrum Analyzer	Agilent	N9030A	MY51380221	Oct.31, 12	1 Year

7.2. Limit

Intentional radiators operating under the alternative provisions to the general emission limits, as contained in §§ 15.217 through 15.257 and in Subpart E of this part, must be designed to ensure that the 20 dB bandwidth of the emission, or whatever bandwidth may otherwise be specified in the specific rule section under which the equipment operates, is contained within the frequency band designated in the rule section under which the equipment is operated.

7.3. Test Results

EUT:Universal Multi-Charging Station		
M/N: CR13		
Test date: 2013-08-14	Pressure: 101.1±1.0 kpa	Humidity : 51.6±3.0%
Tested by: Leo-Li	Test site: RF Site	Temperature : 21.8±0.6°C

Test Mode	CH (MHz)	20dB bandwidth (KHz)	Limit (KHz)
GFSK	2402	859.1	N/A
	2441	911.7	N/A
	2480	866.8	N/A
8-DPSK	2402	1213	N/A
	2441	1213	N/A
	2480	1213	N/A
Conclusion : PASS			

GFSK

Test Frequency: 2402MHz



Test Frequency: 2441MHz



Test Frequency: 2480MHz



8DPSK

Test Frequency: 2402MHz



Test Frequency: 2441MHz



Test Frequency: 2480MHz



8. NUMBER OF HOPPING FREQUENCY TEST

8.1. Test Equipment

Item	Equipment	Manufacturer	Model No.	Serial No.	Last Cal.	Cal. Interval
1	Spectrum Analyzer	Agilent	N9030A	MY51380221	Oct.31, 12	1 Year

8.2. Limit

Frequency hopping systems in the 2400-2483.5 MHz band shall use at least 15 channels

8.3. Test Results

EUT: Universal Multi-Charging Station		
M/N: CR13		
Test date: 2013-08-14	Pressure: 101.1±1.0 kpa	Humidity : 51.6±3.0%
Tested by: Leo-Li	Test site: RF Site	Temperature : 21.8±0.6°C

Number of channel	Limit	Conclusion
79	≥15	PASS

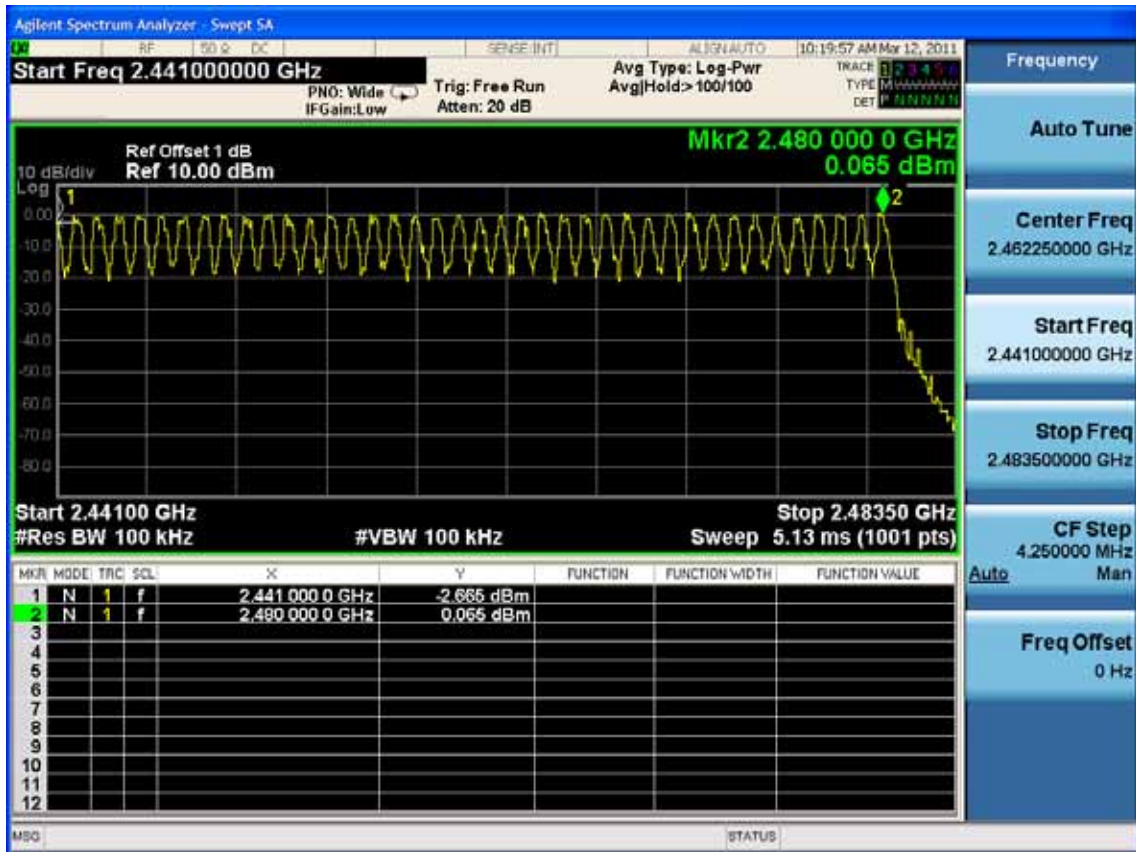
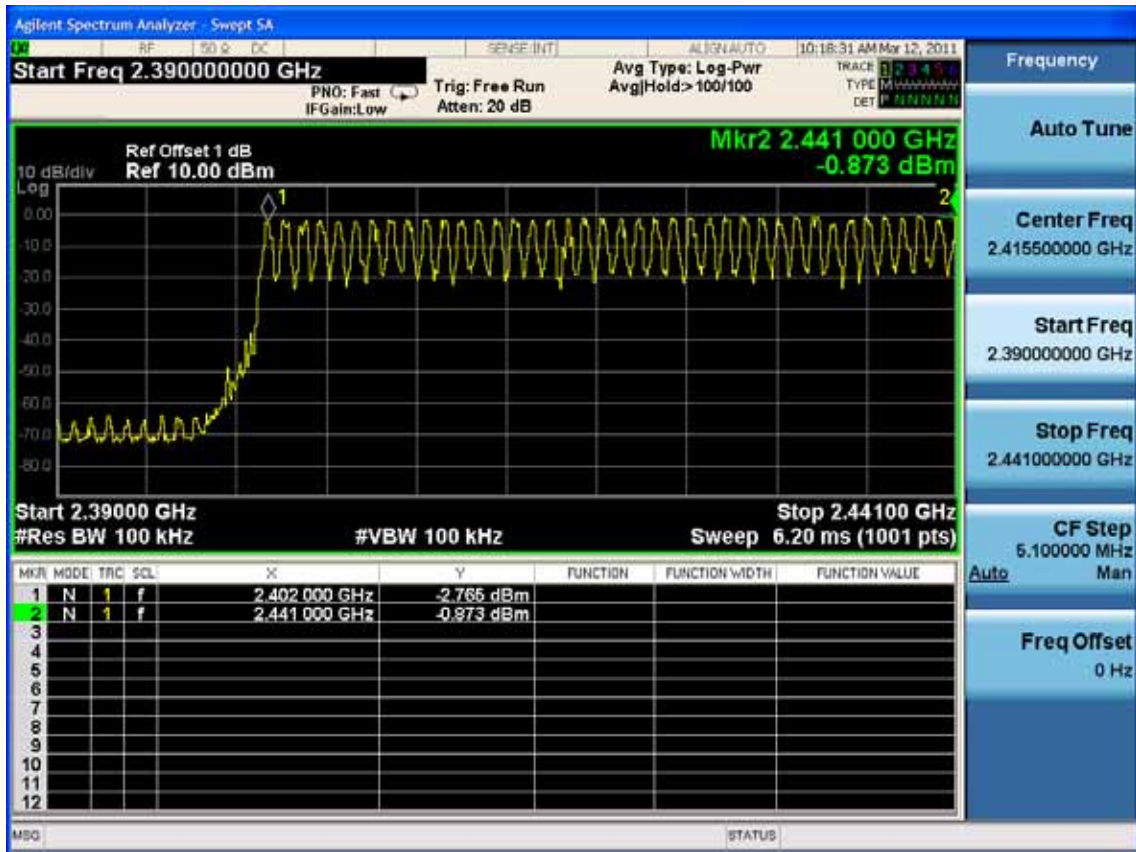

9. DWELL TIME

9.1. Test Equipment

Item	Equipment	Manufacturer	Model No.	Serial No.	Last Cal.	Cal. Interval
1	Spectrum Analyzer	Agilent	N9030A	MY51380221	Oct.31, 12	1 Year

9.2. Limit

The average time of occupancy on any channel shall not be greater than 0.4 seconds within a period of 0.4 seconds multiplied by the number of hopping channels employed.

9.3. Test Results

EUT:Universal Multi-Charging Station		
M/N: CR13		
Test date: 2013-08-14	Pressure: 101.1±1.0 kpa	Humidity : 51.6±3.0%
Tested by: Leo-Li	Test site: RF Site	Temperature : 21.8±0.6°C

Mode		dwell time	Limit	Conclusion
GFSK	DH1	49ps/5s*0.4*79chanel*0.411 m=127.27ms	<400ms	PASS
	DH3	26ps/5s*0.4*79chanel*1.689 ms =277.53ms	<400ms	PASS
	DH5	20hops/5s*0.4*79chanel*2.940ms=371.61ms	<400ms	PASS
8DPSK	DH1	51hops/5s*0.4*79chanel*0.421ms=135.69ms	<400ms	PASS
	DH3	25hops/5s*0.4*79chanel*1.680ms =265.44ms	<400ms	PASS
	DH5	20hops/5s*0.4*79chanel*2.950ms =372.88ms	<400ms	PASS

Note: All the lower levels were signal from receiver's, and should not considered in here.

GFSK
DH 1

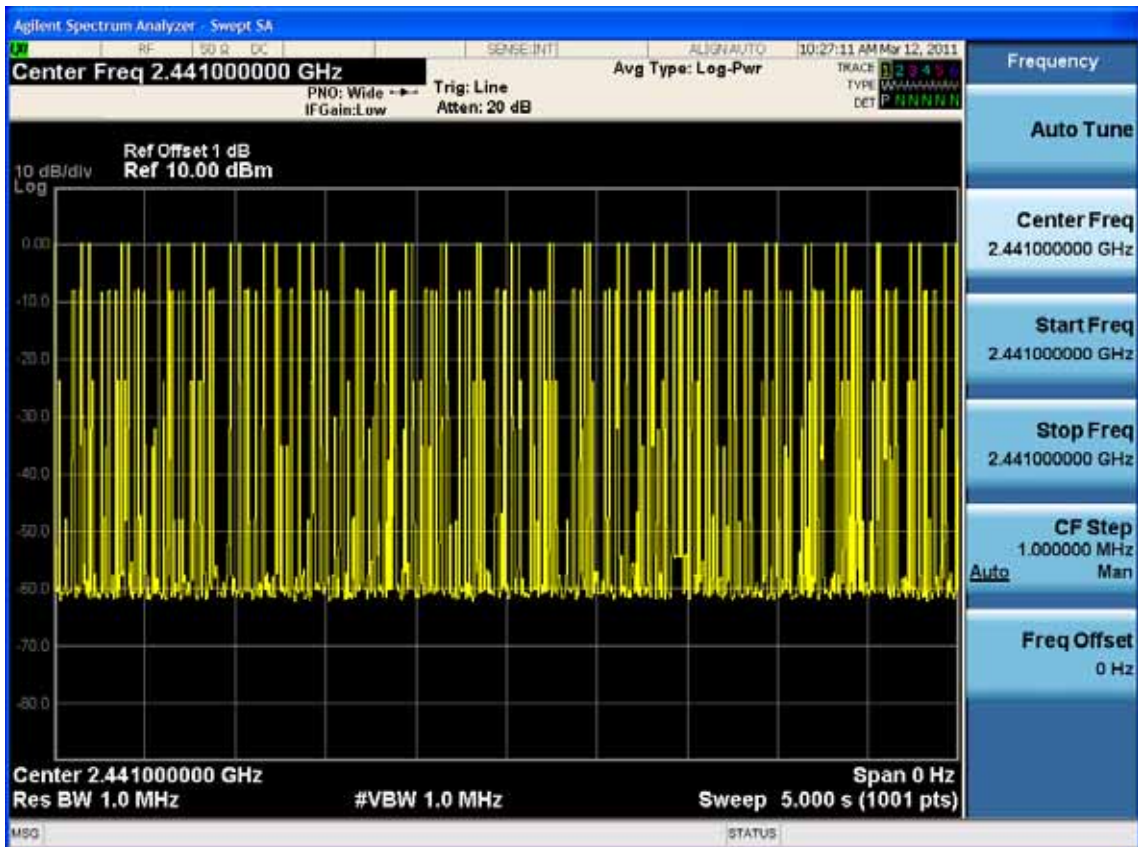
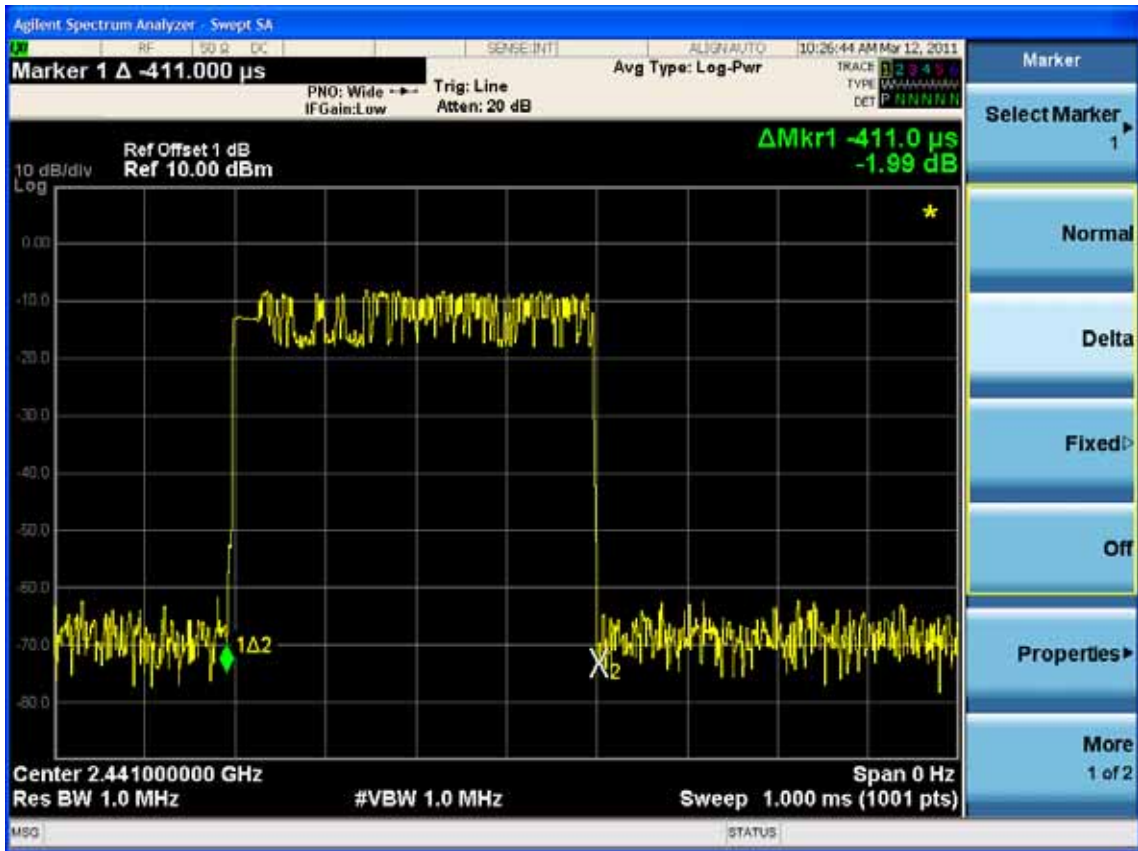

DH 3

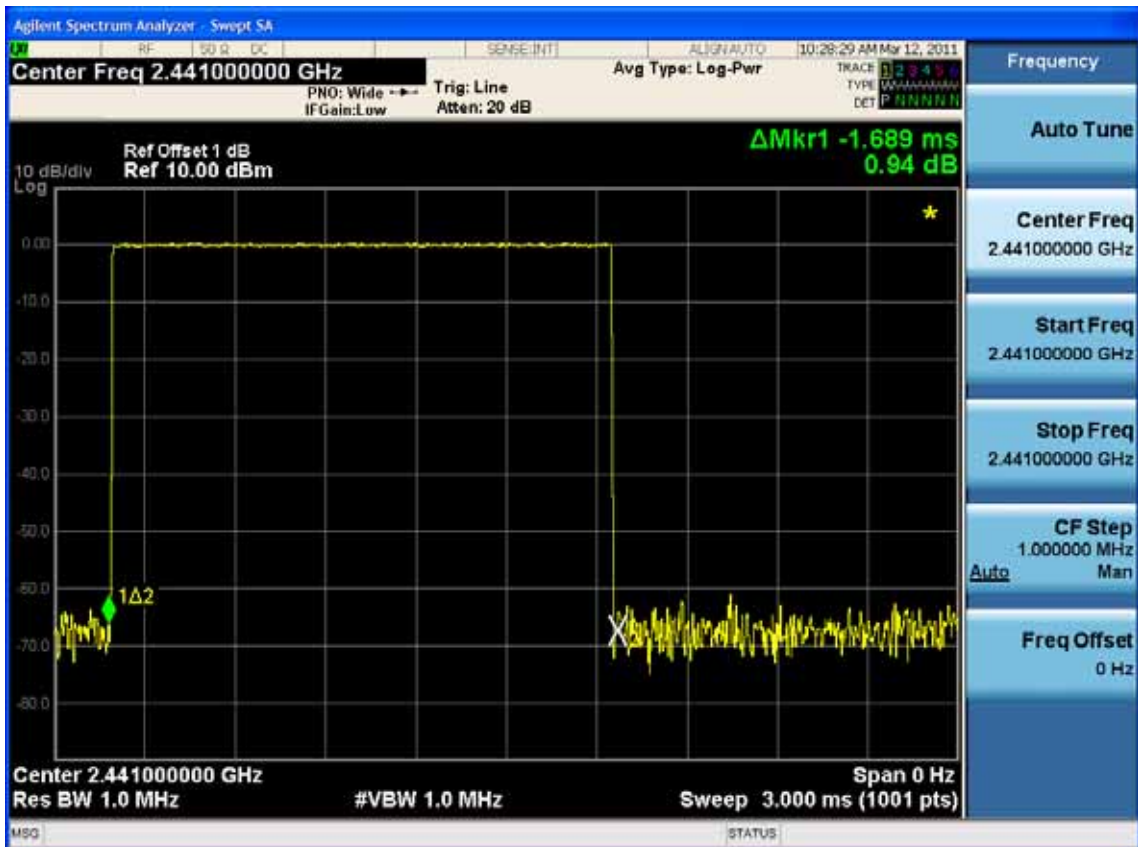
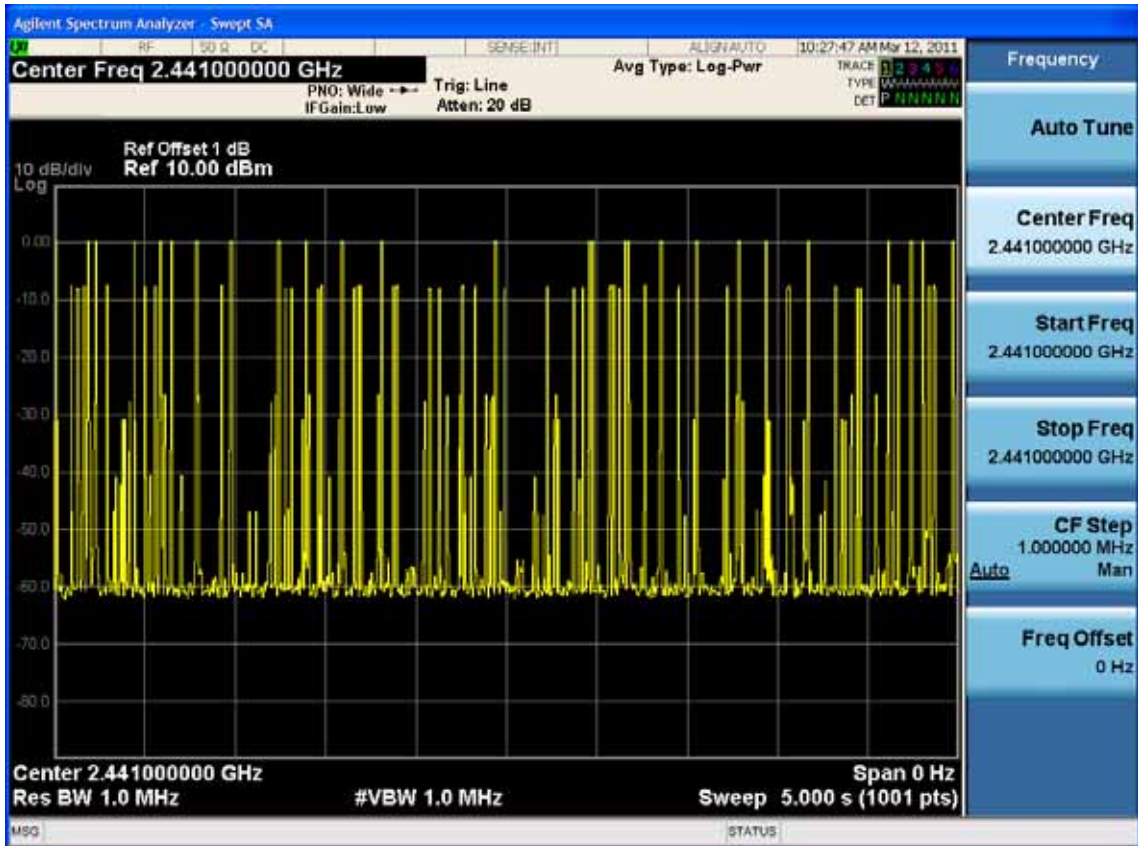

DH 5

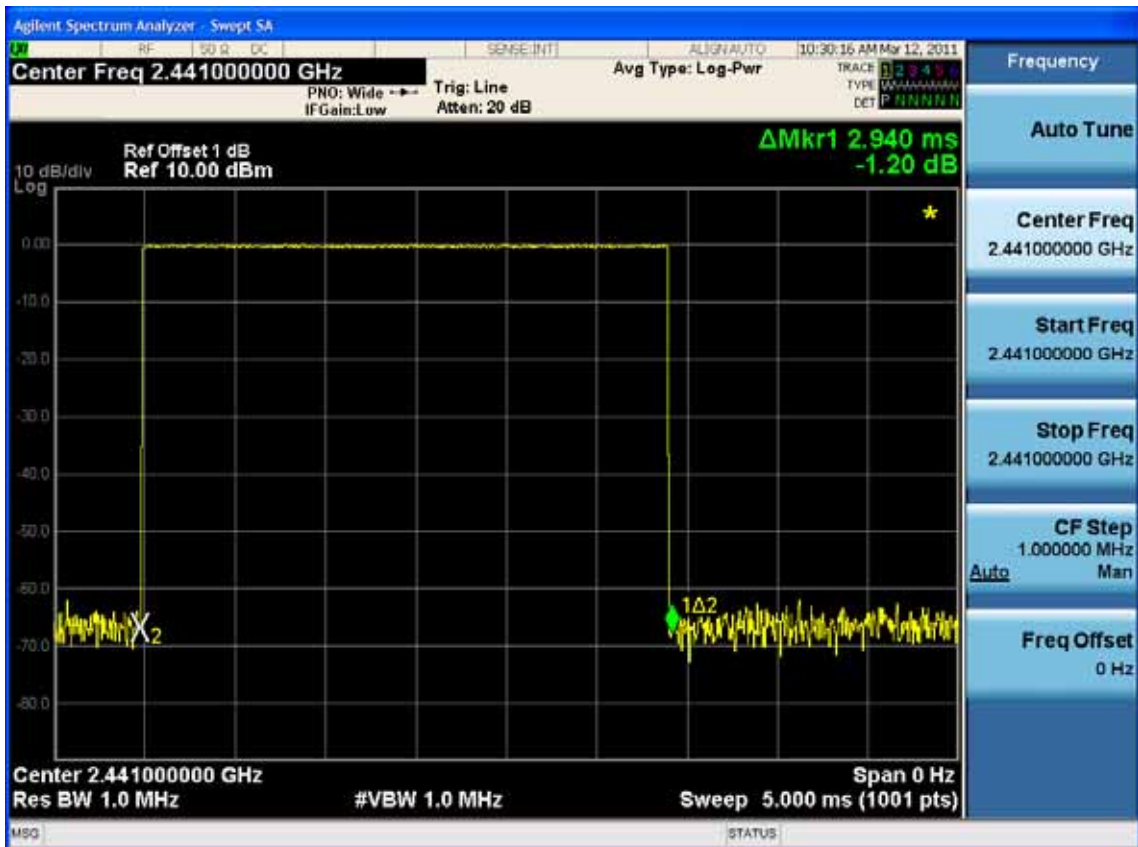
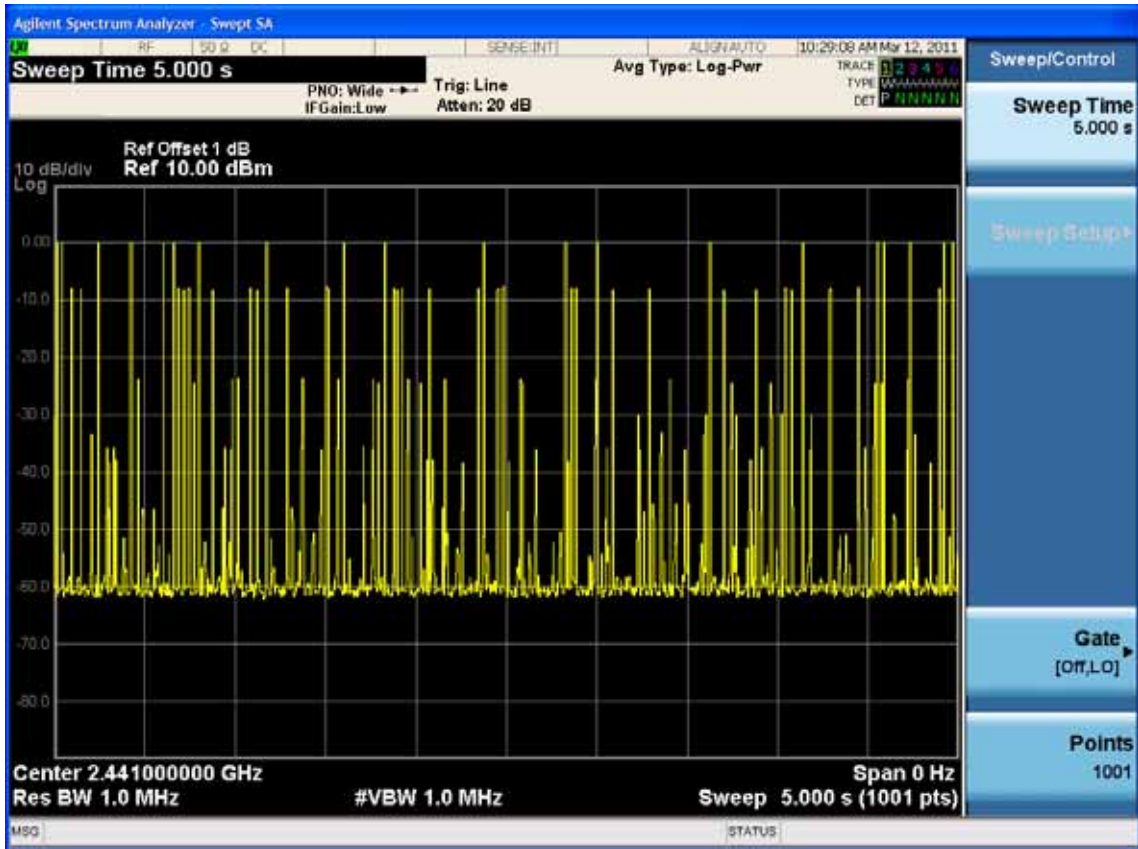

8DPSK
DH 1

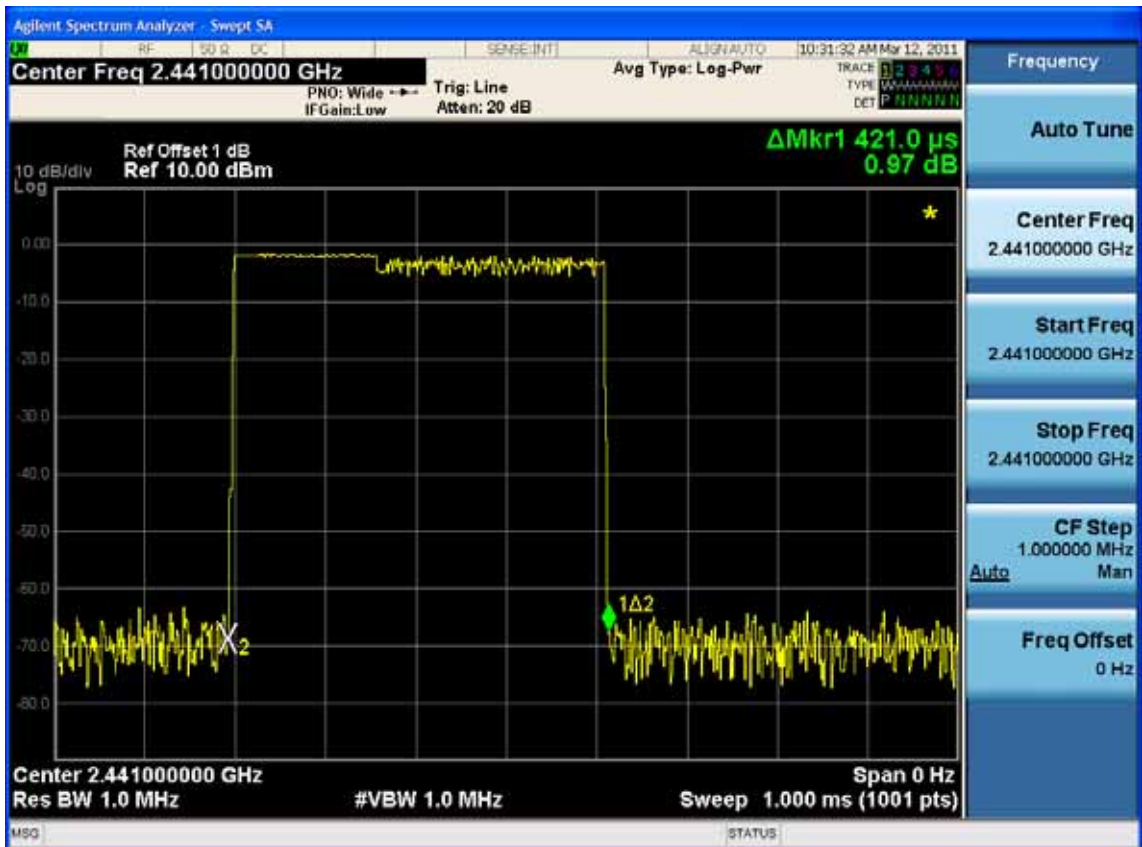
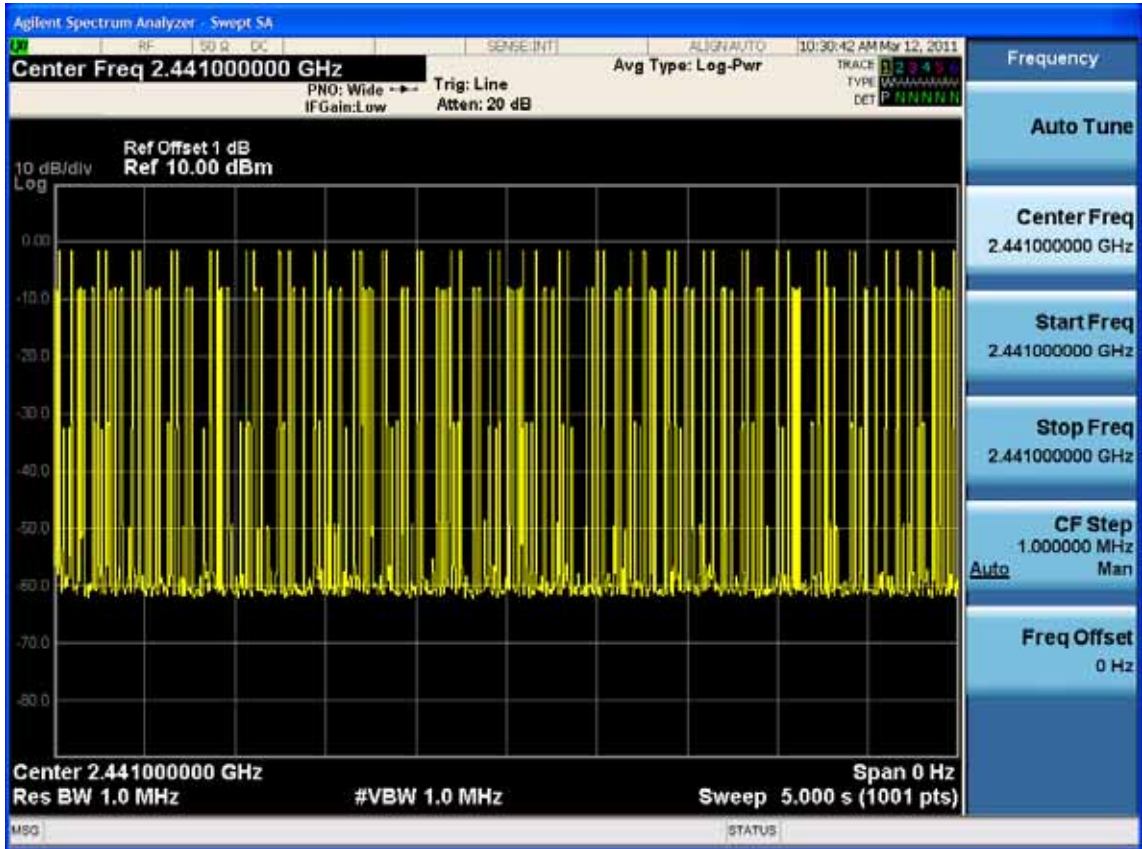

DH 3

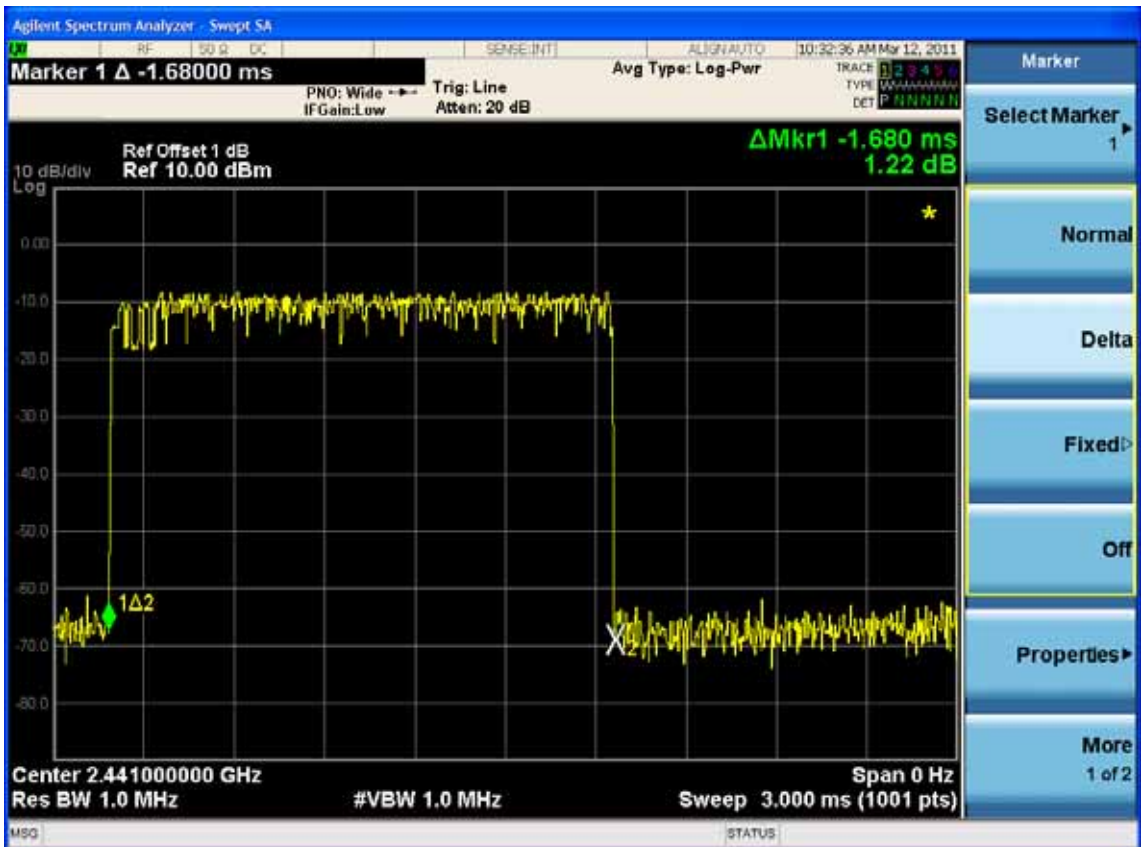
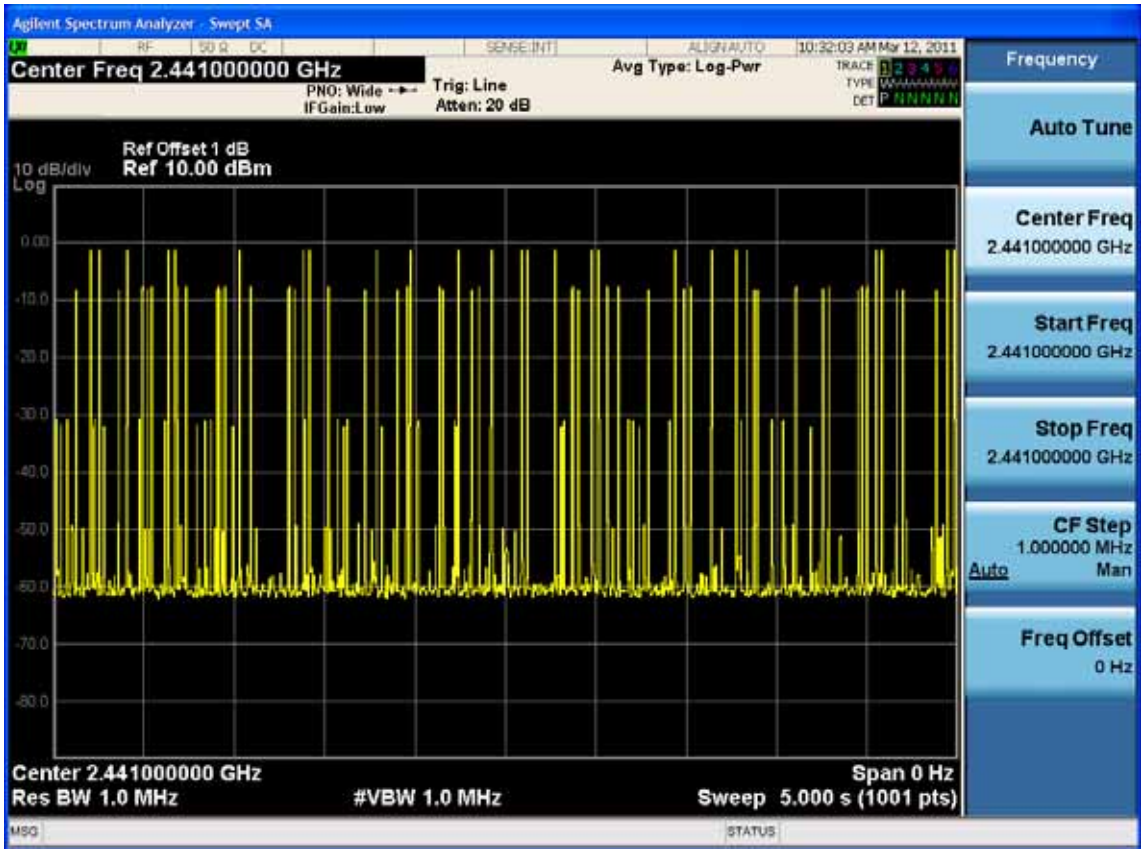

DH 5

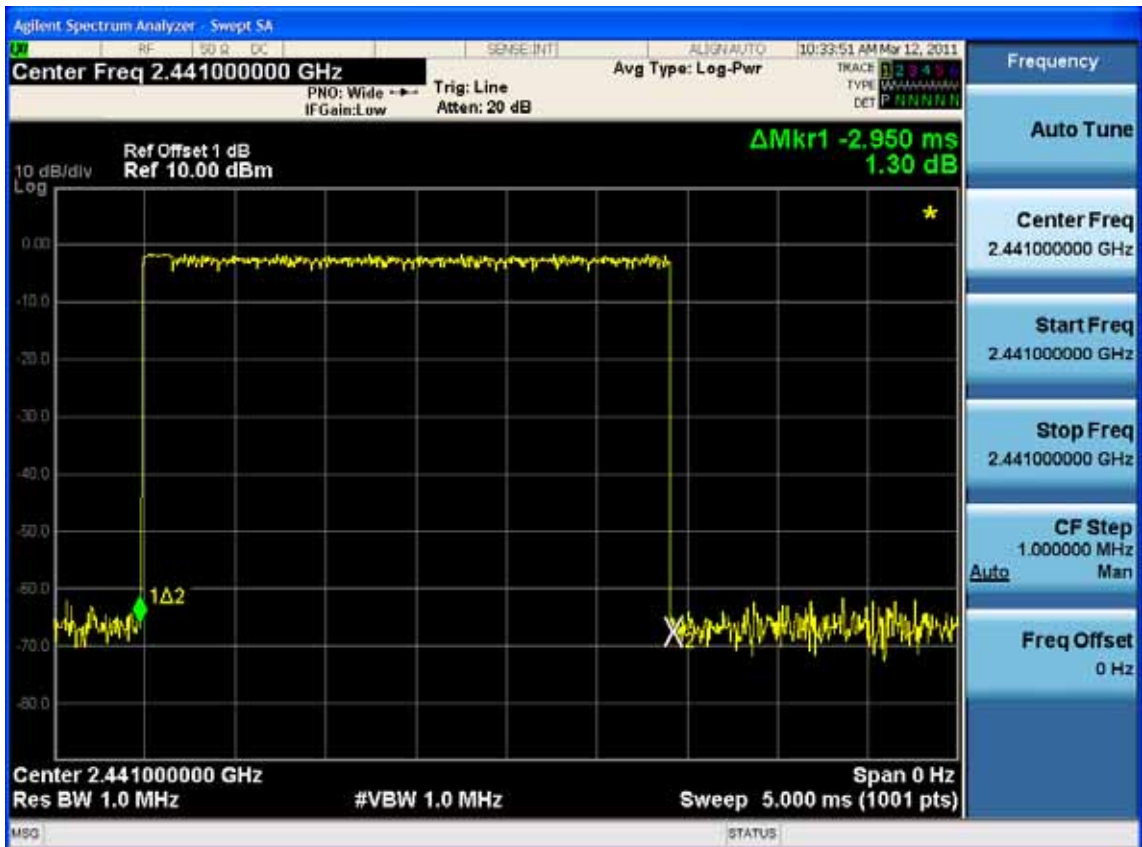
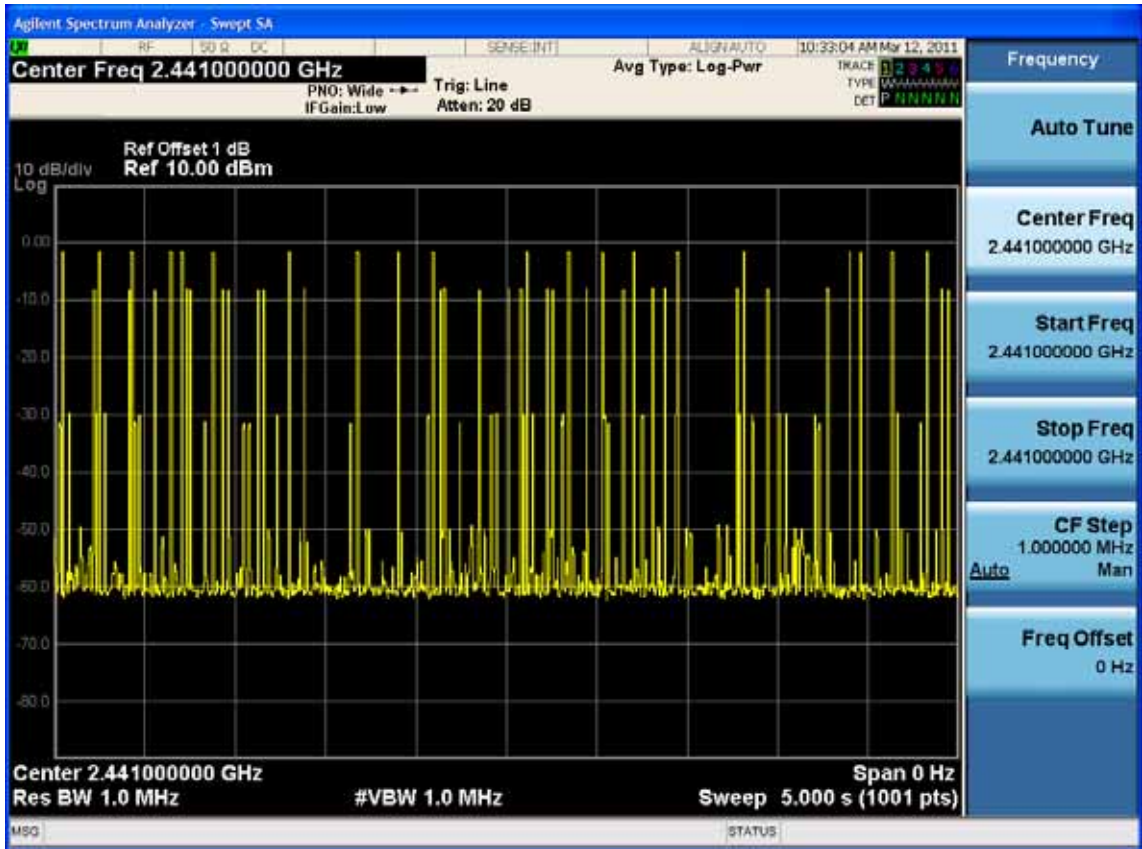

10. MAXIMUM PEAK OUTPUT POWER TEST

10.1. Test Equipment

Item	Equipment	Manufacturer	Model No.	Serial No.	Last Cal.	Cal. Interval
1.	Spectrum Analyzer	Agilent	E4446A	US44300459	May.08, 13	1 Year
2.	Horn Antenna	EMCO	3115	9607-4877	Aug.28, 12	1 Year
3.	Horn Antenna	EMCO	3116	00060089	Aug.28, 12	1 Year
4.	Signal Generator	HP	83732B	VS34490501	May.08, 13	1 Year
5.	Amplifier	Agilent	8491B	3008A02495	May.08, 13	1 Year
6.	RF Cable	Hubersuhner	SUCOFLEX 102	28620/2	May.08, 13	1 Year
7.	RF Cable	Hubersuhner	SUCOFLEX 102	28618/2	May.08, 13	1 Year
8.	RF Cable	Hubersuhner	SUCOFLEX 102	28610/2	May.08, 13	1 Year
9.	RF Cable	Hubersuhner	SUCOFLEX 102	274094/4	May.08, 13	1 Year

10.2. Limit

For frequency hopping systems operating in the 2400-2483.5 MHz band employing at least 75 non-overlapping hopping channels, and all frequency hopping systems in the 5725-5850 MHz band: 1 watt. For all other frequency hopping systems in the 2400-2483.5 MHz band: 0.125 watts.

10.3. Test Procedure

1. Connected the EUT's antenna port to spectrum analyzer.
2. Set the RBW> Bandwidth of test Frequency and put the test Frequency, Set the Span large enough to capture the entire signal
3. Use a peak detector on max hold
4. Reading the value from the Spectrum analyzer

Note: The cable loss and attenuator loss were offset into measure device as an amplitude offset.

10.4.Test Results

EUT: Universal Multi-Charging Station			
M/N: CR13			
Test date:2013-08-14		Pressure: 101.3±1.0 kpa	Humidity: 52.3±1.0%
Tested by: Leo-Li		Test site: RF site	Temperature:24.3±1.0 °C
Test Mode	CH (MHz)	Peak output Power (dBm)	Limit (dBm)
GFSK	2402	-1.281	30
	2441	0.358	30
	2480	1.072	30
8-DPSK	2402	-2.664	30
	2441	-1.091	30
	2480	-0.644	30
Conclusion: PASS			

11. BAND EDGE COMPLIANCE TEST

11.1. Test Equipment

Item	Equipment	Manufacturer	Model No.	Serial No.	Last Cal.	Cal. Interval
1.	Spectrum Analyzer	Agilent	E4446A	US44300459	May.08, 13	1 Year
2.	Horn Antenna	EMCO	3115	9607-4877	Aug.28, 12	1Year
3.	Amplifier	Agilent	8449B	3008A02495	May.08, 13	1 Year
4.	RF Cable	Hubersuhner	SUCOFLEX102	28620/2	May.08, 13	1 Year
5.	RF Cable	Hubersuhner	SUCOFLEX102	28618/2	May.08, 13	1 Year
6.	RF Cable	Hubersuhner	SUCOFLEX102	28610/2	May.08, 13	1 Year

11.2. Limit

All the lower and upper band-edges emissions appearing within 2310MHz to 2390MHz and 2483.5MHz to 2500MHz restricted frequency bands shall not exceed the limits shown in 15.209, all the other emissions outside operation frequency band 2400MHz to 2483.5MHz shall be at least 20dB below the fundamental emissions, or comply with 15.209 limits.

11.3. Test Produce

For upper band emissions that are up to two bandwidths(2MHz) away (2483.5MHz to 2485.5MHz) from the band-edge use below produce:

1. Choose a spectrum analyzer span that encompasses both the peak of the fundamental emission and the band-edge emission under investigation. Set the analyzer RBW to 100KHz and with a video bandwidth 300KHz. Record the peak levels of the fundamental emission and the relevant band-edge emission, Observe the stored trace and measure the amplitude delta between the peak of the fundamental and the peak of the band-edge emission. This is not a field strength measurement, it is only a relative measurement to determine the amount by which the emission drops at the band edge relative to the highest fundamental emission level.
2. Subtract the delta measured in step (1) from the maximum field strengths measured in clause 4 .The resultant field strengths are then used to determine band-edge compliance as required by Section 15.205

For emissions above two bandwidths away from the band-edge use below produce:

1. The EUT is placed on a turntable, which is 0.8m above the ground plane and worked at highest radiated power.
2. The turntable was rotated for 360 degrees to determine the position of maximum emission level.
3. EUT is set 3m away from the receiving antenna, which is varied from 1m to 4m to find out the highest emission.
4. Set the spectrum analyzer in the following setting in order to capture the lower and upperband-edges of the emission:
 - (a) PEAK: RBW=1MHz ;VBW=3MHz, PK detector, Sweep=AUTO
 - (b)This device is pulse modulated, a duty cycle factor was used to calculate average level based measured peak level

11.4. Test Results

Pass (The testing data was attached in the next pages.)

Note: If the PK measured levels comply with average limit, then the average level were deemed to comply with average limit.

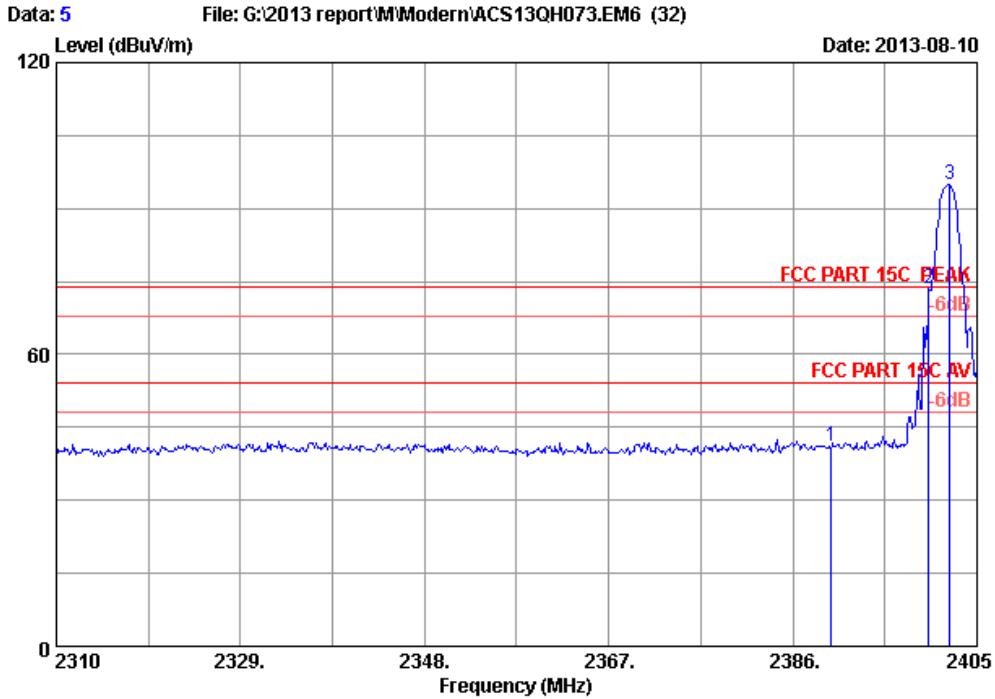

Site no. : 3m Chamber Data no. : 5
 Dis. / Ant. : 3m 2012 3115 (4580) Ant. pol. : HORIZONTAL
 Limit : FCC PART 15C PEAK
 Env. / Ins. : 23*C/54% Engineer : Leo-Li
 EUT : Universal Multi-Charging Station
 Power supply : DC 5V From Adapter Input AC 120V/60Hz
 Test mode : GFSK 2402MHz Tx
 M/N : CR13
 :

	Freq. (MHz)	Ant. Factor (dB/m)	Cable loss (dB)	Amp. Factor (dB)	Reading (dBuV)	Emission Level (dBuV/m)	Limits (dBuV/m)	Margin (dB)	Remark
1	2390.000	26.70	5.78	35.70	44.35	41.13	74.00	32.87	Peak
2	2400.000	26.76	5.80	35.70	76.51	73.37	74.00	0.63	Peak
3	2402.230	26.77	5.80	35.70	97.98	94.85	74.00	-20.85	Peak

Remarks:

1. Emission Level= Antenna Factor + Cable Loss -Amp Factor + Reading.
2. The emission levels that are 20dB below the official limit are not reported.

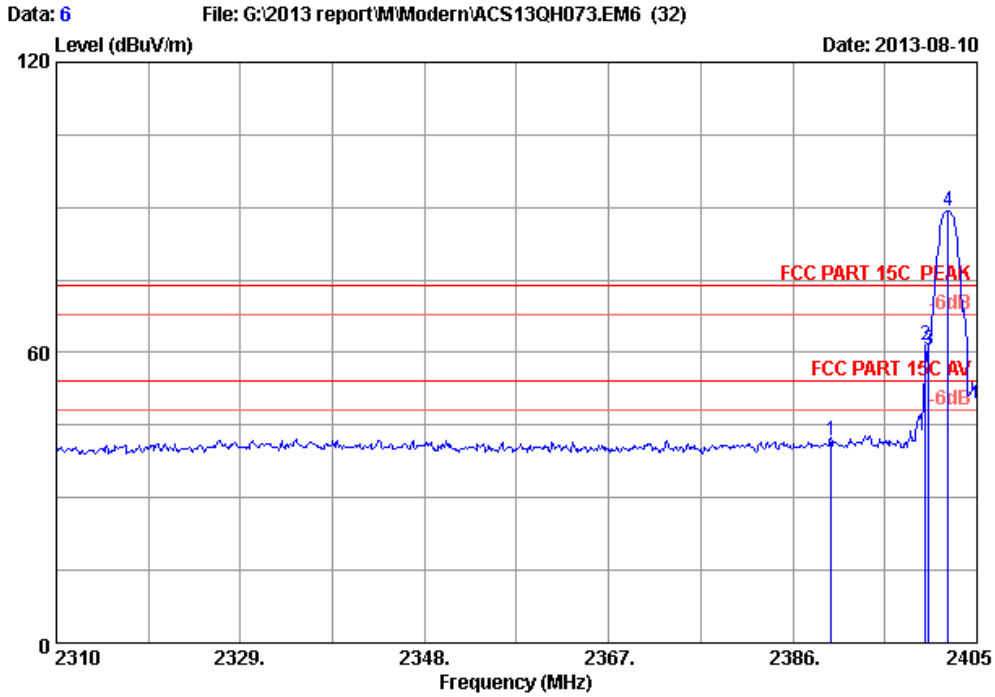

Site no. : 3m Chamber Data no. : 6
 Dis. / Ant. : 3m 2012 3115 (4580) Ant. pol. : VERTICAL
 Limit : FCC PART 15C PEAK
 Env. / Ins. : 23°C/54% Engineer : Leo-Li
 EUT : Universal Multi-Charging Station
 Power supply : DC 5V From Adapter Input AC 120V/60Hz
 Test mode : GFSK 2402MHz Tx
 M/N : CR13
 :

	Freq. (MHz)	Ant. Factor (dB/m)	Cable loss (dB)	Amp. Factor (dB)	Reading (dBuV)	Emission Level (dBuV/m)	Limits (dBuV/m)	Margin (dB)	Remark
1	2390.000	26.70	5.78	35.70	44.90	41.68	74.00	32.32	Peak
2	2399.700	26.76	5.80	35.70	64.70	61.56	74.00	12.44	Peak
3	2400.000	26.76	5.80	35.70	63.78	60.64	74.00	13.36	Peak
4	2402.000	26.77	5.80	35.70	92.38	89.25	74.00	-15.25	Peak

Remarks:

1. Emission Level= Antenna Factor + Cable Loss -Amp Factor + Reading.
2. The emission levels that are 20dB below the official limit are not reported.

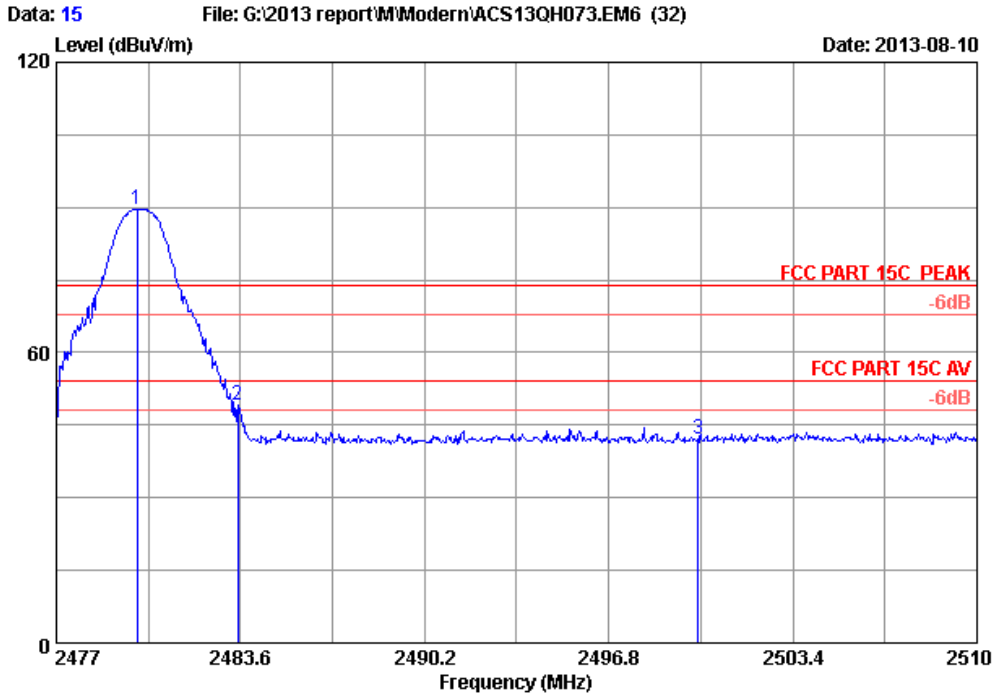

Site no. : 3m Chamber Data no. : 15
 Dis. / Ant. : 3m 2012 3115 (4580) Ant. pol. : VERTICAL
 Limit : FCC PART 15C PEAK
 Env. / Ins. : 23°C/54% Engineer : Leo-Li
 EUT : Universal Multi-Charging Station
 Power supply : DC 5V From Adapter Input AC 120V/60Hz
 Test mode : GFSK 2480MHz Tx
 M/N : CR13
 :

	Freq.	Ant.	Cable	Amp.	Emission				
	(MHz)	Factor	loss	Factor	Reading	Level	Limits	Margin	Remark
		(dB/m)	(dB)	(dB)	(dBuV)	(dBuV/m)	(dBuV/m)	(dB)	
1	2479.904	27.27	5.91	35.70	92.09	89.57	74.00	-15.57	Peak
2	2483.500	27.29	5.92	35.70	51.56	49.07	74.00	24.93	Peak
3	2500.000	27.40	5.94	35.70	44.36	42.00	74.00	32.00	Peak

Remarks:

1. Emission Level= Antenna Factor + Cable Loss -Amp Factor + Reading.
2. The emission levels that are 20dB below the official limit are not reported.

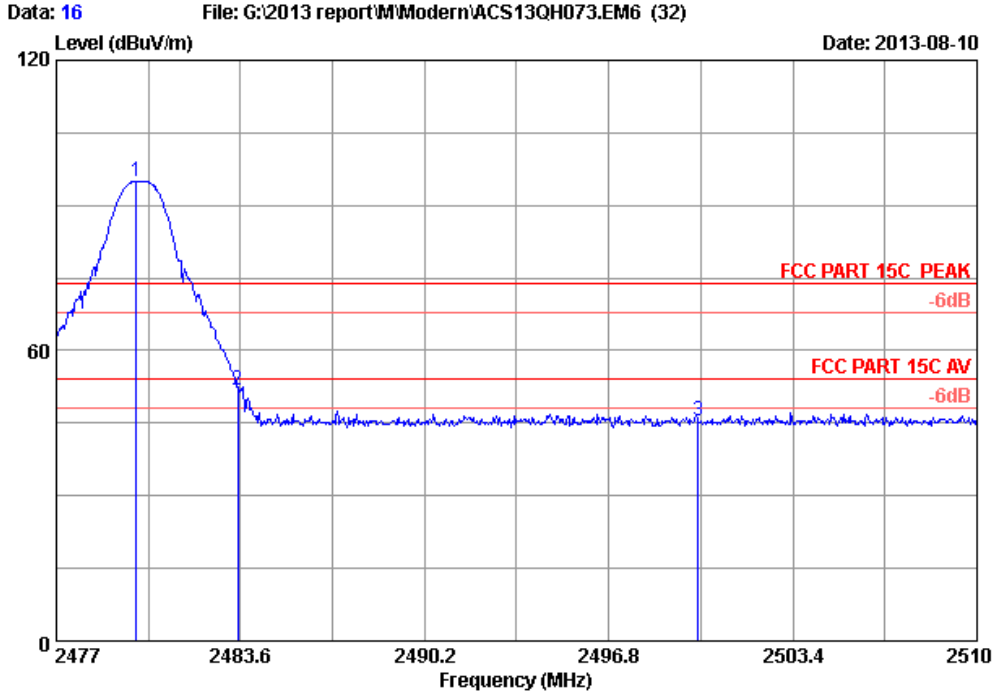

Site no. : 3m Chamber Data no. : 16
 Dis. / Ant. : 3m 2012 3115 (4580) Ant. pol. : HORIZONTAL
 Limit : FCC PART 15C PEAK
 Env. / Ins. : 23°C/54% Engineer : Leo-Li
 EUT : Universal Multi-Charging Station
 Power supply : DC 5V From Adapter Input AC 120V/60Hz
 Test mode : GFSK 2480MHz Tx
 M/N : CR13
 :

	Freq. (MHz)	Ant. Factor (dB/m)	Cable loss (dB)	Amp. Factor (dB)	Reading (dBuV)	Emission			Remark
						Level (dBuV/m)	Limits (dBuV/m)	Margin (dB)	
1	2479.871	27.27	5.91	35.70	97.52	95.00	74.00	-21.00	Peak
2	2483.500	27.29	5.92	35.70	54.45	51.96	74.00	22.04	Peak
3	2500.000	27.40	5.94	35.70	47.93	45.57	74.00	28.43	Peak

Remarks:

1. Emission Level= Antenna Factor + Cable Loss -Amp Factor + Reading.
2. The emission levels that are 20dB below the official limit are not reported.

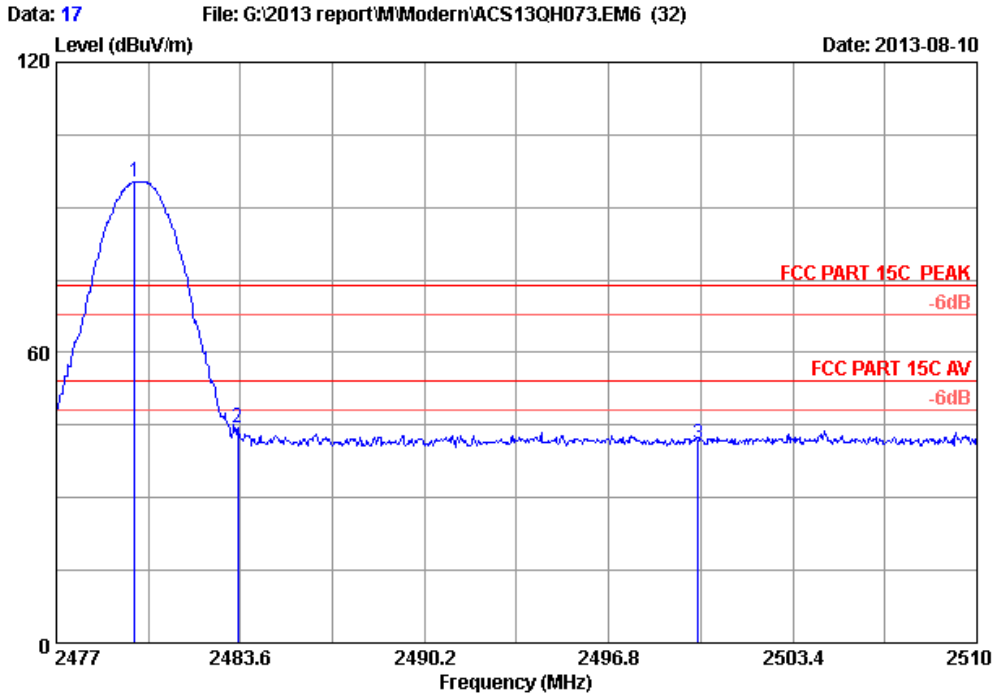

Site no. : 3m Chamber Data no. : 17
 Dis. / Ant. : 3m 2012 3115 (4580) Ant. pol. : HORIZONTAL
 Limit : FCC PART 15C PEAK
 Env. / Ins. : 23°C/54% Engineer : Leo-Li
 EUT : Universal Multi-Charging Station
 Power supply : DC 5V From Adapter Input AC 120V/60Hz
 Test mode : 8DPSK 2480MHz Tx
 M/N : CR13
 :

	Freq.	Ant.	Cable	Amp.	Emission				
	(MHz)	Factor	loss	Factor	Reading	Level	Limits	Margin	Remark
		(dB/m)	(dB)	(dB)	(dBuV)	(dBuV/m)	(dBuV/m)	(dB)	
1	2479.805	27.27	5.91	35.70	97.84	95.32	74.00	-21.32	Peak
2	2483.500	27.29	5.92	35.70	46.92	44.43	74.00	29.57	Peak
3	2500.000	27.40	5.94	35.70	43.41	41.05	74.00	32.95	Peak

Remarks:

1. Emission Level= Antenna Factor + Cable Loss -Amp Factor + Reading.
2. The emission levels that are 20dB below the official limit are not reported.

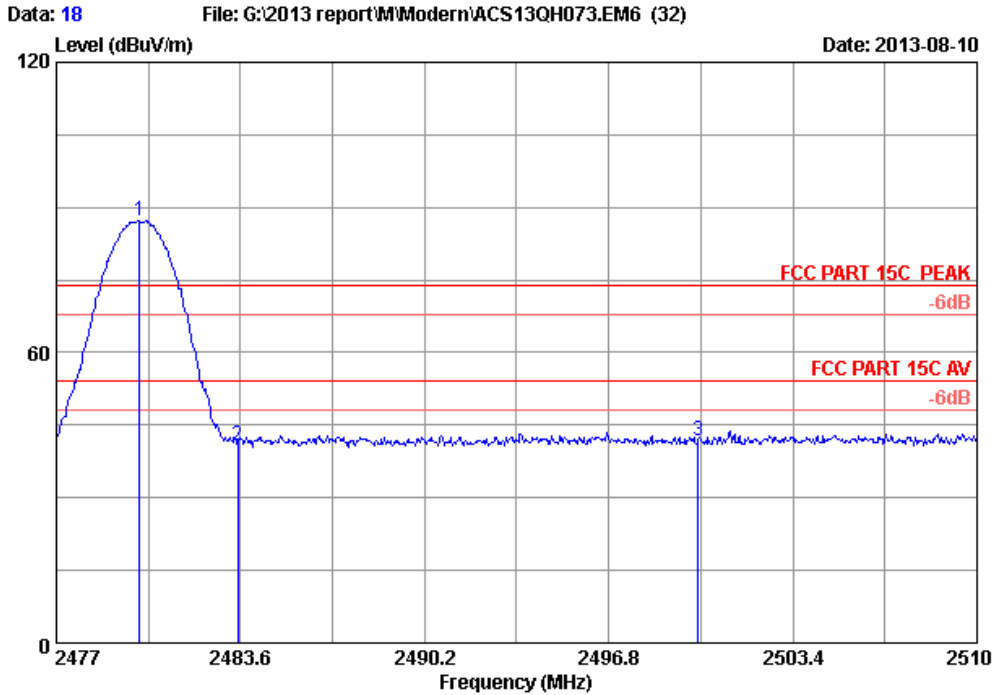

Site no. : 3m Chamber Data no. : 18
 Dis. / Ant. : 3m 2012 3115 (4580) Ant. pol. : VERTICAL
 Limit : FCC PART 15C PEAK
 Env. / Ins. : 23°C/54% Engineer : Leo-Li
 EUT : Universal Multi-Charging Station
 Power supply : DC 5V From Adapter Input AC 120V/60Hz
 Test mode : 8DPSK 2480MHz Tx
 M/N : CR13
 :

	Freq.	Ant.	Cable	Amp.	Emission				
	(MHz)	Factor	loss	Factor	Reading	Level	Limits	Margin	Remark
		(dB/m)	(dB)	(dB)	(dBuV)	(dBuV/m)	(dBuV/m)	(dB)	
1	2479.970	27.27	5.91	35.70	89.66	87.14	74.00	-13.14	Peak
2	2483.500	27.29	5.92	35.70	43.28	40.79	74.00	33.21	Peak
3	2500.000	27.40	5.94	35.70	44.12	41.76	74.00	32.24	Peak

Remarks:

1. Emission Level= Antenna Factor + Cable Loss -Amp Factor + Reading.
2. The emission levels that are 20dB below the official limit are not reported.

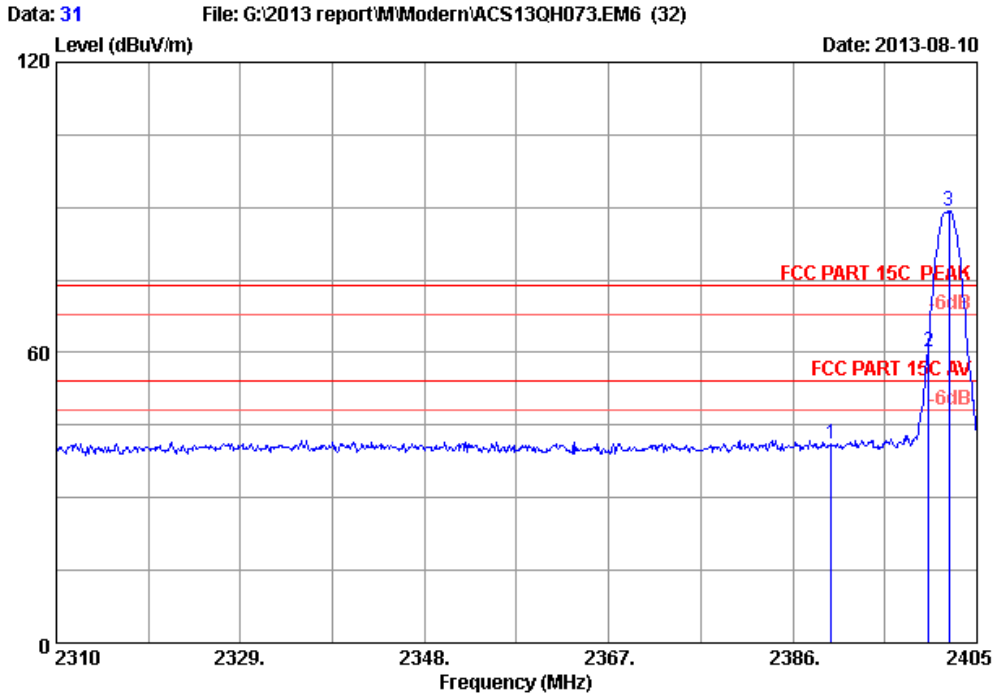

Site no. : 3m Chamber Data no. : 31
 Dis. / Ant. : 3m 2012 3115 (4580) Ant. pol. : VERTICAL
 Limit : FCC PART 15C PEAK
 Env. / Ins. : 23°C/54% Engineer : Leo-Li
 EUT : Universal Multi-Charging Station
 Power supply : DC 5V From Adapter Input AC 120V/60Hz
 Test mode : 8DPSK 2402MHz Tx
 M/N : CR13
 :

	Freq.	Ant. Factor	Cable loss	Amp. Factor	Reading	Emission Level	Limits	Margin	Remark
	(MHz)	(dB/m)	(dB)	(dB)	(dBuV)	(dBuV/m)	(dBuV/m)	(dB)	
1	2390.000	26.70	5.78	35.70	44.46	41.24	74.00	32.76	Peak
2	2400.000	26.76	5.80	35.70	63.16	60.02	74.00	13.98	Peak
3	2402.150	26.77	5.80	35.70	92.40	89.27	74.00	-15.27	Peak

Remarks:

1. Emission Level= Antenna Factor + Cable Loss -Amp Factor + Reading.
2. The emission levels that are 20dB below the official limit are not reported.

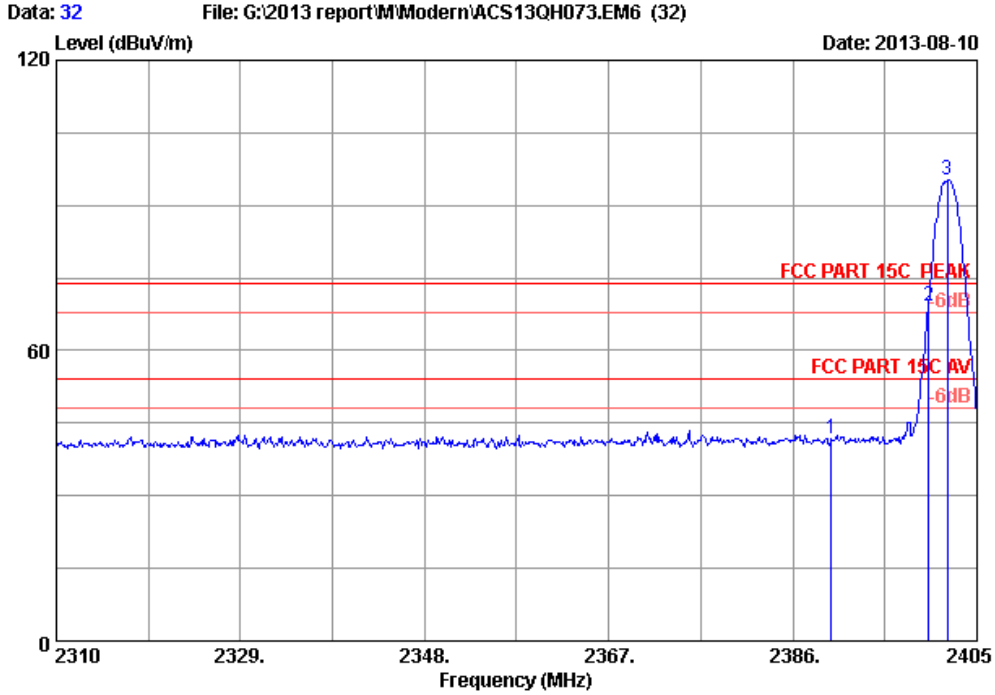

Site no. : 3m Chamber Data no. : 32
 Dis. / Ant. : 3m 2012 3115 (4580) Ant. pol. : HORIZONTAL
 Limit : FCC PART 15C PEAK
 Env. / Ins. : 23°C/54% Engineer : Leo-Li
 EUT : Universal Multi-Charging Station
 Power supply : DC 5V From Adapter Input AC 120V/60Hz
 Test mode : 8DPSK 2402MHz Tx
 M/N : CR13
 :

	Freq.	Ant. Factor	Cable loss	Amp. Factor	Reading	Emission Level	Limits	Margin	Remark
	(MHz)	(dB/m)	(dB)	(dB)	(dBuV)	(dBuV/m)	(dBuV/m)	(dB)	
1	2390.000	26.70	5.78	35.70	45.09	41.87	74.00	32.13	Peak
2	2400.000	26.76	5.80	35.70	72.41	69.27	74.00	4.73	Peak
3	2401.960	26.77	5.80	35.70	98.36	95.23	74.00	-21.23	Peak

Remarks:

1. Emission Level= Antenna Factor + Cable Loss -Amp Factor + Reading.
2. The emission levels that are 20dB below the official limit are not reported.

12.DEVIATION TO TEST SPECIFICATIONS

[NONE]

13. PHOTOGRAPH OF TEST

13.1. Photos of Conducted Disturbance at Mains Terminals Test



13.2.Photos of Radiated Emission Test



(Above 1000MHz)



14.PHOTOS OF THE EUT

Figure 1
General Appearance of the EUT



Figure 2
General Appearance of the EUT



Figure 3
General Appearance of the EUT



Figure 4
General Appearance of the EUT



Figure 5
General Appearance of the EUT



Figure 6
General Appearance of the EUT



Figure 7
Inside of the EUT



Figure 8
Inside of the EUT



Figure 9
Inside of the EUT



Figure 10
Inside of the EUT



Figure 11
Inside of the EUT



Figure 12
Inside of the EUT



Figure 13
Inside of the EUT



Figure 14
Inside of the EUT



Figure 15
Inside of the EUT



Figure 16
Inside of the EUT

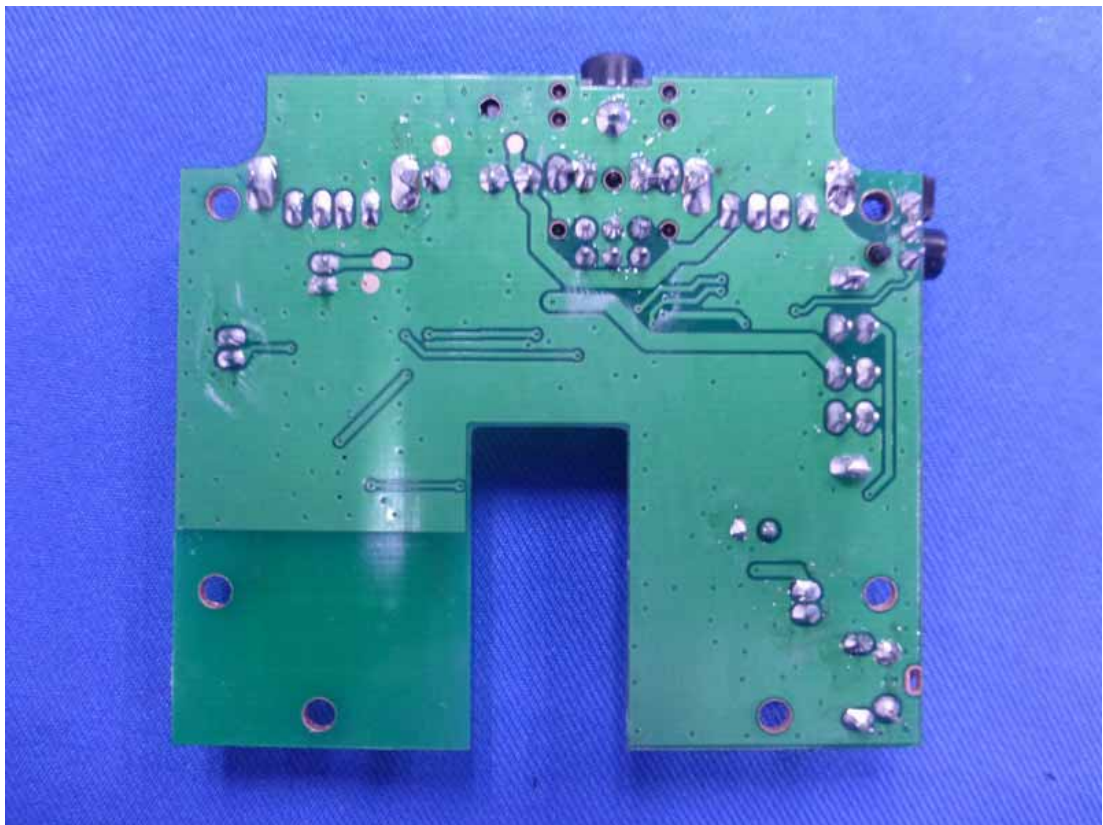

Figure 17
Inside of the EUT

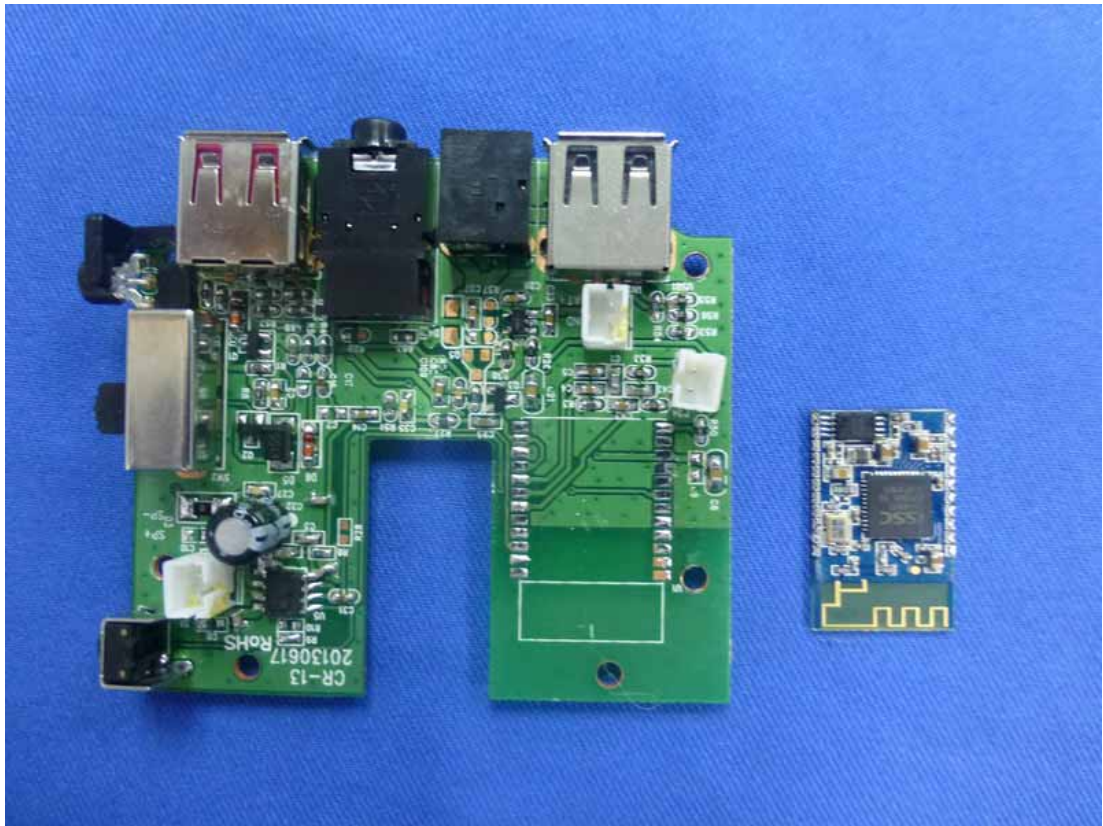

Figure 18
Inside of the EUT



Figure 19
Inside of the EUT

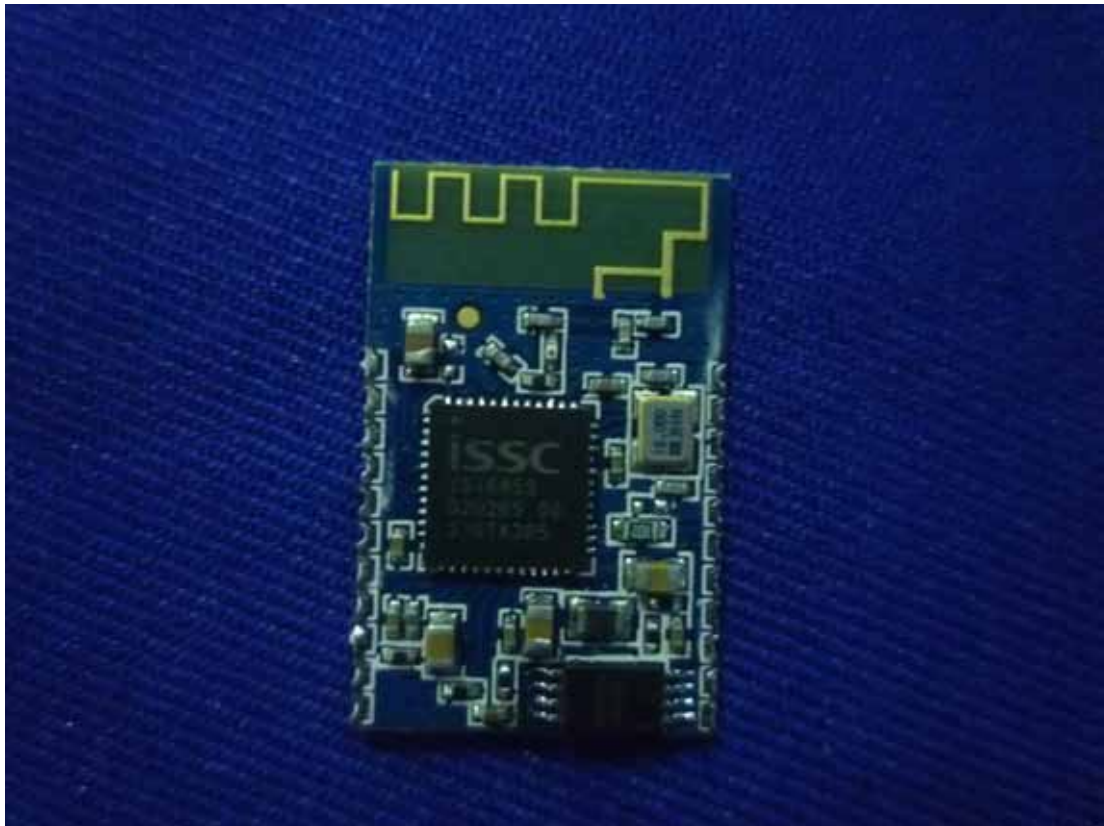

Figure 20
Inside of the EUT

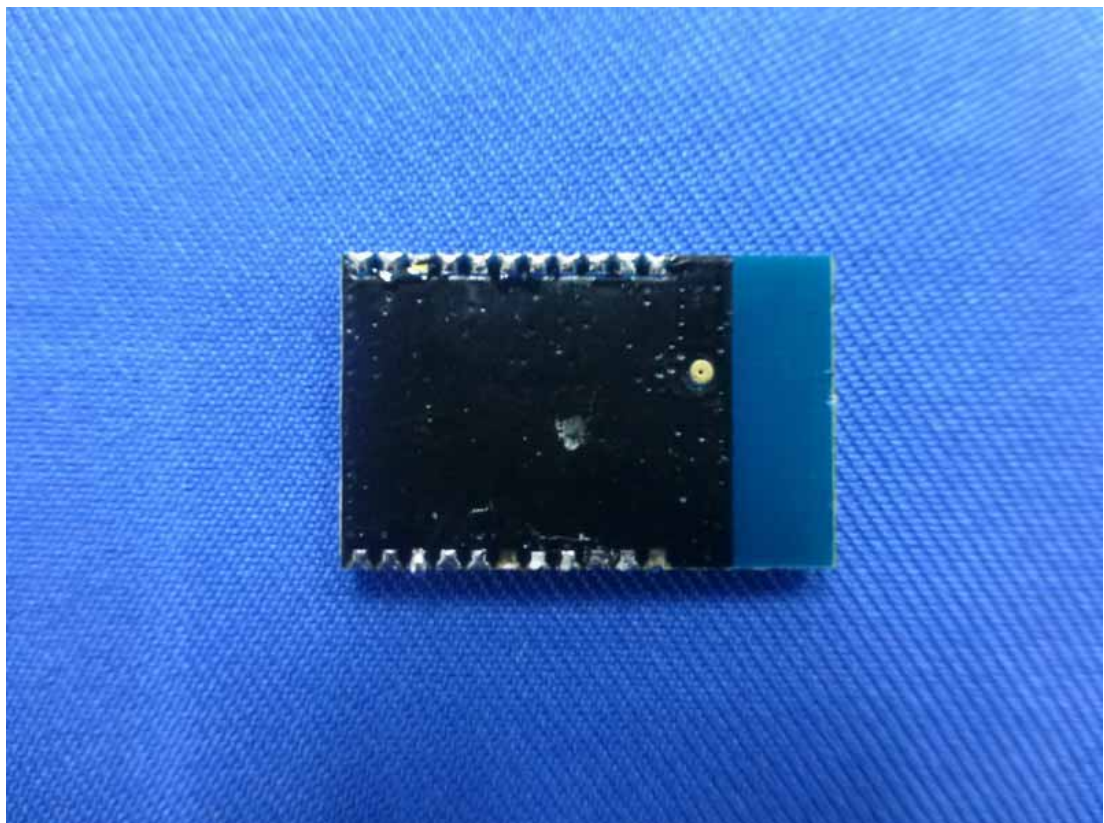

Figure 21
Speaker



Figure 22
Speaker

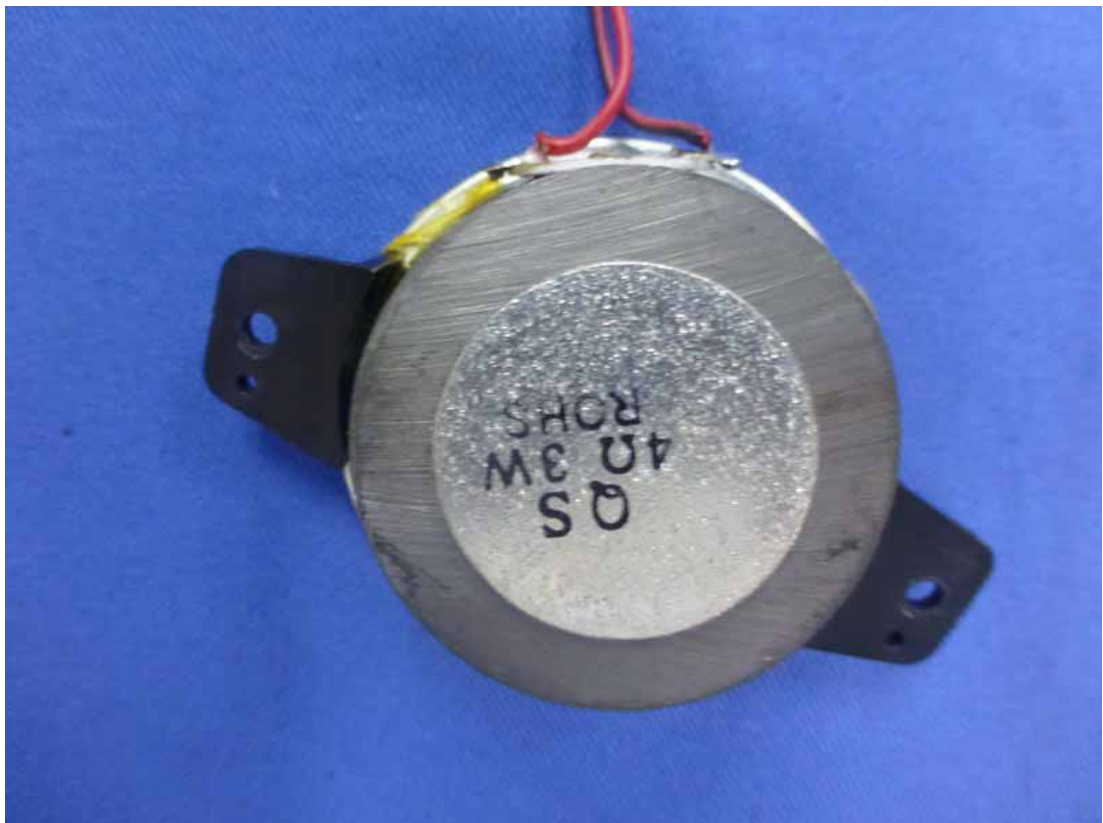

Figure 23
Power Adapter



Figure 24
Power Adapter



Figure 25
Power Adapter



Figure 26
Power Adapter



Figure 27
USB Cable



Figure 28
Audio Cable

