

STRYKER ENDOSCOPY

SYNK RECEIVER

Model: P23366



Jan 7th, 2013

Report No.: SL12011902-STR-001_SYNK_Receiver (DFS)
(This report supersedes: None)



Modifications made to the product : None

This Test Report is Issued Under the Authority of:

	
Choon Sian Ooi Compliance Engineer	David Zhang Compliance Engineer

This test report may be reproduced in full only.
All Test Data Presented in this report is only applicable to presented Test sample.

RF Test Report

To: FCC15.407h DFS Test Report

SIEMIC, INC.
Accessing global markets



Laboratory Introduction

SIEMIC, headquartered in the heart of Silicon Valley, with superior facilities in US and Asia, is one of the leading independent testing and certification facilities providing customers with one-stop shop services for Compliance Testing and Global Certifications.



In addition to [testing](#) and [certification](#), SIEMIC provides initial design reviews and [compliance management](#) through out a project. Our extensive experience with [China](#), [Asia Pacific](#), [North America](#), [European](#), and [international](#) compliance requirements, assures the fastest, most cost effective way to attain regulatory compliance for the [global markets](#).

Accreditations for Conformity Assessment

Country/Region	Accreditation Body	Scope
USA	FCC, A2LA	EMC , RF/Wireless , Telecom
Canada	IC, A2LA, NIST	EMC, RF/Wireless , Telecom
Taiwan	BSMI , NCC , NIST	EMC, RF, Telecom , Safety
Hong Kong	OFTA , NIST	RF/Wireless ,Telecom
Australia	NATA, NIST	EMC, RF, Telecom , Safety
Korea	KCC/RRA, NIST	EMI, EMS, RF , Telecom, Safety
Japan	VCCI, JATE, TELEC, RFT	EMI, RF/Wireless, Telecom
Mexico	NOM, COFETEL, Caniety	Safety, EMC , RF/Wireless, Telecom
Europe	A2LA, NIST	EMC, RF, Telecom , Safety

Accreditations for Product Certifications

Country	Accreditation Body	Scope
USA	FCC TCB, NIST	EMC , RF , Telecom
Canada	IC FCB , NIST	EMC , RF , Telecom
Singapore	iDA, NIST	EMC , RF , Telecom
EU	NB	EMC & R&TTE Directive
Japan	MIC (RCB 208)	RF , Telecom
HongKong	OFTA (US002)	RF , Telecom



SIEMIC, INC.

Accessing global markets

Title: RF Test Report of Stryker Endoscopy
Model : P23366
To FCC DFS Test Report

Serial# SL12011902-STR-001_SYNK_Receiver (DFS)
Issue Date Jan 7th, 2013
Page 3 of 109
www.siemic.com

This page has been left blank intentionally.

CONTENTS

1 EXECUTIVE SUMMARY & EUT INFORMATION	6
Applicant & EUT Information.....	6
2 TECHNICAL DETAILS	7
EUT Test Mode Evaluation.....	7
Supporting Equipment & Cabling.....	8
Test Software Information	8
3 REPORT REVISION HISTORY	9
4 TEST SUMMARY.....	10
Test Results Summary.....	10
5 MEASUREMENTS, EXAMINATION AND DERIVED RESULTS	11
5.1 Dynamic Frequency Selection (DFS)	11
5.1.1 RSS210 Test Procedure and Setup.....	11
5.1.2 Radar Waveform Calibration	15
5.1.3 Test Setup	22
5.1.4 DFS Test Results for channel bandwidth.....	24
ANNEX A. TEST INSTRUMENT & METHOD.....	65
Annex A.i. TEST INSTRUMENTATION & GENERAL PROCEDURES	65
ANNEX B RADAR TYPE 5 WAVEFORM CHARACTERISTIC	66
ANNEX C. TEST SETUP AND SUPPORTING EQUIPMENT	79
EUT TEST CONDITIONS.....	79
Annex C. i. SUPPORTING EQUIPMENT DESCRIPTION.....	79
Annex C.ii. EUT OPERATING CONDITIONS.....	80
ANNEX D USER MANUAL, BLOCK DIAGRAM, CIRCUIT DIAGRAM	81
ANNEX E SIEMIC ACCREDITATION	82



SIEMIC, INC.

Accessing global markets

Title: RF Test Report of Stryker Endoscopy
Model : P23366
To FCC DFS Test Report

Serial# SL12011902-STR-001_SYNK_Receiver (DFS)
Issue Date Jan 7th, 2013
Page 5 of 109
www.siemic.com

This page has been left blank intentionally.

1 Executive Summary & EUT information

The purpose of this test programme was to demonstrate compliance of the Stryker Endoscopy, SYNK Receiver, and Model: P23366 against the current Stipulated Standards. The SYNK Receiver has demonstrated compliance with the FCC15.407h, FCC 06-96 & IC RSS210 Issue 8: 2010.

Applicant & EUT Information

Applicant Information

Applicant / Client	Stryker Endoscopy 5900 Optical Court, San Jose, California 95138 U.S.A
Manufacturer1	Stryker Endoscopy 5900 Optical Court, San Jose, California 95138 U.S.A

EUT Information

EUT Description	:	SYNK Receiver
Model Name	:	P23366
Serial No	:	N/A
Input Power	:	100-240VAC, 50-60Hz (External Power Adapter Input) 12VDC, 1.5A (External Power Adapter Output)
Frequency	:	5260~5320MHz (20MHz bandwidth), 5500~5700MHz (20MHz bandwidth)
Radiated power	:	7.26 dBm EIRP
Modulation	:	OFDM
Classification Per Stipulated Test Standard	:	UNII

2 TECHNICAL DETAILS

Laboratory performing the tests	SIEMIC Laboratories 775 Montague Expressway, Milpitas, CA 95035
Date of EUT received	Sep 10th, 2012
Dates of test (from – to)	Oct 18 th , 2012 – Jan 7 th , 2013
Equipment Category	UNII
Standard applied	See page 2
FCC ID:	SSH-SYNKRX
IC ID:	4919C-SYNKRX

EUT Test Mode Evaluation

EUT Major Function List

Functions	Description
Fn#1	Wireless communication

EUT Test Mode List

RF Test Modes	Description	Test Configuration
RF_Test Mode	TTE test software	Continues Tx

5150~5350MHz		5470~5725MHz	
Channel	Frequency (MHz)	Channel	Frequency (MHz)
1	5180	9	5500
2	5200	10	5520
3	5220	11	5540
4	5240	12	5560
5	5260	13	5580
6	5280	14	5660
7	5300	15	5680
8	5320	16	5700

5725~5825MHz	
Channel	Frequency (MHz)
17	5745
18	5765
19	5785
20	5805
21	5825

Supporting Equipment & Cabling

Supporting equipment used with the EUT

Equipment Description	Model	Serial No.	Manufacturer
Power Supply	MW170KB1203F01	N/A	Medical Power Supply
PC Laptop / HP	N/A	N/A	Stryker Endoscopy
WISE 26" HDTV Display	VHW26110620	N/A	Stryker Endoscopy
SYNK Transmitter	0240031010	N/A	Stryker Endoscopy
Multimedia Generator	ODSG-02C	N/A	Spider

Details of cables between EUT and Supporting Equipment

Connection Start		Connection Stop		Length / shielding Info	
From	I/O Port	To	I/O Port	Length(m)	Shielding
Power Supply	Power	EUT	Power	0.5	shielded
PC Laptop / HP	Serial	EUT	Serial	0.5	N/A
WISE 26" HDTV Display	DVI	EUT	DVI	0.5	N/A
SYNK Transmitter	RF	EUT	RF	3	N/A
Multimedia Generator	Serial	SYNK Transmitter	Serial	0.5	N/A

Test Software Information

Test Item	Software	Description
DFS	TTE test software	Set the EUT to different modulation and channel



SIEMIC, INC.

Accessing global markets

Title: RF Test Report of Stryker Endoscopy
Model : P23366
To FCC DFS Test Report

Serial# SL12011902-STR-001_SYNK_Receiver (DFS)
Issue Date Jan 7th, 2013
Page 9 of 109
www.siemic.com

3 REPORT REVISION HISTORY

Report No.	Report Version	Description	Issue Date
SL12011902-STR-001_SYNK_Receiver (DFS)	Original	None	10/22/2012

4 TEST SUMMARY

The product was tested in accordance with the following specifications. All testing has been performed according to below product classification:

UNII

Test Results Summary

Test Section	Test Items	Description	Condition	Result
7.8.1	Detection Bandwidth	UNII Detection Bandwidth	Conducted	Complies
7.8.2.1	Initial Channel Availability	Initial Channel Availability Check Time	Conducted	Complies
7.8.2.2		Radar Burst at the Beginning of the Channel Availability Check Time	Conducted	Complies
7.8.2.3		Radar Burst at the End of the Channel Availability Check Time	Conducted	Complies
7.8.3	In-Service Monitoring	In-Service Monitoring for Channel Move Time, Channel Closing Transmission Time and Non-Occupancy Period	Conducted	Complies
7.8.4	Radar Detection Probability	Statistical Performance Check	Conducted	Complies
	Uniform spreading	The spreading of U-NII device Operating Channels over the 5250-5350 MHz and/or 5470-5725 MHz bands to avoid dense clusters of devices operating on the same Channel.	Declared by Manufacturer	Complies

Note: EUT supports different data rates and multiple channels, only the worse case test result with maximum data rates at Low, Mid, High channels are presented in this report.

5 MEASUREMENTS, EXAMINATION AND DERIVED RESULTS

5.1 Dynamic Frequency Selection (DFS)

5.1.1 RSS210 Test Procedure and Setup

Interference Threshold values, Master or Client incorporating In-Service Monitoring

Maximum Transmit Power	Value (see note)
≥ 200 milliwatt	-64 dBm
< 200 milliwatt	-62 dBm
<p>Note 1: This is the level at the input of the receiver assuming a 0 dBi receive antenna Note 2: Throughout these test procedures an additional 1 dB has been added to the amplitude of the test transmission waveforms to account for variations in measurement equipment. This will ensure that the test signal is at or above the detection threshold level to trigger a DFS response.</p>	

DFS Response requirement values

Parameter	Value
<i>Non-occupancy period</i>	Minimum 30 minutes
<i>Channel Availability Check Time</i>	60 seconds
<i>Channel Move Time</i>	10 seconds See Note 1.
<i>Channel Closing Transmission Time</i>	200 milliseconds + an aggregate of 60 milliseconds over remaining 10 second period. See Notes 1 and 2.
<i>U-NII Detection Bandwidth</i>	Minimum 80% of the 99% power bandwidth See Note 3.

Note 1: The instant that the *Channel Move Time* and the *Channel Closing Transmission Time* begins is as follows: • For the Short pulse radar Test Signals this instant is the end of the *Burst*. • For the Frequency Hopping radar Test Signal, this instant is the end of the last radar *Burst* generated. • For the Long Pulse radar Test Signal this instant is the end of the 12 second period defining the radar transmission. Note 2: The *Channel Closing Transmission Time* is comprised of 200 milliseconds starting at the beginning of the *Channel Move Time* plus any additional intermittent control signals required facilitating *Channel* changes (an aggregate of 60 milliseconds) during the remainder of the 10 second period. The aggregate duration of control signals will not count quiet periods in between transmissions. Note 3: During the *U-NII Detection Bandwidth* detection test, radar type 1 is used and for each frequency step the minimum percentage of detection is 90%. Measurements are performed with no data traffic.

Radar Test Waveforms

This section provides the parameters for required test waveforms, minimum percentage of successful detections, and the minimum number of trials that must be used for determining DFS conformance. Step intervals of 0.1 microsecond for Pulse Width, 1 microsecond for PRI, 1 MHz for chirp width and 1 for the number of pulses will be utilized for the random determination of specific test waveforms

1. Short Pulse Radar Test Waveforms

Radar Type	Pulse Width (µsec)	PRI (µsec)	Number of Pulses	Minimum Percentage of Successful Detection	Minimum Trials
1	1	1428	18	60%	30
2	1-5	150-230	23-29	60%	30
3	6-10	200-500	16-18	60%	30
4	11-20	200-500	12-16	60%	30
Aggregate (Radar Types 1-4)				80%	120

2. Long Pulse Radar Test Waveform

Radar Type	Pulse Width (µsec)	Chirp Width (MHz)	PRI (µsec)	Number of Pulses per Burst	Number of Bursts	Minimum Percentage of Successful Detection	Minimum Trials
5	50-100	5-20	1000-2000	1-3	8-20	80%	30

The parameters for this waveform are randomly chosen. Thirty unique waveforms are required for the Long Pulse radar test signal. If more than 30 waveforms are used for the Long Pulse radar test signal, then each additional waveform must also be unique and not repeated from the previous waveforms.

Each waveform is defined as follows:

1) The transmission period for the Long Pulse Radar test signal is 12 seconds. 2) There are a total of 8 to 20 Bursts in the 12 second period, with the number of Bursts being randomly chosen. This number is Burst_Count. 3) Each Burst consists of 1 to 3 pulses, with the number of pulses being randomly chosen. Each Burst within the 12 second sequence may have a different number of pulses.

4) The pulse width is between 50 and 100 microseconds, with the pulse width being randomly chosen. Each pulse within a Burst will have the same pulse width. Pulses in different Bursts may have different pulse widths.

5) Each pulse has a linear FM chirp between 5 and 20 MHz, with the chirp width being randomly chosen. Each pulse within a Burst will have the same chirp width. Pulses in different Bursts may have different chirp widths. The chirp is centered on the pulse. For example, with a radar frequency of 5300 MHz and a 20 MHz chirped signal, the chirp starts at 5290 MHz and ends at 5310 MHz.

6) If more than one pulse is present in a Burst, the time between the pulses will be between 1000 and 2000 microseconds, with the time being randomly chosen. If three pulses are present in a Burst, the time between the first and second pulses is chosen independently of the time between the second and third pulses.

7) The 12 second transmission period is divided into even intervals. The number of intervals is equal to Burst_Count. Each interval is of length $(12,000,000 / \text{Burst_Count})$ microseconds. Each interval contains one Burst. The start time for the Burst, relative to the beginning of the interval, is between 1 and $[(12,000,000 / \text{Burst_Count}) - (\text{Total Burst Length}) + (\text{One Random PRI Interval})]$ microseconds, with the start time being randomly chosen. The step interval for the start time is 1 microsecond. The start time for each Burst is chosen independently.

A representative example of a Long Pulse radar test waveform:

1) The total test signal length is 12 seconds. 2) 8 Bursts are randomly generated for the Burst Count. 3) Burst 1 has 2 randomly generated pulses. 4) The pulse width (for both pulses) is randomly selected to be 75 microseconds. 5) The PRI is randomly selected to be at 1213 microseconds. 6) Bursts 2 through 8 are generated using steps 3 – 5. 7) Each Burst is contained in even intervals of 1,500,000 microseconds. The starting location for Pulse 1, Burst 1 is randomly generated (1 to 1,500,000 minus the total Burst 1 length + 1 random PRI interval) at the 325,001 microsecond step. Bursts 2 through 8 randomly fall in successive 1,500,000 microsecond intervals (i.e. Burst 2 falls in the 1,500,001 – 3,000,000 microsecond range).

Long Pulse Radar Test Signal Waveform
12 Second Transmission

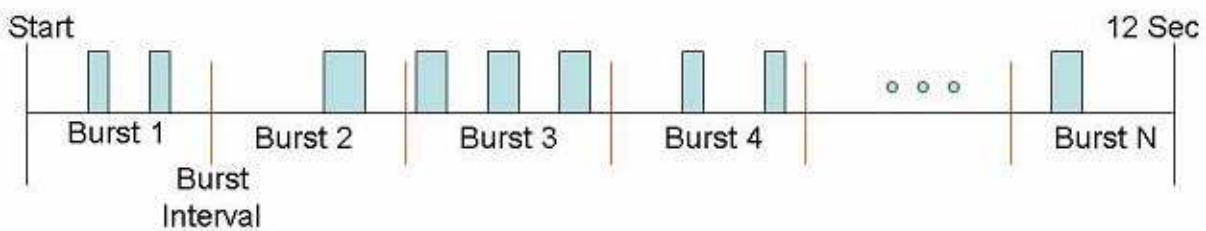

3. Frequency Hopping Radar Type

Radars Type	Pulse Width (µsec)	PRI (µsec)	Pulses per Hop	Hopping Rate (kHz)	Hopping Sequence Length (msec)	Minimum Percentage of Successful Detection	Minimum Trials
6	1	333	9	.333	300	70%	30

For the Frequency Hopping Radar Type, the same Burst parameters are used for each waveform. The hopping sequence is different for each waveform and a 100-length segment is selected 1 from the hopping sequence defined by the following algorithm:

The first frequency in a hopping sequence is selected randomly from the group of 475 integer frequencies from 5250 – 5724 MHz. Next, the frequency that was just chosen is removed from the group and a frequency is randomly selected from the remaining 474 frequencies in the group. This process continues until all 475 frequencies are chosen for the set. For selection of a random frequency, the frequencies remaining within the group are always treated as equally likely

5.1.2 Radar Waveform Calibration

The following equipment setup was used to calibrate the conducted Radar Waveform. A spectrum analyzer was used to establish the test signal level for each radar type. During this process there were no transmissions by either the Master or Client Device. The spectrum analyzer was switched to the zero span (Time Domain) mode at the frequency of the Radar Waveform generator. Peak detection was utilized. The spectrum analyzer resolution bandwidth (RBW) and video bandwidth (VBW) were set to 3 MHz.

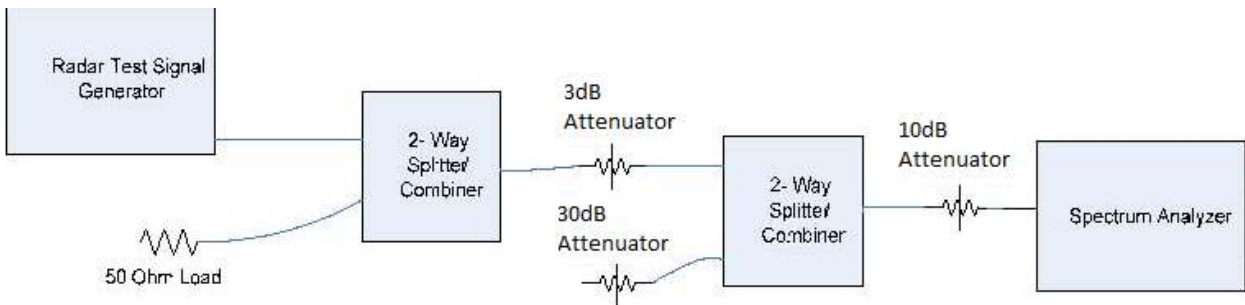

Conducted Calibration Setup

5250MHz to 5350MHz bands

Radar Type 1

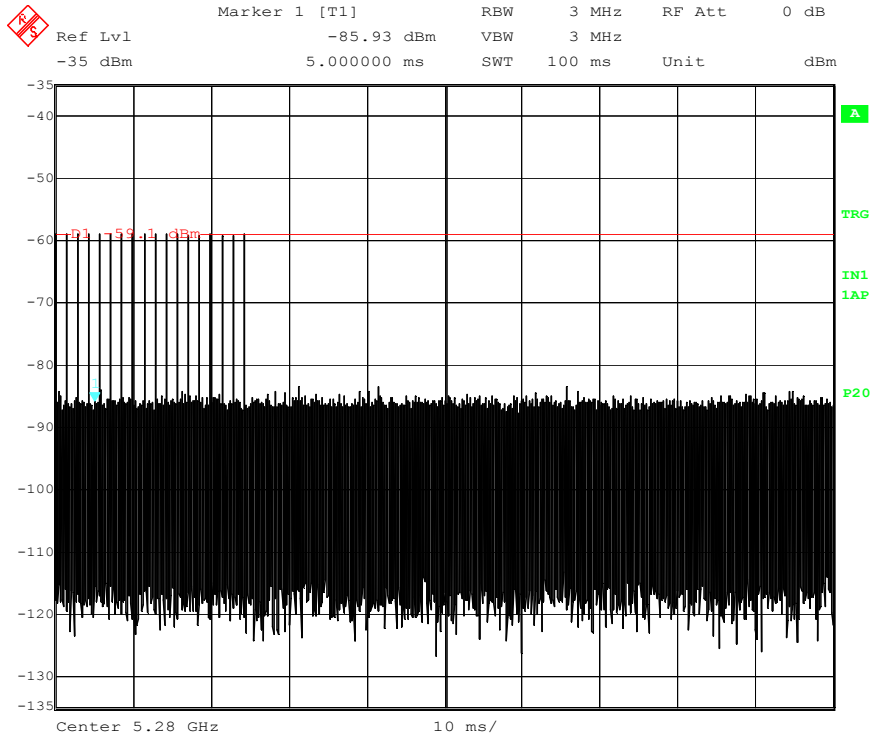

Radar Type 2

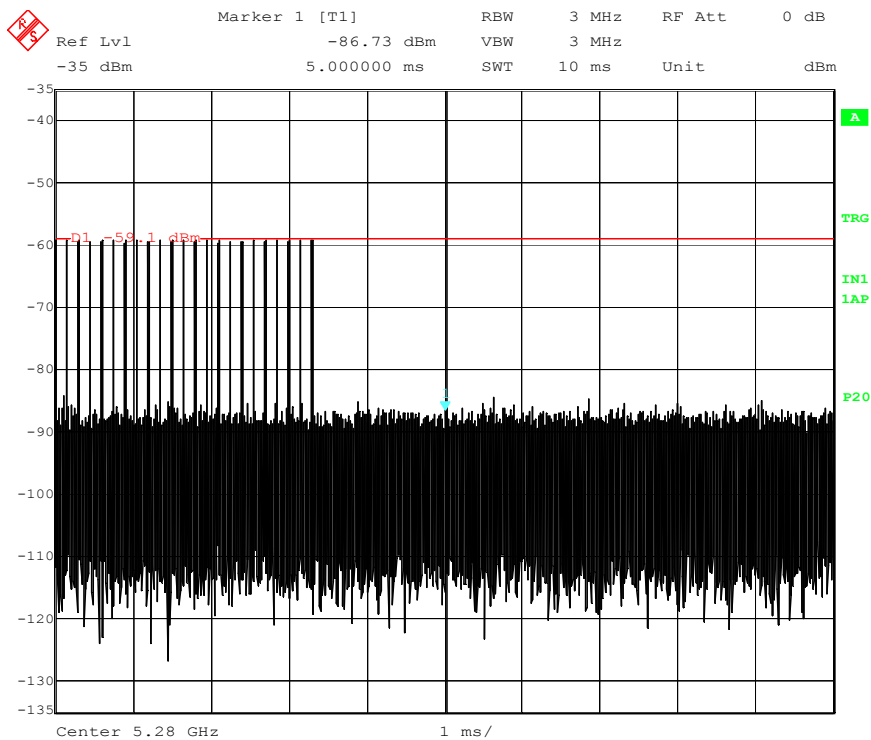

Radar Type 3

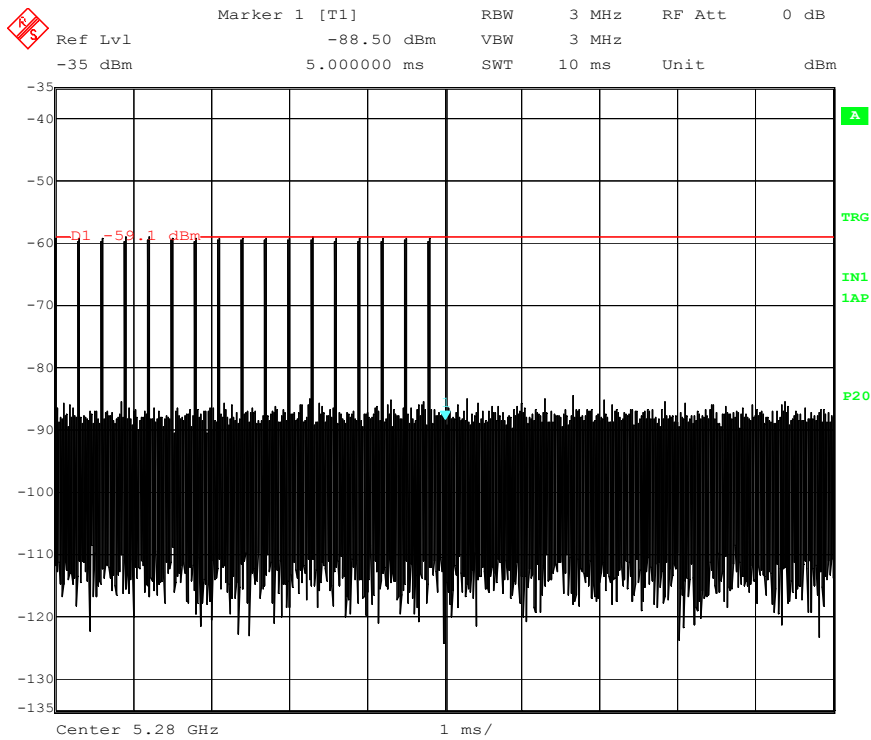

Radar type 4

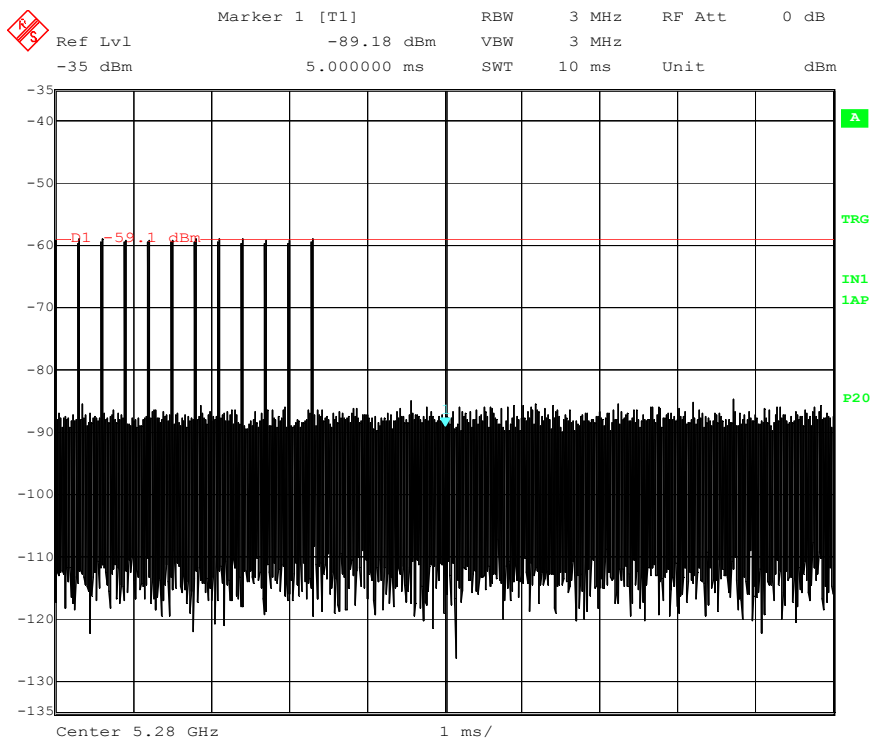



SIEMIC, Inc.

Accessing global markets

Title: RF Test Report of Stryker Endoscopy
Model : P23366
To: FCC DFS Test Report

Serial# SL12011902-STR-001_SYNK_Receiver (DFS)
Issue Date Jan 7th, 2013
Page 18 of 109
www.sieminc.com

Radar Type 5

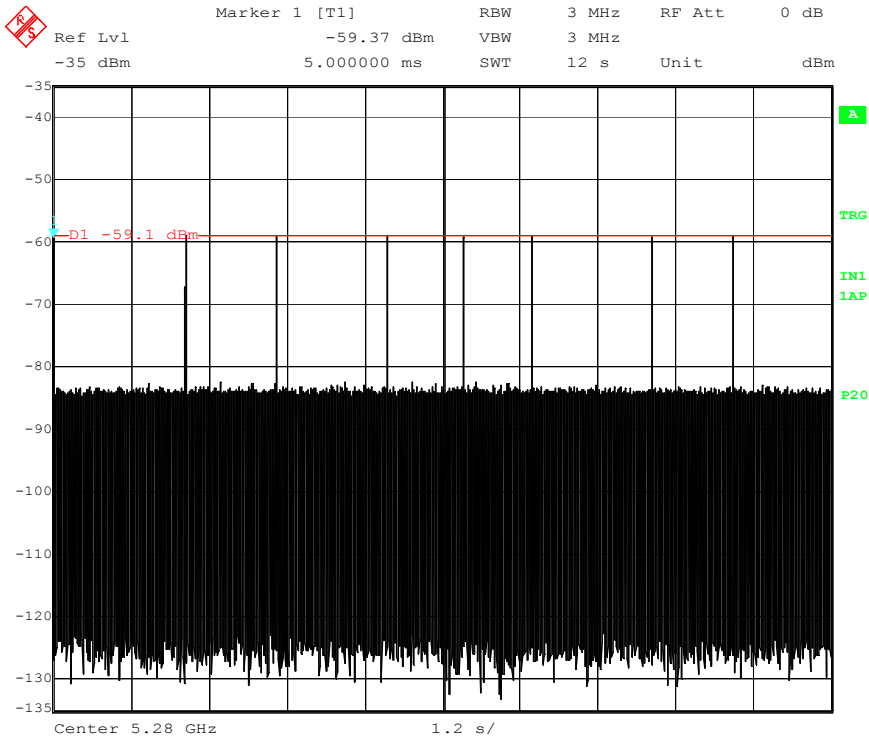

Radar Type 6

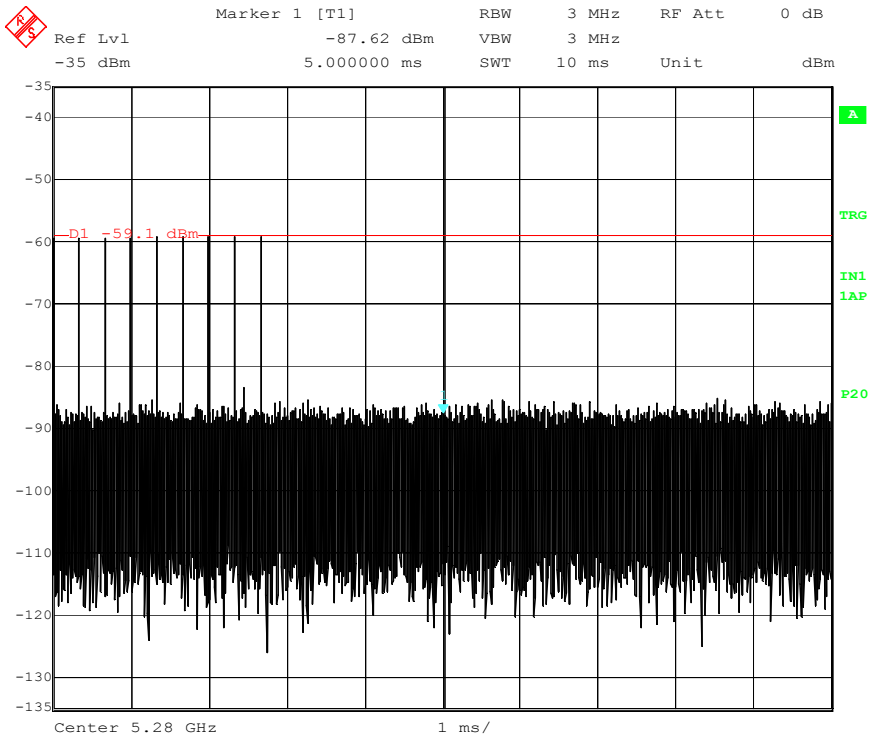

5470MHz to 5725MHz band

Radar Type 1

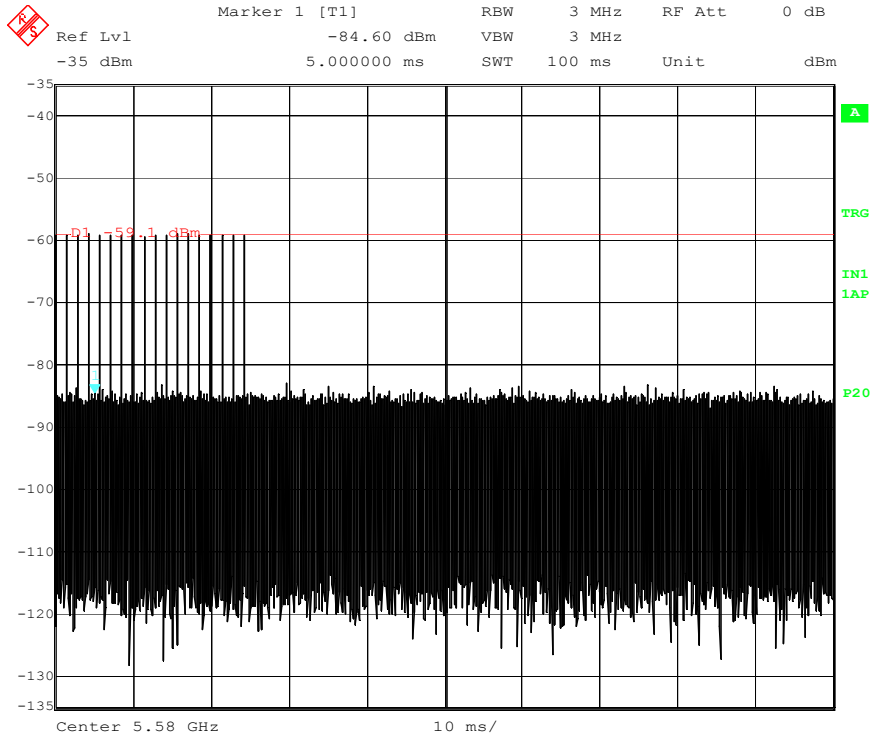

Radar Type 2

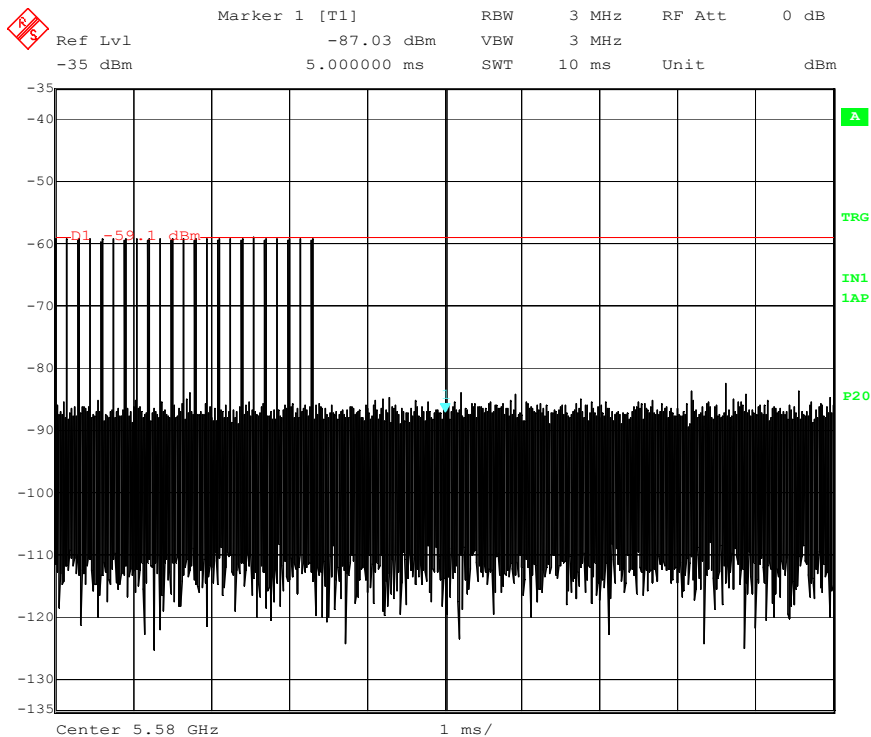

Radar Type 3

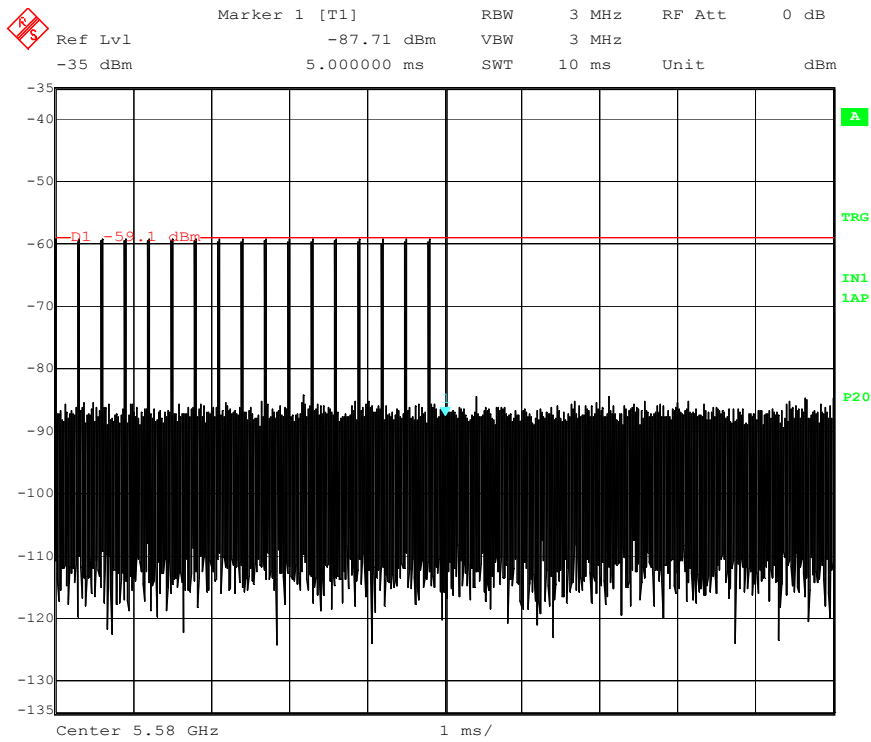

Radar Type 4

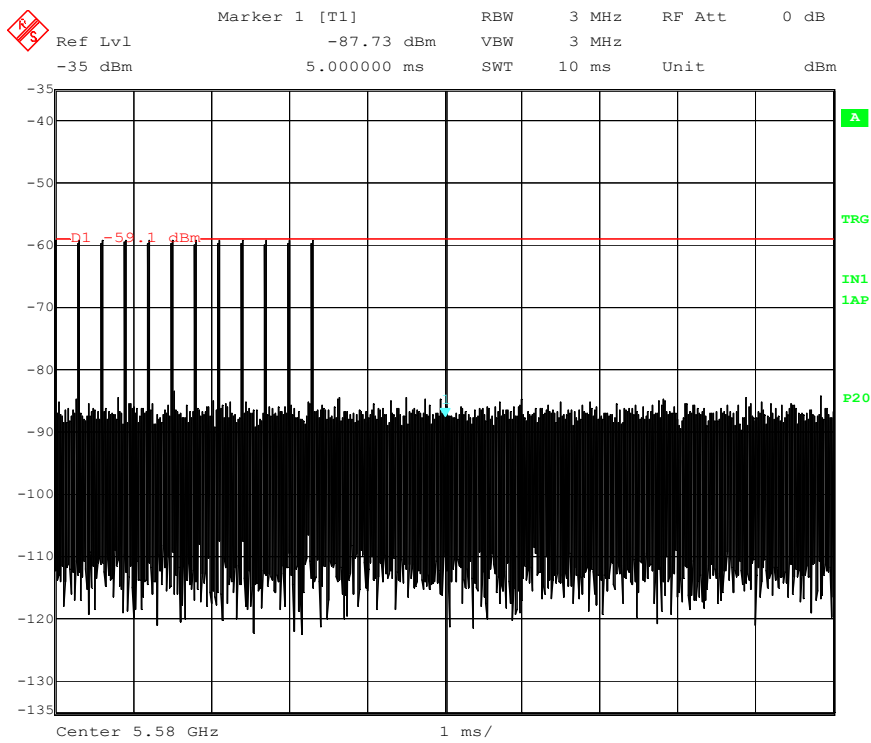

Radar Type 5

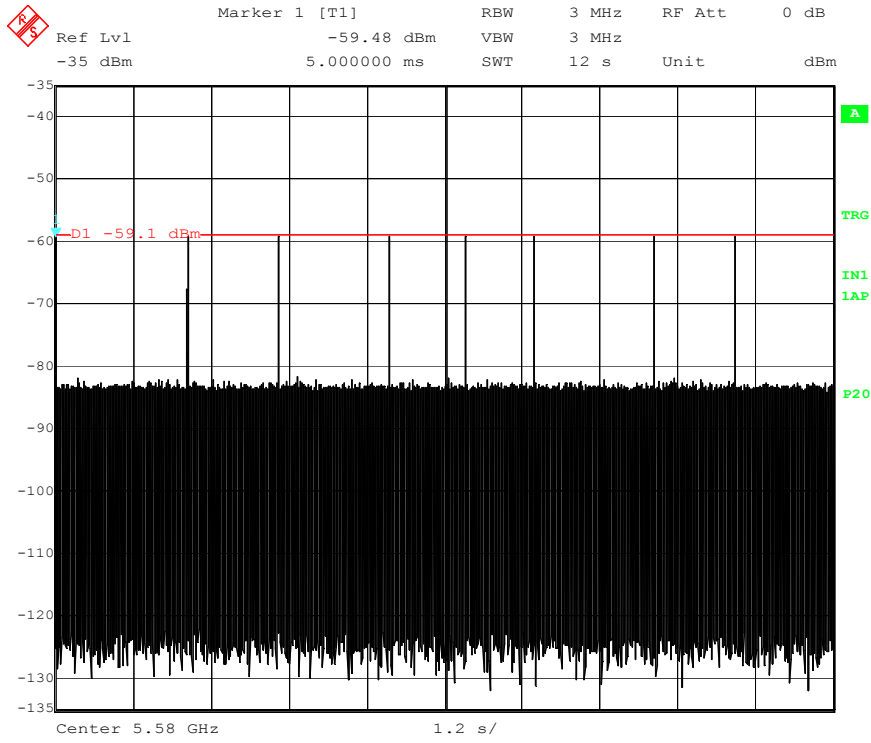

Radar Type 6

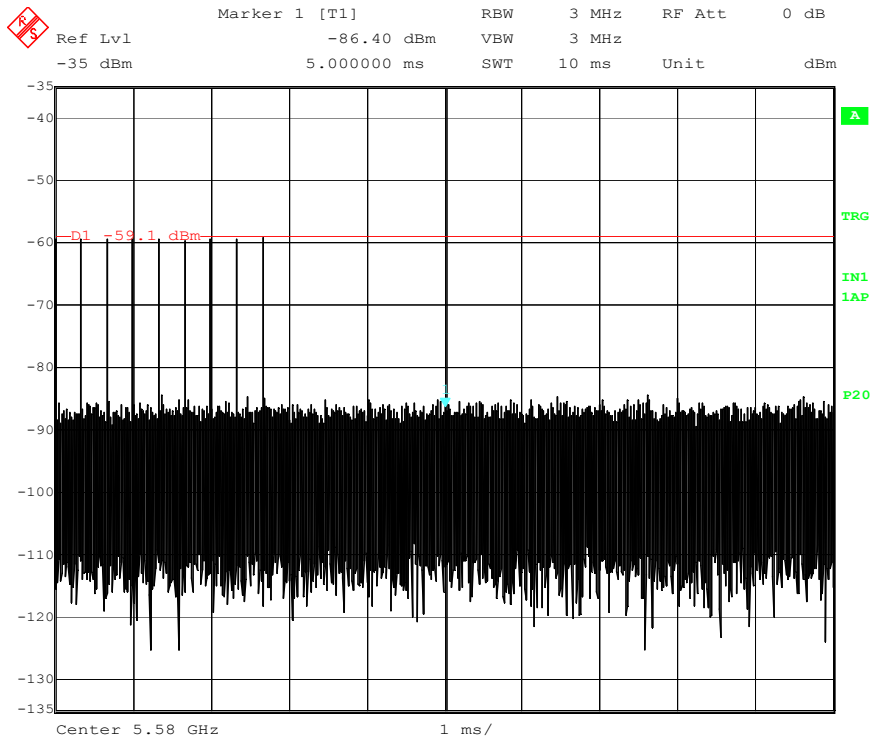

5.1.3 Test Setup

Test Setup Block Diagram

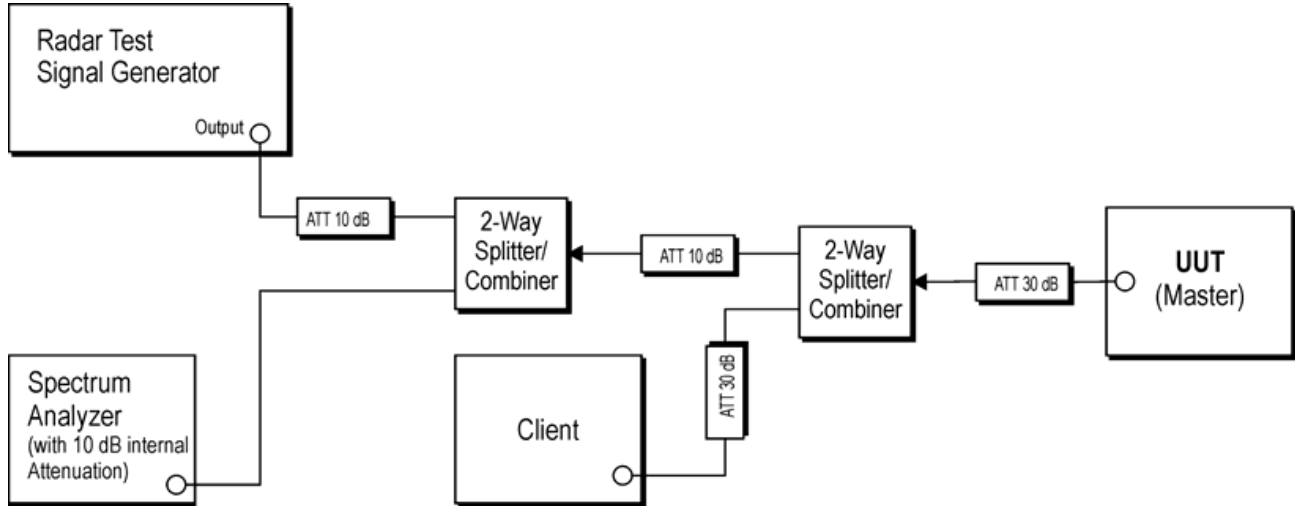

The radio was set at the center channel frequency of tested Channel.

For the frequency bands 5470MHz to 5725MHz and 5250MHz to 5350MHz the master device provides, on aggregate, uniform loading of the spectrum across all devices by selecting an operating channel among the available channels using a random algorithm.

Manufacturer declared a minimum gain antenna of 1.9dBi. ;

Radar receive signal level=-62 Bm + minimum antenna gain +1dB

=-62 +1.9 +1 Radar receive signal level = -59.1dBm

5.1.4 DFS Test Results for channel bandwidth

UNII Detection Bandwidth

UNII Detection Bandwidth: All UNII channels for this device have identical Channel bandwidths and testing was performed on Mid Channel

The generating equipment is configured as shown in the Conducted Test Setup above. A single *Burst* of the short pulse radar type 1 is produced at Mid Channel at a -59.1dBm level. The UUT is set up to connect ed to client (no traffic).

A single radar Burst is generated for a minimum of 10 trials, and the response of the UUT is noted. The UUT must detect the Radar Waveform 90% or more of the time.

The radar frequency is increased in 1 MHz steps, repeating the above test sequence, until the detection rate falls below 90%. The highest frequency at which detection is greater than or equal to 90% is denoted as F_H

The radar frequency is decreased in 1 MHz steps, repeating the above test sequence, until the detection rate falls below 90%. The lowest frequency at which detection is greater than or equal to 90% is denoted as F_L .

The U-NII Detection Bandwidth is calculated as follows:

$$\text{U-NII Detection Bandwidth} = F_H - F_L$$

The U-NII Detection Bandwidth must be at least 80% of the UUT transmitter 99% power, otherwise, the UUT does not comply with DFS requirements.

Test Result - 5250MHz to 5350MHz band

EUT Frequency = 5280MHz											
Radar Frequency (MHz)	DFS Detection Trials (1=Detection, Blank=No Detection)										Detection Rate (%)
	1	2	3	4	5	6	7	8	9	10	
5270	0	0	0	0	0	0	0	0	0	0	0
5271	1	1	1	1	1	1	1	1	1	1	1
5272	1	1	1	1	1	1	1	1	1	1	1
5273	1	1	1	1	1	1	1	1	1	1	1
5274	1	1	1	1	1	1	1	1	1	1	1
5275	1	1	1	1	1	1	1	1	1	1	1
5276	1	1	1	1	1	1	1	1	1	1	1
5277	1	1	1	1	1	1	1	1	1	1	1
5278	1	1	1	1	1	1	1	1	1	1	1
5279	1	1	1	1	1	1	1	1	1	1	1
5280	1	1	1	1	1	1	1	1	1	1	1
5281	1	1	1	1	1	1	1	1	1	1	1
5282	1	1	1	1	1	1	1	1	1	1	1
5283	1	1	1	1	1	1	1	1	1	1	1
5284	1	1	1	1	1	1	1	1	1	1	1
5285	1	1	1	1	1	1	1	1	1	1	1
5286	1	1	1	1	1	1	1	1	1	1	1
5287	1	1	1	1	1	1	1	1	1	1	1
5288	1	1	1	1	1	1	1	1	1	1	1
5289	1	1	1	1	1	1	1	1	1	1	1
5290	0	0	0	0	0	0	0	0	0	0	0
Detection Bandwidth= $F_H - F_L = 18$ MHz											
EUT 99% Bandwidth= 16.71MHz											
16.71 MHz*80%=13.37MHz											



SIEMIC, Inc.

Accessing global markets

Title: RF Test Report of Stryker Endoscopy
Model : P23366
To: FCC DFS Test Report

Serial# SL12011902-STR-001_SYNK_Receiver (DFS)
Issue Date Jan 7th, 2013
Page 26 of 109
www.sieminc.com

Test Result - 5470MHz to 5725MHz band

EUT Frequency = 5580MHz											
Radar Frequency (MHz)	DFS Detection Trials (1=Detection, Blank=No Detection)										Detection Rate (%)
	1	2	3	4	5	6	7	8	9	10	
5570	0	0	0	0	0	0	0	0	0	0	0
5571	1	1	1	1	1	1	1	1	1	1	1
5572	1	1	1	1	1	1	1	1	1	1	1
5573	1	1	1	1	1	1	1	1	1	1	1
5574	1	1	1	1	1	1	1	1	1	1	1
5575	1	1	1	1	1	1	1	1	1	1	1
5576	1	1	1	1	1	1	1	1	1	1	1
5577	1	1	1	1	1	1	1	1	1	1	1
5578	1	1	1	1	1	1	1	1	1	1	1
5579	1	1	1	1	1	1	1	1	1	1	1
5580	1	1	1	1	1	1	1	1	1	1	1
5581	1	1	1	1	1	1	1	1	1	1	1
5582	1	1	1	1	1	1	1	1	1	1	1
5583	1	1	1	1	1	1	1	1	1	1	1
5584	1	1	1	1	1	1	1	1	1	1	1
5585	1	1	1	1	1	1	1	1	1	1	1
5586	1	1	1	1	1	1	1	1	1	1	1
5587	1	1	1	1	1	1	1	1	1	1	1
5588	1	1	1	1	1	1	1	1	1	1	1
5589	1	1	1	1	1	1	1	1	1	1	1
5590	0	0	0	0	0	0	0	0	0	0	0
Detection Bandwidth= $F_H - F_L = 18$ MHz											
EUT 99% Bandwidth= 16.71MHz											
16.71 MHz*80%=13.37MHz											

Initial Channel Availability Check Time

The Initial Channel Availability Check Time tests that the UUT does not emit beacon, control, or data signals on the test Channel until the power-up sequence has been completed and the U-NII device checks for Radar Waveforms for one minute on the test Channel. This test does not use any Radar Waveforms and only needs to be performed one time.

The U-NII device is powered on and be instructed to operate at Mid Channel. At the same time the UUT is powered on, the spectrum analyzer is set to zero span mode with a 3 MHz resolution bandwidth at mid channel with a 2.5 minute sweep time.

The spectrum analyzer sweep was triggered at the same time as device started initial channel availability check time.

Test Result-5250MHz to 5350MHz band

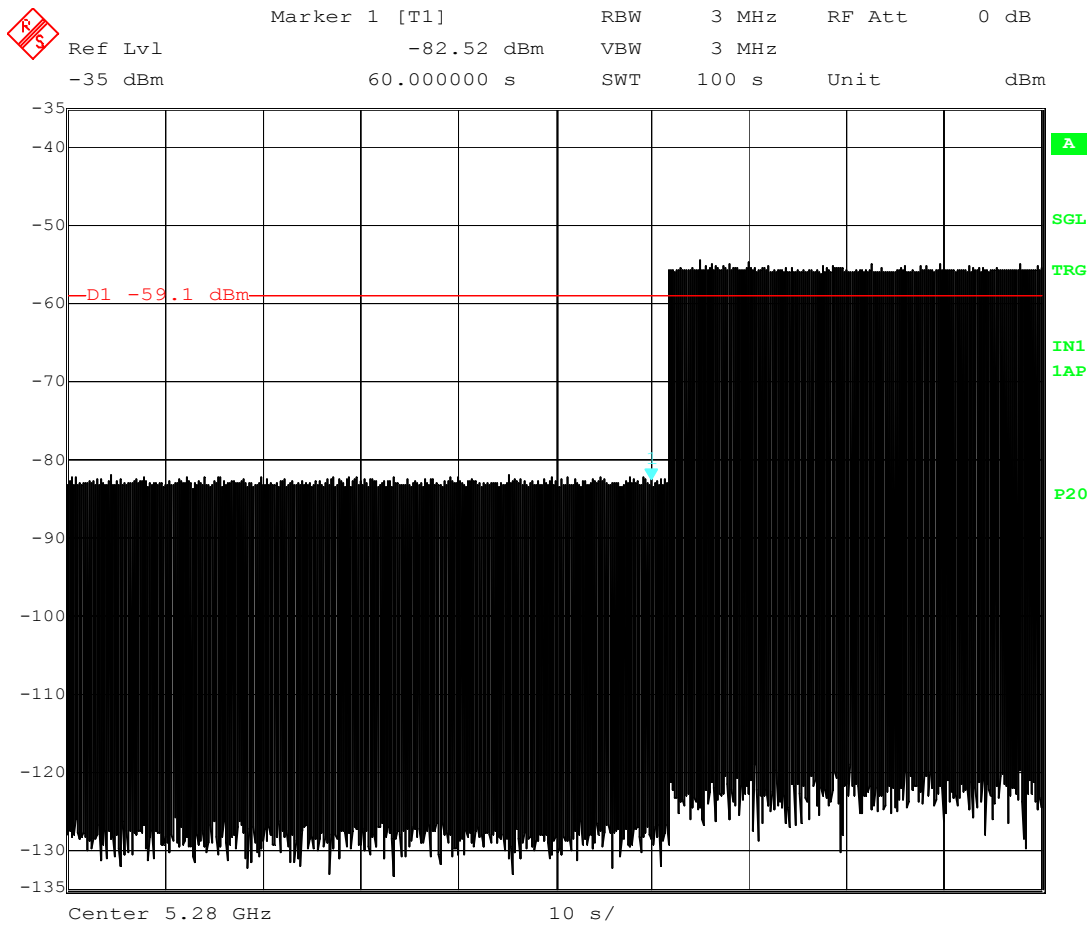

Test Result-5470MHz to 5725MHz band

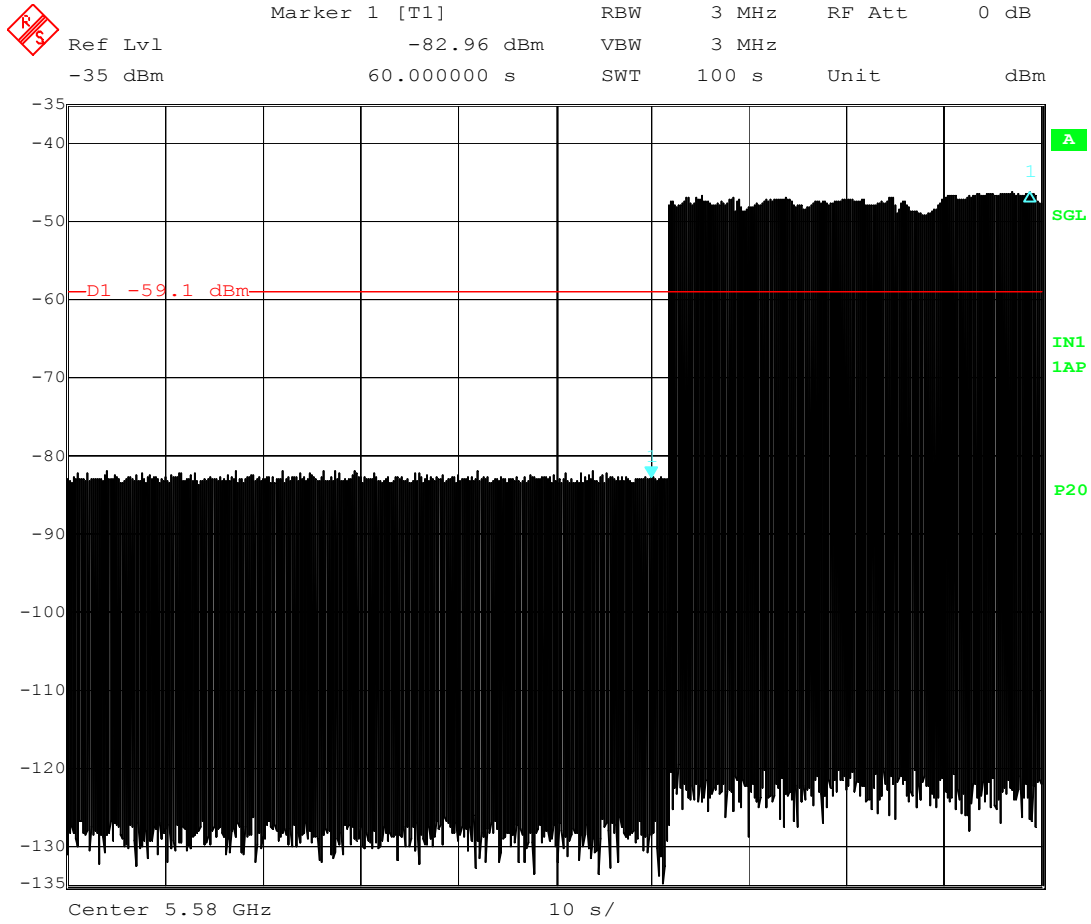

Radar Burst at the Beginning of the Channel Availability Check Time

Radar Burst at the Beginning of the Channel Availability Check Time: The steps below define the procedure to verify successful radar detection on the selected Channel during a period equal to the Channel Availability Check Time and avoidance of operation on that Channel when radar burst with a level equal to the DFS Detection Threshold + 1 dB (-59.1dBm) occurs at the beginning of the Channel Availability Check Time.

The UUT is powered on at T0. T1 denotes the instant when the UUT has completed its power-up sequence. The Channel Availability Check Time commences at instant T1 and will end no sooner than T1 + 60 seconds. A single Burst of short pulse of radar type 1 at -59.1 dBm will commence within a 6 second window.

Verify that during the 2.5 minute measurement window no UUT transmissions occurred at mid channel. Visual indication on the UUT of successful detection of the radar Burst will be recorded and reported.

Test Result-5250MHz to 5350MHz band

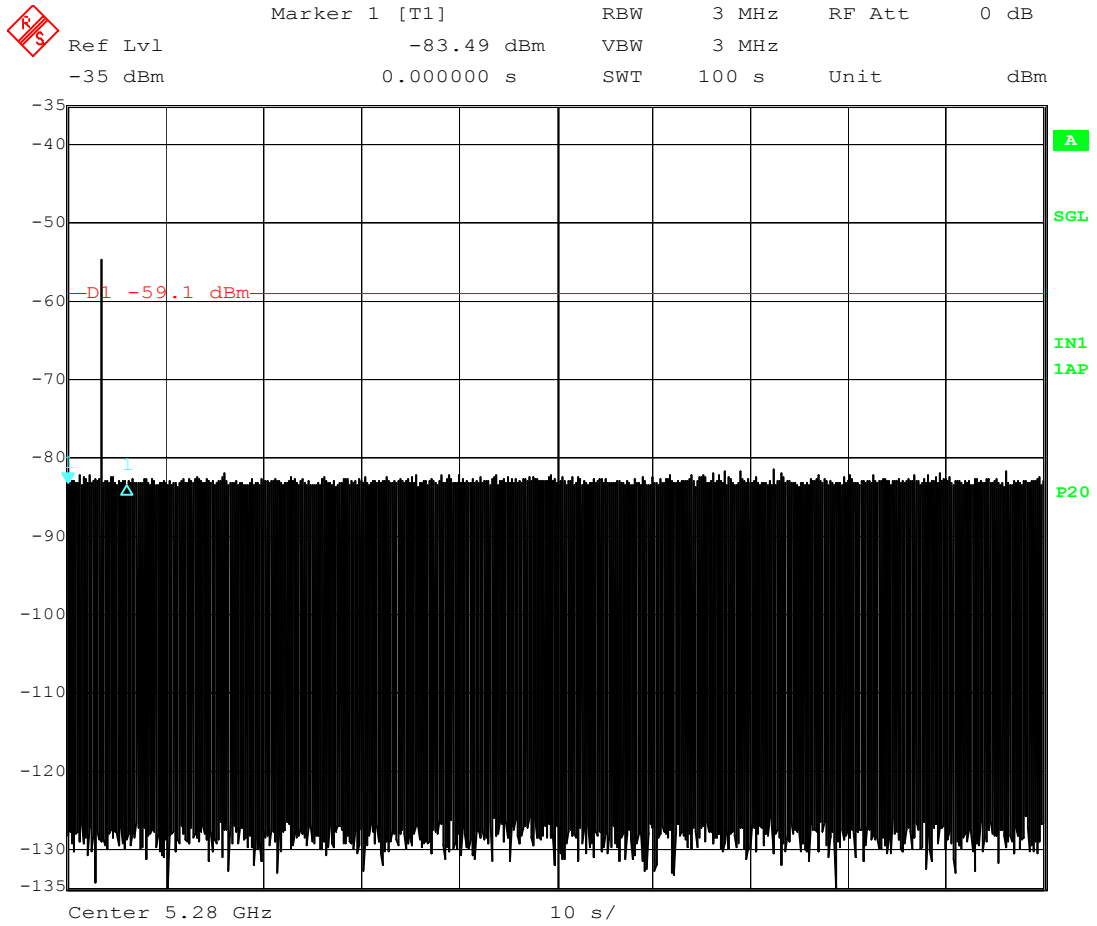

Test Result-5470MHz to 5725MHz band

	Delta 1 [T1]	RBW	3 MHz	RF Att	0 dB
Ref Lvl	0.39 dB	VBW	3 MHz	Unit	dBm
To -35 dBm	6.000000 s	SWT	100 s		

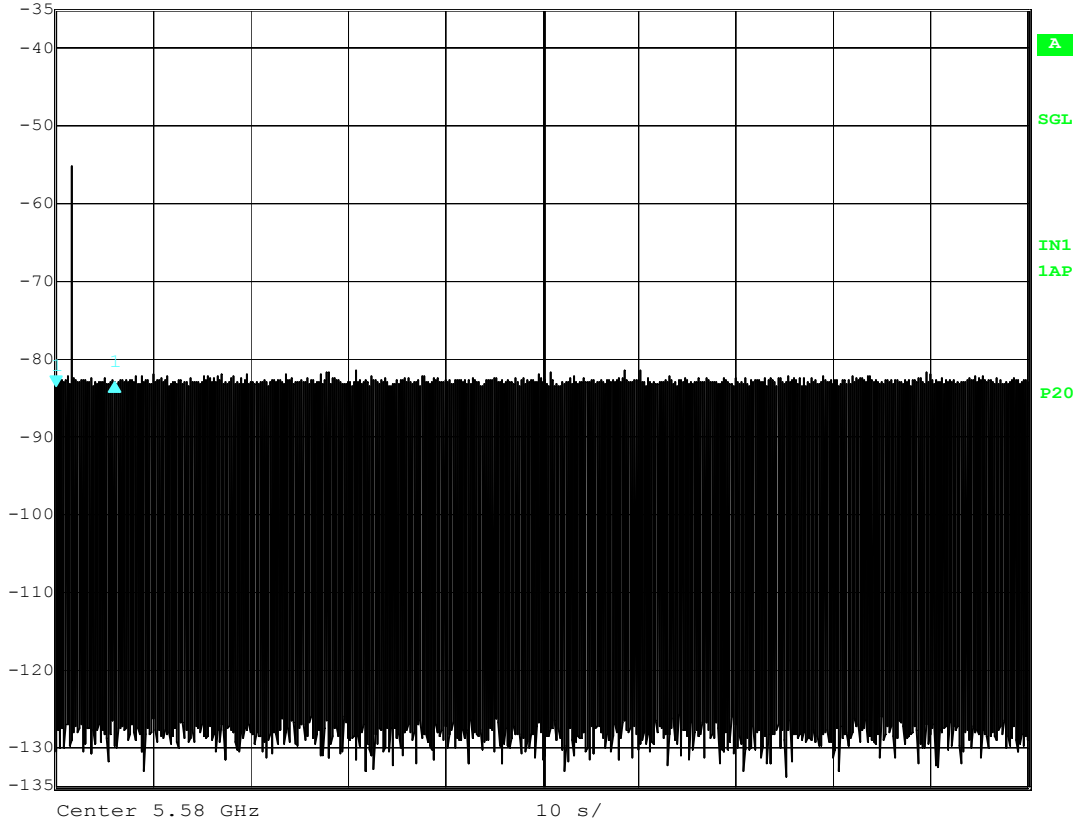

Radar Burst at the End of the Channel Availability Check Time

Radar Burst at the End of the Channel Availability Check Time: The steps below define the procedure to verify successful radar detection on the selected Channel during a period equal to the Channel Availability Check Time and avoidance of operation on that channel when radar burst with a level equal to the DFS Detection Threshold + 1 dB (-59.1dBm) occurs at the end of the Channel Availability Check Time.

The UUT is powered on at T0. T1 denotes the instant when the UUT has completed its power-up sequence. The Channel Availability Check Time commences at instant T1 and will end no sooner than T1 + 60 seconds.

A single Burst of short pulse of radar type 1 at -59.1dBm will commence within a last 6 second window.

Verify that during the 2.5 minute measurement window no UUT transmissions occurred at mid channel. Visual indication on the UUT of successful detection of the radar Burst will be recorded and reported.

Test Result-5250MHz to 5350MHz band

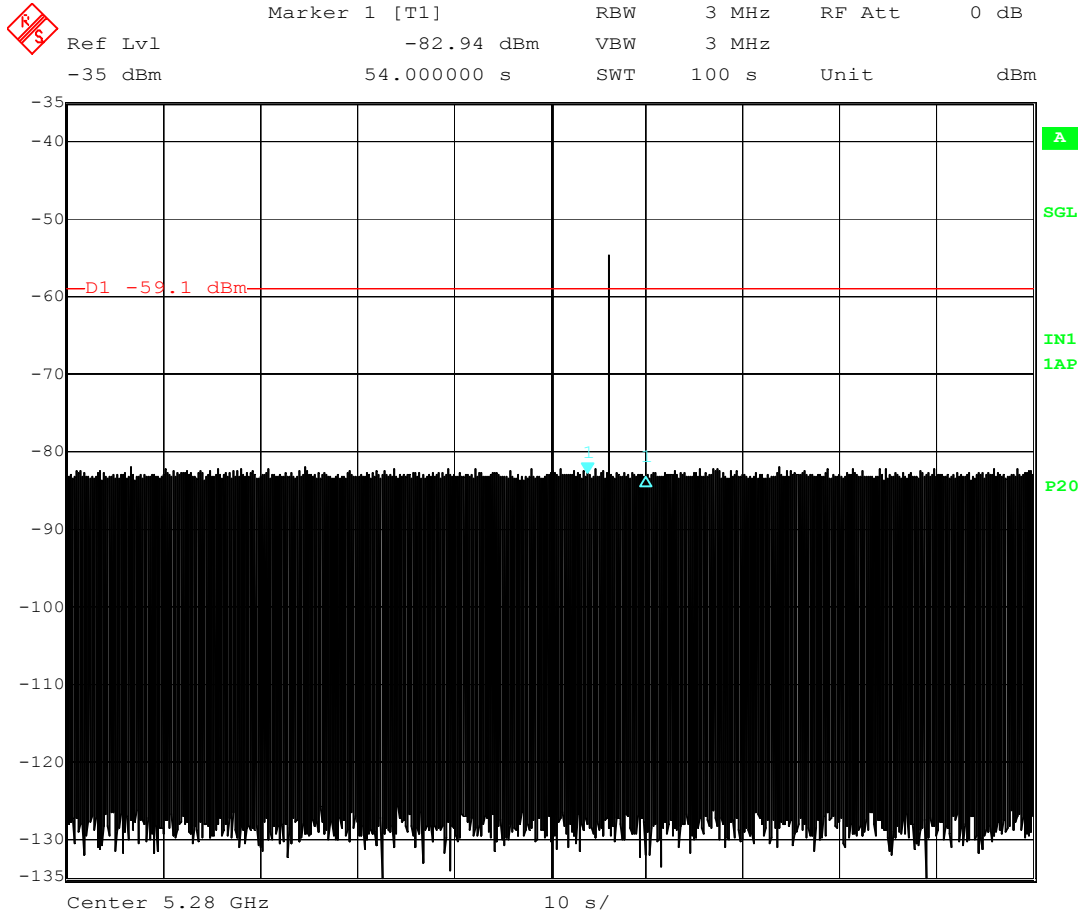

Test Result-5470MHz to 5725MHz band

	Delta 1 [T1]	RBW	3 MHz	RF Att	0 dB
	Ref Lvl	0.21 dB	VBW	3 MHz	
	-35 dBm	6.000000 s	SWT	100 s	Unit

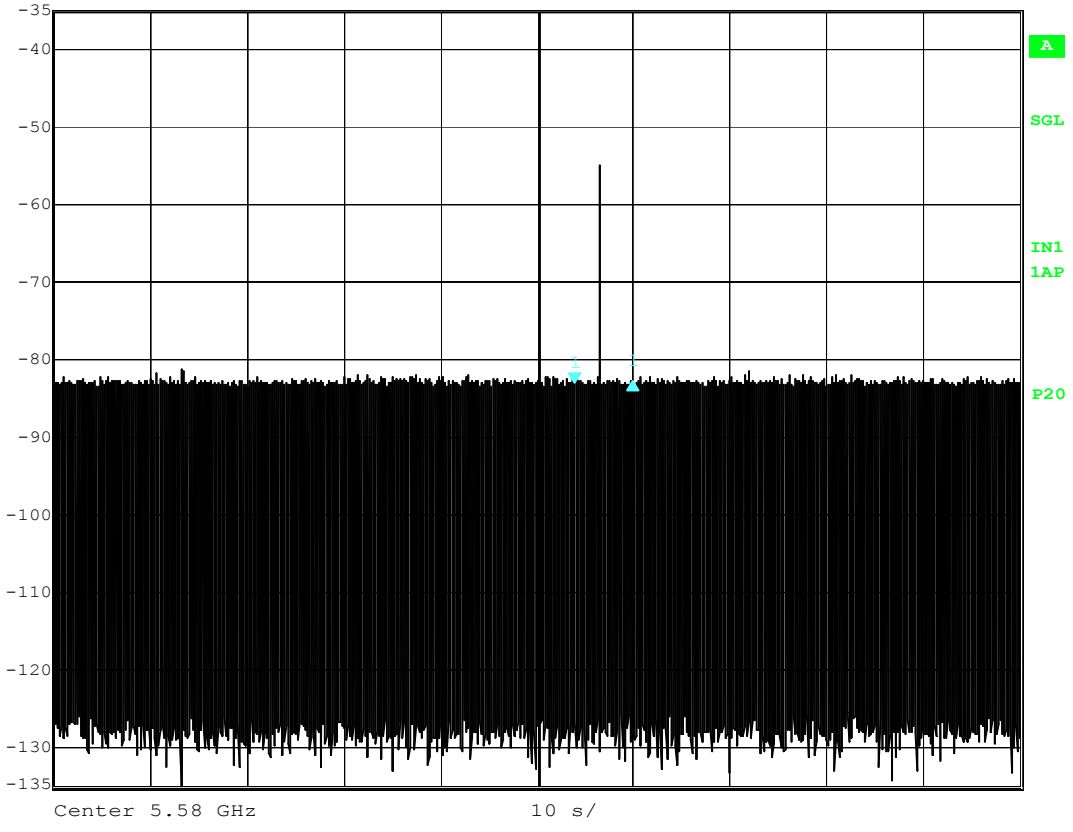

In-Service Monitoring for Channel Move Time, Channel Closing Transmission Time and Non-Occupancy Period

These tests define how the following DFS parameters are verified during In-Service Monitoring; Channel Closing Transmission Time, Channel Move Time, and Non-Occupancy Period.

The steps below define the procedure to determine the above mentioned parameters when a radar Burst with a level equal to the DFS Detection Threshold + 1dB (-59.1dBm) is generated on the Operating Channel of the U-NII device.

A U-NII device operating as a Client Device will associate with the UUT (Master) at Mid Channel. Stream the MPEG test file from the Master Device to the Client Device on the selected Channel for the entire period of the test.

At time T0 the Radar Waveform generator sends a Burst of pulses for each of the radar types at -59.1dBm.

Observe the transmissions of the UUT at the end of the radar Burst on the Operating Channel for duration greater than 10 seconds. Measure and record the transmissions from the UUT during the observation time (Channel Move Time). Compare the Channel Move Time and Channel Closing Transmission Time results to the limits defined in the DFS Response requirement values table.

Channel Closing Transmission Time- Measurement

A type 1 waveform was introduced to the EUT and the Spectrum Analyzer sweep time was set to 1s for monitoring and capturing the plot. A LabView program was created to collect trace data and capturing the plot. The program will calculate the channel closing time base on the spectrum analyzer result. The result will be calculated based on FCC procedure.

$$C = N * Dwell$$

C is the closing time, N is the number of spectrum analyzer sampling bins showing a U-NII transmission and dwell is the dwell time per bin.

$$Dwell = S/B$$

Where Dwell is the dwell time per spectrum analyzer sampling bin, S is the sweep time and B is the number of spectrum analyzer sampling bins.

Radar (Type 1)

Channel Closing Transmission Time for Type 1 Radar

Test Result-5250MHz to 5350MHz band

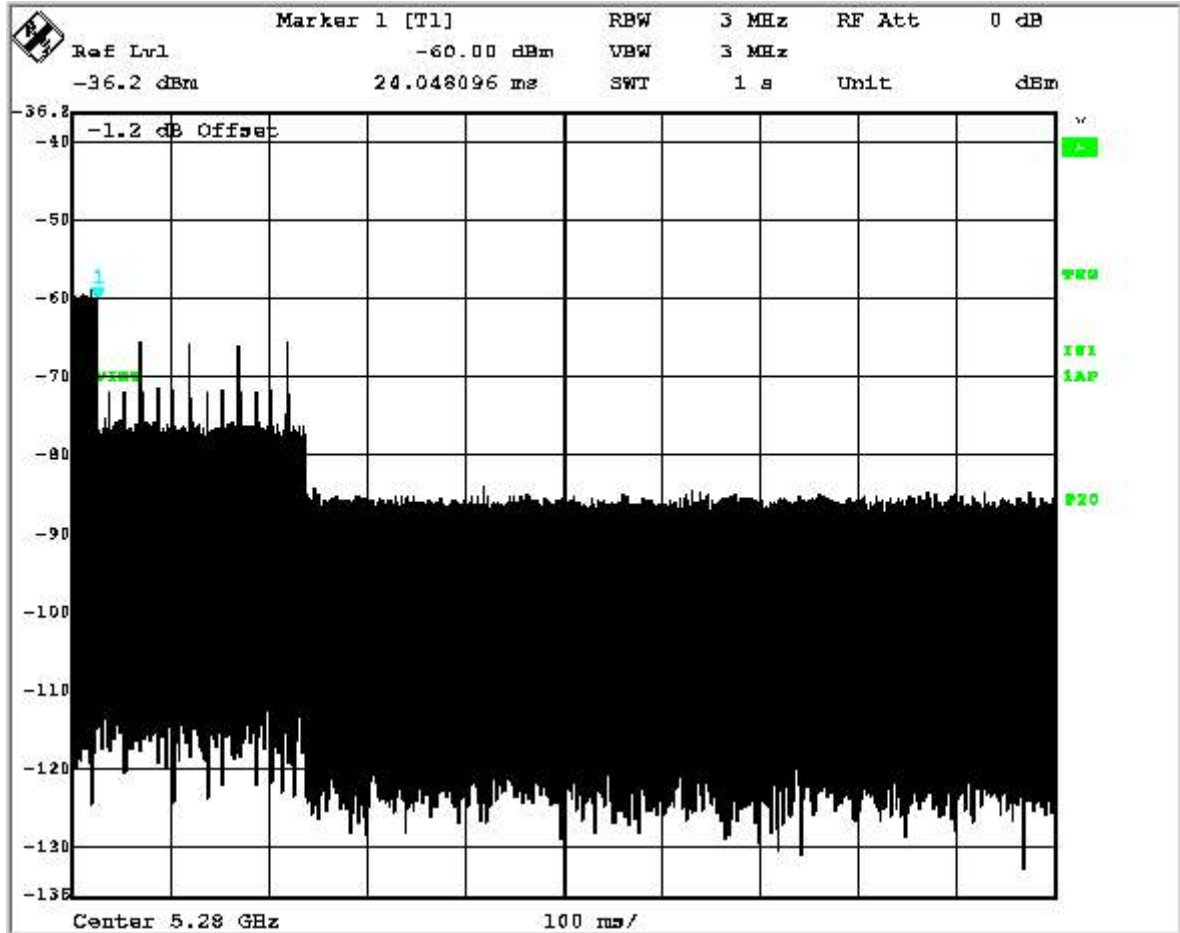

LabiView-Timing Measurement Plot

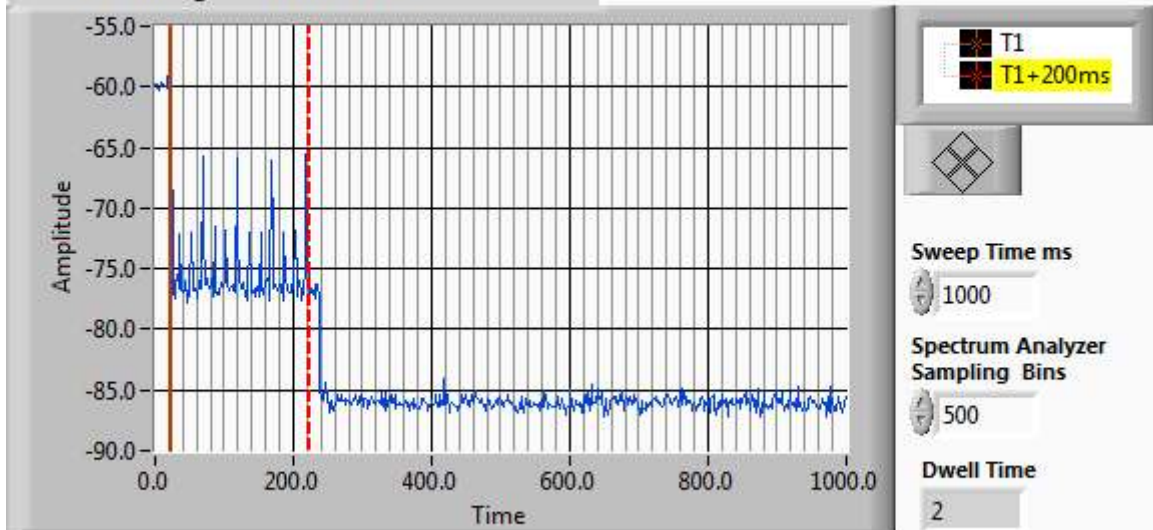

Channel Closing Transmission Time (ms)

12 From T1+200ms

Test Result-5470MHz to 5725MHz band

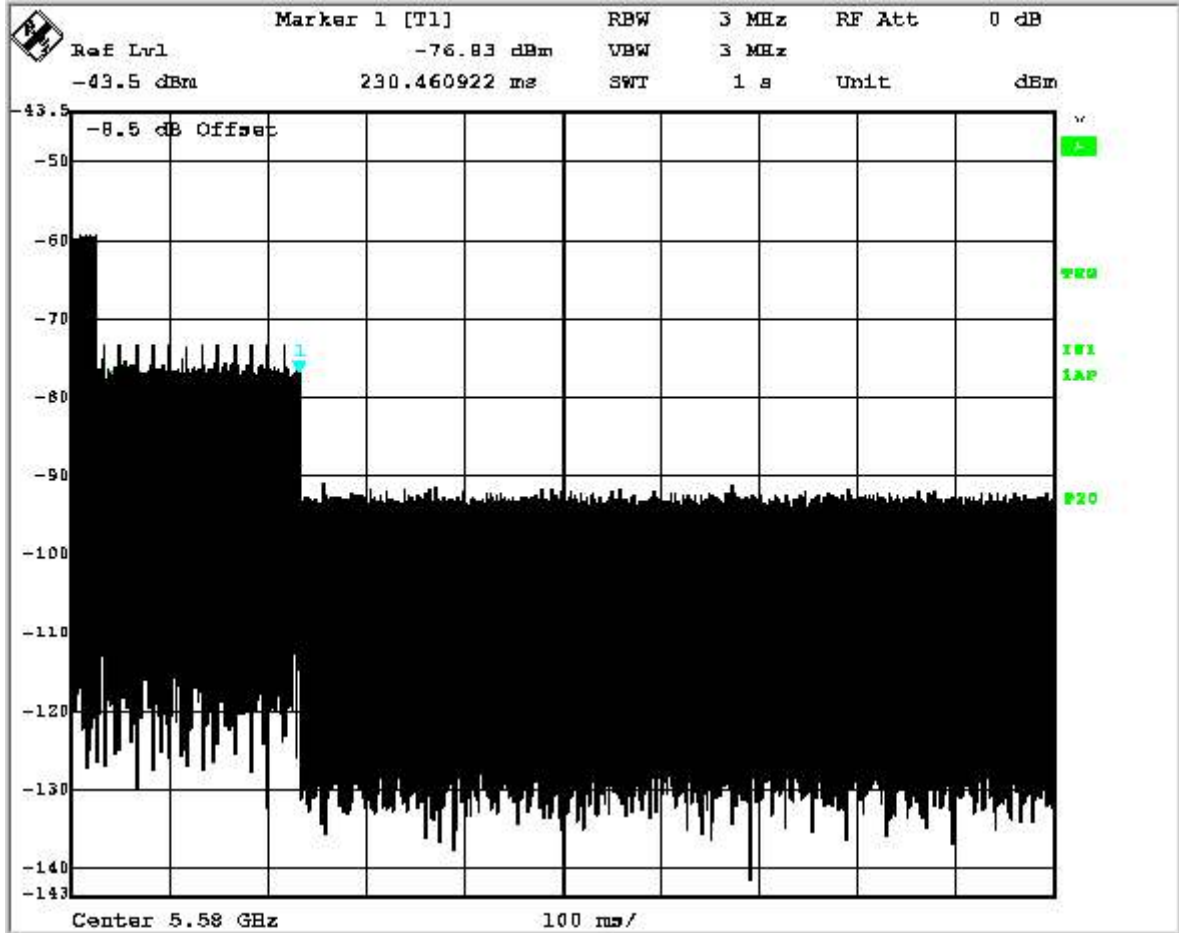

LabiView-Timing Measurement Plot

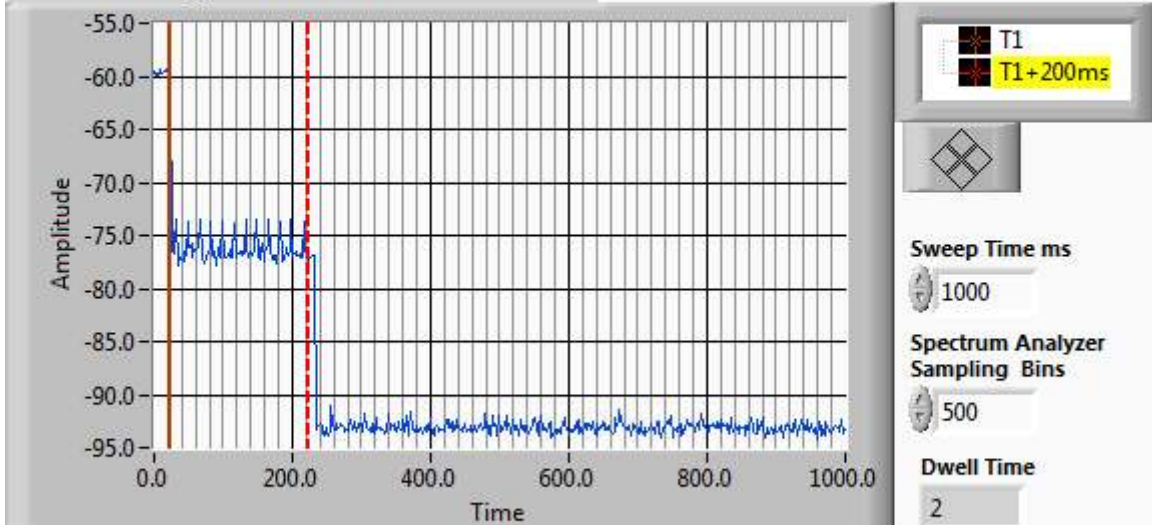

Channel Closing Transmission Time (ms)

8 From T1 + 200ms

Channel Closing Transmission Time and Channel Move Time Radar Type 2
 Test Result-5250MHz to 5350MHz band

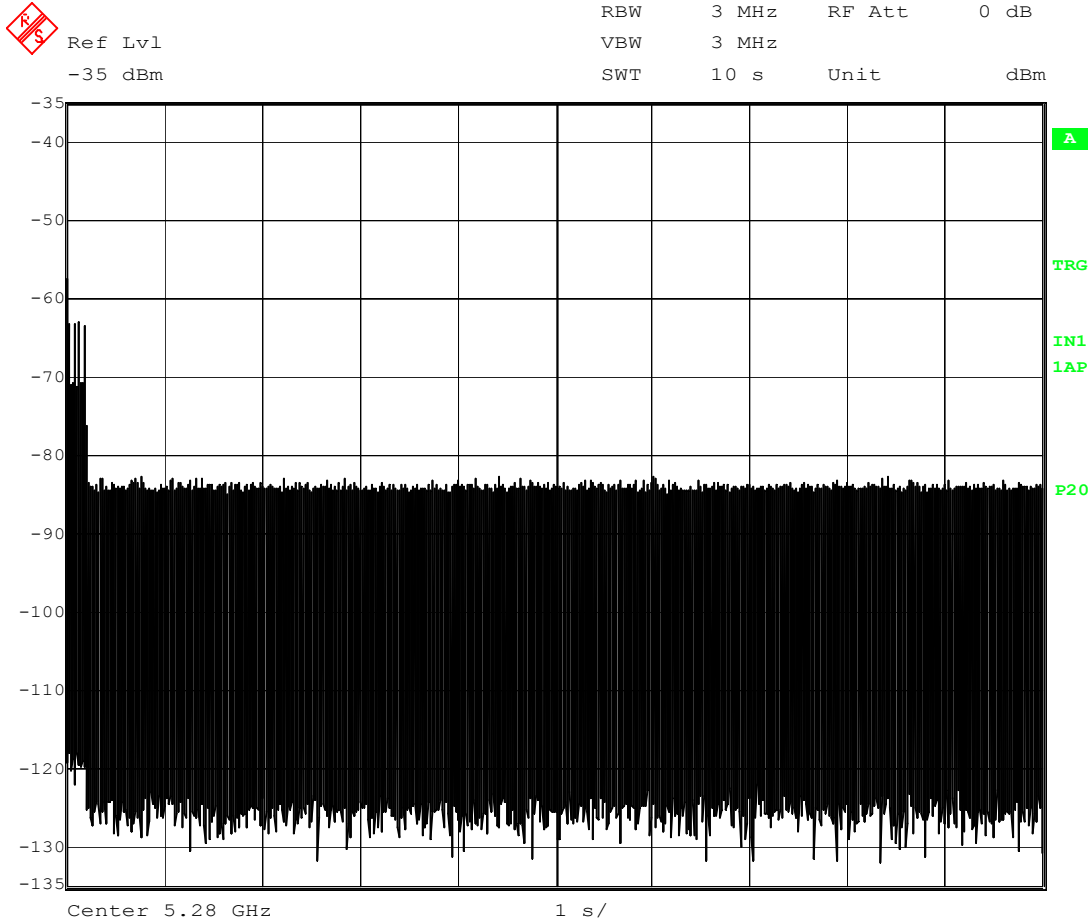

Test Result-5470MHz to 5725MHz band

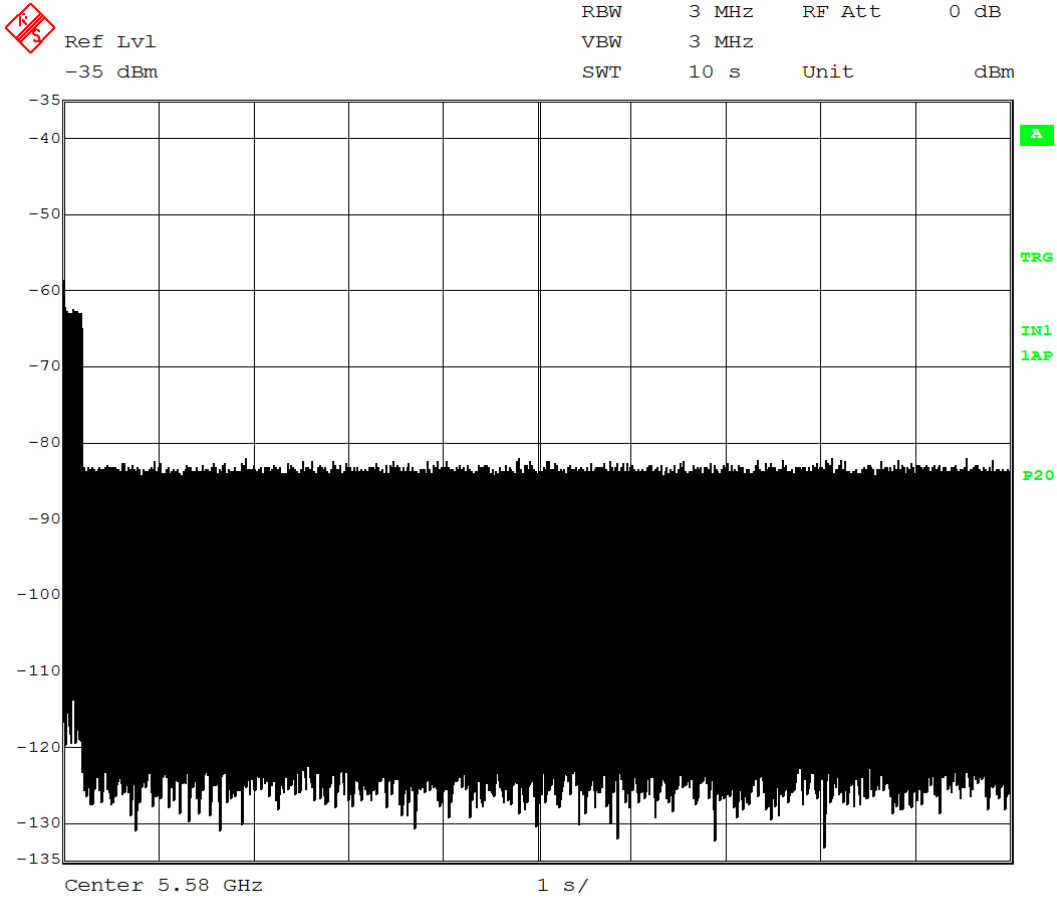

Test Result-5470MHz to 5725MHz band

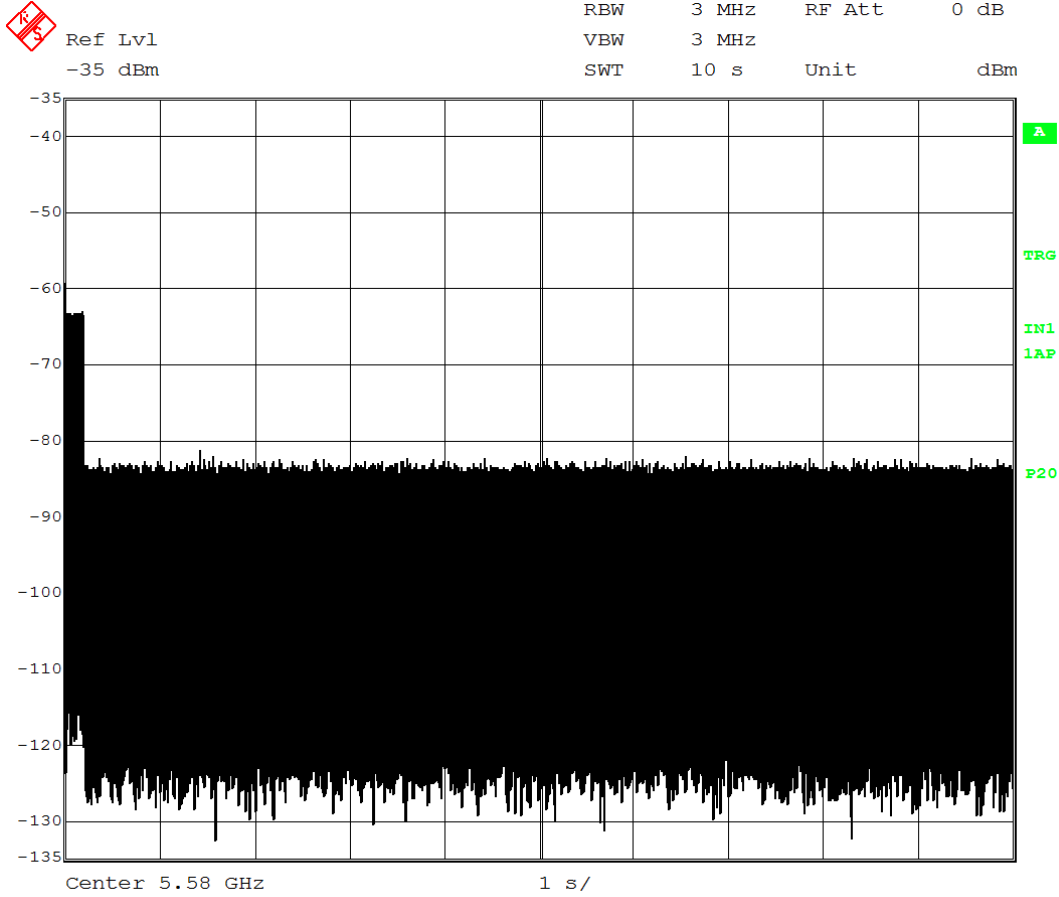

Channel Closing Transmission Time and Channel Move Time Radar Type 4-
 Test Result-5250MHz to 5350MHz band

Mid Channel

	Ref Lvl -35 dBm	RBW 3 MHz	RF Att 0 dB	Unit dBm
		VBW 3 MHz		
		SWT 10 s		

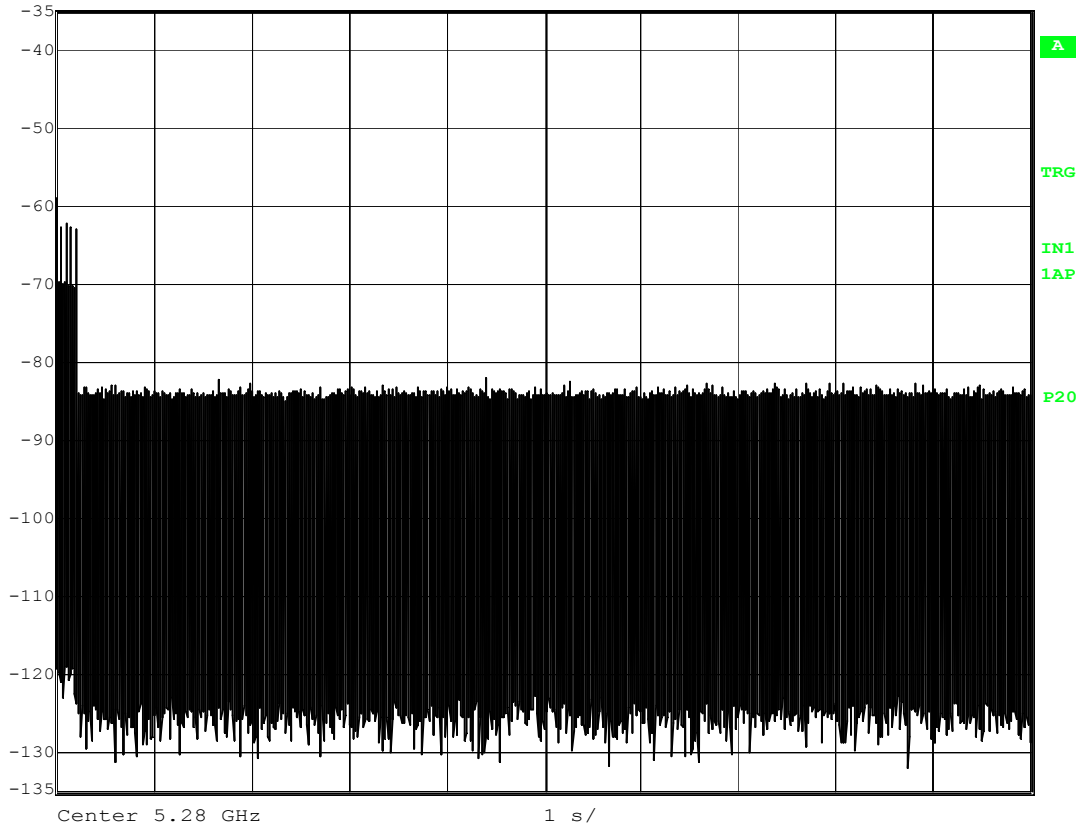

Test Result-5470MHz to 5725MHz band

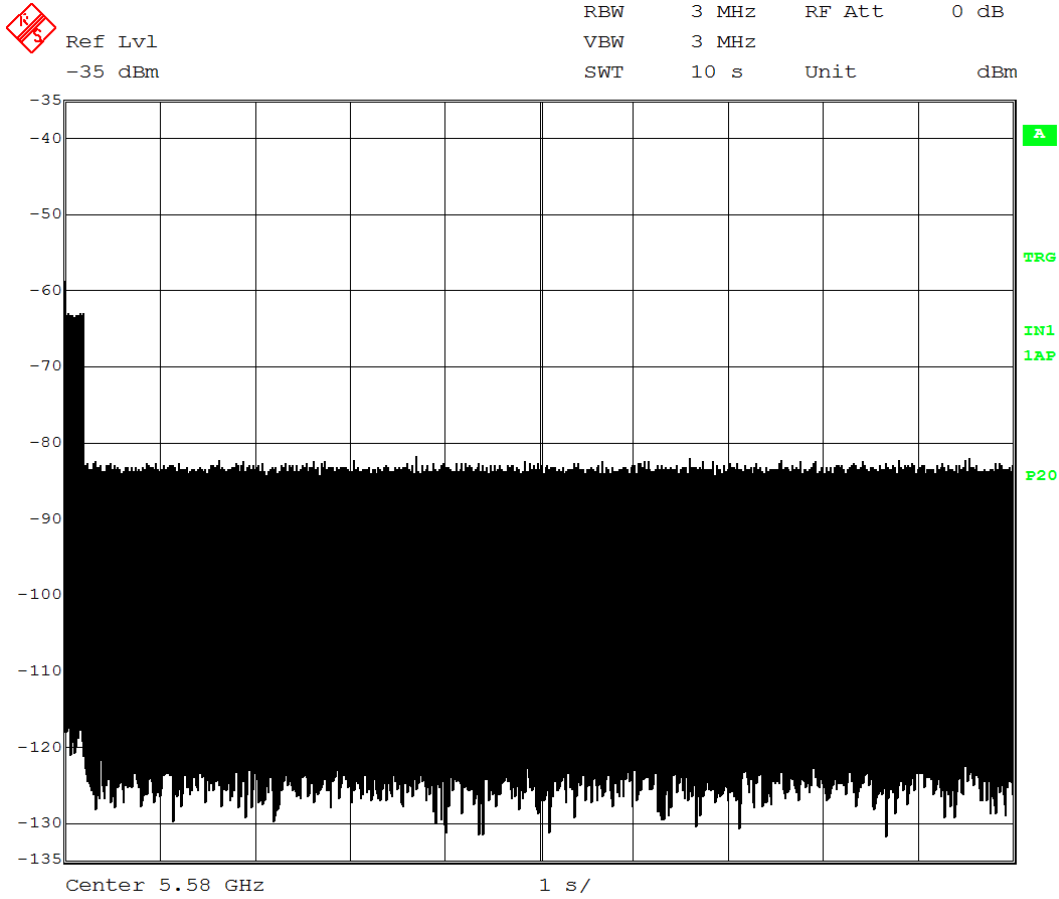

Channel Closing Transmission Time and Channel Move Time Radar Type 5
 Test Result-5250MHz to 5350MHz band

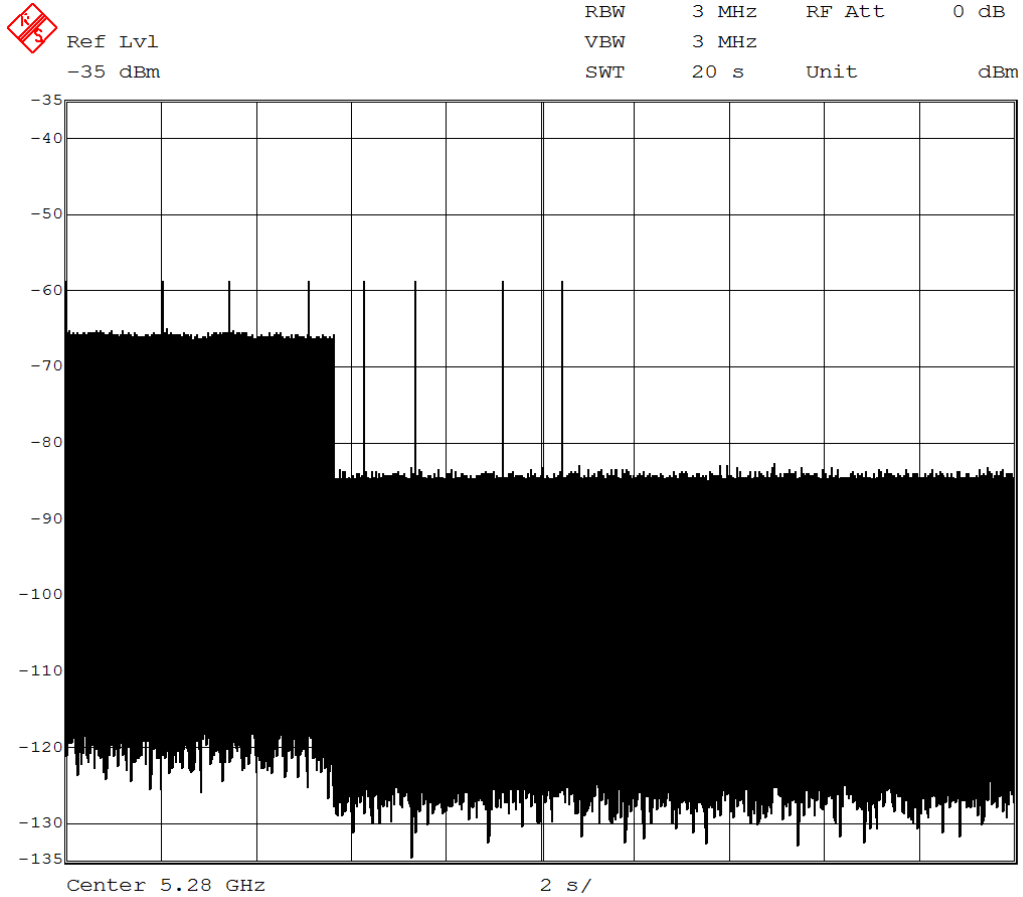

Test Result-5470MHz to 5725MHz band

	Ref Lvl	RBW	3 MHz	RF Att	0 dB
	-35 dBm	VBW	3 MHz		
		SWT	22 s	Unit	dBm

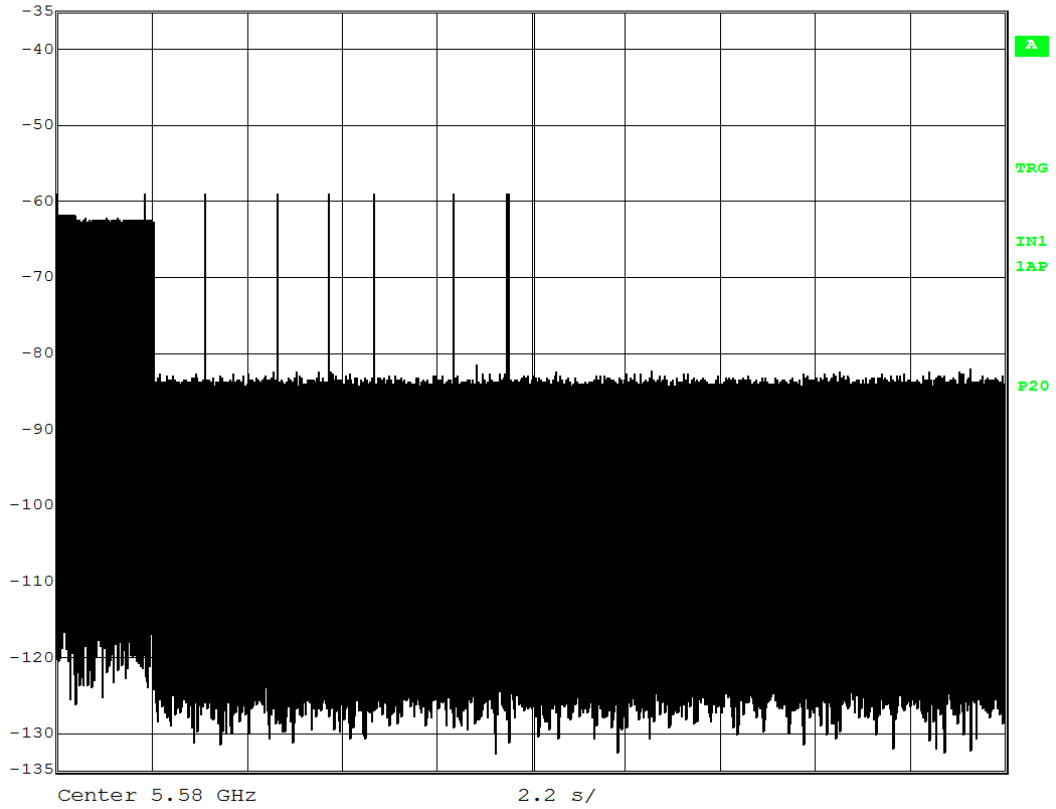

Channel Closing Transmission Time and Channel Move Time Radar Type 6
 Test Result-5250MHz to 5350MHz band

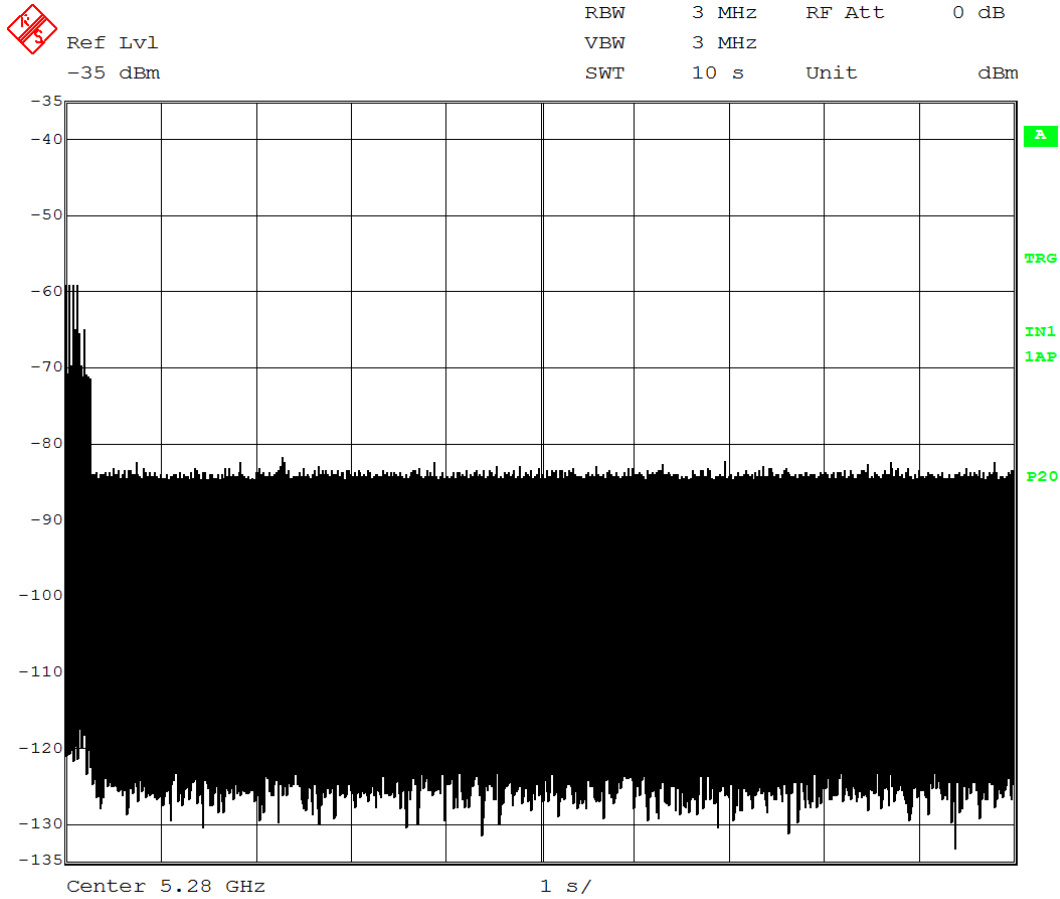

Test Result-5470MHz to 5725MHz band

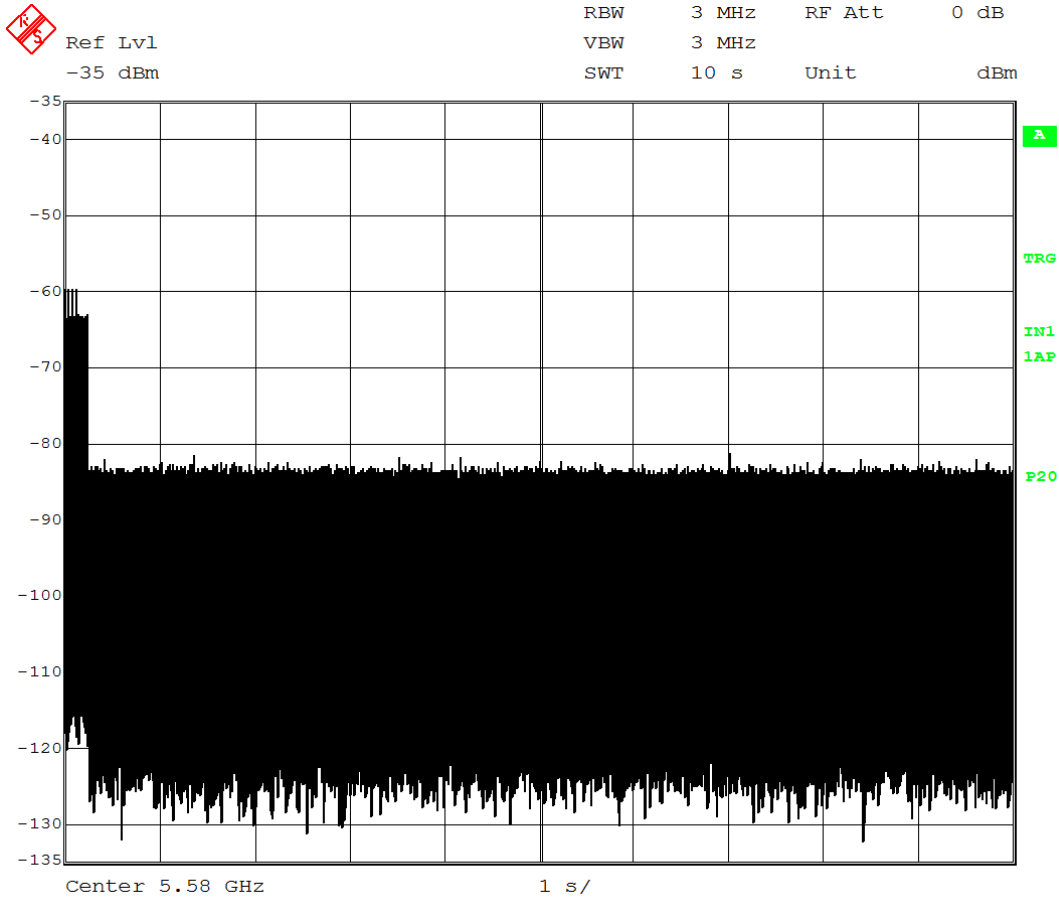

Test Result-5470MHz to 5725MHz band

	Ref Lvl -36.2 dBm	RBW 3 MHz VBW 3 MHz SWT 1850 s	RF Att 0 dB Unit dBm
---	----------------------	--------------------------------------	-------------------------

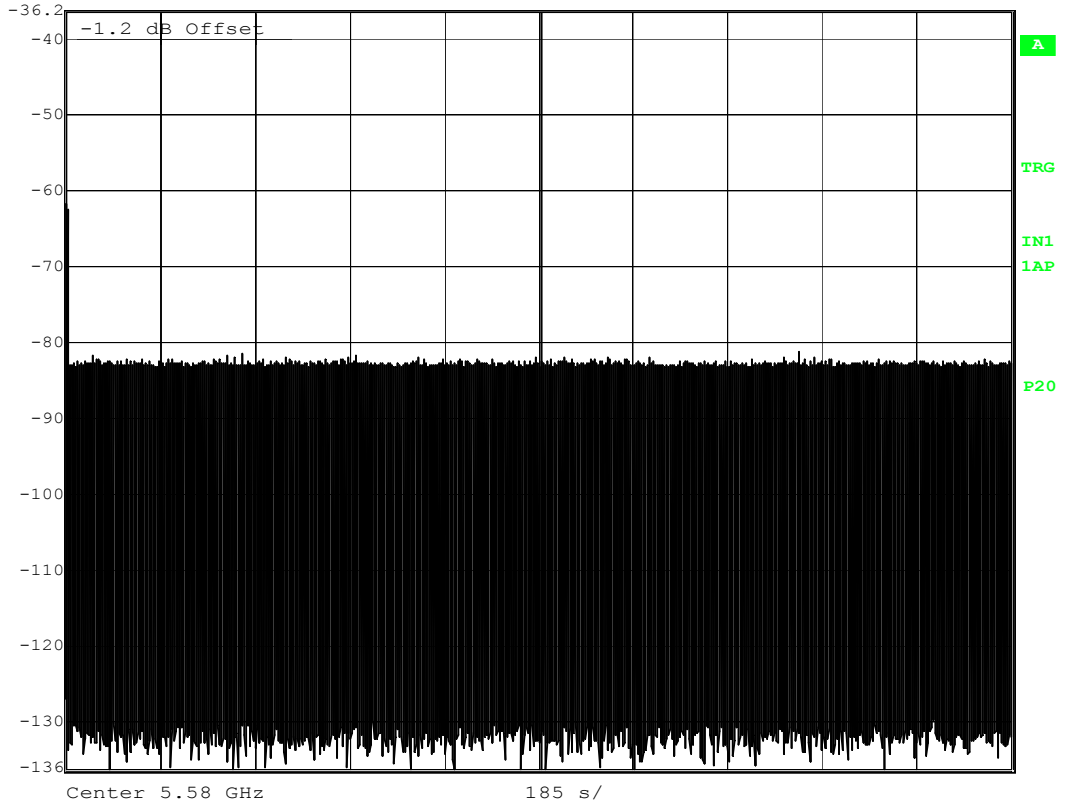

Statistical Performance Check

Statistical Performance Check The steps below define the procedure to determine the minimum percentage of detection when a radar burst with a level equal to the DFS Detection Threshold + 1dB (-59.1dBm) is generated on the Operating Channel of the U-NII device.

A U-NII device operating as a Client Device will associate with the UUT (Master) at Low, Mid and High Channel. Stream the MPEG test file from the Master Device to the Client Device on the selected Channel for the entire period of the test.

The Radar Waveform generator sends the individual waveform for each of the radar types 1-6 at -59.1dBm. Statistical data will be gathered to determine the ability of the device to detect the radar test waveforms. The device can utilize a test mode to demonstrate when detection occurs to prevent the need to reset the device

TotalWaveformDetections

TotalWaveformTrials ×100 = Probability of Detection Radar Waveform calculated by:

The Minimum number of trails, minimum percentage of successful detection and the average minimum percentage of successful detection are found in the Radar Test Waveforms section.

Radar Type 1

Test Result-5250MHz to 5350MHz band

Trial #	Pulse Width (us)	PRI (us)	Pulses/Burst	1=Detection ,Blank=No Detection
1..	1	1	1	1
2..	1	1	1	1
3..	1	1	1	1
4..	1	1	1	1
5..	1	1	1	1
6..	1	1	1	1
7..	1	1	1	1
8..	1	1	1	0
9..	1	1	1	0
10..	1	1	1	0
11..	1	1	1	1
12..	1	1	1	1
13..	1	1	1	1
14..	1	1	1	1
15..	1	1	1	1
16..	1	1	1	1
17..	1	1	1	1
18..	1	1	1	1
19..	1	1	1	1
20..	1	1	1	1
21..	1	1	1	1
22..	1	1	1	1
23..	1	1	1	1
24..	1	1	1	1
25..	1	1	1	1
26..	1	1	1	1
27..	1	1	1	1
28..	1	1	1	1
29..	1	1	1	1
30..	1	1	1	1
Detection Percentage:				90%

Test Result-5470MHz to 5725MHz band

Trial #	Pulse Width (us)	PRI (us)	Pulses/Burst	1=Detection ,Blank=No Detection
1..	1	1428	18	1
2..	1	1428	18	1
3..	1	1428	18	1
4..	1	1428	18	1
5..	1	1428	18	1
6..	1	1428	18	1
7..	1	1428	18	1
8..	1	1428	18	1
9..	1	1428	18	1
10..	1	1428	18	1
11..	1	1428	18	1
12..	1	1428	18	1
13..	1	1428	18	1
14..	1	1428	18	1
15..	1	1428	18	1
16..	1	1428	18	1
17..	1	1428	18	1
18..	1	1428	18	1
19..	1	1428	18	1
20..	1	1428	18	1
21..	1	1428	18	1
22..	1	1428	18	1
23..	1	1428	18	1
24..	1	1428	18	1
25..	1	1428	18	1
26..	1	1428	18	1
27..	1	1428	18	1
28..	1	1428	18	1
29..	1	1428	18	1
30..	1	1428	18	1
Detection Percentage:				80%

Radar Type 2

Test Result-5250MHz to 5350MHz band

Trial #	Pulse Width (us)	PRI (us)	Pulses/Burst	1=Detection, Blank=No Detection
1..	1	150	23	1
2..	2	150	23	1
3..	3	150	23	1
4..	4	150	23	1
5..	5	150	23	1
6..	1	150	24	1
7..	2	150	24	1
8..	3	150	24	1
9..	4	150	24	1
10..	5	150	24	1
11..	1	200	25	1
12..	2	200	25	1
13..	3	200	25	1
14..	4	200	25	0
15..	5	200	25	0
16..	1	200	26	1
17..	2	200	26	1
18..	3	200	26	1
19..	4	200	26	0
20..	5	200	26	1
21..	1	230	27	1
22..	2	230	27	1
23..	3	230	27	1
24..	4	230	27	1
25..	5	230	27	1
26..	1	230	28	1
27..	2	230	28	1
28..	3	230	28	1
29..	4	230	28	1
30..	5	230	28	1
(60%:Pass) Detection Percentage:				90%

Test Result-5470MHz to 5725MHz band

Trial #	Pulse Width (us)	PRI (us)	Pulses/Burst	1=Detection, Blank=No Detection
1..	1	150	23	1
2..	2	150	23	1
3..	3	150	23	0
4..	4	150	23	0
5..	5	150	23	0
6..	1	150	24	1
7..	2	150	24	1
8..	3	150	24	1
9..	4	150	24	1
10..	5	150	24	1
11..	1	200	25	1
12..	2	200	25	1
13..	3	200	25	1
14..	4	200	25	1
15..	5	200	25	1
16..	1	200	26	1
17..	2	200	26	1
18..	3	200	26	1
19..	4	200	26	1
20..	5	200	26	1
21..	1	230	27	1
22..	2	230	27	1
23..	3	230	27	0
24..	4	230	27	1
25..	5	230	27	1
26..	1	230	28	1
27..	2	230	28	1
28..	3	230	28	0
29..	4	230	28	1
30..	5	230	28	1
(60%:Pass) Detection Percentage:				83%

Radar Type 3

Test Result-5250MHz to 5350MHz band

Trial #	Pulse Width (us)	PRI (us)	Pulses/Burst	1=Detection, Blank=No Detection
1..	6	300	17	1
2..	7	300	17	0
3..	8	300	17	1
4..	9	300	17	1
5..	10	300	17	1
6..	6	300	18	1
7..	7	300	18	0
8..	8	300	18	1
9..	9	300	18	1
10..	10	300	18	1
11..	6	400	17	1
12..	7	400	17	1
13..	8	400	17	1
14..	9	400	17	1
15..	10	400	17	1
16..	6	400	18	1
17..	7	400	18	1
18..	8	400	18	1
19..	9	400	18	1
20..	10	400	18	1
21..	6	500	17	1
22..	7	500	17	1
23..	8	500	17	1
24..	9	500	17	1
25..	10	500	17	1
26..	6	500	18	1
27..	7	500	18	1
28..	8	500	18	1
29..	9	500	18	1
30..	10	500	18	1
Detection Percentage:				93%

Test Result-5470MHz to 5725MHz band

Trial #	Pulse Width (us)	PRI (us)	Pulses/Burst	1=Detection, Blank=No Detection
1..	6	300	17	0
2..	7	300	17	1
3..	8	300	17	1
4..	9	300	17	1
5..	10	300	17	1
6..	6	300	18	1
7..	7	300	18	1
8..	8	300	18	1
9..	9	300	18	1
10..	10	300	18	1
11..	6	400	17	1
12..	7	400	17	1
13..	8	400	17	1
14..	9	400	17	1
15..	10	400	17	1
16..	6	400	18	1
17..	7	400	18	1
18..	8	400	18	1
19..	9	400	18	1
20..	10	400	18	1
21..	6	500	17	1
22..	7	500	17	1
23..	8	500	17	1
24..	9	500	17	1
25..	10	500	17	1
26..	6	500	18	1
27..	7	500	18	1
28..	8	500	18	1
29..	9	500	18	1
30..	10	500	18	1
Detection Percentage:				97%

Radar Type 4

Test Result-5250MHz to 5350MHz band

Trial #	Pulse Width (us)	PRI (us)	Pulses/Burst	1=Detection, Blank=No Detection
1..	11	300	12	1
2..	12	300	12	1
3..	13	300	12	1
4..	14	300	12	1
5..	15	300	12	1
6..	16	300	12	1
7..	17	300	12	1
8..	18	300	12	1
9..	19	300	12	0
10..	20	300	12	0
11..	11	400	14	0
12..	12	400	14	1
13..	13	400	14	1
14..	14	400	14	1
15..	15	400	14	1
16..	16	400	14	0
17..	17	400	14	1
18..	18	400	14	1
19..	19	400	14	1
20..	20	400	14	1
21..	11	500	16	0
22..	12	500	16	0
23..	13	500	16	1
24..	14	500	16	1
25..	15	500	16	1
26..	16	500	16	1
27..	17	500	16	1
28..	18	500	16	1
29..	19	500	16	1
30..	20	500	16	1
Detection Percentage:				80%

Test Result-5470MHz to 5725MHz band

Trial #	Pulse Width (us)	PRI (us)	Pulses/Burst	1=Detection, Blank=No Detection
1..	11	300	12	1
2..	12	300	12	1
3..	13	300	12	1
4..	14	300	12	1
5..	15	300	12	0
6..	16	300	12	1
7..	17	300	12	1
8..	18	300	12	0
9..	19	300	12	1
10..	20	300	12	1
11..	11	400	14	1
12..	12	400	14	1
13..	13	400	14	1
14..	14	400	14	1
15..	15	400	14	0
16..	16	400	14	1
17..	17	400	14	1
18..	18	400	14	1
19..	19	400	14	1
20..	20	400	14	1
21..	11	500	16	1
22..	12	500	16	1
23..	13	500	16	1
24..	14	500	16	1
25..	15	500	16	1
26..	16	500	16	1
27..	17	500	16	1
28..	18	500	16	1
29..	19	500	16	0
30..	20	500	16	1
Detection Percentage:				87%

Radar Type 5

Test Result-5250MHz to 5350MHz band

Trial #	Waveform	1=Detection, Blank=No Detection
1..	Waveform 1	1
2..	Waveform 2	1
3..	Waveform 3	1
4..	Waveform 4	1
5..	Waveform 5	1
6..	Waveform 6	1
7..	Waveform 7	1
8..	Waveform 8	1
9..	Waveform 9	1
10..	Waveform 10	1
11..	Waveform 11	1
12..	Waveform 12	1
13..	Waveform 13	1
14..	Waveform 14	1
15..	Waveform 15	1
16..	Waveform 16	1
17..	Waveform 17	1
18..	Waveform 18	1
19..	Waveform 19	1
20..	Waveform 20	1
21..	Waveform 21	1
22..	Waveform 22	1
23..	Waveform 23	1
24..	Waveform 24	1
25..	Waveform 25	1
26..	Waveform 26	1
27..	Waveform 27	1
28..	Waveform 28	1
29..	Waveform 29	1
30..	Waveform 30	1
Detection Percentage:		100%

*Please see the Annex B for Radar Type 5 waveform characteristic

Test Result-5470MHz to 5725MHz band

Trial #	Waveform	1=Detection, Blank=No Detection
1..	Waveform 1	1
2..	Waveform 2	1
3..	Waveform 3	1
4..	Waveform 4	1
5..	Waveform 5	1
6..	Waveform 6	1
7..	Waveform 7	1
8..	Waveform 8	1
9..	Waveform 9	1
10..	Waveform 10	1
11..	Waveform 11	1
12..	Waveform 12	1
13..	Waveform 13	1
14..	Waveform 14	1
15..	Waveform 15	1
16..	Waveform 16	1
17..	Waveform 17	1
18..	Waveform 18	1
19..	Waveform 19	1
20..	Waveform 20	1
21..	Waveform 21	1
22..	Waveform 22	1
23..	Waveform 23	1
24..	Waveform 24	1
25..	Waveform 25	1
26..	Waveform 26	1
27..	Waveform 27	1
28..	Waveform 28	1
29..	Waveform 29	1
30..	Waveform 30	1
Detection Percentage:		100%

*Please see the Annex B for Radar Type 5 waveform characteristic



SIEMIC, Inc.

Accessing global markets

Title: RF Test Report of Stryker Endoscopy
Model : P23366
To: FCC DFS Test Report

Serial# SL12011902-STR-001_SYNK_Receiver (DFS)
Issue Date Jan 7th, 2013
Page 63 of 109
www.sieminc.com

Radar Type 6

Test Result-5250MHz to 5350MHz band

Trial #	Pulse Width (us)	PRI (us)	Pulses/Burst	1=Detection. Blank=No Detection
1..	1	333	9	1
2..	1	333	9	1
3..	1	333	9	0
4..	1	333	9	1
5..	1	333	9	1
6..	1	333	9	1
7..	1	333	9	1
8..	1	333	9	1
9..	1	333	9	0
10..	1	333	9	1
11..	1	333	9	1
12..	1	333	9	1
13..	1	333	9	1
14..	1	333	9	0
15..	1	333	9	1
16..	1	333	9	1
17..	1	333	9	1
18..	1	333	9	0
19..	1	333	9	1
20..	1	333	9	1
21..	1	333	9	1
22..	1	333	9	1
23..	1	333	9	1
24..	1	333	9	0
25..	1	333	9	1
26..	1	333	9	1
27..	1	333	9	0
28..	1	333	9	1
29..	1	333	9	1
30..	1	333	9	1
Detection Percentage:				80%

Test Result-5470MHz to 5725MHz band

Trial #	Pulse Width (us)	PRI (us)	Pulses/Burst	1=Detection. Blank=No Detection
1..	1	333	9	1
2..	1	333	9	0
3..	1	333	9	1
4..	1	333	9	1
5..	1	333	9	0
6..	1	333	9	1
7..	1	333	9	1
8..	1	333	9	0
9..	1	333	9	1
10..	1	333	9	1
11..	1	333	9	1
12..	1	333	9	0
13..	1	333	9	1
14..	1	333	9	1
15..	1	333	9	1
16..	1	333	9	1
17..	1	333	9	1
18..	1	333	9	1
19..	1	333	9	1
20..	1	333	9	1
21..	1	333	9	0
22..	1	333	9	1
23..	1	333	9	1
24..	1	333	9	1
25..	1	333	9	1
26..	1	333	9	1
27..	1	333	9	1
28..	1	333	9	0
29..	1	333	9	1
30..	1	333	9	1
Detection Percentage:				80%

Annex A. TEST INSTRUMENT & METHOD

Annex A.i. TEST INSTRUMENTATION & GENERAL PROCEDURES

Instrument	Model	Serial #	Calibration Due
R&S EMI Test Receiver	ESIB 40	100179	4/20/2013
Dual Channels Arbitrary Waveform Generator (Tabor Electronics Ltd)	WWW-1072	207593	6/04/2013
Synthesized Signal Generator (Agilent/HP)	HP8665B	3744A01304	5/14/2013
Synthesized Sweep Generator (Anritsu/Wultron)	68169B	973407	5/18/2013
Splitter/Combiner (Mini-Circuit)	ZFSC-2-9G+	S F030000719	N/A
Splitter/Combiner (Mini-Circuit)	ZFSC-2-9G+	S F030000718	N/A
Attenuator (30dB)	-	-	N/A
Attenuator (20dB)	-	-	N/A
Attenuator (10dB)	-	-	N/A
Attenuator (6dB)	-	-	N/A
Attenuator (3dB)	-	-	N/A

Annex B Radar Type 5 waveform characteristic

Waveform 1

Burst #	Burst Interval(s)	Number of Pulses	Pulse Width (us)	Pulse Spacing(us)	Pulse Start (s)	Chirp Width (MHZ)
1	0.0 - 1.5	2	60	1728	0.51	20
2	1.5 - 3.0	3	76	1076, 1580	2.55	10
3	3.0 - 4.5	3	72	1872, 1208	3.96	20
4	4.5 - 6.0	2	76	1860	5.655	10
5	6.0 - 7.5	3	100	1400, 1860	6.825	20
6	7.5 - 9.0	1	52	/	7.89	10
7	9.0 - 10.5	3	92	1460, 1720	9.735	20
8	10.5 - 12.0	3	64	1704, 1240	10.98	10

Waveform 2

Burst #	Burst Interval(s)	Number of Pulses	Pulse Width (us)	Pulse Spacing(us)	Pulse Start (s)	Chirp Width (MHZ)
1	0.0 - 1.5	1	96	/	0.315	20
2	1.5 - 3.0	2	56	1784	1.68	10
3	3.0 - 4.5	3	100	1204, 1064	3.675	20
4	4.5 - 6.0	1	72	/	4.905	10
5	6.0 - 7.5	1	92	/	6.75	20
6	7.5 - 9.0	3	68	1060, 1808	7.71	10
7	9.0 - 10.5	3	72	1824, 1700	9.45	20
8	10.5 - 12.0	1	64	/	11.355	10

Waveform 3

Burst #	Burst Interval(s)	Number of Pulses	Pulse Width (us)	Pulse Spacing(us)	Pulse Start (s)	Chirp Width (MHZ)
1	0.0 - 1.5	1	76	/	0.705	20
2	1.5 - 3.0	2	88	1964	2.505	10
3	3.0 - 4.5	1	100	/	3.375	20
4	4.5 - 6.0	1	60	/	5.19	10
5	6.0 - 7.5	1	64	/	6.585	20
6	7.5 - 9.0	1	56	/	7.905	10
7	9.0 - 10.5	1	100	/	9.75	20
8	10.5 - 12.0	3	96	1256, 1104	11.04	10

Waveform 4

Burst #	Burst Interval(s)	Number of Pulses	Pulse Width (us)	Pulse Spacing(us)	Pulse Start (s)	Chirp Width (MHZ)
1	0.0 - 1.5	1	52	/	0.645	20
2	1.5 - 3.0	3	56	1836, 1788	1.845	10
3	3.0 - 4.5	2	52	1416	3.66	20
4	4.5 - 6.0	2	56	1812	5.52	10
5	6.0 - 7.5	1	80	/	6.6	20
6	7.5 - 9.0	3	92	1928, 1036	8.58	10
7	9.0 - 10.5	2	84	2000	9.24	20
8	10.5 - 12.0	2	88	1036	11.115	10

Waveform 5

Burst #	Burst Interval(s)	Number of Pulses	Pulse Width (us)	Pulse Spacing(us)	Pulse Start (s)	Chirp Width (MHZ)
1	0.0 - 1.5	2	56	1952	0.435	20
2	1.5 - 3.0	1	60	/	2.04	10
3	3.0 - 4.5	2	92	1064	3.99	20
4	4.5 - 6.0	2	64	1540	4.875	10
5	6.0 - 7.5	1	72	/	6.525	20
6	7.5 - 9.0	2	76	1692	7.785	10
7	9.0 - 10.5	3	80	1900, 1072	9.465	20
8	10.5 - 12.0	2	76	1136	10.74	10

Waveform 6

Burst #	Burst Interval(s)	Number of Pulses	Pulse Width (us)	Pulse Spacing(us)	Pulse Start (s)	Chirp Width (MHZ)
1	0.0 - 1.2	3	56	1484, 1292	0.252	20
2	1.2 - 2.4	3	68	1028, 1424	1.764	10
3	2.4 - 3.6	1	56	/	3.252	20
4	3.6 - 4.8	2	64	1956	3.9	10
5	4.8 - 6.0	2	100	1004	5.088	20
6	6.0 - 7.2	3	88	1368, 1652	6.672	10
7	7.2 - 8.4	3	52	1208, 1656	7.836	20
8	8.4 - 9.6	1	96	/	8.832	10
9	9.6 - 10.8	2	84	1288	9.972	20
10	10.8 - 12.0	1	100	/	11.16	10

Waveform 7

Burst #	Burst Interval(s)	Number of Pulses	Pulse Width (us)	Pulse Spacing(us)	Pulse Start (s)	Chirp Width (MHZ)
1	0.0 - 1.2	3	80	1656, 1788	0.852	20
2	1.2 - 2.4	1	96	/	1.404	10
3	2.4 - 3.6	1	84	/	3.108	20
4	3.6 - 4.8	3	56	1728, 1768	4.536	10
5	4.8 - 6.0	3	76	1596, 1656	5.496	20
6	6.0 - 7.2	3	64	1232, 1696	6.36	10
7	7.2 - 8.4	2	92	1924	7.848	20
8	8.4 - 9.6	1	96	/	8.544	10
9	9.6 - 10.8	1	60	/	9.78	20
10	10.8 - 12.0	1	76	/	10.992	10

Waveform 8

Burst #	Burst Interval(s)	Number of Pulses	Pulse Width (us)	Pulse Spacing(us)	Pulse Start (s)	Chirp Width (MHZ)
1	0.0 - 1.2	3	96	1940, 1260	0.636	20
2	1.2 - 2.4	1	72	/	1.368	10
3	2.4 - 3.6	3	60	1820, 1556	3.276	20
4	3.6 - 4.8	2	92	1416	3.72	10
5	4.8 - 6.0	3	96	1480, 1604	5.496	20
6	6.0 - 7.2	1	56	/	6.528	10
7	7.2 - 8.4	1	68	/	7.764	20
8	8.4 - 9.6	1	64	/	8.772	10
9	9.6 - 10.8	2	88	1232	10.08	20
10	10.8 - 12.0	2	76	1396	11.124	10

Waveform 9

Burst #	Burst Interval(s)	Number of Pulses	Pulse Width (us)	Pulse Spacing (us)	Pulse Start (s)	Chirp Width (MHZ)
1	0.0 - 1.2	1	76	/	0.588	20
2	1.2 - 2.4	1	56	/	1.86	10
3	2.4 - 3.6	3	92	1860, 1084	3.3	20
4	3.6 - 4.8	1	96	/	4.236	10
5	4.8 - 6.0	3	92	1432, 1860	5.28	20
6	6.0 - 7.2	1	100	/	6.264	10
7	7.2 - 8.4	3	64	1544, 1368	8.064	20
8	8.4 - 9.6	2	72	1248	8.724	10
9	9.6 - 10.8	1	76	/	9.828	20
10	10.8 - 12.0	3	84	1136, 1992	11.568	10

Waveform 10

Burst #	Burst Interval(s)	Number of Pulses	Pulse Width (us)	Pulse Spacing(us)	Pulse Start (s)	Chirp Width (MHZ)
1	0.0 - 1.2	1	68	/	0.576	20
2	1.2 - 2.4	1	84	/	1.44	10
3	2.4 - 3.6	3	64	1620, 1340	2.928	20
4	3.6 - 4.8	2	72	1552	4.2	10
5	4.8 - 6.0	3	64	1608, 1880	5.388	20
6	6.0 - 7.2	2	60	1672	6.192	10
7	7.2 - 8.4	3	52	1080, 1344	8.04	20
8	8.4 - 9.6	3	76	1828, 1868	8.568	10
9	9.6 - 10.8	2	56	1032	10.08	20
10	10.8 - 12.0	3	64	1728, 1256	11.088	10

Waveform 11

Burst #	Burst Interval(s)	Number of Pulses	Pulse Width (us)	Pulse Spacing(us)	Pulse Start (s)	Chirp Width (MHZ)
1	1	3	72	1440, 1968	0.14	20
2	2	1	64	/	1.42	10
3	3	2	60	1924	2.79	20
4	4	3	88	1188, 1956	3.17	10
5	5	3	52	1380, 1472	4.75	20
6	6	1	64	/	5.57	10
7	7	2	68	1856	6.76	20
8	8	1	100	/	7.59	10
9	9	1	72	/	8.7	20
10	10	3	60	1328, 1160	9.24	10
11	11	3	80	1740, 1248	10.72	20
12	12	2	88	1448	11.28	10

Waveform 12

Burst #	Burst Interval(s)	Number of Pulses	Pulse Width (us)	Pulse Spacing(us)	Pulse Start (s)	Chirp Width (MHZ)
1	1	1	100	/	0.61	20
2	2	3	92	1680, 1104	1.2	10
3	3	1	88	/	2.46	20
4	4	3	80	1628, 1052	3.22	10
5	5	2	68	1356	4.5	20
6	6	2	80	1532	5.15	10
7	7	1	52	/	6.33	20
8	8	2	60	1828	7.57	10
9	9	2	72	1492	8.74	20
10	10	2	80	1096	9.21	10
11	11	1	88	/	10.62	20
12	12	3	100	1744, 1860	11.65	10

Waveform13

Burst #	Burst Interval(s)	Number of Pulses	Pulse Width (us)	Pulse Spacing(us)	Pulse Start (s)	Chirp Width (MHZ)
1	1	3	84	1576, 1216	0.72	20
2	2	1	92	/	1.27	10
3	3	3	52	1356, 1236	2.68	20
4	4	3	80	1096, 1252	3.79	10
5	5	2	52	1224	4.7	20
6	6	3	76	1532, 1684	5.47	10
7	7	1	60	/	6.16	20
8	8	1	56	/	7.1	10
9	9	2	100	1572	8.44	20
10	10	1	72	/	9.41	10
11	11	2	80	1004	10.61	20
12	12	1	84	/	11.21	10

Waveform 14

Burst #	Burst Interval(s)	Number of Pulses	Pulse Width (us)	Pulse Spacing(us)	Pulse Start (s)	Chirp Width (MHZ)
1	1	1	80	/	0.48	20
2	2	1	92	/	1.66	10
3	3	1	88	/	2.51	20
4	4	2	96	1372	3.29	10
5	5	1	84	/	4.27	20
6	6	2	64	1396	5.28	10
7	7	2	80	1572	6.79	20
8	8	2	68	1932	7.21	10
9	9	1	60	/	8.11	20
10	10	1	68	/	9.15	10
11	11	1	84	/	10.2	20
12	12	3	100	1328, 1812	11.33	10

Waveform 15

Burst #	Burst Interval(s)	Number of Pulses	Pulse Width (us)	Pulse Spacing(us)	Pulse Start (s)	Chirp Width (MHZ)
1	1	1	80	/	0.71	20
2	2	3	96	1508, 1240	1.38	10
3	3	2	60	1072	2.7	20
4	4	2	64	1812	3.5	10
5	5	2	60	1672	4.57	20
6	6	2	92	1412	5.23	10
7	7	1	56	/	6.29	20
8	8	3	96	1812, 1336	7.3	10
9	9	2	88	1584	8.15	20
10	10	2	72	1700	9.49	10
11	11	1	76	/	10.37	20
12	12	2	68	1060	11.52	10

Waveform 16

Burst #	Burst Interval(s)	Number of Pulses	Pulse Width (us)	Pulse Spacing(us)	Pulse Start (s)	Chirp Width (MHZ)
1	0.00 - 0.80	3	92	1244, 1572	0.496	20
2	0.80 - 1.60	1	80	/	1.232	10
3	1.60 - 2.40	3	84	1432, 1632	1.688	20
4	2.40 - 3.20	3	60	1448, 1972	2.816	10
5	3.20 - 4.00	3	92	1080, 1184	3.32	20
6	4.00 - 4.80	3	96	1160, 1228	4.28	10
7	4.80 - 5.60	3	60	1036, 1736	4.936	20
8	5.60 - 6.40	2	56	1172	6.008	10
9	6.40 - 7.20	1	52	/	6.6	20
10	7.20 - 8.00	2	76	1980	7.512	10
11	8.00 - 8.80	3	80	1280, 1588	8.224	20
12	8.80 - 9.60	2	68	1664	9.008	10
13	9.60 - 10.40	2	92	1676	10.168	20
14	10.40 - 11.20	2	84	1332	10.728	10
15	11.20 - 12.00	2	60	1684	11.496	20

Waveform 17

Burst #	Burst Interval(s)	Number of Pulses	Pulse Width (us)	Pulse Spacing(us)	Pulse Start (s)	Chirp Width (MHZ)
1	0.00 - 0.80	1	72	/	0.632	20
2	0.80 - 1.60	3	92	1884, 1104	1.424	10
3	1.60 - 2.40	1	84	/	2.08	20
4	2.40 - 3.20	2	60	1912	2.912	10
5	3.20 - 4.00	3	72	1584, 1492	3.608	20
6	4.00 - 4.80	3	60	1588, 1752	4.272	10
7	4.80 - 5.60	2	64	1780	5.168	20
8	5.60 - 6.40	3	76	1588, 1744	5.808	10
9	6.40 - 7.20	1	56	/	6.888	20
10	7.20 - 8.00	2	76	1940	7.512	10
11	8.00 - 8.80	2	92	1444	8.592	20
12	8.80 - 9.60	3	60	1988, 1864	9.4	10
13	9.60 - 10.40	1	100	/	9.864	20
14	10.40 - 11.20	3	84	1284, 1748	10.728	10
15	11.20 - 12.00	2	100	1900	11.752	20

Waveform 18

Burst #	Burst Interval(s)	Number of Pulses	Pulse Width (us)	Pulse Spacing(us)	Pulse Start (s)	Chirp Width (MHZ)
1	0.00 - 0.80	1	56	/	0.504	20
2	0.80 - 1.60	3	76	1116, 1584	1.208	10
3	1.60 - 2.40	1	80	/	1.72	20
4	2.40 - 3.20	1	100	/	2.664	10
5	3.20 - 4.00	3	84	1264, 1140	3.568	20
6	4.00 - 4.80	1	72	/	4.544	10
7	4.80 - 5.60	3	56	1872, 1108	4.944	20
8	5.60 - 6.40	3	60	1320, 1920	6.208	10
9	6.40 - 7.20	2	76	1756	6.744	20
10	7.20 - 8.00	3	60	1596, 1400	7.776	10
11	8.00 - 8.80	1	56	/	8.36	20
12	8.80 - 9.60	3	88	1356, 1840	9.336	10
13	9.60 - 10.40	2	64	1712	9.896	20
14	10.40 - 11.20	1	100	/	10.984	10
15	11.20 - 12.00	3	76	1028, 1688	11.76	20

Waveform 19

Burst #	Burst Interval(s)	Number of Pulses	Pulse Width (us)	Pulse Spacing(us)	Pulse Start (s)	Chirp Width (MHZ)
1	0.00 - 0.80	1	84	/	0.408	20
2	0.80 - 1.60	3	64	1780, 1296	1.304	10
3	1.60 - 2.40	3	68	1400, 1292	1.824	20
4	2.40 - 3.20	1	92	/	2.944	10
5	3.20 - 4.00	1	64	/	3.352	20
6	4.00 - 4.80	2	56	1264	4.232	10
7	4.80 - 5.60	1	72	/	4.92	20
8	5.60 - 6.40	2	76	1460	5.992	10
9	6.40 - 7.20	1	84	/	6.528	20
10	7.20 - 8.00	2	68	1188	7.44	10
11	8.00 - 8.80	3	72	1576, 1536	8.456	20
12	8.80 - 9.60	2	64	1056	8.968	10
13	9.60 - 10.40	1	100	/	9.808	20
14	10.40 - 11.20	2	52	1092	10.616	10
15	11.20 - 12.00	3	68	1936, 1464	11.528	20

Waveform 20

Burst #	Burst Interval(s)	Number of Pulses	Pulse Width (us)	Pulse Spacing(us)	Pulse Start (s)	Chirp Width (MHZ)
1	0.00 - 0.80	1	88	/	0.2	20
2	0.80 - 1.60	1	68	/	1.376	10
3	1.60 - 2.40	2	88	1496	1.92	20
4	2.40 - 3.20	1	64	/	2.608	10
5	3.20 - 4.00	3	84	1768, 1184	3.584	20
6	4.00 - 4.80	3	52	1620, 1552	4.568	10
7	4.80 - 5.60	3	80	1908, 1884	5.432	20
8	5.60 - 6.40	3	92	1728, 1684	6.032	10
9	6.40 - 7.20	3	60	1536, 1496	6.928	20
10	7.20 - 8.00	3	76	1776, 1580	7.304	10
11	8.00 - 8.80	1	80	/	8.36	20
12	8.80 - 9.60	3	56	1020, 1292	9.072	10
13	9.60 - 10.40	2	60	1380	9.712	20
14	10.40 - 11.20	3	96	1324, 1664	10.992	10
15	11.20 - 12.00	2	72	1896	11.416	20

Waveform 21

Burst #	Burst Interval(s)	Number of Pulses	Pulse Width (us)	Pulse Spacing(us)	Pulse Start (s)	Chirp Width (MHZ)
1	0.00 - 0.75	3	52	1384, 1180	0.3225	20
2	0.75 - 1.50	2	60	1096	1.2525	10
3	1.50 - 2.25	3	72	1520, 1716	1.755	20
4	2.25 - 3.00	1	60	/	2.4675	10
5	3.00 - 3.75	2	56	1292	3.5475	20
6	3.75 - 4.50	2	64	1704	4.23	10
7	4.50 - 5.25	2	84	1708	4.9575	20
8	5.25 - 6.00	3	56	1008, 1624	5.565	10
9	6.00 - 6.75	3	80	1468, 1056	6.5325	20
10	6.75 - 7.50	2	88	1160	7.1325	10
11	7.50 - 8.25	3	56	1216, 1852	7.6575	20
12	8.25 - 9.00	1	52	/	8.37	10
13	9.00 - 9.75	1	80	/	9.45	20
14	9.75 - 10.50	3	60	1020, 1996	9.99	10
15	10.50 - 11.25	3	88	1960, 1620	10.6125	20
16	11.25 - 12.00	3	92	1760, 1496	11.46	10

Waveform 22

Burst #	Burst Interval(s)	Number of Pulses	Pulse Width (us)	Pulse Spacing(us)	Pulse Start (s)	Chirp Width (MHZ)
1	0.00 - 0.75	3	56	1704, 1692	0.3825	20
2	0.75 - 1.50	1	100	/	1.335	10
3	1.50 - 2.25	2	92	1068	2.025	20
4	2.25 - 3.00	2	84	1844	2.715	10
5	3.00 - 3.75	2	68	1896	3.0975	20
6	3.75 - 4.50	2	100	1656	3.8775	10
7	4.50 - 5.25	2	60	1960	5.0175	20
8	5.25 - 6.00	1	88	/	5.73	10
9	6.00 - 6.75	1	84	/	6.3975	20
10	6.75 - 7.50	3	56	1784, 1692	7.0125	10
11	7.50 - 8.25	3	52	1784, 1648	7.83	20
12	8.25 - 9.00	1	60	/	8.655	10
13	9.00 - 9.75	3	80	1460, 1564	9.195	20
14	9.75 - 10.50	2	68	1604	10.0875	10
15	10.50 - 11.25	1	76	/	10.77	20
16	11.25 - 12.00	2	96	1276	11.415	10

Waveform 23

Burst #	Burst Interval(s)	Number of Pulses	Pulse Width (us)	Pulse Spacing(us)	Pulse Start (s)	Chirp Width (MHZ)
1	0.00 - 0.75	3	52	1240, 1024	0.2025	20
2	0.75 - 1.50	2	100	1632	0.825	10
3	1.50 - 2.25	3	76	1112, 1156	1.6725	20
4	2.25 - 3.00	2	56	1808	2.43	10
5	3.00 - 3.75	1	64	/	3.585	20
6	3.75 - 4.50	3	68	1960, 1672	4.3425	10
7	4.50 - 5.25	2	52	1700	4.7625	20
8	5.25 - 6.00	1	100	/	5.385	10
9	6.00 - 6.75	3	60	1084, 1112	6.42	20
10	6.75 - 7.50	3	64	1972, 1164	7.0875	10
11	7.50 - 8.25	3	92	1752, 1168	7.845	20
12	8.25 - 9.00	3	80	1448, 1432	8.775	10
13	9.00 - 9.75	2	88	1744	9.39	20
14	9.75 - 10.50	2	92	1548	10.125	10
15	10.50 - 11.25	2	80	1812	11.0625	20
16	11.25 - 12.00	2	52	1508	11.3475	10

Waveform 24

Burst #	Burst Interval(s)	Number of Pulses	Pulse Width (us)	Pulse Spacing(us)	Pulse Start (s)	Chirp Width (MHZ)
1	0.00 - 0.75	2	56	1404	0.2775	20
2	0.75 - 1.50	3	64	1964, 1024	1.1625	10
3	1.50 - 2.25	3	84	1708, 1640	2.0475	20
4	2.25 - 3.00	2	88	1128	2.79	10
5	3.00 - 3.75	1	100	/	3.0825	20
6	3.75 - 4.50	1	60	/	3.885	10
7	4.50 - 5.25	2	96	1436	5.07	20
8	5.25 - 6.00	1	68	/	5.64	10
9	6.00 - 6.75	3	72	1496, 1800	6.3375	20
10	6.75 - 7.50	1	100	/	6.975	10
11	7.50 - 8.25	2	68	1752	8.0025	20
12	8.25 - 9.00	1	84	/	8.6025	10
13	9.00 - 9.75	1	72	/	9.3225	20
14	9.75 - 10.50	2	88	1552	10.215	10
15	10.50 - 11.25	3	52	1884, 1864	10.9425	20
16	11.25 - 12.00	3	60	1776, 1700	11.34	10

Waveform 25

Burst #	Burst Interval(s)	Number of Pulses	Pulse Width (us)	Pulse Spacing(us)	Pulse Start (s)	Chirp Width (MHZ)
1	0.00 - 0.75	1	88	/	0.105	20
2	0.75 - 1.50	1	96	/	1.0125	10
3	1.50 - 2.25	1	60	/	2.055	20
4	2.25 - 3.00	1	80	/	2.5875	10
5	3.00 - 3.75	3	76	1344, 1716	3.2475	20
6	3.75 - 4.50	2	64	1560	4.3275	10
7	4.50 - 5.25	2	84	1964	4.935	20
8	5.25 - 6.00	3	60	1760, 1532	5.7225	10
9	6.00 - 6.75	2	80	1432	6.375	20
10	6.75 - 7.50	1	96	/	7.1925	10
11	7.50 - 8.25	3	60	1904, 1676	7.6125	20
12	8.25 - 9.00	1	80	/	8.535	10
13	9.00 - 9.75	2	68	1724	9.465	20
14	9.75 - 10.50	3	76	1936, 1648	10.2	10
15	10.50 - 11.25	2	88	1728	10.92	20
16	11.25 - 12.00	3	84	1908, 1144	11.64	10

Waveform 26

Burst #	Burst Interval(s)	Number of Pulses	Pulse Width (us)	Pulse Spacing(us)	Pulse Start (s)	Chirp Width (MHZ)
1	0.00 - 0.60	1	96	/	0.36	20
2	0.60 - 1.20	3	80	1072, 1772	0.84	10
3	1.20 - 1.80	1	88	/	1.392	20
4	1.80 - 2.40	1	100	/	2.202	10
5	2.40 - 3.00	2	56	1692	2.718	20
6	3.00 - 3.60	3	84	1572, 1816	3.084	10
7	3.60 - 4.20	1	60	/	3.678	20
8	4.20 - 4.80	1	92	/	4.674	10
9	4.80 - 5.40	3	52	1628, 1704	5.13	20
10	5.40 - 6.00	3	84	1200, 1716	5.466	10
11	6.00 - 6.60	2	80	1580	6.432	20
12	6.60 - 7.20	3	68	1552, 1236	6.66	10
13	7.20 - 7.80	1	60	/	7.482	20
14	7.80 - 8.40	3	88	1192, 1516	8.094	10
15	8.40 - 9.00	3	56	1372, 1284	8.598	20
16	9.00 - 9.60	3	88	1824, 1280	9.354	10
17	9.60 - 10.20	1	60	/	10.014	20
18	10.20 - 10.80	3	84	1644, 1420	10.272	10
19	10.80 - 11.40	3	72	1348, 1724	11.226	20
20	11.40 - 12.00	1	88	/	11.742	10

Waveform 27

Burst #	Burst Interval(s)	Number of Pulses	Pulse Width (us)	Pulse Spacing(us)	Pulse Start (s)	Chirp Width (MHZ)
1	0.00 - 0.60	2	56	1976	0.192	20
2	0.60 - 1.20	2	100	1968	0.78	10
3	1.20 - 1.80	3	60	1892, 1628	1.476	20
4	1.80 - 2.40	3	64	1752, 1328	2.268	10
5	2.40 - 3.00	2	92	1664	2.484	20
6	3.00 - 3.60	2	84	1236	3.234	10
7	3.60 - 4.20	1	64	/	3.858	20
8	4.20 - 4.80	2	80	1280	4.572	10
9	4.80 - 5.40	3	76	1588, 1452	4.92	20
10	5.40 - 6.00	1	64	/	5.688	10
11	6.00 - 6.60	3	80	1464, 1924	6.204	20
12	6.60 - 7.20	1	76	/	6.996	10
13	7.20 - 7.80	1	72	/	7.65	20
14	7.80 - 8.40	1	60	/	8.01	10
15	8.40 - 9.00	2	76	1320	8.694	20
16	9.00 - 9.60	2	100	1684	9.408	10
17	9.60 - 10.20	2	56	1656	9.822	20
18	10.20 - 10.80	3	80	1064, 1868	10.374	10
19	10.80 - 11.40	1	60	/	10.866	20
20	11.40 - 12.00	3	88	1124, 1952	11.718	10

Waveform 28

Burst #	Burst Interval(s)	Number of Pulses	Pulse Width (us)	Pulse Spacing(us)	Pulse Start (s)	Chirp Width (MHZ)
1	0.00 - 0.60	2	68	1484	0.306	20
2	0.60 - 1.20	1	88	/	0.834	10
3	1.20 - 1.80	2	92	1832	1.398	20
4	1.80 - 2.40	2	72	1160	2.076	10
5	2.40 - 3.00	1	68	/	2.472	20
6	3.00 - 3.60	3	72	1320, 1844	3.18	10
7	3.60 - 4.20	1	92	/	3.768	20
8	4.20 - 4.80	2	72	1384	4.668	10
9	4.80 - 5.40	1	100	/	5.274	20
10	5.40 - 6.00	1	92	/	5.802	10
11	6.00 - 6.60	1	96	/	6.252	20
12	6.60 - 7.20	3	92	1364, 1348	6.732	10
13	7.20 - 7.80	3	72	1596, 1464	7.464	20
14	7.80 - 8.40	1	60	/	7.878	10
15	8.40 - 9.00	3	64	1444, 1224	8.508	20
16	9.00 - 9.60	1	100	/	9.438	10
17	9.60 - 10.20	3	72	1712, 1152	9.93	20
18	10.20 - 10.80	1	88	/	10.584	10
19	10.80 - 11.40	2	68	1368	11.022	20
20	11.40 - 12.00	1	88	/	11.544	10

Waveform29

Burst #	Burst Interval(s)	Number of Pulses	Pulse Width (us)	Pulse Spacing(us)	Pulse Start (s)	Chirp Width (MHZ)
1	0.00 - 0.60	1	72	/	0.348	20
2	0.60 - 1.20	1	92	/	1.068	10
3	1.20 - 1.80	2	60	1624	1.41	20
4	1.80 - 2.40	2	100	1336	2.082	10
5	2.40 - 3.00	3	72	1924, 1172	2.67	20
6	3.00 - 3.60	3	88	1488, 1396	3.438	10
7	3.60 - 4.20	1	76	/	4.008	20
8	4.20 - 4.80	1	72	/	4.674	10
9	4.80 - 5.40	2	92	1864	5.1	20
10	5.40 - 6.00	2	64	1748	5.604	10
11	6.00 - 6.60	2	84	1356	6.198	20
12	6.60 - 7.20	1	68	/	6.996	10
13	7.20 - 7.80	3	96	1236, 1988	7.542	20
14	7.80 - 8.40	3	56	1328, 1864	8.034	10
15	8.40 - 9.00	3	76	1160, 1264	8.538	20
16	9.00 - 9.60	2	96	1224	9.18	10
17	9.60 - 10.20	3	84	1136, 1364	10.002	20
18	10.20 - 10.80	1	56	/	10.302	10
19	10.80 - 11.40	2	64	1388	11.124	20
20	11.40 - 12.00	1	88	/	11.628	10



SIEMIC, INC.

Accessing global markets

Title: RF Test Report of Stryker Endoscopy
Model : P23366
To FCC DFS Test Report

Serial# SL12011902-STR-001_SYNK_Receiver (DFS)
Issue Date Jan 7th, 2013
Page 78 of 109
www.sieminc.com

Waveform 30

Burst #	Burst Interval(s)	Number of Pulses	Pulse Width (us)	Pulse Spacing(us)	Pulse Start (s)	Chirp Width (MHZ)
1	0.00 - 0.60	2	52	1352	0.12	20
2	0.60 - 1.20	1	100	/	0.876	10
3	1.20 - 1.80	1	96	/	1.314	20
4	1.80 - 2.40	3	60	1220, 1504	1.974	10
5	2.40 - 3.00	1	92	/	2.46	20
6	3.00 - 3.60	2	100	1100	3.45	10
7	3.60 - 4.20	1	88	/	3.99	20
8	4.20 - 4.80	1	68	/	4.428	10
9	4.80 - 5.40	2	72	1396	5.154	20
10	5.40 - 6.00	3	92	1240, 1216	5.67	10
11	6.00 - 6.60	1	72	/	6.21	20
12	6.60 - 7.20	1	92	/	6.858	10
13	7.20 - 7.80	2	96	1896	7.602	20
14	7.80 - 8.40	2	68	1552	7.926	10
15	8.40 - 9.00	1	64	/	8.838	20
16	9.00 - 9.60	1	60	/	9.396	10
17	9.60 - 10.20	3	72	1996, 1516	9.978	20
18	10.20 - 10.80	2	68	1992	10.518	10
19	10.80 - 11.40	3	60	1448, 1792	11.148	20
20	11.40 - 12.00	2	68	1156	11.736	10

Annex C. TEST SETUP AND SUPPORTING EQUIPMENT

EUT TEST CONDITIONS

Annex C. i. SUPPORTING EQUIPMENT DESCRIPTION

The following is a description of supporting equipment and details of cables used with the EUT.

Equipment Description (Including Brand Name)	Model & Serial Number	Cable Description (List Length, Type & Purpose)
PC Laptop / HP	N/A	Serial (From PC to DFS master & Client)
WISE 26" HDTV Display	VHW26110620	DVI
SYNK Transmitter	0240031010	RF cable
Multimedia Generator	ODSG-02C	DVI

Annex C.ii. EUT OPERATING CONDITIONS

The following is the description of how the EUT is exercised during testing.

Test	Description Of Operation
DFS Testing	The master and client traffic was setup for continuously streaming NTIA MPEG video clip.



SIEMIC, INC.

Accessing global markets

Title: RF Test Report of Stryker Endoscopy
Model : P23366
To FCC DFS Test Report

Serial# SL12011902-STR-001_SYNK_Receiver (DFS)
Issue Date Jan 7th, 2013
Page 81 of 109
www.siemic.com

Annex D User Manual, Block Diagram, Circuit Diagram

Please see attachment

Annex E SIEMIC ACCREDITATION

SIEMIC ACCREDITATION DETAILS: A2LA 17025 & ISO Guide 65 : 2742.01 , 2742.2



American Association for Laboratory Accreditation

Accredited Laboratory
A2LA has accredited
SIEMIC, INC.
Milpitas, CA
for technical competence in the field of
Electrical Testing

This laboratory is accredited in accordance with the recognized International Standard ISO/IEC 17025:2005 *General Requirements for the Competence of Testing and Calibration Laboratories*. This accreditation demonstrates technical competence for a defined scope and the operation of a laboratory quality management system (refer to joint ISO-ILAC-LAF Communiqué dated 8 January 2009).

Presented this 19th day of September 2012.



President & CEO
For the Accreditation Council
Certificate Number 2742.01
Valid to September 30, 2014



For the tests or types of tests to which this accreditation applies, please refer to the laboratory's Electrical Scope of Accreditation.



SIEMIC, Inc.

Accessing global markets

Title: RF Test Report of Stryker Endoscopy
Model : P23366
To: FCC DFS Test Report

Serial# SL12011902-STR-001_SYNK_Receiver (DFS)
Issue Date Jan 7th, 2013
Page 83 of 109
www.siemic.com



American Association for Laboratory Accreditation

SCOPE OF ACCREDITATION TO ISO/IEC 17025:2005

SIEMIC, INC.
dba SIEMIC LABORATORIES
775 Montague Expressway
Milpitas, CA 95035
Mr. Leslie Bai Phone: 408 526 1188 Email: leslie.bai@siemic.com
Mr. Snell Leong Phone: 408 526 1188 Email: snell.leong@siemic.com
www.siemic.com

ELECTRICAL

Valid to: September 30, 2014

Certificate Number: 2742.01

In recognition of the successful completion of the A2LA evaluation process, accreditation is granted to this laboratory to perform the following EMC, Product Safety, Radio and Telecommunication tests:

<u>Test Technology:</u>	<u>Test Method(s):</u>
EN & IEC – Emissions & Immunity	IEC/CISPR 11; EN 55011; IEC/CISPR 12; IEC/CISPR 20; EN 55020; IEC/CISPR 22; EN 55022; IEC/CISPR 24; EN 55024; EN 61000-6-1; EN 61000-6-2; EN 61000-6-3; EN 61000-6-4; EN 61204-3; EN 61326-1; EN 61326-2-1; EN 61326-2-2; EN 61326-2-3; EN 61326-2-4; EN 61326-2-5; EN 61000-3-2; EN 61000-3-3; EN 50081-1; EN 50081-2; EN 50082-1; IEC 61000-4-2; EN 61000-4-2; IEC 61000-4-3 (limited up to 2.7 GHz and 3V/m); EN 61000-4-3 (limited up to 2.7 GHz and 3V/m); IEC 61000-4-4; EN 61000-4-4; IEC 61000-4-5; EN 61000-4-5; IEC 61000-4-6; EN 61000-4-6; IEC 61000-4-8; EN 61000-4-8; IEC 61000-4-11; EN 61000-4-11; EN 50412-2-1; EN 50083-2; EN 50090-2-2; EN 50091-2; EN 50491-5-1; EN 50491-5-2; EN 50491-5-3; EN 50130-4; EN 50130-4 + A12; EN 12184; EN 55015; EN 61547; IEC 60601-1-2; CISPR 16-2-3

(A2LA Cert. No. 2742.01) 09/19/2012

Page 1 of 8

**SIEMIC, Inc.**

Accessing global markets

Title: RF Test Report of Stryker Endoscopy
 Model : P23366
 To: FCC DFS Test Report

Serial# SL12011902-STR-001_SYNK_Receiver (DFS)
 Issue Date Jan 7th, 2013
 Page 84 of 109
 www.sieminc.com

<u>Test Technology:</u>	<u>Test Method(s):</u>
Korea – Emissions & Immunity	<p>RRA Public Notification 2011-24; RRA Announce 2011-30; Annex 2 (KN 11); Annex 3 (KN 13); Annex 4 (KN 14-1); Annex 5 (KN 22); Annex 6 (KN 41); Annex 7 (KN 50); Annex 9 (KN 15); Annex 10 (KN 19); Annex 11 (KN 60); Annex 1-1 (KN 16-1-1); Annex 1-2 (KN 16-1-2); Annex 1-3 (KN 16-1-3); Annex 1-4 (KN 16-1-4); Annex 1-5 (KN 16-1-5); Annex 1-6 (KN 16-2-1); Annex 1-7 (KN 16-2-2); Annex 1-8 (KN 16-2-3); Annex 1-9 (KN 16-2-4); Annex 8-5 (KN 301-489-06); Annex 8-6 (KN 301-489-13); Annex 8-7 (KN 301-489-05); Annex 8-8 (KN 301-489-03); Annex 8-9 (KN 301-489-09); Annex 8-10 (KN 301-489-26); Annex 8-11 (KN 301-489-18); Annex 8-12 (KN 301-489-15); Annex 8-13 (KN 301-489-02); Annex 8-14 (KN 301-489-27); Annex 8-15 (KN 301-489-32); Annex 8-16 (KN 301-489-20); Annex 8-17 (KN 60945)</p> <p>RRA Public Notification 2011-25; RRA Announce 2011-31; Annex 1-1 (KN 61000-4-2); Annex 1-2 (KN 61000-4-3); Annex 1-3 (KN 61000-4-4); Annex 1-4 (KN 61000-4-5); Annex 1-5 (KN 61000-4-6); Annex 1-6 (KN 61000-4-8); Annex 1-7 (KN 61000-4-11); Annex 2 (KN 60601-1-2); Annex 3 (KN 20); Annex 4 (KN 14-2); Annex 5 (KN 24); Annex 6 (KN 41); Annex 7 (KN 51); Annex 8-1 (KN 301-489-01); Annex 8-2(KN 301-489-07); Annex 8-3 (KN 301-489-17); Annex 8-4(KN 301-489-24);</p>
US / FCC - Emissions	<p>FCC Method 47 CFR Part 18, FCC Report and Order ET Docket 98-153 (FCC 02-48); FCC Method 47 CFR Parts15, including Subpart G, using FCC Order 04-425; ANSI C63.4 (2003); ANSI C63.4 (2009); ANSI C63.10 (2009); ANSI C63.4 (2003) with FCC Method 47 CFR Part 11; ANSI C63.4 (2003) with FCC Method 47 CFR Part 15, Subpart E; ANSI C63.4 (2003) with FCC Method 47 CFR Part 15, Subpart C; ANSI C63.4 (2003) and DA 02-2138; ANSI C63.4 (2003) with FCC Method 47 CFR Part 15, Subpart B</p>
Canada – Emissions	ICES-001; ICES-002; ICES-003; ICES-005; ICES-006
Vietnam – Emission & Immunity	TCN 68-193:2003; TCN 68-196:2001; TCVN 7189:2002; TCVN 7189:2009 (CISPR 22:2006)
Australia / New Zealand – Emissions and Immunity	AS/NZS 1044; AS/NZS 2279.3; AS/NZS 3548; AS/NZS 4251.1; AS/NZS 4251.2; AS/NZS CISPR 11; AS/NZS CISPR 14.1; AS/NZS CISPR 22; AS/NZS CISPR 24; AS/NZS 61000.3.2; AS/NZS 61000.3.3; AS/NZS 61000.6.3; AS/NZS 61000.6.4
Japan – Emissions	JEITA IT-3001; VCCI-V-3 (up to 6 GHz)
China – Emissions	GB9254; GB17625.1



<u>Test Technology:</u>	<u>Test Method(s):</u>
Taiwan – Emissions	CNS 13438 (up to 6 GHz); CNS 13783-1; CNS 13803; CNS 13439
Singapore – Emissions & Immunity	IDA TS EMC; CISPR 22; IEC 61000-4-2; IEC 61000-4-3; IEC 61000-4-4; IEC 61000-4-5; IEC 61000-4-6
FCC – Unlicensed Radio A1 to A4	<p>A1: 47 CFR Parts 11 (Emergency Alert System (EAS)), 15 (Radio Frequency Devices) and 18 (Industrial, Scientific, and Medical Equipment); FCC OST/MP-5(1986); ANSI C63.4(2003); ANSI C63.4(2009); ANSI C63.10(2009)</p> <p>A2: 47 CFR Part 15 (Radio Frequency Devices); ANSI C63.4(2003); ANSI C63.4(2009); ANSI C63.10(2009)</p> <p>A3: 47 CFR Part 15 (Radio Frequency Devices); ANSI C63.17:2006; ANSI C63.10(2009); IEEE Std 1528-2003 + A1; Std IEEE 528A:2005</p> <p>A4: 47 CFR Part 15 (Radio Frequency Devices); ANSI C63.10(2009); IEEE Std 1528-2003 + A1; Std IEEE 1528A:2005</p>
FCC – Licensed Radio B1 to B4	<p>B1: 47 CFR Parts 2 (Frequency Allocations and Radio Treaty Matters; General Rules and Regulations), 22 (Public Mobile Services), 24 (Personal Communications Services), 25 (Satellite Communications), and 27 (Miscellaneous Wireless Communications Services); ANSI/TIA-603-C (2004), ANSI/TIA-603-D(2010), Land Mobile FM or PM Communications Equipment Measurement and Performance Standard; IEEE Std 1528:2003 + Ad1; Std IEEE 1528A:2005</p> <p>B2: 47 CFR Parts 2 (Frequency Allocations and Radio Treaty Matters; General Rules and Regulations), 22 (Public Mobile Services), 74 (Experimental Radio Auxiliary, Special Broadcast and Other Program Distributional Services), 90 (Private Land Mobile Radio Services), 95 (Personal Radio Services), and 97 (Amateur Radio Services); ANSI/TIA-603-C (2004), ANSI/TIA-603-D(2010), Land Mobile FM or PM Communications Equipment Measurement and Performance Standard</p> <p>B3: 47 CFR Parts 2 (Frequency Allocations and Radio Treaty Matters; General Rules and Regulations); 80 (Stations in the Maritime Services), 87 (Aviation Services); ANSI/TIA-603-C (2004), ANSI/TIA-603-D(2010), Land Mobile FM or PM Communications Equipment Measurement and Performance Standard</p> <p>B4: 47 CFR Parts 2 (Frequency Allocations and Radio Treaty Matters; General Rules and Regulations); 27 (Broadband Radio Services (BRS) and Educational Broadband Services (EBS)), 74 (Experimental Radio Auxiliary, Special Broadcast and Other Program Distributional Services), and 101 (Fixed Microwave Services); ANSI/TIA-603-C (2004), ANSI/TIA-603-D(2010), Land Mobile FM or PM Communications Equipment Measurement and Performance Standard</p>



<u>Test Technology:</u>	<u>Test Method(s):</u>
Canada – Radio	RSS 102; RSS 111; RSS 112; RSS 117; RSS 118; RSS 119; RSS 123; RSS 125; RSS 127; RSS 129; RSS 131; RSS 132; RSS 133; RSS 134; RSS 135; RSS 136; RSS 137; RSS 138; RSS 139; RSS 141; RSS 142; RSS 170; RSS 181; RSS 182; RSS 191; RSS 192; RSS 194; RSS 195; RSS 196; RSS 197; RSS 199; RSS 210; RSS 220; RSS 213; RSS 215; RSS 243; RSS 287; RSS 288; RSS 310; RSS Gen
CE – Radio	EN 301 502; EN 301 511; EN 301 526; EN 301 681; EN 301 721; EN 301 751; EN 301 753; EN 301 783-2; EN 301 796; EN 301 797; EN 301 840-2; EN 301 843-1; EN 301 843-4; EN 301 843-5; EN 301 893; EN 301 908-01; EN 301 908-02; EN 301 908-03; EN 301 908-04; EN 301 908-05; EN 301 908-06; EN 301 908-07; EN 301 908-08; EN 301 908-09; EN 301 908-10; EN 301 908-11; EN 301 929-2; EN 301 997-2; EN 302 018-2; EN 302 054-2; EN 302 064-2; EN 302 066-2; EN 302 077-2; EN 302 186; EN 302 195-2; EN 302 217-3; EN 302 245-2; EN 302 288-2; EN 302 291-2; EN 302 296; EN 302 297; EN 302 326-2; EN 302 326-3; EN 302 340; EN 302 372-2; EN 302 426; EN 302 454-2; EN 302 480; EN 302 502; EN 302 510-2; EN 302 217-4-2; EN 300 224-1; EN 300 279; EN 300 339; EN 300 385; EN 301 839-2; EN 301 843-6; EN 302 017-2; EN 302 208-2; EN 302 217-2-2; ETS 300 329; ETS 300 445; ETS 300 446; ETS 300 683; ETS 300 826; ETS EN 300 328; ETSI EN 300 086-2; EN 302 217-1; EN 302 217-2-1; EN 302 217-4-1; EN 302 288-1; EN 302 908-12; EN 302 326-1; EN 301 929-1; EN 301 997-1; EN 300 224-2; EN 301 839-1; EN 301 843-1; EN 301 843-2; EN 301 843-3; EN 301 843-4; EN 301 843-5; EN 302 017-1; EN 302 208-1; EN 300 086-1; EN 300 113-1; EN 300 224-1; EN 300 341-1; EN 302 291-1; EN 302 500-1; EN 302 500-2; ETSI EN 300 113-2; ETSI EN 300 197; ETSI EN 300 198; ETSI EN 300 219-1; ETSI EN 300 219-2; ETSI EN 300 220-1; ETSI EN 300 220-2; ETSI EN 300 220-3; ETSI EN 300 224-2; ETSI EN 300 296-1; ETSI EN 300 296-2; ETSI EN 300 328-1; ETSI EN 300 328-2; ETSI EN 300 330; ETSI EN 300 330-1; ETSI EN 300 330-2; ETSI EN 300 341-2; ETSI EN 300 373-1; ETSI EN 300 373-2; ETSI EN 300 373-3; ETSI EN 300 390-1; ETSI EN 300 390-2; ETSI EN 300 422-1; ETSI EN 300 422-2; ETSI EN 300 431; ETSI EN 300 440-1; ETSI EN 300 440-2; ETSI EN 300 454-1; ETSI EN 300 454-2; ETSI EN 300 718-2; ETSI EN 301 021; ETSI EN 301 166-1; ETSI EN 301 166-2; ETSI EN 301 178-2; ETSI EN 301 213-1; ETSI EN 301 213-2; ETSI EN 301 213-3; ETSI EN 301 213-4; ETSI EN 301 213-5; ETSI EN 301 357-1; ETSI EN 301 357-2; ETSI EN 301 390; ETSI EN 301 459; ETSI EN 301 489-01 (excluding section 9.6); ETSI EN 301 489-02; ETSI EN 301 489-03; ETSI EN 301 489-04; ETSI EN 301 489-05; ETSI EN 301 489-06; ETSI EN 301 489-07; ETSI EN 301 489-08; ETSI EN 301 489-09; ETSI EN 301 489-10; ETSI EN 301 489-11; ETSI EN 301 489-12; ETSI EN 301 489-13; ETSI EN 301 489-14; ETSI EN 301 489-15; ETSI EN 301 489-16; ETSI EN 301 489-17; ETSI EN 301 489-18; ETSI EN 301 489-19; ETSI EN 301 489-20; ETSI EN 301 489-22; ETSI EN 301 489-23; ETSI EN 301 489-24; ETSI EN 301 489-25; ETSI EN 301 489-26;

**SIEMIC, Inc.**

Accessing global markets

Title: RF Test Report of Stryker Endoscopy
 Model : P23366
 To: FCC DFS Test Report

Serial# SL12011902-STR-001_SYNK_Receiver (DFS)
 Issue Date Jan 7th, 2013
 Page 87 of 109
 www.sieminc.com

Test Technology:	Test Method(s):
CE – Radio (continued)	ETSI EN 301 489-27; ETSI EN 301 489-28; ETSI EN 301 489-31; ETSI EN 301 489-32; IEC 60945; EN 302 480
IDA – Radio	IDA TS AR; IDA TS CT-CTS; IDA TS GMPCS; IDA TS LMR; IDA TS RPG; IDA TS SRD; IDA TS UWB; IDA TS WBA; IDA TS CMT; IDA TS CBS
Vietnam – Radio	QCVN 54:2011/BTTTT; TCN 68-242:2006; QCVN 11:2010/BTTTT; QCVN 17:2010/BTTTT
Korea – Radio	KCC Public Notification 2012-12; RRA Announce 2011-32; RRA Public Notification 2010-46
Taiwan – Radio	LP0002; PLMN07; PLMN01; PLMN08
Australia - New Zealand – Radio	AS 2772.2; AS/NZS 4281; AS/NZS 4268; AS/NZS 4280.1; AS/NZS 4583; AS/NZS 4280.2; AS/NZS 4281; AS/NZS 4295; AS/NZS 4582; AS/NZS 4769.1; AS/NZS 4769.2; AS/NZS 4770; AS/NZS 4771
Hong Kong – Radio	HKCA 1002; HKCA 1007; HKCA 1008; HKCA 1010; HKCA 1015; HKCA 1016; HKCA 1020; HKCA 1022; HKCA 1026; HKCA 1027; HKCA 1029; HKCA 1030; HKCA 1031; HKCA 1032; HKCA 1033; HKCA 1034; HKCA 1035; HKCA 1036; HKCA 1037; HKCA 1039; HKCA 1041; HKCA 1042; HKCA 1043; HKCA 1044; HKCA 1046; HKCA 1047; HKCA 1048; HKCA 1049; HKCA 1051; HKCA1052; HKCA1053; HKCA 1054; HKCA 1055; HKCA 1056; HKCA 1057; HKCA 1061
FCC Telephone Terminal Equipment Scope C1	TIA-968-B; FCC Rule Part 68; 47 CFR Part 68.316; 47 CFR Part 68.317; ANSI/TIA/EIA-464-C; TIA-810-B; T1.TRQ6 (2002); TCB-31-B (1998); TIA-470.110-C; TIA-920
Canada – Telecom	CS-03 Part I Issue 9:2010. Amendment 4; CS-03 Part II Issue 9:2004; CS-03 Part V Issue 9:2009 Amendment 1; CS-03 Part VI Issue 9:2004; CS-03 Part VII Issue 9:2006 Amendment 3; CS-03 Part VIII Issue 9:2009 Amendment 4
Europe – Telecom	TBR 2; 01-1997; TBR 004 Ed.1.95 + A1 (97); TBR 1; TBR 3; TBR 12; A1 01-1996; TBR 013 ed.1; TBR 024 ed.1; TBR 25; TBR 38 ed.1; TBR 021; ETSI ES 203 021-05 ; ETSI ES 203 021-2 ; ETSI ES 021-3; ETSI EG 201 121; ETSI EN 301 437; ETSI TS 101 270-1; ITU-T Recommendation Q.920; ITU-T Recommendation Q.920 – Amendment 1; ITU-T Recommendation Q.921; ITU-T Recommendation Q.921 – Amendment 1; ITU-T Recommendation Q.931; ITU-T Recommendation Q.931 – Amendment 1; Erratum 1 (02/2003) ITU-T Recommendation Q.931 (05/1998);



<u>Test Technology:</u>	<u>Test Method(s):</u>
Europe – Telecom (cont'd)	ISDN User Network Interface Layer 3 Specification for Basic Call Control; ITU-T Recommendation P.300
Australia – Telecom Australia – Telecom	AS/CA S003.1:2010; AS/CA S002:2011; AS/ACIF S004:2008; AS/CA S042.1:2011; AS/CA S003.2:2010; AS/CA S003.3:2010; AS/CA S004:2010; AS/ACIF S006:2008; AS/ACIF S041.1:2009 AS/ACIF S041.2:2009; AS/ACIF S041.3:2009; AS/ACIF S042.1:2008; AS/ACIF S043.2:2008; AS/ACIF S043.3:2008; AS/ACIF S002:05; AS/ACIF S003:06; AS/ACIF S004:08; AS/ACIF S006:01; AS/ACIF S016:01; AS/ACIF S031:01; AS/ACIF S038:01; AS/ACIF S040:01; AS/ACIF S041:05; AS/ACIF S043.2:06
New Zealand – Telecom	PTC200:2006; PTC200 Issue No.2:97 + A1(980); PTC220; PTC273:2007; TNA 115; TNA 117
Singapore – Telecom	IDA TS ADSL; IDA TS DLCN; IDA TS ISDN BA; IDA TS ISDN PRA; IDA TS BISDN; IDA TS-PSTN; IDA TS ACLIP; IDA TS CM
Hong Kong – Telecom	HKCA 2011; HKCA 2012; HKCA 2013; HKCA 2014; HKCA 2015; HKCA 2017; HKCA 2018; HKCA 2019; HKCA 2022; HKCA 2023; HKCA 2024; HKCA 2026; HKCA 2027; HKCA 2028; HKCA 2029; HKCA 2030; HKCA 2031; HKCA 2032; HKCA 2033
Vietnam – Telecom	QCVN 10:2010/BTTTT; QCVN 19:2010/BTTTT; TCN 68-189:2000; QCVN 18:2010/BTTTT; TCVN 7317:2003 (CISPR 24:1997); QCVN 12:2010/BTTTT; QCVN 13:2010/BTTTT; QCVN 55:2011/BTTTT; QCVN 15:2010/BTTTT
Korea – Telecom	Presidential Decree 21098; RRA Public Notification 2010-36; RRA Public Notification 2009-38; RRA Announce 2011-2; Annex 1 (RRA Announce 2011-2); Annex 3 (RRA Announce 2011-2); Annex 5 (RRA Announce 2011-2); Annex 6 (RRA Announce 2011-2)

**SIEMIC, INC.**

Accessing global markets

Title: RF Test Report of Stryker Endoscopy
 Model : P23366
 To: FCC DFS Test Report

Serial# SL12011902-STR-001_SYNK_Receiver (DFS)
 Issue Date Jan 7th, 2013
 Page 89 of 109
 www.sieminc.com

Test Technology:	Test Method(s):
China – Telecom	YD/T 514-1-98; YD/T 1277.1-2003; GB/T 17904.1-1999; GB/T 17904.2-1999; GB/T 17154.1-1997; GB/T 17154.2-1997; YD/T1091-2000; YD/T1006-1999; GB/T 17789-1999
Taiwan – Telecom	PSTN01:2007; ADSL01:08; ID0002:2007; IS6100: 93
Japan – Telecom	JATE Blue Book, Green Book; Ministerial Ordinance of the Ministry of Posts and Telecommunications No. 31 of April 1, 1985 (last amended on March 22 2004); Ordinance Concerning Technical Conditions Compliance Approval etc. of Terminal Equipment (amended by the Ministerial Ordinance of the MIC No.92 of October 25, 2010) and Ordinance Concerning Terminal Facilities etc. (amended by the Ministerial Ordinance of the MIC No. 91 of October 25, 2010)
South Africa – Telecom	DPT-TE-001; TE-002; TE-003; TE-004; TE-005; TE-006; TE-007; TE-008; TE-009; TE-010; TE-012 (telephone interface); TE-013 (telephone interface); TE-014; TE-015; TE-018; SWS-001; SWS-002; SWS-003; SWS-004; SWS-005; SWS-006; SWS-007; SWS-008; SWS-009; SWS-010
Israel – Telecom	Israel MoC Spe. 23/96
Mexico – Telecom	NOM-151-SCT1-1999; NOM-152-SCT1-1999
Argentina – Telecom	CNC-ST2-44-01
Brazil – Telecom	Resolution 392-2005
International Telecom Union	ITU-T-G.703:01; ITU-T-G.823:93; ITU-T G.824; ITU-T G.825; ITU-T-G.991.2; ITU-T-G.992.1; ITU-T-G.992.3; ITU-T-G.992.5; ITU-T-G.993.1
Product Safety	IEC 60950-1; EN 60950-1; UL 60950-1; IEC 60601-1-1; CAN/CSA 22.2 NO. 60950-1-03; SS-EN 60950-1; AS/NZ 60950-1, (voltage surge testing up to 6kV, excluding Annex A, H, and Y); CNS 14336, CNS 14408; GB4943; President Notice 20664; RRA Public Notification 2011-14; RRA Announce 2011-3; Annex 1(RRA Announce 2011-3); QCVN 22:2010/BTTTT; SABS IEC 60950; IEC/EN 61558; IEC/EN 61558-2-7; EN 62115; IEC 60215; EN 60958; EN 60598; IEC 215 (1987) + A1 (1992) + A2 (1994)
Japan - Radio	ARIB STD-T81; ARIB STD-T66; RCR STD-1; RCR STD-29; ARIB STD-T94 Fascicle 1; ARIB STD-T90; ARIB STD-T89; RCR STD-33
SAR & HAC	IEEE P1528:2003 + Ad1; IEEE 1528A:2005; FCC OET Bulletin 65 Supplement C; FCC OET Bulletin 65; ANSI C95; ANSI C63.19; FCC 47 CFR 20.19; H46-2/99-273E; EN 50360; EN 50361; IEC62209-1; IEC 62209-2; EN 50371; EN 50383; EN 50357; EN 50364;



<u>Test Technology:</u>	<u>Test Method(s):</u>
SAR & HAC (<i>cont'd</i>)	KCC Public Notification 2009-27; RRA Public Notification 2010-45; KCC Public Notification 2012-2; CNS 14958-1; CNS 14959; NZS 2772.1; Resolution N 533; AS/NZS 2772.2:2011
Japan – Notification No. 88 of MIC 2004	
Table No 13	CB Radio
Table No 21	Cordless Telephone
Table Nos 22-1 thru 22-17	Low Power Radio Equipment
Table No 36	Low Power Security System
Table No 43	Low Power Data Communication in the 2.4 GHz Band
Table No 44	Low Power Data Communication in the 2.4 GHz Band
Table No 45	Low Power Data Communication in the 5.2, 5.3, 5.6 GHz Bands
Table No 46	Low Power Data Communication in the 25 and 27 GHz Bands
Table No 47	Base Station for 5 GHz Band Wireless Access System
Table No 47	Base Station for 5 GHz Band Wireless Access System (low spurious type)
Table No 47	Land Mobile Relay for 5 GHz Band Wireless Access System (limited for use in special zones)
Table No 47	Land Mobile Relay for 5 GHz Band Wireless Access System (limited for use in special zones, low spurious type)
Table No 47	Land Mobile Relay for 5 GHz Band Wireless Access System
Table No 47	Land Mobile Relay for 5 GHz Band Wireless Access System (low spurious type)
Table No 47	Land Mobile Relay for 5 GHz Band Wireless Access System (low power type)
Table No 50	Digital Cordless Telephone
Table No 50	PHS Base Station
Table No 50	PHS Land Mobile Station
Table No 50	PHS Relay Station
Table No 50	PHS Test Station
Table No 64	Mobile Station for Dedicated Short Range Communication Systems
Table No 64	Base Station for Dedicated Short Range Communication Systems
Table No 64	Test Station for Dedicated Short Range Communication Systems
Table No 70	UWB (Ultra Wide Band) Radio System

*Limitations for listed standards are indicated by italics and Scope excludes protocol sections of applicable standards.



SIEMIC, Inc.

Accessing global markets

Title: RF Test Report of Stryker Endoscopy
Model : P23366
To: FCC DFS Test Report

Serial# SL12011902-STR-001_SYNK_Receiver (DFS)
Issue Date Jan 7th, 2013
Page 91 of 109
www.sieminc.com



American Association for Laboratory Accreditation

Accredited Product Certification Body

A2LA has accredited

SIEMIC, INC.

Milpitas, CA

for technical competence as a

Product Certification Body

This product certification body is accredited in accordance with the recognized International Standard ISO/IEC Guide 65:1996 *General requirements for bodies operating product certification systems*. This accreditation demonstrates technical competence for a defined scope and the operation of a quality management system.

Presented this 19th day of September 2012.

President & CEO
For the Accreditation Council
Certificate Number 2742.02
Valid to September 30, 2014



For the product certification schemes to which this accreditation applies, please refer to the organization's Product Certification Scope of Accreditation.



SIEMIC, Inc.

Accessing global markets

Title: RF Test Report of Stryker Endoscopy
Model : P23366
To: FCC DFS Test Report

Serial# SL12011902-STR-001_SYNK_Receiver (DFS)
Issue Date Jan 7th, 2013
Page 92 of 109
www.siemic.com



American Association for Laboratory Accreditation

SCOPE OF ACCREDITATION TO ISO/IEC GUIDE 65:1996

SIEMIC, INC.
775 Montague Expressway
Milpitas, CA 95035
Mr. Suel Leong (Authorized Representative) Phone: 408 526 1188
www.siemic.com

PRODUCT CERTIFICATION CONFORMITY ASSESSMENT BODY (CAB)

Valid to: September 30, 2014

Certificate Number: 2742.02

In recognition of the successful completion of the A2LA Certification Body Accreditation Program evaluation, including the US Federal Communications Commission (FCC), Industry Canada (IC), Singapore (IDA), Hong Kong (OFCA) and Japan (MIC) requirements for the indicated types of product certifications, accreditation is granted to this organization to certify products in accordance with the following product certification schemes:

Economy:

Scope:

Federal Communication Commission - (FCC)

Unlicensed Radio Frequency Devices	A1, A2, A3, A4
Licensed Radio Frequency Devices	B1, B2, B3, B4
Telephone Terminal Equipment	C

**Please refer to FCC TCB Program Rules and Responsibilities, released January 6, 2011, detailing scopes, roles and responsibilities. [TCB Program Rules and Responsibilities](http://www.fcc.gov/etf/tcb/tcb-program-rules-and-responsibilities)*

Industry Canada - (IC)

Radio	Scope 1-Licence-Exempt Radio Frequency Devices; Scope 2-Licensed Personal Mobile Radio Services; Scope 3-Licensed General Mobile & Fixed Radio Services; Scope 4-Licensed Maritime & Aviation Radio Services; Scope 5-Licensed Fixed Microwave Radio Services;
-------	--

**Please refer to Industry Canada (IC) website at: <http://www.ic.gc.ca/eic/site/smt-gst.nsf/eng/sff9888.html>*



IDA – Singapore

Line Terminal Equipment

All Technical Specifications for Line Terminal Equipment – Table 1 of IDA MRA Recognition Scheme: 2011, Annex 2

Radio-Communication Equipment

All Technical Specifications for Radio-Communication Equipment – Table 2 of IDA MRA Recognition Scheme: 2011, Annex 2

**Please refer to Info-Communication Development Authority (IDA) Singapore website at:
http://www.ida.gov.sg/doc/Policies%20and%20Regulation/Policies_and_Regulation_Level2_20060609145118/MRARecScheme.pdf*

OFCA – Hong Kong

Radio Equipment

HKCA 1001, 1002, 1003, 1004, 1005, 1006, 1007, 1008, 1010, 1015, 1016, 1019, 1020, 1022, 1026, 1027, 1033, 1034, 1035, 1036, 1037, 1038, 1039, 1041, 1042, 1043, 1044, 1045, 1046, 1047, 1048, 1049, 1050, 1052, 1053, 1054, 1056, 1057, 1061

**Please refer to the Office of the Communications Authority's website at:
[Radio Equipment Specifications \(HKCA 10XX\)](#)*

Fixed Network Equipment

HKCA 2001, 2005, 2011, 2012, 2013, 2014, 2015, 2016, 2017, 2018, 2019, 2020, 2021, 2022, 2023, 2024, 2026, 2027, 2028, 2029, 2030, 2031, 2032, 2033, 2034, 2035, 2036, 2037, 2040, 2041, 2102, 2103, 2104, 2108, 2201, 2202, 2203, 2204

**Please refer to the Office of the Communications Authority's website at:
[Fixed Network Equipment Specifications \(HKCA 2XXX\)](#)*

MIC – Japan

Telecommunications Business Law (Terminal Equipment)

Scope A1 - Terminal Equipment for the Purpose of Calls

Radio Law (Radio Equipment)

Scope B1 - Specified Radio Equipment specified in, Article 38-2-2, paragraph 1, item 1 of the Radio Law



SIEMIC, Inc.

Accessing global markets

Title: RF Test Report of Stryker Endoscopy
Model : P23366
To: FCC DFS Test Report

Serial# SL12011902-STR-001_SYNK_Receiver (DFS)
Issue Date Jan 7th, 2013
Page 94 of 109
www.siemic.com

SIEMIC ACCREDITATION DETAILS: FCC Test Site Registration No. 881796

FEDERAL COMMUNICATIONS COMMISSION

**Laboratory Division
7435 Oakland Mills Road
Columbia, MD 21046**

August 03, 2012

Registration Number: 881796

SIEMIC Labs
775 Montague Expressway,
Milpitas, CA 95035

Attention: Leslie BAI

Re: Measurement facility located at 775 Montague Expressway, Milpitas, CA 95035
Anechoic chamber (10 meters)
Date of Listing: August 03, 2012

Dear Sir or Madam:

Your request for registration of the subject measurement facility has been reviewed and found to be in compliance with the requirements of Section 2.948 of the FCC rules. The information has, therefore, been placed on file and the name of your organization added to the list of facilities whose measurement data will be accepted in conjunction with applications for Certification under Parts 15 or 18 of the Commission's Rules. Please note that the file must be updated for any changes made to the facility and the registration must be renewed at least every three years.

Measurement facilities that have indicated that they are available to the public to perform measurement services on a fee basis may be found on the FCC website www.fcc.gov under E-Filing, OET Equipment Authorization Electronic Filing, Test Firms.

Sincerely,

Katie Hawkins
Electronics Engineer

SIEMIC ACCREDITATION DETAILS: Industry of Canada CAB ID : US0160



UNITED STATES DEPARTMENT OF COMMERCE
National Institute of Standards and Technology
Gaithersburg, Maryland 20899

March 4, 2009

Mr. Leslie Bai
SIEMIC, Inc.
2206 Ringwood Avenue
San Jose, CA 95131

Dear Mr. Bai:

NIST is pleased to inform you that your laboratory has been recognized by Industry Canada (IC), under the Asia Pacific Economic Cooperation for Telecommunications Equipment Mutual Recognition Arrangement (APEC Tel MRA). Your laboratory is now designated to act as a Conformity Assessment Body (CAB) under Appendix B, **Phase I** Procedures, of the APEC Tel MRA. The pertinent information about your laboratory's designation is as follows:

CAB Name: SIEMIC, Inc.
Physical Location: 2206 Ringwood Avenue, San Jose, CA 95131 USA
Identification No.: US0160
Recognized Scope: CS-03 Part I, II, V, VI, VII and VIII

You may submit test data to IC to verify that the equipment to be imported into Canada satisfies the applicable requirements. The designation of your organization will remain in force as long as its accreditation for the designated scope remains valid and comply with the designation requirements.

Recognized CABs are listed on the NIST website at <http://ts.nist.gov/mra>. Please contact Ms. Ramona Saar at (301) 975-5521 or ramona.saar@nist.gov if you have any questions.

Sincerely,

David F. Alderman
Group Leader, Standards Coordination and Conformity Group
Standards Services Division

Enclosure

cc: CAB Program Manager



SIEMIC, INC.

Accessing global markets

Title: RF Test Report of Stryker Endoscopy
Model : P23366
To: FCC DFS Test Report

Serial# SL12011902-STR-001_SYNK_Receiver (DFS)
Issue Date Jan 7th, 2013
Page 96 of 109
www.siemec.com

SIEMIC ACCREDITATION DETAILS: Industry of Canada Test Site Registration No. 4842-1

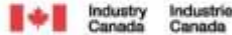

July 03, 2012

OUR FILE: 46405-4842
Submission No: 157820

Siemic Inc.
775 Montague Expressway
Milpitas, CA, 95035
United States

Attention:

Dear Sir/Madame: Snell Leong

The Bureau has received your application for the renewal of 3/10m alternative test site. Be advised that the information received was satisfactory to Industry Canada. The following number(s) is now associated to the site(s) for which registration / renewal was sought (**Site# 4842D-2**). Please reference the appropriate site number in the body of test reports containing measurements performed on the site. In addition, please keep for your records the following information;

- The company address code associated to the site(s) located at the above address is: **4842D**

Furthermore, to obtain or renew a unique site number, the applicant shall demonstrate that the site has been accredited to ANSI C63.4-2003 or later. A scope of accreditation indicating the accreditation by a recognized accreditation body to ANSI C63.4-2003 or later shall be accepted. Please indicate in a letter the previous assigned site number if applicable and the type of site (example: 3 metre OATS or 3 metre chamber). If the test facility is not accredited to ANSI C63.4-2003 or later, the test facility shall submit test data demonstrating full compliance with the ANSI standard. The Bureau will evaluate the filing to determine if recognition shall be granted.

The frequency for re-validation of the test site and the information that is required to be filed or retained by the testing party shall comply with the requirements established by the accrediting organization. However, in all cases, test site re-validation shall occur on an interval not to exceed **three years**. There is no fee or form associated with an OATS filing. OATS submissions are encouraged to be submitted electronically to the Bureau using the following URL;

http://strategis.ic.gc.ca/epic/internet/inceb-bhst.nsf/en/h_tt00052e.html.

If you have any questions, you may contact the Bureau by e-mail at certification.bureau@ic.gc.ca Please reference our file and submission number above for all correspondence.

Yours sincerely,

Dalwinder Gill
For: Wireless Laboratory Manager
Certification and Engineering Bureau
3701 Carling Ave., Building 94
P.O. Box 11490, Station "H"
Ottawa, Ontario K2H 8S2
Email: dalwinder.gill@ic.gc.ca
Tel. No. (613) 998-8363
Fax. No. (613) 990-4752



SIEMIC, Inc.

Accessing global markets

Title: RF Test Report of Stryker Endoscopy
Model : P23366
To: FCC DFS Test Report

Serial# SL12011902-STR-001_SYNK_Receiver (DFS)
Issue Date Jan 7th, 2013
Page 97 of 109
www.siemec.com

SIEMIC ACCREDITATION DETAILS: FCC DOC CAB Recognition : US1109

FEDERAL COMMUNICATIONS COMMISSION

**Laboratory Division
7435 Oakland Mills Road
Columbia, MD 21046**

August 28, 2008

Siemic Laboratories
2206 Ringwood Ave.,
San Jose, CA 95131

Attention: Leslie Bai

Re: Accreditation of Siemic Laboratories
Designation Number: US1109
Test Firm Registration #: 540430

Dear Sir or Madam:

We have been notified by American Association for Laboratory Accreditation that Siemic Laboratories has been accredited as a Conformity Assessment Body (CAB).

At this time Siemic Laboratories is hereby designated to perform compliance testing on equipment subject to Declaration Of Conformity (DOC) and Certification under Parts 15 and 18 of the Commission's Rules.

This designation will expire upon expiration of the accreditation or notification of withdrawal of designation.

Sincerely,

George Tannahill
Electronics Engineer

SIEMIC ACCREDITATION DETAILS: Australia CAB ID : US0160



UNITED STATES DEPARTMENT OF COMMERCE
National Institute of Standards and Technology
Gaithersburg, Maryland 20899

November 20, 2008

Mr. Leslie Bai
SIEMIC, Inc.
2206 Ringwood Avenue
San Jose, CA 95131

Dear Mr. Bai:

NIST is pleased to inform you that your laboratory has been recognized by the Australian Communications and Media Authority (ACMA) under the Asia Pacific Economic Cooperation for Telecommunications Equipment Mutual Recognition Arrangement (APEC Tel MRA). Your laboratory is now designated to act as a Conformity Assessment Body (CAB) under Appendix B, **Phase I** Procedures, of the APEC Tel MRA. The pertinent information about your laboratory's designation is as follows:

CAB Name: Siemic, Inc.
Physical Location: 2206 Ringwood Avenue, San Jose, CA 95131
Identification No.: US0160
Recognized Scope: EMC: AS/NZS 4251.1 (until 5/31/2009), AS/NZS 4251.2 (until 5/31/2009), AS/NZS CISPR 11, AS/NZS CISPR 14.1, AS/NZS CISPR 22, AS/NZS 61000.6.3, AS/NZS 61000.6.4
Radiocommunications: AS/NZS 4281, AS/NZS 4268, AS/NZS 4280.1, AS/NZS 4280.2, AS/NZS 4295, AS/NZS 4582, AS/NZS 4583, AS/NZS 4769.1, AS/NZS 4769.2, AS/NZS 4770, AS/NZS 4771
Telecommunications: AS/ACIF S002:05, AS/ACIF S003:06, AS/ACIF S004:06, AS/ACIF S006:01, AS/ACIF S016:01, AS/ACIF S031:01, AS/ACIF S038:01, AS/ACIF S040:01, AS/ACIF S041:05, AS/ACIF S043.2:06, AS/NZS 60950.1

You may submit test data to ACMA to verify that the equipment to be imported into Australia satisfies the applicable requirements. The designation of your organization will remain in force as long as its accreditation for the designated scope remains valid and comply with the designation requirements. Recognized CABs are listed on the NIST website at <http://ts.nist.gov/mra>. Please contact Ms. Ramona Saar, at (301) 975-5521 or ramona.saar@nist.gov if you have questions.

Sincerely,

David F. Alderman
Group Leader, Standards Coordination and Conformity Group
Standards Services Division

Enclosure

cc: Snell Leong, Siemic, Inc.; Ramona Saar, NIST





SIEMIC, Inc.

Accessing global markets

Title: RF Test Report of Stryker Endoscopy
Model : P23366
To: FCC DFS Test Report

Serial# SL12011902-STR-001_SYNK_Receiver (DFS)
Issue Date Jan 7th, 2013
Page 99 of 109
www.siemic.com

SIEMIC ACCREDITATION DETAILS: Korea CAB ID: US0160



UNITED STATES DEPARTMENT OF COMMERCE
National Institute of Standards and Technology
Gaithersburg, Maryland 20899

December 3, 2012

Mr. Leslie Bai
SIEMIC, Inc.
775 Montague Expressway
Milpitas, CA 95035

Dear Mr. Bai:

NIST is pleased to inform you that your laboratory continues to be recognized by the National Radio Research Agency (RRA) Korea Communications Commission (KCC) under Phase I of the APEC Tel MRA. The scope of recognition has been updated. The information regarding your recognition is as follows:

CAB Name: SIEMIC, Inc.
Physical Location: 775 Montague Expressway, Milpitas, CA 95035
Identification No.: US0160
Updated Scope: **EMI:** RRA Public Notification 2011-24, RRA Announce 2011-30, KN11, KN13, KN14-1, KN 22, KN 41, KN 50, KN 15, KN 19, KN 60, KN 16-1-1, KN 16-1-2, KN 16-1-3, KN 16-1-4, KN 16-1-5, KN 16-2-1, KN 16-2-2, KN 16-2-3, KN 16-2-4, KN 301-489-01, KN 301-489-07, KN 301-489-17, KN 301-489-24, KN 301-489-06, KN 301-489-13, KN 301-489-05, KN 301-489-03, KN 301-489-09, KN 301-489-26, KN 301-489-18, KN 301-489-15, KN 301-489-02, KN 301-489-27, KN 301-489-32, KN 301-489-20, KN 60945;
EMS: RRA Public Notification 2011-25, RRA Announce 2011-31, KN 61000-4-2, KN 61000-4-3, KN 61000-4-4, KN 61000-4-5, KN 61000-4-6, KN 61000-4-8, KN 61000-4-11, KN 60601-1-2, KN 20, KN 14-2, KN 24, KN 41, KN 51, KN 301-489-01, KN 301-489-07, KN 301-489-17, KN 301-489-24, KN 301-489-06, KN 301-489-13, KN 301-489-05, KN 301-489-03, KN 301-489-09, KN 301-489-26, KN 301-489-18, KN 301-489-15, KN 301-489-02, KN 301-489-27, KN 301-489-32, KN 301-489-20, KN 60945;
RF: KCC Public Notification 2012-12, RRA Announce 2011-32, RRA Public Notification 2010-46;
SAR: KCC Public Notification 2009-27, RRA Public Notification 2010-45, KCC Public Notification 2012-2;
TELECOM: RRA Public Notification 2010-36; RRA Public Notification 2009-38, RRA Announce 2011-2 (Annexes 1, 3, 5, 6)

NIST



SIEMIC, INC.

Accessing global markets

Title: RF Test Report of Stryker Endoscopy
Model : P23366
To: FCC DFS Test Report

Serial# SL12011902-STR-001_SYNK_Receiver (DFS)
Issue Date Jan 7th, 2013
Page 100 of 109
www.sieminc.com

You may submit test data to RRA/KCC to verify that the equipment to be imported into Korea satisfies the applicable requirements. The recognition of your organization will remain in force as long as the accreditation for the designated scope remains valid and your organization complies with the designation requirements.

Recognized CABs are listed on the NIST website at <http://gsi.nist.gov/global/index.cfm/L1-4/L2-16/L3-90>. If you have any questions please contact Ramona Saar via email at ramona.saar@nist.gov or phone at (301) 975-5521.

Sincerely,

David F. Alderman
Standards Services Group

Enclosure

cc: Ramona Saar



SIEMIC, Inc.

Accessing global markets

Title: RF Test Report of Stryker Endoscopy
Model : P23366
To: FCC DFS Test Report

Serial# SL12011902-STR-001_SYNK_Receiver (DFS)
Issue Date Jan 7th, 2013
Page 101 of 109
www.sieminc.com

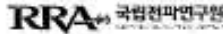

National Radio Research Agency

29, Wonhyuro 41gil, Yongsan-gu, Seoul, 140-848, Korea
Tel: +82 2 710 6600, Fax: +82 2 710 6629
Homepage : www.rra.go.kr

November 27, 2012

Mr. David F. Alderman
Group Leader, Standards Coordination and Conformity Group
National Institute of Standards and Technology
100 Bureau Drive, Stop 2100
Gaithersburg, Maryland 20899-2100, USA

Dear Mr. David F. Alderman:

This is to confirm the recognition by National Radio Research Agency of

SIEMIC, Inc. (US0160)

as an accredited Conformity Assessment Body (CAB) under the terms of Phase I of the APEC TEL MRA.
The scope for which this laboratory has been recognized is given below.

Coverage	Standards	Date of Recognition
Current Scope	BMD : RRA Public Notification 2011-16, RRA Announce 2010-5, KN 11, KN 13, KN14-1, KN 22, KN 41, KN 50, KN 15, KN 19, KN 60, KN 16-1-1, -1-2, -1-3, -1-4, -1-5, -1-1, -1-2, -1-3, -1-4 EMS : RRA Public Notification 2011-17, RRA Announce 2010-6, KN 6100-4-1, -1-5, -1-4, -1-5, -1-6, -1-8, -1-11, KN 6101-1-2, KN 20, KN 24, KN 41, KN 51 RF : KCC Public Notification 2011-31, KCC Public Notification 2011-10, RRA Public Notification 2010-45, KN 301-489-01, -489-07, -489-17, -489-24 SAR : KCC Public Notification 2009-27, RRA Public Notification 2010-45, KCC Public Notification 2011-10 TELECOM : RRA Public Notification 2010-36, RRA Public Notification 2009-38	November 27, 2012
Updated Scope	BMD : RRA Public Notification 2011-24, RRA Announce 2011-30, KN 11, KN 13, KN 14-1, KN 22, KN 41, KN 50, KN 15, KN 19, KN 60, KN 16-1-1, -1-2, -1-3, -1-4, -1-5, -1-1, -1-2, -1-3, -1-4, KN 301-489-01, -489-07, -489-17, -489-24, -489-06, -489-13, -489-05, -489-03, -489-09, -489-26, -489-15, -489-15, -489-02, -489-27, -489-32, -489-20, KN 60945 EMS : RRA Public Notification 2011-25, RRA Announce 2011-31, KN 6100-4-1, -1-3, -1-4, -1-5, -1-6, -1-8, -1-11, KN 6101-1-2, KN 20, KN 14-2, KN 24, KN 41, KN 51, KN 301-489-01, -489-07, -489-17, -489-24, -489-06, -489-13, -489-05, -489-03, -489-09, -489-26, -489-15, -489-15, -489-02, -489-27, -489-32, -489-20, KN 60945 RF : KCC Public Notification 2012-12, RRA Announce 2011-32, RRA Public Notification 2010-45 SAR : KCC Public Notification 2009-27, RRA Public Notification 2010-45, KCC Public Notification 2012-2 TELECOM : RRA Public Notification 2010-36, RRA Public Notification 2009-38, RRA Announce 2011-02(Annexes 1, 3, 5, 6)	

This recognition is contingent upon the maintenance of this CAB's accreditation status and is limited to the standards listed above.

If you have any inquiries about this recognition, please contact to Conformity Policy Division of National Radio Research Agency with above address and telephone numbers.

Best Regards,

Yoon, Hye-joon
Director

Conformity Policy Division

cc: Ramona Saar - NIST
Gerry Funk - NIST



SIEMIC, Inc.

Accessing global markets

Title: RF Test Report of Stryker Endoscopy
Model : P23366
To: FCC DFS Test Report

Serial# SL12011902-STR-001_SYNK_Receiver (DFS)
Issue Date Jan 7th, 2013
Page 102 of 109
www.sieminc.com

SIEMIC ACCREDITATION DETAILS: Taiwan BSMI Accreditation No. SL2-IN-E-1130R



UNITED STATES DEPARTMENT OF COMMERCE
National Institute of Standards and Technology
Gaithersburg, Maryland 20899

May 3, 2006

Mr. Leslie Bai
SIEMIC Laboratories
2206 Ringwood Avenue
San Jose, CA 95131

Dear Mr. Bai:

I am pleased to inform you that your laboratory has been recognized by the Chinese Taipei's Bureau of Standards, Metrology, and Inspection (BSMI) under the Asia Pacific Economic Cooperation (APEC) Mutual Recognition Arrangement (MRA). Your laboratory is now designated to act as a Conformity Assessment Body (CAB) under Appendix B, **Phase I** Procedures, of the APEC Tel MRA. You may submit test data to BSMI to verify that the equipment to be imported into Chinese Taipei satisfies the applicable requirements. The designation of your organization will remain in force as long as its accreditation for the designated scope remains valid and comply with the designation requirements. The pertinent designation information is as follows:

- BSMI number: **SL2-IN-E-1130R** (Must be applied to the test reports)
- U.S. Identification No: **US0160**
- Scope of Designation: **CNS 13438**
- Authorized signatory: **Mr. Leslie Bai**

The names of all recognized CABs will be posted on the NIST website at <http://ts.nist.gov/mra>. If you have any questions, please contact Mr. Dhillon at 301-975-5521. We appreciate your continued interest in our international conformity assessment activities.

Sincerely,

David F. Alderman
Group Leader, Standards Coordination and Conformity Group

cc: Jogindar Dhillon

NIST



SIEMIC, Inc.

Accessing global markets

Title: RF Test Report of Stryker Endoscopy
Model : P23366
To: FCC DFS Test Report

Serial# SL12011902-STR-001_SYNK_Receiver (DFS)
Issue Date Jan 7th, 2013
Page 103 of 109
www.siemec.com

SIEMIC ACCREDITATION DETAILS: Taiwan NCC CAB ID: US0160



UNITED STATES DEPARTMENT OF COMMERCE
National Institute of Standards and Technology
Gaithersburg, Maryland 20899

April 25, 2011

Mr. Leslie Bai
SIEMIC, Inc.
2206 Ringwood Avenue
San Jose, CA 95131

Dear Mr. Bai:

NIST is pleased to inform you that your laboratory has been recognized by the National Communications Commission (NCC) under the Asia Pacific Economic Cooperation for Telecommunications Equipment Mutual Recognition Arrangement (APEC Tel MRA). Your laboratory is now designated to act as a Conformity Assessment Body (CAB) under Appendix B, **Phase I** Procedures, of the APEC Tel MRA. The pertinent information about the laboratory's designation is as follows:

CAB Name: SIEMIC, Inc.
Physical Location: 2206 Ringwood Avenue, San Jose, CA 95131
Identification No.: US0160
Previous Scope: LP0002, PSTN01, ADSL01, ID0002, IS6100, CNS 14336, PLMN07
Current Scope: LP0002, PSTN01, ADSL01, ID0002, IS6100, CNS 14336, PLMN07, PLMN01 and PLMN08

You may submit test data to NCC to verify that the equipment to be imported into Chinese Taipei satisfies the applicable requirements. The designation of your organization will remain in force as long as its accreditation for the designated scope remains valid and comply with the designation requirements.

Recognized CABs are listed on the NIST website at <http://ts.nist.gov/mra>. If you have any questions please contact Ramona Saar at (301) 975-5521 or ramona.saar@nist.gov.

Sincerely,

David F. Alderman
Standards Services Group

Enclosure

cc: Ramona Saar

NIST



SIEMIC, Inc.

Accessing global markets

Title: RF Test Report of Stryker Endoscopy
Model : P23366
To: FCC DFS Test Report

Serial# SL12011902-STR-001_SYNK_Receiver (DFS)
Issue Date Jan 7th, 2013
Page 104 of 109
www.sieminc.com

SIEMIC ACCREDITATION DETAILS: Vietnam CAB ID: US0160



UNITED STATES DEPARTMENT OF COMMERCE
National Institute of Standards and Technology
Gaithersburg, Maryland 20899

July 11, 2012

Mr. Leslie Bai
SIEMIC, Inc.
2206 Ringwood Avenue
San Jose, CA 95131

Dear Mr. Bai:

NIST is pleased to inform you that your laboratory continues to be recognized by Vietnam's Ministry of Information and Communication (MIC) under the Asia Pacific Economic Cooperation for Telecommunications Equipment Mutual Recognition Arrangement (APEC Tel MRA). MIC has updated your scope of recognition. The pertinent information about the continued recognition is as follows:

CAB Name:	SIEMIC, Inc.
Physical Location:	2206 Ringwood Avenue, San Jose, CA 95131
Identification No.:	US0160
Current Scope:	TCN68-188, TCN68-190, TCN68-193, TCN68-196, TCN68-143, TCN68-192, TCN68-189, TCN68-221, TCN68-222, TCN68-223, TCN68-245, TCN68-242, TCN68-243, TCN68-246, TCVN 7189
Updated Scope:	QCVN 19:2010/BTTTT, QCVN 22:2010/BTTTT, TCVN 7189:2009, TCVN 7317:2003, QCVN 10:2010/BTTTT, QCVN 12:2010/BTTTT, QCVN 3:2010/BTTTT QCVN 15:2010/BTTTT, QCVN 11:2010/BTTTT, QCVN 54:2011/BTTTT, QCVN 55:2011/BTTTT, QCVN 18:2010/BTTTT, QCVN 17:2010/BTTTT

You may submit test data to MIC to verify that the equipment to be imported into Vietnam satisfies the applicable requirements. *Please note that your recognition from Vietnam will expire on **September 30, 2012**. To continue the recognition beyond this date, it will be necessary to submit to NIST the updated ISO/IEC 17025 Scope and Certification of Accreditation as soon as it is reissued during your next accreditation renewal period. NIST will then submit the updated information to MIC so that the recognition can be extended.*

Recognized CABs are listed on the NIST website at <http://gsi.nist.gov/global/index.cfm?l=1-4/l.2-16/l.3-90/A-380>. If you have any questions please contact Ramona Saar via email at ramona_saar@nist.gov or phone at (301) 975-5521.

Sincerely,

David F. Alderman
Standards Services Group

Enclosure

cc: Ramona Saar



SIEMIC, Inc.

Accessing global markets

Title: RF Test Report of Stryker Endoscopy
Model : P23366
To: FCC DFS Test Report

Serial# SL12011902-STR-001_SYNK_Receiver (DFS)
Issue Date Jan 7th, 2013
Page 105 of 109
www.sieminc.com

SIEMIC ACCREDITATION DETAILS: Mexico NOM Recognition



CAMARA NACIONAL
DE LA INDUSTRIA
ELECTRONICA, DE
TELECOMUNICACIONES
E INFORMÁTICA

Laboratorio Valentín V. Rivero

México D.F. a 16 de octubre de 2006.

**LESLIE BAI
DIRECTOR OF CERTIFICATION
SIEMIC LABORATORIES, INC.
ACCESSING GLOBAL MARKETS
P R E S E N T E**

En contestación a su escrito de fecha 5 de septiembre del año en curso, le comento que estamos muy interesados en su intención de firmar un Acuerdo de Reconocimiento Mutuo, para lo cual adjunto a este escrito encontrara el Acuerdo en idioma ingles y español preferido de los cuales le pido sea revisado y en su caso corregido, para que si este de acuerdo poder firmarlo para mandarlo con las autoridades Mexicanas para su visto bueno y así poder ejercer dicho acuerdo.

Aprovecho este escrito para mencionarle que nuestro intermediario gestor será la empresa Isatel de México S. A. de C. V., empresa que ha colaborado durante mucho tiempo con nosotros en lo relacionado a la evaluación de la conformidad y que cuenta con amplia experiencia en la gestión de la certificación de cumplimiento con Normas Oficiales Mexicanas de producto en México.

Me despido de usted enviándole un cordial saludo y esperando sus comentarios al Acuerdo que nos ocupa.

Atentamente:

**Ing. Faustino Gomez González
Gerente Técnico del Laboratorio de
CANIETI**

Calle 21
Hidrovia Condés
06100 México, D.F.
Tel: 5206 6808 con 12 líneas
Fax: 5206 6492
www.canieti.org

SIEMIC ACCREDITATION DETAILS: Hong Kong OFTA CAB ID : US0160



UNITED STATES DEPARTMENT OF COMMERCE
National Institute of Standards and Technology
Gaithersburg, Maryland 20899

December 8, 2008

Mr. Leslie Bai
SIEMIC, Inc.
2206 Ringwood Avenue
San Jose, CA 95131

Dear Mr. Bai:

NIST is pleased to inform you that your laboratory has been recognized by the Office of the Telecommunications Authority (OFTA) under the Asia Pacific Economic Cooperation for Telecommunications Equipment Mutual Recognition Arrangement (APEC Tel MRA). Your laboratory is now designated to act as a Conformity Assessment Body (CAB) under Appendix B, **Phase I** Procedures, of the APEC Tel MRA. The pertinent information about your laboratory's designation is as follows:

CAB Name: SIEMIC, Inc.
Physical Location: 2206 Ringwood Avenue, San Jose, California 95131 USA
Identification No.: US0160
Recognized Scope: **Radio:** HKTA 1002, 1007, 1008, 1010, 1015, 1016, 1020, 1022, 1026, 1027, 1029, 1030, 1031, 1032, 1033, 1034, 1035, 1036, 1037, 1039, 1041, 1042, 1043, 1044, 1046, 1047, 1048, 1049, 1051
Telecom: HKTA 2011, 2012, 2013, 2014, 2017, 2018, 2022, 2024, 2026, 2027, 2028, 2029, 2030, 2031, 2032, 2033

You may submit test data to OFTA to verify that the equipment to be imported into Hong Kong satisfies the applicable requirements. The designation of your organization will remain in force as long as its accreditation for the designated scope remains valid and comply with the designation requirements.

Recognized CABs are listed on the NIST website at <http://ts.nist.gov/mra>. If you have any questions please contact Ramona Saar at (301) 975-5521 or ramona.saar@nist.gov.

Sincerely,

David F. Alderman
Group Leader, Standards Coordination and Conformity Group
Standards Services Division

Enclosure

cc: Ramona Saar



SIEMIC ACCREDITATION DETAILS: Australia ACMA CAB ID: US0160



UNITED STATES DEPARTMENT OF COMMERCE
National Institute of Standards and Technology
Gaithersburg, Maryland 20899-

November 20, 2008

Mr. Leslie Bai
SIEMIC, Inc.
2206 Ringwood Avenue
San Jose, CA 95131

Dear Mr. Bai:

NIST is pleased to inform you that your laboratory has been recognized by the Australian Communications and Media Authority (ACMA) under the Asia Pacific Economic Cooperation for Telecommunications Equipment Mutual Recognition Arrangement (APEC Tel MRA). Your laboratory is now designated to act as a Conformity Assessment Body (CAB) under Appendix B, **Phase I** Procedures, of the APEC Tel MRA. The pertinent information about your laboratory's designation is as follows:

- CAB Name: Siemic, Inc.
- Physical Location: 2206 Ringwood Avenue, San Jose, CA 95131
- Identification No.: US0160
- Recognized Scope: EMC: AS/NZS 4251.1 (until 5/31/2009), AS/NZS 4251.2 (until 5/31/2009), AS/NZS CISPR 11, AS/NZS CISPR 14.1, AS/NZS CISPR 22, AS/NZS 61000.6.3, AS/NZS 61000.6.4
Radiocommunications: AS/NZS 4281, AS/NZS 4268, AS/NZS 4280.1, AS/NZS 4280.2, AS/NZS 4295, AS/NZS 4582, AS/NZS 4583, AS/NZS 4769.1, AS/NZS 4769.2, AS/NZS 4770, AS/NZS 4771
Telecommunications: AS/ACIF S002:05, AS/ACIF S003:06, AS/ACIF S004:06, AS/ACIF S006:01, AS/ACIF S016:01, AS/ACIF S031:01, AS/ACIF S038:01, AS/ACIF S040:01, AS/ACIF S041:05, AS/ACIF S043.2:06, AS/NZS 60950.1

You may submit test data to ACMA to verify that the equipment to be imported into Australia satisfies the applicable requirements. The designation of your organization will remain in force as long as its accreditation for the designated scope remains valid and comply with the designation requirements. Recognized CABs are listed on the NIST website at <http://ts.nist.gov/mra>. Please contact Ms. Ramona Saar, at (301) 975-5521 or ramona.saar@nist.gov if you have questions.

Sincerely,

David F. Alderman
Group Leader, Standards Coordination and Conformity Group
Standards Services Division

Enclosure

cc: Snell Leong, Siemic, Inc.; Ramona Saar, NIST



SIEMIC ACCREDITATION DETAILS: Australia NATA Recognition



Leslie Bai
SIEMIC, Inc.
2206 Ringwood Avenue
San Jose, CA 95131

November 4, 2008

Under Australian government legislation, the Australian Communications and Media Authority (ACMA) has determined the National Association of Testing Authorities, Australia (NATA) as an accreditation body as per Section 409(1) of the Telecommunications Act 1997 (Cth). Pursuant to Section 409(2) of the Telecommunications Act 1997 (Cth), I am pleased to advise that your laboratory has been determined as a Recognised Testing Authority (RTA).

This determination has been made on the basis of your accreditation by A2LA accreditation no. 2742.01 and the Mutual Recognition Agreement between NATA and A2LA. It is effective from 11 July 2008. RTA status applies only to the following standards and is contingent upon their continued inclusion in your laboratory's scope of accreditation.

**AS/ACIF S002, AS/ACIF S003, AS/ACIF S004,
AS/ACIF S006, AS/ACIF S016, AS/ACIF S031,
AS/ACIF S038, AS/ACIF S041 and
AS/ACIF S043.2**

As an RTA, your laboratory has the following obligations:

1. the laboratory shall continue to meet all of the accreditation criteria of A2LA;
2. the authorised representative of the laboratory shall notify NATA of changes to the staff or operations of the laboratory which would affect the performance of the tests for which the laboratory has been determined;
3. compliance of equipment shall be reported on test reports bearing the A2LA logo/endorsement.

Current information on the Australian Communications and Media Authority and regulatory requirements for telecommunications products within Australia can be obtained from the ACMA's web-site at "<http://www.acma.gov.au>". Further information about NATA may be gained by visiting "<http://www.nata.asn.au>".

Please note that AS/ACIF S040 and New Zealand standards do not form part of the RTA scheme.

Your RTA listing will appear on the NATA website shortly.

Kind Regards

Chris Norton,
Senior Scientific Officer
Measurement Science and Technology
National Association of Testing Authorities (NATA)
71-73 Flemington Road
North Melbourne Vic 3051
Australia
Ph: +61 3 9329 1633 Fx: +61 3 9326 5148
E-Mail: Christopher.Norton@nata.asn.au
Internet: www.nata.asn.au

SIEMIC ACCREDITATION DETAILS: VCCI Radiated Test Site Registration No. A-0133

Certificate of VCCI Laboratory registration

1. Registration Information																									
1.1 Laboratory Info.	<table border="1" style="width: 100%; border-collapse: collapse;"> <tr> <td style="width: 35%;">Company name (VCCI Membership No.)</td> <td>SIEMIC Laboratories (3081)</td> </tr> <tr> <td>Laboratory Name</td> <td>SIEMIC Labs (Milpitas location)</td> </tr> <tr> <td>VCCI Laboratory registration No.</td> <td>A-0133</td> </tr> <tr> <td>VCCI Laboratory registration date</td> <td>09/21/2012 (mm/dd/yyyy)</td> </tr> <tr> <td>Registration expiration date</td> <td>09/30/2014 (mm/dd/yyyy)</td> </tr> <tr> <td>Country of Laboratory</td> <td>USA</td> </tr> <tr> <td>ISO 17025 Accreditation body name</td> <td>A2LA</td> </tr> <tr> <td>Accreditation No.</td> <td>2742.01</td> </tr> <tr> <td>Accreditation valid to mm/dd/yyyy</td> <td>09/30/2014 (mm/dd/yyyy)</td> </tr> <tr> <td>Edition (year) of the VCCI rule indicated in the scope of accreditation (example: V-3 20xx.04)</td> <td>Not described in Scope</td> </tr> <tr> <td>Zip code</td> <td>95035</td> </tr> <tr> <td>Address</td> <td>775 Montague Expressway, Milpitas , CA 95035 USA</td> </tr> </table>	Company name (VCCI Membership No.)	SIEMIC Laboratories (3081)	Laboratory Name	SIEMIC Labs (Milpitas location)	VCCI Laboratory registration No.	A-0133	VCCI Laboratory registration date	09/21/2012 (mm/dd/yyyy)	Registration expiration date	09/30/2014 (mm/dd/yyyy)	Country of Laboratory	USA	ISO 17025 Accreditation body name	A2LA	Accreditation No.	2742.01	Accreditation valid to mm/dd/yyyy	09/30/2014 (mm/dd/yyyy)	Edition (year) of the VCCI rule indicated in the scope of accreditation (example: V-3 20xx.04)	Not described in Scope	Zip code	95035	Address	775 Montague Expressway, Milpitas , CA 95035 USA
Company name (VCCI Membership No.)	SIEMIC Laboratories (3081)																								
Laboratory Name	SIEMIC Labs (Milpitas location)																								
VCCI Laboratory registration No.	A-0133																								
VCCI Laboratory registration date	09/21/2012 (mm/dd/yyyy)																								
Registration expiration date	09/30/2014 (mm/dd/yyyy)																								
Country of Laboratory	USA																								
ISO 17025 Accreditation body name	A2LA																								
Accreditation No.	2742.01																								
Accreditation valid to mm/dd/yyyy	09/30/2014 (mm/dd/yyyy)																								
Edition (year) of the VCCI rule indicated in the scope of accreditation (example: V-3 20xx.04)	Not described in Scope																								
Zip code	95035																								
Address	775 Montague Expressway, Milpitas , CA 95035 USA																								

