



# TEST REPORT

Report Reference No..... : **TRE1709024406** R/C.....: 88964

FCC ID..... : **SS4RT080**

Applicant's name..... : **BLUEBIRD INC.**

Address..... : (Dogok-dong, SEI Tower 13,14) 39, Eonjuro30-gil, Gangnam-gu, Seoul, South Korea

Manufacturer..... : BLUEBIRD INC.

Address..... : (Dogok-dong, SEI Tower 13,14) 39, Eonjuro30-gil, Gangnam-gu, Seoul, South Korea

Test item description ..... : **Smart Rugged Tablet Computer**

Trade Mark ..... : BLUEBIRD

Model/Type reference..... : RT080

Listed Model(s) ..... : -

Standard ..... : **FCC CFR Title 47 Part 15 Subpart C Section 15.225**

Date of receipt of test sample..... : Sep.28, 2017

Date of testing..... : Sep.29, 2017 - Oct.18, 2017

Date of issue..... : Oct.19, 2017

Result..... : **PASS**

Compiled by  
( position+printedname+signature)....: File administrators Candy Liu

Supervised by  
(position+printedname+signature).....: Project Engineer Edward Pan

Approved by  
(position+printedname+signature).....: RF Manager Hans Hu

Testing Laboratory Name ..... : **Shenzhen Huatongwei International Inspection Co., Ltd.**

Address..... : 1/F, Bldg 3, Hongfa Hi-tech Industrial Park, Genyu Road, Tianliao, Gongming, Shenzhen, China

**Shenzhen Huatongwei International Inspection Co., Ltd. All rights reserved.**

This publication may be reproduced in whole or in part for non-commercial purposes as long as the Shenzhen Huatongwei International Inspection Co., Ltd. is acknowledged as copyright owner and source of the material. Shenzhen Huatongwei International Inspection Co., Ltd. takes no responsibility for and will not assume liability for damages resulting from the reader's interpretation of the reproduced material due to its placement and context.

## Contents

<b>1.</b>	<b><u>TEST STANDARDS AND TEST DESCRIPTION</u></b>	<b>3</b>
1.1.	Test Standards	3
1.2.	Report version	3
<b>2.</b>	<b><u>TEST DESCRIPTION</u></b>	<b>4</b>
<b>3.</b>	<b><u>SUMMARY</u></b>	<b>5</b>
3.1.	Client Information	5
3.2.	Product Description	5
3.3.	EUT operation mode	5
3.4.	EUT configuration	5
3.5.	Modifications	6
<b>4.</b>	<b><u>TEST ENVIRONMENT</u></b>	<b>6</b>
4.1.	Address of the test laboratory	6
4.2.	Test Facility	6
4.3.	Environmental conditions	7
4.4.	Statement of the measurement uncertainty	7
4.5.	Equipments Used during the Test	8
<b>5.</b>	<b><u>CONDUCTED EMISSIONS</u></b>	<b>8</b>
<b>6.</b>	<b><u>TEST CONDITIONS AND RESULTS</u></b>	<b>9</b>
6.1.	Antenna requirement	9
6.2.	AC Power Conducted Emissions	10
6.3.	Field Strength of Fundamental Emission and Mask Measurement	13
6.4.	20 dB Occupied Bandwidth	15
6.5.	Radiated Emissions	16
6.6.	Frequency Stability Measurement	19
<b>7.</b>	<b><u>TEST SETUP PHOTOS OF THE EUT</u></b>	<b>21</b>
<b>8.</b>	<b><u>EXTERNAL AND INTERNAL PHOTOS OF THE EUT</u></b>	<b>21</b>

## 1. TEST STANDARDS AND TEST DESCRIPTION

### 1.1. Test Standards

The tests were performed according to following standards:

[FCC Rules Part 15.225](#): Operation within the band 13.110-14.010 MHz

[ANSI C63.10-2013](#): American National Standard for Testing Unlicensed Wireless Devices.

### 1.2. Report version

Version No.	Date of issue	Description
00	Oct.19, 2017	Original

## **2. Test Description**

Test Item	Section in CFR 47	Result
Antenna requirement	15.203	Pass
AC Power Line Conducted Emissions	15.207	Pass
Field Strength of Fundamental Emissions and Mask Measurement	15.225	Pass
20dB Occupied Bandwidth	15.215&15.215	Pass
Radiated Emission	15.209	Pass
Frequency Stability Measurement	15.225	Pass

Remark: The measurement uncertainty is not included in the test result.

### 3. SUMMARY

#### 3.1. Client Information

Applicant:	BLUEBIRD INC.
Address:	(Dogok-dong, SEI Tower 13,14) 39, Eonjuro30-gil, Gangnam-gu, Seoul, South Korea
Manufacturer:	BLUEBIRD INC.
Address:	(Dogok-dong, SEI Tower 13,14) 39, Eonjuro30-gil, Gangnam-gu, Seoul, South Korea

#### 3.2. Product Description

Name of EUT:	Smart Rugged Tablet Computer
Trade Mark:	BLUEBIRD
Model No.:	RT080
Listed Model(s):	-
IMEI:	865006020017332
Power supply:	DC 3.8V From exchange battery
Adapter information:	Input: 100-240Va.c., 50/60Hz, 0.5A Output: 5Vd.c.,2.0A
Hardware version:	V0.3
Software version:	20171011_R1.02
<b>NFC</b>	
Operation frequency:	13.56MHz
Channel number:	1
Modulation Type:	ASK
Antenna type:	Integral antenna
Antenna gain:	1dBi

#### 3.3. EUT operation mode

For RF test items
The engineering test program was provided and enabled to make EUT continuous transmit.
For AC power line conducted emissions:
The EUT was set to connect with large package sizes transmission.

#### 3.4. EUT configuration

The following peripheral devices and interface cables were connected during the measurement:

- - supplied by the manufacturer
- - supplied by the lab

	Manufacturer :	/
	Model No. :	/
	Manufacturer :	/
	Model No. :	/

### 3.5. Modifications

No modifications were implemented to meet testing criteria.

## 4. TEST ENVIRONMENT

### 4.1. Address of the test laboratory

Laboratory: Shenzhen Huatongwei International Inspection Co., Ltd.

Address: 1/F, Bldg 3, Hongfa Hi-tech Industrial Park, Genyu Road, Tianliao, Gongming, Shenzhen, China

Phone: 86-755-26748019 Fax: 86-755-26748089

### 4.2. Test Facility

The test facility is recognized, certified, or accredited by the following organizations:

#### **CNAS-Lab Code: L1225**

Shenzhen Huatongwei International Inspection Co., Ltd. has been assessed and proved to be in compliance with CNAS-CL01 Accreditation Criteria for Testing and Calibration Laboratories (identical to ISO/IEC 17025: 2005 General Requirements) for the Competence of Testing and Calibration Laboratories.

#### **A2LA-Lab Cert. No. 3902.01**

Shenzhen Huatongwei International Inspection Co., Ltd. EMC Laboratory has been accredited by A2LA for technical competence in the field of electrical testing, and proved to be in compliance with ISO/IEC 17025: 2005 General Requirements for the Competence of Testing and Calibration Laboratories and any additional program requirements in the identified field of testing.

#### **FCC-Registration No.: 762235**

Shenzhen Huatongwei International Inspection Co., Ltd. EMC Laboratory has been registered and fully described in a report filed with the FCC (Federal Communications Commission). The acceptance letter from the FCC is maintained in our files.

#### **IC-Registration No.: 5377B-1**

Two 3m Alternate Test Site of Shenzhen Huatongwei International Inspection Co., Ltd. has been registered by Certification and Engineering Bureau of Industry Canada for the performance of radiated measurements with Registration No. 5377B-1.

#### **ACA**

Shenzhen Huatongwei International Inspection Co., Ltd. EMC Laboratory can also perform testing for the Australian C-Tick mark as a result of our A2LA accreditation.

### 4.3. Environmental conditions

During the measurement the environmental conditions were within the listed ranges:

Temperature:	15~35°C
Relative Humidity:	30~60 %
Air Pressure:	950~1050mba

### 4.4. Statement of the measurement uncertainty

The data and results referenced in this document are true and accurate. The reader is cautioned that there may be errors in calibration limits of the equipment and facilities. The measurement uncertainty was calculated for all measurements listed in this test report according to TR-100028-01 "Electromagnetic compatibility and Radio spectrum Matters (ERM);Uncertainties in the measurement of mobile radio equipment characteristics;Part 1" and TR-100028-02 "Electromagnetic compatibility and Radio spectrum Matters (ERM);Uncertainties in the measurement of mobile radio equipment characteristics;Part 2" and is documented in the Shenzhen Huatongwei International Inspection Co., Ltd quality system according to ISO/IEC 17025. Further more, component and process variability of devices similar to that tested may result in additional deviation. The manufacturer has the sole responsibility of continued compliance of the device.

Here after the best measurement capability for Shenzhen Huatongwei is reported:

Test Items	Measurement Uncertainty	Notes
Conducted spurious emissions 9KHz-30MHz	3.39 dB	(1)
Radiated Emissions 30~1000MHz	4.24 dB	(1)
Radiated Emissions 1~18GHz	5.16 dB	(1)
Radiated Emissions 18-40GHz	5.54 dB	(1)
Occupied Bandwidth	-----	(1)

(1) This uncertainty represents an expanded uncertainty expressed at approximately the 95% confidence level using a coverage factor of  $k=1.96$ .

## 4.5. Equipments Used during the Test

**5. Conducted Emissions**

Item	Test Equipment	Manufacturer	Model No.	Serial No.	Last Cal.
1	Artificial Mains	Rohde&Schwarz	ESH2-Z5	100028	2016/11/13
2	EMI Test Receiver	Rohde&Schwarz	ESCI3	100038	2016/11/13
3	Pulse Limiter	Rohde&Schwarz	ESHSZ2	100044	2016/11/13
4	EMI Test Software	Rohde&Schwarz	ES-K1 V1.71	-	-

## Radiated Emissions

Item	Test Equipment	Manufacturer	Model No.	Serial No.	Last Cal.
1	EMI test receiver	Rohde&Schwarz	ESI 26	100009	2016/11/13
2	Loop Antenna	Rohde&Schwarz	HFH2-Z2	100020	2016/11/13
3	Ultra-Broadband Antenna	ShwarzBeck	VULB9163	538	2016/11/13
4	Horn antenna	ShwarzBeck	9120D	1011	2016/11/13
5	Horn Antenna	SCHWARZBECK	BBHA9170	25841	2016/11/13
6	Amplifier	Sonoma	310N	E009-13	2016/11/13
7	JS Amplifier	Rohde&Schwarz	JS4-00101800-28-5A	F201504	2016/11/13
8	Amplifier	Compliance Direction systems	PAP1-4060	120	2016/11/13
9	High pass filter	Compliance Direction systems	BSU-6	34202	2016/11/13
10	EMI test Software	Rohde&Schwarz	ESK1	-	-
11	EMI test Software	Audix	E3	-	-
12	TURNTABLE	MATURO	TT2.0	-	-
13	ANTENNA MAST	MATURO	TAM-4.0-P	-	-

## RF Conducted methods

Item	Test Equipment	Manufacturer	Model No.	Serial No.	Last Cal.
1	Spectrum Analyzer	Rohde&Schwarz	FSP	1164.4391.40	2016/11/13
2	MXA Signal Analyzer	Agilent Technologies	N9020A	MY5050187	2016/11/13

The Cal.Interval was one year.



## 6. TEST CONDITIONS AND RESULTS

### 6.1. Antenna requirement

#### Requirement

##### **FCC CFR Title 47 Part 15 Subpart C Section 15.203:**

An intentional radiator shall be designed to ensure that no antenna other than that furnished by the responsible party shall be used with the device. The use of a permanently attached antenna or of an antenna that uses a unique coupling to the intentional radiator, the manufacturer may design the unit so that a broken antenna can be replaced by the user, but the use of a standard antenna jack or electrical connector is prohibited.

#### **Refer to statement below for compliance.**

The manufacturer may design the unit so that the user can replace a broken antenna, but the use of a standard antenna jack or electrical connector is prohibited. Further, this requirement does not apply to intentional radiators that must be professionally installed.

#### **Test Result:**

The directional gain of the antenna less than 6 dBi, please refer to the below antenna photo.



## 6.2. AC Power Conducted Emissions

### LIMIT

FCC CFR Title 47 Part 15 Subpart C Section 15.207:

Frequency range (MHz)	Limit (dBuV)	
	Quasi-peak	Average
0.15-0.5	66 to 56*	56 to 46*
0.5-5	56	46
5-30	60	50

\* Decreases with the logarithm of the frequency.

### TEST CONFIGURATION

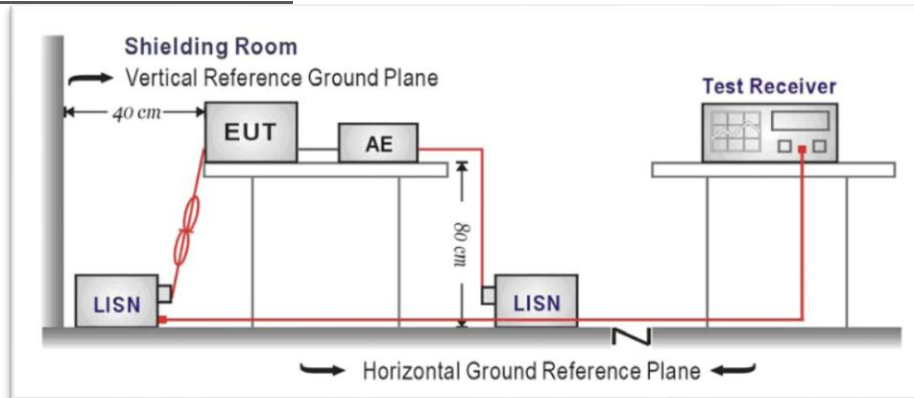

### TEST PROCEDURE

1. The EUT was setup according to ANSI C63.10:2013 for compliance to FCC 47CFR 15.247 requirements.
2. The EUT was placed on a plat form of nominal size, 1 m by 1.5 m, raised 10 cm above the conducting ground plane. The vertical conducting plane was located 40 cm to the rear of the EUT. All other surfaces of EUT were at least 10 cm from any other grounded conducting surface.
3. The EUT and simulators are connected to the main power through a line impedance stabilization network (LISN). The LISN provides a 50ohm / 50uH coupling impedance for the measuring equipment.
4. The peripheral devices are also connected to the main power through a LISN. (Please refer to the block diagram of the test setup and photographs)
5. Each current-carrying conductor of the EUT power cord, except the ground (safety) conductor, was individually connected through a LISN to the input power source.
6. The excess length of the power cord between the EUT and the LISN receptacle were folded back and forth at the center of the lead to form a bundle not exceeding 40 cm in length.
7. Conducted emissions were investigated over the frequency range from 0.15MHz to 30MHz using a receiver bandwidth of 9 kHz.
8. During the above scans, the emissions were maximized by cable manipulation.

**TEST RESULTS**

Test Line: L

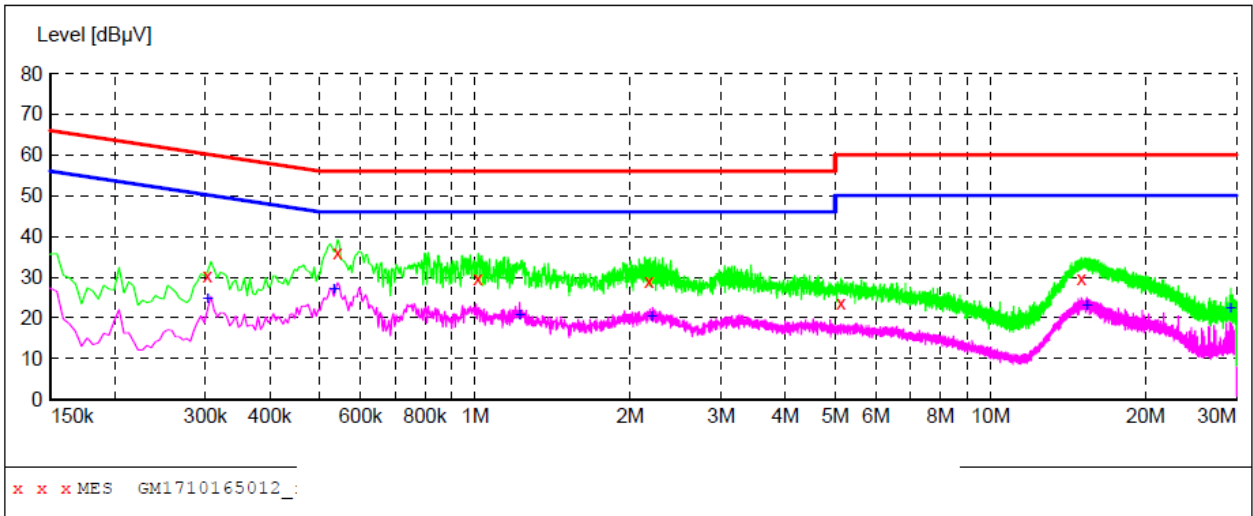

Frequency MHz	Level dBµV	Transd dB	Limit dBµV	Margin dB	Detector	Line	PE
0.303000	30.40	10.2	60	29.8	QP	L1	GND
0.541500	35.90	10.2	56	20.1	QP	L1	GND
1.014000	29.80	10.2	56	26.2	QP	L1	GND
2.175000	28.90	10.2	56	27.1	QP	L1	GND
5.127000	23.60	10.3	60	36.4	QP	L1	GND
15.031500	29.70	10.5	60	30.3	QP	L1	GND

Frequency MHz	Level dBµV	Transd dB	Limit dBµV	Margin dB	Detector	Line	PE
0.303000	24.50	10.2	50	25.7	AV	L1	GND
0.532500	27.10	10.2	46	18.9	AV	L1	GND
1.221000	20.70	10.2	46	25.3	AV	L1	GND
2.202000	20.40	10.2	46	25.6	AV	L1	GND
15.373500	23.00	10.5	50	27.0	AV	L1	GND
29.233500	22.30	10.8	50	27.7	AV	L1	GND

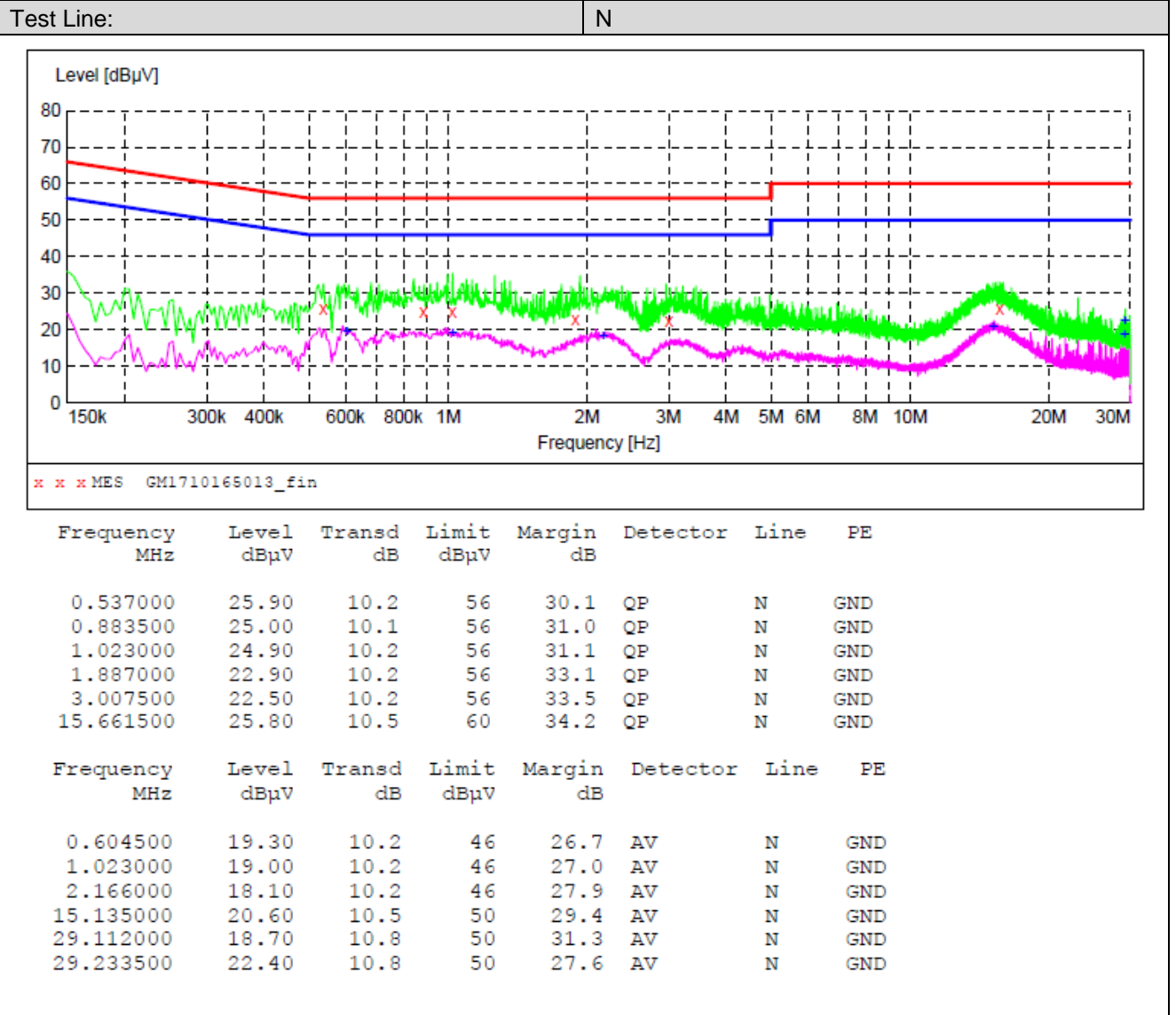

### 6.3. Field Strength of Fundamental Emission and Mask Measurement

#### Limit

Operation frequency range 13.11MHz~14.01MHz.

Frequency (MHz)	Field Strength (microvolts/meter) at 30m	Field Strength (dBuV/m) at 3m
1.705~13.110	30	69.5
13.110~13.410	106	80.5
13.410~13.553	334	90.5
13.553~13.567	15848	124.0
13.567~13.710	334	90.5
13.710~14.010	106	80.5
14.010~30.000	30	69.5

#### TEST CONFIGURATION

Radiated Emission Test Set-Up  
Frequency range 9KHz–30MHz

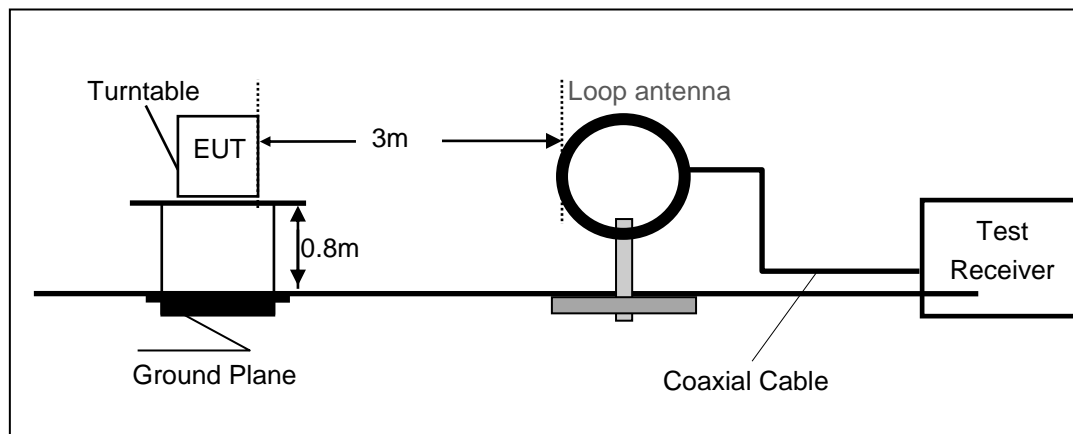

#### TEST PROCEDURE

1. The EUT was tested according to ANSI C63.10:2013 for compliance to FCC 47CFR 15.225 requirements.
2. The EUT is placed on a turn table which is 0.8 meter above ground plane. The turn table is rotated 360 degrees to determine the position of the maximum emission level.
3. The EUT was positioned such that the distance from antenna to the EUT was 3 meters.
4. The antenna is scanned from 1 meter to 4 meters to find out the maximum emission level. This is repeated for both horizontal and vertical polarization of the antenna.
5. Use the following spectrum analyzer settings
6. Span shall wide enough to fully capture the emission being measured;
  - (1) Span shall wide enough to fully capture the emission being measured;
  - (2) From 13.11MHz to 14.01MHz, RBW=10KHz, VBW=30KHz, Sweep=auto, Detector function=peak,
  - (3) Below 1GHz, RBW=120KHz, VBW=300KHz, Sweep=auto, Detector function=peak, Trace=max hold; If the emission level of the EUT measured by the peak detector is 3 dB lower than the applicable limit, the peak emission level will be reported. Otherwise, the emission measurement will be repeated using the quasi-peak detector and reported.

#### TEST RESULTS

Frequency MHz	Mea.Frequency MHz	Test result (dB $\mu$ V/m@3m)	Limit (dBuV/m @3m)	Margin dB	Det.	Result
13.110~13.410	13.400	24.36	80.50	-56.14	Quasi	Pass
13.410~13.553	13.551	23.45	90.5	-67.05	Quasi	Pass
13.553~13.567	13.560	56.86	124.00	-67.14	Quasi	Pass
13.567~13.710	13.568	23.37	90.50	-67.13	Quasi	Pass
13.710~14.010	13.710	23.76	85.50	-61.74	Quasi	Pass

### 6.4. 20 dB Occupied Bandwidth

**Limit**

Operation frequency range 13.11MHz~14.01MHz.

**TEST CONFIGURATION**

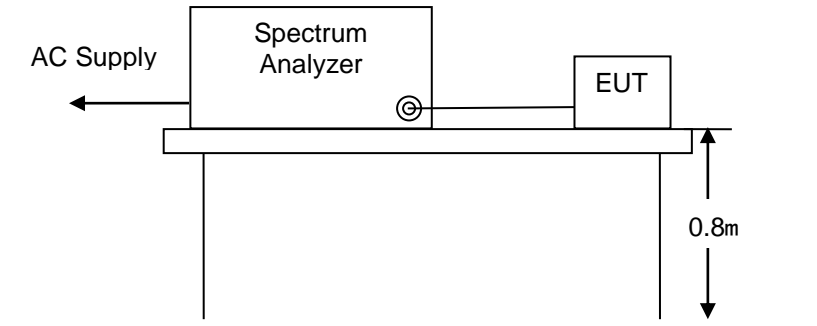

**TEST PROCEDURE**

- 1.As required by 47 CFR 15.215 and 47 CFR 15.225
2. The EUT connected to the spectrum analyzer was operated in linear scale and 2.0MHz span mode after tuning to the transmitter frequency.

**TEST RESULTS**

Frequency(MHz)	20dB Bandwidth(KHz)	Result
13.56	541.24	PASS

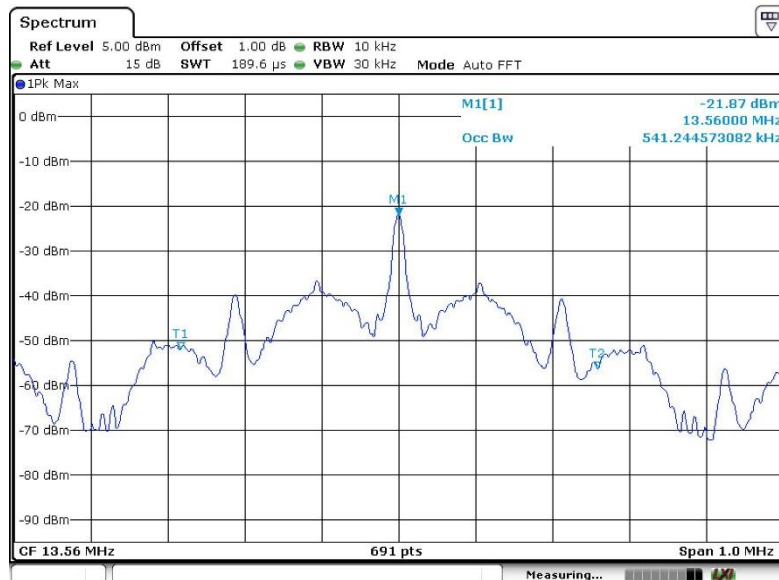

### 6.5. Radiated Emissions

#### LIMIT

For intentional device, according to § 15.209(a), the general requirement of field strength of radiated emission from intentional radiators at a distance of 3 meters shall not exceed the following table:

Frequency (MHz)	Distance(Meters)	Radiated(dBµV/m)	Radiated(µV/m)
0.009 - 0.490	300	$20 \cdot \log(2400/F(\text{kHz}))$	$2400/F(\text{kHz})$
0.490 - 1.705	30	$20 \cdot \log(24000/F(\text{kHz}))$	$24000/F(\text{kHz})$
1.705 - 30.0	30	29.54	30
30-88	3	40.0	100
88-216	3	43.5	150
216-960	3	46.0	200
Above 960	3	54.0	500

Remark:At frequencies below 30MHz, Limit 3m(dBuV)=Limit xm(dBuV)+20log(xm/3m);  
 At frequencies below 30MHz, Limit 3m(dBuV)=Limit xm(dBuV)+40log(xm/3m),x replace the number 10.30.300.

In addition to the provisions of §15.249, the field strength of emissions from intentional radiators operated under this section shall not exceed thefollowing:

Fundamental frequency	Field strength of fundamental (millivolts/meter)	Field strength of harmonics (microvolts/meter)
902-928 MHz	50	500
2400-2483.5 MHz	50	500
5725-5875 MHz	50	500
24.0-24.25 GHz	250	2500

#### TEST CONFIGURATION

Radiated Emission Test Set-Up  
 Frequency range 9KHz–30MHz

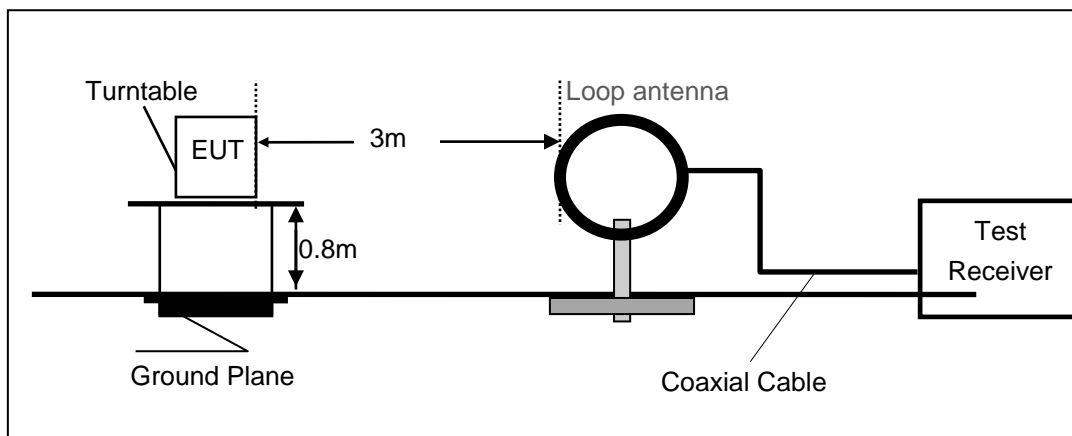

Frequency range 30MHz – 1000MHz

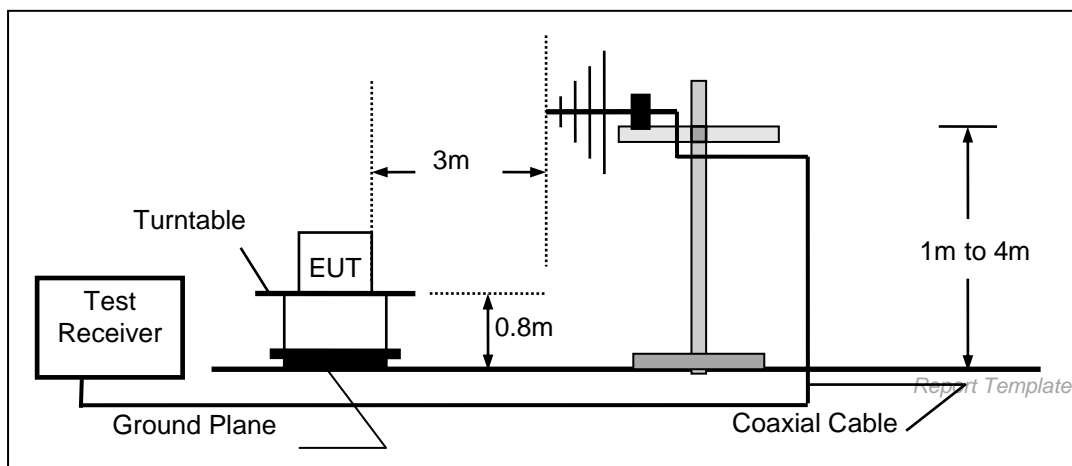



Frequency range above 1GHz-25GHz

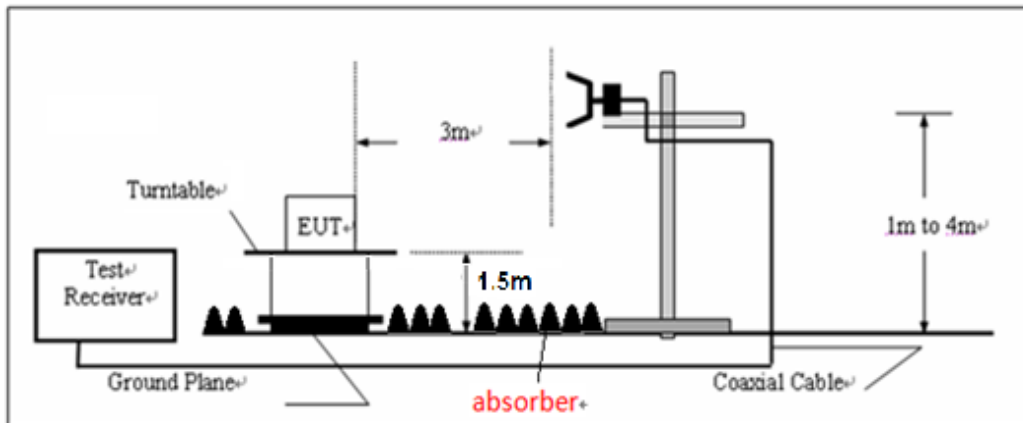

### TEST PROCEDURE

7. The EUT was tested according to ANSI C63.10:2013 for compliance to FCC 47CFR 15.247 requirements.
8. The EUT is placed on a turn table which is 0.8/1.5 meter above ground plane. The turn table is rotated 360 degrees to determine the position of the maximum emission level.
9. The EUT was positioned such that the distance from antenna to the EUT was 3 meters.
10. The antenna is scanned from 1 meter to 4 meters to find out the maximum emission level. This is repeated for both horizontal and vertical polarization of the antenna.
11. Use the following spectrum analyzer settings
  - (1) Span shall wide enough to fully capture the emission being measured;
  - (2) Below 1GHz, RBW=120KHz, VBW=300KHz, Sweep=auto, Detector function=peak, Trace=max hold;  
If the emission level of the EUT measured by the peak detector is 3 dB lower than the applicable limit, the peak emission level will be reported. Otherwise, the emission measurement will be repeated using the quasi-peak detector and reported.
  - (3) Above 1GHz, RBW=1MHz, VBW=3MHz Peak detector for Peak value  
RBW=1MHz, VBW=3MHz RMS detector for Average value.

Remark: "floor-standing equipment" Where possible, the antenna(s) of the EUT shall be located at a height of 1.5 m above the floor, and the intentional radiator circuitry shall be located within the system at a height of at least 0.8 m above the floor.

### TEST RESULTS

#### ■ 9kHz ~ 30MHz

The EUT was pre-scanned the frequency band (9KHz~30MHz), found the radiated level lower than the limit, so don't show on the report.

■ 30 MHz ~ 1 GHz

Polarization:

Vertical

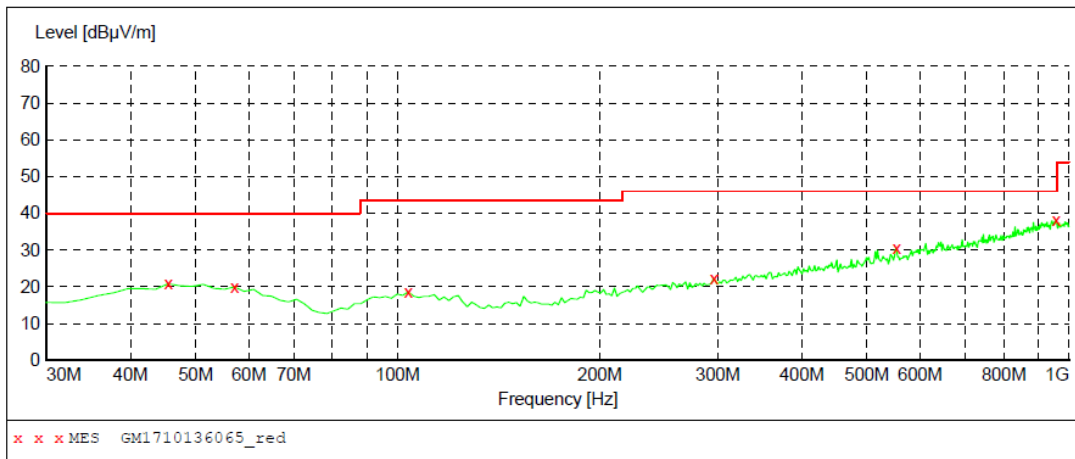

**MEASUREMENT RESULT: "GM1710136065\_red"**

10/13/2017 7:16PM

Frequency MHz	Level dBµV/m	Transd dB	Limit dBµV/m	Margin dB	Det.	Height cm	Azimuth deg	Polarization
45.520000	20.80	-8.8	40.0	19.2	QP	100.0	207.00	VERTICAL
57.160000	19.90	-9.4	40.0	20.1	QP	100.0	142.00	VERTICAL
103.720000	18.60	-10.5	43.5	24.9	QP	100.0	154.00	VERTICAL
295.780000	22.30	-7.3	46.0	23.7	QP	100.0	113.00	VERTICAL
553.800000	30.50	-0.7	46.0	15.5	QP	100.0	359.00	VERTICAL
957.320000	38.20	7.3	46.0	7.8	QP	100.0	286.00	VERTICAL

Polarization:

Horizontal

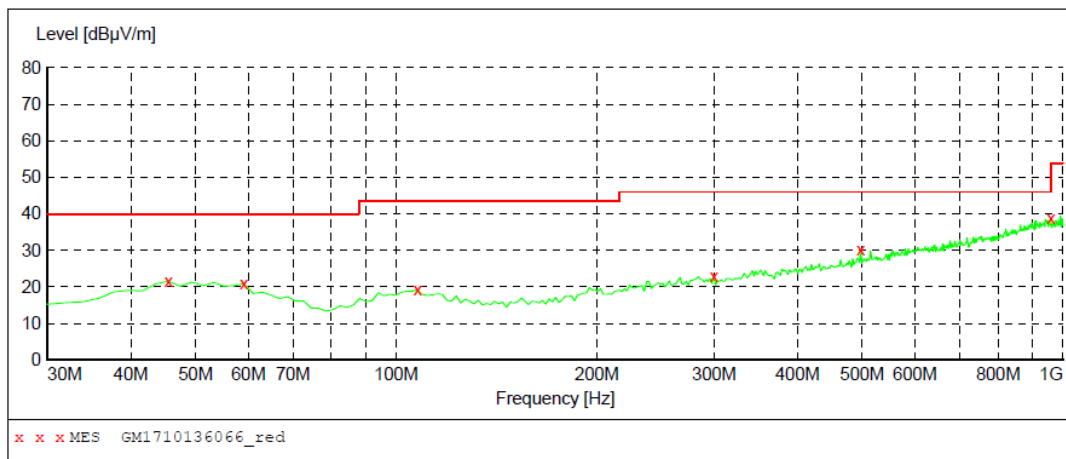

**MEASUREMENT RESULT: "GM1710136066\_red"**

10/13/2017 7:19PM

Frequency MHz	Level dBµV/m	Transd dB	Limit dBµV/m	Margin dB	Det.	Height cm	Azimuth deg	Polarization
45.520000	21.60	-8.8	40.0	18.4	QP	300.0	360.00	HORIZONTAL
59.100000	20.90	-9.8	40.0	19.1	QP	300.0	297.00	HORIZONTAL
107.600000	19.20	-10.6	43.5	24.3	QP	300.0	73.00	HORIZONTAL
299.660000	22.90	-7.3	46.0	23.1	QP	100.0	274.00	HORIZONTAL
497.540000	30.20	-1.8	46.0	15.8	QP	300.0	73.00	HORIZONTAL
959.260000	38.70	7.3	46.0	7.3	QP	300.0	136.00	HORIZONTAL

## 6.6. Frequency Stability Measurement

### LIMIT

The frequency tolerance of the carrier signal shall be maintained within +/- 0.01% of the operating frequency over a temperature variation of -20 degrees to +50 degrees C at normal supply voltage, for a variation in the primary supply voltage from 85% to 115% of the rated supply voltage at a temperature of 20 degrees C. For battery operated equipment, the equipment tests shall be performed using a new battery.

### TEST CONFIGURATION

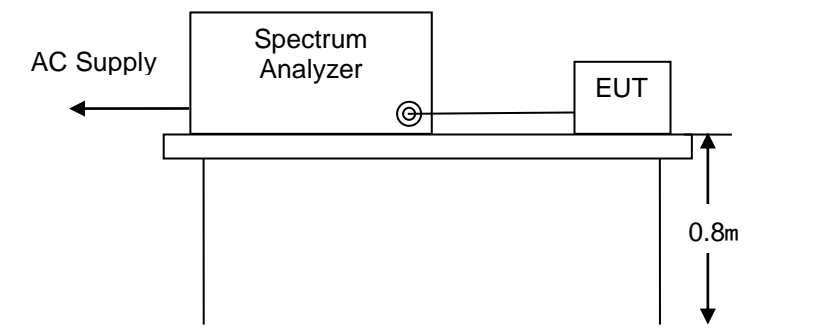

### TEST PROCEDURE

1. The transmitter output (antenna port) was connected to the spectrum analyzer.
2. EUT have transmitted absence of modulation signal and fixed channelize
3. Set the spectrum analyzer span to view the entire absence of modulation emissions bandwidth.
4. Set RBW=1KHz, VBW=1KHz with peak detector and maxhold settings.
5.  $f_c$  is declaring of channel frequency. Then the frequency error formula is  $(f_c - f) / f_c \times 10^6$  ppm and the limit is less than  $\pm 100$ ppm.
6. The test extreme voltage is to change the primary supply voltage from 85 to 115 percent of the nominal value
7. Extreme temperature rule is -20°C ~50°C

### TEST RESULTS

Reference Frequency: 13.56MHz					
Power supplied (Vdc)	Temperature (°C)	Frequency error		Limit(%)	Result
		Hz	%		
63.00	-20	43	0.00032	+/- 0.01	Pass
	-10	35	0.00026		
	0	57	0.00042		
	10	55	0.00041		
	20	61	0.00045		
	30	65	0.00048		
	40	66	0.00049		
	50	65	0.00048		

Reference Frequency: 13.56MHz					
Temperature (°C)	Power supplied (Vdc)	Frequency error		Limit(%)	Result
		Hz	%		
20	3.60	34	0.00025	+/- 0.01	Pass
	3.80	46	0.00034		
	4.35	55	0.00041		

## 7. Test Setup Photos of the EUT

Conducted Emissions (AC Mains)



Radiated Emissions

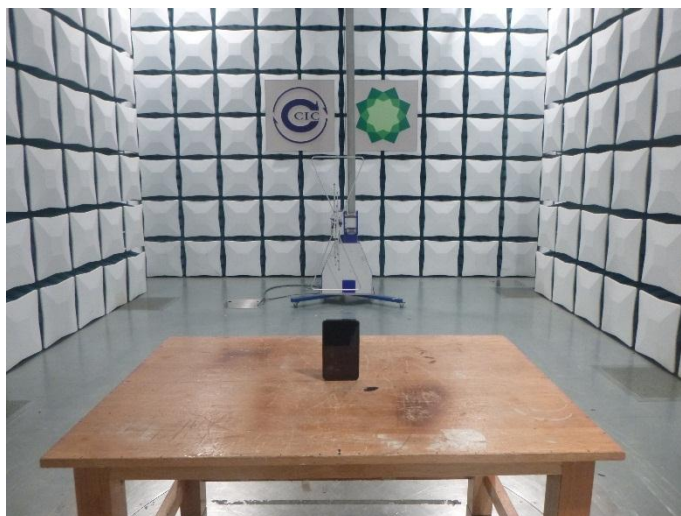

## 8. External and Internal Photos of the EUT

Reference to Test Report No.: TRE1709024401.

-----End of Report-----