



# TEST REPORT

**Report Reference No.**..... : **TRE1803009907**                      **R/C**.....: **71944**

**FCC ID**..... : **SS4RP350**

**Applicant's name**..... : **BLUEBIRD INC.**

**Address**..... : (Dogok-dong, SEI Tower 13,14) 39, Eonjuro30-gil, Gangnam-gu, Seoul, South Korea

**Manufacturer**..... : BLUEBIRD INC.

**Address**..... : (Dogok-dong, SEI Tower 13,14) 39, Eonjuro30-gil, Gangnam-gu, Seoul, South Korea

**Test item description** ..... : **Rugged Smart PTT Handheld Computer**

**Trade Mark** ..... : BLUEBIRD

**Model/Type reference**..... : RP350

**Listed Model(s)** ..... : -

**Standard** ..... : **FCC CFR Title 47 Part 15 Subpart C Section 15.225**

**Date of receipt of test sample**..... : Mar.13,2018

**Date of testing**..... : Mar.13,2018- Mar.27,2018

**Date of issue**..... : Mar.28,2018

**Result**..... : **PASS**

Compiled by  
( position+printedname+signature)....: File administrators Candy Liu *Candy Liu*

Supervised by  
(position+printedname+signature)....: Project Engineer Edward Pan *Edward Pan*

Approved by  
(position+printedname+signature)....: RF Manager Hans Hu *Hans Hu*

**Testing Laboratory Name** ..... : **Shenzhen Huatongwei International Inspection Co., Ltd.**

**Address**..... : 1/F, Bldg 3, Hongfa Hi-tech Industrial Park, Genyu Road, Tianliao, Gongming, Shenzhen, China

**Shenzhen Huatongwei International Inspection Co., Ltd. All rights reserved.**

This publication may be reproduced in whole or in part for non-commercial purposes as long as the Shenzhen Huatongwei International Inspection Co., Ltd. is acknowledged as copyright owner and source of the material. Shenzhen Huatongwei International Inspection Co., Ltd. takes no responsibility for and will not assume liability for damages resulting from the reader's interpretation of the reproduced material due to its placement and context.

*The test report merely correspond to the test sample.*

## Contents

<b>1.</b>	<b><u>TEST STANDARDS AND TEST DESCRIPTION</u></b>	<b>3</b>
1.1.	Test Standards	3
1.2.	Report version	3
<b>2.</b>	<b><u>TEST DESCRIPTION</u></b>	<b>4</b>
<b>3.</b>	<b><u>SUMMARY</u></b>	<b>5</b>
3.1.	Client Information	5
3.2.	Product Description	5
3.3.	EUT operation mode	6
3.4.	EUT configuration	6
3.5.	Modifications	6
<b>4.</b>	<b><u>TEST ENVIRONMENT</u></b>	<b>7</b>
4.1.	Address of the test laboratory	7
4.2.	Test Facility	7
4.3.	Environmental conditions	8
4.4.	Statement of the measurement uncertainty	8
4.5.	Equipments Used during the Test	9
<b>5.</b>	<b><u>TEST CONDITIONS AND RESULTS</u></b>	<b>11</b>
5.1.	Antenna requirement	11
5.2.	AC Power Conducted Emissions	12
5.3.	Field Strength of Fundamental Emission and Mask Measurement	15
5.4.	20 dB Occupied Bandwidth	17
5.5.	Radiated Emissions	18
5.6.	Frequency Stability Measurement	21
<b>6.</b>	<b><u>TEST SETUP PHOTOS OF THE EUT</u></b>	<b>23</b>
<b>7.</b>	<b><u>EXTERNAL AND INTERNAL PHOTOS OF THE EUT</u></b>	<b>23</b>

## **1. TEST STANDARDS AND TEST DESCRIPTION**

### **1.1. Test Standards**

The tests were performed according to following standards:

[FCC Rules Part 15.225](#): Operation within the band 13.110-14.010 MHz

[ANSI C63.10-2013](#): American National Standard for Testing Unlicensed Wireless Devices.

### **1.2. Report version**

Version No.	Date of issue	Description
N/A	Mar.28,2018	Original

## **2. Test Description**

<b>Test Item</b>	<b>FCC Rule</b>	<b>Result</b>	<b>Test Engineer</b>
Antenna requirement	15.203	Pass	Zhaohui ouyang
AC Power Line Conducted Emissions	15.207	Pass	Alex Guo
Field Strength of Fundamental Emissions and Mask Measurement	15.225	Pass	Jiuru Pan
20dB Occupied Bandwidth	15.215&15.215	Pass	Zhaohui ouyang
Radiated Emission	15.209	Pass	Jiuru Pan
Frequency Stability Measurement	15.225	Pass	Jiuru Pan

Remark: The measurement uncertainty is not included in the test result.

### 3. SUMMARY

#### 3.1. Client Information

Applicant:	BLUEBIRD INC.
Address:	(Dogok-dong, SEI Tower 13,14) 39, Eonjuro30-gil, Gangnam-gu, Seoul, South Korea
Manufacturer:	BLUEBIRD INC.
Address:	(Dogok-dong, SEI Tower 13,14) 39, Eonjuro30-gil, Gangnam-gu, Seoul, South Korea

#### 3.2. Product Description

Name of EUT:	Rugged Smart PTT Handheld Computer
Trade Mark:	BLUEBIRD
Model No.:	RP350
Listed Model(s):	-
Power supply:	DC 3.8V
Adapter information:	Input:100-240Va.c.,50/60Hz,0.5A Output: 5Vd.c.,2.0A
Hardware version:	V0.3
Software version:	R1.09
<b>NFC</b>	
Operation frequency:	13.56MHz
Channel number:	1
Modulation Type:	ASK
Antenna type:	Internal antenna
Antenna gain:	-3.0dBi

### 3.3. EUT operation mode

For RF test items
The engineering test program was provided and enabled to make EUT continuous transmit.
For AC power line conducted emissions:
The EUT was set to connect with large package sizes transmission.

### 3.4. EUT configuration

**The following peripheral devices and interface cables were connected during the measurement:**

- - supplied by the manufacturer
- - supplied by the lab

	Manufacturer :	/
	Model No. :	/
	Manufacturer :	/
	Model No. :	/

### 3.5. Modifications

No modifications were implemented to meet testing criteria.

## **4. TEST ENVIRONMENT**

### **4.1. Address of the test laboratory**

Laboratory: Shenzhen Huatongwei International Inspection Co., Ltd.

Address: 1/F, Bldg 3, Hongfa Hi-tech Industrial Park, Genyu Road, Tianliao, Gongming, Shenzhen, China

Phone: 86-755-26748019 Fax: 86-755-26748089

### **4.2. Test Facility**

The test facility is recognized, certified, or accredited by the following organizations:

#### **CNAS-Lab Code: L1225**

Shenzhen Huatongwei International Inspection Co., Ltd. has been assessed and proved to be in compliance with CNAS-CL01 Accreditation Criteria for Testing and Calibration Laboratories

(identical to ISO/IEC17025: 2005 General Requirements) for the Competence of Testing and Calibration Laboratories.

#### **A2LA-Lab Cert. No. 3902.01**

Shenzhen Huatongwei International Inspection Co., Ltd. EMC Laboratory has been accredited by A2LA for technical competence in the field of electrical testing, and proved to be in compliance with ISO/IEC 17025: 2005 General Requirements for the Competence of Testing and Calibration Laboratories and any additional program requirements in the identified field of testing.

#### **FCC-Registration No.: 762235**

Shenzhen Huatongwei International Inspection Co., Ltd. EMC Laboratory has been registered and fully described in a report filed with the FCC (Federal Communications Commission). The acceptance letter from the FCC is maintained in our files.

#### **IC-Registration No.: 5377B-1**

Two 3m Alternate Test Site of Shenzhen Huatongwei International Inspection Co., Ltd. has been registered by Certification and Engineering Bureau of Industry Canada for the performance of radiated measurements with Registration No. 5377B-1.

#### **ACA**

Shenzhen Huatongwei International Inspection Co., Ltd. EMC Laboratory can also perform testing for the Australian C-Tick mark as a result of our A2LA accreditation.

### 4.3. Environmental conditions

During the measurement the environmental conditions were within the listed ranges:

Temperature:	15~35°C
Relative Humidity:	30~60 %
Air Pressure:	950~1050mba

### 4.4. Statement of the measurement uncertainty

The data and results referenced in this document are true and accurate. The reader is cautioned that there may be errors in calibration limits of the equipment and facilities. The measurement uncertainty was calculated for all measurements listed in this test report according to TR-100028-01 "Electromagnetic compatibility and Radio spectrum Matters (ERM);Uncertainties in the measurement of mobile radio equipment characteristics;Part 1" and TR-100028-02 "Electromagnetic compatibility and Radio spectrum Matters (ERM);Uncertainties in the measurement of mobile radio equipment characteristics;Part 2" and is documented in the Shenzhen Huatongwei International Inspection Co., Ltd quality system according to ISO/IEC 17025. Further more, component and process variability of devices similar to that tested may result in additional deviation. The manufacturer has the sole responsibility of continued compliance of the device.

Here after the best measurement capability for Shenzhen Huatongwei is reported:

Test Items	Measurement Uncertainty	Notes
Conducted spurious emissions 9KHz-30MHz	3.39 dB	(1)
Radiated Emissions 30~1000MHz	4.24 dB	(1)
Radiated Emissions 1~18GHz	5.16 dB	(1)
Radiated Emissions 18-40GHz	5.54 dB	(1)
Occupied Bandwidth	-----	(1)

(1) This uncertainty represents an expanded uncertainty expressed at approximately the 95% confidence level using a coverage factor of  $k=1.96$ .



#### 4.5. Equipments Used during the Test

Conducted Emissions						
Item	Test Equipment	Manufacturer	Model No.	Serial No.	Last Cal. (mm-dd-yy)	Next Cal. (mm-dd-yy)
1	EMI Test Receiver	R&S	ESCI	101247	11/11/2017	11/10/2018
2	Artificial Mains	SCHWARZBECK	NNLK 8121	573	11/11/2017	11/10/2018
3	2-Line V-Network	R&S	ESH3-Z5	100049	11/11/2017	11/10/2018
4	Pulse Limiter	R&S	ESH3-Z2	101488	11/11/2017	11/10/2018
5	RF Connection Cable	HUBER+SUHNER	EF400	N/A	11/21/2017	11/20/2018
6	Test Software	R&S	ES-K1	N/A	N/A	N/A

Radiated Emissions						
Item	Test Equipment	Manufacturer	Model No.	Serial No.	Last Cal. (mm-dd-yy)	Next Cal. (mm-dd-yy)
1	EMI Test Receiver	R&S	ESCI	101247	11/11/2017	11/10/2018
2	Loop Antenna	R&S	HFH2-Z2	100020	11/20/2017	11/19/2018
3	Ultra-Broadband Antenna	SCHWARZBECK	VULB9163	538	4/5/2017	4/4/2020
4	Preamplifier	SCHWARZBECK	BBV 9743	9743-0022	10/18/2017	10/17/2018
5	RF Connection Cable	HUBER+SUHNER	RE-7-FL	N/A	11/21/2017	11/20/2018
6	EMI Test Software	R&S	ESK1	N/A	N/A	N/A
7	Spectrum Analyzer	R&S	FSP40	100597	11/11/2017	11/10/2018
8	Horn Antenna	SCHWARZBECK	9120D	1011	3/27/2017	3/26/2020
9	Horn Antenna	SCHWARZBECK	BBHA9170	25841	3/27/2017	3/26/2018
10	Broadband Preamplifier	SCHWARZBECK	BBV 9718	9718-248	10/18/2017	10/17/2018
11	High pass filter	Compliance Direction systems	BSU-6	34202	11/11/2017	11/10/2018
12	RF Connection Cable	HUBER+SUHNER	RE-7-FH	N/A	11/21/2017	11/20/2018
13	EMI Test Software	Audix	E3	N/A	N/A	N/A
14	Turntable	MATURO	TT2.0	N/A	N/A	N/A
15	Antenna Mast	MATURO	TAM-4.0-P	N/A	N/A	N/A

<b>RF Conducted Test</b>						
Item	Test Equipment	Manufacturer	Model No.	Serial No.	Last Cal. (mm-dd-yy)	Next Cal. (mm-dd-yy)
1	Spectrum Analyzer	R&S	FSV40	100048	11/11/2017	11/10/2018
2	EXA Signal Analyzer	Agilent	N9020A	184247	9/22/2017	9/21/2018
3	Power Meter	Anritsu	ML249A	N/A	9/22/2017	9/21/2018
4	OSP	R&S	OSP120	101317	N/A	N/A

## 5. TEST CONDITIONS AND RESULTS

### 5.1. Antenna requirement

#### Requirement

##### **FCC CFR Title 47 Part 15 Subpart C Section 15.203:**

An intentional radiator shall be designed to ensure that no antenna other than that furnished by the responsible party shall be used with the device. The use of a permanently attached antenna or of an antenna that uses a unique coupling to the intentional radiator, the manufacturer may design the unit so that a broken antenna can be replaced by the user, but the use of a standard antenna jack or electrical connector is prohibited.

#### **Refer to statement below for compliance.**

The manufacturer may design the unit so that the user can replace a broken antenna, but the use of a standard antenna jack or electrical connector is prohibited. Further, this requirement does not apply to intentional radiators that must be professionally installed.

#### Test Result:

The directional gain of the antenna less than 6 dBi, please refer to the below antenna photo.

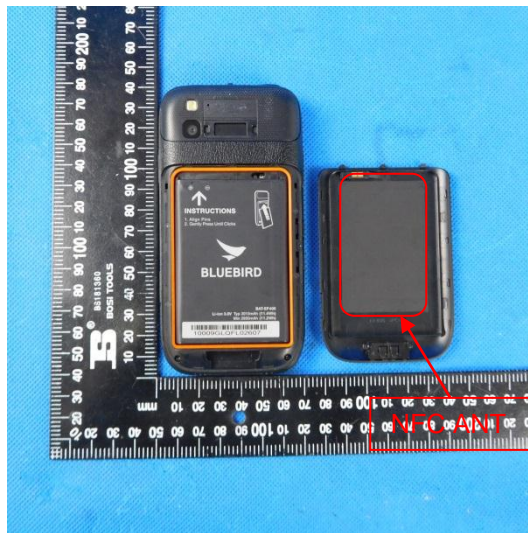

## 5.2. AC Power Conducted Emissions

### LIMIT

FCC CFR Title 47 Part 15 Subpart C Section 15.207:

Frequency range (MHz)	Limit (dBuV)	
	Quasi-peak	Average
0.15-0.5	66 to 56*	56 to 46*
0.5-5	56	46
5-30	60	50

\* Decreases with the logarithm of the frequency.

### TEST CONFIGURATION

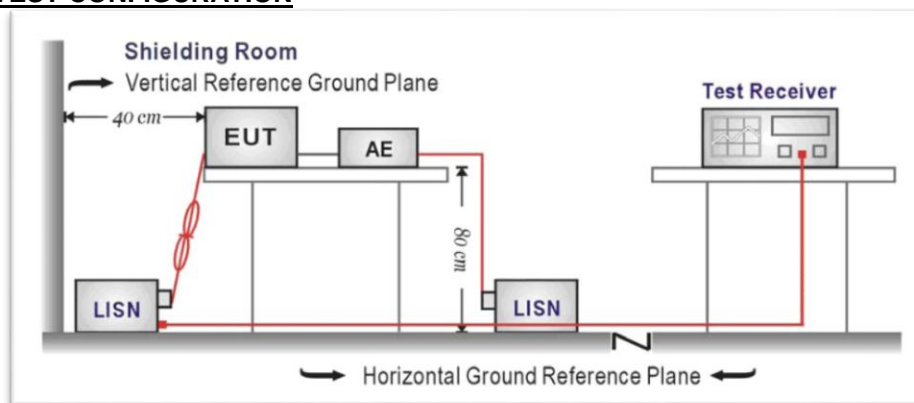

### TEST PROCEDURE

1. The EUT was setup according to ANSI C63.10:2013 for compliance to FCC 47CFR 15.247 requirements.
2. The EUT was placed on a platform of nominal size, 1 m by 1.5 m, raised 10 cm above the conducting ground plane. The vertical conducting plane was located 40 cm to the rear of the EUT. All other surfaces of EUT were at least 10 cm from any other grounded conducting surface.
3. The EUT and simulators are connected to the main power through a line impedance stabilization network (LISN). The LISN provides a 50ohm / 50uH coupling impedance for the measuring equipment.
4. The peripheral devices are also connected to the main power through a LISN. (Please refer to the block diagram of the test setup and photographs)
5. Each current-carrying conductor of the EUT power cord, except the ground (safety) conductor, was individually connected through a LISN to the input power source.
6. The excess length of the power cord between the EUT and the LISN receptacle were folded back and forth at the center of the lead to form a bundle not exceeding 40 cm in length.
7. Conducted emissions were investigated over the frequency range from 0.15MHz to 30MHz using a receiver bandwidth of 9 kHz.
8. During the above scans, the emissions were maximized by cable manipulation.

**TEST RESULTS**

Test Line: L

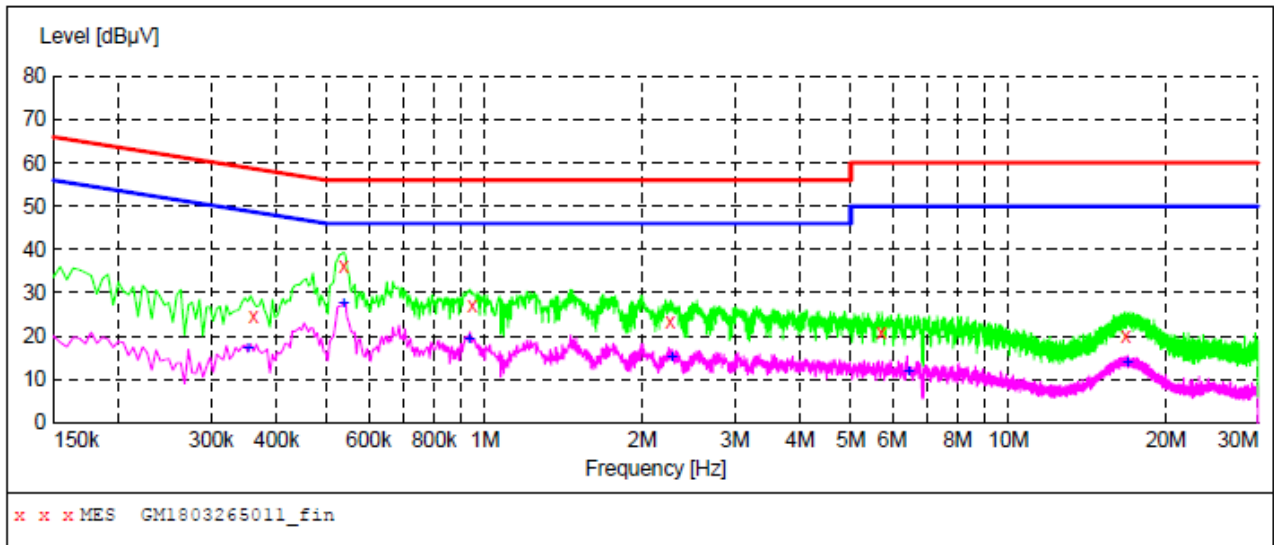

**MEASUREMENT RESULT: "GM1803265011\_fin"**

3/26/2018 9:24AM

Frequency MHz	Level dBµV	Transd dB	Limit dBµV	Margin dB	Detector	Line	PE
0.361500	24.60	9.9	59	34.1	QP	L1	GND
0.537000	36.20	10.0	56	19.8	QP	L1	GND
0.946500	27.20	10.0	56	28.8	QP	L1	GND
2.256000	23.50	10.1	56	32.5	QP	L1	GND
5.712000	20.90	10.2	60	39.1	QP	L1	GND
16.746000	19.90	10.5	60	40.1	QP	L1	GND

**MEASUREMENT RESULT: "GM1803265011\_fin2"**

3/26/2018 9:24AM

Frequency MHz	Level dBµV	Transd dB	Limit dBµV	Margin dB	Detector	Line	PE
0.352500	17.00	9.9	49	31.9	AV	L1	GND
0.537000	27.60	10.0	46	18.4	AV	L1	GND
0.933000	19.10	10.0	46	26.9	AV	L1	GND
2.274000	15.10	10.1	46	30.9	AV	L1	GND
6.445500	11.70	10.2	50	38.3	AV	L1	GND
16.899000	13.70	10.6	50	36.3	AV	L1	GND

Test Line: N

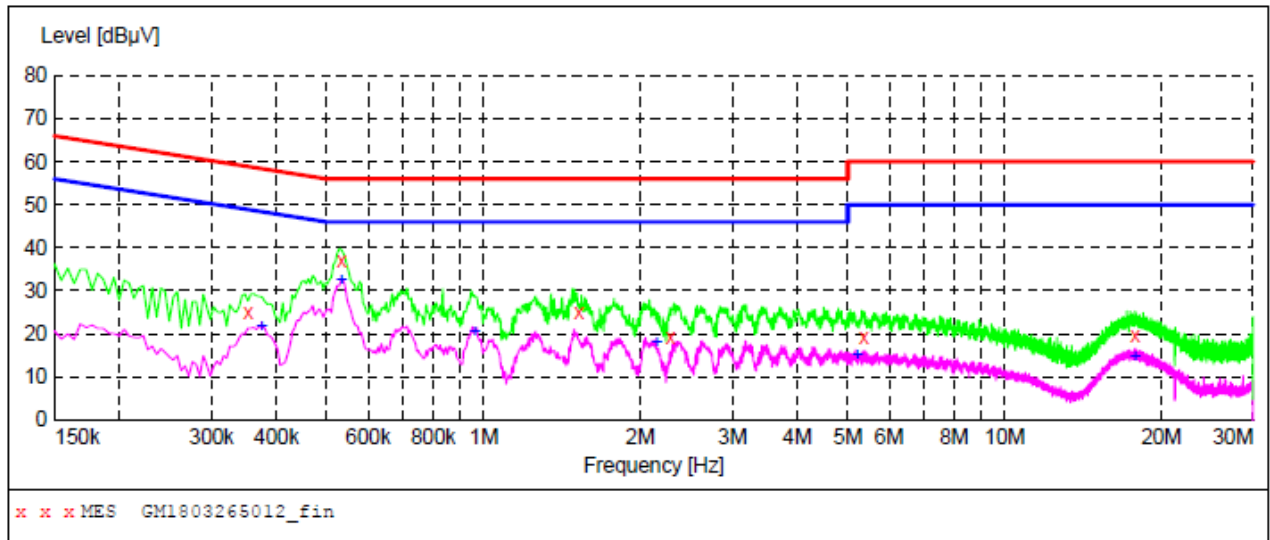

**MEASUREMENT RESULT: "GM1803265012\_fin"**

3/26/2018 9:26AM

Frequency MHz	Level dBµV	Transd dB	Limit dBµV	Margin dB	Detector	Line	PE
0.352500	25.00	9.9	59	33.9	QP	N	GND
0.532500	37.10	10.0	56	18.9	QP	N	GND
1.522500	25.10	10.1	56	30.9	QP	N	GND
2.283000	19.20	10.1	56	36.8	QP	N	GND
5.361000	19.30	10.2	60	40.7	QP	N	GND
17.821500	19.70	10.6	60	40.3	QP	N	GND

**MEASUREMENT RESULT: "GM1803265012\_fin2"**

3/26/2018 9:26AM

Frequency MHz	Level dBµV	Transd dB	Limit dBµV	Margin dB	Detector	Line	PE
0.375000	21.80	9.9	48	26.6	AV	N	GND
0.532500	32.30	10.0	46	13.7	AV	N	GND
0.960000	20.60	10.0	46	25.4	AV	N	GND
2.143500	18.00	10.1	46	28.0	AV	N	GND
5.212500	15.00	10.2	50	35.0	AV	N	GND
17.785500	14.60	10.6	50	35.4	AV	N	GND

### 5.3. Field Strength of Fundamental Emission and Mask Measurement

#### Limit

Operation frequency range 13.11MHz~14.01MHz.

According to ANSI C63:10-2013 Clause 6.4.4. The measured distance great than  $\lambda/2\pi$  at 13.56MHz. So the measured field strength is

$$FS_{\text{limit}} = FS_{\text{max}} - 20 \log \left( \frac{d_{\text{limit}}}{d_{\text{measure}}} \right)$$

$FS_{\text{limit}}$  is the calculation of field strength at the limit distance, expressed in dB $\mu$ V/m

$FS_{\text{max}}$  is the measured field strength, expressed in dB $\mu$ V/m

$d_{\text{near}}$  field is the  $\lambda/2\pi$  distance

$d_{\text{measure}}$  is the distance of the measurement point from the EUT

$d_{\text{limit}}$  is the reference limit distance

Frequency (MHz)	Field Strength (microvolts/meter) at 30m	Field Strength (dB $\mu$ V/m) at 3m
1.705~13.110	30	49.5
13.110~13.410	106	60.5
13.410~13.553	334	70.5
13.553~13.567	15848	104.0
13.567~13.710	334	70.5
13.710~14.010	106	70.5
14.010~30.000	30	49.5

#### TEST CONFIGURATION

Radiated Emission Test Set-Up

Frequency range 9KHz~30MHz

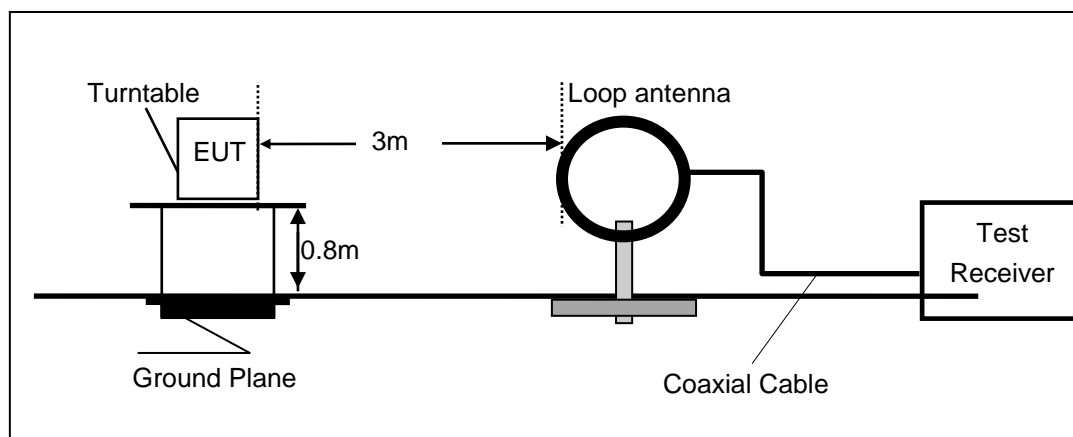

#### TEST PROCEDURE

1. The EUT was tested according to ANSI C63.10:2013 for compliance to FCC 47CFR 15.225 requirements.
2. The EUT is placed on a turn table which is 0.8 meter above ground plane. The turn table is rotated 360 degrees to determine the position of the maximum emission level.
3. The EUT was positioned such that the distance from antenna to the EUT was 3 meters.
4. The antenna is scanned from 1 meter to 4 meters to find out the maximum emission level. This is repeated for both horizontal and vertical polarization of the antenna.
5. Use the following spectrum analyzer settings
6. Span shall wide enough to fully capture the emission being measured;
  - (1) Span shall wide enough to fully capture the emission being measured;
  - (2) From 13.11MHz to 14.01MHz, RBW=10KHz, VBW=30KHz, Sweep=auto, Detector function=peak,

- (3) Below 1GHz, RBW=120KHz, VBW=300KHz, Sweep=auto, Detector function=peak, Trace=max hold; If the emission level of the EUT measured by the peak detector is 3 dB lower than the applicable limit, the peak emission level will be reported. Otherwise, the emission measurement will be repeated using the quasi-peak detector and reported.

**TEST RESULTS**

Frequency MHz	Mea.Frequency MHz	Test result (dB $\mu$ V/m@3m)	Limit (dBuV/m @3m)	Margin dB	Det.	Result
13.110~13.410	13.400	24.38	60.50	-36.12	Quasi	Pass
13.410~13.553	13.551	24.57	70.50	-45.93	Quasi	Pass
13.553~13.567	13.560	48.61	104.00	-55.39	Quasi	Pass
13.567~13.710	13.568	24.22	70.50	-46.28	Quasi	Pass
13.710~14.010	13.710	24.34	65.50	-41.16	Quasi	Pass



### 5.4. 20 dB Occupied Bandwidth

**Limit**

Operation frequency range 13.11MHz~14.01MHz.

**TEST CONFIGURATION**

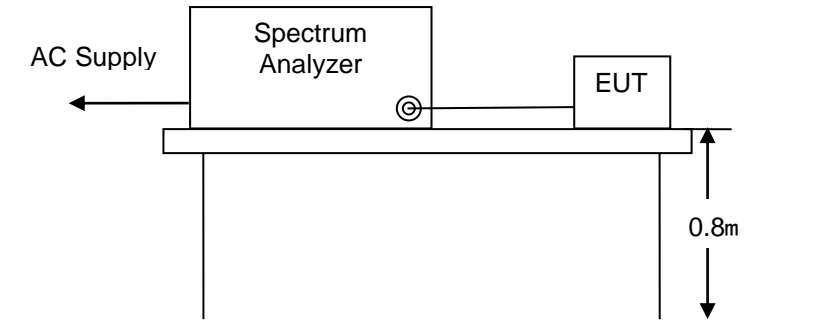

**TEST PROCEDURE**

- 1.As required by 47 CFR 15.215 and 47 CFR 15.225
2. The EUT connected to the spectrum analyzer was operated in linear scale and 2.0MHz span mode after tuning to the transmitter frequency.

**TEST RESULTS**

Frequency(MHz)	20dB Bandwidth(KHz)	Result
13.56	83.90	PASS

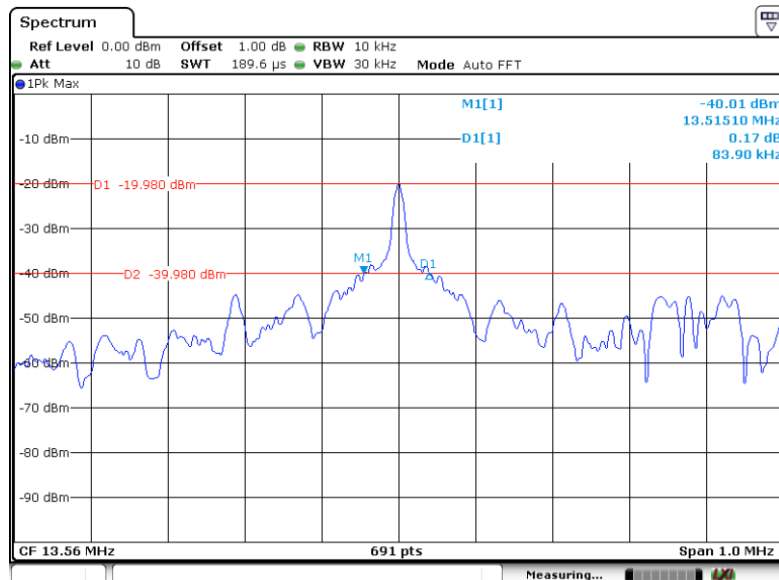

### 5.5. Radiated Emissions

#### LIMIT

For intentional device, according to § 15.209(a), the general requirement of field strength of radiated emission from intentional radiators at a distance of 3 meters shall not exceed the following table:

Frequency (MHz)	Distance(Meters)	Radiated(dBµV/m)	Radiated(µV/m)
0.009 - 0.490	300	$20 \cdot \log(2400/F(\text{kHz}))$	$2400/F(\text{kHz})$
0.490 - 1.705	30	$20 \cdot \log(24000/F(\text{kHz}))$	$24000/F(\text{kHz})$
1.705 - 30.0	30	29.54	30
30-88	3	40.0	100
88-216	3	43.5	150
216-960	3	46.0	200
Above 960	3	54.0	500

Remark:At frequencies below 30MHz, Limit 3m(dBuV)=Limit xm(dBuV)+20log(xm/3m);  
 At frequencies below 30MHz, Limit 3m(dBuV)=Limit xm(dBuV)+40log(xm/3m),x replace the number 10.30.300.

In addition to the provisions of §15.249, the field strength of emissions from intentional radiators operated under this section shall not exceed thefollowing:

Fundamental frequency	Field strength of fundamental (millivolts/meter)	Field strength of harmonics (microvolts/meter)
902-928 MHz	50	500
2400-2483.5 MHz	50	500
5725-5875 MHz	50	500
24.0-24.25 GHz	250	2500

#### TEST CONFIGURATION

Radiated Emission Test Set-Up  
 Frequency range 9KHz–30MHz

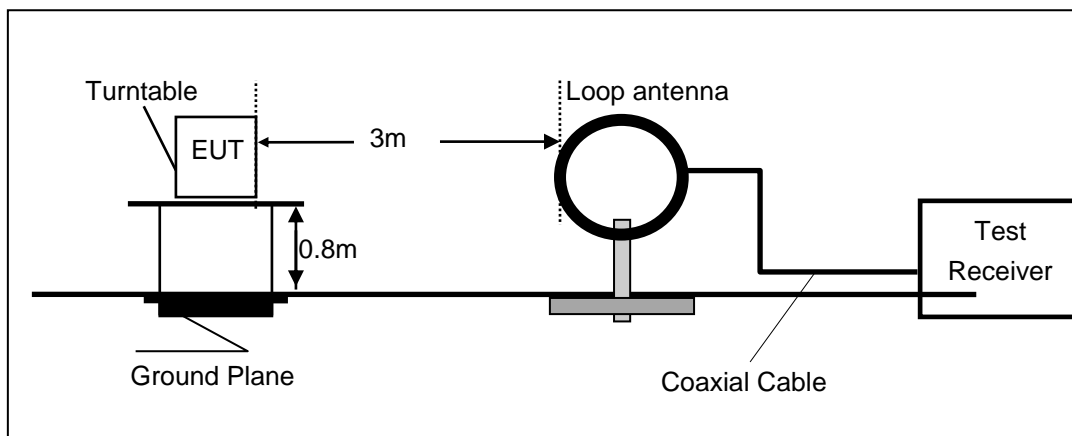

Frequency range 30MHz – 1000MHz

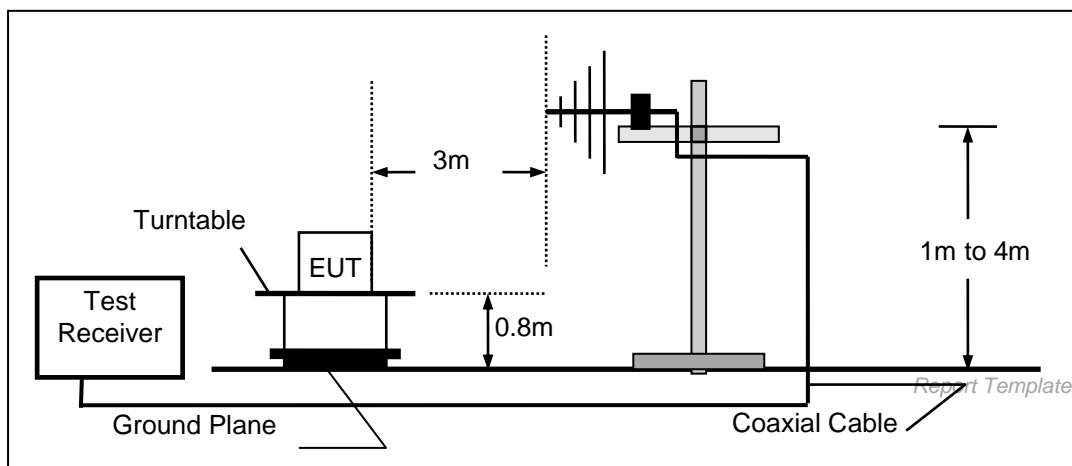

Frequency range above 1GHz-25GHz

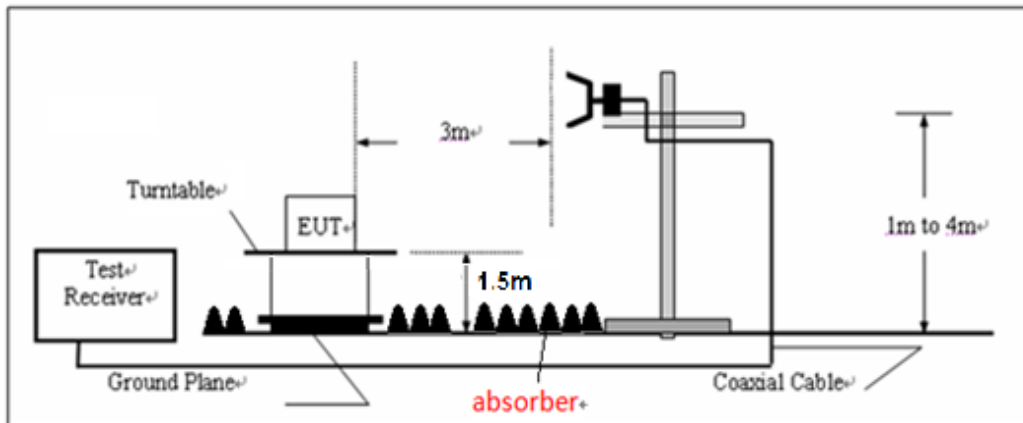

### TEST PROCEDURE

7. The EUT was tested according to ANSI C63.10:2013 for compliance to FCC 47CFR 15.247 requirements.
8. The EUT is placed on a turn table which is 0.8/1.5 meter above ground plane. The turn table is rotated 360 degrees to determine the position of the maximum emission level.
9. The EUT was positioned such that the distance from antenna to the EUT was 3 meters.
10. The antenna is scanned from 1 meter to 4 meters to find out the maximum emission level. This is repeated for both horizontal and vertical polarization of the antenna.
11. Use the following spectrum analyzer settings
  - (1) Span shall wide enough to fully capture the emission being measured;
  - (2) Below 1GHz, RBW=120KHz, VBW=300KHz, Sweep=auto, Detector function=peak, Trace=max hold; If the emission level of the EUT measured by the peak detector is 3 dB lower than the applicable limit, the peak emission level will be reported. Otherwise, the emission measurement will be repeated using the quasi-peak detector and reported.
  - (3) Above 1GHz, RBW=1MHz, VBW=3MHz Peak detector for Peak value  
RBW=1MHz, VBW=3MHz RMS detector for Average value.

Remark: "floor-standing equipment" Where possible, the antenna(s) of the EUT shall be located at a height of 1.5 m above the floor, and the intentional radiator circuitry shall be located within the system at a height of at least 0.8 m above the floor.

### TEST RESULTS

#### ■ 9kHz ~ 30MHz

The EUT was pre-scanned the frequency band (9KHz~30MHz), found the radiated level lower than the limit, so don't show on the report.

■ 30 MHz ~ 1 GHz

Polarization:

Vertical

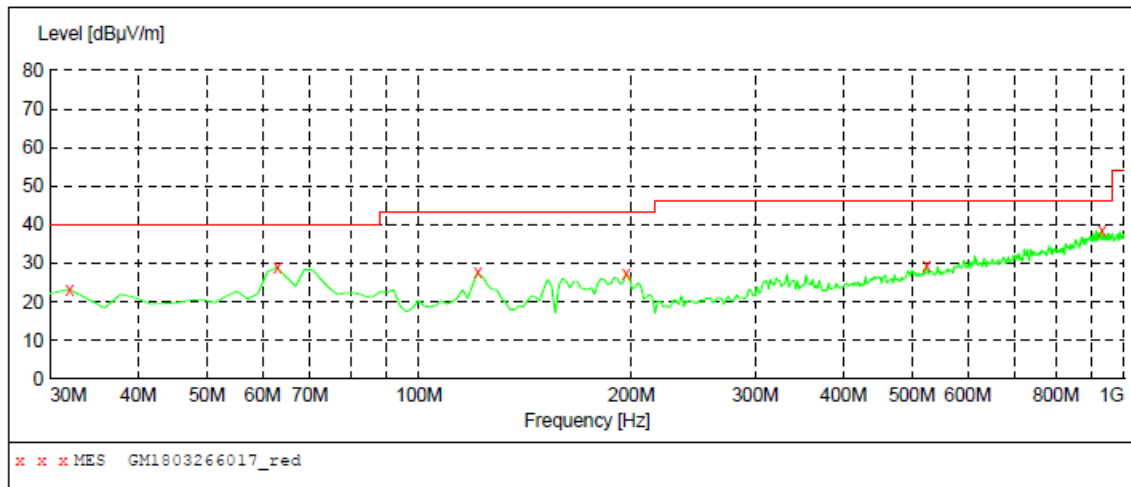

**MEASUREMENT RESULT: "GM1803266017\_red"**

3/26/2018 9:55AM

Frequency MHz	Level dBµV/m	Transd dB	Limit dBµV/m	Margin dB	Det.	Height cm	Azimuth deg	Polarization
31.940000	23.30	-13.2	40.0	16.7	QP	100.0	360.00	VERTICAL
62.980000	28.90	-10.8	40.0	11.1	QP	100.0	0.00	VERTICAL
121.180000	27.50	-12.5	43.5	16.0	QP	100.0	113.00	VERTICAL
196.840000	27.40	-9.8	43.5	16.1	QP	100.0	44.00	VERTICAL
524.700000	29.30	-1.2	46.0	16.7	QP	100.0	33.00	VERTICAL
930.160000	38.70	7.1	46.0	7.3	QP	100.0	142.00	VERTICAL

Polarization:

Horizontal

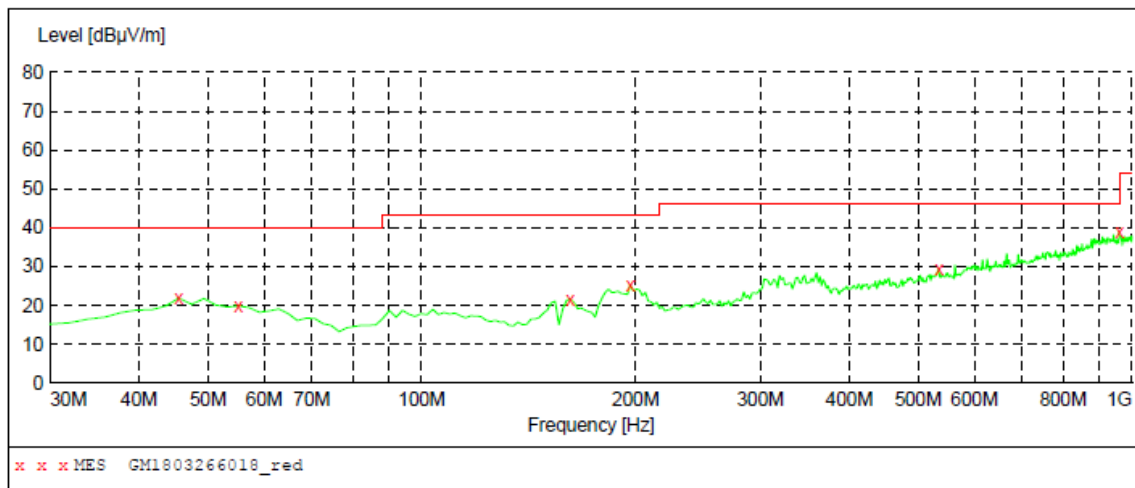

**MEASUREMENT RESULT: "GM1803266018\_red"**

3/26/2018 9:57AM

Frequency MHz	Level dBµV/m	Transd dB	Limit dBµV/m	Margin dB	Det.	Height cm	Azimuth deg	Polarization
45.520000	21.90	-8.8	40.0	18.1	QP	100.0	0.00	HORIZONTAL
55.220000	19.90	-9.2	40.0	20.1	QP	100.0	291.00	HORIZONTAL
161.920000	21.70	-13.3	43.5	21.8	QP	100.0	211.00	HORIZONTAL
196.840000	25.20	-9.8	43.5	18.3	QP	100.0	0.00	HORIZONTAL
534.400000	29.20	-1.1	46.0	16.8	QP	100.0	238.00	HORIZONTAL
959.260000	38.80	7.3	46.0	7.2	QP	100.0	170.00	HORIZONTAL

## 5.6. Frequency Stability Measurement

### LIMIT

The frequency tolerance of the carrier signal shall be maintained within +/- 0.01% of the operating frequency over a temperature variation of -20 degrees to +50 degrees C at normal supply voltage, for a variation in the primary supply voltage from 85% to 115% of the rated supply voltage at a temperature of 20 degrees C. For battery operated equipment, the equipment tests shall be performed using a new battery.

### TEST CONFIGURATION

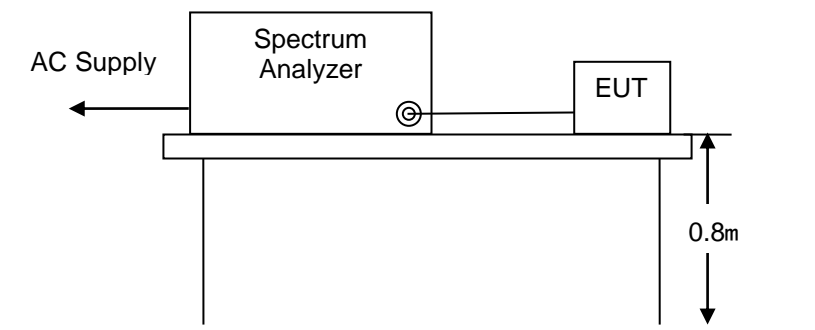

### TEST PROCEDURE

1. The transmitter output (antenna port) was connected to the spectrum analyzer.
2. EUT have transmitted absence of modulation signal and fixed channelize
3. Set the spectrum analyzer span to view the entire absence of modulation emissions bandwidth.
4. Set RBW=1KHz, VBW=1KHz with peak detector and maxhold settings.
5.  $f_c$  is declaring of channel frequency. Then the frequency error formula is  $(f_c - f) / f_c \times 10^6$  ppm and the limit is less than  $\pm 100$ ppm.
6. The test extreme voltage is to change the primary supply voltage from 85 to 115 percent of the nominal value
7. Extreme temperature rule is -20°C ~50°C

### TEST RESULTS

Reference Frequency: 13.56MHz					
Power supplied (Vdc)	Temperature (°C)	Frequency error		Limit(%)	Result
		Hz	%		
3.8	-20	25.00	0.00018	+/- 0.01	Pass
	-10	23.00	0.00017		
	0	23.00	0.00017		
	10	32.00	0.00024		
	20	35.00	0.00026		
	30	38.00	0.00028		
	40	32.00	0.00024		
	50	38.00	0.00028		

Reference Frequency: 13.56MHz					
Temperature (°C)	Power supplied (Vdc)	Frequency error		Limit(%)	Result
		Hz	%		
20	3.60	33.00	0.00024	+/- 0.01	Pass
	3.80	46.00	0.00034		
	4.35	48.00	0.00035		

## 6. Test Setup Photos of the EUT

Conducted Emissions (AC Mains)



Radiated Emissions



## 7. External and Internal Photos of the EUT

Reference to the test report No.: TRE1803009901.

-----End of Report-----