



FCC REPORT

Report Reference No..... : **TRE1803009903** R/C.....: **71944**

FCC ID..... : **SS4RP350**

Applicant's name..... : **BLUEBIRD INC.**

Manufacturer.....: (Dogok-dong, SEI Tower 13,14) 39, Eonjuro30-gil, Gangnam-gu, Seoul, South Korea

Address.....: BLUEBIRD INC.

Test item description : (Dogok-dong, SEI Tower 13,14) 39, Eonjuro30-gil, Gangnam-gu, Seoul, South Korea

Trade Mark : **Rugged Smart PTT Handheld Computer**

Model/Type reference.....: BLUEBIRD

Listed Model(s): RP350

Standard : **FCC CFR Title 47 Part 2**
FCC CFR Title 47 Part 22
FCC CFR Title 47 Part 24
FCC CFR Title 47 Part 27

Date of receipt of test sample.....: Mar.13,2018

Date of testing.....: Mar.13,2018- Mar.27,2018

Date of issue.....: Mar.28,2018

Result.....: **Pass**

Compiled by
(position+printedname+signature)....: File administrators Candy Liu

Supervised by
(position+printedname+signature)....: Project Engineer Edward Pan

Approved by
(position+printedname+signature)....: Manager Hans Hu

Testing Laboratory Name : **Shenzhen Huatongwei International Inspection Co., Ltd.**

Address.....: 1/F, Bldg 3, Hongfa Hi-tech Industrial Park, Genyu Road, Tianliao, Gongming, Shenzhen, China

Shenzhen Huatongwei International Inspection Co., Ltd. All rights reserved.

This publication may be reproduced in whole or in part for non-commercial purposes as long as the Shenzhen Huatongwei International Inspection Co., Ltd. is acknowledged as copyright owner and source of the material. Shenzhen Huatongwei International Inspection Co., Ltd. takes no responsibility for and will not assume liability for damages resulting from the reader's interpretation of the reproduced material due to its placement and context.

The test report merely correspond to the test sample.

Contents

1.	<u>TEST STANDARDS AND REPORT VERSION</u>	3
1.1.	Applicable Standards	3
1.2.	Report version	3
2.	<u>TEST DESCRIPTION</u>	4
3.	<u>SUMMARY</u>	5
3.1.	Client Information	5
3.2.	Product Description	5
3.3.	Operation state	7
3.4.	EUT operation mode	8
3.5.	EUT configuration	9
3.6.	Modifications	9
4.	<u>TEST ENVIRONMENT</u>	10
4.1.	Address of the test laboratory	10
4.2.	Test Facility	10
4.3.	Equipments Used during the Test	11
4.4.	Environmental conditions	12
4.5.	Statement of the measurement uncertainty	12
5.	<u>TEST CONDITIONS AND RESULTS</u>	13
5.1.	Conducted Output Power	13
5.2.	Peak-to-Average Ratio	14
5.3.	99% Occupied Bandwidth & 26 dB Bandwidth	15
5.4.	Band Edge	16
5.5.	Conducted Spurious Emissions	17
5.6.	Frequency stability VS Temperature measurement	18
5.7.	Frequency stability VS Voltage measurement	19
5.8.	ERP and EIRP	20
5.9.	Radiated Spurious Emission	28
6.	<u>TEST SETUP PHOTOS</u>	39
7.	<u>EXTERNAL AND INTERNAL PHOTOS</u>	39
8.	<u>APPENDIX REPORT</u>	39

1. TEST STANDARDS AND REPORT VERSION

1.1. Applicable Standards

The tests were performed according to following standards:

[FCC Rules Part 2](#): FREQUENCY ALLOCATIONS AND RADIO TREATY MATTERS; GENERAL RULES AND REGULATIONS

[FCC Rules Part 22](#): PRIVATE LAND MOBILE RADIO SERVICES.

[FCC Rules Part 24](#): PUBLIC MOBILE SERVICES

[FCC Rules Part 27](#): MISCELLANEOUS WIRELESS COMMUNICATIONS SERVICES

[ANSI C63.26: 2015](#): American National Standard for Compliance Testing of Transmitters Used in Licensed Radio Services

[KDB 971168 D01 Power Meas License Digital Systems v03](#): MEASUREMENT GUIDANCE FOR CERTIFICATION OF LICENSED DIGITAL TRANSMITTERS

1.2. Report version

Revised No.	Date of issue	Description
N/A	Mar.28,2018	Original

2. Test Description

Test Item	Section in CFR 47	Result	Test Engineer
Conducted Output Power	Part 2.1046 Part 22.913(a) Part 24.232(c) Part 27.50	Pass	Aaron Fang
Peak-to-Average Ratio	Part 24.232 Part 27.50	Pass	Aaron Fang
99% Occupied Bandwidth & 26 dB Bandwidth	Part 2.1049 Part 22.917(b) Part 24.238(b) Part 27.53	Pass	Aaron Fang
Band Edge	Part 2.1051 Part 22.917 Part 24.238 Part 27.53	Pass	Aaron Fang
Conducted Spurious Emissions	Part 2.1051 Part 22.917 Part 24.238 Part 27.53	Pass	Aaron Fang
Frequency stability VS Temperature	Part 2.1055(a)(1)(b) Part 22.355 Part 24.235 Part 27.54	Pass	Aaron Fang
Frequency stability VS Voltage	Part 2.1055(d)(1)(2) Part 22.355 Part 24.235 Part 27.54	Pass	Aaron Fang
ERP and EIRP	Part 22.913(a) Part 24.232(b) Part 27.50	Pass	Jiuru Pan
Radiated Spurious Emissions	Part 2.1053 Part 22.917 Part 24.238 Part 27.53	Pass	Jiuru Pan

Note: The measurement uncertainty is not included in the test result.

3. SUMMARY

3.1. Client Information

Applicant:	BLUEBIRD INC.
Address:	(Dogok-dong, SEI Tower 13,14) 39, Eonjuro30-gil, Gangnam-gu, Seoul, South Korea
Manufacturer:	BLUEBIRD INC.
Address:	(Dogok-dong, SEI Tower 13,14) 39, Eonjuro30-gil, Gangnam-gu, Seoul, South Korea

3.2. Product Description

Name of EUT:	Rugged Smart PTT Handheld Computer		
Trade Mark:	BLUEBIRD		
Model No.:	RP350		
Listed Model(s):	-		
IMEI Code:	Conducted: 352510090003668 Radiated: 352510090003445		
SIM Information:	Support One SIM Card		
Power supply:	DC 3.8V		
Adapter information:	Input:100-240Va.c.,50/60Hz,0.5A Output: 5Vd.c.,2.0A		
Hardware version:	V0.3		
Software version:	R1.09		
4G			
Operation Band:	<input checked="" type="checkbox"/> FDD Band 2 <input type="checkbox"/> FDD Band 7	<input checked="" type="checkbox"/> FDD Band 4 <input type="checkbox"/> FDD Band 12	<input checked="" type="checkbox"/> FDD Band 5 <input checked="" type="checkbox"/> FDD Band 13
Transmit frequency:	FDD Band 2: FDD Band 4: FDD Band 5: FDD Band 13:	1850.7 MHz – 1909.3 MHz 1710.7 MHz – 1754.3 MHz 824.7 MHz – 848.3 MHz 779.5 MHz – 784.5 MHz	
Receive frequency:	FDD Band 2: FDD Band 4: FDD Band 5: FDD Band 13:	1930.7 MHz – 1989.3 MHz 2110.7 MHz – 2154.3 MHz 869.7 MHz – 893.3 MHz 748.5 MHz – 753.5 MHz	
Channel bandwidth:	FDD Band 2: FDD Band 4: FDD Band 5: FDD Band 13:	1.4MHz, 3MHz, 5MHz, 10MHz, 15MHz, 20MHz 1.4MHz, 3MHz, 5MHz, 10MHz, 15MHz, 20MHz 1.4MHz, 3MHz, 5MHz, 10MHz 5MHz, 10MHz	
Power Class:	Class 3		
Modulation type:	QPSK, 16QAM		

Antenna type	Internal Antenna
Antenna Gain	Band2:-3.0dBi Band4: -3.0dBi Band5: -3.0dBi Band13: -3.0dBi

3.3. Operation state

➤ Test frequency list

FDD Band 2		Test Frequency ID	Bandwidth [MHz]	N _{UL}	Frequency of Uplink [MHz]	N _{DL}	Frequency of Downlink [MHz]	
	Low Range	1.4		18607	1850.7	607	1930.7	
		3		18615	1851.5	615	1931.5	
		5		18625	1852.5	625	1932.5	
		10		18650	1855	650	1935	
		15 ^[1]		18675	1857.5	675	1937.5	
		20 ^[1]		18700	1860	700	1940	
	Mid Range	1.4/3/5/10/15 ^[1] /20 ^[1]		18900	1880	900	1960	
	High Range	1.4		19193	1909.3	1193	1989.3	
		3		19185	1908.5	1185	1988.5	
		5		19175	1907.5	1175	1987.5	
		10		19150	1905	1150	1985	
		15 ^[1]		19125	1902.5	1125	1982.5	
		20 ^[1]		19100	1900	1100	1980	
	NOTE 1: Bandwidth for which a relaxation of the specified UE receiver sensitivity requirement (TS 36.101 [27] Clause 7.3) is allowed.							

FDD Band 4		Test Frequency ID	Bandwidth [MHz]	N _{UL}	Frequency of Uplink [MHz]	N _{DL}	Frequency of Downlink [MHz]
	Low Range	1.4		19957	1710.7	1957	2110.7
		3		19965	1711.5	1965	2111.5
		5		19975	1712.5	1975	2112.5
		10		20000	1715	2000	2115
		15		20025	1717.5	2025	2117.5
		20		20050	1720	2050	2120
	Mid Range	1.4/3/5/10/15/20		20175	1732.5	2175	2132.5
	High Range	1.4		20393	1754.3	2393	2154.3
		3		20385	1753.5	2385	2153.5
		5		20375	1752.5	2375	2152.5
		10		20350	1750	2350	2150
		15		20325	1747.5	2325	2147.5
		20		20300	1745	2300	2145

FDD Band 5		Test Frequency ID	Bandwidth [MHz]	N _{UL}	Frequency of Uplink [MHz]	N _{DL}	Frequency of Downlink [MHz]	
	Low Range	1.4		20407	824.7	2407	869.7	
		3		20415	825.5	2415	870.5	
		5		20425	826.5	2425	871.5	
		10 ^[1]		20450	829	2450	874	
		Mid Range	1.4/3/5/10 ^[1]		20525	836.5	2525	881.5
	High Range	1.4		20643	848.3	2643	893.3	
		3		20635	847.5	2635	892.5	
		5		20625	846.5	2625	891.5	
		10 ^[1]		20600	844	2600	889	
		NOTE 1: Bandwidth for which a relaxation of the specified UE receiver sensitivity requirement (TS 36.101 [27] Clause 7.3) is allowed.						

FDD Band 13		Test Frequency ID	Bandwidth [MHz]	N _{UL}	Frequency of Uplink [MHz]	N _{DL}	Frequency of Downlink [MHz]
	Low Range	5 ^[1]		23205	779.5	5205	748.5
		10 ^[1]		23230	782	5230	751
	Mid Range	5 ^[1] /10 ^[1]		23230	782	5230	751
	High Range	5 ^[1]		23255	784.5	5255	753.5
		10 ^[1]		23230	782	5230	751
	NOTE 1: Bandwidth for which a relaxation of the specified UE receiver sensitivity requirement (TS 36.101 [27] Clause 7.3) is allowed.						

3.4. EUT operation mode

For RF test items

The EUT has been tested under typical operating condition. Testing was performed by configuring EUT to maximum output power status.

Test Items	Band	Bandwidth (MHz)						Modulation		RB #		
		1.4	3	5	10	15	20	QPSK	16QAM	1	Half	Full
Conducted Output Power	2	o	o	o	o	o	o	o	o	o	o	o
	4	o	o	o	o	o	o	o	o	o	o	o
	5	o	o	o	o	-	-	o	o	o	o	o
	7	-	-	o	o	o	o	o	o	o	o	o
	13	-	-	o	o	-	-	o	o	o	o	o
Peak-to-Average Ratio	2	o	o	o	o	o	o	o	o	o	-	o
	4	o	o	o	o	o	o	o	o	o	-	o
	5	o	o	o	o	-	-	o	o	o	-	o
	7	-	-	o	o	o	o	o	o	o	-	o
	13	-	-	o	o	-	-	o	o	o	-	o
99% Occupied Bandwidth & 26 dB Bandwidth	2	o	o	o	o	o	o	o	o	-	-	o
	4	o	o	o	o	o	o	o	o	-	-	o
	5	o	o	o	o	-	-	o	o	-	-	o
	7	-	-	o	o	o	o	o	o	-	-	o
	13	-	-	o	o	-	-	o	o	-	-	o
Band Edge	2	o	o	o	o	o	o	o	o	o	-	o
	4	o	o	o	o	o	o	o	o	o	-	o
	5	o	o	o	o	-	-	o	o	o	-	o
	7	-	-	o	o	o	o	o	o	o	-	o
	13	-	-	o	o	-	-	o	o	o	-	o
Conducted Spurious Emission	2	o	o	o	o	o	o	o	o	o	-	-
	4	o	o	o	o	o	o	o	o	o	-	-
	5	o	o	o	o	-	-	o	o	o	-	-
	7	-	-	o	o	o	o	o	o	o	-	-
	13	-	-	o	o	-	-	o	o	o	-	-
Frequency Stability	2	o	o	o	o	o	o	o	o	-	-	o
	4	o	o	o	o	o	o	o	o	-	-	o
	5	o	o	o	o	-	-	o	o	-	-	o
	7	-	-	o	o	o	o	o	o	-	-	o
	13	-	-	o	o	-	-	o	o	-	-	o
ERP and EIRP	2	o	o	o	o	o	o	o	o	o	-	-
	4	o	o	o	o	o	o	o	o	o	-	-
	5	o	o	o	o	-	-	o	o	o	-	-
	7	-	-	o	o	o	o	o	o	o	-	-
	13	-	-	o	o	-	-	o	o	o	-	-
Radiated Spurious Emission	2	o	o	o	o	o	o	o	-	o	-	-
	4	o	o	o	o	o	o	o	-	o	-	-
	5	o	o	o	o	-	-	o	-	o	-	-
	7	-	-	o	o	o	o	o	-	o	-	-
	13	-	-	o	o	-	-	o	-	o	-	-
Remark	<ol style="list-style-type: none"> The mark "o" means that this configuration is chosen for testing The mark "-" means that this bandwidth is not test. The device is investigated from 30MHz to 10 times of fundamental signal for radiated spurious emission test under different RB size/offset and modulations in exploratory test. Subsequently, only the worst case emissions are reported. 											

3.5. EUT configuration

The following peripheral devices and interface cables were connected during the measurement:

- - supplied by the manufacturer
- - supplied by the lab

○ /	Manufacturer:	/
	Model No.:	/
○ /	Manufacturer:	/
	Model No.:	/

3.6. Modifications

No modifications were implemented to meet testing criteria.

4. TEST ENVIRONMENT

4.1. Address of the test laboratory

Laboratory: Shenzhen Huatongwei International Inspection Co., Ltd.

Address: 1/F, Bldg 3, Hongfa Hi-tech Industrial Park, Genyu Road, Tianliao, Gongming, Shenzhen, China

4.2. Test Facility

CNAS-Lab Code: L1225

Shenzhen Huatongwei International Inspection Co., Ltd. has been assessed and proved to be in compliance with CNAS-CL01 Accreditation Criteria for Testing and Calibration Laboratories (identical to ISO/IEC17025: 2005 General Requirements) for the Competence of Testing and Calibration Laboratories.

A2LA-Lab Cert. No.: 3902.01

Shenzhen Huatongwei International Inspection Co., Ltd. EMC Laboratory has been accredited by A2LA for technical competence in the field of electrical testing, and proved to be in compliance with ISO/IEC 17025: 2005 General Requirements for the Competence of Testing and Calibration Laboratories and any additional program requirements in the identified field of testing.

FCC-Registration No.: 762235

Shenzhen Huatongwei International Inspection Co., Ltd. EMC Laboratory has been registered and fully described in a report filed with the FCC (Federal Communications Commission). The acceptance letter from the FCC is maintained in our files.

IC-Registration No.:5377B-1

Two 3m Alternate Test Site of Shenzhen Huatongwei International Inspection Co., Ltd. has been registered by Certification and Engineering Bureau of Industry Canada for the performance of radiated measurements with Registration No.: 5377B-1.

ACA

Shenzhen Huatongwei International Inspection Co., Ltd. EMC Laboratory can also perform testing for the Australian C-Tick mark as a result of our A2LA accreditation.

4.3. Equipments Used during the Test

RF Conducted Test						
Item	Equipment	Manufacturer	Model No.	Serial No.	Last Cal. (mm-dd-yy)	Next Cal. (mm-dd-yy)
1	Wide Radio communication tester	Rohde&Schwarz	CMW500	137688	10/26/2017	10/25/2018
2	Spectrum Analyzer	Rohde&Schwarz	FSW26	103440	11/11/2017	11/10/2018
3	MXA Signal Analyzer	Agilent	N9020A	MY5050187	11/10/2017	11/09/2018
4	Splitter	Mini-Circuit	ZAPD-4	400059	03/20/2017	03/19/2018
5	Climate Chamber	ESPEC	EL-10KA	05107008	11/10/2017	11/09/2018

Radiated Emissions						
Item	Equipment	Manufacturer	Model No.	Serial No.	Last Cal. (mm-dd-yy)	Next Cal. (mm-dd-yy)
1	EMI Test Receiver	R&S	ESCI	101247	11/11/2017	11/10/2018
2	Loop Antenna	R&S	HFH2-Z2	100020	11/20/2017	11/19/2018
3	Ultra-Broadband Antenna	SCHWARZBECK	VULB9163	538	4/5/2017	4/4/2020
4	Preamplifier	SCHWARZBECK	BBV 9743	9743-0022	10/18/2017	10/17/2018
5	RF Connection Cable	HUBER+SUHNER	RE-7-FL	N/A	11/21/2017	11/20/2018
6	EMI Test Software	R&S	ESK1	N/A	N/A	N/A
7	Spectrum Analyzer	R&S	FSP40	100597	11/11/2017	11/10/2018
8	Horn Antenna	SCHWARZBECK	9120D	1011	3/27/2017	3/26/2020
9	Horn Antenna	SCHWARZBECK	BBHA9170	25841	3/27/2017	3/26/2018
10	Broadband Preamplifier	SCHWARZBECK	BBV 9718	9718-248	10/18/2017	10/17/2018
11	High pass filter	Compliance Direction systems	BSU-6	34202	11/11/2017	11/10/2018
12	RF Connection Cable	HUBER+SUHNER	RE-7-FH	N/A	11/21/2017	11/20/2018
13	Signal Generator	Rohde&Schwarz	SMB100A	114360	06/13/2017	06/12/2018
14	Wide Radio communication tester	Rohde&Schwarz	CMW500	137688	10/26/2017	10/25/2018
15	EMI Test Software	Audix	E3	N/A	N/A	N/A
16	Turntable	MATURO	TT2.0	N/A	N/A	N/A
17	Antenna Mast	MATURO	TAM-4.0-P	N/A	N/A	N/A

4.4. Environmental conditions

During the measurement the environmental conditions were within the listed ranges:

Voltage	VN=Nominal Voltage	DC 3.80V
	VL=Lower Voltage	DC 3.60V
	VH=Higher Voltage	DC 4.35V
Temperature	TN=Normal Temperature	25 °C
	Extreme Temperature	From -30° to + 50° centigrade
Humidity	30~60 %	
Air Pressure	950-1050 hPa	

4.5. Statement of the measurement uncertainty

The data and results referenced in this document are true and accurate. The reader is cautioned that there may be errors within the calibration limits of the equipment and facilities. The measurement uncertainty was calculated for all measurements listed in this test report acc. to TR-100028-01 "Electromagnetic compatibility and Radio spectrum Matters (ERM); Uncertainties in the measurement of mobile radio equipment characteristics; Part 1" and TR-100028-02 "Electromagnetic compatibility and Radio spectrum Matters (ERM); Uncertainties in the measurement of mobile radio equipment characteristics; Part 2" and is documented in the Shenzhen Huatongwei International Inspection Co., Ltd quality system acc. to DIN EN ISO/IEC 17025. Furthermore, component and process variability of devices similar to that tested may result in additional deviation. The manufacturer has the sole responsibility of continued compliance of the device.

Hereafter the best measurement capability for Shenzhen Huatongwei laboratory is reported:

Test Items	Measurement Uncertainty	Notes
Frequency stability	25 Hz	(1)
Transmitter power conducted	0.57 dB	(1)
Transmitter power Radiated	2.20 dB	(1)
Conducted spurious emission 9KHz-12.75 GHz	1.60 dB	(1)
Conducted Emission 9KHz-30MHz	3.39 dB	(1)
Radiated Emission 30~1000MHz	4.24 dB	(1)
Radiated Emission 1~18GHz	5.16 dB	(1)
Radiated Emission 18-40GHz	5.54 dB	(1)
Occupied Bandwidth	-----	(1)
Emission Mask	-----	(1)
Modulation Characteristic	-----	(1)
Transmitter Frequency Behavior	-----	(1)

(1) This uncertainty represents an expanded uncertainty expressed at approximately the 95% confidence level using a coverage factor of $k=1.96$.

5. TEST CONDITIONS AND RESULTS

5.1. Conducted Output Power

LIMIT

N/A

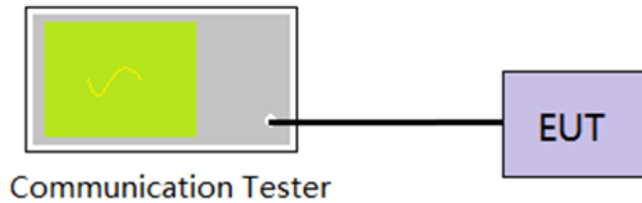
TEST CONFIGURATION**TEST PROCEDURE**

1. The EUT output port was connected to communication tester.
2. Set EUT at maximum power through communication tester.
3. Select lowest, middle, and highest channels for each band and different modulation.
4. Measure the maximum burst average power.

TEST MODE:

Please refer to the clause 3.3

TEST RESULTS **Passed** **Not Applicable**

Refer to appendix A on the section 8 appendix report

5.2. Peak-to-Average Ratio

LIMIT

13dB

TEST CONFIGURATION

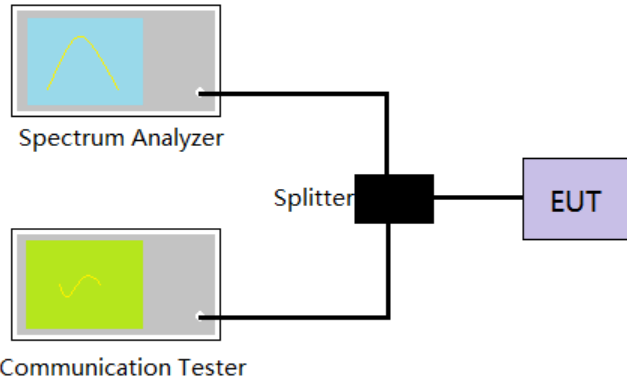

TEST PROCEDURE

1. The EUT was connected to the spectrum analyzer and communication tester via a power splitter
2. Set EUT in maximum power output.
3. Center Frequency = Carrier frequency, RBW > Emission bandwidth of signal
4. The signal analyzer was set to collect one million samples to generate the CCDF curve
5. The measurement interval was set depending on the type of signal analyzed.
 - i. For continuous signals (>98% duty cycle), the measurement interval was set to 1ms.
 - ii. For burst transmissions, the spectrum analyzer is set to use an internal "RF Burst" trigger that is synced with an incoming pulse and the measurement interval is set to less than the duration of the "on time" of one burst to ensure that energy is only captured during a time in which the transmitter is operating at maximum power
6. Record the maximum PAPR level associated with a probability of 0.1%.

TEST MODE:

Please refer to the clause 3.3

TEST RESULTS

Passed Not Applicable

Refer to appendix B on the section 8 appendix report

5.3. 99% Occupied Bandwidth & 26 dB Bandwidth

LIMIT

N/A

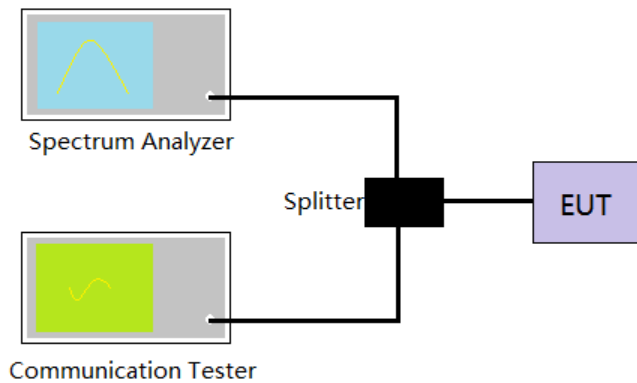
TEST CONFIGURATION**TEST PROCEDURE**

1. The EUT was connected to the spectrum analyzer and communication tester via a power splitter
2. Set EUT in maximum power output.
3. Spectrum analyzer setting as follow:
Center Frequency= Carrier frequency, RBW=1% to 5% of the anticipated OBW, VBW= 3 * RBW,
Detector=Peak,
Trace maximum hold.
4. Record the value of 99% Occupied bandwidth and 26dB bandwidth.

TEST MODE:

Please refer to the clause 3.3

TEST RESULTS **Passed** **Not Applicable**

Refer to appendix C on the section 8 appendix report

5.4. Band Edge

LIMIT

Part 24.238 and Part 22.917 and Part 27.53 specify that the power of any emission outside of the authorized operating frequency ranges must be attenuated below the transmitting power (P) by a factor of at least $43 + 10 \log(P)$ dB.

The specification that emissions shall be attenuated below the transmitter power (P) by at least $43 + 10 \log(P)$ dB, translates in the relevant power range (1 to 0.001 W) to -13 dBm. At 1 W the specified minimum attenuation becomes 43 dB and relative to a 30 dBm (1 W) carrier becomes a limit of -13 dBm. At 0.001 W (0 dBm) the minimum attenuation is 13 dB, which again yields a limit of -13 dBm. In this way a translation of the specification from relative to absolute terms is carried out.

TEST CONFIGURATION

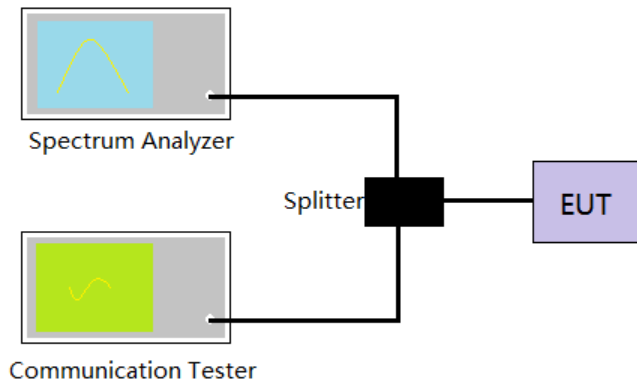

TEST PROCEDURE

1. The EUT was connected to the spectrum analyzer and communication tester via a power splitter
2. Set EUT in maximum power output.
3. The band edges of low and high channels were measured.
4. Spectrum analyzer setting as follow:
RBW= no less than 1% of the OBW, VBW =3 * RBW, Sweep time= Auto
5. Record the test plot.

TEST MODE:

Please refer to the clause 3.3

TEST RESULTS

Passed Not Applicable

Refer to appendix D on the section 8 appendix report

5.5. Conducted Spurious Emissions

LIMIT

Part 24.238 and Part 22.917 and Part 27.53 specify that the power of any emission outside of the authorized operating frequency ranges must be attenuated below the transmitting power (P) by a factor of at least $43 + 10 \log(P)$ dB.

The specification that emissions shall be attenuated below the transmitter power (P) by at least $43 + 10 \log(P)$ dB, translates in the relevant power range (1 to 0.001 W) to -13 dBm. At 1 W the specified minimum attenuation becomes 43 dB and relative to a 30 dBm (1 W) carrier becomes a limit of -13 dBm. At 0.001 W (0 dBm) the minimum attenuation is 13 dB, which again yields a limit of -13 dBm. In this way a translation of the specification from relative to absolute terms is carried out.

LTE Band 13

Part 27.53(f) For operations in the 746-758 MHz, 775-788 MHz, and 805-806 MHz bands, emissions in the band 1559-1610 MHz shall be limited to -70 dBW/MHz equivalent isotropically radiated power (EIRP) for wideband signals, and -80 dBW EIRP for discrete emissions of less than 700 Hz bandwidth. For the purpose of equipment authorization, a transmitter shall be tested with an antenna that is representative of the type that will be used with the equipment in normal operation.

TEST CONFIGURATION

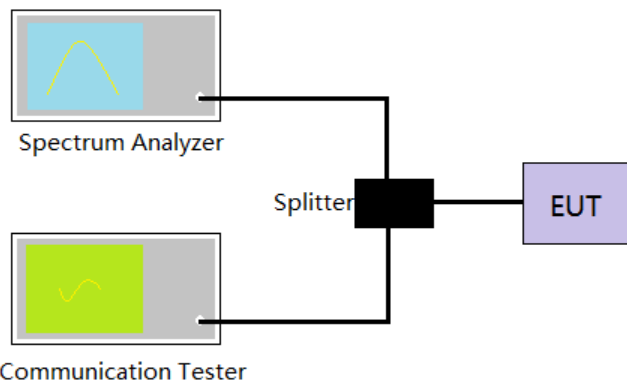

TEST PROCEDURE

1. The EUT was connected to the spectrum analyzer and communication tester via a power splitter
2. Set EUT in maximum power output.
3. Spectrum analyzer setting as follow:
 - Below 1GHz, RBW=100KHz, VBW = 300KHz, Detector=Peak, Sweep time= Auto
 - Above 1GHz, RBW=1MHz, VBW=3MHz, Detector=Peak, Sweep time= Auto
 - Scan frequency range up to 10th harmonic.
4. Record the test plot.

TEST MODE:

Please refer to the clause 3.3

TEST RESULTS

Passed **Not Applicable**

Refer to appendix E on the section 8 appendix report

5.6. Frequency stability VS Temperature measurement

LIMIT

2.5ppm

TEST CONFIGURATION

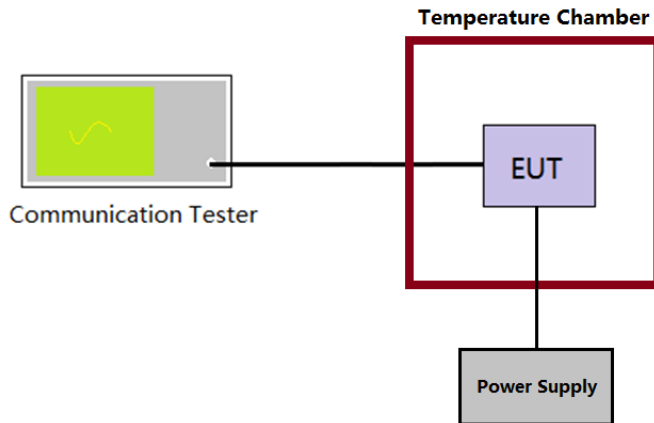

TEST PROCEDURE

1. The equipment under test was connected to an external DC power supply and input rated voltage.
2. The EUT output port was connected to communication tester.
3. The EUT was placed inside the temperature chamber.
4. Turn EUT off and set the chamber temperature to -30°C . After the temperature stabilized for approximately 30 minutes recorded the frequency.
5. Repeat step 4 measure with 10°C increased per stage until the highest temperature of $+50^{\circ}\text{C}$ reached.

TEST MODE:

Please refer to the clause 3.3

TEST RESULTS

Passed Not Applicable

Refer to appendix F on the section 8 appendix report

5.7. Frequency stability VS Voltage measurement

LIMIT

2.5ppm

TEST CONFIGURATION

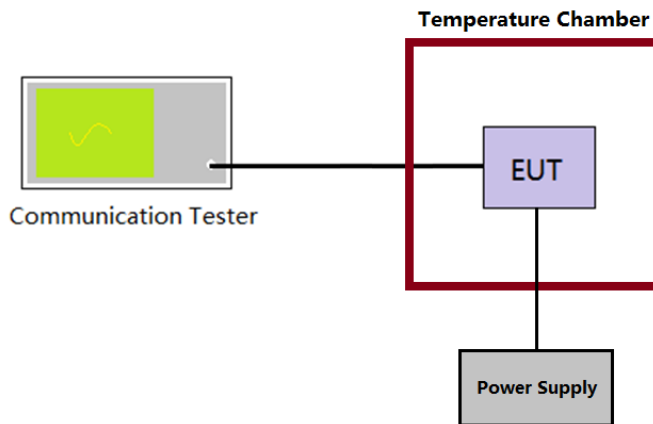

TEST PROCEDURE

1. The equipment under test was connected to an external DC power supply and input rated voltage.
2. The EUT output port was connected to communication tester.
3. The EUT was placed inside the temperature chamber at 25°C
4. The power supply voltage to the EUT was varied $\pm 15\%$ of the nominal value measured at the input to the EUT
5. Record the maximum frequency change.

TEST MODE:

Please refer to the clause 3.3

TEST RESULTS

Passed Not Applicable

Refer to appendix F on the section 8 appendix report

5.8. ERP and EIRP

LIMIT

LTE Band 2: 2W(33dBm) EIRP

LTE Band 4: 1W(30dBm) EIRP

LTE Band 5: 7W(38.50dBm) ERP

LTE Band 13: 30W(44.77dBm) ERP

TEST CONFIGURATION

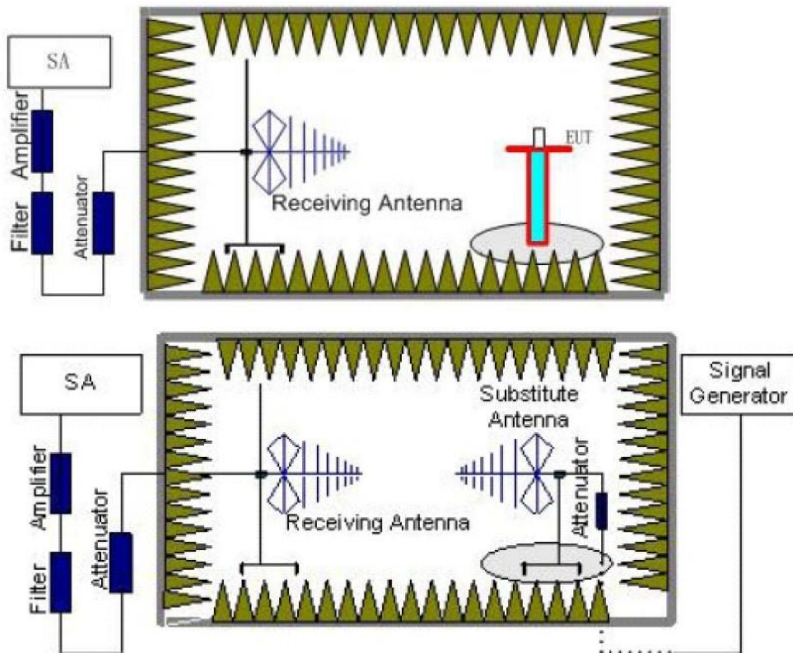

TEST PROCEDURE

1. EUT was placed on a 0.8 meter for below 1GHz and 1.5 meter for above 1GHz high non-conductive stand at a 3 meter test distance from the receive antenna. A receiving antenna was placed on the antenna mast 3 meters from the EUT for emission measurements. The height of receiving antenna is 1.0m. Detected emissions were maximized at each frequency by rotating the EUT through 360° and adjusting the receiving antenna polarization. The radiated emission measurements of all transmit frequencies in three channels (High, Middle, Low) were measured with peak detector.
2. A log-periodic antenna or double-ridged waveguide horn antenna shall be substituted in place of the EUT. The log-periodic antenna will be driven by a signal generator and the level will be adjusted till the same power value on the spectrum analyzer or receiver. The level of the spurious emissions can be calculated through the level of the signal generator, cable loss, the gain of the substitution antenna and the reading of the spectrum analyzer or receiver.
3. The EUT is then put into continuously transmitting mode at its maximum power level during the test. Set Test Receiver or Spectrum RBW=1MHz, VBW=3MHz for above 1GHz and RBW=100kHz, VBW=300kHz for 30MHz to 1GHz, And the maximum value of the receiver should be recorded as (Pr).
4. The EUT shall be replaced by a substitution antenna. In the chamber, an substitution antenna for the frequency band of interest is placed at the reference point of the chamber. An RF Signal source for the frequency band of interest is connected to the substitution antenna with a cable that has been constructed to not interfere with the radiation pattern of the antenna. A power (P_{Mea}) is applied to the input of the substitution antenna, and adjust the level of the signal generator output until the value of the receiver reach the previously recorded (Pr). The power of signal source (P_{Mea}) is recorded. The test should be performed by rotating the test item and adjusting the receiving antenna polarization.
5. A amplifier should be connected to the Signal Source output port. And the cable should be connect between the Amplifier and the Substitution Antenna. The cable loss (P_{cl}), the Substitution Antenna Gain (G_a) and the Amplifier Gain (P_{Ag}) should be recorded after test.

6. The measurement results are obtained as described below:
Power(EIRP)=PMea- PAg - Pcl + Ga
We used SMF100A microwave signal generator which signal level can up to 33dBm,so we not used power Amplifier for substitution test; The measurement results are amend as described below:
Power(EIRP)=PMea- Pcl + Ga
7. This value is EIRP since the measurement is calibrated using an antenna of known gain (2.15 dBi) and known input power.
ERP can be calculated from EIRP by subtracting the gain of the dipole, ERP = EIRP-2.15dBi.

TEST MODE:

Please refer to the clause 3.3

TEST RESULTS

Passed Not Applicable

LTE Band 2-1.4MHz						
Modulation	Channel	EIRP (dBm)		Limit (dBm)	Result	
		Vertical	Horizontal			
QPSK	Low	20.48	18.15	≤33.00	PASS	
	Mid	20.55	18.18			
	High	20.86	17.97			
16QAM	Low	19.56	17.26		≤33.00	PASS
	Mid	19.77	17.48			
	High	19.72	17.38			

LTE Band 2-3MHz						
Modulation	Channel	EIRP (dBm)		Limit (dBm)	Result	
		Vertical	Horizontal			
QPSK	Low	20.83	17.97	≤33.00	PASS	
	Mid	21.30	18.16			
	High	21.13	17.93			
16QAM	Low	19.30	17.42		≤33.00	PASS
	Mid	19.62	17.58			
	High	19.58	17.34			

LTE Band 2-5MHz						
Modulation	Channel	EIRP (dBm)		Limit (dBm)	Result	
		Vertical	Horizontal			
QPSK	Low	20.89	18.12	≤33.00	PASS	
	Mid	20.61	17.99			
	High	20.62	17.60			
16QAM	Low	19.92	17.73		≤33.00	PASS
	Mid	19.81	17.56			
	High	19.64	17.11			

LTE Band 2-10MHz						
Modulation	Channel	EIRP (dBm)		Limit (dBm)	Result	
		Vertical	Horizontal			
QPSK	Low	20.83	17.94	≤33.00	PASS	
	Mid	20.96	17.82			
	High	20.71	17.62			
16QAM	Low	19.82	17.47		≤33.00	PASS
	Mid	19.87	17.31			
	High	19.71	17.23			

LTE Band 2-15MHz						
Modulation	Channel	EIRP (dBm)		Limit (dBm)	Result	
		Vertical	Horizontal			
QPSK	Low	20.18	18.30	≤33.00	PASS	
	Mid	19.53	18.42			
	High	19.83	17.69			
16QAM	Low	19.07	17.59		≤33.00	PASS
	Mid	18.48	18.99			
	High	18.57	17.16			

LTE Band 2-20MHz						
Modulation	Channel	EIRP (dBm)		Limit (dBm)	Result	
		Vertical	Horizontal			
QPSK	Low	20.26	17.85	≤33.00	PASS	
	Mid	19.98	18.09			
	High	19.95	17.71			
16QAM	Low	18.95	17.56		≤33.00	PASS
	Mid	18.97	17.87			
	High	19.02	17.51			

LTE Band 4-1.4MHz					
Modulation	Channel	EIRP (dBm)		Limit (dBm)	Result
		Vertical	Horizontal		
QPSK	Low	21.93	19.87	≤30.00	PASS
	Mid	22.10	19.81		
	High	22.34	19.69		
16QAM	Low	20.55	19.32		PASS
	Mid	20.74	19.19		
	High	20.62	19.31		

LTE Band 4-3MHz					
Modulation	Channel	EIRP (dBm)		Limit (dBm)	Result
		Vertical	Horizontal		
QPSK	Low	21.54	19.25	≤30.00	PASS
	Mid	21.38	19.47		
	High	21.06	19.36		
16QAM	Low	20.81	19.10		PASS
	Mid	20.30	19.19		
	High	21.40	19.59		

LTE Band 4-5MHz					
Modulation	Channel	EIRP (dBm)		Limit (dBm)	Result
		Vertical	Horizontal		
QPSK	Low	21.78	20.35	≤30.00	PASS
	Mid	21.98	19.60		
	High	21.90	19.65		
16QAM	Low	20.68	19.68		PASS
	Mid	20.91	18.96		
	High	20.43	19.12		

LTE Band 4-10MHz					
Modulation	Channel	EIRP (dBm)		Limit (dBm)	Result
		Vertical	Horizontal		
QPSK	Low	22.07	20.23	≤30.00	PASS
	Mid	21.96	19.51		
	High	21.40	19.72		
16QAM	Low	21.14	19.63		PASS
	Mid	21.34	18.87		
	High	20.76	19.10		

LTE Band 4-15MHz						
Modulation	Channel	EIRP (dBm)		Limit (dBm)	Result	
		Vertical	Horizontal			
QPSK	Low	20.96	18.30	≤30.00	PASS	
	Mid	20.79	18.54			
	High	21.17	18.65			
16QAM	Low	20.00	17.82		≤30.00	PASS
	Mid	19.97	17.96			
	High	20.13	18.23			

LTE Band 4-20MHz						
Modulation	Channel	EIRP (dBm)		Limit (dBm)	Result	
		Vertical	Horizontal			
QPSK	Low	21.12	18.33	≤30.00	PASS	
	Mid	21.37	18.73			
	High	21.42	18.80			
16QAM	Low	19.92	17.79		≤30.00	PASS
	Mid	19.58	18.04			
	High	19.77	18.24			

LTE Band 5-1.4MHz						
Modulation	Channel	ERP (dBm)		Limit (dBm)	Result	
		Vertical	Horizontal			
QPSK	Low	21.75	20.90	≤38.50	PASS	
	Mid	21.73	20.64			
	High	21.71	20.84			
16QAM	Low	20.90	19.81		≤38.50	PASS
	Mid	20.70	19.91			
	High	20.71	19.92			

LTE Band 5-3MHz						
Modulation	Channel	ERP (dBm)		Limit (dBm)	Result	
		Vertical	Horizontal			
QPSK	Low	22.01	20.38	≤38.50	PASS	
	Mid	22.21	20.48			
	High	22.10	20.54			
16QAM	Low	20.52	20.05		≤38.50	PASS
	Mid	20.44	19.85			
	High	20.47	19.89			

LTE Band 5-5MHz						
Modulation	Channel	ERP (dBm)		Limit (dBm)	Result	
		Vertical	Horizontal			
QPSK	Low	21.73	20.05	≤38.50	PASS	
	Mid	21.86	18.93			
	High	21.71	18.78			
16QAM	Low	21.25	19.79		≤38.50	PASS
	Mid	21.37	18.60			
	High	21.22	18.49			

LTE Band 5-10MHz						
Modulation	Channel	ERP (dBm)		Limit (dBm)	Result	
		Vertical	Horizontal			
QPSK	Low	21.62	20.02	≤38.50	PASS	
	Mid	21.75	18.96			
	High	21.52	18.82			
16QAM	Low	21.14	19.58		≤38.50	PASS
	Mid	21.29	18.60			
	High	21.13	18.45			

LTE Band 13-5MHz						
Modulation	Channel	ERP (dBm)		Limit (dBm)	Result	
		Vertical	Horizontal			
QPSK	Low	20.78	18.98	<44.77	PASS	
	Mid	21.04	19.00			
	High	21.50	18.98			
16QAM	Low	19.66	18.07		<44.77	PASS
	Mid	19.99	18.28			
	High	20.03	18.10			

LTE Band 13-10MHz					
Modulation	Channel	ERP (dBm)		Limit (dBm)	Result
		Vertical	Horizontal		
QPSK	Mid	21.74	18.89	<44.77	PASS
16QAM	Mid	20.26	18.31		PASS

5.9. Radiated Spurious Emission

LIMIT

LTE Band 2/4/5/13: -13dBm;

TEST CONFIGURATION

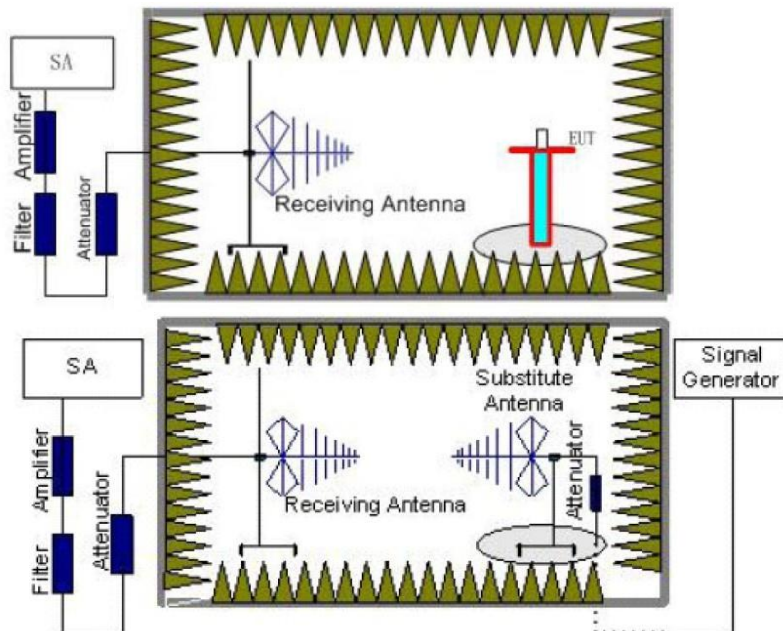

TEST RESULTS

1. EUT was placed on a 0.8 meter for below 1GHz and 1.5 meter for above 1GHz high non-conductive stand at a 3 meter test distance from the receive antenna. A receiving antenna was placed on the antenna mast 3 meters from the EUT for emission measurements. The height of receiving antenna is 1.0m. Detected emissions were maximized at each frequency by rotating the EUT through 360° and adjusting the receiving antenna polarization. The radiated emission measurements of all transmit frequencies in three channels (High, Middle, Low) were measured with peak detector.
2. A log-periodic antenna or double-ridged waveguide horn antenna shall be substituted in place of the EUT. The log-periodic antenna will be driven by a signal generator and the level will be adjusted till the same power value on the spectrum analyzer or receiver. The level of the spurious emissions can be calculated through the level of the signal generator, cable loss, the gain of the substitution antenna and the reading of the spectrum analyzer or receiver.
3. The EUT is then put into continuously transmitting mode at its maximum power level during the test. Set Test Receiver or Spectrum RBW=1MHz, VBW=3MHz for above 1GHz and RBW=100kHz, VBW=300kHz for 30MHz to 1GHz, And the maximum value of the receiver should be recorded as (Pr).
4. The EUT shall be replaced by a substitution antenna. In the chamber, an substitution antenna for the frequency band of interest is placed at the reference point of the chamber. An RF Signal source for the frequency band of interest is connected to the substitution antenna with a cable that has been constructed to not interfere with the radiation pattern of the antenna. A power (PMea) is applied to the input of the substitution antenna, and adjust the level of the signal generator output until the value of the receiver reach the previously recorded (Pr). The power of signal source (PMea) is recorded. The test should be performed by rotating the test item and adjusting the receiving antenna polarization.
5. A amplifier should be connected to the Signal Source output port. And the cable should be connect between the Amplifier and the Substitution Antenna. The cable loss (Pcl) ,the Substitution Antenna Gain (Ga) and the Amplifier Gain (PAg) should be recorded after test.

6. The measurement results are obtained as described below:
Power(EIRP)=PMea- PAg - Pcl + Ga
We used SMF100A microwave signal generator which signal level can up to 33dBm,so we not used power Amplifier for substitution test; The measurement results are amend as described below:
Power(EIRP)=PMea- Pcl + Ga
7. This value is EIRP since the measurement is calibrated using an antenna of known gain (2.15 dBi) and known input power.
ERP can be calculated from EIRP by subtracting the gain of the dipole, ERP = EIRP-2.15dBi.

TEST MODE:

Please refer to the clause 3.3

TEST RESULTS

Passed **Not Applicable**

LTE Band 2-1.4MHz					
Channel	Frequency (MHz)	Spurious Emission		Limit (dBm)	Result
		Polarization	Level (dBm)		
Low	3701.4	Vertical	-39.77	≤-13.00	Pass
	5552.1	V	-43.45		
	7402.8	V	---		
	3701.4	Horizontal	-38.75	≤-13.00	Pass
	5552.1	H	-45.85		
	7402.8	H	---		
Mid	3760	Vertical	-38.66	≤-13.00	Pass
	5640	V	-43.68		
	7520	V	---		
	3760	Horizontal	-38.51	≤-13.00	Pass
	5640	H	-45.61		
	7520	H	---		
High	3818.6	Vertical	-39.08	≤-13.00	Pass
	5727.9	V	-44.06		
	7637.2	V	---		
	3818.6	Horizontal	-38.60	≤-13.00	Pass
	5727.9	H	-45.53		
	7637.2	H	---		

LTE Band 2-3MHz					
Channel	Frequency (MHz)	Spurious Emission		Limit (dBm)	Result
		Polarization	Level (dBm)		
Low	3703	Vertical	-40.81	≤-13.00	Pass
	5554.5	V	-43.05		
	7406	V	---		
	3703	Horizontal	-42.63	≤-13.00	Pass
	5554.5	H	-42.67		
	7406	H	---		
Mid	3760	Vertical	-42.33	≤-13.00	Pass
	5640	V	-41.47		
	7520	V	---		
	3760	Horizontal	-42.12	≤-13.00	Pass
	5640	H	-40.68		
	7520	H	---		
High	3817	Vertical	-43.48	≤-13.00	Pass
	5725.5	V	-40.94		
	7634	V	---		
	3817	Horizontal	-42.02	≤-13.00	Pass
	5725.5	H	-40.63		
	7634	H	---		

LTE Band 2-5MHz					
Channel	Frequency (MHz)	Spurious Emission		Limit (dBm)	Result
		Polarization	Level (dBm)		
Low	3705	Vertical	-42.10	≤-13.00	Pass
	5557.5	V	-43.22		
	7410	V	---		
	3705	Horizontal	-41.31	≤-13.00	Pass
	5557.5	H	-43.39		
	7410	H	---		
Mid	3760	Vertical	-41.44	≤-13.00	Pass
	5640	V	-43.91		
	7520	V	---		
	3760	Horizontal	-40.91	≤-13.00	Pass
	5640	H	-43.30		
	7520	H	---		
High	3815	Vertical	-41.97	≤-13.00	Pass
	5722.5	V	-43.50		
	7630	V	---		
	3815	Horizontal	-42.53	≤-13.00	Pass
	5722.5	H	-43.62		
	7630	H	---		

LTE Band 2-10MHz					
Channel	Frequency (MHz)	Spurious Emission		Limit (dBm)	Result
		Polarization	Level (dBm)		
Low	3710	Vertical	-41.54	≤-13.00	Pass
	5565	V	-43.52		
	7420	V	---		
	3710	Horizontal	-40.19	≤-13.00	Pass
	5565	H	-43.80		
	7420	H	---		
Mid	3760	Vertical	-40.41	≤-13.00	Pass
	5640	V	-44.70		
	7520	V	---		
	3760	Horizontal	-39.52	≤-13.00	Pass
	5640	H	-43.81		
	7520	H	---		
High	3810	Vertical	-41.04	≤-13.00	Pass
	5715	V	-44.10		
	7620	V	---		
	3810	Horizontal	-40.28	≤-13.00	Pass
	5715	H	-43.95		
	7620	H	---		

LTE Band 2-15MHz					
Channel	Frequency (MHz)	Spurious Emission		Limit (dBm)	Result
		Polarization	Level (dBm)		
Low	3715	Vertical	-40.59	≤-13.00	Pass
	5572.5	V	-43.91		
	7430	V	---		
	3715	Horizontal	-38.81	≤-13.00	Pass
	5572.5	H	-44.28		
	7430	H	---		
Mid	3760	Vertical	-39.10	≤-13.00	Pass
	5640	V	-45.46		
	7520	V	---		
	3760	Horizontal	-37.92	≤-13.00	Pass
	5640	H	-44.44		
	7520	H	---		
High	3805	Vertical	-39.68	≤-13.00	Pass
	5707.5	V	-44.78		
	7610	V	---		
	3805	Horizontal	-39.93	≤-13.00	Pass
	5707.5	H	-44.83		
	7610	H	---		

LTE Band 2-20MHz					
Channel	Frequency (MHz)	Spurious Emission		Limit (dBm)	Result
		Polarization	Level (dBm)		
Low	3720	Vertical	-39.33	≤-13.00	Pass
	5580	V	-44.35		
	7440	V	---		
	3720	Horizontal	-37.32	≤-13.00	Pass
	5580	H	-44.77		
	7440	H	---		
Mid	3760	Vertical	-37.65	≤-13.00	Pass
	5640	V	-46.10		
	7520	V	---		
	3760	Horizontal	-36.32	≤-13.00	Pass
	5640	H	-45.21		
	7520	H	---		
High	3800	Vertical	-37.86	≤-13.00	Pass
	5700	V	-45.51		
	7600	V	---		
	3800	Horizontal	-39.27	≤-13.00	Pass
	5700	H	-45.80		
	7600	H	---		

Remark:

1. Remark"---" means that the emission level is too low to be measured
2. The emission levels of below 1 GHz are very lower than the limit and not show in test report.

LTE Band 4-1.4MHz					
Channel	Frequency (MHz)	Spurious Emission		Limit (dBm)	Result
		Polarization	Level (dBm)		
Low	3421.4	Vertical	-37.85	≤-13.00	Pass
	5132.1	V	-41.53		
	6842.8	V	---		
	3421.4	Horizontal	-38.86	≤-13.00	Pass
	5132.1	H	-44.57		
	6842.8	H	---		
Mid	3465	Vertical	-38.05	≤-13.00	Pass
	5197.5	V	-41.34		
	6930	V	---		
	3465	Horizontal	-38.61	≤-13.00	Pass
	5197.5	H	-44.37		
	6930	H	---		
High	3508.6	Vertical	-38.37	≤-13.00	Pass
	5262.9	V	-41.65		
	7017.2	V	---		
	3508.6	Horizontal	-38.67	≤-13.00	Pass
	5262.9	H	-44.43		
	7017.2	H	---		

LTE Band 4-3MHz					
Channel	Frequency (MHz)	Spurious Emission		Limit (dBm)	Result
		Polarization	Level (dBm)		
Low	3423	Vertical	-38.72	≤-13.00	Pass
	5134.5	V	-41.22		
	6846	V	---		
	3423	Horizontal	-38.31	≤-13.00	Pass
	5134.5	H	-44.28		
	6846	H	---		
Mid	3465	Vertical	-38.95	≤-13.00	Pass
	5197.5	V	-41.44		
	6930	V	---		
	3465	Horizontal	-38.11	≤-13.00	Pass
	5197.5	H	-44.44		
	6930	H	---		
High	3507	Vertical	-39.22	≤-13.00	Pass
	5260.5	V	-41.19		
	7014	V	---		
	3507	Horizontal	-37.85	≤-13.00	Pass
	5260.5	H	-44.68		
	7014	H	---		

LTE Band 4-5MHz					
Channel	Frequency (MHz)	Spurious Emission		Limit (dBm)	Result
		Polarization	Level (dBm)		
Low	3425	Vertical	-39.70	≤-13.00	Pass
	5137.5	V	-41.40		
	6850	V	---		
	3425	Horizontal	-38.03	≤-13.00	Pass
	5137.5	H	-44.85		
	6850	H	---		
Mid	3465	Vertical	-39.57	≤-13.00	Pass
	5197.5	V	-41.28		
	6930	V	-		
	3465	Horizontal	-38.18	≤-13.00	Pass
	5197.5	H	-44.97		
	6930	H	---		
High	3505	Vertical	-39.35	≤-13.00	Pass
	5257.5	V	-41.08		
	7010	V	-		
	3505	Horizontal	-38.30	≤-13.00	Pass
	5257.5	H	-45.09		
	7010	H	---		

LTE Band 4-10MHz					
Channel	Frequency (MHz)	Spurious Emission		Limit (dBm)	Result
		Polarization	Level (dBm)		
Low	3430	Vertical	-39.14	≤-13.00	Pass
	5145	V	-41.70		
	6860	V	---		
	3430	Horizontal	-37.88	≤-13.00	Pass
	5145	H	-44.73		
	6860	H	---		
Mid	3465	Vertical	-39.36	≤-13.00	Pass
	5197.5	V	-41.91		
	6930	V	---		
	3465	Horizontal	-37.67	≤-13.00	Pass
	5197.5	H	-44.56		
	6930	H	-		
High	3500	Vertical	-39.67	≤-13.00	Pass
	5250	V	-42.18		
	7000	V	-		
	3500	Horizontal	-37.50	≤-13.00	Pass
	5250	H	-44.40		
	7000	H	---		

LTE Band 4-15MHz					
Channel	Frequency (MHz)	Spurious Emission		Limit (dBm)	Result
		Polarization	Level (dBm)		
Low	3435	Vertical	-38.19	≤-13.00	Pass
	5152.5	V	-42.09		
	6870	V	---		
	3435	Horizontal	-37.89	≤-13.00	Pass
	5152.5	H	-44.03		
	6870	H	---		
Mid	3465	Vertical	-38.48	≤-13.00	Pass
	5197.5	V	-42.36		
	6930	V	---		
	3465	Horizontal	-38.14	≤-13.00	Pass
	5197.5	H	-44.23		
	6930	H	---		
High	3495	Vertical	-38.14	≤-13.00	Pass
	5242.5	V	-42.05		
	6990	V	---		
	3495	Horizontal	-38.08	≤-13.00	Pass
	5242.5	H	-44.18		
	6990	H	---		

LTE Band 4-20MHz					
Channel	Frequency (MHz)	Spurious Emission		Limit (dBm)	Result
		Polarization	Level (dBm)		
Low	3440	Vertical	-36.93	≤-13.00	Pass
	5160	V	-42.49		
	6880	V	---		
	3440	Horizontal	-37.66	≤-13.00	Pass
	5160	H	-44.53		
	6880	H	---		
Mid	3465	Vertical	-36.62	≤-13.00	Pass
	5197.5	V	-42.76		
	6930	V	---		
	3465	Horizontal	-37.93	≤-13.00	Pass
	5197.5	H	-44.31		
	6930	H	---		
High	3490	Vertical	-36.24	≤-13.00	Pass
	5235	V	-44.19		
	6980	V	---		
	3490	Horizontal	-37.35	≤-13.00	Pass
	5235	H	-44.24		
	6980	H	---		

Remark:

1. Remark"---" means that the emission level is too low to be measured
2. The emission levels of below 1 GHz are very lower than the limit and not show in test report.

LTE Band 5-1.4MHz					
Channel	Frequency (MHz)	Spurious Emission		Limit (dBm)	Result
		Polarization	Level (dBm)		
Low	1649.4	Vertical	-38.38	≤-13.00	Pass
	2474.1	V	-43.72		
	3298.8	V	---		
	1649.4	Horizontal	-40.79	≤-13.00	Pass
	2474.1	H	-45.63		
	3298.8	H	---		
Mid	1673	Vertical	-38.64	≤-13.00	Pass
	2509.5	V	-43.96		
	3346	V	---		
	1673	Horizontal	-41.06	≤-13.00	Pass
	2509.5	H	-45.85		
	3346	H	---		
High	1696.6	Vertical	-38.27	≤-13.00	Pass
	2544.9	V	-43.62		
	3393.2	V	-		
	1696.6	Horizontal	-41.18	≤-13.00	Pass
	2544.9	H	-45.96		
	3393.2	H	---		

LTE Band 5-3MHz					
Channel	Frequency (MHz)	Spurious Emission		Limit (dBm)	Result
		Polarization	Level (dBm)		
Low	1651	Vertical	-38.53	≤-13.00	Pass
	2476.5	V	-43.57		
	3302	V	---		
	1651	Horizontal	-41.42	≤-13.00	Pass
	2476.5	H	-45.77		
	3302	H	---		
Mid	1673	Vertical	-39.03	≤-13.00	Pass
	2509.5	V	-44.02		
	3346	V	---		
	1673	Horizontal	-41.13	≤-13.00	Pass
	2509.5	H	-46.01		
	3346	H	---		
High	1695	Vertical	-40.08	≤-13.00	Pass
	2542.5	V	-45.74		
	3390	V	---		
	1695	Horizontal	-42.85	≤-13.00	Pass
	2542.5	H	-47.65		
	3390	H	---		

LTE Band 5-5MHz					
Channel	Frequency (MHz)	Spurious Emission		Limit (dBm)	Result
		Polarization	Level (dBm)		
Low	1653	Vertical	-38.65	≤-13.00	Pass
	2479.5	V	-43.45		
	3306	V	---		
	1653	Horizontal	-41.95	≤-13.00	Pass
	2479.5	H	-45.88		
	3306	H	---		
Mid	1673	Vertical	-39.07	≤-13.00	Pass
	2509.5	V	-43.82		
	3346	V	---		
	1673	Horizontal	-41.75	≤-13.00	Pass
	2509.5	H	-44.51		
	3346	H	---		
High	1693	Vertical	-39.76	≤-13.00	Pass
	2539.5	V	-44.96		
	3386	V	---		
	1693	Horizontal	-42.05	≤-13.00	Pass
	2539.5	H	-44.79		
	3386	H	---		

LTE Band 5-10MHz					
Channel	Frequency (MHz)	Spurious Emission		Limit (dBm)	Result
		Polarization	Level (dBm)		
Low	1658	Vertical	-38.72	≤-13.00	Pass
	2487	V	-43.38		
	3316	V	---		
	1658	Horizontal	-42.25	≤-13.00	Pass
	2487	H	-45.95		
	3316	H	---		
Mid	1673	Vertical	-38.96	≤-13.00	Pass
	2509.5	V	-43.59		
	3346	V	---		
	1673	Horizontal	-41.08	≤-13.00	Pass
	2509.5	H	-45.74		
	3346	H	---		
High	1688	Vertical	-38.60	≤-13.00	Pass
	2532	V	-43.92		
	3376	V	-		
	1688	Horizontal	-40.96	≤-13.00	Pass
	2532	H	-45.85		
	3376	H	---		

Remark:

1. Remark"---" means that the emission level is too low to be measured
2. The emission levels of below 1 GHz are very lower than the limit and not show in test report.

LTE Band 13-5MHz					
Channel	Frequency (MHz)	Spurious Emission		Limit (dBm)	Result
		Polarization	Level (dBm)		
Low	1413	Vertical	-39.84	≤-13.00	Pass
	2119.5	V	-41.88		
	2826	V	---		
	1413	Horizontal	-40.79	≤-13.00	Pass
	2119.5	H	-44.28		
	2826	H	---		
Mid	1420	Vertical	-39.84	≤-13.00	Pass
	2130	V	-41.88		
	2840	V	---		
	1420	Horizontal	-39.62	≤-13.00	Pass
	2130	H	-42.78		
	2840	H	---		
High	1427	Vertical	-40.74	≤-13.00	Pass
	2140.5	V	-43.37		
	2854	V	---		
	1427	Horizontal	-39.11	≤-13.00	Pass
	2140.5	H	-43.48		
	2854	H	---		

LTE Band 13-10MHz					
Channel	Frequency (MHz)	Spurious Emission		Limit (dBm)	Result
		Polarization	Level (dBm)		
Mid	1418	Vertical	-39.95	<-13.00	Pass
	2127	V	-41.77		
	2836	V	---		
	1418	Horizontal	-41.27	<-13.00	Pass
	2127	H	-44.39		
	2836	H	---		

Remark:

1. Remark"---" means that the emission level is too low to be measured
2. The emission levels of below 1 GHz are very lower than the limit and not show in test report

6. TEST SETUP PHOTOS

Radiated emission:

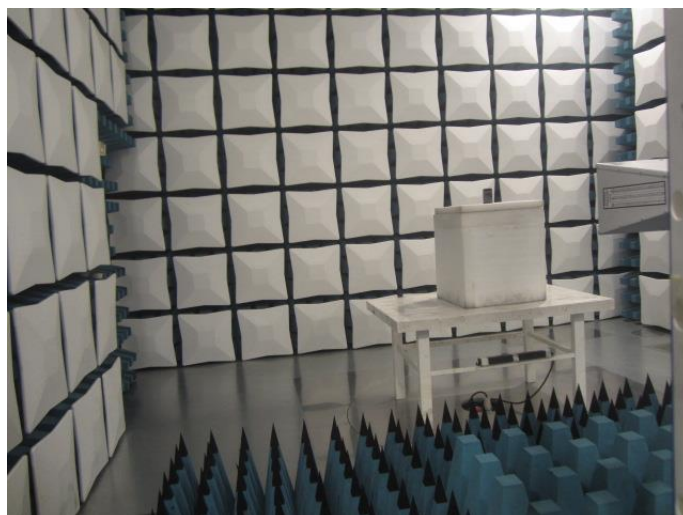
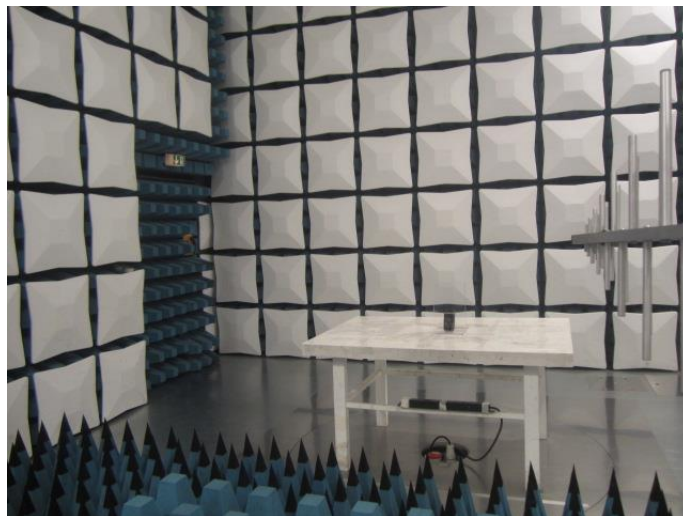

7. EXTERNAL AND INTERNAL PHOTOS

Refere to the test report No.: TRE1803009901.

8. APPENDIX REPORT



8.1 Appendix A: Conducted Output Power

Test Result

Band	Bandwidth	Modulation	Channel	RB Configuration	Result(dBm)	Verdict
Band2	1.4MHz	QPSK	18607	1RB#0	23.37	PASS
Band2	1.4MHz	QPSK	18607	1RB#2	23.13	PASS
Band2	1.4MHz	QPSK	18607	1RB#5	23.24	PASS
Band2	1.4MHz	QPSK	18607	3RB#0	23.33	PASS
Band2	1.4MHz	QPSK	18607	3RB#1	23.35	PASS
Band2	1.4MHz	QPSK	18607	3RB#3	23.33	PASS
Band2	1.4MHz	QPSK	18607	6RB#0	22.56	PASS
Band2	1.4MHz	QPSK	18900	1RB#0	23.49	PASS
Band2	1.4MHz	QPSK	18900	1RB#2	23.25	PASS
Band2	1.4MHz	QPSK	18900	1RB#5	23.36	PASS
Band2	1.4MHz	QPSK	18900	3RB#0	23.45	PASS
Band2	1.4MHz	QPSK	18900	3RB#1	23.47	PASS
Band2	1.4MHz	QPSK	18900	3RB#3	23.45	PASS
Band2	1.4MHz	QPSK	18900	6RB#0	22.68	PASS
Band2	1.4MHz	QPSK	19193	1RB#0	23.30	PASS
Band2	1.4MHz	QPSK	19193	1RB#2	23.07	PASS
Band2	1.4MHz	QPSK	19193	1RB#5	23.18	PASS
Band2	1.4MHz	QPSK	19193	3RB#0	23.26	PASS
Band2	1.4MHz	QPSK	19193	3RB#1	23.28	PASS
Band2	1.4MHz	QPSK	19193	3RB#3	23.26	PASS
Band2	1.4MHz	QPSK	19193	6RB#0	22.50	PASS
Band2	1.4MHz	16QAM	18607	1RB#0	22.66	PASS
Band2	1.4MHz	16QAM	18607	1RB#2	22.92	PASS
Band2	1.4MHz	16QAM	18607	1RB#5	22.81	PASS
Band2	1.4MHz	16QAM	18607	3RB#0	22.30	PASS
Band2	1.4MHz	16QAM	18607	3RB#1	22.37	PASS
Band2	1.4MHz	16QAM	18607	3RB#3	22.53	PASS
Band2	1.4MHz	16QAM	18607	6RB#0	21.22	PASS
Band2	1.4MHz	16QAM	18900	1RB#0	22.78	PASS
Band2	1.4MHz	16QAM	18900	1RB#2	23.04	PASS
Band2	1.4MHz	16QAM	18900	1RB#5	22.93	PASS
Band2	1.4MHz	16QAM	18900	3RB#0	22.41	PASS
Band2	1.4MHz	16QAM	18900	3RB#1	22.48	PASS
Band2	1.4MHz	16QAM	18900	3RB#3	22.65	PASS
Band2	1.4MHz	16QAM	18900	6RB#0	21.33	PASS
Band2	1.4MHz	16QAM	19193	1RB#0	22.60	PASS
Band2	1.4MHz	16QAM	19193	1RB#2	22.86	PASS
Band2	1.4MHz	16QAM	19193	1RB#5	22.75	PASS
Band2	1.4MHz	16QAM	19193	3RB#0	22.23	PASS
Band2	1.4MHz	16QAM	19193	3RB#1	22.30	PASS



Band2	1.4MHz	16QAM	19193	3RB#3	22.47	PASS
Band2	1.4MHz	16QAM	19193	6RB#0	21.16	PASS
Band2	3MHz	QPSK	18615	1RB#0	23.33	PASS
Band2	3MHz	QPSK	18615	1RB#8	23.36	PASS
Band2	3MHz	QPSK	18615	1RB#14	23.40	PASS
Band2	3MHz	QPSK	18615	8RB#0	22.49	PASS
Band2	3MHz	QPSK	18615	8RB#4	22.53	PASS
Band2	3MHz	QPSK	18615	8RB#7	22.50	PASS
Band2	3MHz	QPSK	18615	15RB#0	22.44	PASS
Band2	3MHz	QPSK	18900	1RB#0	23.45	PASS
Band2	3MHz	QPSK	18900	1RB#8	23.48	PASS
Band2	3MHz	QPSK	18900	1RB#14	23.52	PASS
Band2	3MHz	QPSK	18900	8RB#0	22.61	PASS
Band2	3MHz	QPSK	18900	8RB#4	22.65	PASS
Band2	3MHz	QPSK	18900	8RB#7	22.62	PASS
Band2	3MHz	QPSK	18900	15RB#0	22.56	PASS
Band2	3MHz	QPSK	19185	1RB#0	23.26	PASS
Band2	3MHz	QPSK	19185	1RB#8	23.29	PASS
Band2	3MHz	QPSK	19185	1RB#14	23.33	PASS
Band2	3MHz	QPSK	19185	8RB#0	22.43	PASS
Band2	3MHz	QPSK	19185	8RB#4	22.47	PASS
Band2	3MHz	QPSK	19185	8RB#7	22.44	PASS
Band2	3MHz	QPSK	19185	15RB#0	22.38	PASS
Band2	3MHz	16QAM	18615	1RB#0	22.87	PASS
Band2	3MHz	16QAM	18615	1RB#8	22.73	PASS
Band2	3MHz	16QAM	18615	1RB#14	22.89	PASS
Band2	3MHz	16QAM	18615	8RB#0	21.37	PASS
Band2	3MHz	16QAM	18615	8RB#4	21.39	PASS
Band2	3MHz	16QAM	18615	8RB#7	21.35	PASS
Band2	3MHz	16QAM	18615	15RB#0	21.53	PASS
Band2	3MHz	16QAM	18900	1RB#0	22.99	PASS
Band2	3MHz	16QAM	18900	1RB#8	22.85	PASS
Band2	3MHz	16QAM	18900	1RB#14	23.01	PASS
Band2	3MHz	16QAM	18900	8RB#0	21.48	PASS
Band2	3MHz	16QAM	18900	8RB#4	21.50	PASS
Band2	3MHz	16QAM	18900	8RB#7	21.46	PASS
Band2	3MHz	16QAM	18900	15RB#0	21.64	PASS
Band2	3MHz	16QAM	19185	1RB#0	22.81	PASS
Band2	3MHz	16QAM	19185	1RB#8	22.67	PASS
Band2	3MHz	16QAM	19185	1RB#14	22.83	PASS
Band2	3MHz	16QAM	19185	8RB#0	21.31	PASS
Band2	3MHz	16QAM	19185	8RB#4	21.33	PASS
Band2	3MHz	16QAM	19185	8RB#7	21.29	PASS
Band2	3MHz	16QAM	19185	15RB#0	21.47	PASS
Band2	5MHz	QPSK	18625	1RB#0	23.23	PASS



Band2	5MHz	QPSK	18625	1RB#12	23.57	PASS
Band2	5MHz	QPSK	18625	1RB#24	23.31	PASS
Band2	5MHz	QPSK	18625	12RB#0	22.43	PASS
Band2	5MHz	QPSK	18625	12RB#6	22.48	PASS
Band2	5MHz	QPSK	18625	12RB#13	22.52	PASS
Band2	5MHz	QPSK	18625	25RB#0	22.51	PASS
Band2	5MHz	QPSK	18900	1RB#0	23.35	PASS
Band2	5MHz	QPSK	18900	1RB#12	23.69	PASS
Band2	5MHz	QPSK	18900	1RB#24	23.43	PASS
Band2	5MHz	QPSK	18900	12RB#0	22.55	PASS
Band2	5MHz	QPSK	18900	12RB#6	22.60	PASS
Band2	5MHz	QPSK	18900	12RB#13	22.64	PASS
Band2	5MHz	QPSK	18900	25RB#0	22.63	PASS
Band2	5MHz	QPSK	19175	1RB#0	23.17	PASS
Band2	5MHz	QPSK	19175	1RB#12	23.50	PASS
Band2	5MHz	QPSK	19175	1RB#24	23.24	PASS
Band2	5MHz	QPSK	19175	12RB#0	22.37	PASS
Band2	5MHz	QPSK	19175	12RB#6	22.42	PASS
Band2	5MHz	QPSK	19175	12RB#13	22.46	PASS
Band2	5MHz	QPSK	19175	25RB#0	22.45	PASS
Band2	5MHz	16QAM	18625	1RB#0	22.16	PASS
Band2	5MHz	16QAM	18625	1RB#12	22.51	PASS
Band2	5MHz	16QAM	18625	1RB#24	22.26	PASS
Band2	5MHz	16QAM	18625	12RB#0	21.43	PASS
Band2	5MHz	16QAM	18625	12RB#6	21.45	PASS
Band2	5MHz	16QAM	18625	12RB#13	21.31	PASS
Band2	5MHz	16QAM	18625	25RB#0	21.66	PASS
Band2	5MHz	16QAM	18900	1RB#0	22.27	PASS
Band2	5MHz	16QAM	18900	1RB#12	22.63	PASS
Band2	5MHz	16QAM	18900	1RB#24	22.37	PASS
Band2	5MHz	16QAM	18900	12RB#0	21.54	PASS
Band2	5MHz	16QAM	18900	12RB#6	21.56	PASS
Band2	5MHz	16QAM	18900	12RB#13	21.42	PASS
Band2	5MHz	16QAM	18900	25RB#0	21.77	PASS
Band2	5MHz	16QAM	19175	1RB#0	22.09	PASS
Band2	5MHz	16QAM	19175	1RB#12	22.45	PASS
Band2	5MHz	16QAM	19175	1RB#24	22.19	PASS
Band2	5MHz	16QAM	19175	12RB#0	21.37	PASS
Band2	5MHz	16QAM	19175	12RB#6	21.39	PASS
Band2	5MHz	16QAM	19175	12RB#13	21.25	PASS
Band2	5MHz	16QAM	19175	25RB#0	21.60	PASS
Band2	10MHz	QPSK	18650	1RB#0	23.41	PASS
Band2	10MHz	QPSK	18650	1RB#24	23.69	PASS
Band2	10MHz	QPSK	18650	1RB#49	23.56	PASS
Band2	10MHz	QPSK	18650	25RB#0	22.45	PASS



Band2	10MHz	QPSK	18650	25RB#12	22.50	PASS
Band2	10MHz	QPSK	18650	25RB#25	22.54	PASS
Band2	10MHz	QPSK	18650	50RB#0	22.46	PASS
Band2	10MHz	QPSK	18900	1RB#0	23.53	PASS
Band2	10MHz	QPSK	18900	1RB#24	23.81	PASS
Band2	10MHz	QPSK	18900	1RB#49	23.68	PASS
Band2	10MHz	QPSK	18900	25RB#0	22.57	PASS
Band2	10MHz	QPSK	18900	25RB#12	22.62	PASS
Band2	10MHz	QPSK	18900	25RB#25	22.66	PASS
Band2	10MHz	QPSK	18900	50RB#0	22.58	PASS
Band2	10MHz	QPSK	19150	1RB#0	23.34	PASS
Band2	10MHz	QPSK	19150	1RB#24	23.62	PASS
Band2	10MHz	QPSK	19150	1RB#49	23.49	PASS
Band2	10MHz	QPSK	19150	25RB#0	22.39	PASS
Band2	10MHz	QPSK	19150	25RB#12	22.44	PASS
Band2	10MHz	QPSK	19150	25RB#25	22.48	PASS
Band2	10MHz	QPSK	19150	50RB#0	22.40	PASS
Band2	10MHz	16QAM	18650	1RB#0	22.43	PASS
Band2	10MHz	16QAM	18650	1RB#24	22.35	PASS
Band2	10MHz	16QAM	18650	1RB#49	22.45	PASS
Band2	10MHz	16QAM	18650	25RB#0	21.56	PASS
Band2	10MHz	16QAM	18650	25RB#12	21.70	PASS
Band2	10MHz	16QAM	18650	25RB#25	21.63	PASS
Band2	10MHz	16QAM	18650	50RB#0	21.50	PASS
Band2	10MHz	16QAM	18900	1RB#0	22.55	PASS
Band2	10MHz	16QAM	18900	1RB#24	22.46	PASS
Band2	10MHz	16QAM	18900	1RB#49	22.57	PASS
Band2	10MHz	16QAM	18900	25RB#0	21.67	PASS
Band2	10MHz	16QAM	18900	25RB#12	21.81	PASS
Band2	10MHz	16QAM	18900	25RB#25	21.74	PASS
Band2	10MHz	16QAM	18900	50RB#0	21.61	PASS
Band2	10MHz	16QAM	19150	1RB#0	22.37	PASS
Band2	10MHz	16QAM	19150	1RB#24	22.28	PASS
Band2	10MHz	16QAM	19150	1RB#49	22.39	PASS
Band2	10MHz	16QAM	19150	25RB#0	21.50	PASS
Band2	10MHz	16QAM	19150	25RB#12	21.64	PASS
Band2	10MHz	16QAM	19150	25RB#25	21.57	PASS
Band2	10MHz	16QAM	19150	50RB#0	21.44	PASS
Band2	15MHz	QPSK	18675	1RB#0	23.31	PASS
Band2	15MHz	QPSK	18675	1RB#38	23.37	PASS
Band2	15MHz	QPSK	18675	1RB#74	23.43	PASS
Band2	15MHz	QPSK	18675	38RB#0	22.41	PASS
Band2	15MHz	QPSK	18675	38RB#18	22.41	PASS
Band2	15MHz	QPSK	18675	38RB#37	22.51	PASS
Band2	15MHz	QPSK	18675	75RB#0	22.44	PASS



Band2	15MHz	QPSK	18900	1RB#0	23.43	PASS
Band2	15MHz	QPSK	18900	1RB#38	23.49	PASS
Band2	15MHz	QPSK	18900	1RB#74	23.55	PASS
Band2	15MHz	QPSK	18900	38RB#0	22.52	PASS
Band2	15MHz	QPSK	18900	38RB#18	22.52	PASS
Band2	15MHz	QPSK	18900	38RB#37	22.63	PASS
Band2	15MHz	QPSK	18900	75RB#0	22.56	PASS
Band2	15MHz	QPSK	19125	1RB#0	23.24	PASS
Band2	15MHz	QPSK	19125	1RB#38	23.30	PASS
Band2	15MHz	QPSK	19125	1RB#74	23.36	PASS
Band2	15MHz	QPSK	19125	38RB#0	22.34	PASS
Band2	15MHz	QPSK	19125	38RB#18	22.34	PASS
Band2	15MHz	QPSK	19125	38RB#37	22.45	PASS
Band2	15MHz	QPSK	19125	75RB#0	22.38	PASS
Band2	15MHz	16QAM	18675	1RB#0	22.47	PASS
Band2	15MHz	16QAM	18675	1RB#38	22.23	PASS
Band2	15MHz	16QAM	18675	1RB#74	22.31	PASS
Band2	15MHz	16QAM	18675	38RB#0	21.39	PASS
Band2	15MHz	16QAM	18675	38RB#18	21.40	PASS
Band2	15MHz	16QAM	18675	38RB#37	21.51	PASS
Band2	15MHz	16QAM	18675	75RB#0	21.34	PASS
Band2	15MHz	16QAM	18900	1RB#0	22.59	PASS
Band2	15MHz	16QAM	18900	1RB#38	22.34	PASS
Band2	15MHz	16QAM	18900	1RB#74	22.42	PASS
Band2	15MHz	16QAM	18900	38RB#0	21.50	PASS
Band2	15MHz	16QAM	18900	38RB#18	21.51	PASS
Band2	15MHz	16QAM	18900	38RB#37	21.62	PASS
Band2	15MHz	16QAM	18900	75RB#0	21.45	PASS
Band2	15MHz	16QAM	19125	1RB#0	22.41	PASS
Band2	15MHz	16QAM	19125	1RB#38	22.16	PASS
Band2	15MHz	16QAM	19125	1RB#74	22.24	PASS
Band2	15MHz	16QAM	19125	38RB#0	21.33	PASS
Band2	15MHz	16QAM	19125	38RB#18	21.34	PASS
Band2	15MHz	16QAM	19125	38RB#37	21.45	PASS
Band2	15MHz	16QAM	19125	75RB#0	21.28	PASS
Band2	20MHz	QPSK	18700	1RB#0	23.31	PASS
Band2	20MHz	QPSK	18700	1RB#49	23.41	PASS
Band2	20MHz	QPSK	18700	1RB#99	23.39	PASS
Band2	20MHz	QPSK	18700	50RB#0	22.41	PASS
Band2	20MHz	QPSK	18700	50RB#25	22.38	PASS
Band2	20MHz	QPSK	18700	50RB#50	22.50	PASS
Band2	20MHz	QPSK	18700	100RB#0	22.43	PASS
Band2	20MHz	QPSK	18900	1RB#0	23.43	PASS
Band2	20MHz	QPSK	18900	1RB#49	23.53	PASS
Band2	20MHz	QPSK	18900	1RB#99	23.51	PASS



Band2	20MHz	QPSK	18900	50RB#0	22.52	PASS
Band2	20MHz	QPSK	18900	50RB#25	22.49	PASS
Band2	20MHz	QPSK	18900	50RB#50	22.62	PASS
Band2	20MHz	QPSK	18900	100RB#0	22.55	PASS
Band2	20MHz	QPSK	19100	1RB#0	23.24	PASS
Band2	20MHz	QPSK	19100	1RB#49	23.34	PASS
Band2	20MHz	QPSK	19100	1RB#99	23.32	PASS
Band2	20MHz	QPSK	19100	50RB#0	22.34	PASS
Band2	20MHz	QPSK	19100	50RB#25	22.31	PASS
Band2	20MHz	QPSK	19100	50RB#50	22.44	PASS
Band2	20MHz	QPSK	19100	100RB#0	22.37	PASS
Band2	20MHz	16QAM	18700	1RB#0	22.20	PASS
Band2	20MHz	16QAM	18700	1RB#49	22.63	PASS
Band2	20MHz	16QAM	18700	1RB#99	22.16	PASS
Band2	20MHz	16QAM	18700	50RB#0	21.51	PASS
Band2	20MHz	16QAM	18700	50RB#25	21.35	PASS
Band2	20MHz	16QAM	18700	50RB#50	21.54	PASS
Band2	20MHz	16QAM	18700	100RB#0	21.28	PASS
Band2	20MHz	16QAM	18900	1RB#0	22.31	PASS
Band2	20MHz	16QAM	18900	1RB#49	22.75	PASS
Band2	20MHz	16QAM	18900	1RB#99	22.27	PASS
Band2	20MHz	16QAM	18900	50RB#0	21.62	PASS
Band2	20MHz	16QAM	18900	50RB#25	21.46	PASS
Band2	20MHz	16QAM	18900	50RB#50	21.65	PASS
Band2	20MHz	16QAM	18900	100RB#0	21.39	PASS
Band2	20MHz	16QAM	19100	1RB#0	22.13	PASS
Band2	20MHz	16QAM	19100	1RB#49	22.57	PASS
Band2	20MHz	16QAM	19100	1RB#99	22.09	PASS
Band2	20MHz	16QAM	19100	50RB#0	21.45	PASS
Band2	20MHz	16QAM	19100	50RB#25	21.29	PASS
Band2	20MHz	16QAM	19100	50RB#50	21.48	PASS
Band2	20MHz	16QAM	19100	100RB#0	21.22	PASS
Band4	1.4MHz	QPSK	19957	1RB#0	24.29	PASS
Band4	1.4MHz	QPSK	19957	1RB#2	24.33	PASS
Band4	1.4MHz	QPSK	19957	1RB#5	24.19	PASS
Band4	1.4MHz	QPSK	19957	3RB#0	24.22	PASS
Band4	1.4MHz	QPSK	19957	3RB#1	24.21	PASS
Band4	1.4MHz	QPSK	19957	3RB#3	24.14	PASS
Band4	1.4MHz	QPSK	19957	6RB#0	23.27	PASS
Band4	1.4MHz	QPSK	20175	1RB#0	24.51	PASS
Band4	1.4MHz	QPSK	20175	1RB#2	24.55	PASS
Band4	1.4MHz	QPSK	20175	1RB#5	24.41	PASS
Band4	1.4MHz	QPSK	20175	3RB#0	24.44	PASS
Band4	1.4MHz	QPSK	20175	3RB#1	24.43	PASS
Band4	1.4MHz	QPSK	20175	3RB#3	24.36	PASS



Band4	1.4MHz	QPSK	20175	6RB#0	23.48	PASS
Band4	1.4MHz	QPSK	20393	1RB#0	24.42	PASS
Band4	1.4MHz	QPSK	20393	1RB#2	24.46	PASS
Band4	1.4MHz	QPSK	20393	1RB#5	24.32	PASS
Band4	1.4MHz	QPSK	20393	3RB#0	24.35	PASS
Band4	1.4MHz	QPSK	20393	3RB#1	24.34	PASS
Band4	1.4MHz	QPSK	20393	3RB#3	24.27	PASS
Band4	1.4MHz	QPSK	20393	6RB#0	23.39	PASS
Band4	1.4MHz	16QAM	19957	1RB#0	23.57	PASS
Band4	1.4MHz	16QAM	19957	1RB#2	23.95	PASS
Band4	1.4MHz	16QAM	19957	1RB#5	23.73	PASS
Band4	1.4MHz	16QAM	19957	3RB#0	23.44	PASS
Band4	1.4MHz	16QAM	19957	3RB#1	23.24	PASS
Band4	1.4MHz	16QAM	19957	3RB#3	23.22	PASS
Band4	1.4MHz	16QAM	19957	6RB#0	22.11	PASS
Band4	1.4MHz	16QAM	20175	1RB#0	23.78	PASS
Band4	1.4MHz	16QAM	20175	1RB#2	24.17	PASS
Band4	1.4MHz	16QAM	20175	1RB#5	23.94	PASS
Band4	1.4MHz	16QAM	20175	3RB#0	23.65	PASS
Band4	1.4MHz	16QAM	20175	3RB#1	23.45	PASS
Band4	1.4MHz	16QAM	20175	3RB#3	23.43	PASS
Band4	1.4MHz	16QAM	20175	6RB#0	22.31	PASS
Band4	1.4MHz	16QAM	20393	1RB#0	23.69	PASS
Band4	1.4MHz	16QAM	20393	1RB#2	24.08	PASS
Band4	1.4MHz	16QAM	20393	1RB#5	23.85	PASS
Band4	1.4MHz	16QAM	20393	3RB#0	23.56	PASS
Band4	1.4MHz	16QAM	20393	3RB#1	23.36	PASS
Band4	1.4MHz	16QAM	20393	3RB#3	23.34	PASS
Band4	1.4MHz	16QAM	20393	6RB#0	22.22	PASS
Band4	3MHz	QPSK	19965	1RB#0	24.20	PASS
Band4	3MHz	QPSK	19965	1RB#8	24.16	PASS
Band4	3MHz	QPSK	19965	1RB#14	24.11	PASS
Band4	3MHz	QPSK	19965	8RB#0	23.22	PASS
Band4	3MHz	QPSK	19965	8RB#4	23.36	PASS
Band4	3MHz	QPSK	19965	8RB#7	23.35	PASS
Band4	3MHz	QPSK	19965	15RB#0	23.26	PASS
Band4	3MHz	QPSK	20175	1RB#0	24.42	PASS
Band4	3MHz	QPSK	20175	1RB#8	24.38	PASS
Band4	3MHz	QPSK	20175	1RB#14	24.33	PASS
Band4	3MHz	QPSK	20175	8RB#0	23.43	PASS
Band4	3MHz	QPSK	20175	8RB#4	23.57	PASS
Band4	3MHz	QPSK	20175	8RB#7	23.56	PASS
Band4	3MHz	QPSK	20175	15RB#0	23.47	PASS
Band4	3MHz	QPSK	20385	1RB#0	24.33	PASS
Band4	3MHz	QPSK	20385	1RB#8	24.29	PASS



Band4	3MHz	QPSK	20385	1RB#14	24.24	PASS
Band4	3MHz	QPSK	20385	8RB#0	23.34	PASS
Band4	3MHz	QPSK	20385	8RB#4	23.48	PASS
Band4	3MHz	QPSK	20385	8RB#7	23.47	PASS
Band4	3MHz	QPSK	20385	15RB#0	23.38	PASS
Band4	3MHz	16QAM	19965	1RB#0	23.58	PASS
Band4	3MHz	16QAM	19965	1RB#8	23.64	PASS
Band4	3MHz	16QAM	19965	1RB#14	23.65	PASS
Band4	3MHz	16QAM	19965	8RB#0	22.33	PASS
Band4	3MHz	16QAM	19965	8RB#4	22.34	PASS
Band4	3MHz	16QAM	19965	8RB#7	22.45	PASS
Band4	3MHz	16QAM	19965	15RB#0	22.26	PASS
Band4	3MHz	16QAM	20175	1RB#0	23.79	PASS
Band4	3MHz	16QAM	20175	1RB#8	23.85	PASS
Band4	3MHz	16QAM	20175	1RB#14	23.86	PASS
Band4	3MHz	16QAM	20175	8RB#0	22.53	PASS
Band4	3MHz	16QAM	20175	8RB#4	22.54	PASS
Band4	3MHz	16QAM	20175	8RB#7	22.65	PASS
Band4	3MHz	16QAM	20175	15RB#0	22.46	PASS
Band4	3MHz	16QAM	20385	1RB#0	23.70	PASS
Band4	3MHz	16QAM	20385	1RB#8	23.76	PASS
Band4	3MHz	16QAM	20385	1RB#14	23.77	PASS
Band4	3MHz	16QAM	20385	8RB#0	22.44	PASS
Band4	3MHz	16QAM	20385	8RB#4	22.45	PASS
Band4	3MHz	16QAM	20385	8RB#7	22.56	PASS
Band4	3MHz	16QAM	20385	15RB#0	22.37	PASS
Band4	5MHz	QPSK	19975	1RB#0	24.09	PASS
Band4	5MHz	QPSK	19975	1RB#12	24.75	PASS
Band4	5MHz	QPSK	19975	1RB#24	24.29	PASS
Band4	5MHz	QPSK	19975	12RB#0	23.24	PASS
Band4	5MHz	QPSK	19975	12RB#6	23.33	PASS
Band4	5MHz	QPSK	19975	12RB#13	23.24	PASS
Band4	5MHz	QPSK	19975	25RB#0	23.21	PASS
Band4	5MHz	QPSK	20175	1RB#0	24.31	PASS
Band4	5MHz	QPSK	20175	1RB#12	24.97	PASS
Band4	5MHz	QPSK	20175	1RB#24	24.51	PASS
Band4	5MHz	QPSK	20175	12RB#0	23.45	PASS
Band4	5MHz	QPSK	20175	12RB#6	23.54	PASS
Band4	5MHz	QPSK	20175	12RB#13	23.45	PASS
Band4	5MHz	QPSK	20175	25RB#0	23.42	PASS
Band4	5MHz	QPSK	20375	1RB#0	24.22	PASS
Band4	5MHz	QPSK	20375	1RB#12	24.87	PASS
Band4	5MHz	QPSK	20375	1RB#24	24.42	PASS
Band4	5MHz	QPSK	20375	12RB#0	23.36	PASS
Band4	5MHz	QPSK	20375	12RB#6	23.45	PASS



Band4	5MHz	QPSK	20375	12RB#13	23.36	PASS
Band4	5MHz	QPSK	20375	25RB#0	23.33	PASS
Band4	5MHz	16QAM	19975	1RB#0	23.28	PASS
Band4	5MHz	16QAM	19975	1RB#12	23.42	PASS
Band4	5MHz	16QAM	19975	1RB#24	23.26	PASS
Band4	5MHz	16QAM	19975	12RB#0	22.26	PASS
Band4	5MHz	16QAM	19975	12RB#6	22.43	PASS
Band4	5MHz	16QAM	19975	12RB#13	22.43	PASS
Band4	5MHz	16QAM	19975	25RB#0	22.29	PASS
Band4	5MHz	16QAM	20175	1RB#0	23.49	PASS
Band4	5MHz	16QAM	20175	1RB#12	23.63	PASS
Band4	5MHz	16QAM	20175	1RB#24	23.47	PASS
Band4	5MHz	16QAM	20175	12RB#0	22.46	PASS
Band4	5MHz	16QAM	20175	12RB#6	22.63	PASS
Band4	5MHz	16QAM	20175	12RB#13	22.63	PASS
Band4	5MHz	16QAM	20175	25RB#0	22.49	PASS
Band4	5MHz	16QAM	20375	1RB#0	23.40	PASS
Band4	5MHz	16QAM	20375	1RB#12	23.54	PASS
Band4	5MHz	16QAM	20375	1RB#24	23.38	PASS
Band4	5MHz	16QAM	20375	12RB#0	22.37	PASS
Band4	5MHz	16QAM	20375	12RB#6	22.54	PASS
Band4	5MHz	16QAM	20375	12RB#13	22.54	PASS
Band4	5MHz	16QAM	20375	25RB#0	22.40	PASS
Band4	10MHz	QPSK	20000	1RB#0	24.18	PASS
Band4	10MHz	QPSK	20000	1RB#24	24.33	PASS
Band4	10MHz	QPSK	20000	1RB#49	24.46	PASS
Band4	10MHz	QPSK	20000	25RB#0	23.24	PASS
Band4	10MHz	QPSK	20000	25RB#12	23.29	PASS
Band4	10MHz	QPSK	20000	25RB#25	23.33	PASS
Band4	10MHz	QPSK	20000	50RB#0	23.27	PASS
Band4	10MHz	QPSK	20175	1RB#0	24.40	PASS
Band4	10MHz	QPSK	20175	1RB#24	24.55	PASS
Band4	10MHz	QPSK	20175	1RB#49	24.68	PASS
Band4	10MHz	QPSK	20175	25RB#0	23.45	PASS
Band4	10MHz	QPSK	20175	25RB#12	23.50	PASS
Band4	10MHz	QPSK	20175	25RB#25	23.54	PASS
Band4	10MHz	QPSK	20175	50RB#0	23.48	PASS
Band4	10MHz	QPSK	20350	1RB#0	24.31	PASS
Band4	10MHz	QPSK	20350	1RB#24	24.46	PASS
Band4	10MHz	QPSK	20350	1RB#49	24.59	PASS
Band4	10MHz	QPSK	20350	25RB#0	23.36	PASS
Band4	10MHz	QPSK	20350	25RB#12	23.41	PASS
Band4	10MHz	QPSK	20350	25RB#25	23.45	PASS
Band4	10MHz	QPSK	20350	50RB#0	23.39	PASS
Band4	10MHz	16QAM	20000	1RB#0	23.39	PASS



Band4	10MHz	16QAM	20000	1RB#24	23.85	PASS
Band4	10MHz	16QAM	20000	1RB#49	23.62	PASS
Band4	10MHz	16QAM	20000	25RB#0	22.33	PASS
Band4	10MHz	16QAM	20000	25RB#12	22.43	PASS
Band4	10MHz	16QAM	20000	25RB#25	22.49	PASS
Band4	10MHz	16QAM	20000	50RB#0	22.20	PASS
Band4	10MHz	16QAM	20175	1RB#0	23.60	PASS
Band4	10MHz	16QAM	20175	1RB#24	24.07	PASS
Band4	10MHz	16QAM	20175	1RB#49	23.83	PASS
Band4	10MHz	16QAM	20175	25RB#0	22.53	PASS
Band4	10MHz	16QAM	20175	25RB#12	22.63	PASS
Band4	10MHz	16QAM	20175	25RB#25	22.69	PASS
Band4	10MHz	16QAM	20175	50RB#0	22.40	PASS
Band4	10MHz	16QAM	20350	1RB#0	23.51	PASS
Band4	10MHz	16QAM	20350	1RB#24	23.98	PASS
Band4	10MHz	16QAM	20350	1RB#49	23.74	PASS
Band4	10MHz	16QAM	20350	25RB#0	22.44	PASS
Band4	10MHz	16QAM	20350	25RB#12	22.54	PASS
Band4	10MHz	16QAM	20350	25RB#25	22.60	PASS
Band4	10MHz	16QAM	20350	50RB#0	22.31	PASS
Band4	15MHz	QPSK	20025	1RB#0	24.16	PASS
Band4	15MHz	QPSK	20025	1RB#38	24.06	PASS
Band4	15MHz	QPSK	20025	1RB#74	23.98	PASS
Band4	15MHz	QPSK	20025	38RB#0	23.14	PASS
Band4	15MHz	QPSK	20025	38RB#18	23.29	PASS
Band4	15MHz	QPSK	20025	38RB#37	23.21	PASS
Band4	15MHz	QPSK	20025	75RB#0	23.27	PASS
Band4	15MHz	QPSK	20175	1RB#0	24.38	PASS
Band4	15MHz	QPSK	20175	1RB#38	24.28	PASS
Band4	15MHz	QPSK	20175	1RB#74	24.20	PASS
Band4	15MHz	QPSK	20175	38RB#0	23.35	PASS
Band4	15MHz	QPSK	20175	38RB#18	23.50	PASS
Band4	15MHz	QPSK	20175	38RB#37	23.42	PASS
Band4	15MHz	QPSK	20175	75RB#0	23.48	PASS
Band4	15MHz	QPSK	20325	1RB#0	24.29	PASS
Band4	15MHz	QPSK	20325	1RB#38	24.19	PASS
Band4	15MHz	QPSK	20325	1RB#74	24.11	PASS
Band4	15MHz	QPSK	20325	38RB#0	23.26	PASS
Band4	15MHz	QPSK	20325	38RB#18	23.41	PASS
Band4	15MHz	QPSK	20325	38RB#37	23.33	PASS
Band4	15MHz	QPSK	20325	75RB#0	23.39	PASS
Band4	15MHz	16QAM	20025	1RB#0	23.58	PASS
Band4	15MHz	16QAM	20025	1RB#38	23.64	PASS
Band4	15MHz	16QAM	20025	1RB#74	23.67	PASS
Band4	15MHz	16QAM	20025	38RB#0	22.22	PASS



Band4	15MHz	16QAM	20025	38RB#18	22.26	PASS
Band4	15MHz	16QAM	20025	38RB#37	22.30	PASS
Band4	15MHz	16QAM	20025	75RB#0	22.27	PASS
Band4	15MHz	16QAM	20175	1RB#0	23.79	PASS
Band4	15MHz	16QAM	20175	1RB#38	23.85	PASS
Band4	15MHz	16QAM	20175	1RB#74	23.88	PASS
Band4	15MHz	16QAM	20175	38RB#0	22.42	PASS
Band4	15MHz	16QAM	20175	38RB#18	22.46	PASS
Band4	15MHz	16QAM	20175	38RB#37	22.50	PASS
Band4	15MHz	16QAM	20175	75RB#0	22.47	PASS
Band4	15MHz	16QAM	20325	1RB#0	23.70	PASS
Band4	15MHz	16QAM	20325	1RB#38	23.76	PASS
Band4	15MHz	16QAM	20325	1RB#74	23.79	PASS
Band4	15MHz	16QAM	20325	38RB#0	22.33	PASS
Band4	15MHz	16QAM	20325	38RB#18	22.37	PASS
Band4	15MHz	16QAM	20325	38RB#37	22.41	PASS
Band4	15MHz	16QAM	20325	75RB#0	22.38	PASS
Band4	20MHz	QPSK	20050	1RB#0	23.99	PASS
Band4	20MHz	QPSK	20050	1RB#49	24.23	PASS
Band4	20MHz	QPSK	20050	1RB#99	24.33	PASS
Band4	20MHz	QPSK	20050	50RB#0	23.22	PASS
Band4	20MHz	QPSK	20050	50RB#25	23.22	PASS
Band4	20MHz	QPSK	20050	50RB#50	23.20	PASS
Band4	20MHz	QPSK	20050	100RB#0	23.26	PASS
Band4	20MHz	QPSK	20175	1RB#0	24.21	PASS
Band4	20MHz	QPSK	20175	1RB#49	24.45	PASS
Band4	20MHz	QPSK	20175	1RB#99	24.55	PASS
Band4	20MHz	QPSK	20175	50RB#0	23.43	PASS
Band4	20MHz	QPSK	20175	50RB#25	23.43	PASS
Band4	20MHz	QPSK	20175	50RB#50	23.41	PASS
Band4	20MHz	QPSK	20175	100RB#0	23.47	PASS
Band4	20MHz	QPSK	20300	1RB#0	24.12	PASS
Band4	20MHz	QPSK	20300	1RB#49	24.36	PASS
Band4	20MHz	QPSK	20300	1RB#99	24.46	PASS
Band4	20MHz	QPSK	20300	50RB#0	23.34	PASS
Band4	20MHz	QPSK	20300	50RB#25	23.34	PASS
Band4	20MHz	QPSK	20300	50RB#50	23.32	PASS
Band4	20MHz	QPSK	20300	100RB#0	23.38	PASS
Band4	20MHz	16QAM	20050	1RB#0	23.23	PASS
Band4	20MHz	16QAM	20050	1RB#49	23.87	PASS
Band4	20MHz	16QAM	20050	1RB#99	23.24	PASS
Band4	20MHz	16QAM	20050	50RB#0	22.23	PASS
Band4	20MHz	16QAM	20050	50RB#25	22.30	PASS
Band4	20MHz	16QAM	20050	50RB#50	22.17	PASS
Band4	20MHz	16QAM	20050	100RB#0	22.21	PASS



Band4	20MHz	16QAM	20175	1RB#0	23.44	PASS
Band4	20MHz	16QAM	20175	1RB#49	24.09	PASS
Band4	20MHz	16QAM	20175	1RB#99	23.45	PASS
Band4	20MHz	16QAM	20175	50RB#0	22.43	PASS
Band4	20MHz	16QAM	20175	50RB#25	22.50	PASS
Band4	20MHz	16QAM	20175	50RB#50	22.37	PASS
Band4	20MHz	16QAM	20175	100RB#0	22.41	PASS
Band4	20MHz	16QAM	20300	1RB#0	23.35	PASS
Band4	20MHz	16QAM	20300	1RB#49	24.00	PASS
Band4	20MHz	16QAM	20300	1RB#99	23.36	PASS
Band4	20MHz	16QAM	20300	50RB#0	22.34	PASS
Band4	20MHz	16QAM	20300	50RB#25	22.41	PASS
Band4	20MHz	16QAM	20300	50RB#50	22.28	PASS
Band4	20MHz	16QAM	20300	100RB#0	22.32	PASS
Band5	1.4MHz	QPSK	20407	1RB#0	23.51	PASS
Band5	1.4MHz	QPSK	20407	1RB#2	23.63	PASS
Band5	1.4MHz	QPSK	20407	1RB#5	23.55	PASS
Band5	1.4MHz	QPSK	20407	3RB#0	23.62	PASS
Band5	1.4MHz	QPSK	20407	3RB#1	23.67	PASS
Band5	1.4MHz	QPSK	20407	3RB#3	23.52	PASS
Band5	1.4MHz	QPSK	20407	6RB#0	22.63	PASS
Band5	1.4MHz	QPSK	20525	1RB#0	23.72	PASS
Band5	1.4MHz	QPSK	20525	1RB#2	23.84	PASS
Band5	1.4MHz	QPSK	20525	1RB#5	23.76	PASS
Band5	1.4MHz	QPSK	20525	3RB#0	23.83	PASS
Band5	1.4MHz	QPSK	20525	3RB#1	23.88	PASS
Band5	1.4MHz	QPSK	20525	3RB#3	23.73	PASS
Band5	1.4MHz	QPSK	20525	6RB#0	22.83	PASS
Band5	1.4MHz	QPSK	20643	1RB#0	23.60	PASS
Band5	1.4MHz	QPSK	20643	1RB#2	23.72	PASS
Band5	1.4MHz	QPSK	20643	1RB#5	23.64	PASS
Band5	1.4MHz	QPSK	20643	3RB#0	23.71	PASS
Band5	1.4MHz	QPSK	20643	3RB#1	23.76	PASS
Band5	1.4MHz	QPSK	20643	3RB#3	23.61	PASS
Band5	1.4MHz	QPSK	20643	6RB#0	22.71	PASS
Band5	1.4MHz	16QAM	20407	1RB#0	22.95	PASS
Band5	1.4MHz	16QAM	20407	1RB#2	23.04	PASS
Band5	1.4MHz	16QAM	20407	1RB#5	22.96	PASS
Band5	1.4MHz	16QAM	20407	3RB#0	22.61	PASS
Band5	1.4MHz	16QAM	20407	3RB#1	22.71	PASS
Band5	1.4MHz	16QAM	20407	3RB#3	22.62	PASS
Band5	1.4MHz	16QAM	20407	6RB#0	21.58	PASS
Band5	1.4MHz	16QAM	20525	1RB#0	23.16	PASS
Band5	1.4MHz	16QAM	20525	1RB#2	23.25	PASS
Band5	1.4MHz	16QAM	20525	1RB#5	23.17	PASS



Band5	1.4MHz	16QAM	20525	3RB#0	22.81	PASS
Band5	1.4MHz	16QAM	20525	3RB#1	22.92	PASS
Band5	1.4MHz	16QAM	20525	3RB#3	22.82	PASS
Band5	1.4MHz	16QAM	20525	6RB#0	21.78	PASS
Band5	1.4MHz	16QAM	20643	1RB#0	23.04	PASS
Band5	1.4MHz	16QAM	20643	1RB#2	23.13	PASS
Band5	1.4MHz	16QAM	20643	1RB#5	23.05	PASS
Band5	1.4MHz	16QAM	20643	3RB#0	22.69	PASS
Band5	1.4MHz	16QAM	20643	3RB#1	22.80	PASS
Band5	1.4MHz	16QAM	20643	3RB#3	22.70	PASS
Band5	1.4MHz	16QAM	20643	6RB#0	21.67	PASS
Band5	3MHz	QPSK	20415	1RB#0	23.66	PASS
Band5	3MHz	QPSK	20415	1RB#8	23.65	PASS
Band5	3MHz	QPSK	20415	1RB#14	23.54	PASS
Band5	3MHz	QPSK	20415	8RB#0	22.71	PASS
Band5	3MHz	QPSK	20415	8RB#4	22.69	PASS
Band5	3MHz	QPSK	20415	8RB#7	22.59	PASS
Band5	3MHz	QPSK	20415	15RB#0	22.65	PASS
Band5	3MHz	QPSK	20525	1RB#0	23.87	PASS
Band5	3MHz	QPSK	20525	1RB#8	23.86	PASS
Band5	3MHz	QPSK	20525	1RB#14	23.75	PASS
Band5	3MHz	QPSK	20525	8RB#0	22.92	PASS
Band5	3MHz	QPSK	20525	8RB#4	22.90	PASS
Band5	3MHz	QPSK	20525	8RB#7	22.79	PASS
Band5	3MHz	QPSK	20525	15RB#0	22.86	PASS
Band5	3MHz	QPSK	20635	1RB#0	23.75	PASS
Band5	3MHz	QPSK	20635	1RB#8	23.74	PASS
Band5	3MHz	QPSK	20635	1RB#14	23.63	PASS
Band5	3MHz	QPSK	20635	8RB#0	22.80	PASS
Band5	3MHz	QPSK	20635	8RB#4	22.78	PASS
Band5	3MHz	QPSK	20635	8RB#7	22.67	PASS
Band5	3MHz	QPSK	20635	15RB#0	22.74	PASS
Band5	3MHz	16QAM	20415	1RB#0	22.52	PASS
Band5	3MHz	16QAM	20415	1RB#8	22.53	PASS
Band5	3MHz	16QAM	20415	1RB#14	22.55	PASS
Band5	3MHz	16QAM	20415	8RB#0	21.84	PASS
Band5	3MHz	16QAM	20415	8RB#4	21.74	PASS
Band5	3MHz	16QAM	20415	8RB#7	21.62	PASS
Band5	3MHz	16QAM	20415	15RB#0	21.83	PASS
Band5	3MHz	16QAM	20525	1RB#0	22.72	PASS
Band5	3MHz	16QAM	20525	1RB#8	22.73	PASS
Band5	3MHz	16QAM	20525	1RB#14	22.75	PASS
Band5	3MHz	16QAM	20525	8RB#0	22.04	PASS
Band5	3MHz	16QAM	20525	8RB#4	21.94	PASS
Band5	3MHz	16QAM	20525	8RB#7	21.82	PASS



Band5	3MHz	16QAM	20525	15RB#0	22.03	PASS
Band5	3MHz	16QAM	20635	1RB#0	22.60	PASS
Band5	3MHz	16QAM	20635	1RB#8	22.61	PASS
Band5	3MHz	16QAM	20635	1RB#14	22.63	PASS
Band5	3MHz	16QAM	20635	8RB#0	21.93	PASS
Band5	3MHz	16QAM	20635	8RB#4	21.83	PASS
Band5	3MHz	16QAM	20635	8RB#7	21.71	PASS
Band5	3MHz	16QAM	20635	15RB#0	21.92	PASS
Band5	5MHz	QPSK	20425	1RB#0	23.64	PASS
Band5	5MHz	QPSK	20425	1RB#12	23.78	PASS
Band5	5MHz	QPSK	20425	1RB#24	23.57	PASS
Band5	5MHz	QPSK	20425	12RB#0	22.65	PASS
Band5	5MHz	QPSK	20425	12RB#6	22.65	PASS
Band5	5MHz	QPSK	20425	12RB#13	22.63	PASS
Band5	5MHz	QPSK	20425	25RB#0	22.65	PASS
Band5	5MHz	QPSK	20525	1RB#0	23.85	PASS
Band5	5MHz	QPSK	20525	1RB#12	24.00	PASS
Band5	5MHz	QPSK	20525	1RB#24	23.78	PASS
Band5	5MHz	QPSK	20525	12RB#0	22.86	PASS
Band5	5MHz	QPSK	20525	12RB#6	22.86	PASS
Band5	5MHz	QPSK	20525	12RB#13	22.83	PASS
Band5	5MHz	QPSK	20525	25RB#0	22.86	PASS
Band5	5MHz	QPSK	20625	1RB#0	23.73	PASS
Band5	5MHz	QPSK	20625	1RB#12	23.88	PASS
Band5	5MHz	QPSK	20625	1RB#24	23.66	PASS
Band5	5MHz	QPSK	20625	12RB#0	22.74	PASS
Band5	5MHz	QPSK	20625	12RB#6	22.74	PASS
Band5	5MHz	QPSK	20625	12RB#13	22.71	PASS
Band5	5MHz	QPSK	20625	25RB#0	22.74	PASS
Band5	5MHz	16QAM	20425	1RB#0	22.56	PASS
Band5	5MHz	16QAM	20425	1RB#12	22.81	PASS
Band5	5MHz	16QAM	20425	1RB#24	22.63	PASS
Band5	5MHz	16QAM	20425	12RB#0	21.82	PASS
Band5	5MHz	16QAM	20425	12RB#6	21.84	PASS
Band5	5MHz	16QAM	20425	12RB#13	21.76	PASS
Band5	5MHz	16QAM	20425	25RB#0	21.77	PASS
Band5	5MHz	16QAM	20525	1RB#0	22.76	PASS
Band5	5MHz	16QAM	20525	1RB#12	23.02	PASS
Band5	5MHz	16QAM	20525	1RB#24	22.84	PASS
Band5	5MHz	16QAM	20525	12RB#0	22.02	PASS
Band5	5MHz	16QAM	20525	12RB#6	22.04	PASS
Band5	5MHz	16QAM	20525	12RB#13	21.96	PASS
Band5	5MHz	16QAM	20525	25RB#0	21.97	PASS
Band5	5MHz	16QAM	20625	1RB#0	22.64	PASS
Band5	5MHz	16QAM	20625	1RB#12	22.90	PASS



Band5	5MHz	16QAM	20625	1RB#24	22.72	PASS
Band5	5MHz	16QAM	20625	12RB#0	21.91	PASS
Band5	5MHz	16QAM	20625	12RB#6	21.93	PASS
Band5	5MHz	16QAM	20625	12RB#13	21.85	PASS
Band5	5MHz	16QAM	20625	25RB#0	21.86	PASS
Band5	10MHz	QPSK	20450	1RB#0	23.57	PASS
Band5	10MHz	QPSK	20450	1RB#24	23.55	PASS
Band5	10MHz	QPSK	20450	1RB#49	23.58	PASS
Band5	10MHz	QPSK	20450	25RB#0	22.73	PASS
Band5	10MHz	QPSK	20450	25RB#12	22.71	PASS
Band5	10MHz	QPSK	20450	25RB#25	22.71	PASS
Band5	10MHz	QPSK	20450	50RB#0	22.64	PASS
Band5	10MHz	QPSK	20525	1RB#0	23.78	PASS
Band5	10MHz	QPSK	20525	1RB#24	23.76	PASS
Band5	10MHz	QPSK	20525	1RB#49	23.79	PASS
Band5	10MHz	QPSK	20525	25RB#0	22.94	PASS
Band5	10MHz	QPSK	20525	25RB#12	22.92	PASS
Band5	10MHz	QPSK	20525	25RB#25	22.92	PASS
Band5	10MHz	QPSK	20525	50RB#0	22.85	PASS
Band5	10MHz	QPSK	20600	1RB#0	23.66	PASS
Band5	10MHz	QPSK	20600	1RB#24	23.64	PASS
Band5	10MHz	QPSK	20600	1RB#49	23.67	PASS
Band5	10MHz	QPSK	20600	25RB#0	22.82	PASS
Band5	10MHz	QPSK	20600	25RB#12	22.80	PASS
Band5	10MHz	QPSK	20600	25RB#25	22.80	PASS
Band5	10MHz	QPSK	20600	50RB#0	22.73	PASS
Band5	10MHz	16QAM	20450	1RB#0	23.03	PASS
Band5	10MHz	16QAM	20450	1RB#24	23.24	PASS
Band5	10MHz	16QAM	20450	1RB#49	22.84	PASS
Band5	10MHz	16QAM	20450	25RB#0	21.79	PASS
Band5	10MHz	16QAM	20450	25RB#12	21.75	PASS
Band5	10MHz	16QAM	20450	25RB#25	21.69	PASS
Band5	10MHz	16QAM	20450	50RB#0	21.71	PASS
Band5	10MHz	16QAM	20525	1RB#0	23.24	PASS
Band5	10MHz	16QAM	20525	1RB#24	23.45	PASS
Band5	10MHz	16QAM	20525	1RB#49	23.05	PASS
Band5	10MHz	16QAM	20525	25RB#0	21.99	PASS
Band5	10MHz	16QAM	20525	25RB#12	21.95	PASS
Band5	10MHz	16QAM	20525	25RB#25	21.89	PASS
Band5	10MHz	16QAM	20525	50RB#0	21.91	PASS
Band5	10MHz	16QAM	20600	1RB#0	23.12	PASS
Band5	10MHz	16QAM	20600	1RB#24	23.33	PASS
Band5	10MHz	16QAM	20600	1RB#49	22.93	PASS
Band5	10MHz	16QAM	20600	25RB#0	21.88	PASS
Band5	10MHz	16QAM	20600	25RB#12	21.84	PASS



Band5	10MHz	16QAM	20600	25RB#25	21.78	PASS
Band5	10MHz	16QAM	20600	50RB#0	21.80	PASS
Band13	5MHz	QPSK	23205	1RB#0	23.99	PASS
Band13	5MHz	QPSK	23205	1RB#12	24.55	PASS
Band13	5MHz	QPSK	23205	1RB#24	24.18	PASS
Band13	5MHz	QPSK	23205	12RB#0	23.08	PASS
Band13	5MHz	QPSK	23205	12RB#6	23.29	PASS
Band13	5MHz	QPSK	23205	12RB#13	23.26	PASS
Band13	5MHz	QPSK	23205	25RB#0	23.24	PASS
Band13	5MHz	QPSK	23230	1RB#0	24.21	PASS
Band13	5MHz	QPSK	23230	1RB#12	24.77	PASS
Band13	5MHz	QPSK	23230	1RB#24	24.40	PASS
Band13	5MHz	QPSK	23230	12RB#0	23.29	PASS
Band13	5MHz	QPSK	23230	12RB#6	23.50	PASS
Band13	5MHz	QPSK	23230	12RB#13	23.47	PASS
Band13	5MHz	QPSK	23230	25RB#0	23.45	PASS
Band13	5MHz	QPSK	23255	1RB#0	24.09	PASS
Band13	5MHz	QPSK	23255	1RB#12	24.64	PASS
Band13	5MHz	QPSK	23255	1RB#24	24.28	PASS
Band13	5MHz	QPSK	23255	12RB#0	23.17	PASS
Band13	5MHz	QPSK	23255	12RB#6	23.38	PASS
Band13	5MHz	QPSK	23255	12RB#13	23.35	PASS
Band13	5MHz	QPSK	23255	25RB#0	23.33	PASS
Band13	5MHz	16QAM	23205	1RB#0	22.85	PASS
Band13	5MHz	16QAM	23205	1RB#12	23.26	PASS
Band13	5MHz	16QAM	23205	1RB#24	23.04	PASS
Band13	5MHz	16QAM	23205	12RB#0	22.30	PASS
Band13	5MHz	16QAM	23205	12RB#6	22.30	PASS
Band13	5MHz	16QAM	23205	12RB#13	22.37	PASS
Band13	5MHz	16QAM	23205	25RB#0	22.39	PASS
Band13	5MHz	16QAM	23230	1RB#0	23.06	PASS
Band13	5MHz	16QAM	23230	1RB#12	23.47	PASS
Band13	5MHz	16QAM	23230	1RB#24	23.25	PASS
Band13	5MHz	16QAM	23230	12RB#0	22.50	PASS
Band13	5MHz	16QAM	23230	12RB#6	22.50	PASS
Band13	5MHz	16QAM	23230	12RB#13	22.57	PASS
Band13	5MHz	16QAM	23230	25RB#0	22.59	PASS
Band13	5MHz	16QAM	23255	1RB#0	22.94	PASS
Band13	5MHz	16QAM	23255	1RB#12	23.35	PASS
Band13	5MHz	16QAM	23255	1RB#24	23.13	PASS
Band13	5MHz	16QAM	23255	12RB#0	22.39	PASS
Band13	5MHz	16QAM	23255	12RB#6	22.39	PASS
Band13	5MHz	16QAM	23255	12RB#13	22.45	PASS
Band13	5MHz	16QAM	23255	25RB#0	22.47	PASS
Band13	10MHz	QPSK	23230	1RB#0	24.16	PASS



Band13	10MHz	QPSK	23230	1RB#24	24.62	PASS
Band13	10MHz	QPSK	23230	1RB#49	24.58	PASS
Band13	10MHz	QPSK	23230	25RB#0	23.46	PASS
Band13	10MHz	QPSK	23230	25RB#12	23.50	PASS
Band13	10MHz	QPSK	23230	25RB#25	23.45	PASS
Band13	10MHz	QPSK	23230	50RB#0	23.50	PASS
Band13	10MHz	16QAM	23230	1RB#0	23.46	PASS
Band13	10MHz	16QAM	23230	1RB#24	24.05	PASS
Band13	10MHz	16QAM	23230	1RB#49	23.73	PASS
Band13	10MHz	16QAM	23230	25RB#0	22.54	PASS
Band13	10MHz	16QAM	23230	25RB#12	22.36	PASS
Band13	10MHz	16QAM	23230	25RB#25	22.37	PASS
Band13	10MHz	16QAM	23230	50RB#0	22.43	PASS



8.2 Appendix B: Peak-to-Average Ratio(CCDF)

Test Result

Band	Bandwidth	Modulation	Channel	RB Configuration	Result(dB)	Limit(dB)	Verdict
Band2	1.4MHz	QPSK	18607	1RB#0	4.55	13	PASS
Band2	1.4MHz	QPSK	18607	6RB#0	5.21	13	PASS
Band2	1.4MHz	QPSK	18900	1RB#0	4.83	13	PASS
Band2	1.4MHz	QPSK	18900	6RB#0	5.34	13	PASS
Band2	1.4MHz	QPSK	19193	1RB#0	4.65	13	PASS
Band2	1.4MHz	QPSK	19193	6RB#0	4.89	13	PASS
Band2	1.4MHz	16QAM	18607	1RB#0	5.52	13	PASS
Band2	1.4MHz	16QAM	18607	6RB#0	6.12	13	PASS
Band2	1.4MHz	16QAM	18900	1RB#0	5.66	13	PASS
Band2	1.4MHz	16QAM	18900	6RB#0	6.25	13	PASS
Band2	1.4MHz	16QAM	19193	1RB#0	5.47	13	PASS
Band2	1.4MHz	16QAM	19193	6RB#0	5.77	13	PASS
Band2	3MHz	QPSK	18615	1RB#0	4.67	13	PASS
Band2	3MHz	QPSK	18615	15RB#0	5.24	13	PASS
Band2	3MHz	QPSK	18900	1RB#0	4.83	13	PASS
Band2	3MHz	QPSK	18900	15RB#0	5.41	13	PASS
Band2	3MHz	QPSK	19185	1RB#0	4.71	13	PASS
Band2	3MHz	QPSK	19185	15RB#0	4.94	13	PASS
Band2	3MHz	16QAM	18615	1RB#0	5.48	13	PASS
Band2	3MHz	16QAM	18615	15RB#0	6.19	13	PASS
Band2	3MHz	16QAM	18900	1RB#0	5.70	13	PASS
Band2	3MHz	16QAM	18900	15RB#0	6.30	13	PASS
Band2	3MHz	16QAM	19185	1RB#0	5.50	13	PASS
Band2	3MHz	16QAM	19185	15RB#0	5.85	13	PASS
Band2	5MHz	QPSK	18625	1RB#0	4.61	13	PASS
Band2	5MHz	QPSK	18625	25RB#0	5.18	13	PASS
Band2	5MHz	QPSK	18900	1RB#0	4.86	13	PASS
Band2	5MHz	QPSK	18900	25RB#0	5.32	13	PASS
Band2	5MHz	QPSK	19175	1RB#0	4.65	13	PASS
Band2	5MHz	QPSK	19175	25RB#0	4.96	13	PASS
Band2	5MHz	16QAM	18625	1RB#0	5.53	13	PASS
Band2	5MHz	16QAM	18625	25RB#0	6.08	13	PASS
Band2	5MHz	16QAM	18900	1RB#0	5.60	13	PASS
Band2	5MHz	16QAM	18900	25RB#0	6.18	13	PASS
Band2	5MHz	16QAM	19175	1RB#0	5.40	13	PASS
Band2	5MHz	16QAM	19175	25RB#0	5.79	13	PASS
Band2	10MHz	QPSK	18650	1RB#0	4.60	13	PASS
Band2	10MHz	QPSK	18650	50RB#0	5.26	13	PASS
Band2	10MHz	QPSK	18900	1RB#0	4.85	13	PASS
Band2	10MHz	QPSK	18900	50RB#0	5.42	13	PASS



Band2	10MHz	QPSK	19150	1RB#0	4.16	13	PASS
Band2	10MHz	QPSK	19150	50RB#0	5.21	13	PASS
Band2	10MHz	16QAM	18650	1RB#0	5.45	13	PASS
Band2	10MHz	16QAM	18650	50RB#0	6.12	13	PASS
Band2	10MHz	16QAM	18900	1RB#0	5.83	13	PASS
Band2	10MHz	16QAM	18900	50RB#0	6.29	13	PASS
Band2	10MHz	16QAM	19150	1RB#0	4.90	13	PASS
Band2	10MHz	16QAM	19150	50RB#0	6.07	13	PASS
Band2	15MHz	QPSK	18675	1RB#0	4.59	13	PASS
Band2	15MHz	QPSK	18675	75RB#0	5.23	13	PASS
Band2	15MHz	QPSK	18900	1RB#0	4.84	13	PASS
Band2	15MHz	QPSK	18900	75RB#0	5.57	13	PASS
Band2	15MHz	QPSK	19125	1RB#0	4.03	13	PASS
Band2	15MHz	QPSK	19125	75RB#0	5.29	13	PASS
Band2	15MHz	16QAM	18675	1RB#0	5.42	13	PASS
Band2	15MHz	16QAM	18675	75RB#0	6.13	13	PASS
Band2	15MHz	16QAM	18900	1RB#0	5.74	13	PASS
Band2	15MHz	16QAM	18900	75RB#0	6.32	13	PASS
Band2	15MHz	16QAM	19125	1RB#0	4.88	13	PASS
Band2	15MHz	16QAM	19125	75RB#0	6.09	13	PASS
Band2	20MHz	QPSK	18700	1RB#0	4.57	13	PASS
Band2	20MHz	QPSK	18700	100RB#0	5.07	13	PASS
Band2	20MHz	QPSK	18900	1RB#0	4.77	13	PASS
Band2	20MHz	QPSK	18900	100RB#0	5.43	13	PASS
Band2	20MHz	QPSK	19100	1RB#0	4.44	13	PASS
Band2	20MHz	QPSK	19100	100RB#0	4.96	13	PASS
Band2	20MHz	16QAM	18700	1RB#0	5.44	13	PASS
Band2	20MHz	16QAM	18700	100RB#0	6.04	13	PASS
Band2	20MHz	16QAM	18900	1RB#0	5.82	13	PASS
Band2	20MHz	16QAM	18900	100RB#0	6.27	13	PASS
Band2	20MHz	16QAM	19100	1RB#0	5.16	13	PASS
Band2	20MHz	16QAM	19100	100RB#0	5.89	13	PASS
Band4	1.4MHz	QPSK	19957	1RB#0	4.18	13	PASS
Band4	1.4MHz	QPSK	19957	6RB#0	4.83	13	PASS
Band4	1.4MHz	QPSK	20175	1RB#0	4.70	13	PASS
Band4	1.4MHz	QPSK	20175	6RB#0	5.17	13	PASS
Band4	1.4MHz	QPSK	20393	1RB#0	3.94	13	PASS
Band4	1.4MHz	QPSK	20393	6RB#0	4.76	13	PASS
Band4	1.4MHz	16QAM	19957	1RB#0	5.06	13	PASS
Band4	1.4MHz	16QAM	19957	6RB#0	5.87	13	PASS
Band4	1.4MHz	16QAM	20175	1RB#0	5.56	13	PASS
Band4	1.4MHz	16QAM	20175	6RB#0	6.13	13	PASS
Band4	1.4MHz	16QAM	20393	1RB#0	4.84	13	PASS
Band4	1.4MHz	16QAM	20393	6RB#0	5.72	13	PASS
Band4	3MHz	QPSK	19965	1RB#0	4.22	13	PASS



Band4	3MHz	QPSK	19965	15RB#0	4.76	13	PASS
Band4	3MHz	QPSK	20175	1RB#0	4.73	13	PASS
Band4	3MHz	QPSK	20175	15RB#0	5.28	13	PASS
Band4	3MHz	QPSK	20385	1RB#0	3.78	13	PASS
Band4	3MHz	QPSK	20385	15RB#0	4.69	13	PASS
Band4	3MHz	16QAM	19965	1RB#0	4.95	13	PASS
Band4	3MHz	16QAM	19965	15RB#0	5.81	13	PASS
Band4	3MHz	16QAM	20175	1RB#0	5.55	13	PASS
Band4	3MHz	16QAM	20175	15RB#0	6.14	13	PASS
Band4	3MHz	16QAM	20385	1RB#0	4.99	13	PASS
Band4	3MHz	16QAM	20385	15RB#0	5.64	13	PASS
Band4	5MHz	QPSK	19975	1RB#0	4.20	13	PASS
Band4	5MHz	QPSK	19975	25RB#0	4.72	13	PASS
Band4	5MHz	QPSK	20175	1RB#0	4.70	13	PASS
Band4	5MHz	QPSK	20175	25RB#0	5.20	13	PASS
Band4	5MHz	QPSK	20375	1RB#0	3.74	13	PASS
Band4	5MHz	QPSK	20375	25RB#0	4.50	13	PASS
Band4	5MHz	16QAM	19975	1RB#0	5.16	13	PASS
Band4	5MHz	16QAM	19975	25RB#0	5.70	13	PASS
Band4	5MHz	16QAM	20175	1RB#0	5.53	13	PASS
Band4	5MHz	16QAM	20175	25RB#0	6.08	13	PASS
Band4	5MHz	16QAM	20375	1RB#0	4.63	13	PASS
Band4	5MHz	16QAM	20375	25RB#0	5.35	13	PASS
Band4	10MHz	QPSK	20000	1RB#0	4.08	13	PASS
Band4	10MHz	QPSK	20000	50RB#0	4.77	13	PASS
Band4	10MHz	QPSK	20175	1RB#0	4.63	13	PASS
Band4	10MHz	QPSK	20175	50RB#0	5.29	13	PASS
Band4	10MHz	QPSK	20350	1RB#0	3.76	13	PASS
Band4	10MHz	QPSK	20350	50RB#0	4.58	13	PASS
Band4	10MHz	16QAM	20000	1RB#0	4.99	13	PASS
Band4	10MHz	16QAM	20000	50RB#0	5.67	13	PASS
Band4	10MHz	16QAM	20175	1RB#0	5.46	13	PASS
Band4	10MHz	16QAM	20175	50RB#0	6.11	13	PASS
Band4	10MHz	16QAM	20350	1RB#0	4.86	13	PASS
Band4	10MHz	16QAM	20350	50RB#0	5.49	13	PASS
Band4	15MHz	QPSK	20025	1RB#0	3.92	13	PASS
Band4	15MHz	QPSK	20025	75RB#0	4.74	13	PASS
Band4	15MHz	QPSK	20175	1RB#0	4.45	13	PASS
Band4	15MHz	QPSK	20175	75RB#0	5.37	13	PASS
Band4	15MHz	QPSK	20325	1RB#0	4.02	13	PASS
Band4	15MHz	QPSK	20325	75RB#0	4.62	13	PASS
Band4	15MHz	16QAM	20025	1RB#0	4.57	13	PASS
Band4	15MHz	16QAM	20025	75RB#0	5.56	13	PASS
Band4	15MHz	16QAM	20175	1RB#0	5.38	13	PASS
Band4	15MHz	16QAM	20175	75RB#0	6.17	13	PASS



Band4	15MHz	16QAM	20325	1RB#0	4.74	13	PASS
Band4	15MHz	16QAM	20325	75RB#0	5.54	13	PASS
Band4	20MHz	QPSK	20050	1RB#0	3.90	13	PASS
Band4	20MHz	QPSK	20050	100RB#0	4.89	13	PASS
Band4	20MHz	QPSK	20175	1RB#0	4.13	13	PASS
Band4	20MHz	QPSK	20175	100RB#0	5.19	13	PASS
Band4	20MHz	QPSK	20300	1RB#0	4.48	13	PASS
Band4	20MHz	QPSK	20300	100RB#0	4.62	13	PASS
Band4	20MHz	16QAM	20050	1RB#0	4.65	13	PASS
Band4	20MHz	16QAM	20050	100RB#0	5.73	13	PASS
Band4	20MHz	16QAM	20175	1RB#0	4.90	13	PASS
Band4	20MHz	16QAM	20175	100RB#0	6.11	13	PASS
Band4	20MHz	16QAM	20300	1RB#0	5.26	13	PASS
Band4	20MHz	16QAM	20300	100RB#0	5.59	13	PASS
Band5	1.4MHz	QPSK	20407	1RB#0	4.74	13	PASS
Band5	1.4MHz	QPSK	20407	6RB#0	5.36	13	PASS
Band5	1.4MHz	QPSK	20525	1RB#0	4.77	13	PASS
Band5	1.4MHz	QPSK	20525	6RB#0	5.34	13	PASS
Band5	1.4MHz	QPSK	20643	1RB#0	4.74	13	PASS
Band5	1.4MHz	QPSK	20643	6RB#0	5.21	13	PASS
Band5	1.4MHz	16QAM	20407	1RB#0	5.58	13	PASS
Band5	1.4MHz	16QAM	20407	6RB#0	6.23	13	PASS
Band5	1.4MHz	16QAM	20525	1RB#0	5.55	13	PASS
Band5	1.4MHz	16QAM	20525	6RB#0	6.23	13	PASS
Band5	1.4MHz	16QAM	20643	1RB#0	5.57	13	PASS
Band5	1.4MHz	16QAM	20643	6RB#0	6.11	13	PASS
Band5	3MHz	QPSK	20415	1RB#0	4.78	13	PASS
Band5	3MHz	QPSK	20415	15RB#0	5.44	13	PASS
Band5	3MHz	QPSK	20525	1RB#0	4.79	13	PASS
Band5	3MHz	QPSK	20525	15RB#0	5.37	13	PASS
Band5	3MHz	QPSK	20635	1RB#0	4.74	13	PASS
Band5	3MHz	QPSK	20635	15RB#0	5.28	13	PASS
Band5	3MHz	16QAM	20415	1RB#0	5.60	13	PASS
Band5	3MHz	16QAM	20415	15RB#0	6.22	13	PASS
Band5	3MHz	16QAM	20525	1RB#0	5.71	13	PASS
Band5	3MHz	16QAM	20525	15RB#0	6.22	13	PASS
Band5	3MHz	16QAM	20635	1RB#0	5.47	13	PASS
Band5	3MHz	16QAM	20635	15RB#0	6.21	13	PASS
Band5	5MHz	QPSK	20425	1RB#0	4.71	13	PASS
Band5	5MHz	QPSK	20425	25RB#0	5.33	13	PASS
Band5	5MHz	QPSK	20525	1RB#0	4.72	13	PASS
Band5	5MHz	QPSK	20525	25RB#0	5.30	13	PASS
Band5	5MHz	QPSK	20625	1RB#0	4.64	13	PASS
Band5	5MHz	QPSK	20625	25RB#0	5.21	13	PASS
Band5	5MHz	16QAM	20425	1RB#0	5.49	13	PASS



Band5	5MHz	16QAM	20425	25RB#0	6.10	13	PASS
Band5	5MHz	16QAM	20525	1RB#0	5.64	13	PASS
Band5	5MHz	16QAM	20525	25RB#0	6.14	13	PASS
Band5	5MHz	16QAM	20625	1RB#0	5.41	13	PASS
Band5	5MHz	16QAM	20625	25RB#0	6.02	13	PASS
Band5	10MHz	QPSK	20450	1RB#0	4.71	13	PASS
Band5	10MHz	QPSK	20450	50RB#0	5.30	13	PASS
Band5	10MHz	QPSK	20525	1RB#0	4.68	13	PASS
Band5	10MHz	QPSK	20525	50RB#0	5.44	13	PASS
Band5	10MHz	QPSK	20600	1RB#0	4.65	13	PASS
Band5	10MHz	QPSK	20600	50RB#0	5.28	13	PASS
Band5	10MHz	16QAM	20450	1RB#0	5.56	13	PASS
Band5	10MHz	16QAM	20450	50RB#0	6.14	13	PASS
Band5	10MHz	16QAM	20525	1RB#0	5.53	13	PASS
Band5	10MHz	16QAM	20525	50RB#0	6.22	13	PASS
Band5	10MHz	16QAM	20600	1RB#0	5.59	13	PASS
Band5	10MHz	16QAM	20600	50RB#0	6.09	13	PASS
Band13	5MHz	QPSK	23205	1RB#0	4.35	13	PASS
Band13	5MHz	QPSK	23205	25RB#0	5.17	13	PASS
Band13	5MHz	QPSK	23230	1RB#0	4.47	13	PASS
Band13	5MHz	QPSK	23230	25RB#0	5.12	13	PASS
Band13	5MHz	QPSK	23255	1RB#0	4.57	13	PASS
Band13	5MHz	QPSK	23255	25RB#0	4.88	13	PASS
Band13	5MHz	16QAM	23205	1RB#0	5.14	13	PASS
Band13	5MHz	16QAM	23205	25RB#0	5.96	13	PASS
Band13	5MHz	16QAM	23230	1RB#0	5.37	13	PASS
Band13	5MHz	16QAM	23230	25RB#0	5.90	13	PASS
Band13	5MHz	16QAM	23255	1RB#0	5.32	13	PASS
Band13	5MHz	16QAM	23255	25RB#0	5.77	13	PASS
Band13	10MHz	QPSK	23230	1RB#0	4.35	13	PASS
Band13	10MHz	QPSK	23230	50RB#0	5.35	13	PASS
Band13	10MHz	16QAM	23230	1RB#0	5.22	13	PASS
Band13	10MHz	16QAM	23230	50RB#0	6.08	13	PASS



Test Graphs



Band2_1.4MHz_QPSK_18607_1RB#0

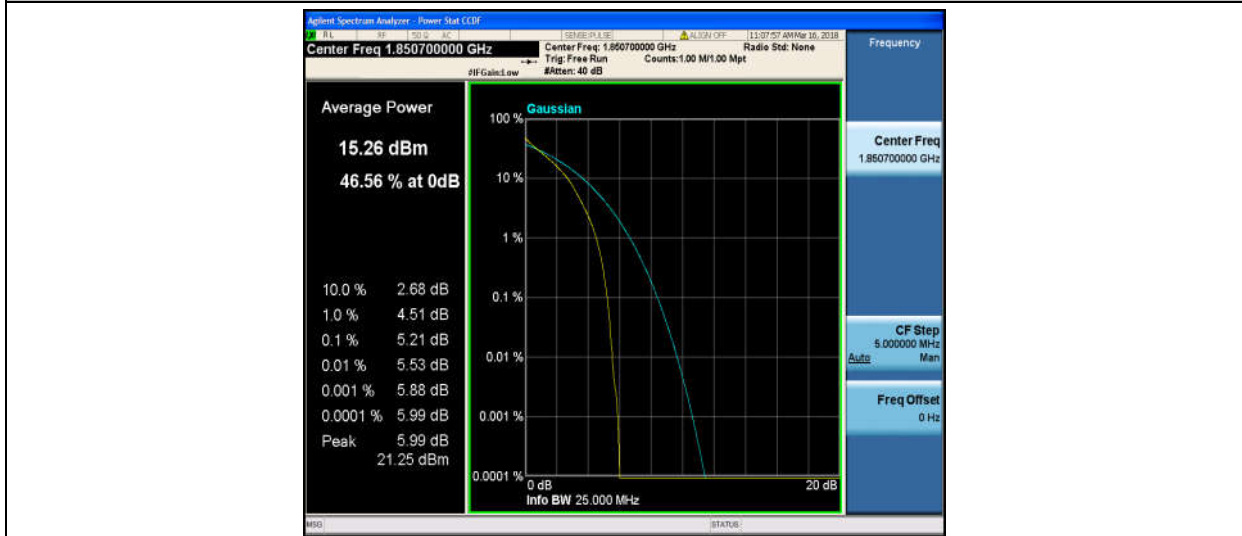

Band2_1.4MHz_QPSK_18607_6RB#0

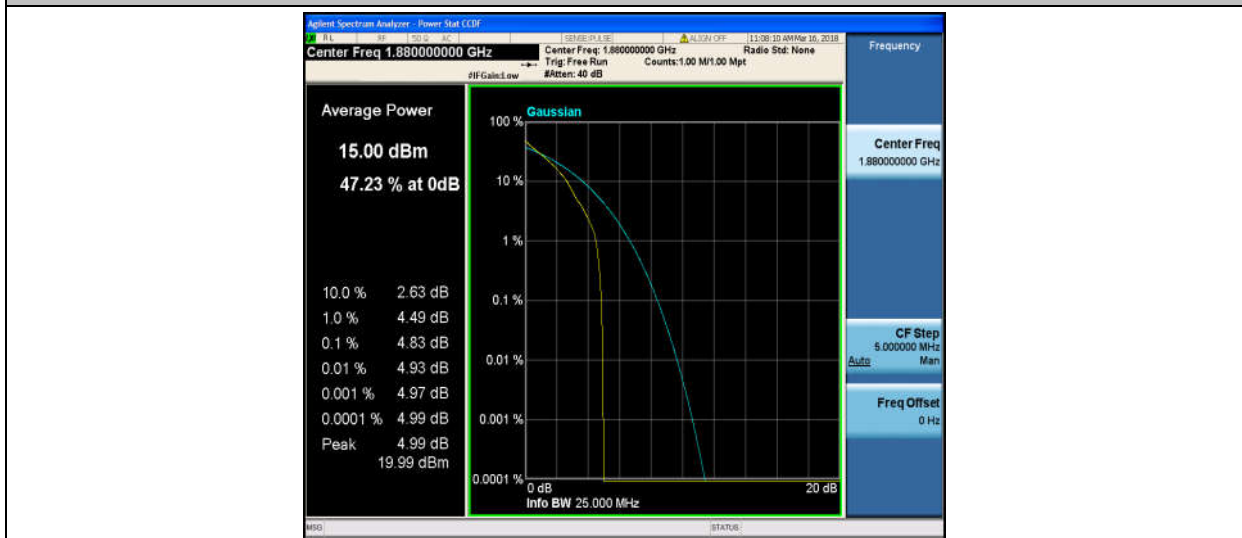

Band2_1.4MHz_QPSK_18900_1RB#0

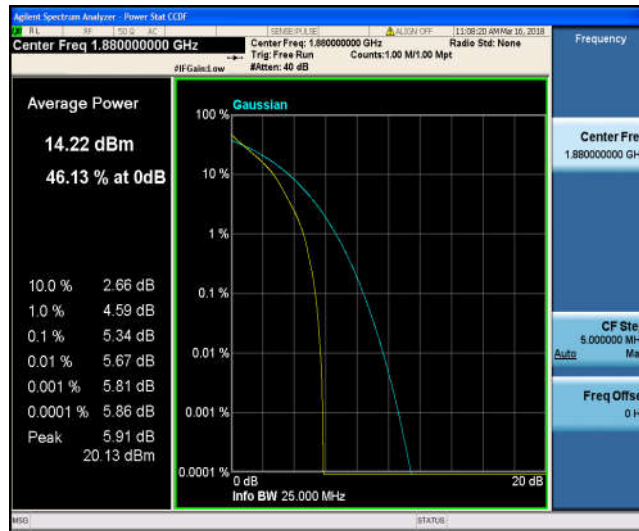

Band2_1.4MHz_QPSK_18900_6RB#0

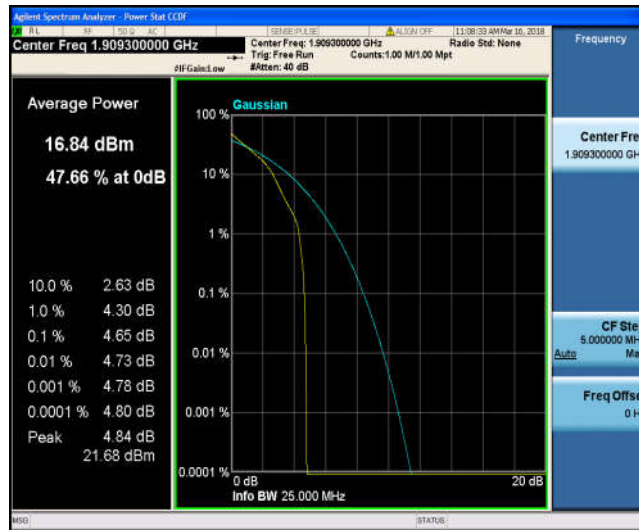

Band2_1.4MHz_QPSK_19193_1RB#0

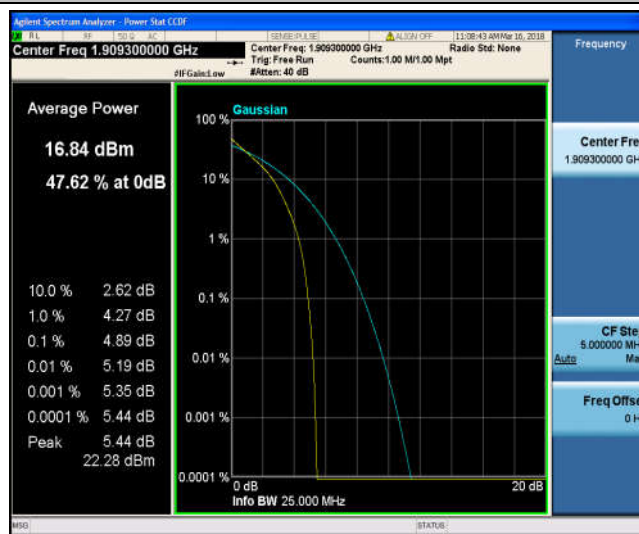

Band2_1.4MHz_QPSK_19193_6RB#0

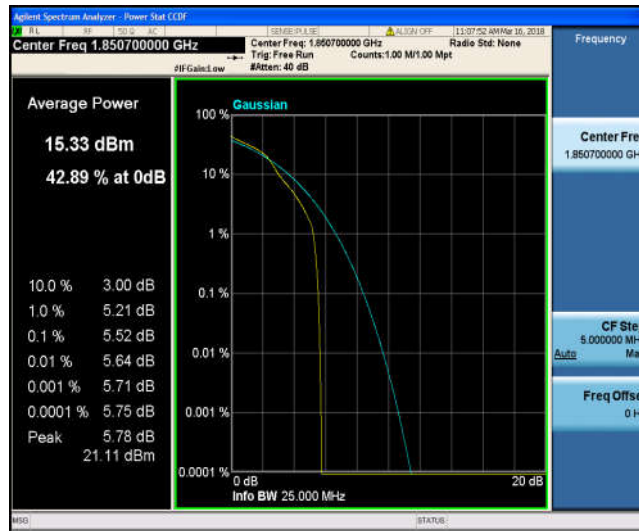

Band2_1.4MHz_16QAM_18607_1RB#0



Band2_1.4MHz_16QAM_18607_6RB#0

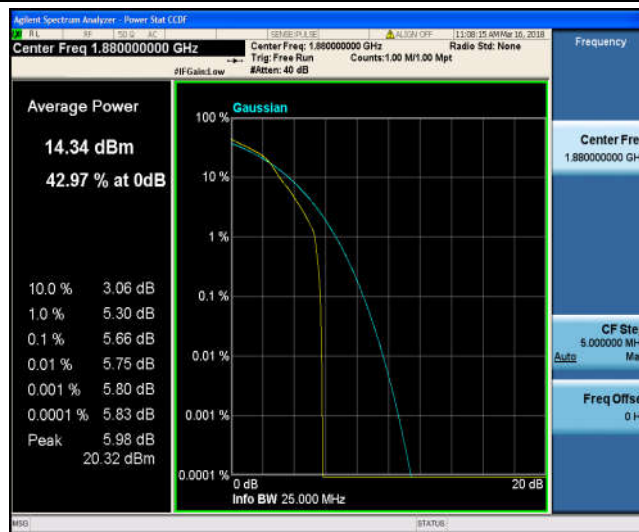

Band2_1.4MHz_16QAM_18900_1RB#0

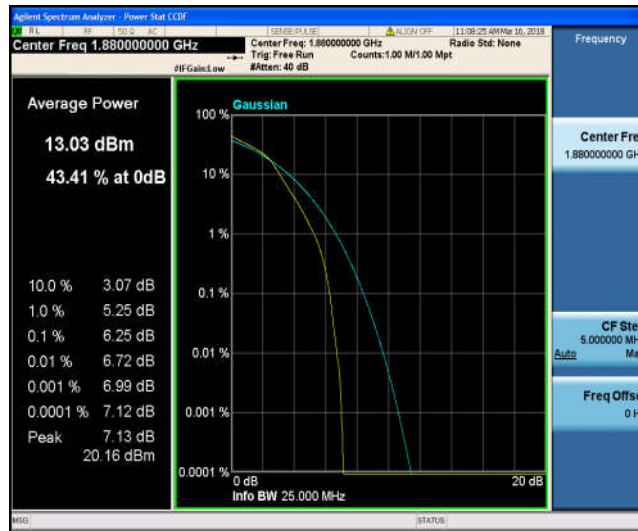

Band2_1.4MHz_16QAM_18900_6RB#0



Band2_1.4MHz_16QAM_19193_1RB#0

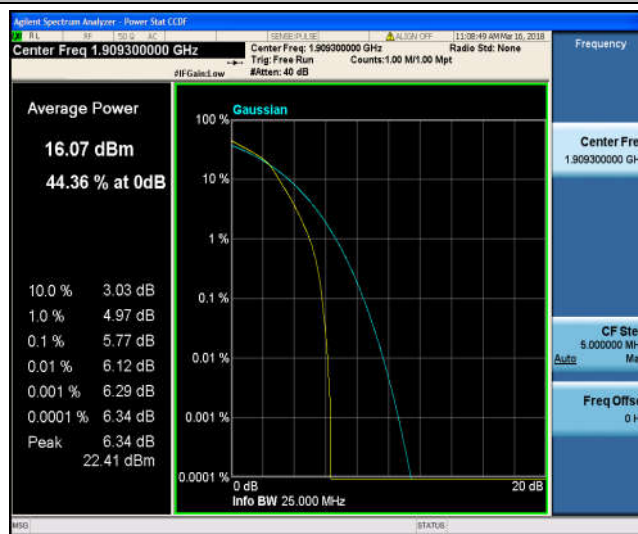

Band2_1.4MHz_16QAM_19193_6RB#0



Band2_3MHz_QPSK_18615_1RB#0

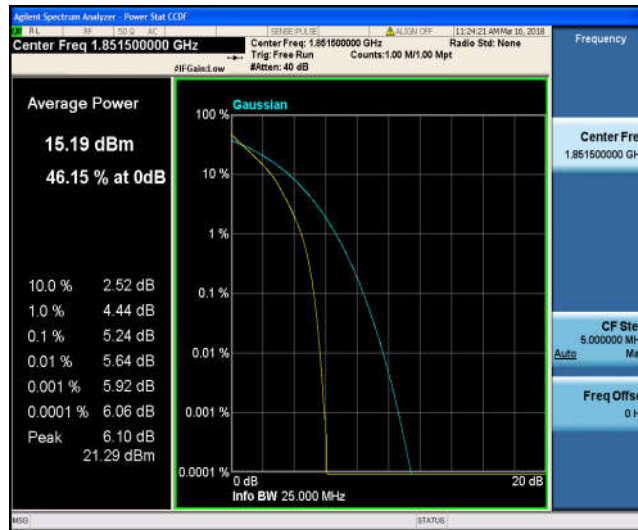

Band2_3MHz_QPSK_18615_15RB#0

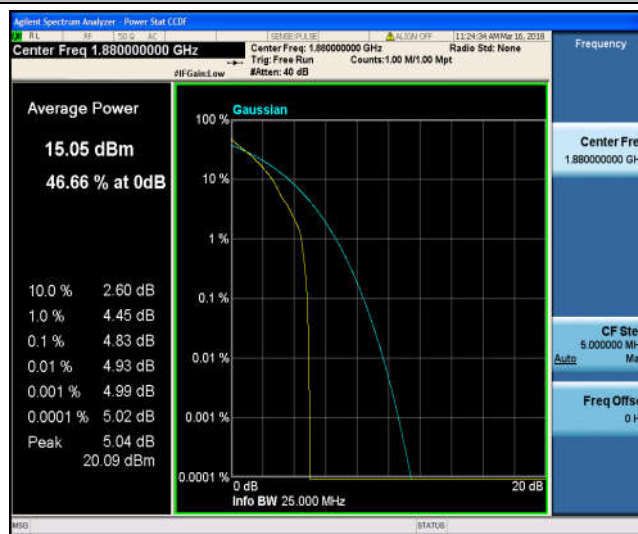

Band2_3MHz_QPSK_18900_1RB#0

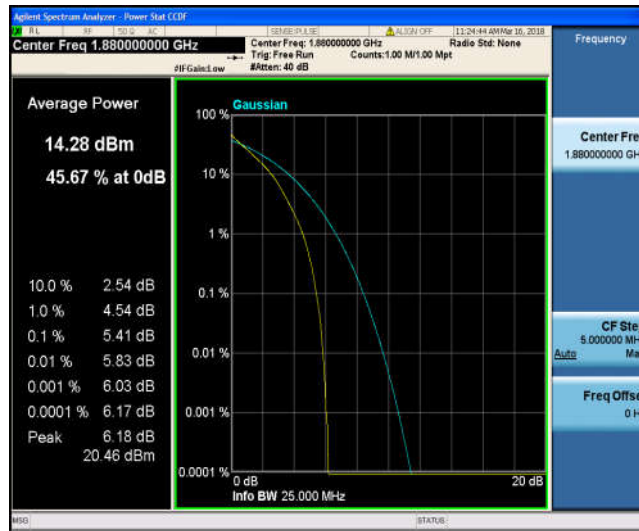

Band2_3MHz_QPSK_18900_15RB#0



Band2_3MHz_QPSK_19185_1RB#0



Band2_3MHz_QPSK_19185_15RB#0

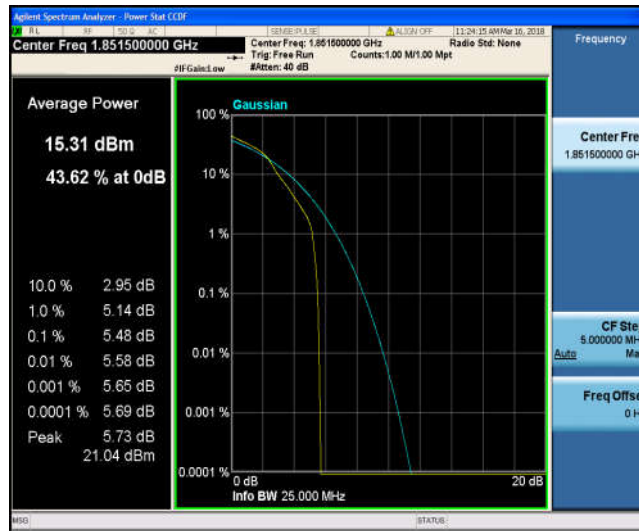

Band2_3MHz_16QAM_18615_1RB#0

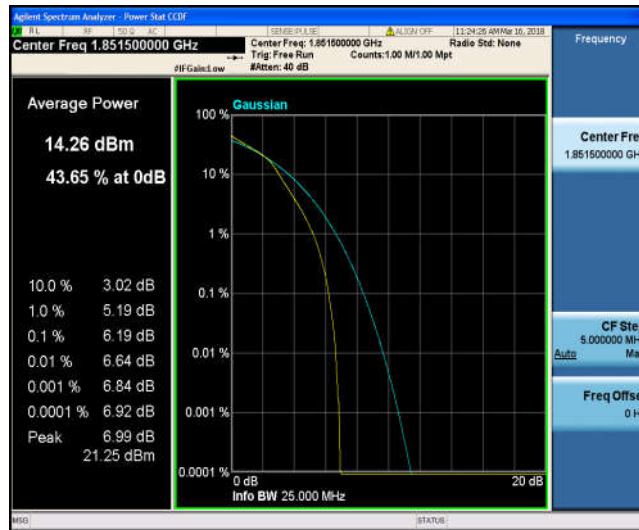

Band2_3MHz_16QAM_18615_15RB#0

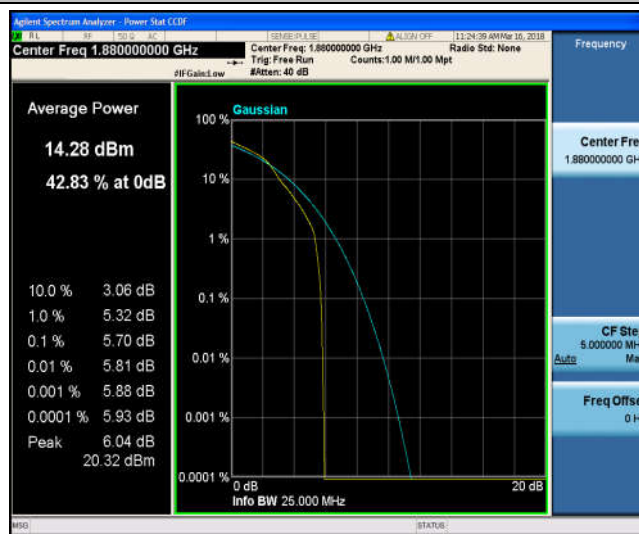

Band2_3MHz_16QAM_18900_1RB#0



Band2_3MHz_16QAM_18900_15RB#0



Band2_3MHz_16QAM_19185_1RB#0

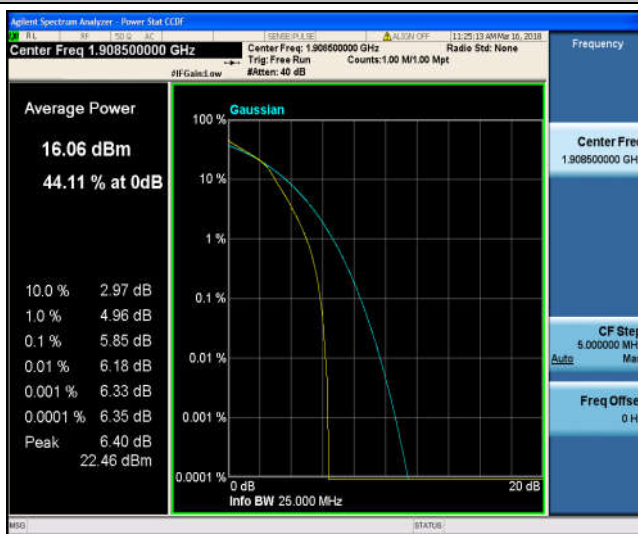

Band2_3MHz_16QAM_19185_15RB#0

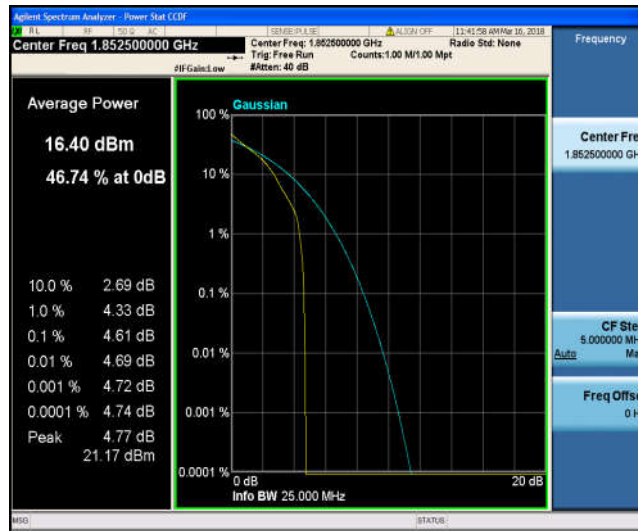

Band2_5MHz_QPSK_18625_1RB#0

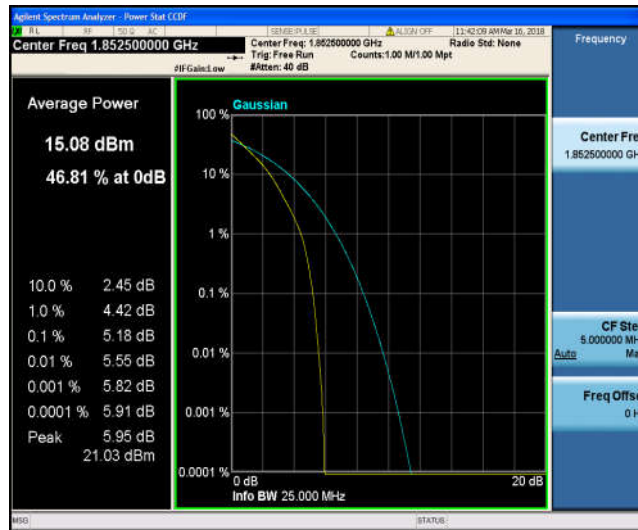

Band2_5MHz_QPSK_18625_25RB#0

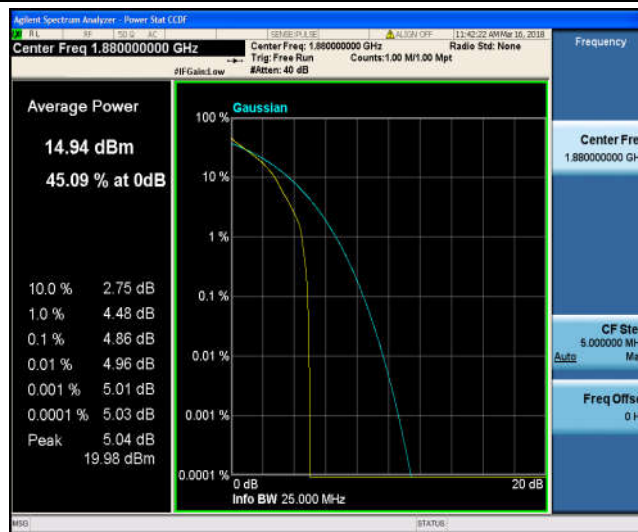

Band2_5MHz_QPSK_18900_1RB#0

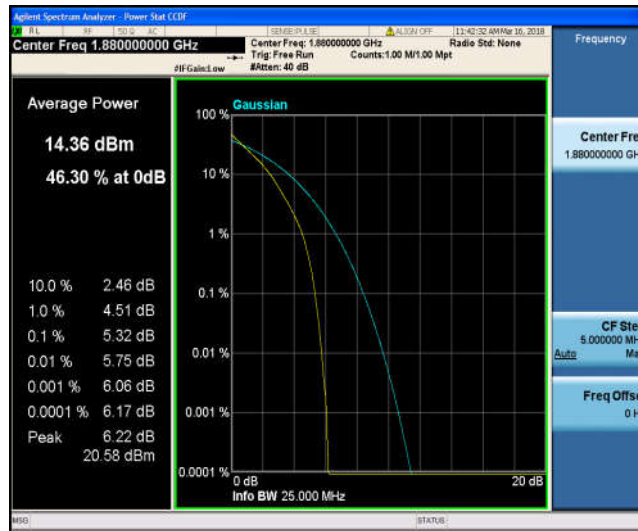

Band2_5MHz_QPSK_18900_25RB#0



Band2_5MHz_QPSK_19175_1RB#0

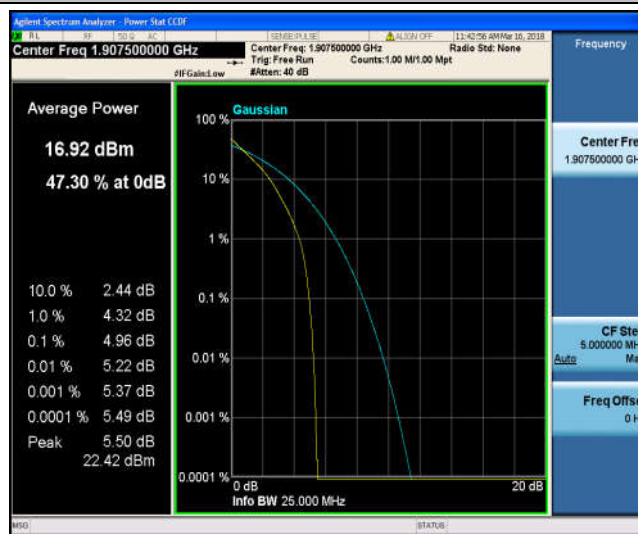

Band2_5MHz_QPSK_19175_25RB#0

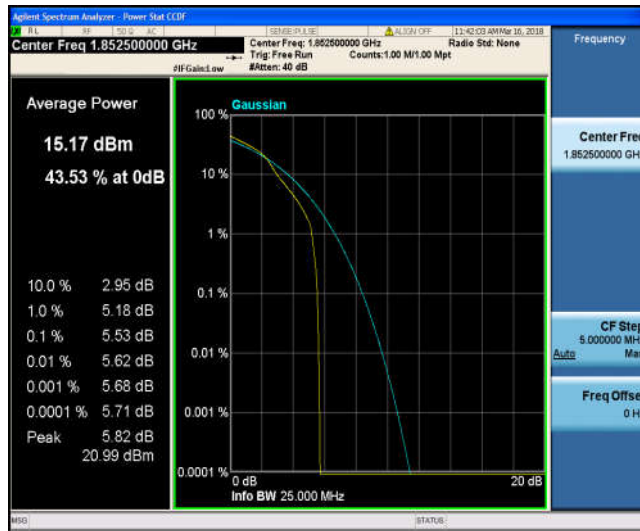

Band2_5MHz_16QAM_18625_1RB#0

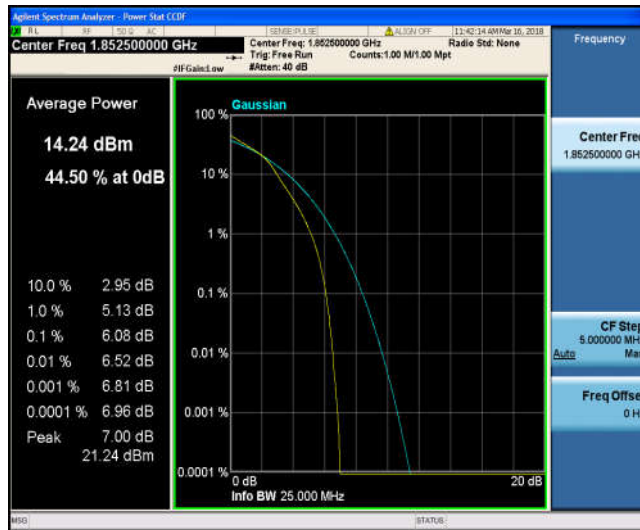

Band2_5MHz_16QAM_18625_25RB#0

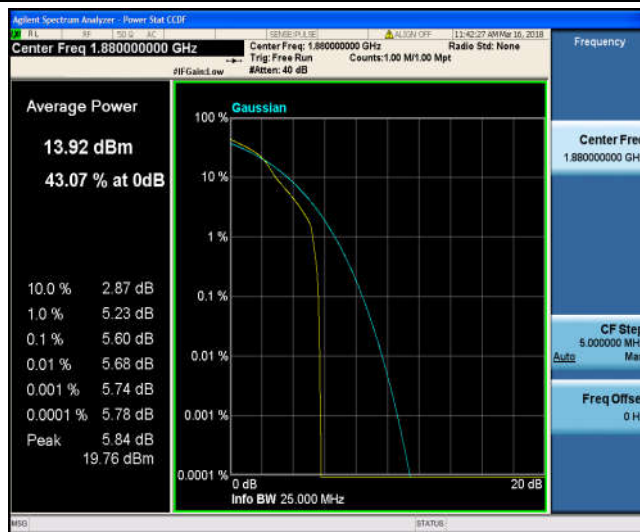

Band2_5MHz_16QAM_18900_1RB#0

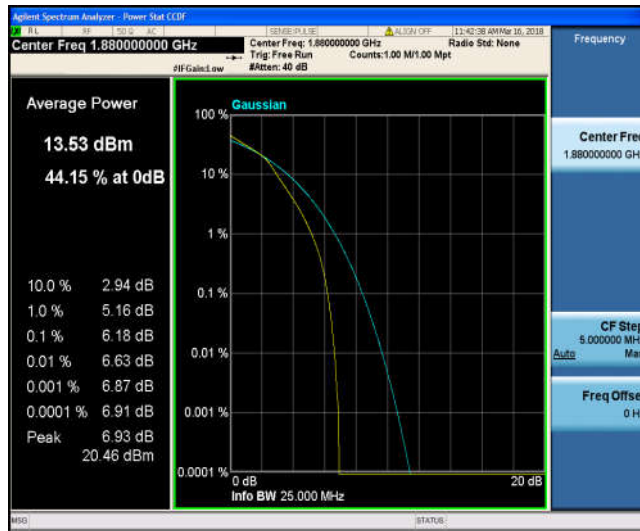

Band2_5MHz_16QAM_18900_25RB#0



Band2_5MHz_16QAM_19175_1RB#0



Band2_5MHz_16QAM_19175_25RB#0

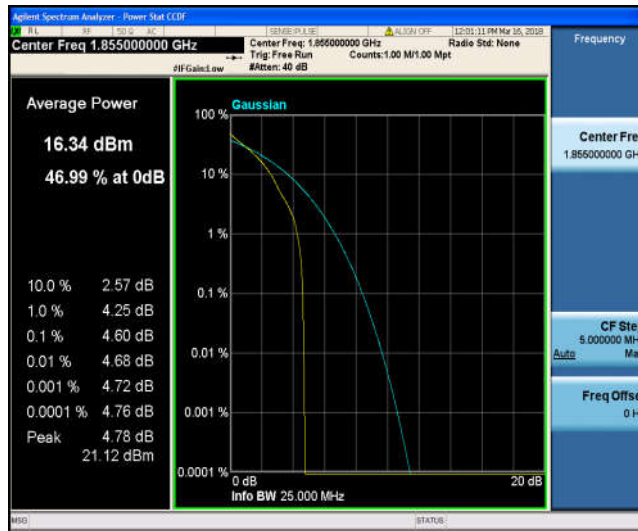

Band2_10MHz_QPSK_18650_1RB#0



Band2_10MHz_QPSK_18650_50RB#0

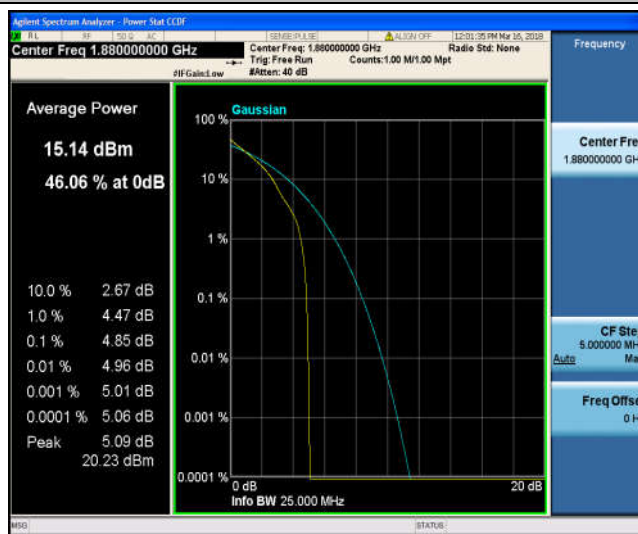

Band2_10MHz_QPSK_18900_1RB#0

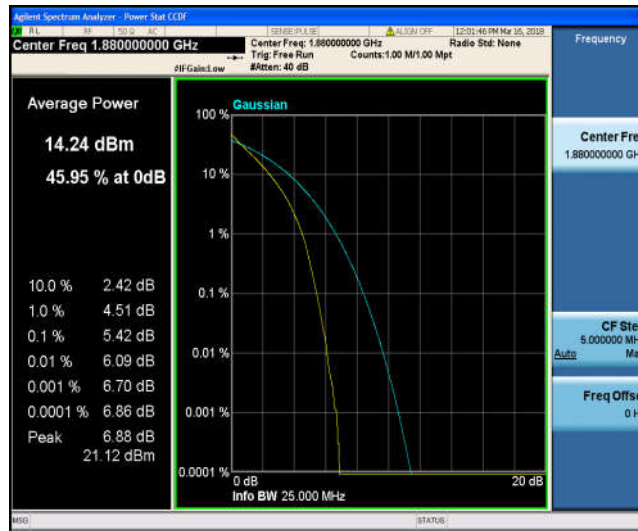

Band2_10MHz_QPSK_18900_50RB#0



Band2_10MHz_QPSK_19150_1RB#0

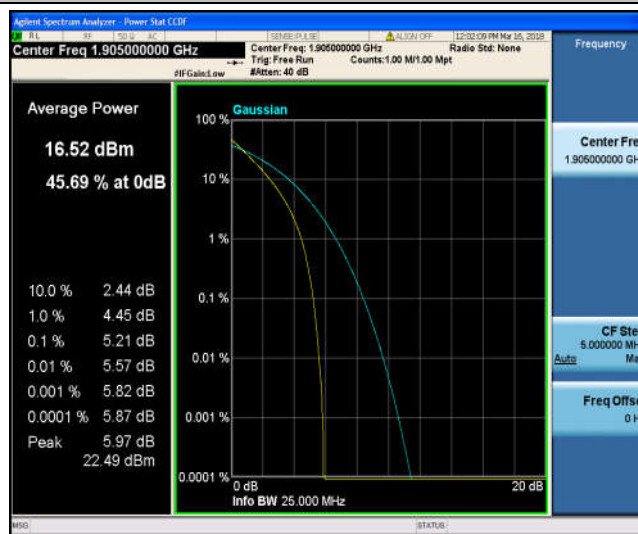

Band2_10MHz_QPSK_19150_50RB#0

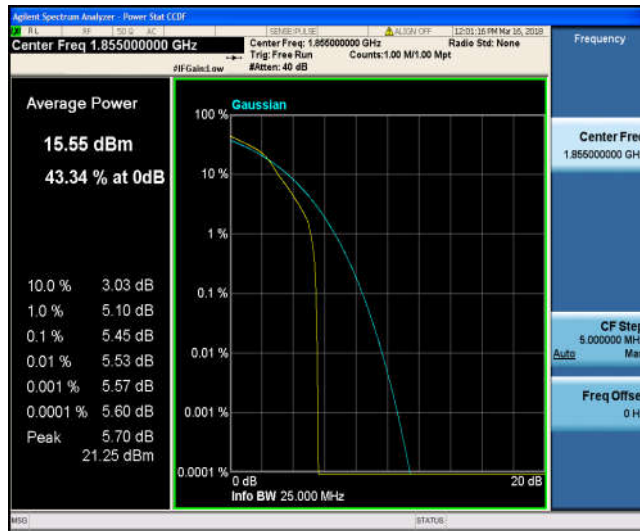

Band2_10MHz_16QAM_18650_1RB#0



Band2_10MHz_16QAM_18650_50RB#0

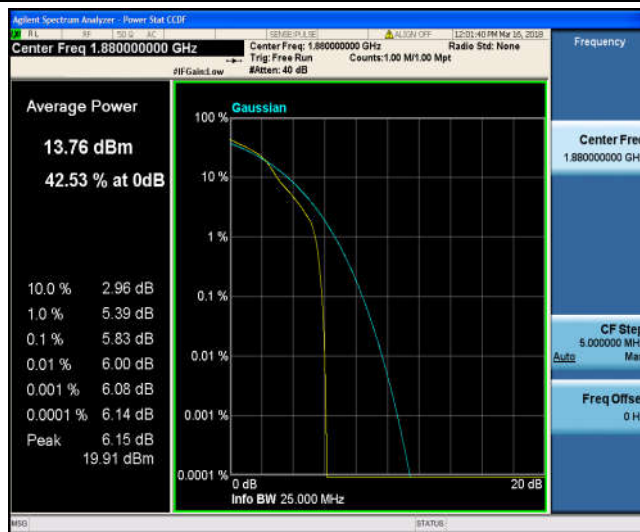

Band2_10MHz_16QAM_18900_1RB#0

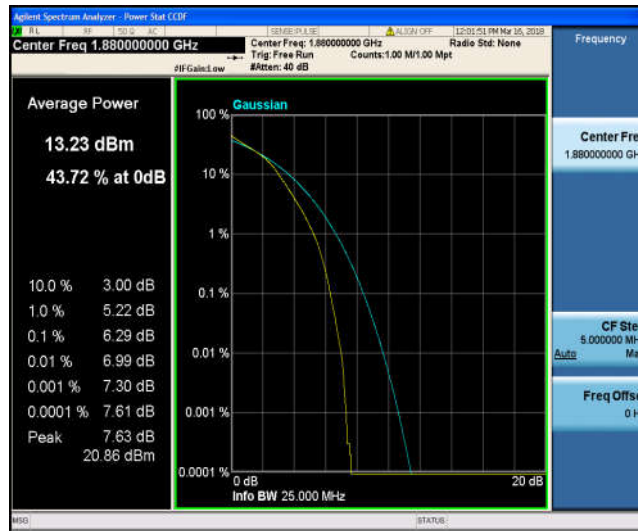

Band2_10MHz_16QAM_18900_50RB#0

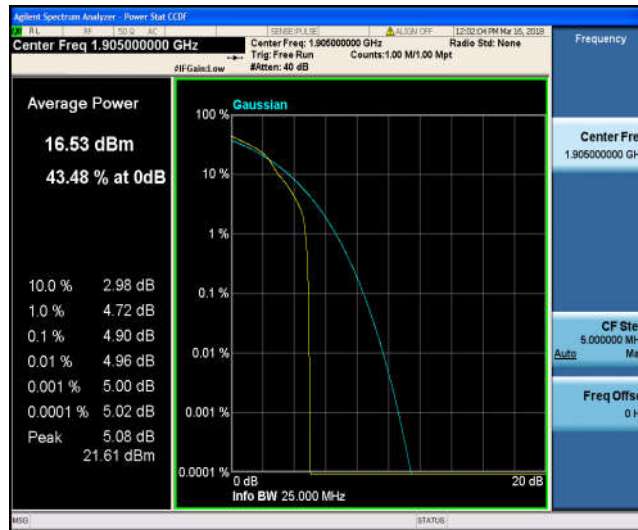

Band2_10MHz_16QAM_19150_1RB#0

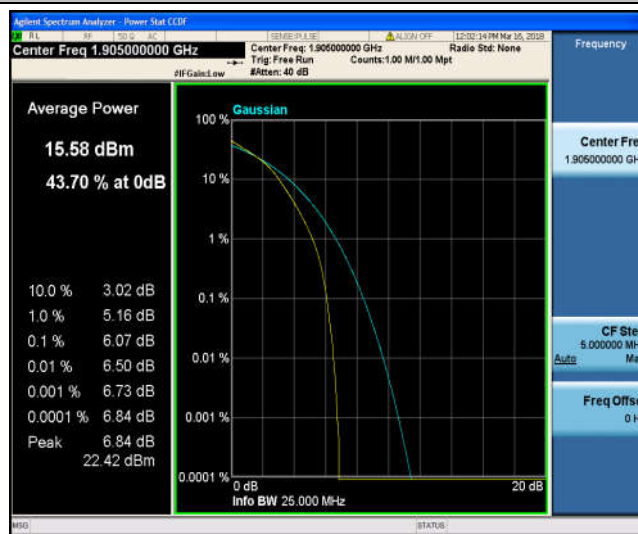

Band2_10MHz_16QAM_19150_50RB#0

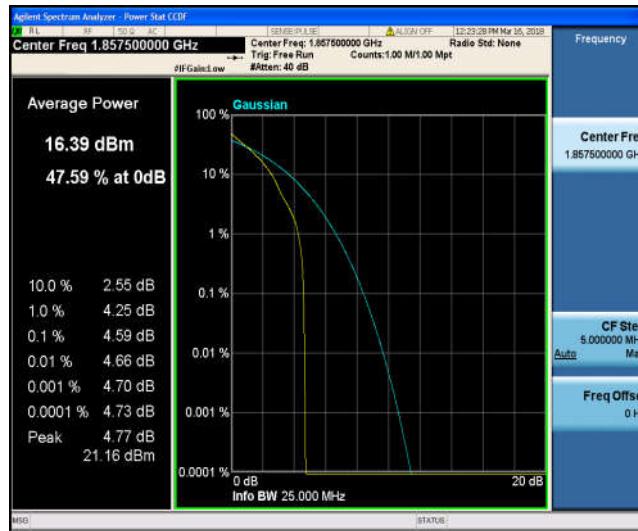

Band2_15MHz_QPSK_18675_1RB#0

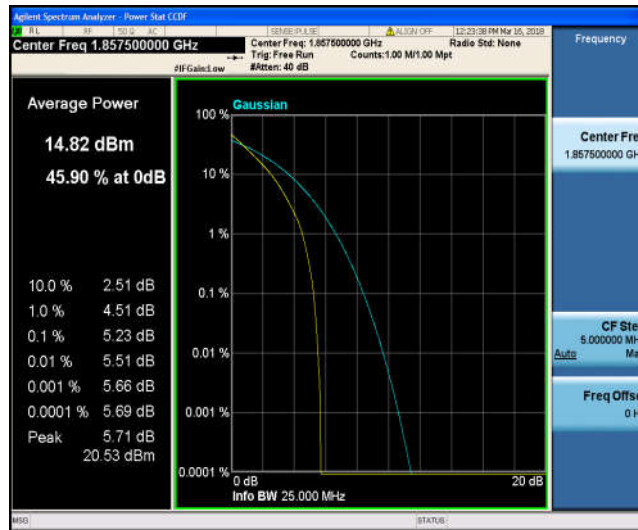

Band2_15MHz_QPSK_18675_75RB#0

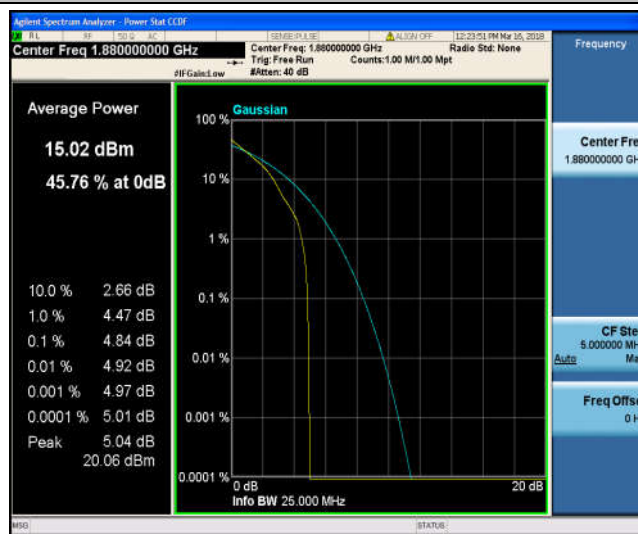

Band2_15MHz_QPSK_18900_1RB#0

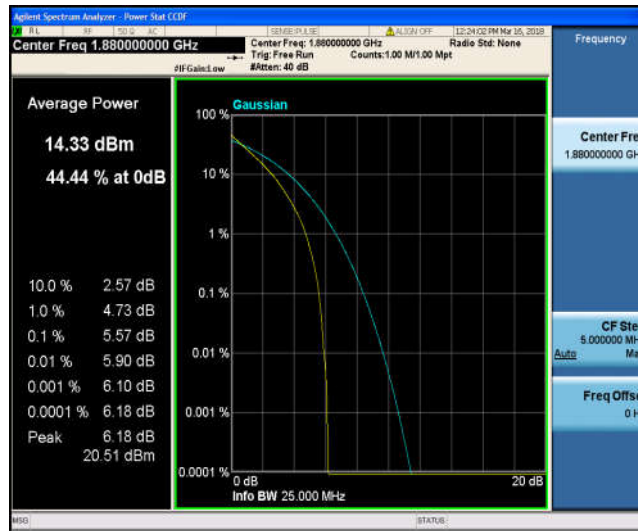

Band2_15MHz_QPSK_18900_75RB#0

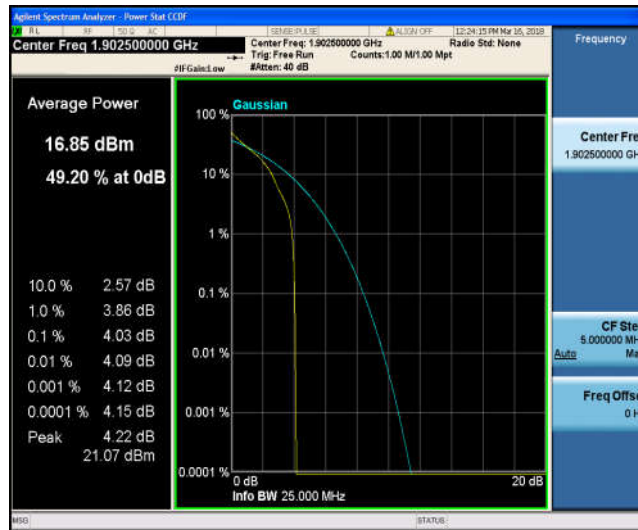

Band2_15MHz_QPSK_19125_1RB#0

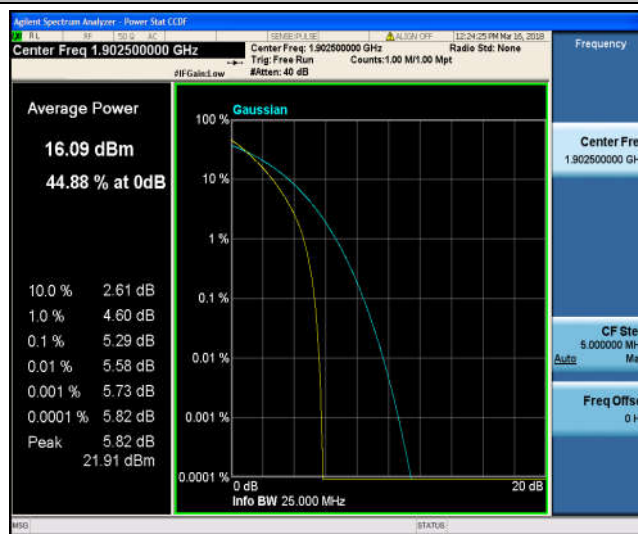

Band2_15MHz_QPSK_19125_75RB#0

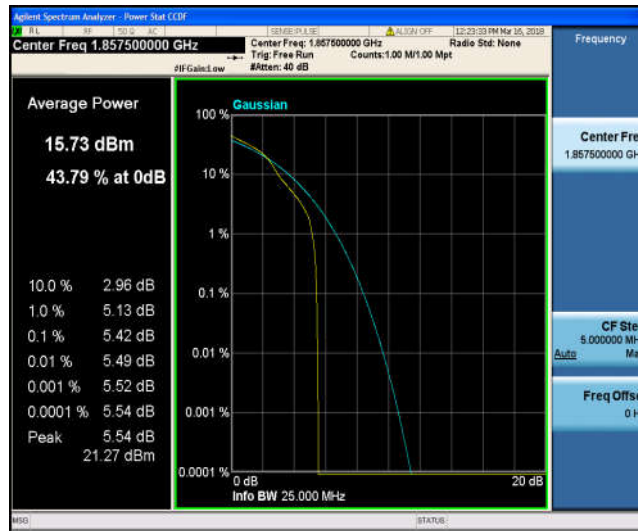

Band2_15MHz_16QAM_18675_1RB#0



Band2_15MHz_16QAM_18675_75RB#0

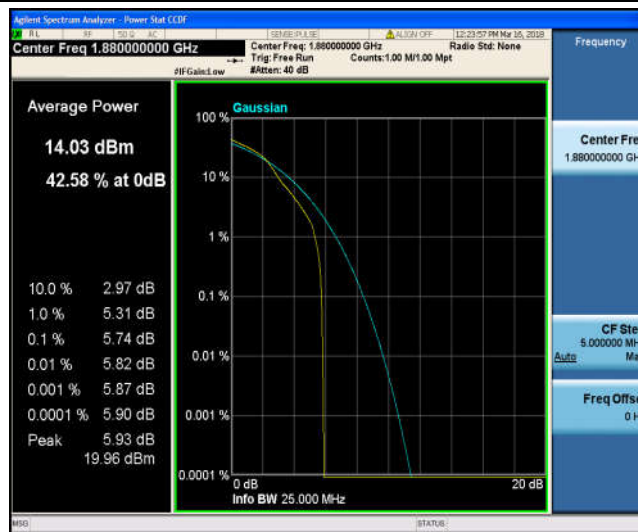

Band2_15MHz_16QAM_18900_1RB#0

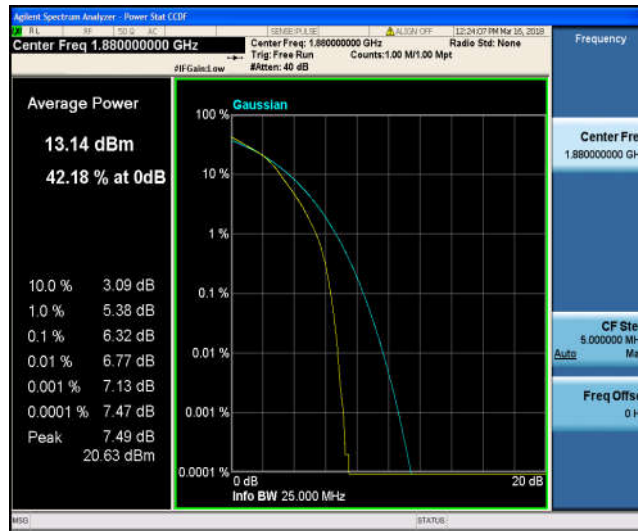

Band2_15MHz_16QAM_18900_75RB#0

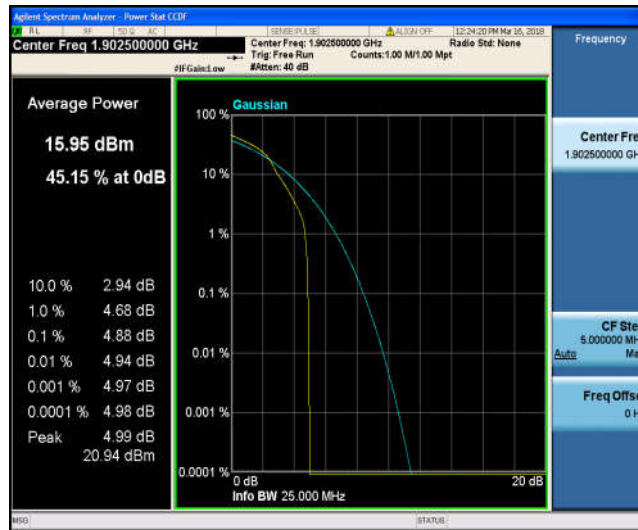

Band2_15MHz_16QAM_19125_1RB#0

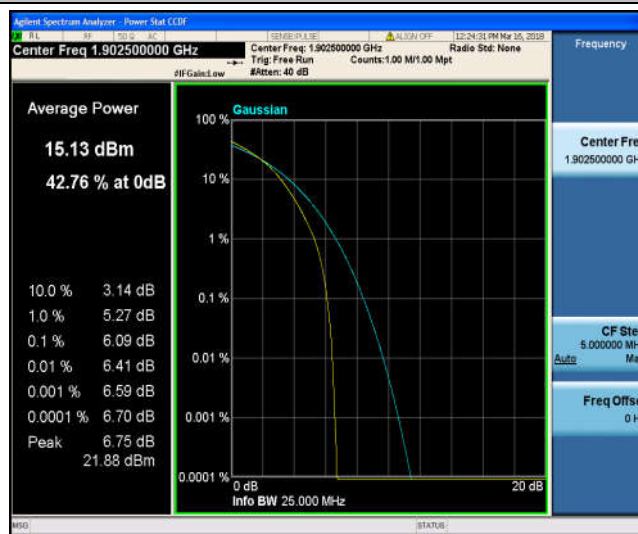

Band2_15MHz_16QAM_19125_75RB#0

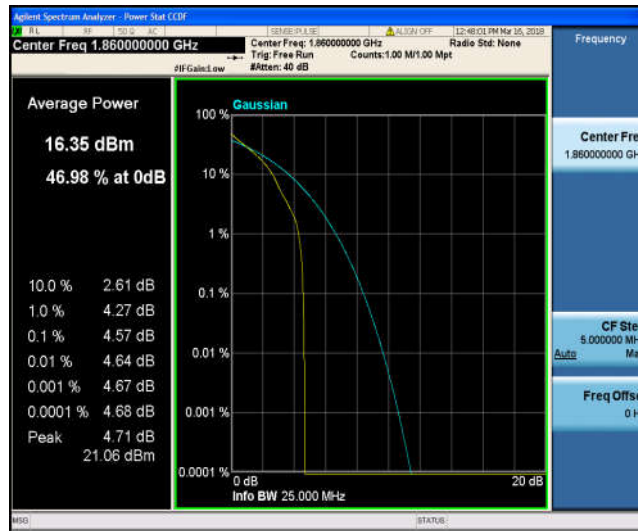

Band2_20MHz_QPSK_18700_1RB#0

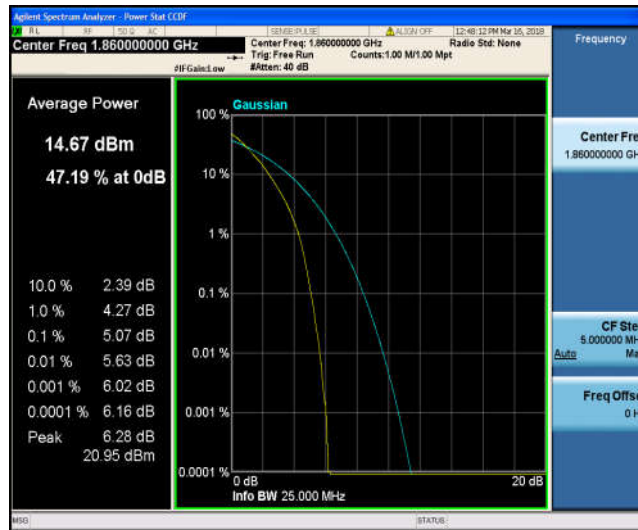

Band2_20MHz_QPSK_18700_100RB#0

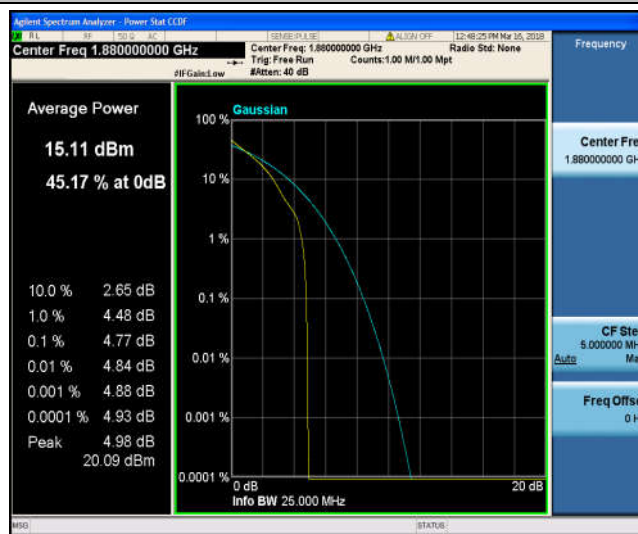

Band2_20MHz_QPSK_18900_1RB#0

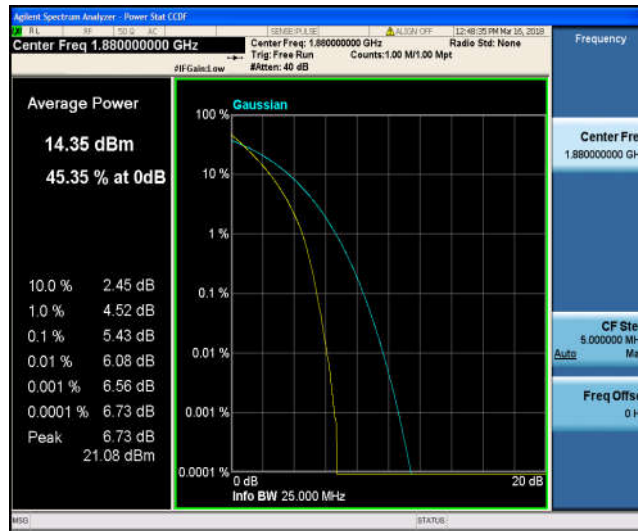

Band2_20MHz_QPSK_18900_100RB#0

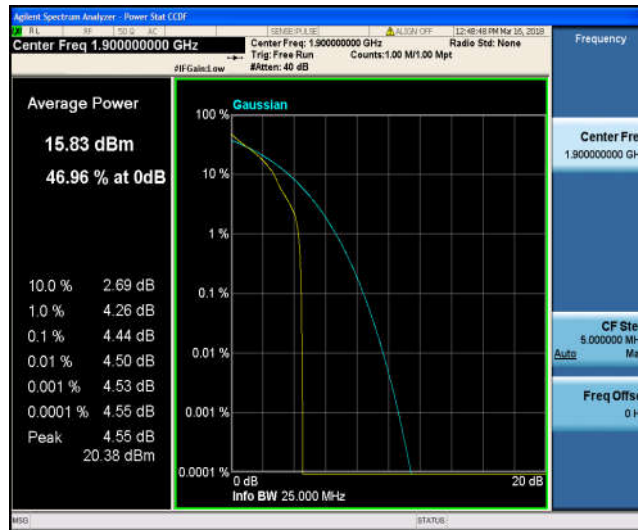

Band2_20MHz_QPSK_19100_1RB#0

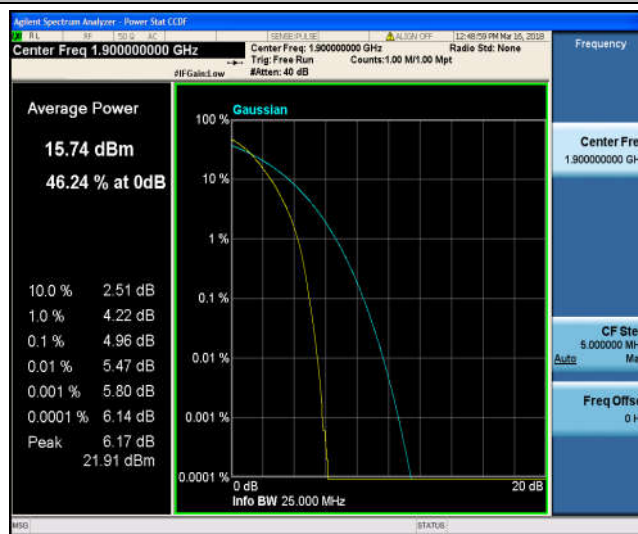

Band2_20MHz_QPSK_19100_100RB#0

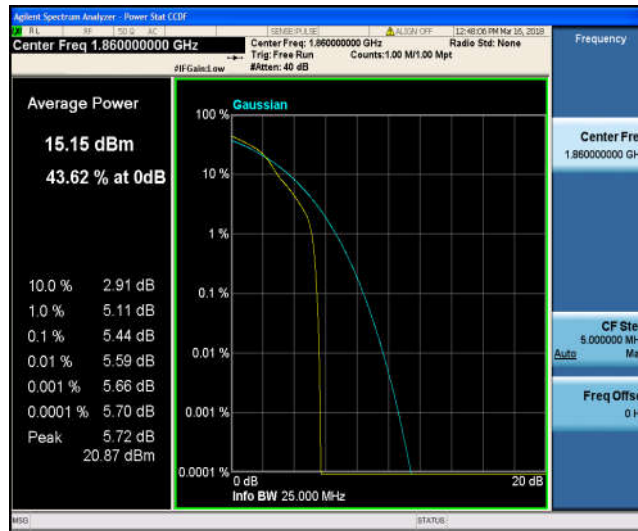

Band2_20MHz_16QAM_18700_1RB#0

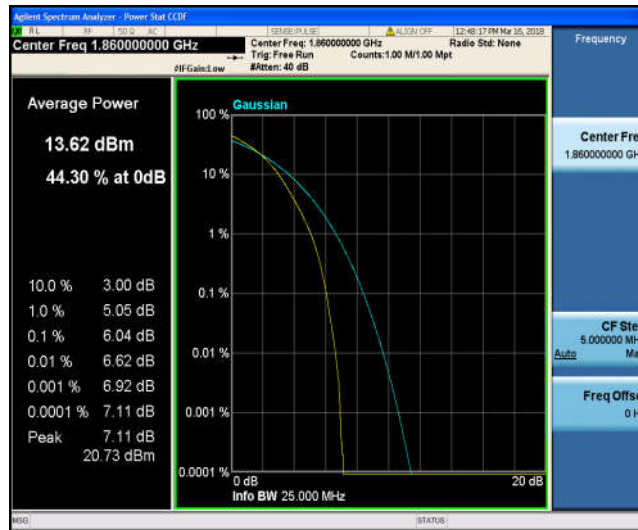

Band2_20MHz_16QAM_18700_100RB#0

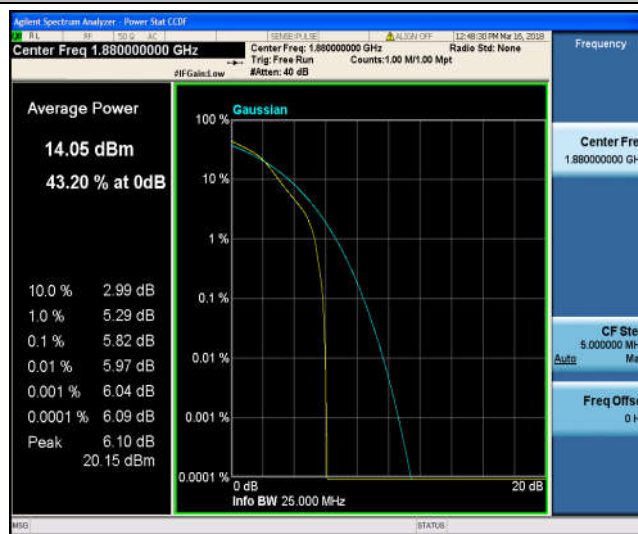

Band2_20MHz_16QAM_18900_1RB#0

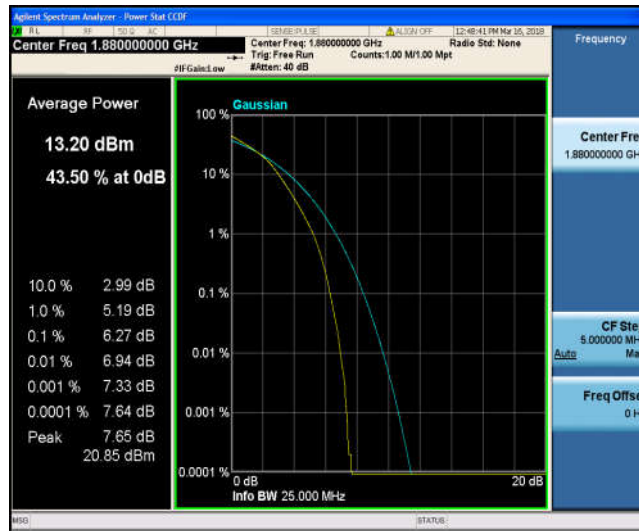

Band2_20MHz_16QAM_18900_100RB#0



Band2_20MHz_16QAM_19100_1RB#0

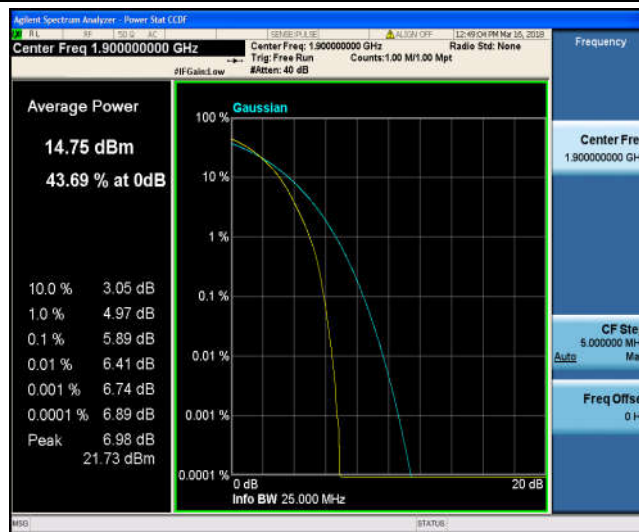

Band2_20MHz_16QAM_19100_100RB#0

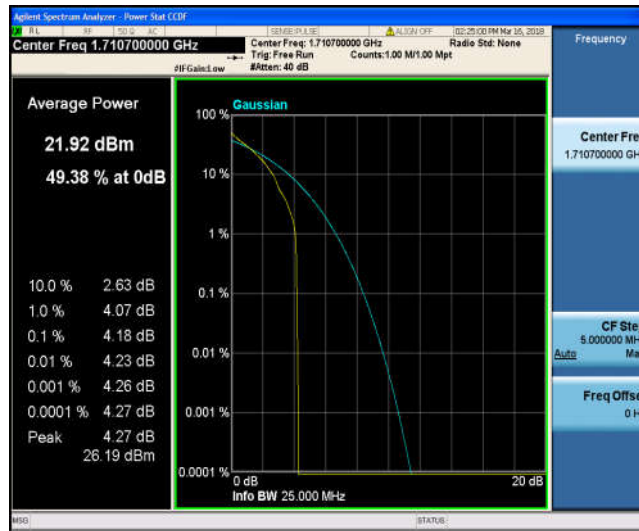

Band4_1.4MHz_QPSK_19957_1RB#0



Band4_1.4MHz_QPSK_19957_6RB#0

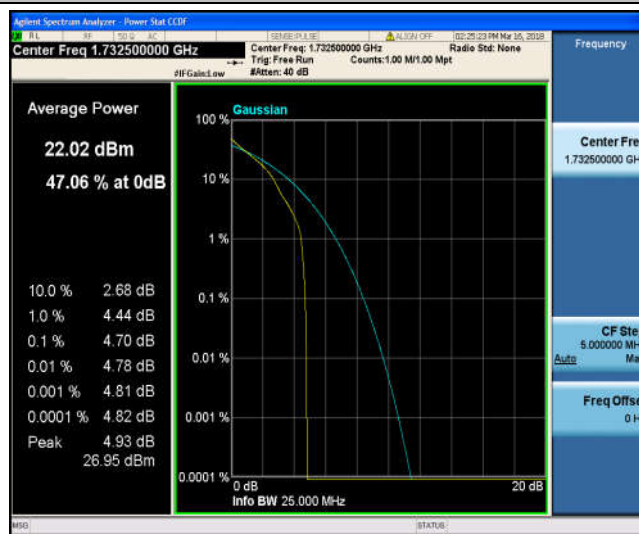

Band4_1.4MHz_QPSK_20175_1RB#0

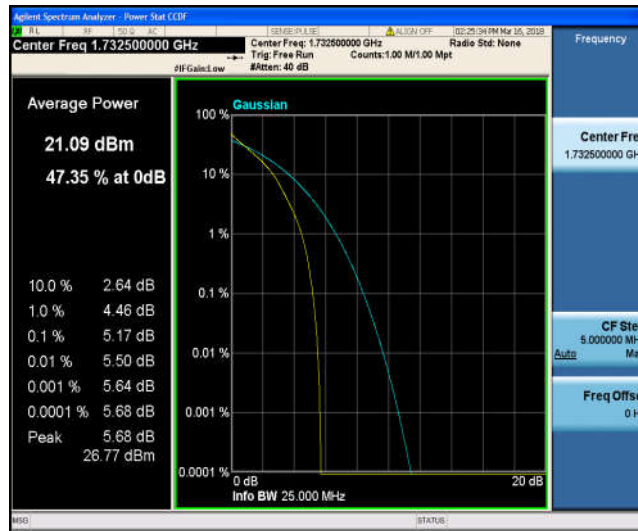

Band4_1.4MHz_QPSK_20175_6RB#0

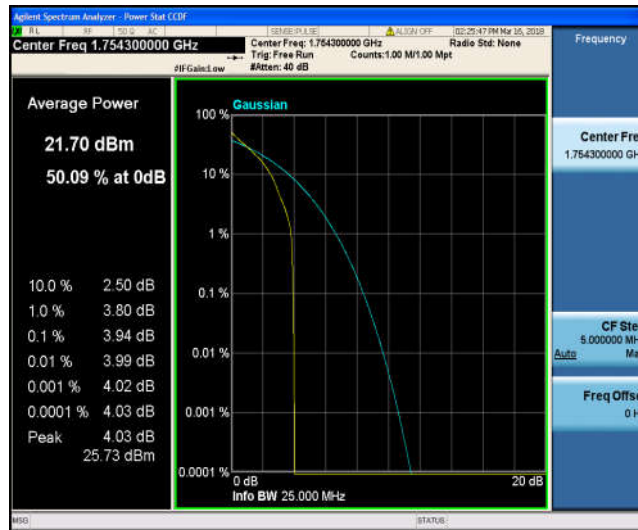

Band4_1.4MHz_QPSK_20393_1RB#0

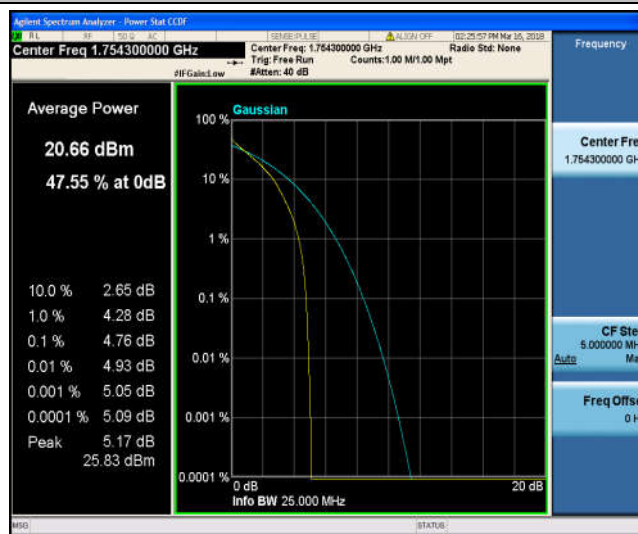

Band4_1.4MHz_QPSK_20393_6RB#0

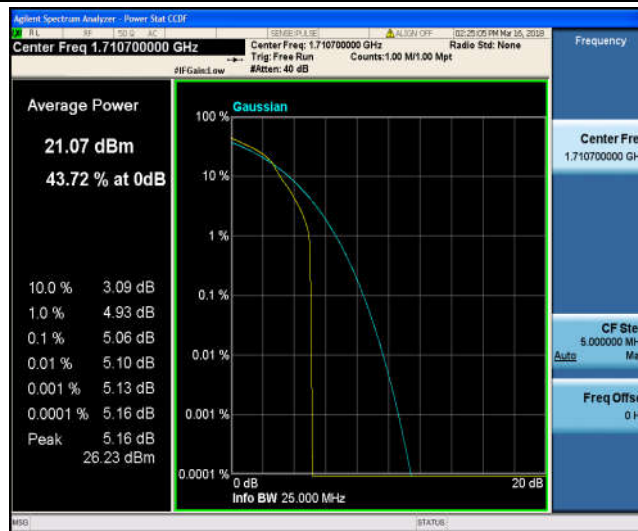

Band4_1.4MHz_16QAM_19957_1RB#0

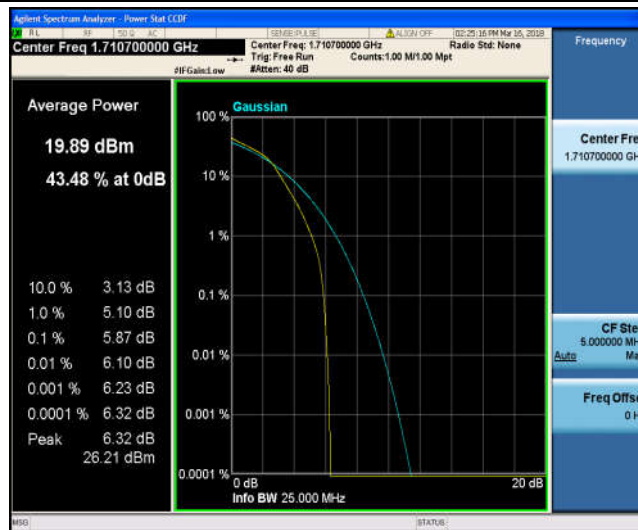

Band4_1.4MHz_16QAM_19957_6RB#0

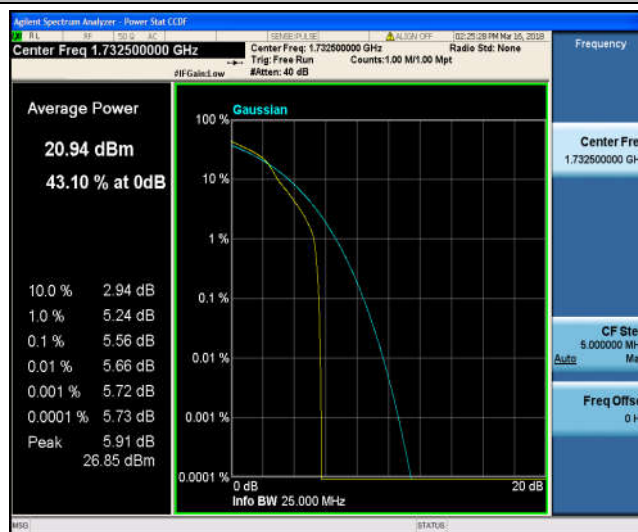

Band4_1.4MHz_16QAM_20175_1RB#0

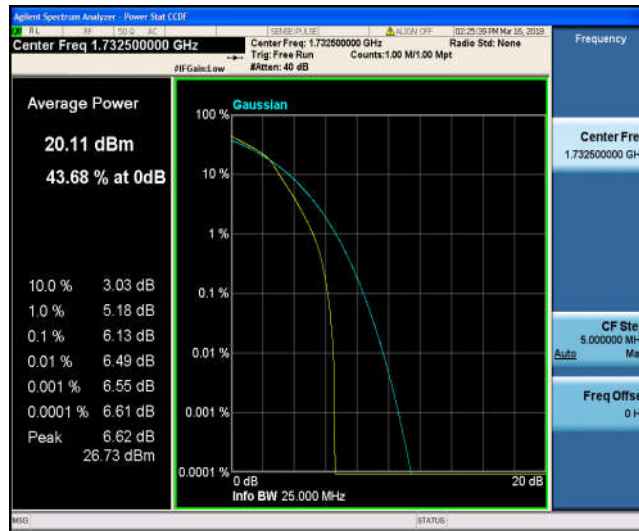

Band4_1.4MHz_16QAM_20175_6RB#0



Band4_1.4MHz_16QAM_20393_1RB#0

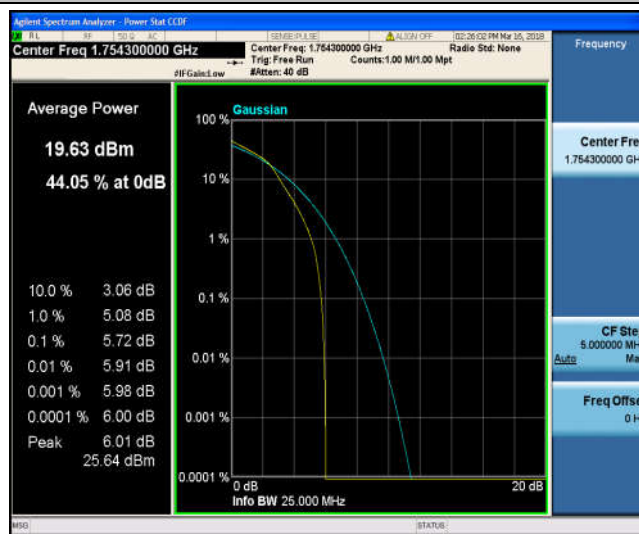

Band4_1.4MHz_16QAM_20393_6RB#0

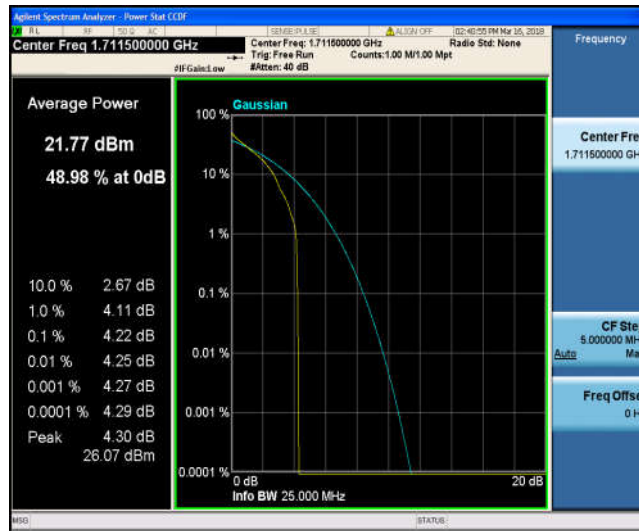

Band4_3MHz_QPSK_19965_1RB#0



Band4_3MHz_QPSK_19965_15RB#0

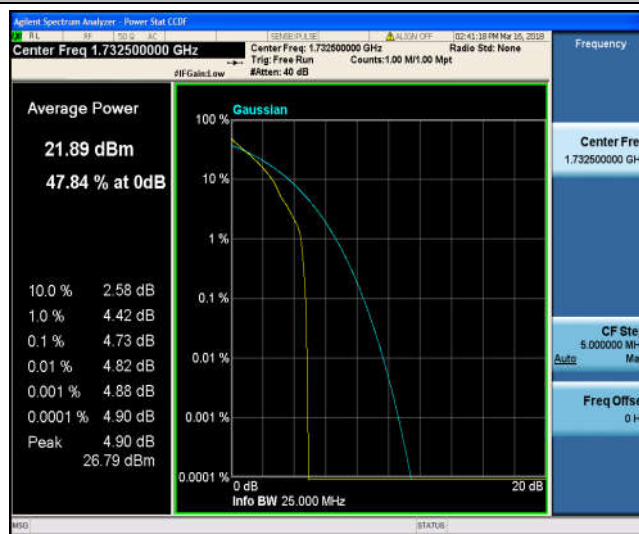

Band4_3MHz_QPSK_20175_1RB#0

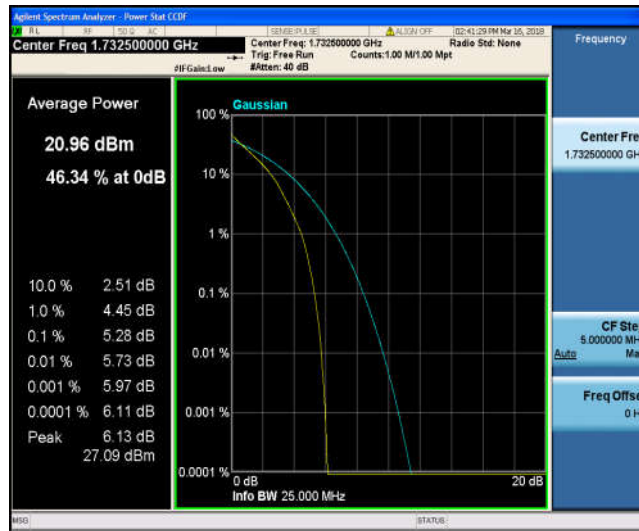

Band4_3MHz_QPSK_20175_15RB#0



Band4_3MHz_QPSK_20385_1RB#0

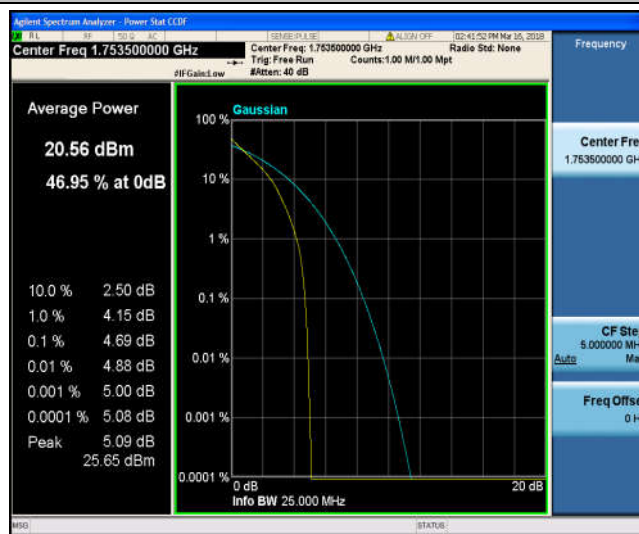

Band4_3MHz_QPSK_20385_15RB#0

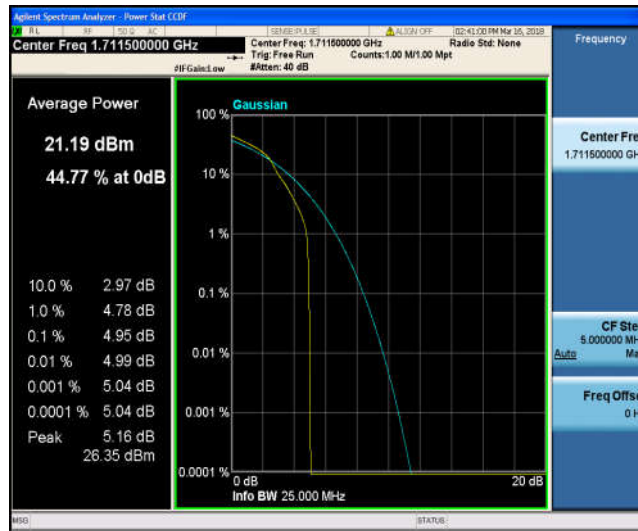

Band4_3MHz_16QAM_19965_1RB#0

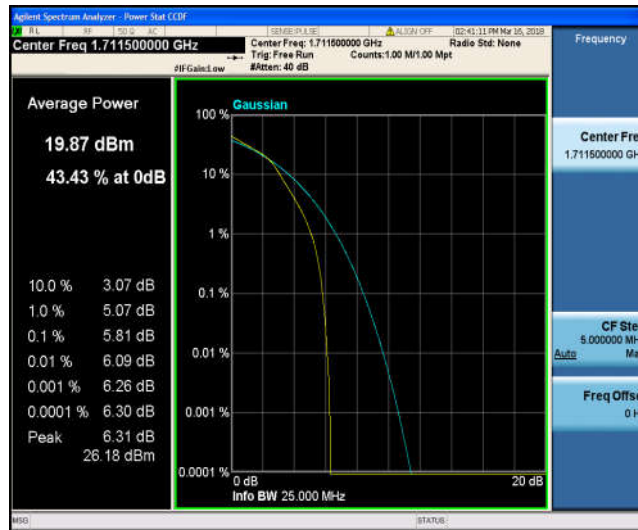

Band4_3MHz_16QAM_19965_15RB#0

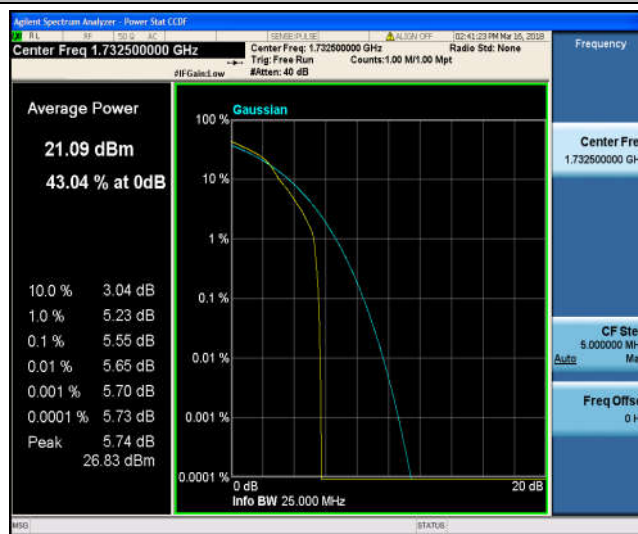

Band4_3MHz_16QAM_20175_1RB#0

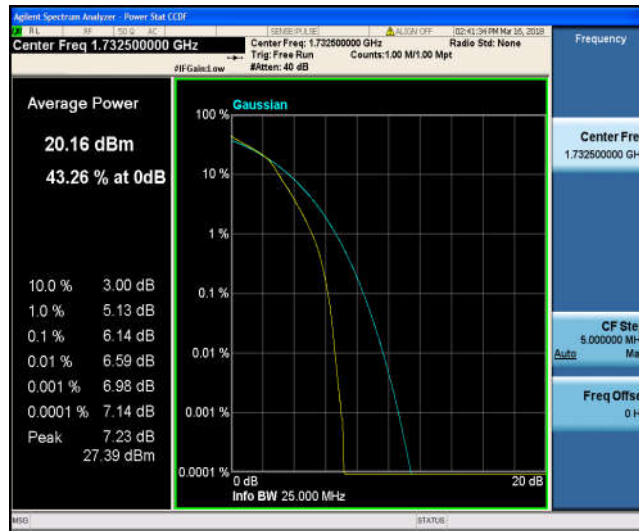

Band4_3MHz_16QAM_20175_15RB#0

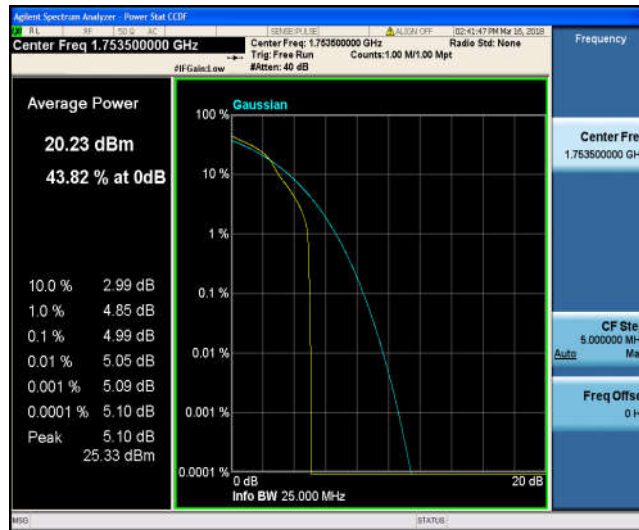

Band4_3MHz_16QAM_20385_1RB#0

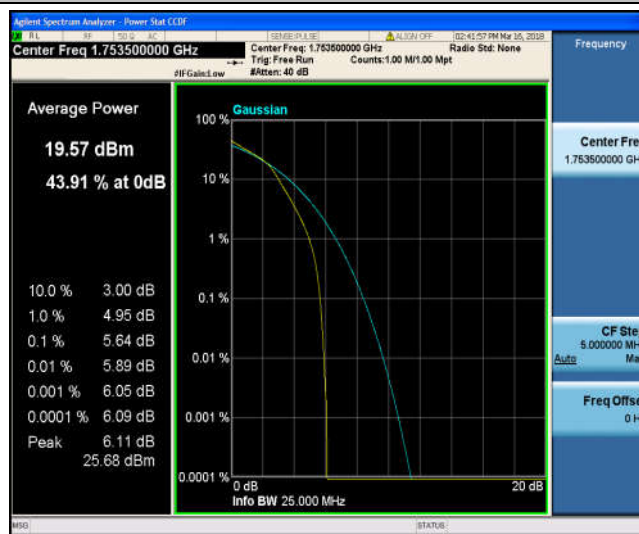

Band4_3MHz_16QAM_20385_15RB#0

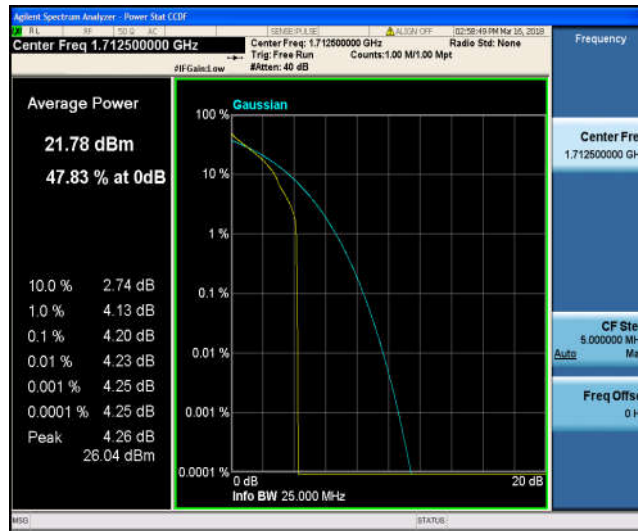

Band4_5MHz_QPSK_19975_1RB#0



Band4_5MHz_QPSK_19975_25RB#0

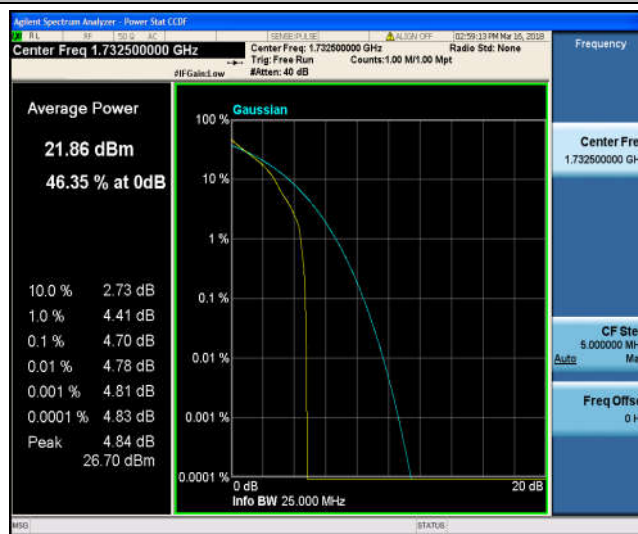

Band4_5MHz_QPSK_20175_1RB#0

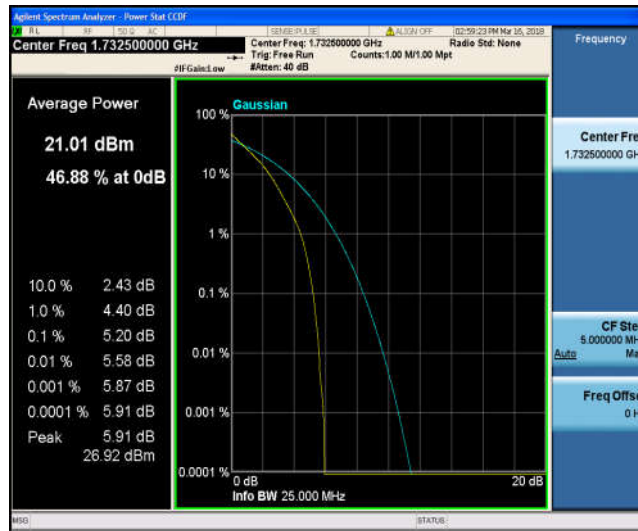

Band4_5MHz_QPSK_20175_25RB#0

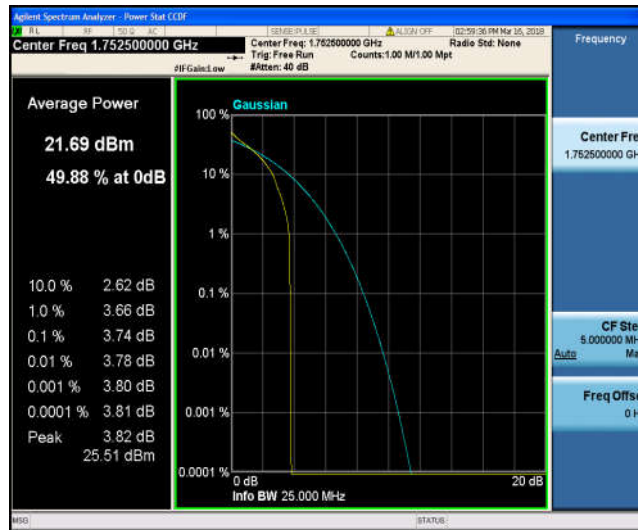

Band4_5MHz_QPSK_20375_1RB#0



Band4_5MHz_QPSK_20375_25RB#0

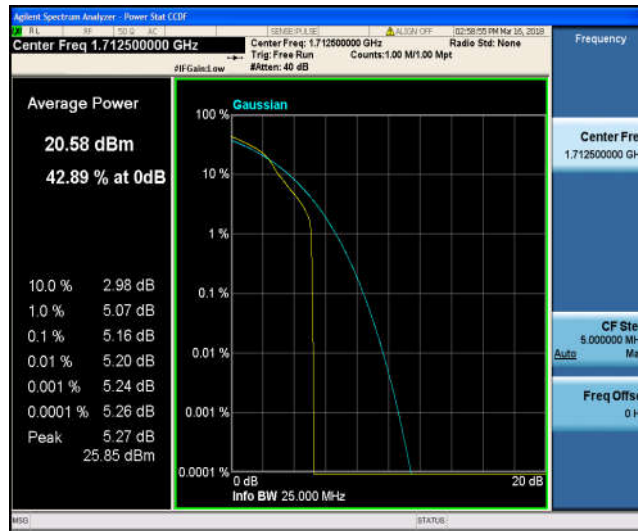

Band4_5MHz_16QAM_19975_1RB#0

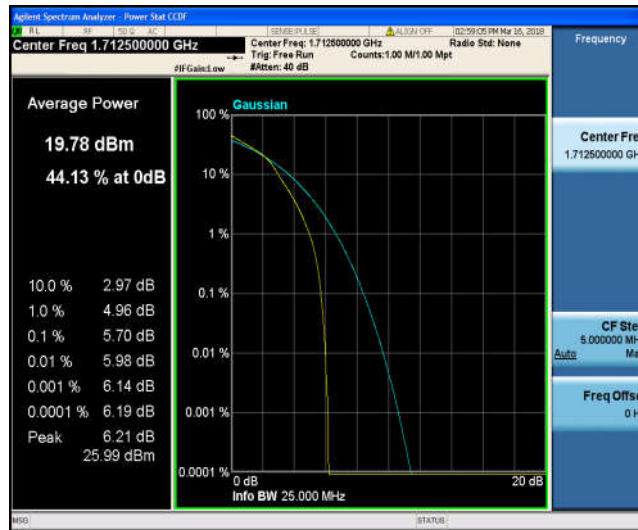

Band4_5MHz_16QAM_19975_25RB#0



Band4_5MHz_16QAM_20175_1RB#0