

PARTIAL TEST REPORT
 No.: 6_0009_11_6_2a

According to:
FCC Regulations
 FCC Part 22H/24E
 FCC Part 15.207C
 FCC Part 15.209C
 &
IC Regulations
 RSS-132, Issue 2
 RSS-133, Issue 5
 RSS-Gen, Issue 3

for

Cinterion Wireless Modules GmbH

Quad-Band GSM/GPRS Module BGS2-W
 (HW B2.2)
 FCC-ID: QIPBGS2
 IC: 7830A-BGS2







Laboratory Accreditation and Listings			
 D-PL-12047-01-01	 Reg. No.: 736496 MRA US-EU 0003	 Industry Canada Reg. No.: 3462D-1 3462D-2	 Reg. No.: R-2665, R-2666 C-2914, T-1967 G-301
 LAB CODE 20011130-00			
accredited according to DIN EN ISO/IEC 17025			
<p align="center"> CETECOM GmbH Laboratory Radio Communications & Electromagnetic Compatibility Im Teelbruch 116 • 45219 Essen • Germany Registered in Essen, Germany, Reg. No.: HRB Essen 8984 Tel.: + 49 (0) 20 54 / 95 19-954 • Fax: + 49 (0) 20 54 / 95 19-964 E-mail: info@cetecom.com • Internet: www.cetecom.com </p>			

Table of contents

1. SUMMARY OF TEST RESULTS	3
1.1. TESTS OVERVIEW FCC Part 15/22/24 and Canada IC Standards (RSS)	3
2. ADMINISTRATIVE DATA	5
2.1. Identification of the testing laboratory	5
2.2. Test location	5
2.3. Organizational items	5
2.4. Applicant’s details	5
2.5. Manufacturer’s details	5
3. EQUIPMENT UNDER TEST (EUT)	6
3.1. Additional declaration and description of main EUT	6
3.2. Configuration of cables used for testing	6
3.3. EUT: Type, S/N etc. and short descriptions used in this test report	7
3.4. Auxiliary Equipment (AE): Type, S/N etc. and short descriptions	7
3.5. EUT set-ups	7
3.6. EUT operating modes	8
3.7. Parameter Settings on mobile phone and base station CMU200	9
4. DESCRIPTION OF TEST SET-UP’S	10
4.1. Test set-up for radiated measurements	10
5. MEASUREMENTS	11
5.1. RF power output (Conducted and Radiated)	11
5.2. Emission limits (Spurious emission conducted/radiated)	13
6. CALIBRATION METHOD OF ANECHOIC CHAMBER	17
7. MEASUREMENT UNCERTAINTIES	18
8. INSTRUMENTS AND ANCILLARY	19
8.1. Used equipment “CTC”	19

Table of annex

	Total pages
SEPARATE DOCUMENT B_6_0009_11_6_2a_A1.PDF: DIAGRAMS OF TESTING	32
SEPARATE DOCUMENT B_6_0009_11_6_2a_A2.PDF: PHOTOS OF EUT	6
SEPARATE DOCUMENT B_6_0009_11_6_2a_A3.PDF: PHOTOS OF SET-UP	4

1. Summary of test results

The presented GSM 850/900/1800/1900 Module can be build inside host applications and extends their capability by wireless GSM technology. Data transmissions or voice applications are possible field applications.

In order to verify the compliance with applicable rules, a representative configuration consisting of representative auxiliary equipment was chosen. Embedded in this configuration, the GSM Module can be tested. Pls. refer to set-up description and photos for more details.

Due to some PCB modifications (pls. consult applicants technical documents) radiated spurious emission and radiated power (erp&eirp) tests have been performed again, for a permissive change class 2.

Regarding spurious emissions the most critical channel of the two operational bands has been re-tested and in addition also the band-edge compliance. The radiated power has been re-tested for all three channels: low, middle and high of both operational bands.

Following tests have been performed to show compliance with applicable FCC Part 2, Part 22, Subpart H and Part 24, Subpart E (Broadband PCS) of the FCC CFR 47 Rules and RSS-132, RSS-133 and RSS-Gen.

The test results apply exclusively to the test samples as presented in chapter 3.1. The CETECOM GmbH does not assume responsibility for any conclusions and generalizations taken in conjunction with other specimens or samples of the type of the item presented to tests.

1.1. TESTS OVERVIEW FCC Part 15/22/24 and Canada IC Standards (RSS)

TEST CASES	PORT	REFERENCES & LIMITS			EUT set-up	EUT operating mode	Result
		FCC Standard	RSS Section	TEST LIMIT			
TX-Mode							
RF POWER (conducted)	Antenna terminal (conducted)	§2.1046	--	N/A	--	--	Not tested 1.)
RF-POWER radiated (ERP/EIRP)	Cabinet	§2.1046 §22.913(a)(2) §24.232(c)	RSS-132: 4.4 SRSP-503: 5.1.3 RSS-133:4.1/6.4 SRSP-510: 5.1.2	FCC: < 7 Watt (ERP) IC: < 6.3 Watt (ERP) < 2 Watt (EIRP)	1	1+2	Passed
SPURIOUS EMISSIONS (conducted)	Antenna terminal (conducted)	§2.1051 §22.917(a)(b) §24.238(a)(b)	RSS-132: 4.5.1.1 RSS-133: 6.5.1(a)(i)	43+10log(P) dBc	--	--	Not tested 1.)
99% OCCUPIED BANDWIDTH	Antenna terminal (conducted)	§2.202 §2.1049	RSS-Gen:4.6.1	99% Power	--	--	Not tested 1.)
SPURIOUS EMISSIONS (radiated)	Cabinet+ Interconnecting cables (radiated)	§15.209(a)	RSS-Gen: 4.11+ 7.2.5., Table 6	2400/F(kHz) µV/m 24000/F(kHz) µV/m 30 µV/m	--	--	Not tested 1.)
		§2.1053(a) §2.1057(a)(1) §22.917(a)(b) §24.238(a)(b)	RSS-132: 4.5.1.1 RSS-133: 6.5.1(a)(i) 6.5.1(b)	43+10log(P) dBc	1	1+2	Passed

FREQUENCY STABILITY	Antenna terminal (conducted)	§22.355, table C-1 §24.235 §2.1055(a)(1)	RSS-132: 4.3 RSS-133: 6.3 RSS-Gen, Issue 3: Chapter 4.7	< 2.5ppm <0.1 ppm	--	--	Not tested 1.)
AC-Power lines Conducted emissions	AC-mains	§15.207	RSS-Gen, Issue 3, Chapter 7.2.4	FCC §15.207, limits IC: Table 4, Chapter 7.2.4	--	--	Not tested 1.)

Remark: 1.) see initial test report 2_20795542b/11 and corresponding annexes

RX Mode							
AC-Power Lines Conducted Emissions	AC-Power lines	§15.107	RSS-Gen, Issue 3: Chapter 7.2.4	FCC §15.107 class B limits §15.207 limits IC: Table 4, Chapter 7.2.4	Remark 1	Remark 1	Not tested Remark 1
RECEIVER Radiated emissions	Cabinet + Interconnecting cables (radiated)	§15.109 §15.33 §15.35	RSS-132, Issue 2: Chapter 4.6 RSS-Gen, Issue 3: Chapter 6.1 RSS-133, Issue 5: 6.6	FCC 15.109 class B limits IC-limits: Table 2, Chapter 6.1	Remark 1	Remark 1	Not tested Remark 1
RECEIVER Conducted emissions	Antenna terminal (conducted)	§2.1051 §15.111(a)	RSS-Gen, Issue 3: Chapter 6.2 RSS-132, Issue 2: Chapter 4.6 RSS-133, Issue 5: Chapter 6.6	43+10log(P) dBc IC: < 2 nW/4kHz (30<F<1000MHz) < 5nW/4kHz (F> 1GHz)	Remark 1	Remark 1	Not tested Remark 1

Remark:

1.) See initial separate test report 2_20795542c/11 and corresponding annexes A1/A2 for measurements according Part 15, Subpart B.

ATTESTATION:

I declare that all measurements were performed by me or under my supervision and that all measurements have been performed and are correct to my best knowledge and belief to Industry Canada standards. All requirements as shown in above table are met in accordance with enumerated standards.

.....
Dipl.-Ing. W. Richter
Responsible for testsection

GmbH
Im Teelbruch 116
45219 Essen
Tel.: + 49 (0) 20 54 / 95 19 - 0
Fax: + 49 (0) 20 54 / 95 19 - 997

.....
Dipl.-Ing. C. Lorenz
Responsible for test report

2. Administrative Data

2.1. Identification of the testing laboratory

Company name:	CETECOM GmbH
Address:	Im Teelbruch 116 45219 Essen - Kettwig Germany
Laboratory accreditations/Listings:	DAkkS-Registration No. D-PL-12047-01-01 FCC-Registration No.: 736496, MRA US-EU 0003 IC-Registration No. 3462D-1, 3462D-2 VCCI Registration No. R-2665,R-2666,C-2914,T-339
Responsible for testing laboratory:	Dipl.-Ing. W. Richter
Deputies:	Dipl.-Ing. J.Schmitt

2.2. Test location

2.2.1. Test laboratory "CTC"

Company name:	see chapter 2.1. Identification of the testing laboratory
---------------	---

2.3. Organizational items

Order No.:	6_0009_11_6_2
Responsible for test report and project leader:	Dipl.-Ing. C. Lorenz
Receipt of EUT:	2011-05-06
Date(s) of test:	2011-05-06
Date of report:	2011-05-11

Version of template:	09.06 _All.Dotm

2.4. Applicant's details

Applicant's name:	Cinterion Wireless Modules GmbH
Address:	Siemensdamm 50 13629 Berlin Germany
Contact person:	Mr. Stefan Ludwig

2.5. Manufacturer's details

Manufacturer's name:	please see Applicant's details
Address:	please see Applicant's details

3. Equipment under test (EUT)

3.1. Additional declaration and description of main EUT

Main function	GSM/GPRS Quad-Band Module		
Type	BGS2-W		
GSM Frequency range (USA/Canada bands)	GSM 850: 824 – 849MHz (Uplink), 869-894MHz (Downlink) GSM1900: 1850-1910MHz (Uplink), 1930-1990MHz (Downlink)		
Type of modulation	GMSK		
Number of channels (USA/Canada bands)	GSM 850: 128 – 251, 125 channels GSM1900: 512 – 810, 300 channels		
EMISSION DESIGNATOR(S)	245KGXW		
Antenna Type: External magnet mount antenna for vehicular use	<input type="checkbox"/> Integrated <input type="checkbox"/> External, no RF- connector <input checked="" type="checkbox"/> External, separate RF-connector	Frequency range: GSM 850: 824 – 894 MHz GSM 1900: 1850-1990 MHz	
Antenna Gain	<input checked="" type="checkbox"/> radiated: Max. 2 dBi gain at GSM1900		
MAX PEAK Output Power: Radiated ERP Radiated EIRP	GSM850 GSM1900	27.83 dBm (Burst PK) 27.61 dBm (Burst PK)	
MAX PEAK Output Power: Conducted Conducted	GSM 850 GSM1900	32.40 dBm (PK), see initial tests on Hardware B2.1 29.89 dBm (PK), see initial tests on Hardware B2.1	
FCC-ID	QIPBGS2		
IC	7830A-BGS2		
Installed option	<input checked="" type="checkbox"/> GSM900 and GSM1800 Bands		
Special EMI components	--		
Power supply	Internally supplied and controller by the DSB75 Board for tests: $V_{MIN}=3.3V$ to $V_{MAX}=4.5V$ DSB75 Box was DC supplied with 9V external power supply		
EUT sample type	<input type="checkbox"/> Production	<input checked="" type="checkbox"/> Pre-Production	<input type="checkbox"/> Engineering

3.2. Configuration of cables used for testing

Cable number	Item	Type	S/N serial number	HW hardware status	Cable length
Cable 1	RS232	unshielded	CTC	--	1.8m
Cable 2	USB cable	shielded	CTC	--	1.5m

3.3. EUT: Type, S/N etc. and short descriptions used in this test report

Short description*)	EUT	Type	S/N serial number	HW hardware status	SW software status
EUT A	Quad-Band GSM/GPRS Module	BGS2-W	IMEI: 356496040024 333	B2.2	01.301
EUT B	Magnetic Mount antenna	MAR-C3G-2F	CTC#1	2dBi Gain	--
EUT C	Handset Votronic	For M20T, MC35T, TC35T, DSB35	401795321130 4	HH-SI- 30.3/V2.0/0	--
EUT D	Adapter Board for BGS2-W	Ven_60/80_0035	#1	--	--
EUT E	DSB Board + flat ribbon connection+ Adapter BG2_PH8_Ada_0207	DSB75	0911007 ICM-100012- 03	B1.1	--

*) EUT short description is used to simplify the identification of the EUT in this test report.

3.4. Auxiliary Equipment (AE): Type, S/N etc. and short descriptions

AE short description *)	Auxiliary Equipment	Type	S/N serial number	HW hardware status	SW software status
AE 1	Notebook	Dell D610D	CTC PC3	--	Windows XP + Terminal program

*) AE short description is used to simplify the identification of the auxiliary equipment in this test report.

3.5. EUT set-ups

EUT set-up no. *)	Combination of EUT and AE	Remarks
Set. 1	EUT A + EUT B+ EUT C + EUT D + EUT E + AE1	set-up used for tests: radiated AE1 connected during tests but switched-off

*) EUT set-up no. is used to simplify the identification of the EUT set-up in this test report.

3.6. EUT operating modes

EUT operating mode no. *)	Description of operating modes	Additional information
op. 1	GSM 850 TCH mode TCH=128/192/251	A communication link is established between the mobile station and the test simulator. The transmitter is operated at its maximum rated output power: 33 dBm (power class 4; power control level 5). The input signal to the receiver is modulated with normal test modulation. The wanted RF input signal level to the receiver of the mobile station is set to a level to provide a stable communication link.
op. 2	GSM 1900 TCH mode TCH=512/661/810	A communication link is established between the mobile station and the test simulator. The transmitter is operated at its maximum rated output power: 30 dBm (power class 1; power control level 0). The input signal to the receiver is modulated with normal test modulation. The wanted RF input signal level to the receiver of the mobile station is set to a level to provide a stable communication link

*) EUT operating mode no. is used to simplify the test report.

3.7. Parameter Settings on mobile phone and base station CMU200

Following settings apply to the MS during the measurements in GSM/(E)GPRS-Mode only:

Parameter	Traffic Mode	Idle Mode
Traffic Channels mobile station (EUT)	GSM 850 TCH _{MS} = 128/ 192 /251 GSM 1900 TCH _{MS} = 512 / 681 / 810	--
maximum power level (PCL)	GSM 850: PCL = 5 (2 Watt) GSM 1900: PCL = 0 (1 Watt)	--
Modulation	GSM: GMSK-Modulation Scheme EDGE: 8-PSK Modulation Scheme	--
DTX	off	--
Bitstream	PRBS 2E9-1 (pseudo-random-sequence) – CCITT 0.153	
Timeslot	3	
Hopping	off	
Timeslot (slot mode)	GSM-Mode: single GPRS-Mode: maximum allowed uplink slots no. according MS class	
MS slot class	Class 10	
Maximum data transmission rate, single time slot	GSM: 17,6 kBit/s Slot EDGE: 59,2 kBit/s Slot	
Speech transcoding (Traffic Mode)	Full rate Version 1	
Mode	BCCH and TCH	
BCCH – base station (CMU,CMD)		GSM 850: 182 GSM 1900: 651
TCH – base station (CMD, CMU)	auto	
Power level TCH – base station (used timeslot level)	- 70 dBm	
Power level BCCH – base station (control channel level)	- 80 dBm	
External attenuation RF/AF-Input/Output	Accord. calibration prior to measurements	
Mobile Country Code	310	310
BS_AG_BLK_RES		0
Paging reorganisation		Off (0)
Signalling channel	Not applicable	SDCCH
Location Update		Auto
Cell access		Disabled (barred)

Settings for CMU (general)

Repetition	Continuous
Stop condition	None
Display mode	Max./Min
Statistic Count	1000 Bursts
Decoder	Standard

Additional settings on the base stations CMU200 for frequency stability measurements

4. DESCRIPTION OF TEST SET-UP's

4.1. Test set-up for radiated measurements

The radiated emissions from the test device are measured first as exploratory measurement in a FCC recognized semi anechoic chamber or fully anechoic chamber with the dimensions of 8.05m x 6.85m x 5.48m. Very critical frequencies within a defined range, can be re-checked on CETECOM's Open Area Test side, recognized by the FCC to be compliant with ANSI 63.4: 2003.

The EUT and accessories are placed on a non-conducting tipping table of 0.8 meter height (semi-anechoic chamber) or 1.55m height (fully-anechoic chamber) which is situated in the middle of the turntable. The turntable can rotate the device under test 360 degree, the tipping table can rotate the device from laid to standing position. This way the device under test can be rotated in all three orthogonal planes in order to maximize the detected emissions. The turn- and tipping table are controlled by a controller unit. All positions manipulations are software controlled from a operator PC.

The measurements are performed for both receiving antenna polarisations: vertical and horizontal.

Up to 18GHz a measurement distance of 3 meters is used, above 18GHz the distance is 1 meter. A biconical-logarithmic antenna up to 1 GHz and a horn antenna for frequencies above 1 GHz used. (see equipment list)

The EUT is powered either by a external DC-supply with nominal voltage or a AC/DC power supply as accessory. The communication signalling is performed from outside the chamber with a communication test simulator (CMU200 from Rohde&Schwarz) by airlink.

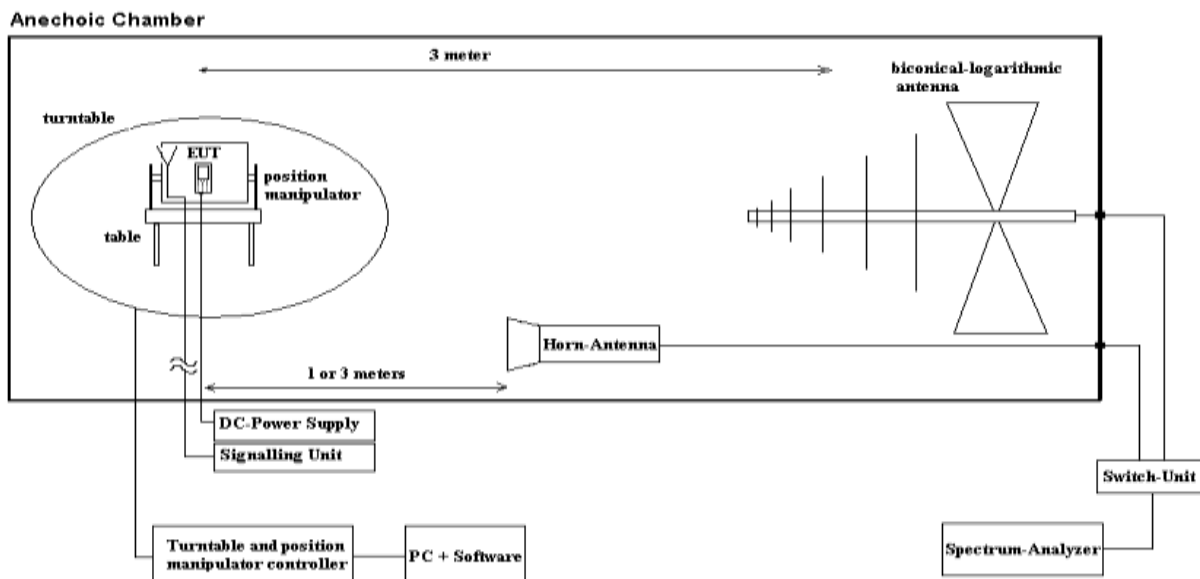

Schematic: radiated measurements test set-up

5. Measurements

5.1. RF power output (Conducted and Radiated)

REFERENCES

FCC: §2.1046 (conducted), §22.913(a)(2), § 24.232(c)

IC: RSS-132:4.4 + SRSP 503:5.1.3 for GSM 850; RSS-133:4.1/6.4 + SRSP-510:5.1.2 for GSM 1900

MOBILE PHONE SETTINGS

- according 3.7

BASE STATION SETTING

- according 3.7

5.1.1. Radiated RF-Power

TEST METHOD

The measurements were made at the upper, center, and lower carrier traffic frequencies of each of the supported operating band. Choosing three TX-carrier frequencies of the mobile phone, should be sufficient to demonstrate compliance.

The measurements were performed by using the **substitution method** (ANSI/TIA/EIA 603) with a spectrum-analyzer. This method can be described like follows:

- 1.) choosing of suitable spectrum-analyzer settings for performing the measurements. This settings of the spectrum analyzer must be maintained for both stages of the measurements: EUT emission measurements and also for measurements of the substituted level.

Parameter	Setting for GSM measurements	Settings for UTRA/FDD measurements
RBW	3 MHz	10 MHz
VBW	10 MHz	10 MHz
Span	8 MHz	8 MHz
Detector Mode	Positive max-hold	Positive max-hold
Average	off	off
Sweep Time	coupled	coupled

- 2.) The maximum level of the peak power was recorded, while the emissions were maximized by rotating the EUT in three orthogonal axes, which was situated on a non-conductive turntable of 1.55 m height ($P_{MEAS,1}$). This was performed for both measuring antenna polarisations (vertical/horizontal), the maximum of both values is used for further measurements and final substitution ($P_{MEAS,1,MAX}$).
- 3.) As the maximum emission is recorded, the EUT is replaced by a frequency dependant suitable antenna, which is connected to a RF-signal generator, which is transmitting on the determined worst-case frequency as determined in step 2.
- 4.) The RF-signal level of the signal generator is adjusted as long the same worst-case level determined first step is measured at the spectrum analyzer ($P_{SMHU}=P_{MEAS,1,MAX}$)
- 5.) Than the RF-signal cable is disconnected from the antenna and connected to a power-level meter. The level is determined ($P_{MEAS,2}$).
- 6.) The final result is calculated by adding the ERP/EIRP gain of the antenna which substitutes the EUT.

$$P_{EUT,SUBST} = P_{MEAS,2} + G_{Antenna}$$

GSM RESULTS (RADIATED):

OP. MODE 1, SET-UP 1

Channel/ Frequency (MHz)		Peak Output Power (dBm)		Antenna Polarisation for maximum Power	Verdict	
		PK	AV			
GSM 850	Channel 128/ 824.2 MHz	25.47	1.)	ERP-Value	V/H	Passed
	Channel 192/ 837.0 MHz	27.83				
	Channel 251/ 848.8 MHz	23.41				
E-GPRS 850	Channel 128/ 824.2 MHz	Not supported mode	1.)	ERP-Value	V/H	--
	Channel 192/ 837.0 MHz					
	Channel 251/ 848.8 MHz					

Remark: -

1.) PAR factor can be used from conducted measurement and subtracted from radiated ERP PK-value.

Op. Mode 2, Set-up 1

Channel/ Frequency (MHz)		Peak Output Power (dBm)		Antenna Polarisation for maximum Power	Verdict	
		PK	AV			
GSM 1900	Channel 512/ 1850.2 MHz	27.40	1.)	EIRP-Value	V/H	Passed
	Channel 661/ 1880.0 MHz	27.22				
	Channel 810/ 1909.8 MHz	27.61				
E-GPRS 1900	Channel 512/ 1850.2 MHz	Not supported mode	1.)	EIRP-Value	V/H	--
	Channel 661/ 1880.0 MHz					
	Channel 810/ 1909.8 MHz					

Remark: -

1.) PAR factor can be used from conducted measurement and subtracted from radiated EIRP PK-value.

AMBIENT ENVIRONMENTAL CONDITIONS

Temperature	24.9 °C
Relative Humidity	29 %
Air pressure	1004 hPa

TEST EQUIPMENT

Used equipment at FAR system[Ref. No.443] (see reference in the annex)
549, 443, 439, 264, 460

5.2. Emission limits (Spurious emission conducted/radiated)

REFERENCES

FCC: §2.1051-conducted, §2.1053(a)-radiated, §22.917(a)(b); §24.238(a)(b), §2.1057(a)(1)

IC: RSS-132: 4.5.1.1, RSS-133: 6.5.1(a)(i) - TX-mode

„the power of emissions shall be attenuated below the transmitter output power (p) by at least $43+10\log(P)$ dB“

FREQUENCY RANGE

TX: The spectrum was scanned from 30 MHz to the 10th harmonic of the highest frequency generated within the equipment. The detector used was Peak.

Limit TX: The specification that all emissions shall be attenuated below the transmitter power (P) by at least $43 + 10 \log (P)$ dB, translates in the relevant power range of the mobile phone (1 to 0.001 W) to a constant limit of -13 dBm.

DESCRIPTION OF SET-UP

- see conducted set-up in chapter 4.1
- see radiated set-up in chapter 4.2

SETTINGS ON MOBILE PHONE

- The measurements in TX-mode were made at the upper, middle, and lower carrier frequencies of the operating band. Choosing three representative TX-carrier frequencies of the mobile phone within each operable GSM band, should be sufficient to demonstrate compliance with the emissions limits outside and adjacent to the frequency blocks.
- The measurements in RX-Mode were made at the middle tuning range of the receiver.
- The individual settings on base station and mobile phone were made according chapter 3.7

TEST METHOD RADIATED:

By rotating the EUT in three orthogonal planes, the emissions were recorded with Peak-Detector and Hold-Max function of the spectrum-analyzer. If the harmonic could not be detected above the noise floor, the ambient level was recorded. Measurement distance is 3m for frequencies up to 18GHz and 1m for frequencies greater than 18GHz. The readings on the spectrum analyzer are corrected with annually performed chamber path calibration values (see chapter 7), so the readings shown are equivalent to ERP/EIRP values. Critical measurements near the limit, are re-measured with a substitution method accord. ANSI/TIA/EIA 603.

SETTINGS OF SPECTRUM-ANALYSER

Frequency range	RBW (resolution bandwidth)	VBW (video bandwidth)
BAND-EDGE compliance: 1MHz immediately adjacent to the frequency blocks	1% from applicants stated/measured emission bandwidth	3..10 times the RBW
More than 1 MHz outside and adjacent the frequency blocks	1 MHz	3..10 MHz

RESULTS (CONDUCTED)

No tested, see initial tests and test report for results.

RESULTS (RADIATED)

5.2.1. GSM 850 Mode: Set-up 1, Op. Mode 1

Lowest channel: 128 (only band-edge tests and harmonic range tested)

Transmitting channel/ frequency: TX = 824.2 MHz							
Sweep frequency range: [MHz]	Diagram numbers	Remarkable highest peak found at [MHz]	Worst-Antenna Polarisation	Transducer	Result [dBm]	Limit [dBm]	Verdict
Sweep 1	--	--	--	--	--	-13.0	-- ^{4.)}
Sweep 2	8.03/8.04	823.98	H	--	<-23.19		Passed ^{3.)}
Sweep 4	--	--	V	--	--		-- ^{4.)}
Sweep 5	8.11/8.12	--	H/V	--	<-30.0		Passed ^{1.)}

Remarks: see diagrams enclosed in annex A1, only worst-case polarisation mentioned

- 1.) only results near 20dB to the limit are referenced or noise level
- 3.) Band-Edge compliance
- 4.) Compare initial test for results

Middle channel: 192

Transmitting channel/ frequency: TX = 837 MHz							
Sweep frequency range: [MHz]	Diagram numbers	Remarkable highest peak found at [MHz]	Worst-Antenna Polarisation	Transducer	Result [dBm]	Limit [dBm]	Verdict
Sweep 1	8.01/8.02	--	H/V	--	<-28.0	-13.0	Passed ^{1.)}
Sweep 4	8.07/8.08	2251.7 2428.5	H V	--	-22.89 -21.62		Passed
Sweep 5	8.09/ 8.10	3334.6	HV	--	<-43.14		Passed ^{1.)}

Remarks: see diagrams enclosed in annex A1, only worst-case polarisation mentioned

- 1.) only results near 20dB to the limit are referenced or noise level

Highest channel: 251 (only band-edge tests and harmonic range tested)

Transmitting channel/ frequency: TX = 849.8 MHz							
Sweep frequency range: [MHz]	Diagram numbers	Remarkable highest peak found at [MHz]	Worst-Antenna Polarisation	Transducer	Result [dBm]	Limit [dBm]	Verdict
Sweep 1	--	--	--	--	--	-13.0	-- ^{4.)}
Sweep 3	8.05/8.06	849.02	H	-	< -18.46		Passed ^{3.)}
Sweep 4	--	--	--	--	--		--
Sweep 5	8.13/8.14	--	H/V	--	<-30.0		Passed ^{1.)+4.)}

Remarks: see diagrams enclosed in annex A1, only worst-case polarisation mentioned

- 1.) only results near 20dB to the limit are referenced or noise level
- 3.) Band-Edge compliance
- 4.) Compare initial test for results

5.2.0.1. GSM 1900 Mode: Set-up 1, Op. Mode 2

Lowest channel: 512 (only band-edge tests and harmonics tested)

Transmitting channel/ frequency: TX = 1850,2 MHz							
Sweep frequency range: [MHz]	Diagram numbers	Remarkable highest peak found at [MHz]	Worst-Antenna Polarisation	Transducer factor [dB]	Result [dBm]	Limit [dBm]	Verdict
Sweep 1	--	--	--	--	--	-13	-- ^{6.)}
Sweep 2 ^{2.)}	--	--	--	--	--		-- ^{6.)}
Sweep 3 ^{4.)}	8.19/8.20	1.850	V	--	-32.76		Passed ^{4.)}
Sweep 5	--	--	--	--	--		-- ^{6.)}
Sweep 6	8.27/8.28	3684.9	V	--	-42.78		Passed
Sweep 7 ^{5.)}	--	--	--	--	--		-- ^{6.)}

Remark: see diagrams in annex 1 for more details, only worst-case polarisation mentioned

- 1.) only results near 20dB to the limit are referenced or noise level
- 2.) TX-carrier on diagram
- 4.) Band-Edge compliance
- 5.) overview measurement only
- 6.) compare initial test report for results

Middle channel: 661

Transmitting channel/ frequency: TX = 1880,0 MHz							
Sweep frequency range: [MHz]	Diagram numbers	Remarkable highest peak found at [MHz]	Worst-Antenna Polarisation	Transducer factor [dB]	Result [dBm]	Limit [dBm]	Verdict
Sweep 1	8.15/8.16	743.41	H/V	--	< -30	-13	Passed ^{1.)}
Sweep 2	8.17/8.18	2424.8	V	--	-19.32		Passed ^{2.)}
Sweep 5	8.23/8.24	3758.5	V	--	-40.74		Passed
Sweep 6	8.25/8.26	17435.0	V	--	< -23.50		Passed ^{1.)}
Sweep 7 ^{5.)}	--	--	--	--	--		-- ^{6.)}

Remark: see diagrams in annex 1 for more details, only worst-case polarisation mentioned

- 1.) only results near 20dB to the limit are referenced or noise level
- 2.) TX-carrier on diagram
- 5.) overview measurement only
- 6.) compare initial test report for results

Highest channel: 810 (only band-edge tests and harmonics tested)

Transmitting channel/ frequency: TX = 1908,8 MHz							
Sweep frequency range: [MHz]	Diagram numbers	Remarkable highest peak found at [MHz]	Worst-Antenna Polarisation	Transducer factor [dB]	Result [dBm]	Limit [dBm]	Verdict
Sweep 1	--	--	--	--	--	-13	-- ^{6.)}
Sweep 2	--	--	--	--	--		-- ^{6.)}
Sweep 4	8.21/8.22	1910.0	H	--	-29.58		Passed ^{4.)}
Sweep 5	--	--	--	--	--		-- ^{6.)}
Sweep 6	8.29/8.30	3814.0	V	--	-39.49		Passed
Sweep 7 ^{5.)}	--	--	--	--	--		-- ^{6.)}

Remark: see diagrams in annex 1 for more details, only worst-case polarisation mentioned

- 1.) only results near 20dB to the limit are referenced or noise level
- 2.) TX-carrier on diagram
- 4.) Band-Edge compliance
- 5.) overview measurement only
- 6.) compare initial test report for results

AMBIENT ENVIRONMENTAL CONDITIONS

Temperature	24,9 °C
Relative Humidity	29 %
Air pressure	1004 hPa

TEST EQUIPMENT

Used equipment at FAR system [ref. no. 443] (see reference in the annex)
549, 087, 264 , 439

6. Calibration method of anechoic chamber

For non-critical frequencies a pre-calibration method was used for determining the relevant radiated field-strength of radiated spurious in the anechoic chamber.

Generally the measured value is influenced by the characteristics of the used cables, filters, antenna, but also by the characteristic of the anechoic chamber.

By defining a *transducer* value, which include all characteristics of the signal propagation path (used equipment, cables, properties of anechoic chamber, etc..) from the source of radiation to the final reading equipment (spectrum-analyzer), the measured value can be corrected in order to get the real value of the device under test.

The method resumes as follows:

- 1.) determination of the path-loss of all cables used on the TX- and RX-side, which are used for the radiated measurement in the specific set-up for 1 meter and 3 meter distance.
- 2.) connection of the cables to the relevant antennas used for calibration.
- 3.) determination of the *space attenuation loss* (*G*) in the anechoic-chamber for both horizontal and vertical antenna polarisations:

A signal generator connected to the TX-antenna sweeps the frequency range of interest (30 MHz to 19.5 GHz) with a level of -30dBm - the readings on the RX-side on the spectrum analyzer gives the *space attenuation loss*. The distance between RX- and TX-antenna is 3 meter for frequencies below 18 GHz, and 1 meter for frequencies above 18 GHz.

- 4.) Mathematical determination of the frequency dependant transducer values ($TD_{H/V}$):

$$TD_{H/V} = G_{H/V} + B_{H/V} - 10 \cdot \log_{10}(1,64) + D + E - F$$

Abbreviations:

$TD_{H/V} = \lambda/2$ transducer values for horizontal /vertical antenna polarisations

$G_{H/V}$ = space attenuation loss horizontal/ vertical

$B_{H/V}$ = Gain of TX-antenna

$10 \cdot \log_{10}(1,64)$ = Gain in dB of $\lambda/2$ Dipole relative to isotropic radiator

D = insertion losses of RX cable

E = Loss of filters in signal path (not used for FCC measurements)

F = Gain of pre-amplifiers in signal path

- 5.) The transducer values are recorded for horizontal and vertical polarisations in two reference distances to the measurement antenna (1 meter and 3 meter). EIRP can be calculated from ERP by adding the gain of the lambda/2 dipole $EIRP = ERP + 2.14 \text{ dBi}$
- 6.) The specific transducer tables are loaded in the spectrum analyzer after each measurement. The readings on the spectrum-analyzer are automatically corrected by this values and can directly be compared with the limits as given in the relevant standards. The loaded values are displayed in each diagram and can be compared to internal calibration documents annually performed.

Used equipment for calibration (3 meter distance)

Used equipment (see reference)

264, 549, 020, 140, 484, 439,

Used equipment for calibration (1 meter distance)

Used equipment (see reference)

302, 303, 140, 264

7. Measurement uncertainties

The reported uncertainties are calculated based on the standard uncertainty multiplied with the appropriate coverage factor **k**, such that a confidence level of approximately 95% is achieved.

For uncertainty determination, each component used in the concrete measurement set-up was taken in account and it's contribution to the overall uncertainty according it's statistical distribution calculated.

Following table shows expectable uncertainties for each measurement type performed.

Measurement	Frequency range	Calculated uncertainty based on a confidence level of 95%	Remarks:
RF-Power Output conducted	9 kHz .. 20 GHz	1.0 dB	--
RF-Power Output radiated	30 MHz .. 4 GHz	3.17 dB	Substitution method
Conducted RF-emissions on antenna ports	9 kHz .. 20 GHz	1.0 dB	--
Radiated RF-emissions enclosure	150 kHz .. 30 MHz	5.0 dB	Magnetic field
	30 MHz .. 1 GHz	4.2 dB	E-Field
	1 GHz .. 18GHz	4.8 dB	E-Field
	1 GHz .. 20 GHz	3.17 dB	Substitution method
Occupied bandwidth	9 kHz .. 4 GHz	0.1272 ppm (Delta Marker method)	Frequency error
		1 dB	Power
Emission bandwidth	9 kHz .. 4 GHz	0.1272 ppm (Delta Marker method)	Frequency error
		1 dB	Power
Frequency stability	9 kHz .. 20 GHz	0.0636 ppm	--
Conducted emissions on AC-mains port (U _{CISPR})	9 kHz .. 150 kHz	4.0 dB	--
	150 kHz .. 30 MHz	3.6 dB	

Table : measurement uncertainties, valid for conducted/radiated measurements

8. Instruments and Ancillary

8.1. Used equipment “CTC”

The “Ref.-No” in the left column of the following tables allows the clear identification of the laboratory equipment.

8.1.1. Test software and firmware of equipment

Ref.-No.	Equipment	Type	Serial-No.	Version of Firmware or Software during the test
001	emi test receiver	ESS	825132/017	Firm.= 1.21 , OTP=2.0, GRA=2.0
012	signal generator (EMS-cond.)	SMY 01	839069/027	Firm.= V 2.02
013	power meter (EMS cond.)	NRVD	839111/003	Firm.= V 1.51
017	Communication Tester	CMD 60 M	844365/014	Firmware = V 3.52 .22.01.99, DECT Firmware D2.87
053	audio analyzer	UPA3	860612/022	Firm. V 4.3
119	RT harmonics analyser/dig. flickermeter	B10	G60547	Firm.= V 3.1DHG
140	signal generator	SMHU	831314/006	Firm.= 3.21
261	thermal power sensor	NRV-Z55	825083/0008	EPROM-Datum 02.12.04, SE EE 1 B
262	power meter	NRV-S	825770/0010	Firm.= 2.6
263	signal generator	SMP 04	826190/0007	Firm.=3.21
264	spectrum analyzer	FSEK 30	826939/005	Bios=2.1, Analyzer= 3.20
295	Racal Digital Radio Test Set	6103	1572	UNIT Firmware= 4.04, SW-Main=4.04, SW-BBP=1.04,
298	Univ. Radio Communication Tester	CMU 200	832221/091	R&S Test Firmware =3.53 /3.54 (current Testsoftw. f.
323	Communication Tester	CMD 055	825878/0034	Firm.= 3.52 .22.01.99
331	climatic test chamber -40/+80 Grad	HC 4055	43146	TSI 1.53
335	System-CTC-EMS-Conducted	System EMS Conducted	-	EMS-K1 Immunity Test-Software 1.20SR10
340	Univ. Communication Tester	CMD 55	849709/037	Firm.= 3.52 .22.01.99
355	power meter	URV 5	891310/027	Firm.= 1.31
365	10V Insertion Unit 50 Ohm	URV5-Z2	100880	Eprom Data = 31.03.08
366	Ultra Compact Simulator	UCS 500 M4	V0531100594	Firm. UCS 500=001925/3.06a02, rc=ISMIEC 4.10
371	Bluetooth Tester	CBT32	100153	CBT V5.30+ SW-Option K55
377	emi test receiver	ESCS 30	100160	Firm.= 2.30, OTP= 02.01, GRA= 02.36
378	broadband RF field monitor	RadiSense III	03D00013SNO-08	Firm.= V.03D13
383	signal generator	SME 03	842 828 /034	Firm.= 4.61
389	digital multimeter	Keithley 2000	0583926	Firm. = A13 (Mainboard) A02 (Display)
392	Radio Communication Tester	MT8820A	6K00000788	Firm.= 4.50 #005, IPL=4.01#001,OS=4.02#001,
441	System CTC-SAR-EMI Cable Loss	System EMI field (SAR)	-	EMC 32 Version 8.40
442	System CTC-SAR-EMS	System EMS field (SAR)	-	EMC 32 Version 8.40
443	System CTC-FAR-EMI-Spuri	System CTC-FAR-EMI-	-	Spuri 7.2.5
444	System CTC FAR-EMS	System EMS-Field (FAR)	-	EMS-K1 Immunity-Software 1.20SR10
460	Univ. Radio Communication Tester	CMU 200	108901	R&S Test Firmware Base=5.14/Messsoftware=
489	emi test receiver	ESU40	1000-30	Firmware=4.43 SP3, Bios=V5.1-16-3,
491	ESD Simulator dito	ESD dito	dito307022	V 2.30
524	Voltage Drop Simulator	VDS 200	0196-16	Software Nr: 000037 Version V4.20a01
526	Burst Generator	EFT 200 A	0496-06	Software Nr. 000034 Version V2.32
527	Micro Pulse Generator	MPG 200 B	0496-05	Software-Nr. 000030 Version V2.43
528	Load Dump Simulator	LD 200B	0496-06	Software-Nr. 000031 Version V2.35a01
547	Univ. Radio Kommunikation Tester	CMU 200	835390/014	R&S Test Firmware Base=V5.1403 (current Testsoftw.
584	Spectrum Analyzer	FSU 8	100248	2.82 SP3
594	Communication Tester	CMW500	101757	Firmware Base=2.0.20.9, LTE=2.0.20.8. CDMA= 2.0.10
597	Univ. Radio Communication Tester	CMU 200	100347	R&S Test Firmware Base=5.01 /Messsoftware=
598	Spectrum Analyser	FSEM 30 (Reserve)	831259/013	Firmware Bios 3.40 , Analyzer 3.40 Sp 2

8.1.2. Single instruments and test systems

Ref.-No.	Equipment	Type	Serial-No.	Manufacturer	Interval of calibration	Remark	Cal due
001	emi test receiver	ESS	825132/017	Rohde & Schwarz	12 M	-	31.03.2012
005	AC - LISN (50 Ohm/50µH, test site 1)	ESH2-Z5	861741/005	Rohde & Schwarz	24/12 M	-	31.03.2012
007	DC - LISN (50 Ohm/5µH)	ESH3-Z6	892563/002	Rohde & Schwarz	24/12 M	-	31.03.2012
009	power meter (EMS-radiated)	NRV	863056/017	Rohde & Schwarz	24 M	-	31.03.2013
016	line impedance simulating network	Op. 24-D	B6366	Spitzenberger+Spies	36 M	-	31.03.2013
020	horn antenna 18 GHz (Subst 1)	3115	9107-3699	EMCO	36/12 M	-	31.03.2013
021	loop antenna (H-Field)	6502	9206-2770	EMCO	36 M	-	31.03.2013
030	loop antenna (H-field)	HFH-Z2	879604/026	Rohde & Schwarz	36 M	-	31.03.2012
033	RF-current probe (100kHz-30MHz)	ESH2-Z1	879581/18	Rohde & Schwarz	24 M	-	31.03.2013
060	power amplifier (DC-2kHz)	PAS 5000	B6363	Spitzenberger+Spies	-	3	
066	notch filter (WCDMA; FDD1)	WRCT 1900/2200-5/40-	5	Wainwright GmbH	12 M	-	30.05.2011
086	DC - power supply, 0 -10 A	LNG 50-10	-	Heinzinger Electronic	pre-m	2	
087	DC - power supply, 0 -5 A	EA-3013 S	-	Elektro Automatik	pre-m	2	
090	Helmholtz coil: 2x10 coils in series	-	-	RWTÜV	pre-m	4	
091	USB-LWL-Converter	OLS-1	007/2006	Ing. Büro Scheiba	-	4	
099	passive voltage probe	ESH2-Z3	299.7810.52	Rohde & Schwarz	36 M	-	31.03.2012
100	passive voltage probe	Probe TK 9416	without	Schwarzbeck	36 M	-	31.03.2012
110	USB-LWL-Converter	OLS-1	-	Extreme USB	-	4	
119	RT harmonics analyser/dig. flickermeter	B10	G60547	BOCONSULT	36 M	-	31.03.2013
134	horn antenna 18 GHz (Subst 2)	3115	9005-3414	EMCO	12 M	-	31.03.2012
136	adjustable dipole antenna (Dipole 1)	3121C-DB4	9105-0697	EMCO	12 M	-	31.03.2012
140	signal generator	SMHU	831314/006	Rohde & Schwarz	24 M	-	31.03.2012
248	attenuator	SMA 6dB 2W	-	Radiall	pre-m	2	
249	attenuator	SMA 10dB 10W	-	Radiall	pre-m	2	
252	attenuator	N 6dB 12W	-	Radiall	pre-m	2	
256	attenuator	SMA 3dB 2W	-	Radiall	pre-m	2	
257	hybrid	4031C	04491	Narda	pre-m	2	
260	hybrid coupler	4032C	11342	Narda	pre-m	2	
261	thermal power sensor	NRV-Z55	825083/0008	Rohde & Schwarz	24/12 M	-	31.03.2012
262	power meter	NRV-S	825770/0010	Rohde & Schwarz	24 M	-	31.03.2012
263	signal generator	SMP 04	826190/0007	Rohde & Schwarz	36 M	-	31.03.2013
264	spectrum analyzer	FSEK 30	826939/005	Rohde & Schwarz	12 M	-	31.03.2014
265	peak power sensor	NRV-Z33, Model 04	840414/009	Rohde & Schwarz	24 M	-	31.03.2012
266	peak power sensor	NRV-Z31, Model 04	843383/016	Rohde & Schwarz	24 M	-	31.03.2012
268	AC/DC power supply	EA 3050-A	9823636	-	pre-m	2	
270	termination	1418 N	BB6935	Weinschel	pre-m	2	
271	termination	1418 N	BE6384	Weinschel	pre-m	2	
272	attenuator (20 dB) 50 W	Model 47	BF6239	Weinschel	pre-m	2	
273	attenuator, (10 dB) 100 W	Model 48	BF9229	Weinschel	pre-m	2	
274	attenuator (10 dB) 50 W	Model 47 (10 dB) 50 W	BG0321	Weinschel	pre-m	2	
275	DC-Block	Model 7003 (N)	C5129	Weinschel	pre-m	2	
276	DC-Block	Model 7006 (SMA)	C7061	Weinschel	pre-m	2	
279	power divider	1515 (SMA)	LH855	Weinschel	pre-m	2	
287	pre-amplifier 25MHz - 4GHz	AMF-2D-100M4G-35-10P	379418	Miteq	12 M	-	30.05.2011
291	high pass filter GSM 850/900	WHJ 2200-4EE	14	Wainwright GmbH	12 M	-	30.05.2011
298	Univ. Radio Communication Tester	CMU 200	832221/091	Rohde & Schwarz	pre-m	-	
300	AC LISN (50 Ohm/50µH, 1-phase)	ESH3-Z5	892 239/020	Rohde & Schwarz	24/12 M	-	31.03.2012
301	attenuator (20 dB) 50W, 18GHz	47-20-33	AW0272	Lucas Weinschel	pre-m	2	
302	horn antenna 40 GHz (Meas 1)	BBHA9170	155	Schwarzbeck	36 M	-	31.03.2014
303	horn antenna 40 GHz (Subst 1)	BBHA9170	156	Schwarzbeck	36 M	-	31.03.2014
331	climatic test chamber -40/+80 Grad	HC 4055	43146	Heraeus Vötsch	24 M	-	30.11.2012
341	digital multimeter	Fluke 112	81650455	Fluke	24 M	-	31.03.2012
342	digital multimeter	Voltcraft M-4660A	1B 255466	Voltcraft	24 M	-	31.03.2013
347	laboratory site	radio lab.	-	-	-	3	
348	laboratory site	EMI conducted	-	-	-	3	
354	DC - power supply 40A	NGPE 40/40	448	Rohde & Schwarz	pre-m	-	
355	power meter	URV 5	891310/027	Rohde & Schwarz	24 M	-	31.03.2012
356	power sensor	NRV-Z1	882322/014	Rohde & Schwarz	24 M	-	31.03.2013
357	power sensor	NRV-Z1	861761/002	Rohde & Schwarz	24 M	-	31.03.2013
373	V-Network 5µH/50 Ohm	ESH3-Z6	100535	Rohde & Schwarz	24/12 M	-	31.03.2012
376	horn antenna 6 GHz	BBHA9120 E	BBHA 9120 E 179	Schwarzbeck	12 M	-	31.03.2012
377	emi test receiver	ESCS 30	100160	Rohde & Schwarz	12 M	-	31.03.2012
389	digital multimeter	Keithley 2000	0583926	Keithley	24 M	-	31.03.2013
392	Radio Communication Tester	MT8820A	6K00000788	Anritsu	12 M	-	31.03.2012
431	Model 7405	Near-Field Probe Set	9305-2457	EMCO	-	4	
439	UltraLog-Antenna	HL 562	100248	Rohde & Schwarz	12 M	-	30.05.2011
441	System CTC-SAR-EMI Cable Loss	System EMI field (SAR)	-	ETS	12 M	5	31.08.2011
443	System CTC-FAR-EMI-Spuri	System CTC-FAR-EMI-	-	ETS-Lindgren/Cetecom	12 M	5	30.06.2011
448	notch filter WCDMA FDD II	WRCT 1850.0/2170.0-	5	Wainwright Instruments	12 M	1c	30.05.2011
449	notch filter WCDMA FDD V	WRCT 824.0/894.0-5/40-	1	Wainwright Instruments	12 M	1c	30.05.2011

454	Oscilloscope	HM 205-3	9210 P 29661	Hameg	-	4	
456	DC-Power supply 0-5A	EA 3013 S	207810	Elektro Automatik	pre-m	2	
459	DC -power supply 0-5 A , 0-32 V	EA-PS 2032-50	910722	Elektro Automatik	pre-m	2	
460	Univ. Radio Communication Tester	CMU 200	108901	Rohde & Schwarz	12 M	-	31.03.2012
463	Universal source	HP3245A	2831 A03472	Agilent	-	4	
466	digital multimeter	Fluke 112	89210157	Fluke USA	24 M	-	31.03.2012
467	digital multimeter	Fluke 112	89680306	Fluke USA	24 M	-	31.03.2012
468	digital multimeter	Fluke 112	90090455	Fluke USA	24 M	-	31.03.2012
477	ReRadiating GPS-System	AS-47	-	Automotive Cons. Fink	-	3	
480	power meter (Fula)	NRVS	838392/031	Rohde & Schwarz	24 M	-	31.03.2013
482	filtermatrix	FilterMatrix SAR 1	-	CETECOM (Brl)	-	1d	
484	pre-amplifier 2,5 - 18 GHz	AMF-5D-02501800-25-	1244554	Miteq	12 M	-	01.06.2011
487	System CTC NSA-Verification SAR-EMI	System EMI field (SAR)	-	ETS	12 M	-	30.09.2011
489	emi test receiver	ESU40	1000-30	Rohde & Schwarz	12 M	-	31.03.2012
502	band reject filter	WRCG 1709/1786-	SN 9	Wainwright	-	2	
503	band reject filter	WRCG 824/849-814/859-	SN 5	Wainwright	-	2	
517	relais switc matrix	HF Relais Box Keithley	SE 04	Keithley	-	2	
523	Digitalmultimeter	L4411A	MY46000154	Agilent	24 M	-	31.03.2013
529	6 dB Broadband resistive power divider	Model 1515	LH 855	Weinschel	pre-m	2	
530	10 dB Broadband resistive power divider	R 416110000	LOT 9828	-	pre-m	2	
547	Univ. Radio Kommunikation Tester	CMU 200	835390/014	Rohde & Schwarz	12 M	-	31.03.2012
548	Digital-Barometer	GBP 2300	without	Greisinger GmbH	36/12 M	-	31.03.2012
549	Log.Per-Antenna	HL025	1000060	Rohde & Schwarz	36/12 M	-	31.03.2012
552	high pass filter 2.8-18GHz	WHKX 2.8/18G-10SS	4	Wainwright	12 M	-	30.06.2011
558	System CTC FAR S-VSWR	System CTC FAR S-	-	CTC	24 M	-	31.08.2011
574	Biconilog Hybrid Antenna	BTA-L	980026L	Frankonia	36/12 M	-	30.03.2013
584	Spectrum Analyzer	FSU 8	100248	Rohde & Schwarz	12 M	-	31.03.2012
594	Communication Tester	CMW500	101757	Rohde & Schwarz	24 M	-	31.03.2012
597	Univ. Radio Communication Tester	CMU 200	100347	Rohde & Schwarz	12 M	-	31.03.2012
598	Spectrum Analyser	FSEM 30 (Reserve)	831259/013	Rohde & Schwarz	24 M	-	13.01.2013
600	power meter	NRVD (Reserve)	834501/018	Rohde & Schwarz	24 M	-	31.03.2013
601	medium-sensitivity diode sensor	NRV-Z5 (Reserve)	8435323/003	Rohde & Schwarz	24 M	-	12.01.2013
602	peak power sensor	NRV-Z32 (Reserve)	835080	Rohde & Schwarz	24 M	-	12.01.2013
608	UltraLog-Antenna	HL 562	830547/009	Rohde & Schwarz	36/12 M	-	31.05.2014
611	DC power supply	E3632A	KR 75305854	Agilent	pre-m	2	
612	DC power supply	E3632A	MY 40001321	Agilent	pre-m	2	
613	Attenuator	R416120000 20dB 10W	Lot. 9828	Radiall	pre-m	2	

8.1.3. Legend

Note / remarks		Calibrated during system calibration:
	1a	System CTC-SAR-EMS (Ref.-No. 442)
	1b	System-CTC-EMS-Conducted (Ref.-No. 335)
	1c	System CTC-FAR-EMI-spurious emission (Ref.-No . 443)
	1d	System CTC-SAR-EMI (Ref.-No . 441)
	1e	System CTC-OATS (EMI radiated) (Ref.-No. 337)
	1 f	System CTC-CTIA-OTA (Ref.-No . 420)
	1 g	System CTC-FAR-EMS (Ref.-No . 444)
	2	Calibration or equipment check immediately before measurement
	3	Regulatory maintained equipment for functional check or support purpose,
	4	Ancillary equipment without calibration e.g. mechanical equipment or monitoring equipment
	5	Test System

Interval of calibration	12 M	12 month
	24 M	24 month
	36 M	36 month
	24/12 M	Calibration every 24 months, between this every 12 months internal validation
	36/12 M	Calibration every 36 months, between this every 12 months internal validation
	Pre-m	Check before starting the measurement
	-	Without calibration

TEST REPORT
 No.: 2-20795542c/11

According to:
FCC Regulations
 FCC Part 15B
 &
IC Regulations
 RSS-Gen, Issue 2
 RSS-132, Issue 2
 RSS-133, Issue 5

for

Cinterion Wireless Modules GmbH

Quad-Band GSM/GPRS Module BGS2-W
 FCC-ID: QIPBGS2
 IC: 7830A-BGS2







Laboratory Accreditation and Listings			
 D-PL-12047-01-01	 MRA US-EU 0003	 Industry Canada Reg. No.: 3462D-1 3462D-2	 Reg. No.: R-2665, R-2666 C-2914, T-1967 G-301
 LAB CODE 20011130-00	 	accredited according to DIN EN ISO/IEC 17025	
CETECOM GmbH Laboratory Radio Communications & Electromagnetic Compatibility Im Teelbruch 116 • 45219 Essen • Germany Registered in Essen, Germany, Reg. No.: HRB Essen 8984 Tel.: + 49 (0) 20 54 / 95 19-954 • Fax: + 49 (0) 20 54 / 95 19-964 E-mail: info@cetecom.com • Internet: www.cetecom.com			

Table of contents

1. SUMMARY OF TEST RESULTS.....	3
1.1. TESTS OVERVIEW FCC Part 15 and Kanada IC Standards (RSS-Gen)	3
2. ADMINISTRATIVE DATA	4
2.1. Identification of the testing laboratory	4
2.2. Test location	4
2.3. Organizational items	4
2.4. Applicant’s details	4
2.5. Manufacturer’s details	4
3. EQUIPMENT UNDER TEST (EUT).....	5
3.1. Additional declaration and description of main EUT	5
3.2. Configuration of cables used for testing	5
3.3. EUT: Type, S/N etc. and short descriptions used in this test report	6
3.4. Auxiliary Equipment (AE): Type, S/N etc. and short descriptions.....	6
3.5. EUT set-ups	7
3.6. EUT operating modes	7
3.7. Configuration of cables used for testing	7
3.8. Parameter Settings on mobile phone and base station CMU200	8
4. MEASUREMENTS	9
4.1. Conducted emissions on antenna port (RX-Mode).....	9
4.2. Conducted emissions on antenna port, §15.111.....	10
4.3. Conducted emissions on antenna port, Canada requirements, RSS-132, Issue 2, §4.6.....	10
4.4. Conducted emissions on antenna port, Canada requirements, RSS-133, Issue 3, §6.7(b).....	10
4.5. Conducted emissions on AC-Power lines.....	11
4.6. Radiated emissions, 30 MHz - 1 GHz, §15.109 class B, RSS132, RSS133, RSS-gen	13
4.7. Radiated emissions, above 1GHz, §15.109 class B, RSS132, RSS133, RSS-gen	15
5. MEASUREMENT UNCERTAINTIES.....	18
6. INSTRUMENTS AND ANCILLARY.....	19
6.1. Used equipment “CTC”	19

Table of annex

Total pages

SEPARATE DOCUMENT 2_20795542C_10_A1.PDF: DIAGRAMS OF TESTING	24
SEPARATE DOCUMENT 2_20795542C_10_A2.PDF: PHOTOS OF TEST SET-UP	3

1. Summary of test results

The presented GSM 850/900/1800/1900 Module can be build inside host applications and extends their capability by wireless GSM technology. Data transmissions or voice applications are possible field applications.

In order to verify the compliance with applicable rules, a representative configuration consisting of representative auxiliary equipment was chosen. Embedded in this configuration, the GSM Module can be tested. Pls. refer to set-up description and photos for more details.

Following tests have been performed to show compliance with applicable FCC Part 15B and IC-regulations RSS-Gen., RSS-132 and RSS-133.

The test results apply exclusively to the test samples as presented in chapter 3.1. The CETECOM GmbH does not assume responsibility for any conclusions and generalizations taken in conjunction with other specimens or samples of the type of the item presented to tests.

1.1. TESTS OVERVIEW FCC Part 15B and Kanada IC Standards (RSS-Gen)

TEST CASES	PORT	REFERENCES & LIMITS			EUT set-up	EUT operating mode	Result
		FCC Standard	RSS Section	TEST LIMIT			
RX Mode							
AC-Power Lines Conducted Emissions	AC-Power lines	§15.107	RSS-Gen, Issue 2: Chapter 7.2.2	FCC §15.107 class B limits §15.207 limits IC: Table 2, Chapter 7.2.2	3	1+2	Passed
RECEIVER Radiated emissions	Cabinet + Interconnecting cables (radiated)	§15.109 §15.33 §15.35	RSS-132, Issue 2: 4.6 RSS-Gen, Issue 2: 6(a) RSS-133, Issue 5: 6.6	FCC 15.109 class B limits IC-limits: Table 1, Chapter 6	1	1+2	Passed
RECEIVER Conducted emissions	Antenna terminal (conducted)	§2.1051 §15.111(a)	RSS-Gen: 6(b) RSS-132, Issue 2: 4.6 RSS-133, Issue 5: 6.6	FCC: < 2nW IC: < 2 nW/4kHz (30<f<1000MHz) < 5nW/4kHz (f> 1GHz)	2	1+2	Passed

Remark:

See separate test report 2_20795542b/11 for measurements according FCC Part 22/24 (IC RSS-132/133)

ATTESTATION:

I declare that all measurements were performed by me or under my supervision and that all measurements have been performed and are correct to my best knowledge and belief to Industry Canada standards. All requirements as shown in above table are met in accordance with enumerated standards.

.....
Dipl.-Ing. W. Richter
Responsible for test section

GmbH
Im Teelbruch 116
45219 Essen
Tel: +49 (0) 20 54 7 95 19 - 0
Fax: +49 (0) 20 54 7 95 19 - 097

.....
Dipl.-Ing. C. Lorenz
Responsible for test report

2. Administrative Data

2.1. Identification of the testing laboratory

Company name:	CETECOM GmbH
Address:	Im Teelbruch 116 45219 Essen - Kettwig Germany
Laboratory accreditations/Listings:	DAR-Registration No. DAT-P176/94-02 MRA US-EU 0003 IC-Registration No. 3462D-1, 3462D-2 VCCI Registration No. R-2665,R-2666,C-2914,T-339
Responsible for testing laboratory:	Dipl.-Ing. W. Richter
Deputies:	Dipl.-Ing. J. Schmitt

2.2. Test location

2.2.1. Test laboratory "CTC"

Company name:	see chapter 2.1. Identification of the testing laboratory
---------------	---

2.3. Organizational items

Order No.:	20795542
Responsible for test report and project leader:	Dipl.-Ing. C. Lorenz
Receipt of EUT:	2011-02-01
Date(s) of test:	2011-02-01 - 1
Date of report:	2011-03-01

Version of template:	09.06 _All.Dotm

2.4. Applicant's details

Applicant's name:	Cinterion Wireless Modules GmbH
Address:	Siemensdamm 50 13629 Berlin Germany
Contact person:	Mr. Stefan Ludwig

2.5. Manufacturer's details

Manufacturer's name:	please see Applicant's details
Address:	please see Applicant's details

3. Equipment under test (EUT)

3.1. Additional declaration and description of main EUT

Main function	GSM/GPRS Quad-Band Module		
Type	BGS2-W		
GSM Frequency range (USA/Canada bands)	GSM 850: 824 – 849MHz (Uplink), 869-894MHz (Downlink) GSM1900: 1850-1910MHz (Uplink), 1930-1990MHz (Downlink)		
Type of modulation	GMSK		
Number of channels (USA/Canada bands)	GSM 850: 128 – 251, 125 channels GSM1900: 512 – 810, 300 channels		
EMISSION DESIGNATOR(S)	245KGXW		
Antenna Type: External magnet mount antenna for vehicular use	<input type="checkbox"/> Integrated <input type="checkbox"/> External, no RF- connector <input checked="" type="checkbox"/> External, separate RF-connector	Frequency range: GSM 850: 824 – 894 MHz GSM 1900: 1850-1990 MHz	
Antenna Gain	<input checked="" type="checkbox"/> radiated: Max. 2 dBi gain at GSM1900		
MAX PEAK Output Power: Radiated ERP	GSM850	29,01 dBm (Burst PK)	
Radiated EIRP	GSM1900	27,60 dBm (Burst PK)	
MAX PEAK Output Power: Conducted	GSM 850	32,40 dBm (PK)	
Conducted	GSM1900	29,89 dBm (PK)	
FCC-ID	QIPBGS2		
IC	7380A-BGS2		
Installed option	<input checked="" type="checkbox"/> GSM900 and GSM1800 Bands		
Special EMI components	--		
Power supply	Internally supplied and controlled by the DSB75 Board for tests: $V_{MIN}=3.3V$ to $V_{MAX}=4.5V$ DSB75 Box was DC supplied with 9V external power supply		
EUT sample type	<input type="checkbox"/> Production	<input checked="" type="checkbox"/> Pre-Production	<input type="checkbox"/> Engineering

3.2. Configuration of cables used for testing

Cable number	Item	Type	S/N serial number	HW hardware status	Cable length
Cable 1	RS232	unshielded	CTC	--	1.8m
Cable 2	USB cable	shielded	CTC	--	1.5m

3.3. EUT: Type, S/N etc. and short descriptions used in this test report

Short description*)	EUT	Type	S/N serial number	HW hardware status	SW software status
EUT A	Quad-Band GSM/GPRS Module	BGS2-W	IMEI: 004401 08 048446 8	B2.1	00.960
EUT B	Magnetic Mount antenna	MAR-C3G-2F	CTC#1	2dBi Gain	--
EUT C	Handset Votronic	For M20T, MC35T, TC35T, DSB35	401795321130 4	HH-SI-30.3/V1.1/0	--
EUT D	Adapter Board for BGS2-W	Ven_60/80_0035	#1	--	--
EUT E	DSB Board + Adapter BG2_PH8_Ada_0207	DSB75	0411090 ICM-100012-03	B1.1	--
EUT F	Quad-Band GSM/GPRS Module	BGS2-W	IMEI: 004401 08 048449 2	B2.1	00.960

*) EUT short description is used to simplify the identification of the EUT in this test report.

3.4. Auxiliary Equipment (AE): Type, S/N etc. and short descriptions

AE short description *)	Auxiliary Equipment	Type	S/N serial number	HW hardware status	SW software status
AE 1	Notebook	Dell D610D	CTC PC3	--	Windows XP + Terminal Program
AE 2	AC/DC Adapter	FW7238/09	1401	Input: 100V – 240 V AC/50-60Hz/180mA Output: 9V DC/800mA	--

*) AE short description is used to simplify the identification of the auxiliary equipment in this test report.

3.5.EUT set-ups

EUT set-up no. *)	Combination of EUT and AE	Remarks
Set. 1	EUT A + EUT B + EUT C + EUT D + EUT E + AE1	AT-commands set the device into operating mode conditions with help of AE1, AE1 connected during tests after successful connection/op-mode establishment but switched off. Used for radiated measurements
Set. 2	EUT F + EUT B + EUT C + EUT D + EUT E + AE1	AT-commands set the device into operating mode conditions with help of AE1, AE1 connected during tests after successful connection/op-mode establishment but switched off. Used for conducted RF measurements
Set. 3	EUT A + EUT B + EUT C + EUT D + EUT E + AE1 + AE2	AT-commands set the device into operating mode conditions with help of AE1, AE1 connected during tests after successful connection/op-mode establishment but switched off. Used for conducted AC mains measurements

*) EUT set-up no. is used to simplify the identification of the EUT set-up in this test report.

3.6. EUT operating modes

EUT operating mode no. *)	Description of operating modes	Additional information
op. 1	GSM 850 Idle mode BCCH 182	The mobile station is synchronized to the Broadcast Control Channel (BCCH) and listening to the Common Control Channel (CCCH). Periodic location update is disabled.
op. 2	GSM 1900 Idle mode BCCH 651	The mobile station is synchronized to the Broadcast Control Channel (BCCH) and listening to the Common Control Channel (CCCH). Periodic location update is disabled.

*) EUT operating mode no. is used to simplify the test report.

3.7. Configuration of cables used for testing

Cable number	Item	Type	S/N serial number	HW hardware status	Cable length
Cable 3	RS232	unshielded	CTC	--	1.8m
Cable 4	USB cable	shielded	CTC	--	1.5m

3.8. Parameter Settings on mobile phone and base station CMU200

Following settings apply to the MS during the measurements in GSM/(E)GPRS-Mode only:

Parameter	Traffic Mode	Idle Mode
Traffic Channels mobile station (EUT)	GSM 850 TCH _{MS} = 128/ 192 /251 GSM 1900 TCH _{MS} = 512 / 681 / 810	--
maximum power level (PCL)	GSM 850: PCL = 5 (2 Watt) GSM 1900: PCL = 0 (1 Watt)	--
Modulation	GSM: GMSK-Modulation Scheme EDGE: 8-PSK Modulation Scheme	--
DTX	off	--
Bitstream	PRBS 2E9-1 (pseudo-random-sequence) – CCITT 0.153	
Timeslot	3	
Hopping	off	
Timeslot (slot mode)	GSM-Mode: single GPRS-Mode: maximum allowed uplink slots no. according MS class	
MS slot class	Class 10	
Maximum data transmission rate, single time slot	GSM: 17,6 kBit/s Slot EDGE: 59,2 kBit/s Slot	
Speech transcoding (Traffic Mode)	Full rate Version 1	
Mode	BCCH and TCH	
BCCH – base station (CMU,CMD)		GSM 850: 182 GSM 1900: 651
TCH – base station (CMD, CMU)	auto	
Power level TCH – base station (used timeslot level)	- 70 dBm	
Power level BCCH – base station (control channel level)	- 80 dBm	
External attenuation RF/AF-Input/Output	Accord. calibration prior to measurements	
Mobile Country Code	310	310
BS_AG_BLK_RES		0
Paging reorganisation		Off (0)
Signalling channel	Not applicable	SDCCH
Location Update		Auto
Cell access		Disabled (barred)

Settings for CMU (general)

Repetition	Continuous
Stop condition	None
Display mode	Max./Min
Statistic Count	1000 Bursts
Decoder	Standard

Additional settings on the base stations CMU200 for frequency stability measurements

4. Measurements

4.1. Conducted emissions on antenna port (RX-Mode)

Test location and equipment (for reference numbers please see chapter 'List of test equipment')

test location	<input checked="" type="checkbox"/> CETECOM Essen (Chapter. 2.2.1)	<input type="checkbox"/> Please see Chapter. 2.2.2	<input type="checkbox"/> Please see Chapter. 2.2.3
test site	<input type="checkbox"/> 441 EMI SAR	<input type="checkbox"/> 487 SAR NSA	<input type="checkbox"/> 337 OATS
receiver	<input type="checkbox"/> 377 ESCS30	<input type="checkbox"/> 001 ESS	<input checked="" type="checkbox"/> 347 Radio.lab.
spectr. analys.	<input type="checkbox"/> 381 380 FSBS	<input type="checkbox"/> 120 FSEM	<input type="checkbox"/> 264 FSEK
signaling	<input checked="" type="checkbox"/> 298 CMU	<input type="checkbox"/> 460 CMU	<input type="checkbox"/> 295 RACAL
power supply	<input type="checkbox"/> 456 EA 3013A	<input type="checkbox"/> 457 EA 3013A	<input type="checkbox"/> 459 EA 2032-50
otherwise	<input type="checkbox"/> 400 FTC40x15E	<input type="checkbox"/> 401 FTC40x15E	<input type="checkbox"/> 110 USB LWL

Standards and Limits: CFR 47, Part 15, Subpart B, §15.111 (a), RSS-132, RSS-133, RSS-Gen

Standard	conducted emission limits on antenna port	
	Value / [nW]	Value / [dBm]
FCC: §15.111(a)	2 nW for all frequencies	-57dBm
RSS-Gen	2 nW below 1GHz	-57 dBm
RSS-132	5 nW about 1GHz	-53 dBm
RSS-133		

Test condition and measurement test set-up

link to test system (if used):	<input type="checkbox"/> Air-link	<input checked="" type="checkbox"/> cable connection
Climatic conditions	Temperature: (23.3°C)	Rel. humidity: (37)%
EMI-Receiver (Analyzer) Settings	Span/Range: from RBW/VBW: 100 kHz below 1GHz, 1MHz above 1GHz Detector/ Mode: PEAK, TRACE max-hold mode, repetitive scan Quasi-Peak for final measurement on critical measurements (f<1GHz) Average: for final measurement on critical measurements (f>1GHz)	

GENERAL MEASUREMENT PROCEDURES:

The measurement test set-up and test procedure are in accordance with the provisions described in ANSI 63.4: 2003 (2009)

The *Equipment under Test* (EUT) set-up to defined operating mode and installed (connected) to accessory equipment according the general description of use given by the applicant.

Test Set-up for conducted measurements

The EUT's RF-signal is coupled out by a suitable antenna coupling connector (1). The signal is first 10 dB attenuated (2) before it is 0° divided by a power divider (3). One of the signal path is connected to the communication base station (4), other branch is connected to the spectrum – analyzer (5). The specific attenuation losses for both signal paths/branches are determined prior to the measurement within a set-up calibration. These are then taken into account by correcting the measurement readings on the spectrum-analyzer.

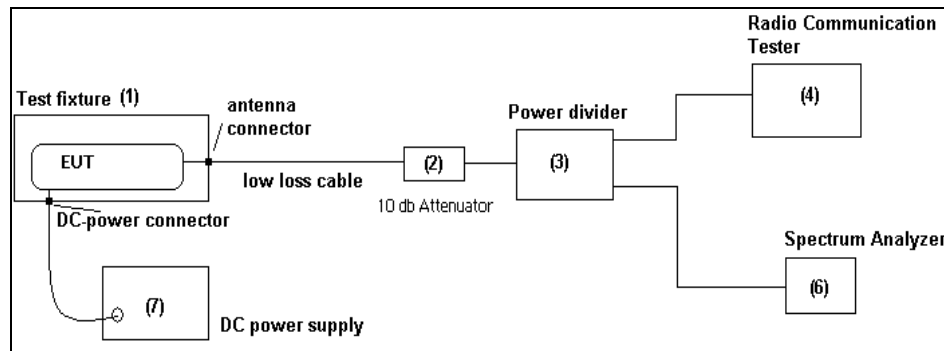

Schematic: Test set-up conducted

4.2. Conducted emissions on antenna port, §15.111

Middle RX-channel = 192 (Set-up 2, Op. Mode 1)

BCCH channel = 182 (Downlink)							
Sweep frequency range: [MHz]	Diagram number	Frequency of emission [MHz]	Transducer factor [dB]	Result /[dBm]		Limit [dBm]	Verdict
				PK	AV		
Sweep 1: 30MHz - 1GHz	14.21	178.60	1.)	-64.43	--	-57	Passed
		879.91		-44.22	--		BCCH channel 182, emission not from EUT, Passed
Sweep 2: 1GHz-5GHz	14.22 + discrete frequencies	1867.62 35669.8	--	-61.42 -63.72 -63.73	-68.77 -76.27 -76.17		Passed

Remark: see also diagrams enclosed in Annex A1 for more details

- 1.) External path correction factors counted automatically in the measurement software

4.3. Conducted emissions on antenna port, Canada requirements, RSS-132, Issue 2, §4.6

Middle RX-channel = 192 (Set-up 2, Op. Mode 1)

BCCH channel = 182 (Downlink)							
Sweep frequency range: [MHz]	Diagram number	Frequency of emission [MHz]	Transducer factor [dB]	Correction factor (RBW:3kHz-> 4kHz)	Result [dBm]	Limit [dBm]	Verdict
Sweep 1: 30..1000MHz	14.17	30-1000MHz 880.10 MHz	1.)	+ 1.25 dB	< - 86.75 dBm -53.15 remark 2.)	-57	Passed
Sweep 2: 1 .. 19.5 GHz	14.18	1-18.5GHz 3588.25 MHz	1.)		< -69.75 dBm -68.11 dBm	-53	Passed

Remark: see also diagrams enclosed in Annex A1 for more details

- 2.) Peak from measurement set-up, BCCH carrier of base station

4.4. Conducted emissions on antenna port, Canada requirements, RSS-133, Issue 3, §6.7(b)

Middle RX-channel = 661 (Set-up 2, Op. Mode 2)

BCCH channel = 651 (downlink)							
Sweep frequency range: [MHz]	Diagram number	Frequency of emission [MHz]	Transducer factor [dB]	Correction factor (RBW:3kHz-> 4kHz)	Result [dBm]	Limit [dBm]	Verdict
Sweep 1: 30..1000MHz	14.19	30-1000MHz	1.)	+ 1.25 dB	< -77.23 dBm	-57	Passed
Sweep 2: 1 .. 19.5 GHz	14.20	1-18.5GHz 12.835GHz 1957.25MHz	1.)		< -68.58 dBm -66.73 dBm -52.20 dBm	-54	Passed

Remark: see also diagrams enclosed in Annex A1 for more details

- 2.) Peak from measurement set-up, BCCH carrier of base station

Verdict

Summary of conducted measurement: Passed

4.5. Conducted emissions on AC-Power lines

TEST LOCATION AND EQUIPMENT (for reference numbers please see chapter 'List of test equipment')

test location	<input checked="" type="checkbox"/> CETECOM Essen (Chapter 2.2.1)	<input type="checkbox"/> Please see Chapter 2.2.2	<input type="checkbox"/> Please see Chapter 2.2.3
test site	<input type="checkbox"/> 333 EMI field	<input checked="" type="checkbox"/> 348 EMI cond.	<input type="checkbox"/> 334 EMS-field <input type="checkbox"/> 335 EMS cond <input type="checkbox"/> 347 Radio.lab. <input type="checkbox"/> 337 OATS
receiver	<input checked="" type="checkbox"/> 001 ESS	<input type="checkbox"/> 377 ESCS 30	<input type="checkbox"/>
LISN	<input checked="" type="checkbox"/> 005 ESH2-Z5	<input type="checkbox"/> 007 ESH3-Z6	<input type="checkbox"/> 300 ESH3-Z5 & 50Ω used for AE <input checked="" type="checkbox"/> no LISN for AE <input type="checkbox"/>
signaling	<input type="checkbox"/> 017 CMD 65	<input type="checkbox"/> 323 CMD 55	<input type="checkbox"/> 340 CMD 55
signaling	<input type="checkbox"/> 298 CMU	<input type="checkbox"/> 460 CMU	<input type="checkbox"/> 295 RACAL <input checked="" type="checkbox"/> 392 MT8820A

STANDARDS AND LIMITS: PART 15, SUBPART B, §15.107, §15.207, CANADA: RSS-GEN:7.2.2, ANSI C63.4:2009

Frequency [MHz]	Conducted limit [dBμV] Class B		Conducted limit [dBμV] Class A	
	QUASI-Peak	AVERAGE	QUASI-Peak	AVERAGE
0.15 – 0.5	66 to 56*	56 to 46*	79	66
0.5 – 5	56	46	73	60
5 – 30	60	50	73	60

Remark: * decreases with the logarithm of the frequency

TEST CONDITION AND MEASUREMENT PROCEDURES TEST SET-UP

link to test system (if used):	<input checked="" type="checkbox"/> air link <input type="checkbox"/> cable connection <input type="checkbox"/>
EUT-grounding	<input checked="" type="checkbox"/> none <input type="checkbox"/> with power supply <input type="checkbox"/> additional connection
Equipment set up	<input checked="" type="checkbox"/> table top (40 cm distance to reference ground plane (wall)) <input type="checkbox"/> floor standing EUT stands isolated on reference ground plane (floor)
Climatic conditions	Temperature: (23.7°C) Rel. humidity: (33)%
EMI-Receiver (Analyzer) Settings	Span/Range: 150 kHz to 30 MHz RBW: 9 kHz Detector/Mode: Max PEAK-hold, repetitive scan for preliminary testing Quasi-Peak Detector and Average-Detector for final measurement according ANSI 63.4, CISPR 16

Devices which can be connected to the public AC-power network, should be tested against the radio frequency voltage conducted back into the AC-power line in the frequency range 150kHz to 30 MHz. Compliance should be tested by measuring the radio frequency voltage between each power line and ground at the power terminals in the stated frequency range.

A 500hm/50μH line impedance stabilization network (LISN) is used therefore. The EUT power input leads are connected through the LISN to the AC-power source. The LISN enclosure is electrically connected to the GND-plane. The measuring instrument is connected to the coaxial output of the LISN.

Tabletop devices were set-up on a 80 cm height over reference ground plane, floor standing equipment 10 cm raised above ground plane.

Measurements have been performed on each phase line and neutral line of the devices AC-power lines. The EUT was power supplied with 110 V/60Hz.

The EUT was tested in the defined operating mode and installed (connected) to accessory equipment according the general description of use given by the applicant.

Preliminary testing as a first step, determines the worst-case phase line (neutral or phase) as well as the most critical amplitude by changing the operating mode. A complete frequency-sweep is performed with PK-Detector.

Final testing for power phases and critical frequencies (Margin to AV- or QP limit lower than 3dB) as a second step includes measurements either on discrete frequency components with receivers detector set to Quasi-Peak and Average per frequency component or a complete sweep with corresponding detector.

MEASUREMENT RESULTS

EUT Type and S/N or EUT set-up no.		EUT set-up 3			
EUT operating mode		EUT operating mode 2			
Diagram No.	Command or EUT operating mode or operating mode no.	Detector (Peak, CISPR AV, CISPR QP)	Power line (L1, L2, L3, N)	Additional (scan-) information (e.g. Pre-test Fast scan, Maxhold, Final measurement)	Result (passed / failed /final measurement . necessary)
1.1	EUT operating mode: Op. Mode 2: IDLE 1900	Peak, AV,QP	L1, N	The Diagram shows PK/AV detector measurements on L1 and N with max-hold mode. Final measurement QP and AV was carried out on at least one frequency (please see diagram)	passed

Remarks: The diagram 1.1 contains the maximum values from L 1 + N phase

EUT Type and S/N or EUT set-up no.		EUT set-up 3			
EUT operating mode		EUT operating mode 1			
Diagram No.	Command or EUT operating mode or operating mode no.	Detector (Peak, CISPR AV, CISPR QP)	Power line (L1, L2, L3, N)	Additional (scan-) information (e.g. Pre-test Fast scan, Maxhold, Final measurement)	Result (passed / failed /final measurement . necessary)
1.3	EUT operating mode: Op. Mode 1: IDLE 850	Peak, AV,QP	L1, N	The Diagram shows PK/AV detector measurements on L1 and N with max-hold mode. Final measurement QP and AV was carried out on at least one frequency (please see diagram)	passed

Remarks: The diagram 1.3 contains the maximum values from L1 + N phase

Margin to Limit for verdict: $M = L_T - R_R + C_{Loss}$

Abbreviations used:

- R_R : Receiver readings in dB μ V
- C_{Loss} : cable loss
- L_T : Limit in dB μ V

VERDICT

Summary of measurement results for conducted emissions on AC-Power lines: Passed

4.6. Radiated emissions, 30 MHz - 1 GHz, §15.109 class B, RSS132, RSS133, RSS-gen

TEST LOCATION AND EQUIPMENT (for reference numbers please see chapter 'List of test equipment')

test location	<input checked="" type="checkbox"/> CETECOM Essen (Chapter. 2.2.1)	<input type="checkbox"/> Please see Chapter. 2.2.2	<input type="checkbox"/> Please see Chapter. 2.2.3
test site	<input checked="" type="checkbox"/> 441 EMI SAR	<input type="checkbox"/> 487 SAR NSA	<input type="checkbox"/> 337 OATS
receiver	<input type="checkbox"/> 377 ESCS30	<input checked="" type="checkbox"/> 001 ESS	<input type="checkbox"/> 347 Radio.lab.
spectr. analys.	<input type="checkbox"/> 381 380 FSBS	<input type="checkbox"/> 120 FSEM	<input type="checkbox"/> 264 FSEK
antenna	<input checked="" type="checkbox"/> 048 EMCO3143	<input type="checkbox"/> 133 EMCO3115	<input type="checkbox"/> 302 BBHA9170
signaling	<input type="checkbox"/> 298 CMU	<input type="checkbox"/> 460 CMU	<input checked="" type="checkbox"/> 289 CBL 6141
power supply	<input type="checkbox"/> 456 EA 3013A	<input checked="" type="checkbox"/> 087 EA 3013A	<input type="checkbox"/> 392 MT8820A
otherwise	<input type="checkbox"/> 400 FTC40x15E	<input type="checkbox"/> 401 FTC40x15E	<input type="checkbox"/> 459 EA 2032-50
			<input type="checkbox"/> 268 EA- 3050
			<input type="checkbox"/> 494 AG6632A
			<input type="checkbox"/> 498 NGPE 40
			<input checked="" type="checkbox"/> 482 Filter Matrix

STANDARDS AND LIMITS: CFR 47, PART 15, SUBPART B, §15.109 (CLASS B), §15.209, ANSI C63.4

Frequency [MHz]	Radiated emission limits, Class B, 3 meters		Radiated emission limits, Class A, 10 meters	
	QUASI-Peak [microvolts/meter]	QUASI-Peak [dBµV/m]	QUASI-Peak [microvolts/meter]	QUASI-Peak [dBµV/m]
30-88	100	40	90	39,0
88-216	150	43,5	150	43,5
216-960	200	46,0	210	46,4
above 960	500	54,0	300	59,5

TEST CONDITION AND MEASUREMENT TEST SET-UP

link to test system (if used):	<input checked="" type="checkbox"/> air link	<input type="checkbox"/> cable connection	<input type="checkbox"/>
EUT-grounding	<input checked="" type="checkbox"/> none	<input type="checkbox"/> with power supply	<input type="checkbox"/> additional connection
Equipment set up	<input checked="" type="checkbox"/> table top 0.8m height		<input type="checkbox"/> floor standing
Climatic conditions	Temperature: (24°C)		Rel. humidity: (30)%
EMI-Receiver (Analyzer) Settings	Span/Range: 30 MHz to 1 GHz RBW/VBW: 120 kHz / (auto) Detector/ Mode: PEAK, TRACE max-hold mode, repetitive scan Quasi-Peak, for final measurement for critical measurements		

GENERAL MEASUREMENT PROCEDURES:

The measurement test set-up and test procedure are in accordance with the provisions described in ANSI 63.4: 2009

The *Equipment under Test* (EUT) set-up to defined operating mode and installed (connected) to accessory equipment according the general description of use given by the applicant.

MEASUREMENT METHOD (30 MHz < f < 1 GHz):

An EMI analyzer together with a broadband antenna was used in order to identify the emissions from the EUT by positioning the antenna close to the EUT surfaces.

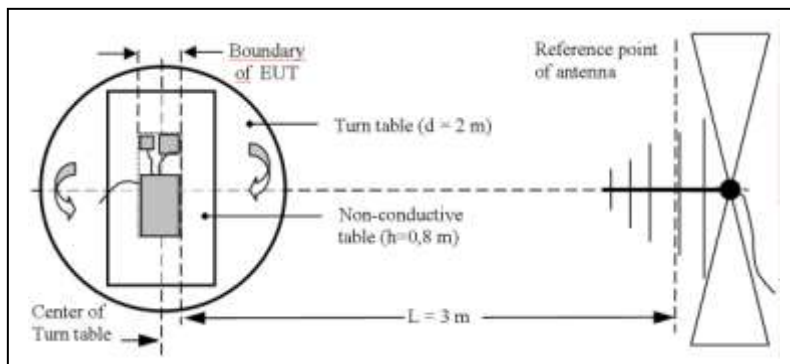

The interconnecting cables and equipment position were varied in order to maximize the emissions. Then most critical frequencies are recorded for further investigations. Based on the exploratory measurements, the most critical frequencies are re-measured by maintaining the EUT's operating mode, cable position, etc. The EUT was placed on a non-conductive support of 0.8 m height. By rotating the turntable angle in the range 0 to 360 degree, the EUT itself either over

3-orthogonal axis (not defined usage position) or 2-orthogonal axis (defined usage position) and the measurement antenna height from 1 meter to 4 meters, the maximized emissions are recorded. The measurements are performed for both polarizations of the measuring antenna: horizontal and vertical.

RESULTS

Set-up No.		1								
Operating Mode		2								
Diagram no.	Frequency	MaxPeak	Meas. Time	Bandwidth	Antenna height	Polarity	Turntable position	Corr. (dB)	Margin (dB)	Limit (dBµV/m)
	(MHz)	(dBµV/m)	(ms)	(kHz)	(cm)		(deg)	(C _F)	(M)	(L _T)
2.01	866.36	40.09	10	120	100-400	H/V	0..360°	--	--	46.0 QP)
	30..1000 MHz	< 42.5 (PK)	10	120	100-400	H/V	0..360°	--	--	Part 15.109B

Remark: *.) see also plots enclosed in separate annex A1

Set-up No.		1								
Operating Mode		1								
Diagram no.	Frequency	MaxPeak	Meas. Time	Bandwidth	Antenna height	Polarity	Turntable position	Corr. (dB)	Margin (dB)	Limit (dBµV/m)
	(MHz)	(dBµV/m)	(ms)	(kHz)	(cm)		(deg)	(C _F)	(M)	(L _T)
2.02	316.28	28.79	10	120	100-400	H/V	0..360°	--	--	46.0 (QP)
	30..1000 MHz	< 40.0 (PK)	10	120	100-400	H/V	0..360°	--	--	Part 15.109B

Remark: *.) see also plots enclosed in separate annex A1

Signals due to base stations BCCH Signals: GSM850 – Channel 182 – 880MHz

<p>Margin to Limit:</p> $M = L_T - R_R + C_F + D_F$ $= L_T - R_R + AF_{ANTENNA} + Cable_{LOSS} + D_F$ <p>Remark: positive margin means passed result</p>	<p>Abbreviations used:</p> <ul style="list-style-type: none"> • R_R : Receiver readings in dBµV/m • C_F: Transducer in dB = AF (antenna factor) + CL (cable loss) • D_F : distance correction factor (if different measurement distance used than specified in the standard)
---	--

VERDICT

Summary of measurement results for radiated emissions above 30 MHz and below 1 GHz : Passed

4.7. Radiated emissions, above 1GHz, §15.109 class B, RSS132, RSS133, RSS-gen

TEST LOCATION AND EQUIPMENT (for reference numbers please see chapter 'List of test equipment')

test site	<input type="checkbox"/> 441 EMI SAR	<input type="checkbox"/> 348 EMI cond.	<input checked="" type="checkbox"/> 443 EMI FAR	<input type="checkbox"/> 347 Radio.lab.	<input type="checkbox"/> 337 OATS	<input type="checkbox"/>
equipment	<input type="checkbox"/> 331 HC 4055	<input type="checkbox"/>	<input type="checkbox"/>	<input type="checkbox"/>	<input type="checkbox"/>	<input type="checkbox"/>
Spectr. analys.	<input type="checkbox"/> 138 139 FSBS	<input type="checkbox"/> 120 FSEM	<input type="checkbox"/> 264 FSEK	<input checked="" type="checkbox"/> 489 ESU	<input type="checkbox"/>	<input type="checkbox"/>
antenna meas	<input type="checkbox"/> 048 3143	<input type="checkbox"/> 289 CBL 6141	<input checked="" type="checkbox"/> 439 HL 562	<input checked="" type="checkbox"/> 549 HL452	<input type="checkbox"/> 302 BBHA9170	<input type="checkbox"/> 477 GPS
antenna meas	<input type="checkbox"/> 123 HUF-Z2	<input type="checkbox"/> 132 HUF-Z3	<input type="checkbox"/> 030 HFH-Z2	<input type="checkbox"/>	<input type="checkbox"/>	<input type="checkbox"/>
antenna subst	<input type="checkbox"/> 071 HUF-Z2	<input type="checkbox"/> 020 EMCO3115	<input type="checkbox"/> 063 LP 3146	<input type="checkbox"/> 303 BBHA9170	<input type="checkbox"/>	<input type="checkbox"/>
power meter	<input type="checkbox"/> 009 NRV	<input type="checkbox"/> 010 URV5-Z2	<input type="checkbox"/> 011 URV5-Z2	<input type="checkbox"/>	<input type="checkbox"/>	<input type="checkbox"/>
Signalgener.	<input type="checkbox"/> 008 SMG	<input type="checkbox"/> 140 SMHU	<input type="checkbox"/> 263 SMP04	<input type="checkbox"/>	<input type="checkbox"/>	<input type="checkbox"/>
power meter	<input type="checkbox"/> 262 NRV-S	<input type="checkbox"/> 266 NRV-Z31	<input type="checkbox"/> 265 NRV-Z33	<input type="checkbox"/> 261 NRV-Z55	<input type="checkbox"/> 356 NRV-Z1	<input type="checkbox"/>
DCpower	<input type="checkbox"/> 086 LNG50-10	<input checked="" type="checkbox"/> 087 EA3013	<input type="checkbox"/> 354 NGPE 40	<input type="checkbox"/> 349 car battery	<input type="checkbox"/> 350 Car battery	<input type="checkbox"/>
multimeter	<input type="checkbox"/> 341 Fluke 112	<input type="checkbox"/>	<input type="checkbox"/>	<input type="checkbox"/>	<input type="checkbox"/>	<input type="checkbox"/>
signaling	<input type="checkbox"/> 298 CMU	<input checked="" type="checkbox"/> 546 CMU	<input type="checkbox"/> 295 RACAL	<input type="checkbox"/> 392 MT8820A		

STANDARDS AND LIMITS: CFR 47, PART 15, SUBPART B, §15.109 (CLASS B), §15.209, ANSI C63.4

Frequency [MHz]	Radiated emission limits, 3 meters measurement distance			
	AV [microvolts/meter]	AV [dBµV/m]	Peak [microvolts/meter]	Peak [dBµV/m]
above 1GHz	500	54.0	5000	74.0

TEST CONDITION AND MEASUREMENT TEST SET-UP

link to test system (if used):	<input checked="" type="checkbox"/> air link	<input type="checkbox"/> cable connection	<input type="checkbox"/>
EUT-grounding	<input checked="" type="checkbox"/> none	<input type="checkbox"/> with power supply	<input type="checkbox"/> additional connection
Equipment set up	<input checked="" type="checkbox"/> table top 1.5m height		<input type="checkbox"/> floor standing
Climatic conditions	Temperature: (24°C)		Rel. humidity: (30)%
Spectrum-Analyzer settings	Span/Frequency range : 1..10 GHz +single frequencies determined in step 1 RBW/VBW: 1 MHz / 3 MHz Detector/ Mode: Peak, MAX-hold, repetitive scan for exploratory measurement PEAK/ AVERAGE, for final measurement for critical frequencies Antenna Polarisation Horizontal / Vertical		

GENERAL MEASUREMENT PROCEDURES:

The measurement test set-up and test procedure are in accordance with the provisions described in ANSI 63.4: 2009.

The *Equipment under Test* (EUT) was placed on a non-conductive positioning table of 0.8 or 1.5 meter height depending from the frequency range. The measuring distance was set to 3 meter for frequencies up to 18GHz and 1 meter above 18GHz.

The EUT was set-up to defined operating mode and installed (connected) to accessory equipment according the general description of use given by the applicant.

For the upper frequency measurement range, it was assumed that the highest frequency generated in the device is same as the highest operable TX-frequency in GSM1900 Mode (1909.8 MHz). Therefore the upper frequency limit was set to 10GHz for IDLE 1900 operating mode or 6GHz for IDLE 850.

1. Step exploratory measurement: see above description as in the frequency range lower 1GHz.

2. Step Final Measurement(1 GHz<f <18 GHz): On the Worst-Case EUT configuration, frequency components with a margin lower than 6 dB to the limits, will be re-measured by maintaining the EUT's operating mode, cable position, etc.. For find the worst-case emission, the turntable was changed in the range 0 to 360 degree and the EUT itself either over 3-orthogonal axis (not defined usage position) or 2-orthogonal axis (defined usage position). The measurements are performed for both polarizations of the measuring antenna: horizontal and vertical.

MEASUREMENT RESULTS:

Set-up No.		1								
Operating Mode		1								
Diagram no.	Frequency	MaxPeak	Meas. Time	Bandwidth	Antenna height	Polarity	Turntable position	Corr. (dB)	Margin (dB)	Limit (dBμV/m)
	(MHz)	(dBμV/m)	(ms)	(kHz)	(cm)		(deg)	(CF)	(M)	(LT)
2.03	2.504GHz	61.34 (PK)	10	1000	155.0	H/V	0..360°	--	12.66 (PK)	74.0 (PK)
	1867.6	42.81 (AV)	10	1000	155.0	H/V	0..360°	--	11.19 (AV)	54.0 (AV)

Remark: 1.) diagrams shows PK/AV detector measurements
 *.) see also plots enclosed in separate annex 1

Set-up No.		1								
Operating Mode		1								
Diagram no.	Frequency	MaxPeak	Meas. Time	Bandwidth	Antenna height	Polarity	Turntable position	Corr. (dB)	Margin (dB)	Limit (dBμV/m)
	(MHz)	(dBμV/m)	(ms)	(kHz)	(cm)		(deg)	(CF)	(M)	(LT)
2.04	3519.9	44.2 (PK)	100	1000	155.0	V	8.0	-0.7	29.8	74.0 (PK)
	3519.9	31.0 (AV)	100	1000	155.0	V	-10.0	-0.7	23.0	54.0 (AV)

Remark: 1.) diagrams shows PK/AV detector measurements
 *.) see also plots enclosed in separate annex 1

Set-up No.		1								
Operating Mode		2								
Diagram no.	Frequency	MaxPeak	Meas. time	Bandwidth	Antenna height	Polarity	Turntable position	Corr. (dB)	Margin (dB)	Limit (dBμV/m)
	(MHz)	(dBμV/m)	(ms)	(kHz)	(cm)		(deg)	(CF)	(M)	(LT)
2.05	1958.0 remark 2.)	50.27 (PK)	10	1000	155.0	H/V	0..360°	--	--	74 (PK) 54 (AV)
	1-2.8GHz	< 47.5 (PK)	10	1000	155.0	H/V	0..360°	--	>20 to PK	74.0 (PK)

Remark: 1.) diagrams shows PK/AV detector measurements
 *.) see also plots enclosed in separate annex 1
 2.) Signal due to base stations BCCH Signal: GSM1900, Channel 651 – 1958MHz

Set-up No.		1								
Operating Mode		2								
Diagram no.	Frequenc y (MHz)	MaxPeak (dBµV/m)	Meas. Time (ms)	Bandwidth (kHz)	Antenna height (cm)	Polarity	Turntable position (deg)	Corr. (dB) (CF)	Margin (dB) (M)	Limit (dBµV /m) (LT)
2.06	3795.30	43.4 (PK)	100.0	1000	155.0	V	331.0	--	30.6	74.0 (PK)
	3871.80	46.3 (PK)	100.0	1000	155.0	V	338.0	--	27.7	
	3915.90	46.3 (PK)	100.0	1000	155.0	H	316.0	--	27.7	
	3871.40	29.2 (AV)	100.0	1000	155.0	V	343.0	--	24.8	54.0 (AV)
	3915.90	33.2 (AV)	100.0	1000	155.0	H	310.0	--	20.8	

Remark: 1.) diagrams shows PK/AV detector measurements
 *.) see also plots enclosed in separate annex 1

<p>Margin to Limit:</p> $M = L_T - R_R + C_F + D_F$ $= L_T - R_R + AF_{ANTENNA} + Cable_{LOSS} + D_F$ <p>Remark: positive margin means passed result</p>	<p>Abbreviations used:</p> <ul style="list-style-type: none"> • R_R : Receiver readings in dBµV/m • CF: Transducer in dB = AF (antenna factor) + CL (cable loss) • D_F : distance correction factor (if different measurement distance used than specified in the standard) • L_T : Limit in dBµV/m
---	---

VERDICT

Summary of measurement results for radiated emissions above 1 GHz : Passed

5. Measurement uncertainties

The reported uncertainties are calculated based on the standard uncertainty multiplied with the appropriate coverage factor **k**, such that a confidence level of approximately 95% is achieved.

For uncertainty determination, each component used in the concrete measurement set-up was taken in account and it's contribution to the overall uncertainty according it's statistical distribution calculated.

Following table shows expectable uncertainties for each measurement type performed.

Measurement	Frequency range	Calculated uncertainty based on a confidence level of 95%	Remarks:
RF-Power Output conducted	9 kHz .. 20 GHz	1.0 dB	--
RF-Power Output radiated	30 MHz .. 4 GHz	3.17 dB	Substitution method
Conducted RF-emissions on antenna ports	9 kHz .. 20 GHz	1.0 dB	--
Radiated RF-emissions enclosure	150 kHz .. 30 MHz	5.0 dB	Magnetic field
	30 MHz .. 1 GHz	4.2 dB	E-Field
	1 GHz .. 18GHz	4.8 dB	E-Field
	1 GHz .. 20 GHz	3.17 dB	Substitution method
Occupied bandwidth	9 kHz .. 4 GHz	0.1272 ppm (Delta Marker method)	Frequency error
		1 dB	Power
Emission bandwidth	9 kHz .. 4 GHz	0.1272 ppm (Delta Marker method)	Frequency error
		1 dB	Power
Frequency stability	9 kHz .. 20 GHz	0.0636 ppm	--
Conducted emissions on AC-mains port (U _{CISPR})	9 kHz .. 150 kHz	4.0 dB	--
	150 kHz .. 30 MHz	3.6 dB	

Table : measurement uncertainties, valid for conducted/radiated measurements

6. Instruments and Ancillary

6.1. Used equipment "CTC"

The "Ref.-No" in the left column of the following tables allows the clear identification of the laboratory equipment.

6.1.1. Test software and firmware of equipment

Ref.-No.	Equipment	Type	Serial-No.	Version of Firmware or Software during the test
001	emi test receiver	ESS	825132/017	Firm.= 1.21 , OTP=2.0, GRA=2.0
012	signal generator (EMS-cond.)	SMY 01	839069/027	Firm.= V 2.02
013	power meter (EMS cond.)	NRVD	839111/003	Firm.= V 1.51
017	Communication Tester	CMD 60 M	844365/014	Firmware = V 3.52 .22.01.99, DECT Firmware D2.87
053	audio analyzer	UPA3	860612/022	Firm. V 4.3
119	RT harmonics analyser/dig. flickermeter	B10	G60547	Firm.= V 3.1DHG
140	signal generator	SMHU	831314/006	Firm.= 3.21
261	thermal power sensor	NRV-Z55	825083/0008	EPROM-Datum 02.12.04, SE EE 1 B
262	power meter	NRV-S	825770/0010	Firm.= 2.6
263	signal generator	SMP 04	826190/0007	Firm.=3.21
264	spectrum analyzer	FSEK 30	826939/005	Bios=2.1, Analyzer= 3.20
295	Racal Digital Radio Test Set	6103	1572	UNIT Firmware= 4.04, SW-Main=4.04, SW-BBP=1.04,
298	Univ. Radio Communication Tester	CMU 200	832221/091	R&S Test Firmware =3.53 /3.54 (current Testsoftw. f.
323	Communication Tester	CMD 055	825878/0034	Firm.= 3.52 .22.01.99
331	climatic test chamber -40/+80 Grad	HC 4055	43146	TSI 1.53
335	System-CTC-EMS-Conducted	System EMS Conducted	-	EMS-K1 Immunity Test-Software 1.20SR10
340	Univ. Communication Tester	CMD 55	849709/037	Firm.= 3.52 .22.01.99
355	power meter	URV 5	891310/027	Firm.= 1.31
365	10V Insertion Unit 50 Ohm	URV5-Z2	100880	Eprom Data = 31.03.08
366	Ultra Compact Simulator	UCS 500 M4	V0531100594	Firm. UCS 500=001925/3.06a02, rc=ISMIEC 4.10
371	Bluetooth Tester	CBT32	100153	CBT V4.6.1 + SW-Option K55
377	emi test receiver	ESCS 30	100160	Firm.= 2.30, OTP= 02.01, GRA= 02.36
378	broadband RF field monitor	RadiSense III	03D00013SNO-08	Firm.= V.03D13
383	signal generator	SME 03	842 828 /034	Firm.= 4.61
389	digital multimeter	Keithley 2000	0583926	Firm. = A13 (Mainboard) A02 (Display)
392	Radio Communication Tester	MT8820A	6K00000788	Firm.= 4.50 #005, IPL=4.01#001,OS=4.02#001,
441	System CTC-SAR-EMI Cable Loss	System EMI field (SAR)	-	EMC 32 Version 8.10.10
442	System CTC-SAR-EMS	System EMS field (SAR)	-	EMS-K1 Immunity-Software 1.20SR10
443	System CTC-FAR-EMI-Spuri	System CTC-FAR-EMI-	-	Spuri 7.2.5
444	System CTC FAR-EMS	System EMS-Field (FAR)	-	EMS-K1 Immunity-Software 1.20SR10
460	Univ. Radio Communication Tester	CMU 200	108901	R&S Test Firmware Base=5.14/Messsoftware=
489	emi test receiver	ESU40	1000-30	Firmware=4.43 SP3, Bios=V5.1-16-3,
491	ESD Simulator dito	ESD dito	dito307022	V 2.30
524	Voltage Drop Simulator	VDS 200	0196-16	Software Nr: 000037 Version V4.20a01
526	Burst Generator	EFT 200 A	0496-06	Software Nr. 000034 Version V2.32
527	Micro Pulse Generator	MPG 200 B	0496-05	Software-Nr. 000030 Version V2.43
528	Load Dump Simulator	LD 200B	0496-06	Software-Nr. 000031 Version V2.35a01
547	Univ. Radio Kommunikation Tester	CMU 200	835390/014	R&S Test Firmware Base=V5.1403 (current Testsoftw.
584	Spectrum Analyzer	FSU 8	100248	2.82_SP3
594	Kommunikation Tester	CMW500	101757	Firmware and Applications 1.0.15.23
597	Univ. Radio Communication Tester	CMU 200	100347	R&S Test Firmware Base=5.01/Messsoftware=
598	Spectrum Analyser	FSEM 30	831259/013	Firmware Bios 3.3 , Analyzer 3.3

6.1.2. Single instruments and test systems

Ref.-No.	Equipment	Type	Serial-No.	Manufacturer	Interval of calibration	Remark	Cal due
001	emi test receiver	ESS	825132/017	Rohde & Schwarz	12 M	-	31.03.2011
005	AC - LISN (50 Ohm/50µH, test site 1)	ESH2-Z5	861741/005	Rohde & Schwarz	24 M	-	31.03.2012
007	DC - LISN (50 Ohm/5µH)	ESH3-Z6	892563/002	Rohde & Schwarz	24 M	-	31.03.2012
009	power meter (EMS-radiated)	NRV	863056/017	Rohde & Schwarz	12 M	-	31.03.2011
011	insertion unit (EMS-radiated)	URV5-Z2	864169/004	Rohde & Schwarz	24 M	-	31.03.2011
012	signal generator (EMS-cond.)	SMY 01	839069/027	Rohde & Schwarz	36/12 M	-	31.03.2011
013	power meter (EMS cond.)	NRVD	839111/003	Rohde & Schwarz	24 M	-	31.03.2011
014	insertion unit (EMS cond.)	URV5-Z2	838519/029	Rohde & Schwarz	24 M	-	31.03.2011
015	insertion unit (EMS cond.)	URV5-Z4	838570/024	Rohde & Schwarz	24 M	-	31.03.2011
016	line impedance simulating network	Op. 24-D	B6366	Spitzenberger+Spies	36 M	-	31.03.2013
017	Communication Tester	CMD 60 M	844365/014	Rohde & Schwarz	12 M	-	31.03.2011
020	horn antenna 18 GHz (Subst 1)	3115	9107-3699	EMCO	36/12 M	-	31.03.2013
021	loop antenna (H-Field)	6502	9206-2770	EMCO	36 M	-	31.03.2013
022	audio measurement amplifier	2636C	1537643	Brüel & Kjaer	12 M	-	31.03.2011
030	loop antenna (H-field)	HFH-Z2	879604/026	Rohde & Schwarz	36 M	-	31.03.2012
031	absorbing clamp	MDS-21	863325/015	Rohde & Schwarz	24 M	-	31.03.2012
033	RF-current probe. (100kHz-30MHz)	ESH2-Z1	879581/18	Rohde & Schwarz	24 M	-	31.03.2011
049	current clamp (injection)	F-120-2	48	FCC	12 M	-	31.03.2011
050	3-ph coupling-decoupling-netw. (Burst)	CDN 300	176	Schaffner	24 M	-	31.03.2012
051	VHF-current probe 20-300 MHz	ESV-Z1	872421	Rohde & Schwarz	36 M	-	31.03.2012
052	notch filter DECT	WRCB 1887,82/1889,55SS	12	Wainwright Industries	pre-m	-	30.05.2011
053	audio analyzer	UPA3	860612/022	Rohde & Schwarz	36 M	-	31.03.2011
057	relay-switch-unit (EMS system)	RSU	494440/002	Rohde & Schwarz	-	1a	30.05.2011
058	capacitive clamp (Burst)	IP 4	99	Hafely	-	4	
060	power amplifier (DC-2kHz)	PAS 5000	B6363	Spitzenberger+Spies	-	3	
066	notch filter (WCDMA; FDD1)	WRCT 1900/2200-5/40-	5	Wainwright GmbH	12 M	-	30.05.2011
067	coupling decoupling-network	CDN801-M2/M3	272	Lüthi	12 M	-	31.03.2011
068	coupling decoupling-network	CDN 801-M5	95226	Lüthi	12 M	-	31.03.2011
069	EM - clamp	EM101	9535159	Lüthi	36 M	-	31.03.2013
072	coupling decoupling-network	CDN801-M2/M3	276	Lüthi	12 M	-	31.03.2011
083	AC - power supply, 0-10 A	EAC/MT 27010	910502096	EURO TEST	pre-m	2	
084	AC - power supply, 0-5 A	ELABO-8-34214	-	ELABO	pre-m	2	
085	AC - power supply, 0-10 A	R250	-	Schunterm.&Benningh.	pre-m	2	
086	DC - power supply, 0 -10 A	LNG 50-10	-	Heinzinger Electronic	pre-m	2	
087	DC - power supply, 0 -5 A	EA-3013 S	-	Elektro Automatik	pre-m	2	
090	Helmholtz coil: 2x10 coils in series	-	-	RWTÜV	pre-m	4	
091	USB-LWL-Converter	OLS-1	007/2006	Ing. Büro Scheiba	-	4	
094	artificial head (No.1)	4905	1566990	Brüel & Kjaer	pre-m	2	
099	passive voltage probe	ESH2-Z3	299.7810.52	Rohde & Schwarz	36 M	-	31.03.2012
100	passive voltage probe	Probe TK 9416	without	Schwarzbeck	36 M	-	31.03.2012
110	USB-LWL-Converter	OLS-1	-	Extreme USB	-	4	
119	RT harmonics analyser/dig. flickermeter	B10	G60547	BOCONSULT	36 M	-	31.03.2013
121	notch filter GSM 1900	WRCB 1879.5/1880,5EE	15	Wainwright GmbH	12 M	-	30.05.2011
122	notch filter GSM 1800	WRCB 1747/1748	12	Wainwright GmbH	12 M	-	30.05.2011
131	RF-Current Probe	F-52	19	FCC	12 M	-	31.03.2011
134	horn antenna 18 GHz (Subst 2)	3115	9005-3414	EMCO	12 M	-	31.03.2011
136	adjustable dipole antenna (Dipole 1)	3121C-DB4	9105-0697	EMCO	12 M	-	31.03.2012
140	signal generator	SMHU	831314/006	Rohde & Schwarz	24 M	-	31.03.2012
248	attenuator	SMA 6dB 2W	-	Radiall	pre-m	2	
249	attenuator	SMA 10dB 10W	-	Radiall	pre-m	2	
252	attenuator	N 6dB 12W	-	Radiall	pre-m	2	
254	high pass GSM1800/1900/DECT	5HC 2600/12750-1,5KK	23042	Trilithic	12 M	-	30.05.2011
256	attenuator	SMA 3dB 2W	-	Radiall	pre-m	2	
257	hybrid	4031C	04491	Narda	pre-m	2	
260	hybrid coupler	4032C	11342	Narda	pre-m	2	
261	thermal power sensor	NRV-Z55	825083/0008	Rohde & Schwarz	24/12 M	-	31.03.2012
262	power meter	NRV-S	825770/0010	Rohde & Schwarz	24 M	-	31.03.2012
263	signal generator	SMP 04	826190/0007	Rohde & Schwarz	36 M	-	31.03.2013
264	spectrum analyzer	FSEK 30	826939/005	Rohde & Schwarz	12 M	-	31.03.2011
265	peak power sensor	NRV-Z33, Model 04	840414/009	Rohde & Schwarz	24 M	-	31.03.2012
266	peak power sensor	NRV-Z31, Model 04	843383/016	Rohde & Schwarz	24 M	-	31.03.2012
268	AC/DC power supply	EA 3050-A	9823636	-	pre-m	2	
270	termination	1418 N	BB6935	Weinschel	pre-m	2	
271	termination	1418 N	BE6384	Weinschel	pre-m	2	
272	attenuator (20 dB) 50 W	Model 47	BF6239	Weinschel	pre-m	2	
273	attenuator, (10 dB) 100 W	Model 48	BF9229	Weinschel	pre-m	2	
274	attenuator (10 dB) 50 W	Model 47 (10 dB) 50 W	BG0321	Weinschel	pre-m	2	
275	DC-Block	Model 7003 (N)	C5129	Weinschel	pre-m	2	
276	DC-Block	Model 7006 (SMA)	C7061	Weinschel	pre-m	2	
279	power divider	1515 (SMA)	LH855	Weinschel	pre-m	2	
284	coupling decoupling network	CDN 801-M1	1661	Lüthi	12 M	-	31.03.2011
285	coupling decoupling network	CDN 801-S1	1642	Lüthi	12 M	-	31.03.2011
287	pre-amplifier 25MHz - 4GHz	AMF-2D-100M4G-35-10P	379418	Miteq	12 M	-	30.05.2011
290	notch filter GSM 900	WRCA 901.9/903,1SS	3RR	Wainwright GmbH	12 M	-	30.05.2011
291	high pass filter GSM 850/900	WHJ 2200-4EE	14	Wainwright GmbH	12 M	-	30.05.2011
296	audio measurement amplifier	2636C	R=316568/004	Brüel & Kjaer	18 M	-	31.03.2011
298	Univ. Radio Communication Tester	CMU 200	832221/091	Rohde & Schwarz	12 M	-	31.03.2011
299	audio microphone	134	-	Brüel & Kjaer	pre-m	2	
300	AC LISN (50 Ohm/50µH, 1-phase)	ESH3-Z5	892 239/020	Rohde & Schwarz	12 M	-	31.03.2011

Ref.-No.	Equipment	Type	Serial-No.	Manufacturer	Interval of calibration	Remark	Cal due
301	attenuator (20 dB) 50W, 18GHz	47-20-33	AW0272	Lucas Weinschel	pre-m	2	
302	horn antenna 40 GHz (Meas 1)	BBHA9170	155	Schwarzbeck	36 M	-	31.03.2011
303	horn antenna 40 GHz (Subst 1)	BBHA9170	156	Schwarzbeck	36 M	-	31.03.2011
304	fix dipole antenna 1,6 GHz	EMCO 3125-307	9907-1001	ETS	24/12 M	-	31.03.2011
305	fix dipole antenna 1,8-2,0 GHz	EMCO 3125-306	9907-1001	ETS	24/12 M	-	31.03.2011
306	fix dipole antenna 2,45 GHz	EMCO 3125-308	9907-1001	ETS	24/12 M	-	31.03.2011
307	fix dipole antenna 3 GHz	EMCO 3125-309	9907-1001	ETS	24/12 M	-	31.03.2011
317	1000 Hz calibrator 94 dB SPL	4230 94dB	1542286	Brüel & Kjaer	12 M	-	31.03.2011
323	Communication Tester	CMD 055	825878/0034	Rohde & Schwarz	12 M	-	31.03.2011
331	climatic test chamber -40/+80 Grad	HC 4055	43146	Heraeus Vötsch	24 M	-	30.11.2012
340	Univ. Communication Tester	CMD 55	849709/037	Rohde & Schwarz	24 M	-	31.03.2012
341	digital multimeter	Fluke 112	81650455	Fluke	24 M	-	31.03.2012
342	digital multimeter	Voltcraft M-4660A	IB 255466	Voltcraft	24 M	-	31.03.2011
344	adaptor 150/50 Ohm	150/50	-	Krohne	12 M	-	31.03.2011
345	adaptor 150/50 Ohm	150/50	-	Krohne	12 M	-	31.03.2011
347	laboratory site	radio lab.	-	-	-	3	
348	laboratory site	EMI conducted	-	-	-	3	
349	car battery 12 V	car battery 12 V	without	-	-	3	
350	car battery 12 V	car battery 12 V	without	-	-	3	
354	DC - power supply 40A	NGPE 40/40	448	Rohde & Schwarz	pre-m	-	
355	power meter	URV 5	891310/027	Rohde & Schwarz	12 M	-	31.03.2011
356	power sensor	NRV-Z1	882322/014	Rohde & Schwarz	24 M	-	31.03.2011
357	power sensor	NRV-Z1	861761/002	Rohde & Schwarz	24 M	-	31.03.2011
358	Power Amplifier 10 kHz-220MHz	AR75A220M1	15860	Amplifier Research	12 M	1b	30.04.2010
365	10V Insertion Unit 50 Ohm	URV5-Z2	100880	Rohde & Schwarz	24 M	-	31.03.2012
366	Ultra Compact Simulator	UCS 500 M4	V0531100594	EM-Test	12 M	-	01.04.2011
367	audio measurement amplifier	2636	316832/001	Brüel & Kjaer	12 M	-	31.03.2011
369	insertion unit (SAR-EMS, Ch. A)	URV5-Z2	100301	Rohde & Schwarz	24 M	-	31.03.2011
370	insertion unit (SAR-EMS, Ch. B)	URV5-Z2	100302	Rohde & Schwarz	24 M	-	31.03.2011
371	Bluetooth Tester	CBT32	100153	R&S	12 M	-	31.03.2011
373	V-Network 5µH/50 Ohm	ESH3-Z6	100535	Rohde & Schwarz	12 M	-	31.03.2011
374	power amplifier 0,8-3 GHz	60S1G3	306528	Amplifier Research	-	1a	30.05.2011
375	directional coupler	DC7144M1	306498	Amplifier Research	-	1a	30.05.2011
376	horn antenna 6 GHz	BBHA9120 E	BBHA 9120 E 179	Schwarzbeck	12 M	-	01.04.2011
377	emi test receiver	ESCS 30	100160	Rohde & Schwarz	12 M	-	31.03.2011
378	broadband RF field monitor	RadiSense III	03D00013SNO-08	DARE B.V.	12 M	-	31.03.2011
383	signal generator	SME 03	842 828 /034	Rohde & Schwarz	36 M	-	31.03.2013
386	coupling decoupling network	CDN USB/p	19397	Schaffner	12 M	-	31.03.2011
387	coupling decoupling network	CDN L-801 M2	2051	Lüthi	12 M	-	31.03.2011
388	coupling decoupling network	CDN L-801 T2	1929	Lüthi	12 M	-	31.03.2011
389	digital multimeter	Keithley 2000	0583926	Keithley	24 M	-	31.03.2011
390	Industry Acoustic System	MO 2000 Set	2127100123	Sennheiser	-	4	
392	Radio Communication Tester	MT8820A	6K00000788	Anritsu	12 M	-	31.03.2011
394	power amplifier 80-1000 MHz	BLWA 0810-250/200	045610	Bonn-Elektronik	-	1a	30.05.2011
399	Sound Calibrator	Sound Calibrator 4231	2665101	Brüel & Kjaer	12 M	-	31.03.2011
400	ferrite tube (>15 dB, EN 55022)	FTC 40 X 15 E	5559	Lüthi	36 M	-	31.03.2012
401	ferrite tube (>15 dB, EN 55022)	FTC 40 X 15 E	5560	Lüthi	36 M	-	31.03.2012
431	Model 7405	Near-Field Probe Set	9305-2457	EMCO	-	4	
439	UltraLog-Antenna	HL 562	100248	Rohde + Schwarz	12 M	-	30.04.2011
440	CDN for Databable	CDN-UTP	CDN-UTP 029	EMC Partner AG,	24 M	-	31.03.2012
441	System CTC-SAR-EMI Cable Loss	System EMI field (SAR)	-	ETS	12 M	5	31.08.2011
442	System CTC-SAR-EMS	System EMS field (SAR)	-	ETS-	12 M	5	30.04.2011
443	System CTC-FAR-EMI-Spuri	System CTC-FAR-EMI-	-	ETS-Lindgren/Cetecom	12 M	5	30.06.2011
444	System CTC FAR-EMS	System EMS-Field (FAR)	-	ETS Lindgren/Cetecom	12 M	5	30.05.2011
448	notch filter WCDMA FDD II	WRCT 1850.0/2170.0-	5	Wainwright Instruments	12 M	1c	30.05.2011
449	notch filter WCDMA FDD V	WRCT 824.0/894.0-5/40-	1	Wainwright Instruments	12 M	1c	30.05.2011
454	Oscilloscope	HM 205-3	9210 P 29661	Hameg	-	4	
455	Oscilloscope	HP 54602B	US 350 336 45	Hawlett Packard	-	4	
456	DC-Power supply 0-5A	EA 3013 S	207810	Elektro Automatik	pre-m	2	
459	DC -power supply 0-5 A , 0-32 V	EA-PS 2032-50	910722	Elektro Automatik	pre-m	2	
460	Univ. Radio Communication Tester	CMU 200	108901	Rohde & Schwarz	12 M	-	31.03.2011
462	AF-Generator	MX-2020	-	Conrad	-	4	
463	Universal source	HP3245A	2831A03472	Agilent	-	4	
466	digital multimeter	Fluke 112	89210157	Fluke USA	24 M	-	31.03.2012
467	digital multimeter	Fluke 112	89680306	Fluke USA	24 M	-	31.03.2012
468	digital multimeter	Fluke 112	90090455	Fluke USA	24 M	-	31.03.2012
477	ReRadiating GPS-System	AS-47	-	Automotive Cons. Fink	-	3	
480	power meter (Fula)	NRVS	838392/031	Rohde & Schwarz	24 M	-	31.03.2011
482	filtermatrix	FilterMatrix SAR 1	-	CETECOM (Brl)	-	1d	
484	pre-amplifier 2,5 - 18 GHz	AMF-5D-02501800-25-	1244554	Miteq	12 M	-	01.06.2011
487	System CTC NSA-Verification SAR-EMI	System EMI field (SAR)	-	ETS	12 M	-	30.09.2011
489	emi test receiver	ESU40	1000-30	Rohde & Schwarz	12 M	-	31.03.2011
491	ESD Simulator dito	ESD dito	dito307022	EM-Test	24 M	-	31.03.2011
498	Power Supply	NGPE 40/40	402	Rohde & Schwarz	-	2	
500	industry Acoustic System	MO 2000 Set	100048	Sennheiser	-	4	
502	band reject filter	WRCG 1709/1786-	SN 9	Wainwright	-	2	
503	band reject filter	WRCG 824/849-814/859-	SN 5	Wainwright	-	2	
517	relais swite matrix	HF Relais Box Keithley	SE 04	Keithley	-	2	
523	Digitalmultimeter	L4411A	MY46000154	Agilent	24 M	-	31.03.2011
524	Voltage Drop Simulator	VDS 200	0196-16	EM Test	24 M	-	31.03.2011
525	Koppelnetzwerk	CNA 200	1196-01	EM Test	24 M	-	31.03.2011
526	Burst Generator	EFT 200 A	0496-06	EM Test	24 M	-	31.03.2011
527	Micro Pulse Generator	MPG 200 B	0496-05	EM Test	24 M	-	31.03.2011
528	Load Dump Simulator	LD 200B	0496-06	EM Test	24 M	-	31.03.2011
533	Impedance Stabilization Network	ISN T200A	25706	Teseq	12 M	-	31.03.2011

Ref.-No.	Equipment	Type	Serial-No.	Manufacturer	Interval of calibration	Remark	Cal due
534	Impedance Stabilization Network	ISN T400A	Teseq	12 M	-	31	
535	Impedance Stabilization Network	ISN T800	26321	Teseq	12 M	-	31.03.2011
536	Impedance Stabilization Network	ISN ST08	25867	Teseq	12 M	-	31.03.2011
541	Impedance Stabilization Network	ISN T8-Cat6	26373	Teseq Berlin	12 M	-	31.03.2011
547	Univ. Radio Kommunikation Tester	CMU 200	835390/014	Rohde & Schwarz	12 M	-	31.03.2011
548	Digital-Barometer	GBP 2300	without	Greisinger GmbH	36/12 M	-	31.03.2012
549	Log.Per-Antenna	HL025	1000060	Rohde & Schwarz	36/12 M	-	31.03.2012
552	high pass filter 2.8-18GHz	WHKX 2.8/18G-10SS	4	Wainwright	12 M	-	30.06.2011
558	System CTC FAR S-VSWR	System CTC FAR S-	-	CTC	24 M	-	31.08.2011
574	Biconilog Hybrid Antenna	BTA-L	980026L	Frankonia	36/12 M	-	30.03.2013
584	Spectrum Analyzer	FSU 8	100248	Rohde & Schwarz	12 M	-	31.03.2012
592	CDN-HDMI	CDN-HDMI	A3029004	Frankonia / Dr.Hubert	12 M	-	31.03.2011
594	Kommunikation Tester	CMW500	101757	Rohde & Schwarz	24 M	-	31.03.2012
595	Analog Adder	TS8910	-	Rohde & Schwarz	pre-m	-	
598	Spectrum Analyser	FSEM 30	831259/013	Rohde & Schwarz	12 M	-	13.01.2011

6.1.3. Legend

Note / remarks		Calibrated during system calibration:
	1a	System CTC-SAR-EMS (Ref.-No. 442)
	1b	System-CTC-EMS-Conducted (Ref.-No. 335)
	1c	System CTC-FAR-EMI-spurious emission (Ref.-No . 443)
	1d	System CTC-SAR-EMI (Ref.-No . 441)
	1e	System CTC-OATS (EMI radiated) (Ref.-No. 337)
	1 f	System CTC-CTIA-OTA (Ref.-No . 420)
	1 g	System CTC-FAR-EMS (Ref.-No . 444)
	2	Calibration or equipment check immediately before measurement
	3	Regulatory maintained equipment for functional check or support purpose,
	4	Ancillary equipment without calibration e.g. mechanical equipment or monitoring equipment
	5	Test System

Interval of calibration	12 M	12 month
	24 M	24 month
	36 M	36 month
	24/12 M	Calibration every 24 months, between this every 12 months internal validation
	36/12 M	Calibration every 36 months, between this every 12 months internal validation
	Pre-m	Check before starting the measurement
	-	Without calibration

Annex 1: Diagrams to
TEST REPORT
 No.: 2-20795542c/11

According to:
FCC Regulations
 FCC Part 15B
 &
IC Regulations
 RSS-Gen, Issue 2
 RSS-132, Issue 2
 RSS-133, Issue 5

for

Cinterion Wireless Modules GmbH

Quad-Band GSM/GPRS Module BGS2-W
 FCC-ID: QIPBGS2
 IC: 7830A-BGS2







Laboratory Accreditation and Listings			
 Deutsche Akkreditierungsstelle D-PL-12047-01-01	 FEDERAL COMMUNICATIONS COMMISSION U.S.A. MRA US-EU 0003	 Industry Canada Reg. No.: 3462D-1 3462D-2	 Reg. No.: R-2665, R-2666 C-2914, T-1967 G-301
 LAB CODE 20011130-00		 AUTHORIZED RF LABORATORY	
accredited according to DIN EN ISO/IEC 17025			
<p align="center"> CETECOM GmbH Laboratory Radio Communications & Electromagnetic Compatibility Im Teelbruch 116 • 45219 Essen • Germany Registered in Essen, Germany, Reg. No.: HRB Essen 8984 Tel.: + 49 (0) 20 54 / 95 19-954 • Fax: + 49 (0) 20 54 / 95 19-964 E-mail: info@cetecom.com • Internet: www.cetecom.com </p>			

Table of contents

1. ANNEX 1: DIAGRAMS	3
1.1. Conducted emissions on AC-mains	3
1.2. Spurious emissions conducted – IDLE 850 Mode (RX) accord. FCC15.111 requirement.....	7
1.3. Spurious emissions conducted – IDLE 850 Mode (RX) accord. Canada requirement	9
1.4. Spurious emissions conducted – IDLE 1900 Mode (RX) accord. Canada requirement	11
1.5. Radiated field strength – GSM850 RX-Mode	13
1.6. Radiated field strength – GSM1900 RX-Mode	19

1. Annex 1: Diagrams

1.1. Conducted emissions on AC-mains

Diagram No. 1.1

Common Information

Test Description:	Conducted Voltage Measurement Class B
Testspecification:	FCC 15.107, class B
Technical Data:	Please see next page for detailed information
Diagram:	Shows the peak values as a sum of measured ports (N+L1) in maxhold mode
Operator name:	MEL
Report.- Nr.	2-20795542a/11
EUT:	BG52-W + AC/DC Adapter DSB45+Handset Votronic + DSB45 + RS232+(Notebook)
Manufacturer:	Cinterion
Operating mode:	GSM 1900 IDLE (Channel RX=651)
Measured on line:	Mains AC L1 and N
Power during test:	110 V AC 60 Hz
Comment 1:	DSB45: DC-9V powered over AC/DC Adapter, GSM Module=4.5V internal voltage

01_Class B_Voltage_PK_QPAV_N_L1

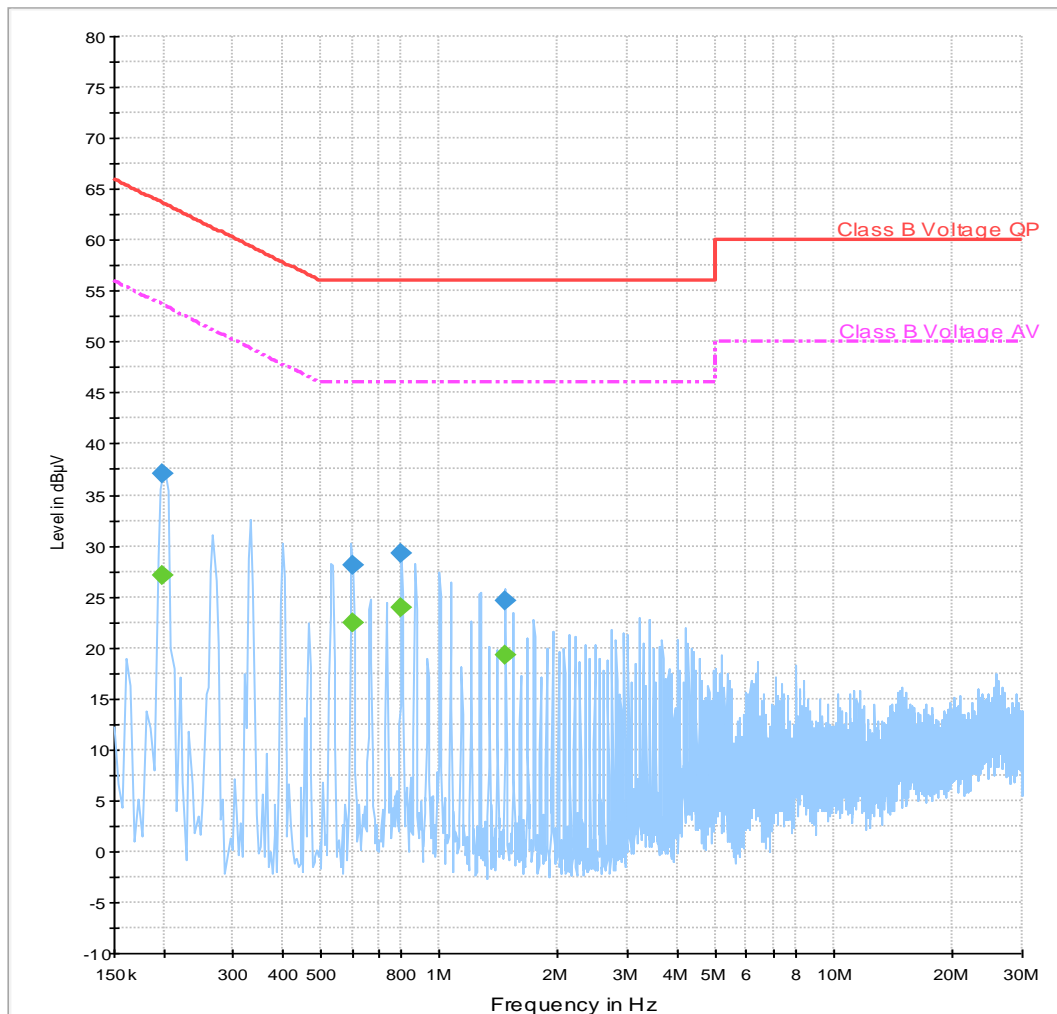

Final Result 1

Frequency (MHz)	QuasiPeak (dBµV)	Meas. Time (ms)	Bandwidth (kHz)	PE	Line	Corr. (dB)	Margin (dB)	Limit (dBµV)
0.198281	37.0	15000.0	9.000	GND	N	0.0	26.7	63.7
0.601719	28.2	15000.0	9.000	GND	N	0.0	27.8	56.0
0.800938	29.2	15000.0	9.000	GND	N	0.0	26.8	56.0
1.467812	24.5	15000.0	9.000	GND	N	0.1	31.5	56.0

Final Result 2

Frequency (MHz)	CAverage (dBµV)	Meas. Time (ms)	Bandwidth (kHz)	PE	Line	Corr. (dB)	Margin (dB)	Limit (dBµV)
0.198281	27.1	15000.0	9.000	GND	N	0.0	26.6	53.7
0.601719	22.5	15000.0	9.000	GND	N	0.0	23.5	46.0
0.800938	23.9	15000.0	9.000	GND	N	0.0	22.1	46.0
1.467812	19.3	15000.0	9.000	GND	N	0.1	26.7	46.0

Technical Data of Measurements with R&S EMC32 V8.40.0**Hardware Setup: EMI conducted\ESH2-Z5 - [EMI conducted]**

Subrange 1

Frequency Range: 150 kHz - 30 MHz

Receiver: Receiver [ESCS 30]
@ GPIB0 (ADR 19), SN Ref.-Nr. 377, FW 2.30 02.01 02.36

Signal Path: ESH2-Z5 Kabeldämpfung
Correction Table: Conducted Voltage ESH2-Z5 cable loss

LISN: ESH2-Z5
Correction Table (Line 0): 4-Line-LISN ESH2-Z5 Line N
Correction Table (Line 1): 4-Line-LISN ESH2-Z5 Line L1
Correction Table (Line 2): 4-Line-LISN ESH2-Z5 Line L2
Correction Table (Line 3): 4-Line-LISN ESH2-Z5 Line L3

EMI Auto Test Template: 01_Class B_Voltage_PK_QPAV_N_L1

Hardware Setup: ESH2-Z5
Measurement Type: 4 Line LISN
Frequency Range: 150 kHz - 30 MHz
Graphics Level Range: -10 dBµV - 80 dBµV

Preview Measurements:
Scan Test Template:

02_Class B_pre_PK_fast

Subrange	Step Size	Detectors	IF BW	Meas. Time	Preamp
150 kHz - 30 MHz	3.906 kHz	PK+	9 kHz	0,00005 s	0 dB

Receiver: [ESCS 30]

Data Reduction:

Limit Line #1: Class B Voltage QP
Limit Line #2: Class B Voltage AV
Peak Search: 6 dB , Maximum Results: 10
Subrange Maxima: 50 Subranges , Maxima per Subrange: 2
Acceptance Offset: -13 dB
Maximum Number of Results: 30
After Data Reduction: Interactive data reduction

Frequency Zoom:

Zoom Scan Template: 08_Class B_maxZoom_PK100mS

Subrange	Step Size	Detectors	IF BW	Meas. Time	Preamp
150 kHz - 30 MHz	5 kHz	PK+	9 kHz	0,1 s	0 dB

Receiver: [ESCS 30]

Final Measurements:

Template for Single Meas.: 07_Class B_fin AV QP

Subrange	Step Size	Detectors	IF BW	Meas. Time	Preamp
150 kHz - 30 MHz	4.5 kHz	QPK; CAV	9 kHz	15 s	0 dB

Receiver: [ESCS 30]

Report Settings:

Report Template: Ctc_Standard_class_B
Create Electronic Report: RTF PDF
Document Name: EMI Report

Actions:

Test stop
Notify: "End of Test"

Diagram No. 1.3

Common Information

Test Description:	Conducted Voltage Measurement Class B
Testspecification:	FCC 15.107 class B
Technical Data:	Please see next page for detailed information
Diagram:	Shows the peak values as a sum of measured ports (N+L1) in maxhold mode
Operator name:	Lor
Operating mode:	IDLE 850 Mode (Channel RX=182)
Measured on line:	Mains AC L1 and N
Power during test:	110 V AC 60 Hz
Remark:	DSB45: DC-9V powered over AC/DC Adapter, GSM Module=4.5V internal voltage

EUT Information

EUT Name:	BGS2-W+AC/DC Adapter+DSB45+Handset Votronic+RS232+USB+(Notebook)
Manufacturer:	Cinerion
Serial Number:	IMEI #8449

01_Class B_Voltage_PK_QPAV_N_L1

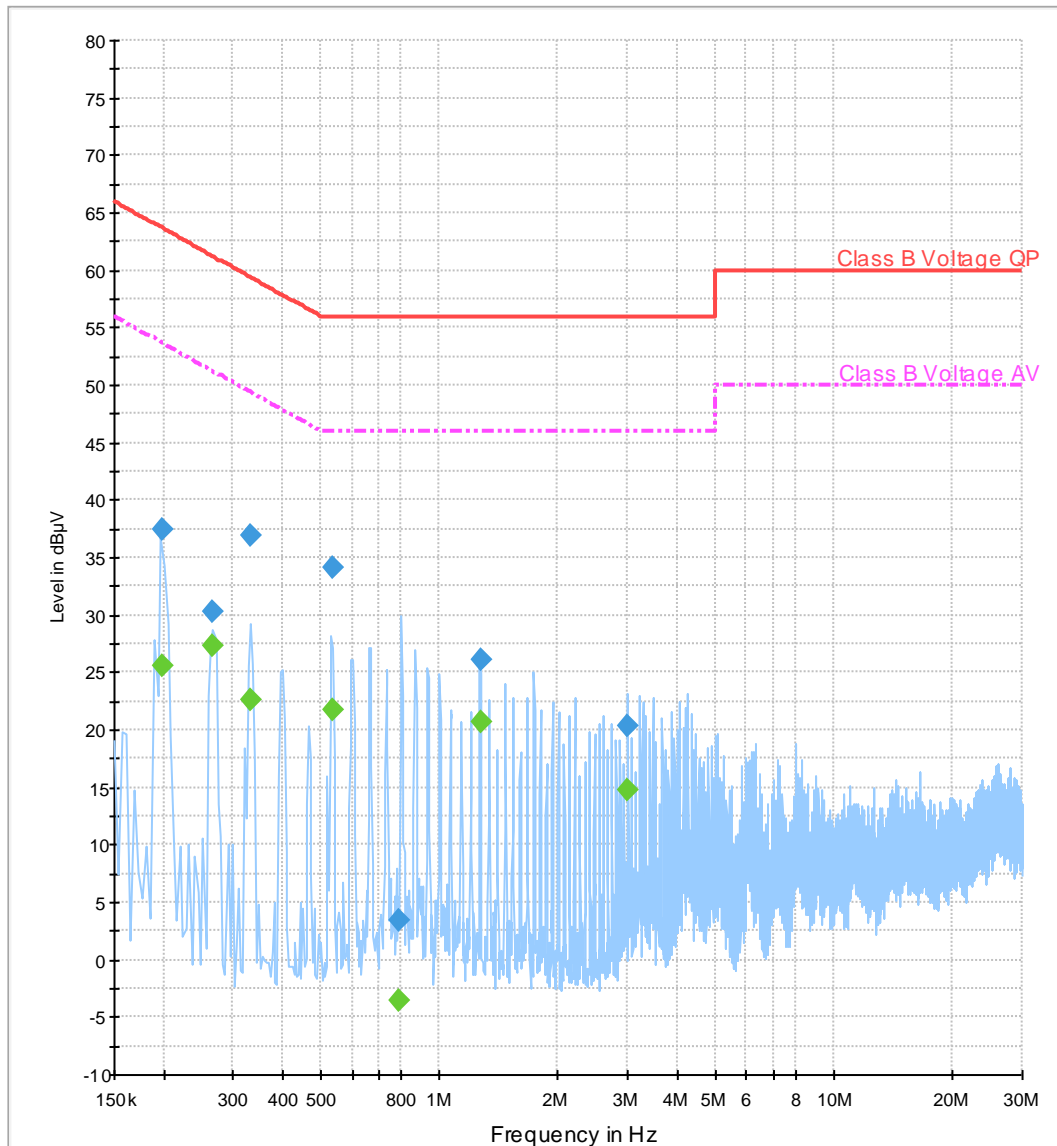

Final Result 1

Frequency (MHz)	QuasiPeak (dBµV)	Meas. Time (ms)	Bandwidth (kHz)	PE	Line	Corr. (dB)	Margin (dB)	Limit (dBµV)
0.199375	37.4	15000.0	9.000	GND	L1	0.0	26.2	63.6
0.265781	30.2	15000.0	9.000	GND	N	0.1	31.0	61.2
0.331094	36.9	15000.0	9.000	GND	N	0.0	22.5	59.4
0.534219	34.1	15000.0	9.000	GND	N	0.0	21.9	56.0
0.785938	3.5	15000.0	9.000	GND	N	0.1	52.5	56.0
1.269688	26.0	15000.0	9.000	GND	N	0.1	30.0	56.0
3.002969	20.3	15000.0	9.000	GND	N	0.1	35.7	56.0

Final Result 2

Frequency (MHz)	CAverage (dBµV)	Meas. Time (ms)	Bandwidth (kHz)	PE	Line	Corr. (dB)	Margin (dB)	Limit (dBµV)
0.199375	25.6	15000.0	9.000	GND	L1	0.0	28.0	53.6
0.265781	27.3	15000.0	9.000	GND	N	0.1	23.9	51.2
0.331094	22.7	15000.0	9.000	GND	N	0.0	26.7	49.4
0.534219	21.7	15000.0	9.000	GND	N	0.0	24.3	46.0
0.785938	-3.6	15000.0	9.000	GND	N	0.1	49.6	46.0
1.269688	20.8	15000.0	9.000	GND	N	0.1	25.2	46.0
3.002969	14.7	15000.0	9.000	GND	N	0.1	31.3	46.0

Technical Data of Measurements with R&S EMC32 V8.40.0**Hardware Setup: EMI conducted\ESH2-Z5 - [EMI conducted]**

Subrange 1

Frequency Range: 150 kHz - 30 MHz

Receiver: Receiver [ESCS 30]
@ GPIB0 (ADR 19), SN Ref.-Nr. 377, FW 2.30 02.01 02.36

Signal Path: ESH2-Z5 Kabeldämpfung
Correction Table: Conducted Voltage ESH2-Z5 cable loss

LISN: ESH2-Z5
Correction Table (Line 0): 4-Line-LISN ESH2-Z5 Line N
Correction Table (Line 1): 4-Line-LISN ESH2-Z5 Line L1
Correction Table (Line 2): 4-Line-LISN ESH2-Z5 Line L2
Correction Table (Line 3): 4-Line-LISN ESH2-Z5 Line L3

EMI Auto Test Template: 01_Class B_Voltage_PK_QPAV_N_L1

Hardware Setup: ESH2-Z5
Measurement Type: 4 Line LISN
Frequency Range: 150 kHz - 30 MHz
Graphics Level Range: -10 dBµV - 80 dBµV

Preview Measurements:

Scan Test Template: 02_Class B_pre_PK_fast

Subrange	Step Size	Detectors	IF BW	Meas. Time	Preamp
150 kHz - 30 MHz	3.906 kHz	PK+	9 kHz	0,00005 s	0 dB

Receiver: [ESCS 30]

Data Reduction:

Limit Line #1: Class B Voltage QP
Limit Line #2: Class B Voltage AV
Peak Search: 6 dB, Maximum Results: 10
Subrange Maxima: 50 Subranges, Maxima per Subrange: 2
Acceptance Offset: -13 dB
Maximum Number of Results: 30
After Data Reduction: Interactive data reduction

Frequency Zoom:

Zoom Scan Template: 08_Class B_maxZoom_PK100mS

Subrange	Step Size	Detectors	IF BW	Meas. Time	Preamp
150 kHz - 30 MHz	5 kHz	PK+	9 kHz	0,1 s	0 dB

Receiver: [ESCS 30]

Final Measurements:

Template for Single Meas.: 07_Class B_fin_AV_QP

Subrange	Step Size	Detectors	IF BW	Meas. Time	Preamp
150 kHz - 30 MHz	4.5 kHz	QPK; CAV	9 kHz	15 s	0 dB

Receiver: [ESCS 30]

Report Settings:

Report Template: Ctc_Standard_class_B
Create Electronic Report: RTF PDF
Document Name: EMI Report

1.2. Spurious emissions conducted – IDLE 850 Mode (RX) accord. FCC15.111 requirement

RX-Channel 182

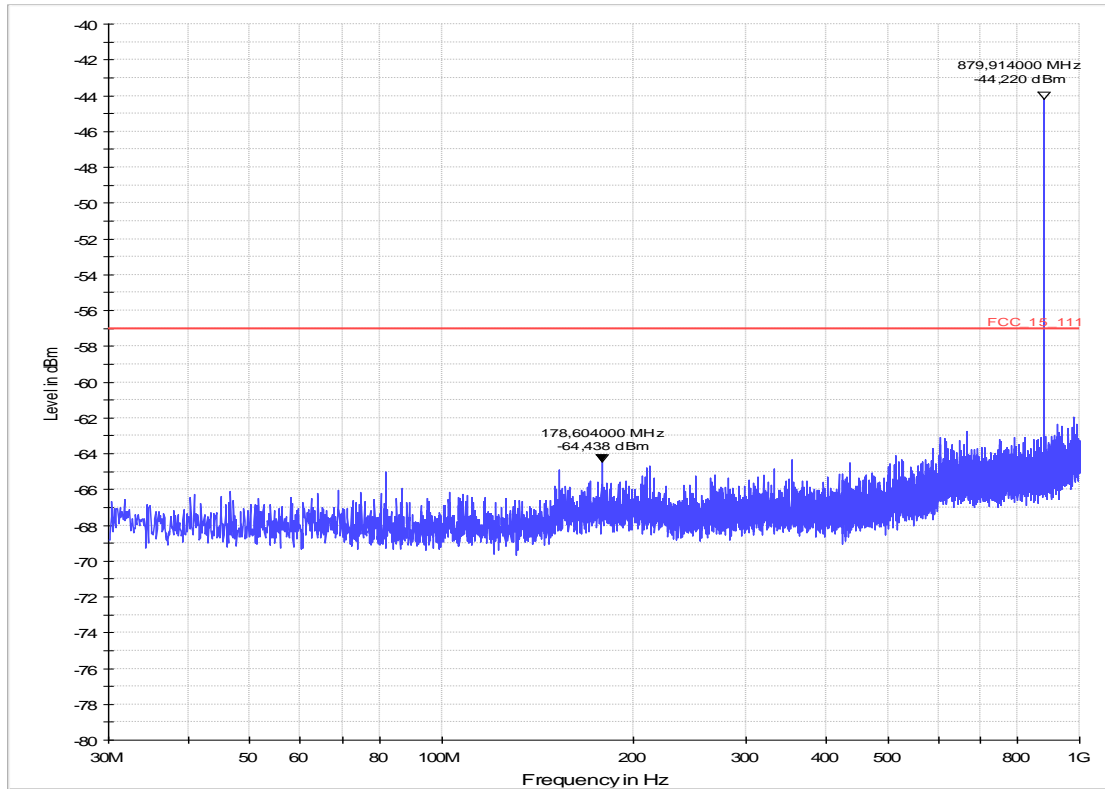

Sweep 14.21

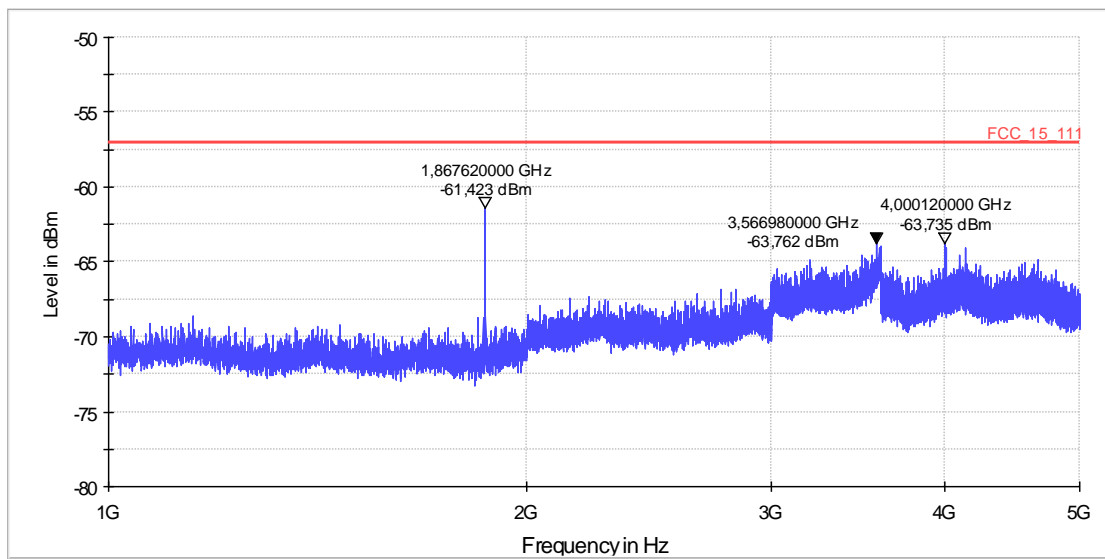

Sweep 14.22 Pre-Test

Final measurements to 14.22 – Discrete frequencies

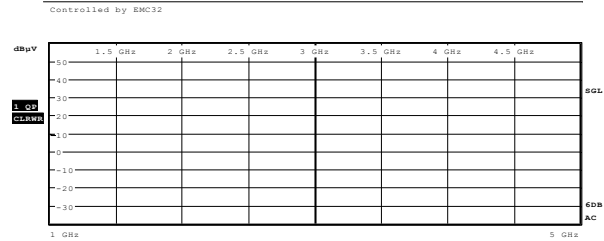
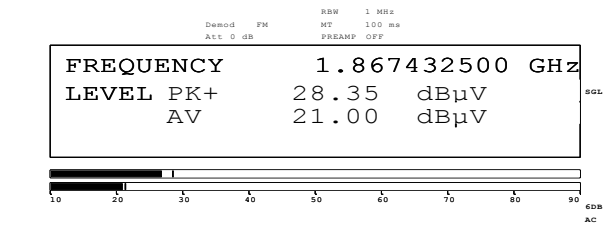

Date: 11.FEB.2011 14:34:32

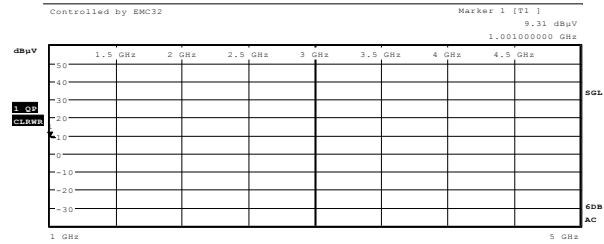
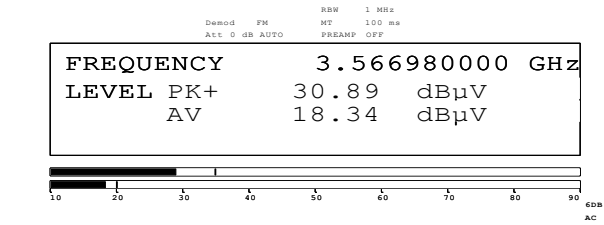

Date: 11.FEB.2011 14:37:16

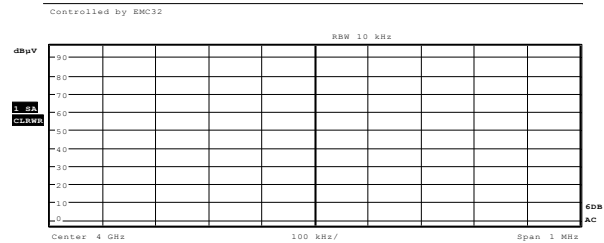
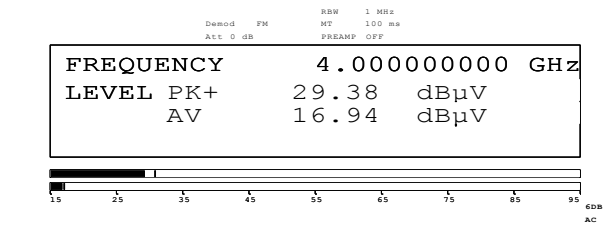

Date: 11.FEB.2011 14:33:06

1.3. Spurious emissions conducted – IDLE 850 Mode (RX) accord. Canada requirement

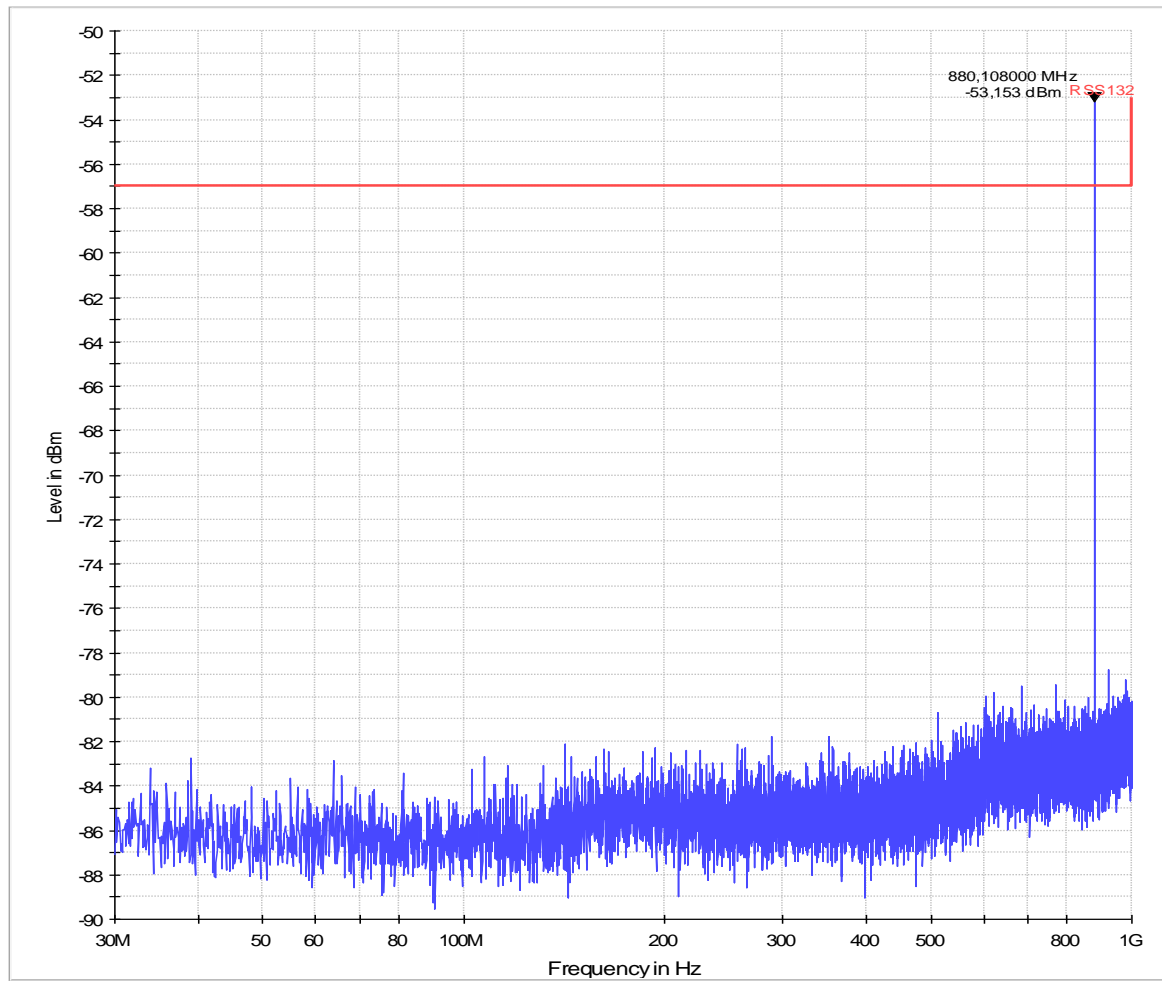

Sweep 14.17

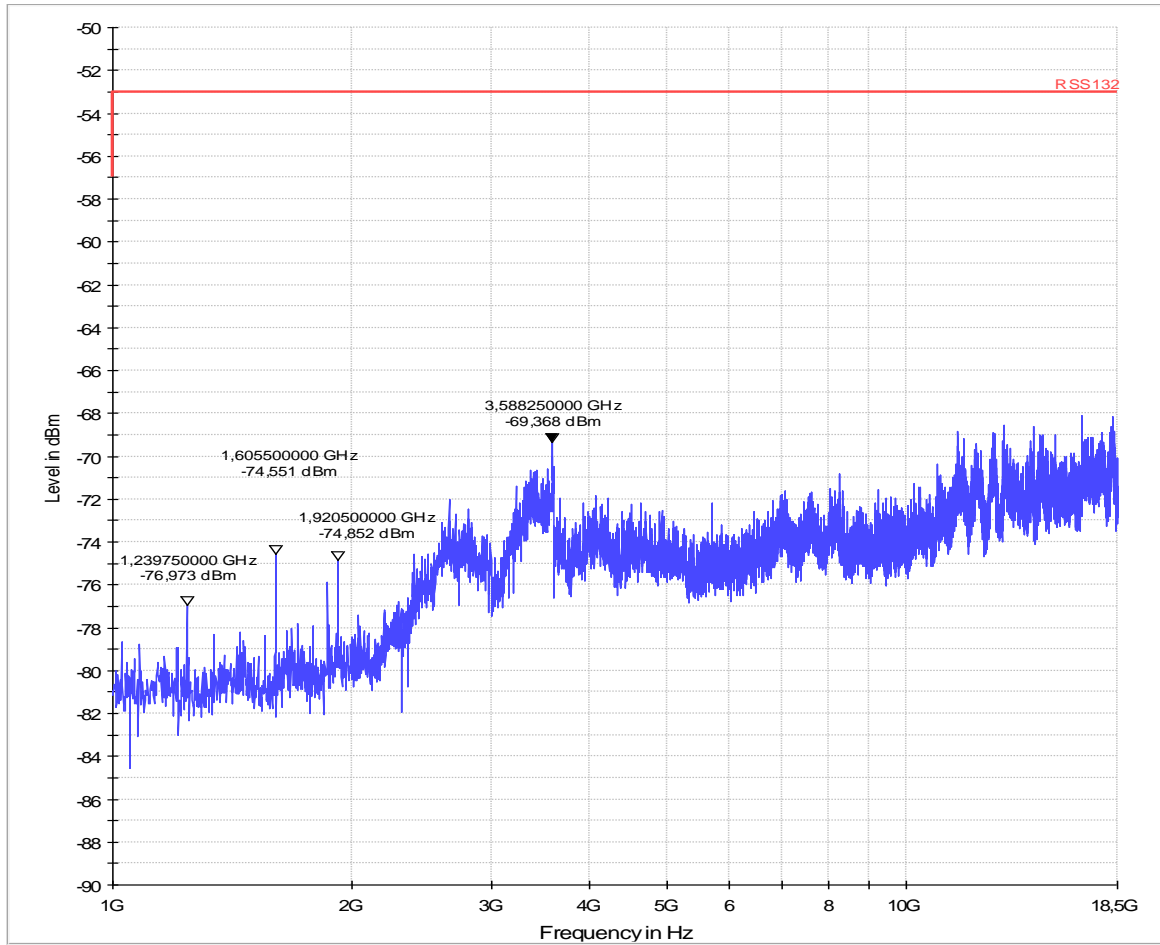

Sweep 14.18

1.4. Spurious emissions conducted – IDLE 1900 Mode (RX) accord. Canada requirement

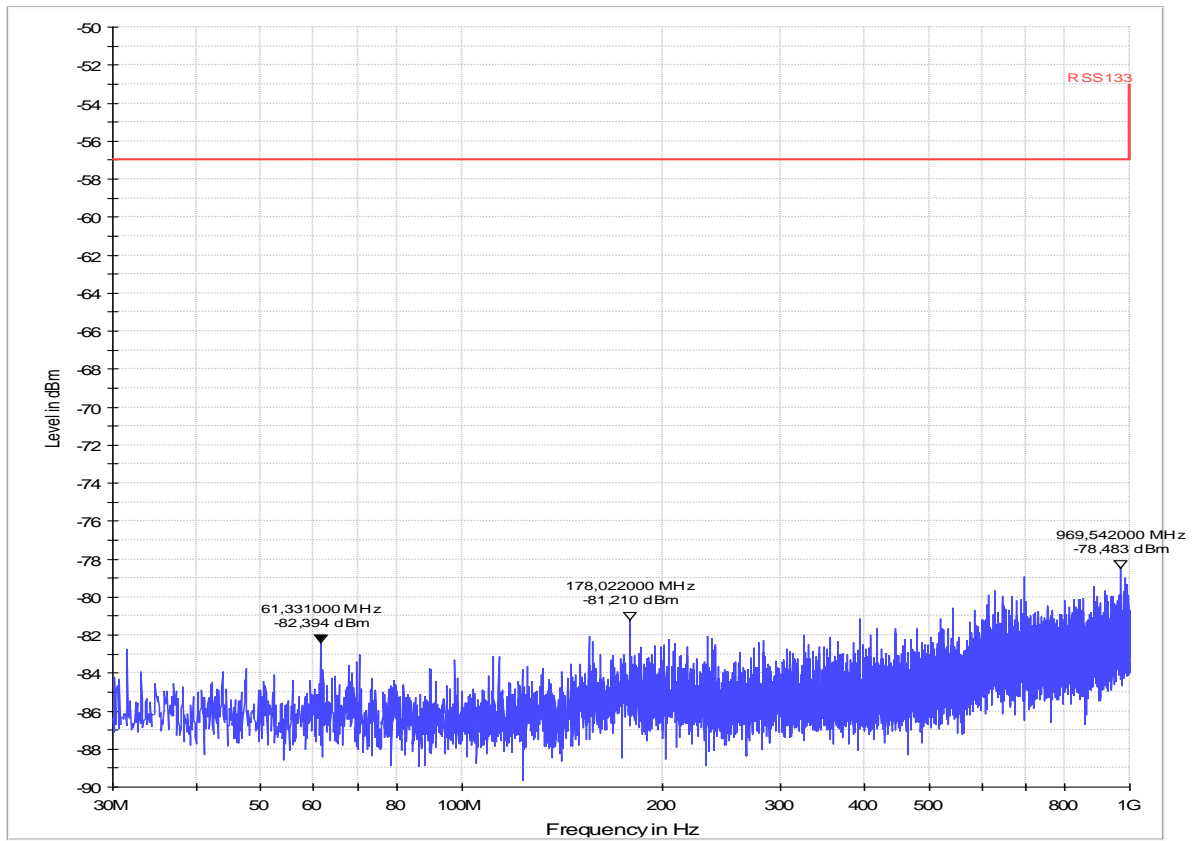

Sweep 14.19

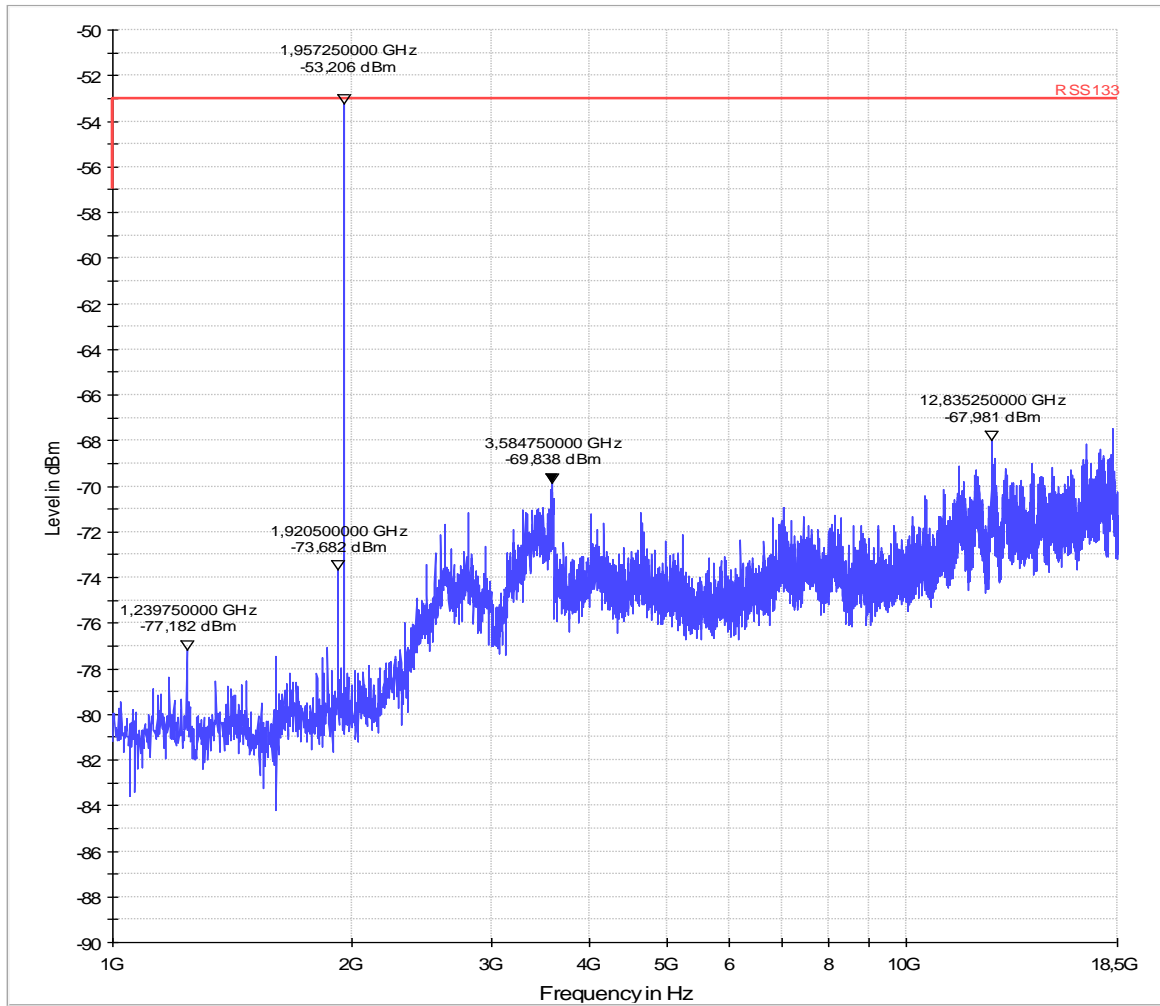

Sweep 14.20

1.5. Radiated field strength – GSM850 RX-Mode

Diagram No. 2.02

Common Information

Test description:	Electric Field strength Measurement
Test site and distance:	Semi Anechoic Room (SAR) with 3 m measurement distance
Measured sides of EUT:	front, right, rear, left
Rec. antenna (pre-scan):	height 1.00 m and 1.82 m, horizontal and vertical polarisation
Rec. antenna (final):	height between 1 m to 4 m, polarisation according to pre-scan results
Turntable step:	90° during pre-scan, continuously turning during final measurement
Used filter:	Low-pass 1200 MHz
Test specification.:	FCC 15.109 class B

Operator:	Tas
Operating conditions:	Idle Mode GSM850 (BCCH 182)
EUT:	BGS2-W (CINTERION); HW B2 (IMEI 00440108048446800)
Add. Equipment:	USB cable, Handset Votronic (v1.1), DSB45 box, RS 232 cable
Voltage	4,5 V DC

FCC15.109_hor+vert

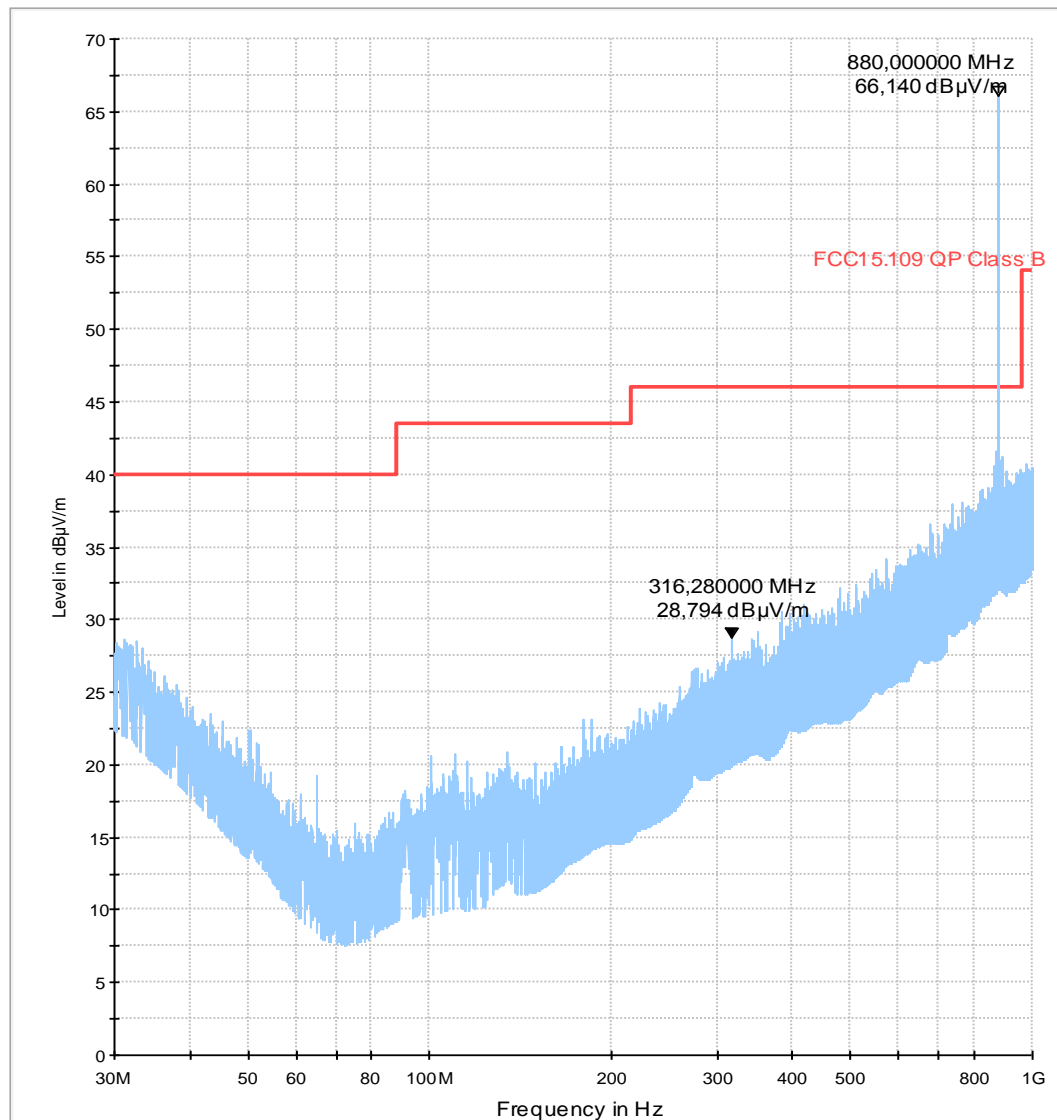



EMI Auto Test Template: FCC15.109_hor+vert

Hardware Setup: HW11_FCC_ESCS30_TP1200
 Measurement Type: Open-Area-Test-Site
 Frequency Range: 30 MHz - 1 GHz
 Graphics Level Range: 0 dBµV/m - 60 dBµV/m

Preview Measurements:
 Antenna height: 100 - 182 cm , Step Size = 82 cm , Positioning Speed = 8
 Polarization: H + V
 Turntable position: 0 - 270 deg , Step Size = 90 deg , Positioning Speed = 8
 Scan Test Template: EMI Scan 01_fast_FCC 15_209 B

Subrange	Step Size	Detectors	IF BW	Meas. Time	Preamp
30 MHz - 1 GHz	40 kHz	PK+	120 kHz	0,00005 s	0 dB

Receiver: [ESS]

Data Reduction:
 Limit Line #1: FCC15.109 QP Class B
 Peak Search: 6 dB , Maximum Results: 10
 Subrange Maxima: 25 Subranges , Maxima per Subrange: 1
 Acceptance Offset: -6 dB
 Maximum Number of Results: 10
 After Data Reduction: Interactive data reduction

Frequency Zoom:
 Zoom Scan Template: EMI Scan 02_20ms_zoom_FCC 15_209 B

Subrange	Step Size	Detectors	IF BW	Meas. Time	Preamp
30 MHz - 1 GHz	10 kHz	PK+	120 kHz	0,02 s	0 dB

Receiver: [ESS]

Adjustment:
 Antenna height: Adjustment with full Range , Measuring Speed = 8
 Turntable position: Adjustment with full Range , Measuring Speed = 4
 Template for Single Meas.: EMI Scan 02_20ms_FCC 15_209 B

Subrange	Step Size	Detectors	IF BW	Meas. Time	Preamp
30 MHz - 1 GHz	100 kHz	PK+	120 kHz	0,02 s	0 dB

Receiver: [ESS]

Final Measurements:
 Template for Single Meas.: EMI Scan 03_1s_FCC 15_209 B

Subrange	Step Size	Detectors	IF BW	Meas. Time	Preamp
30 MHz - 1 GHz	100 kHz	QPK	120 kHz	1 s	0 dB

Receiver: [ESS]

Report Settings:
 Report Template: FCC15_209_vert_hor
 Create Electronic Report: RTF PDF
 Document Name: EMI Report

Actions:
 Data Reduction: Before
 Notify: Sound (WAV file) 'tada.wav'
 Final Measurements: After
 Notify: Sound (WAV file) 'tada.wav'

Diagram No. 2.03

Date: 10.02.2011 Page 1 of 3

Test description: Electric Field strength Measurement
 Test site and distance: Semi Anechoic Room (SAR) with 3m measurement distance
 Distance correction: height of receiving antenna h= 1m, horizontal & vertical
 Technical Data: Please see page 2 for detailed data of measurement setup
 Test specification: FCC15 109 B

Operator: Tas
 Operating conditions: Idle Mode GSM 850 (BCCH 182)
 Measured sides of EUT: front, right, rear, left
 EUT: BGS2-W (CINTERION); HW B2 (IMEI 00440108048446800)
 Add. equipment: USB cable, Handset Votronic (v1.1), DSB45 box, RS 232 cable
 Voltage: 4,5 V DC

012_FCC_15_109B_1_to_6_GHz_Hom_BBHA9120_hor_ver

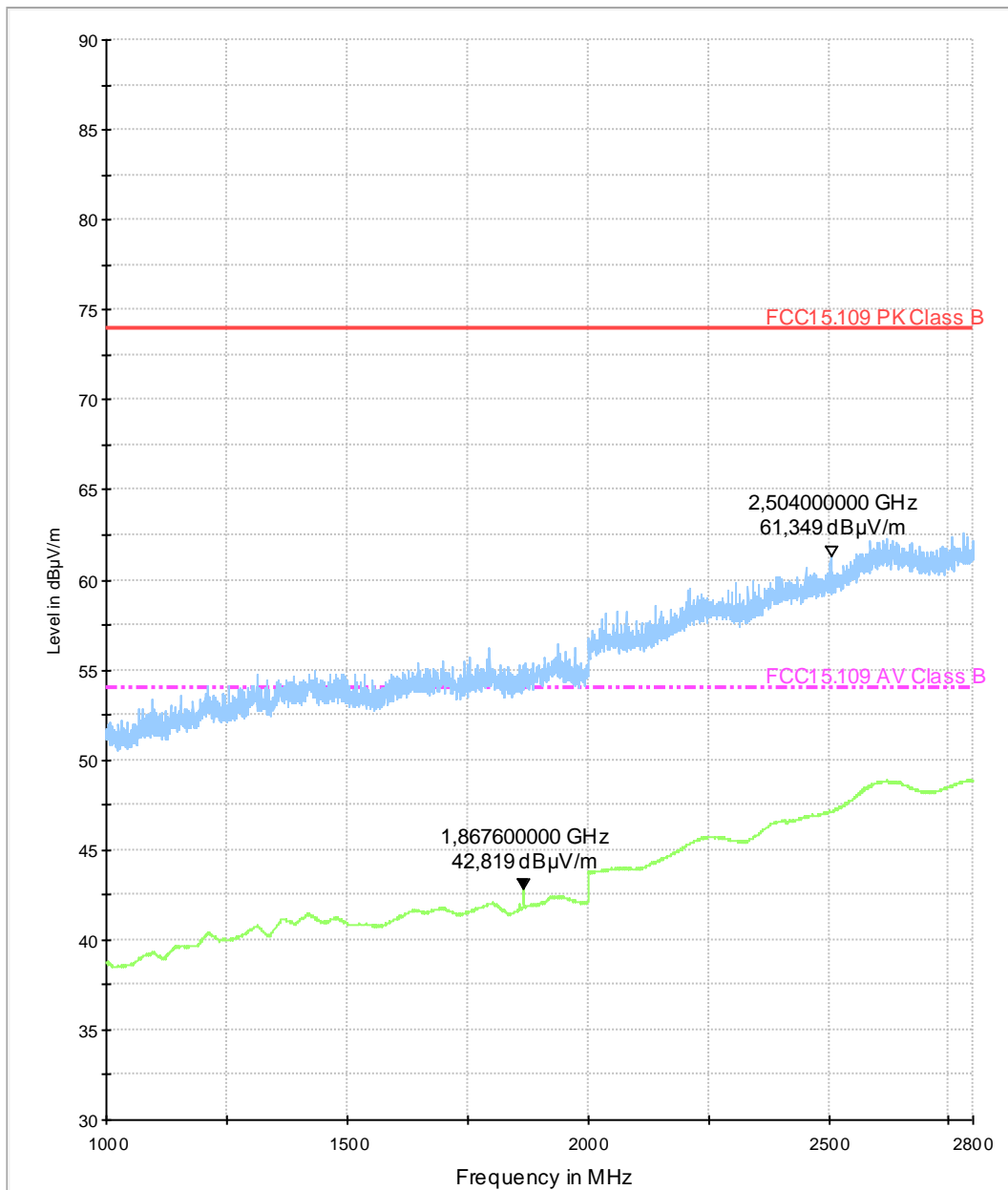

Technical Data of measurement with EMC32 V8.40.2

Hardware Setup: EMI radiated\HW25_ESU40_HP_HornSchwarzbeck_6_GHz - [EMI radiated]

Subrange 1

Frequency Range: 1 GHz - 6 GHz

Receiver: Receiver 2 [ESU 40]
@ GPIB0 (ADR 4), SN 100030/040, FW 4.43

Signal Path: HP wainright -WHK1000-12ST

Antenna: Horn Schwarzbeck bis 6GHz
SN 179
Correction Table (vertical): Schwarzbeck Horn bis 6GHz
Correction Table (horizontal): Schwarzbeck Horn bis 6GHz
Correction Table (vertical): 500_SAR EMI-Kabelpfad Hornantenne bis 18 GHz_mit HP
Correction Table (horizontal): 500_SAR EMI-Kabelpfad Hornantenne bis 18 GHz_mit HP

Antenna Tower: Mast_2 PSN [Generic Tripod]
@ GPIB0 (ADR 21), SN ?

Turntable: Inn-Co Turntable [Inn-Co Turntable]
@ GPIB0 (ADR 7)

EMI Auto Test Template: 012_FCC_15_109B_1_to_6_GHz_Horn_BBHA9120_hor_ver

Hardware Setup: HW25_ESU40_HP_HornSchwarzbeck_6_GHz

Measurement Type: Open-Area-Test-Site

Frequency Range: 1 GHz - 2,8 GHz

Graphics Level Range: 30 dB μ V/m - 90 dB μ V/m

Preview Measurements:

Antenna height: 100 - 100 cm , Step Size = 0 cm , Positioning Speed = 8

Polarization: H + V

Turntable position: 35 - 380 deg , Step Size = 15 deg , Positioning Speed = 8

Scan Test Template: 04_ESU_BBHA_9120_E_6GHz_pre_15109B

Subrange	Step Size	Detectors	IF BW	Meas. Time	Preamp
1 GHz - 6 GHz	400 kHz	PK+; AVG	1 MHz	0,01 s	0 dB

Receiver: [ESU 40]

Data Reduction:

Limit Line #1: FCC15.109 PK Class B

Limit Line #2: FCC15.109 AV Class B

Peak Search: 6 dB , Maximum Results: 10

Subrange Maxima: 25 Subranges , Maxima per Subrange: 1

Acceptance Offset: -6 dB

Maximum Number of Results: 35

After Data Reduction: Interactive data reduction

Frequency Zoom:

Zoom Scan Template: 05_ESU_BBHA_9120_E_6GHz_zoom_15109B

Adjustment:

Antenna height: Range = 0 cm , Measuring Speed = 8

Turntable position: Range = 30 deg , Measuring Speed = 3

Template for Single Meas.: 04_ESU_BBHA_9120_E_6GHz_pre_15109B

Subrange	Step Size	Detectors	IF BW	Meas. Time	Preamp
1 GHz - 6 GHz	400 kHz	PK+; AVG	1 MHz	0,01 s	0 dB

Receiver: [ESU 40]

Final Measurements:

Template for Single Meas.: 06_ESU_BBHA_9120_E_6GHz_fin_15109B

Subrange	Step Size	Detectors	IF BW	Meas. Time	Preamp
1 GHz - 6 GHz	400 kHz	PK+; AVG	1 MHz	0,1 s	0 dB

Receiver: [ESU 40]

Template for Single Meas.:(>1GHz) 06_ESU_BBHA_9120_E_6GHz_fin_15109B

Subrange	Step Size	Detectors	IF BW	Meas. Time	Preamp
1 GHz - 6 GHz	400 kHz	PK+; AVG	1 MHz	0,1 s	0 dB

Receiver: [ESU 40]

Report Settings:

Report Template: FCC15_109B_vert_hor

Create Electronic Report: RTF PDF

Document Name: EMI Report

Actions:

Data Reduction: Before

Notify: Sound (WAV file) 'tada.wav'

Final Measurements: After

Notify: Sound (WAV file) 'tada.wav'

Diagram No.: 2.04

Common Information

Test Description:	Radiated field strength emission in 3m distance
Test Site:	CETECOM GmbH Essen
Test Standard:	FCC 15.109B, Unintentional Radiator
Antenna polarisation:	horizontal/vertical
Operation mode:	IDLE Mode GSM850
Operator Name:	Lor
Comment:	Uplink channel middle: 182

EUT Information

EUT Name:	BGS2-W+DSB45+Handset Votronic+RS232+USB cable+Ext.antenna
Applicant:	Cinterion
Remark:	4.5V nominal internal voltage

Sweep2_SM1_K1

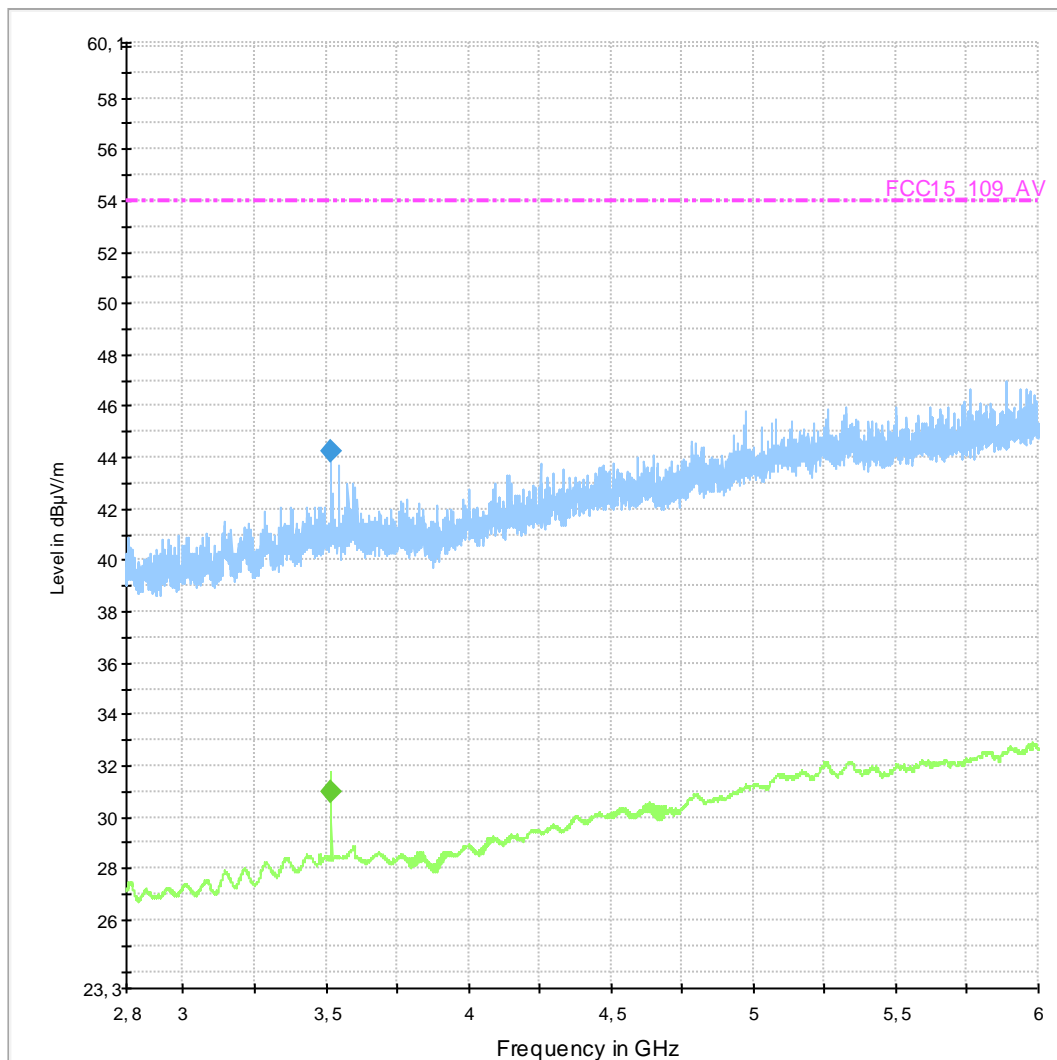

Final Result 1

Frequency (MHz)	MaxPeak (dB μ V/m)	Meas Time	Bandwidth (kHz)	Height (cm)	Polarization	Azimuth (deg)	Elevation (deg)	Corr (dB)	Margi n (dB)
3519.900000	44.2	100.0	1000.000	155.0	V	8.0	90.0	-0.7	29.8

(continuation of the "Final Result 1" table from column 10 ...)

Frequency (MHz)	Limit (dB μ V/m)	Comment
3519.900000	74.0	

Final Result 2

Frequency (MHz)	Average (dB μ V/m)	Meas Time	Bandwidth (kHz)	Height (cm)	Polarization	Azimuth (deg)	Elevation (deg)	Corr (dB)	Margi n (dB)
3519.900000	31.0	100.0	1000.000	155.0	V	-10.0	90.0	-0.7	23.0

(continuation of the "Final Result 2" table from column 10 ...)

Frequency (MHz)	Limit (dB μ V/m)	Comment
3519.900000	54.0	

EMI Auto Test Template: Sweep2_SM1_K1

Hardware Setup: 549_dBuVm_PA484_TH3_KP1_ESU
 Measurement Type: E(I)RP
 Frequency Range: 2,8 GHz - 6 GHz
 Graphics Level Range: 20 dB μ V/m - 80 dB μ V/m

Preview Measurements:
 Scan Test Template: Sweep2_pre

Data Reduction:
 Limit Line #1: FCC15_109_PK
 Limit Line #2: FCC15_109_AV
 Peak Search: 6 dB , Maximum Results: 10
 Subrange Maxima: 50 Subranges , Maxima per Subrange: 1
 Acceptance Offset: -20 dB
 Maximum Number of Results: 30
 After Data Reduction: Interactive data reduction

Frequency Zoom:
 Zoom Scan Template: Sweep2_zoom

Adjustment:
 Template for Single Meas.: Sweep2_zoom

Final Measurements:
 Template for Single Meas.: Sweep2_fin

Report Settings:
 Report Template: Report Setup FCC 15_109
 Create Electronic Report: PDF
 Document Name: dummy EMI Report

Actions:
 Test start
 Notify: "Switch-Matrix richtig geschaltet ? Spekki (ESU) angeschlossen ?"

1.6. Radiated field strength – GSM1900 RX-Mode

Diagram No. 2.01

Common Information

Test description:	Electric Field strength Measurement
Test site and distance:	Semi Anechoic Room (SAR) with 3 m measurement distance
Measured sides of EUT:	front, right, rear, left
Rec. antenna (pre-scan):	height 1.00 m and 1.82 m, horizontal and vertical polarisation
Rec. antenna (final):	height between 1 m to 4 m, polarisation according to pre-scan results
Turntable step:	90° during pre-scan, continuously turning during final measurement
Used filter:	Low-pass 1200 MHz
Test specification.:	FCC 15.109

Operator:	Tas
Operating conditions:	Idle Mode GSM850 (BCCH 651)
EUT:	BGS2-W (CINTERION); HW B2 (IMEI 00440108048446800)
Add. Equipment:	USB cable, Handset Votronic (v1.1), DSB45 box, RS 232 cable
Voltage	4,5 V DC

FCC15.109_hor+vert

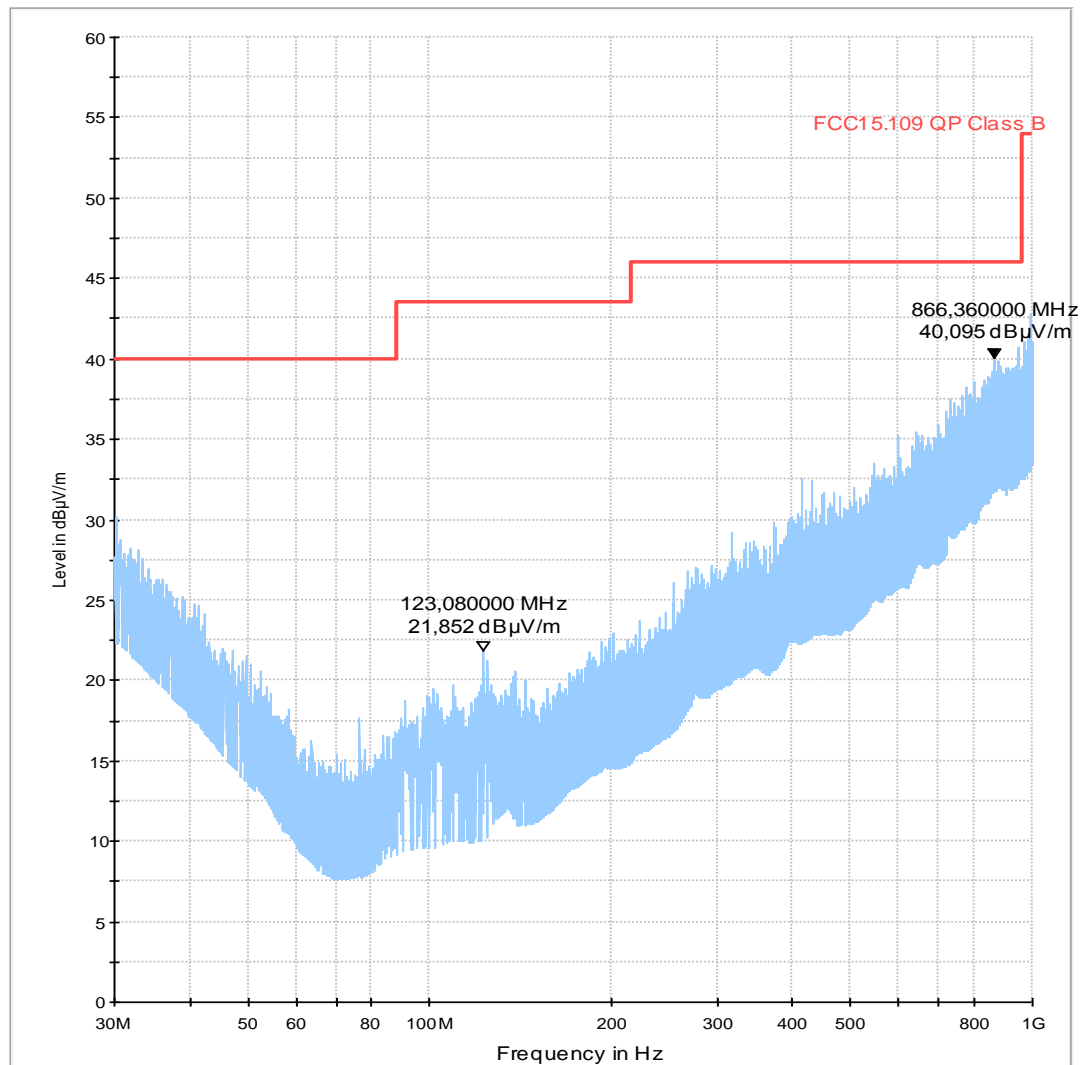

EMI Auto Test Template: FCC15.109_hor+vert

Hardware Setup: HW11_FCC_ESCS30_TP1200
 Measurement Type: Open-Area-Test-Site
 Frequency Range: 30 MHz - 1 GHz
 Graphics Level Range: 0 dB μ V/m - 60 dB μ V/m

Preview Measurements:
 Antenna height: 100 - 182 cm , Step Size = 82 cm , Positioning Speed = 8
 Polarization: H + V
 Turntable position: 0 - 270 deg , Step Size = 90 deg , Positioning Speed = 8
 Scan Test Template: EMI Scan 01_fast_FCC 15_209 B

Subrange	Step Size	Detectors	IF BW	Meas. Time	Preamp
30 MHz - 1 GHz	40 kHz	PK+	120 kHz	0,00005 s	0 dB

Receiver: [ESS]

Data Reduction:
 Limit Line #1: FCC15.109 QP Class B
 Peak Search: 6 dB , Maximum Results: 10
 Subrange Maxima: 25 Subranges , Maxima per Subrange: 1
 Acceptance Offset: -6 dB
 Maximum Number of Results: 10
 After Data Reduction: Interactive data reduction

Frequency Zoom:
 Zoom Scan Template: EMI Scan 02_20ms_zoom_FCC 15_209 B

Subrange	Step Size	Detectors	IF BW	Meas. Time	Preamp
30 MHz - 1 GHz	10 kHz	PK+	120 kHz	0,02 s	0 dB

Receiver: [ESS]

Adjustment:
 Antenna height: Adjustment with full Range , Measuring Speed = 8
 Turntable position: Adjustment with full Range , Measuring Speed = 4
 Template for Single Meas.: EMI Scan 02_20ms_FCC 15_209 B

Subrange	Step Size	Detectors	IF BW	Meas. Time	Preamp
30 MHz - 1 GHz	100 kHz	PK+	120 kHz	0,02 s	0 dB

Receiver: [ESS]

Final Measurements:
 Template for Single Meas.: EMI Scan 03_1s_FCC 15_209 B

Subrange	Step Size	Detectors	IF BW	Meas. Time	Preamp
30 MHz - 1 GHz	100 kHz	QPK	120 kHz	1 s	0 dB

Receiver: [ESS]

Report Settings:
 Report Template: FCC15_209_vert_hor
 Create Electronic Report: RTF PDF
 Document Name: EMI Report

Actions:
 Data Reduction: Before
 Notify: Sound (WAV file) 'tada.wav'
 Final Measurements: After
 Notify: Sound (WAV file) 'tada.wav'

Diagram No.: 2.05

Common Information

Test Description:	Radiated field strength emission in 3m distance
Test Site:	CETECOM GmbH Essen
Test Standard:	FCC 15.109 Unintentional Radiator
Antenna polarisation:	horizontal/vertical
Operation mode:	IDLE Mode GSM1900 (BCCH 651)
Operator Name:	Lor
Comment:	Uplink channel middle: 651
Remark:	BCCH@1958MHz on diagram

EUT Information

EUT Name:	BGS2-W+DSB45+Handset Votronic+RS232+USB cable+Ext.antenna
Applicant:	Cinterion
Remark:	4.5V nominal internal voltage

Sweep1_SM1_K1

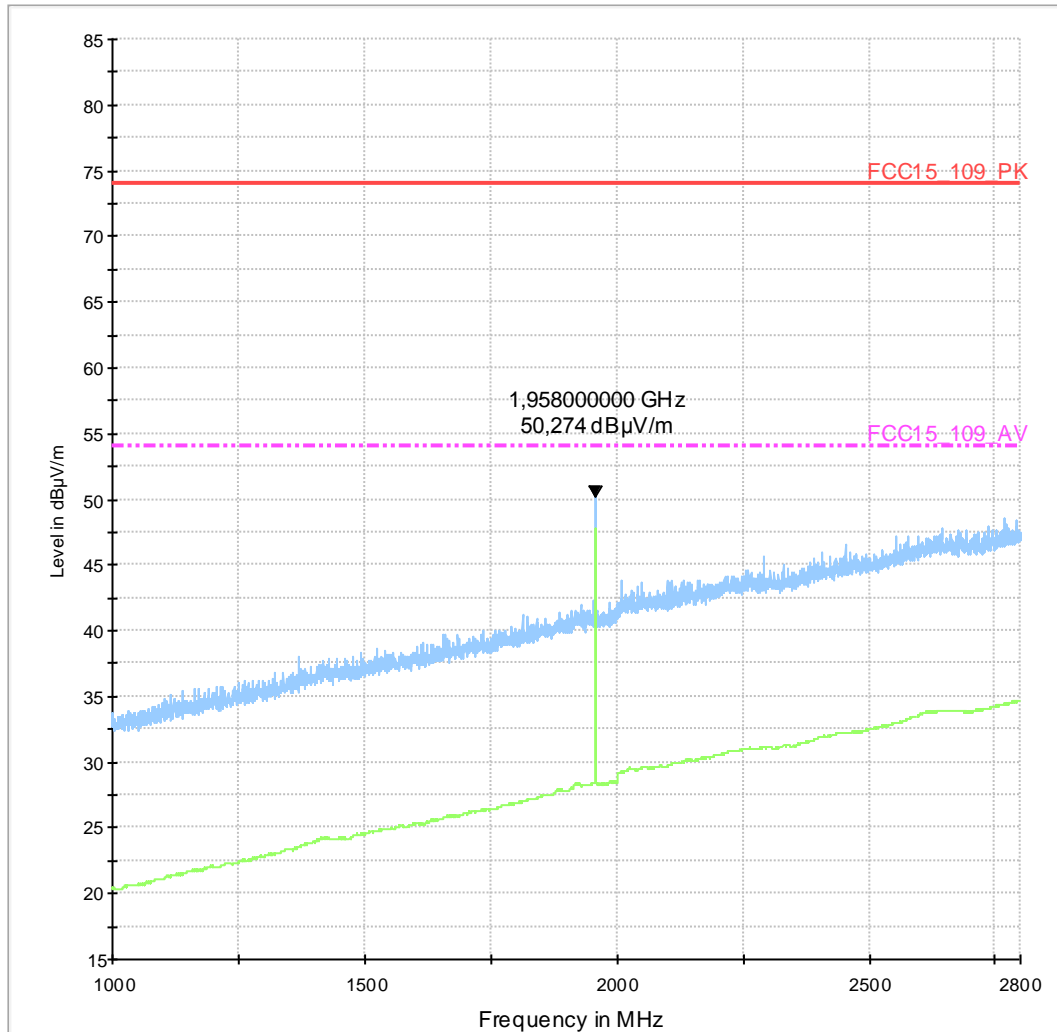

EMI Auto Test Template: Sweep1_SM1_K1

Hardware Setup: 549_dBuVm_PA287_TH1_KP1_ESU
Measurement Type: E(I)RP
Frequency Range: 1 GHz - 2,8 GHz
Graphics Level Range: 15 dB μ V/m - 85 dB μ V/m

Preview Measurements:
Scan Test Template: Sweep1_pre

Data Reduction:
Limit Line #1: FCC15_109_PK
Limit Line #2: FCC15_109_AV
Peak Search: 20 dB , Maximum Results: 10
Subrange Maxima: 50 Subranges , Maxima per Subrange: 1
Acceptance Offset: -20 dB
Maximum Number of Results: 30
After Data Reduction: Interactive data reduction

Frequency Zoom:
Zoom Scan Template: Sweep1_zoom

Adjustment:
Template for Single Meas.: Sweep1_pre

Final Measurements:
Template for Single Meas.: Sweep1_fin
Template for Single Meas.:(>1GHz) Sweep1_fin

Report Settings:
Report Template: Report Setup FCC 15_109
Create Electronic Report: RTF PDF
Document Name: dummy FCC Report

Actions:
Test start
Notify: "Matrix richtig geschaltet !?!? Spekki (ESU) angeschlossen ?"

Diagram No.: 2.06

Common Information

Test Description: Radiated field strength emission in 3m distance
 Test Site: CETECOM GmbH Essen
 Test Standard: FCC 15.109 Unintentional Radiator
 Antenna polarisation: horizontal/vertical

Operation mode: IDLE Mode GSM1900 (BCCH 651)
 Operator Name: Lor
 Comment: Uplink channel middle: 651

EUT Information

EUT Name: BGS2-W+DSB45+Handset Votronic+RS232+USB cable+Ext.antenna
 Applicant: Cinterion
 Remark: 4.5V nominal internal voltage

Sweep2_SM1_K1

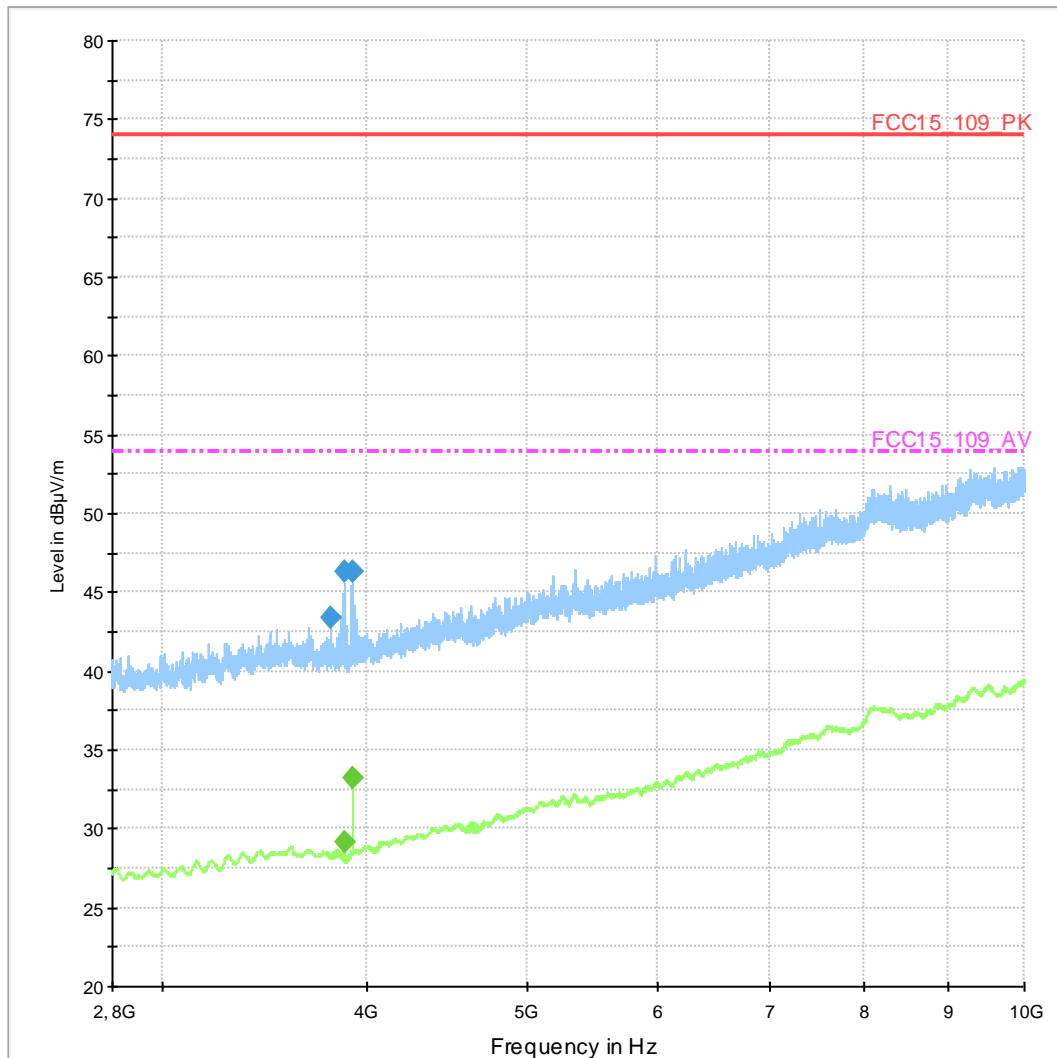

Final Result 1

Frequency (MHz)	MaxPeak (dB μ V/m)	Meas. Time	Bandwidth (kHz)	Height (cm)	Polarization	Azimuth (deg)	Elevation (deg)	Corr. (dB)	Margin (dB)
3795.300000	43.4	100.0	1000.000	155.0	V	331.0	0.0	-0.1	30.6
3871.800000	46.3	100.0	1000.000	155.0	V	338.0	0.0	0.0	27.7
3915.900000	46.3	100.0	1000.000	155.0	H	316.0	90.0	0.1	27.7

(continuation of the "Final Result 1" table from column 10 ...)

Frequency (MHz)	Limit (dB μ V/m)	Comment
3795.300000	74.0	
3871.800000	74.0	
3915.900000	74.0	

Final Result 2

Frequency (MHz)	Average (dB μ V/m)	Meas. Time	Bandwidth (kHz)	Height (cm)	Polarization	Azimuth (deg)	Elevation (deg)	Corr. (dB)	Margin (dB)
3871.400000	29.2	100.0	1000.000	155.0	V	343.0	0.0	0.0	24.8
3915.900000	33.2	100.0	1000.000	155.0	H	310.0	90.0	0.1	20.8

(continuation of the "Final Result 2" table from column 10 ...)

Frequency (MHz)	Limit (dB μ V/m)	Comment
3871.400000	54.0	
3915.900000	54.0	

EMI Auto Test Template: Sweep2_SM1_K1

Hardware Setup: 549_dBuVm_PA484_TH3_KP1_ESU
 Measurement Type: E(I)RP
 Frequency Range: 2,8 GHz - 10 GHz
 Graphics Level Range: 20 dB μ V/m - 80 dB μ V/m

Preview Measurements:

Scan Test Template: Sweep2_pre

Data Reduction:

Limit Line #1: FCC15_109_PK
 Limit Line #2: FCC15_109_AV
 Peak Search: 6 dB , Maximum Results: 10
 Subrange Maxima: 50 Subranges , Maxima per Subrange: 1
 Acceptance Offset: -20 dB
 Maximum Number of Results: 30
 After Data Reduction: Interactive data reduction

Frequency Zoom:

Zoom Scan Template: Sweep2_zoom

Adjustment:

Template for Single Meas.: Sweep2_zoom

Final Measurements:

Template for Single Meas.: Sweep2_fin

Report Settings:

Report Template: Report Setup FCC 15_109
 Create Electronic Report: PDF
 Document Name: dummy EMI Report

Actions:

Test start
 Notify: "Switch-Matrix richtig geschaltet ? Spekki (ESU) angeschlossen ?"

Annex 2: PHOTOS: TEST SET-UP
to
TEST REPORT
No.: 2-20795542c/11

According to:
FCC Regulations
FCC Part 15B
&
IC Regulations
RSS-Gen, Issue 2
RSS-132, Issue 2
RSS-133, Issue 5

for

Cinterion Wireless Modules GmbH

Quad-Band GSM/GPRS Module BGS2-W
FCC-ID: QIPBGS2
IC: 7830A-BGS2







Laboratory Accreditation and Listings			
 D-PL-12047-01-01	 MRA US-EU 0003	 Industry Canada Reg. No.: 3462D-1 3462D-2	 Reg. No.: R-2665, R-2666 C-2914, T-1967 G-301
 LAB CODE 20011130-00		 AUTHORIZED RF LABORATORY	
accredited according to DIN EN ISO/IEC 17025			
<p>CETECOM GmbH Laboratory Radio Communications & Electromagnetic Compatibility Im Teelbruch 116 • 45219 Essen • Germany Registered in Essen, Germany, Reg. No.: HRB Essen 8984 Tel.: + 49 (0) 20 54 / 95 19-954 • Fax: + 49 (0) 20 54 / 95 19-964 E-mail: info@cetecom.com • Internet: www.cetecom.com</p>			

Table of contents

1. ANNEX 1: SET-UP PHOTOS	3
1.1. Conducted emissions on AC-mains	3
1.2. Radiated emissions	3

1. Annex 1: Set-up photos

1.1. Conducted emissions on AC-mains



1.2. Radiated emissions



TEST REPORT
No.: 2-20795542b/11

According to:
FCC Regulations
 FCC Part 22H/24E
 FCC Part 15.207C
 FCC Part 15.209C
 &
IC Regulations
 RSS-132, Issue 2
 RSS-133, Issue 5
 RSS-Gen, Issue 2

for

Cinterion Wireless Modules GmbH

Quad-Band GSM/GPRS Module BGS2-W
 FCC-ID: QIPBGS2
 IC: 7830A-BGS2







Laboratory Accreditation and Listings			
 D-PL-12047-01-01	 MRA US-EU 0003	 Industry Canada Reg. No.: 3462D-1 3462D-2	 Reg. No.: R-2665, R-2666 C-2914, T-1967 G-301
 LAB CODE 20011130-00			
accredited according to DIN EN ISO/IEC 17025			
CETECOM GmbH Laboratory Radio Communications & Electromagnetic Compatibility Im Teelbruch 116 • 45219 Essen • Germany Registered in Essen, Germany, Reg. No.: HRB Essen 8984 Tel.: + 49 (0) 20 54 / 95 19-954 • Fax: + 49 (0) 20 54 / 95 19-964 E-mail: info@cetecom.com • Internet: www.cetecom.com			

Table of contents

1. SUMMARY OF TEST RESULTS.....	3
1.1. TESTS OVERVIEW FCC Part 15/22/24 and Kanada IC Standards (RSS)	3
2. ADMINISTRATIVE DATA	5
2.1. Identification of the testing laboratory	5
2.2. Test location	5
2.3. Organizational items	5
2.4. Applicant’s details	5
2.5. Manufacturer’s details	5
3. EQUIPMENT UNDER TEST (EUT)	6
3.1. Additional declaration and description of main EUT	6
3.2. Configuration of cables used for testing	6
3.3. EUT: Type, S/N etc. and short descriptions used in this test report	7
3.4. Auxiliary Equipment (AE): Type, S/N etc. and short descriptions	7
3.5. EUT set-ups	8
3.6. EUT operating modes	8
3.7. Parameter Settings on mobile phone and base station CMU200	9
4. DESCRIPTION OF TEST SET-UP’S.....	10
4.1. Test Set-up for conducted measurements	10
4.2. Test set-up for radiated measurements	12
5. MEASUREMENTS	13
5.1. RF power output (Conducted and Radiated)	13
5.2. Occupied bandwidth	17
5.3. Radiated emissions, below 30 MHz, §15.205 and §15.209C, RSS210, RSS310, RSS-gen	19
5.4. Emission limits (Spurious emission conducted/radiated)	21
5.5. Frequency stability on temperature and voltage variations.....	27
5.6. Conducted emissions on AC-Power lines.....	32
6. CALIBRATION METHOD OF ANECHOIC CHAMBER.....	34
7. MEASUREMENT UNCERTAINTIES.....	35
8. INSTRUMENTS AND ANCILLARY.....	36
8.1. Used equipment “CTC”	36
9. ANNEX – CORRECTION FACTORS DUE TO REDUCED MEAS. DISTANCE (F< 30 MHZ).....	40

Table of annex

	Total pages
SEPARATE DOCUMENT 2_20795542C_10_A1.PDF: DIAGRAMS OF TESTING	86
SEPARATE DOCUMENT 2_20795542C_10_A2.PDF: PHOTOS OF EUT	9
SEPARATE DOCUMENT 2_20795542C_10_A3.PDF: PHOTOS OF SET-UP	4

1. Summary of test results

The presented GSM 850/900/1800/1900 Module can be build inside host applications and extends their capability by wireless GSM technology. Data transmissions or voice applications are possible field applications.

In order to verify the compliance with applicable rules, a representative configuration consisting of representative auxiliary equipment was chosen. Embedded in this configuration, the GSM Module can be tested. Pls. refer to set-up description and photos for more details.

Following tests have been performed to show compliance with applicable FCC Part 2, Part 22, Subpart H and Part 24, Subpart E (Broadband PCS) of the FCC CFR 47 Rules and RSS-132, RSS-133 and RSS-Gen.

The test results apply exclusively to the test samples as presented in chapter 3.1. The CETECOM GmbH does not assume responsibility for any conclusions and generalizations taken in conjunction with other specimens or samples of the type of the item presented to tests.

1.1. TESTS OVERVIEW FCC Part 15/22/24 and Kanada IC Standards (RSS)

TEST CASES	PORT	REFERENCES & LIMITS			EUT set-up	EUT operating mode	Result
		FCC Standard	RSS Section	TEST LIMIT			
TX-Mode							
RF POWER (conducted)	Antenna terminal (conducted)	§2.1046	--	N/A	3	1+2	Passed
RF-POWER radiated (ERP/EIRP)	Cabinet	§2.1046 §22.913(a)(2) §24.232(c)	RSS-132: 4.4 SRSP-503: 5.1.3 RSS-133:4.1/6.4 SRSP-510: 5.1.2	< 7 Watt (ERP) < 2 Watt (EIRP)	1	1+2	Passed
SPURIOUS EMISSIONS (conducted)	Antenna terminal (conducted)	§2.1051 §22.917(a)(b) §24.238(a)(b)	RSS-132: 4.5.1 RSS-133: 6.5.1	43+10log(P) dBc	3	1+2	Passed
99% OCCUPIED BANDWIDTH	Antenna terminal (conducted)	§2.202 §2.1049 §22.917(a) §24.238(a)	RSS Gen:4.4.1	99% Power	3	1+2	Passed
SPURIOUS EMISSIONS (radiated)	Cabinet+ Interconnecting cables (radiated)	§15.209(a)	RSS-Gen: 4.11 RSS-210: Table 3 RSS-310: Table 4	2400/F(kHz) µV/m 24000/F(kHz) µV/m 30 µV/m	2	2	Passed
		§2.1053(a) §22.917(a)(b) §24.238(a)(b)	RSS-132: 4.5.1 RSS-133: 6.5.1	43+10log(P) dBc	1	1+2	Passed
FREQUENCY STABILITY	Antenna terminal (conducted)	§22.355, table C-1 §24.235 §2.1055	RSS-132: 4.3 RSS-133: 6.3	< 2.5ppm <0.1 ppm	3	1+2	Passed
AC-Power lines Conducted emissions	AC-mains	§15.207	RSS-Gen, Issue 2, Chapter 7.2.2	FCC §15.207, limits IC: Table 2, Chapter 7.2.2	4	1+2	Passed

RX Mode							
Receiver conducted emissions	Antenna terminal (conducted)	§2.1051 §15.111	RSS-Gen: 6(b) RSS-132: 4.6 RSS-133: 6.7(b)	FCC: < 2nW IC: < 2 nW/4kHz (30<f<1000 MHz) < 5nW/4kHz (f> 1GHz)	Remark 1	Remark 1	Passed Remark 1
AC-Power lines Conducted emissions	AC-power lines	§15.107, class B	RSS-Gen, Issue 2, Chapter 7.2.2	FCC §15.107, class B limits IC: Table 2, Chapter 7.2.2	Remark 1	Remark 1	Passed Remark 1

Remark:

- 1.) See separate test report 2_20795542c/11 and corresponding annexes for measurements according Part 15, Subpart B.

ATTESTATION:

I declare that all measurements were performed by me or under my supervision and that all measurements have been performed and are correct to my best knowledge and belief to Industry Canada standards. All requirements as shown in above table are met in accordance with enumerated standards.

.....
Dipl.-Ing. W. Richter
Responsible for testsection



GmbH
Im Teebruch 116
45219 Essen
Tel: + 49 (0) 20 54 7 95 19 - 0
Fax: + 49 (0) 20 54 7 95 19 - 337

.....
Dipl.-Ing. C. Lorenz
Responsible for test report

2. Administrative Data

2.1. Identification of the testing laboratory

Company name:	CETECOM GmbH
Address:	Im Teelbruch 116 45219 Essen - Kettwig Germany
Laboratory accreditations/Listings:	DAkkS-Registration No. D-PL-12047-01-01 MRA US-EU 0003 IC-Registration No. 3462D-1, 3462D-2 VCCI Registration No. R-2665,R-2666,C-2914,T-339
Responsible for testing laboratory:	Dipl.-Ing. W. Richter
Deputies:	Dipl.-Ing. J.Schmitt

2.2. Test location

2.2.1. Test laboratory "CTC"

Company name:	see chapter 2.1. Identification of the testing laboratory
---------------	---

2.3. Organizational items

Order No.:	20795542
Responsible for test report and project leader:	Dipl.-Ing. C. Lorenz
Receipt of EUT:	2011-02-02
Date(s) of test:	2011-02-03 - 2011-02-17
Date of report:	2011-03-02

Version of template:	09.06 _All.Dotm

2.4. Applicant's details

Applicant's name:	Cinterion Wireless Modules GmbH
Address:	Siemensdamm 50 13629 Berlin Germany
Contact person:	Mr. Stefan Ludwig

2.5. Manufacturer's details

Manufacturer's name:	please see Applicant's details
Address:	please see Applicant's details

3. Equipment under test (EUT)

3.1. Additional declaration and description of main EUT

Main function	GSM/GPRS Quad-Band Module		
Type	BGS2-W		
GSM Frequency range (USA/Canada bands)	GSM 850: 824 – 849MHz (Uplink), 869-894MHz (Downlink) GSM1900: 1850-1910MHz (Uplink), 1930-1990MHz (Downlink)		
Type of modulation	GMSK		
Number of channels (USA/Canada bands)	GSM 850: 128 – 251, 125 channels GSM1900: 512 – 810, 300 channels		
EMISSION DESIGNATOR(S)	245KGXW		
Antenna Type: External magnet mount antenna for vehicular use	<input type="checkbox"/> Integrated <input type="checkbox"/> External, no RF- connector <input checked="" type="checkbox"/> External, separate RF-connector	Frequency range: GSM 850: 824 – 894 MHz GSM 1900: 1850-1990 MHz	
Antenna Gain	<input checked="" type="checkbox"/> radiated: Max. 2 dBi gain at GSM1900		
MAX PEAK Output Power: Radiated ERP Radiated EIRP	GSM850 GSM1900	29,01 dBm (Burst PK) 27,60 dBm (Burst PK)	
MAX PEAK Output Power: Conducted Conducted	GSM 850 GSM1900	32,40 dBm (PK) 29,89 dBm (PK)	
FCC-ID	QIPBGS2		
IC	7380A-BGS2		
Installed option	<input checked="" type="checkbox"/> GSM900 and GSM1800 Bands		
Special EMI components	--		
Power supply	Internally supplied and controller by the DSB75 Board for tests: $V_{MIN}=3.3V$ to $V_{MAX}=4.5V$ DSB75 Box was DC supplied with 9V external power supply		
EUT sample type	<input type="checkbox"/> Production	<input checked="" type="checkbox"/> Pre-Production	<input type="checkbox"/> Engineering

3.2. Configuration of cables used for testing

Cable number	Item	Type	S/N serial number	HW hardware status	Cable length
Cable 1	RS232	unshielded	CTC	--	1.8m
Cable 2	USB cable	shielded	CTC	--	1.5m

3.3. EUT: Type, S/N etc. and short descriptions used in this test report

Short description*)	EUT	Type	S/N serial number	HW hardware status	SW software status
EUT A	Quad-Band GSM/GPRS Module	BGS2-W	IMEI: 004401-08-048446-8	B2.1	00.960
EUT B	Magnetic Mount antenna	MAR-C3G-2F	CTC#1	2dBi Gain	--
EUT C	Handset Votronic	For M20T, MC35T, TC35T, DSB35	4017953211304	HH-SI-30.3/V2.0/0	--
EUT D	Adapter Board for BGS2-W	Ven_60/80_0035	#1	--	--
EUT E	DSB Board + flat ribbon connection+ Adapter BG2_PH8_Ada_0207	DSB75	0911007 ICM-100012-03	B1.1	--
EUT F	Quad-Band GSM/GPRS Module	BGS2-W	IMEI: 004401-08-048449-2 (WMC0004AD0a)	B2.1	00.960

*) EUT short description is used to simplify the identification of the EUT in this test report.

3.4. Auxiliary Equipment (AE): Type, S/N etc. and short descriptions

AE short description *)	Auxiliary Equipment	Type	S/N serial number	HW hardware status	SW software status
AE 1	Notebook	Dell D610D	CTC PC3	--	Windows XP + Terminal program
AE 2	AC/DC Adapter	FW7238/09	1401	Input: 100V – 240 V AC/50-60Hz/180mA Output: 9V DC/800mA	--

*) AE short description is used to simplify the identification of the auxiliary equipment in this test report.

3.5.EUT set-ups

EUT set-up no. *)	Combination of EUT and AE	Remarks
Set. 1	EUT A + EUT B+ EUT C + EUT D + EUT E + AE1	set-up used for tests: radiated
Set. 2	EUT F + EUT B +EUT C + EUT D + EUT E + AE1	set-up used for tests: radiated
Set. 3	EUT F + EUT B + EUT C + EUT D + EUT E + AE1	set-up used for conducted RF-tests
Set. 4	EUT A + EUT B+ EUT C + EUT D + EUT E + AE1 + AE2	set-up used for tests: conducted according EMI-AC Power line

*) EUT set-up no. is used to simplify the identification of the EUT set-up in this test report.

3.6. EUT operating modes

EUT operating mode no. *)	Description of operating modes	Additional information
op. 1	GSM 850 TCH mode TCH=128/192/251	A communication link is established between the mobile station and the test simulator. The transmitter is operated at its maximum rated output power: 33 dBm (power class 4; power control level 5). The input signal to the receiver is modulated with normal test modulation. The wanted RF input signal level to the receiver of the mobile station is set to a level to provide a stable communication link.
op. 2	GSM 1900 TCH mode TCH=512/661/810	A communication link is established between the mobile station and the test simulator. The transmitter is operated at its maximum rated output power: 30 dBm (power class 1; power control level 0). The input signal to the receiver is modulated with normal test modulation. The wanted RF input signal level to the receiver of the mobile station is set to a level to provide a stable communication link

*) EUT operating mode no. is used to simplify the test report.

3.7. Parameter Settings on mobile phone and base station CMU200

Following settings apply to the MS during the measurements in **GSM/(E)GPRS-Mode** only:

Parameter	Traffic Mode	Idle Mode
Traffic Channels mobile station (EUT)	GSM 850 TCH _{MS} = 128/ 192 /251 GSM 1900 TCH _{MS} = 512 / 681 / 810	--
maximum power level (PCL)	GSM 850: PCL = 5 (2 Watt) GSM 1900: PCL = 0 (1 Watt)	--
Modulation	GSM: GMSK-Modulation Scheme EDGE: 8-PSK Modulation Scheme	--
DTX	off	--
Bitstream	PRBS 2E9-1 (pseudo-random-sequence) – CCITT 0.153	
Timeslot	3	
Hopping	off	
Timeslot (slot mode)	GSM-Mode: single GPRS-Mode: maximum allowed uplink slots no. according MS class	
MS slot class	Class 10	
Maximum data transmission rate, single time slot	GSM: 17,6 kBit/s Slot EDGE: 59,2 kBit/s Slot	
Speech transcoding (Traffic Mode)	Full rate Version 1	
Mode	BCCH and TCH	
BCCH – base station (CMU,CMD)		GSM 850: 182 GSM 1900: 651
TCH – base station (CMD, CMU)	auto	
Power level TCH – base station (used timeslot level)	- 70 dBm	
Power level BCCH – base station (control channel level)	- 80 dBm	
External attenuation RF/AF-Input/Output	Accord. calibration prior to measurements	
Mobile Country Code	310	310
BS_AG_BLK_RES		0
Paging reorganisation		Off (0)
Signalling channel	Not applicable	SDCCH
Location Update		Auto
Cell access		Disabled (barred)

Settings for CMU (general)

Repetition	Continuous
Stop condition	None
Display mode	Max./Min
Statistic Count	1000 Bursts
Decoder	Standard

Additional settings on the base stations CMU200 for frequency stability measurements

4. DESCRIPTION OF TEST SET-UP'S

4.1. Test Set-up for conducted measurements

The EUT's RF-signal is coupled out by a suitable antenna coupling connector (1). The signal is first 10 dB attenuated (2) before it is 0° divided by a power divider (3). One of the signal path is connected to the communication base station (4), other branch is connected to the spectrum – analyzer (6). The specific attenuation losses for both signal paths/branches are determined prior to the measurement within a set-up calibration. These are then taken into account by correcting the measurement readings on the spectrum-analyzer.

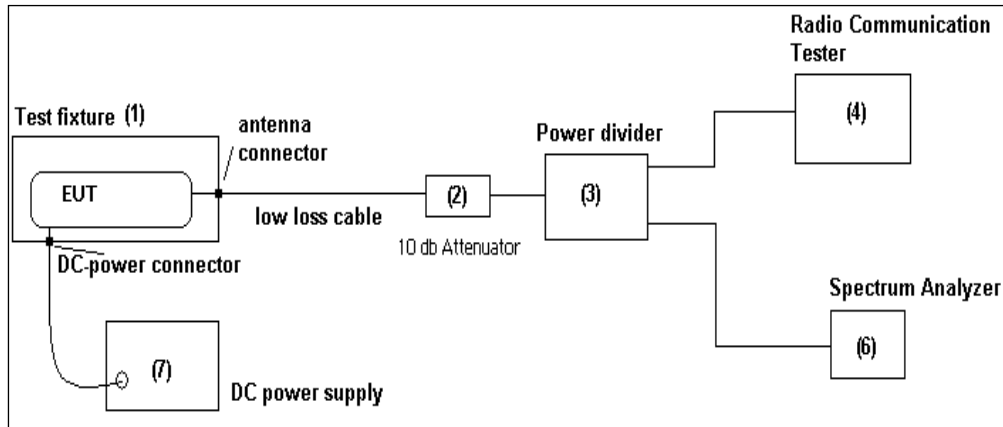

Schematic 1: Test set-up conducted in the Radio Laboratory for occupied bandwidth, frequency stability and spurious emissions measurements.

The EUT's RF-signal is coupled out by a suitable antenna coupling connector (1). The signal is first 6 dB attenuated (2) before it is connected to the co communication base station CMU200 (3). The specific attenuation losses for signal path is determined prior to the measurement within a set-up calibration. These are then taken into account by correcting the measurement readings on the communication base station (3).

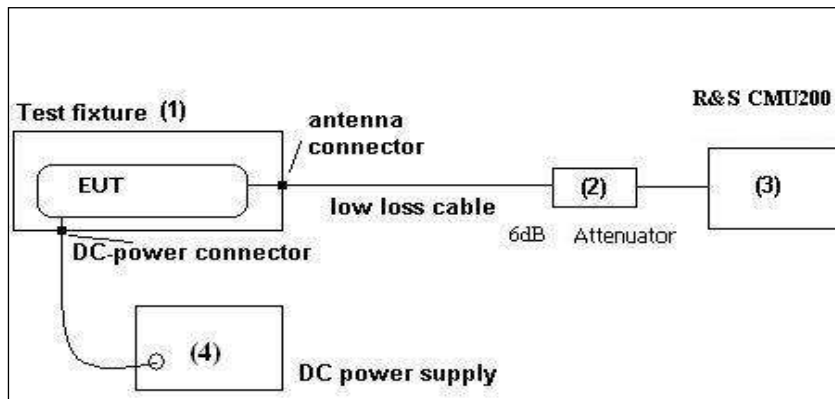

Schematic 2: Test set-up conducted for maximum output power measurements.

Following modified test set-up schematic apply for tests performed inside the climatic chamber:
Frequency stability

In case an external connector is available (test fixture), following set-up is used for measurements.

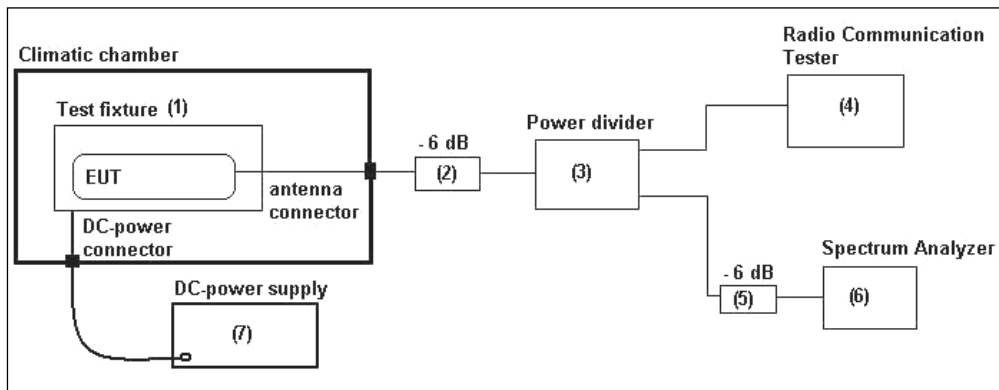

Schematic 3: Test set-up conducted within climatic chamber

4.2. Test set-up for radiated measurements

The radiated emissions from the test device are measured first as exploratory measurement in a FCC recognized semi anechoic chamber (registration no. 99538) or fully anechoic chamber with the dimensions of 8.05m x 6.85m x 5.48m. Very critical frequencies within a defined range, can be re-checked on CETECOM's Open Area Test side, recognized by the FCC to be compliant with ANSI 63.4: 2003 according registration no. 99538

The EUT and accessories are placed on a non-conducting tipping table of 0.8 meter height (semi-anechoic chamber) or 1.55m height (fully-anechoic chamber) which is situated in the middle of the turntable. The turntable can rotate the device under test 360 degree, the tipping table can rotate the device from laid to standing position. This way the device under test can be rotated in all three orthogonal planes in order to maximize the detected emissions. The turn- and tipping table are controlled by a controller unit. All positions manipulations are software controlled from a operator PC.

The measurements are performed for both receiving antenna polarisations: vertical and horizontal.

Up to 18GHz a measurement distance of 3 meters is used, above 18GHz the distance is 1meter. A biconical-logarithmic antenna up to 1 GHz and a horn antenna for frequencies above 1 GHz used. (see equipment list)

The EUT is powered either by a external DC-supply with nominal voltage or a AC/DC power supply as accessory. The communication signalling is performed from outside the chamber with a communication test simulator (CMU200 from Rohde&Schwarz) by airlink.

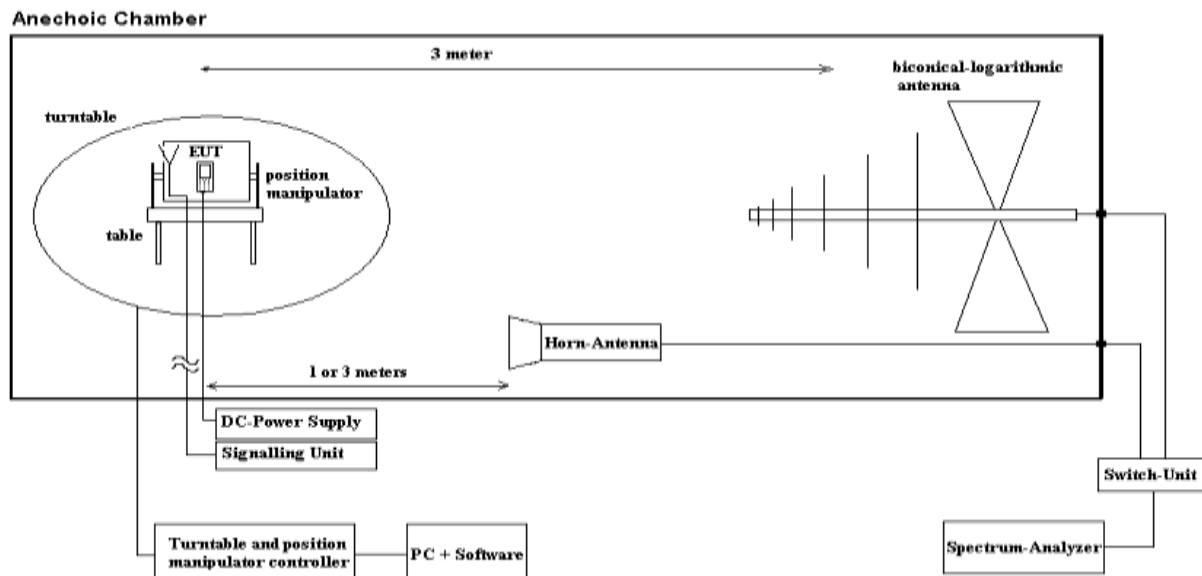

Schematic: radiated measurements test set-up

5. Measurements

5.1. RF power output (Conducted and Radiated)

REFERENCES

FCC: §2.1046 (conducted), §22.913(a)(2), § 24.232(c)

IC: RSS-132:4.4 + SRSP 503:5.1.3 for GSM 850; RSS-133:6.4 + SRSP-510:5.1.2 for GSM 1900

- Maximum Power Output of the mobile phone should be determined while measured conducted and radiated way.

TEST SET-UP (CONDUCTED)

- see conducted measurement set-up, description in chapter 4.1, schematic 2
- a suitable artificial antenna or RF-connector is provided by the applicant in order to perform the conducted measurements. Any data provided with the artificial antenna or connector, have been taken in account in order to correct the measurement data.

MOBILE PHONE SETTINGS

- according 3.7

BASE STATION SETTING

- according 3.7

TEST METHOD

- 1.) The measurements were made at the upper, middle and lower carrier traffic frequencies of the operating band. Choosing three TX-carrier frequencies of the mobile phone within each operable GSM band, should be sufficient to demonstrate compliance.
- 2.) The measurements were performed with the integrated power measurement function of the „radio communication tester *CMU* from *Rohde&Schwarz* company. In this way spectrum-analyzers instrument limitations can be avoided or minimized. Instead, *CMU* manufacturers declared measurement error can be considered for this measurement.
- 3.) The attenuation (insertion loss) at the RF Inputs/Outputs of *CMU* were set according the path loss of the test set-up, determined in a step before starting the measurements.
- 4.) PK and Average values have been recorded for each channel and band.

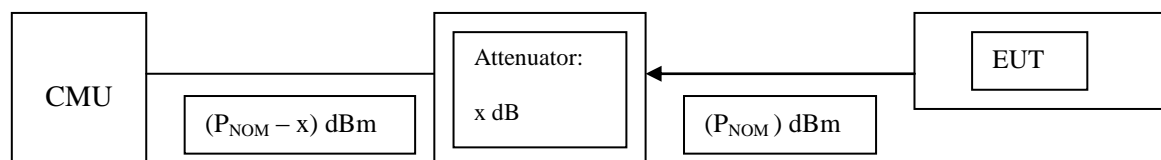

RESULTS (CONDUCTED)

Op. Mode 1, Set-up 3

Channel/ Frequency (MHz)		Peak Output Power (dBm)	Average Output Power (dBm)
GSM 850	Channel 128/ 824.2 MHz	32.1	32.0
	Channel 190/ 836.6 MHz ^{*)}	32.3	32.1
	Channel 192/ 837.0 MHz	32.3	32.2
	Channel 251/ 848.8 MHz	32.4	32.3

Remark: -

*) Channel 190 was tested for customers information too

Op. Mode 2, Set-up 3

Channel/ Frequency (MHz)		Peak Output Power (dBm)	Average Output Power (dBm)
GSM 1900	Channel 512/ 1850.2 MHz	29.2	29.0
	Channel 661/ 1880.0 MHz	29.6	29.4
	Channel 810/ 1909.8 MHz	29.9	29.7

Remark: -

PAR factor for GSM Modulation is approx 0.1 to max. 0.2 far away from the limit of 13dB as stated in the rules.

VERDICT: Passed

AMBIENT ENVIRONMENTAL CONDITIONS

Temperature	21.5 °C
Relative Humidity	40.5 %
Air pressure	1008 hPa

TEST EQUIPMENT

Used equipment (see reference in the annex)
R&S CMU200 Ref. No. 436, Cable OTA20, attenuator 6dB, Ref. No. 248

5.1.1. Radiated RF-Power

TEST METHOD

The measurements were made at the upper, center, and lower carrier traffic frequencies of each of the supported operating band. Choosing three TX-carrier frequencies of the mobile phone, should be sufficient to demonstrate compliance.

The measurements were performed by using the **substitution method** (ANSI/TIA/EIA 603) with a spectrum-analyzer. This method can be described like follows:

- 1.) choosing of suitable spectrum-analyzer settings for performing the measurements. This settings of the spectrum analyzer must be maintained for both stages of the measurements: EUT emission measurements and also for measurements of the substituted level.

Parameter	Setting for GSM measurements	Settings for UTRA/FDD measurements
RBW	1 MHz	10 MHz
VBW	10 MHz	10 MHz
Span	8 MHz	8 MHz
Detector Mode	Positive max-hold	Positive max-hold
Average	off	off
Sweep Time	coupled	coupled

- 2.) The maximum level of the peak power was recorded, while the emissions were maximized by rotating the EUT in three orthogonal axes, which was situated on a non-conductive turntable of 1.55 m height ($P_{MEAS,1}$). This was performed for both measuring antenna polarisations (vertical/horizontal), the maximum of both values is used for further measurements and final substitution ($P_{MEAS,1,MAX}$).
- 3.) As the maximum emission is recorded, the EUT is replaced by a frequency dependant suitable antenna, which is connected to a RF-signal generator, which is transmitting on the determined worst-case frequency as determined in step 2.
- 4.) The RF-signal level of the signal generator is adjusted as long the same worst-case level determined first step is measured at the spectrum analyzer ($P_{SMHU}=P_{MEAS,1,MAX}$)
- 5.) Than the RF-signal cable is disconnected from the antenna and connected to a power-level meter. The level is determined ($P_{MEAS,2}$).
- 6.) The final result is calculated by adding the ERP/EIRP gain of the antenna which substitutes the EUT.
 $P_{EUT,SUBST} = P_{MEAS,2} + G_{Antenna}$

GSM RESULTS (RADIATED):

OP. MODE 1, SET-UP 1

Channel/ Frequency (MHz)		Peak Output Power (dBm)		Antenna Polarisation for maximum Power	Verdict	
		PK	AV			
GSM 850	Channel 128/ 824.2 MHz	25.06	1.)	ERP-Value	V/H	Passed
	Channel 192/ 837.0 MHz	29.01				
	Channel 251/ 848.8 MHz	23.81				
E-GPRS 850	Channel 128/ 824.2 MHz	Not supported mode		ERP-Value	V/H	--
	Channel 192/ 837.0 MHz					
	Channel 251/ 848.8 MHz					

Remark: -

- 1.) PAR factor can be used from conducted measurement and subtracted from radiated ERP PK-value.

Op. Mode 2, Set-up 1

Channel/ Frequency (MHz)		Peak Output Power (dBm)		Antenna Polarisation for maximum Power	Verdict	
		PK	AV			
GSM 1900	Channel 512/ 1850.2 MHz	27.25	1.)	EIRP-Value	V/H	Passed
	Channel 661/ 1880.0 MHz	27.59				
	Channel 810/ 1909.8 MHz	27.42				
E-GPRS 1900	Channel 512/ 1850.2 MHz	Not supported mode		EIRP-Value	V/H	--
	Channel 661/ 1880.0 MHz					
	Channel 810/ 1909.8 MHz					

Remark: -

1.) PAR factor can be used from conducted measurement and subtracted from radiated EIRP PK-value.

AMBIENT ENVIRONMENTAL CONDITIONS

Temperature	20.2 °C
Relative Humidity	46 %
Air pressure	1011 hPa

TEST EQUIPMENT

Used equipment at FAR system[Ref. No.443] (see reference in the annex)
549, 443, 439, 264, 460

5.2. Occupied bandwidth

REFERENCES

FCC: §2.1049; §22.917(a), §24.238(a)
 IC:RSS-Gen:4.6.1

„the **occupied bandwidth** is the frequency bandwidth, such that, below it lower and above it upper frequency limits, the mean powers radiated are each equal to 0.5 percent of the total mean power radiated.

TEST SET-UP

- see conducted measurement set-up described in 4.1, schematic 1

MOBILE PHONE SETTINGS

- Provisions with the requirements is based on the fact, that GSM modulation scheme is GMSK Modulation for GSM equipment with a maximum data transmission rate of 17,6 kBit/s per Slot.
- Provisions with the requirements is based on the fact, that EDGE modulation scheme is 8-PSK Modulation for EDGE equipment with a maximum data transmission rate of 69,2 kBit/s per Slot.
- according settings described in chapter 3.7 a call was established

SETTINGS OF THE SPECTRUM-ANALYSER

Frequency range	RBW (resolution bandwidth)	VBW (video bandwidth)
<i>1 MHz around carrier frequency</i>	<i>1% from applicants stated/measured emission bandwidth</i>	<i>3..10 times the RBW</i>

TEST METHOD

The measurements were made at the upper, middle and lower carrier traffic frequencies of the operating band. Choosing three TX-carrier frequencies of the mobile phone within each operable GSM band, should be sufficient to demonstrate compliance

Additionally the emission bandwidth (-26 dBc bandwidth) was recorded for all three channels. The results were taken in order to determine according the §24.238 the measurement resolution bandwidth, which should be approximately 1% of the emission bandwidth.

RESULTS

Set-up 3, Op-Mode 1

Channel/ Frequency (MHz)	Occupied 99% bandwidth [kHz]	Emission bandwidth [kHz]
GSM 850	Channel 128/ 824.2 MHz	245.192
	Channel 192/ 837.0 MHz	245.192
	Channel 251/ 848.8 MHz	245.192
		315.705
		317.307
		314.102

Remarks: See separate document A1 for more details

Set-up 3, Op-Mode 2

Channel/ Frequency (MHz)		Occupied 99% bandwidth [kHz]	Emission bandwidth [kHz]
GSM 1900	Channel 512/ 1850.2 MHz	245.192	314.102
	Channel 661/ 1880.0 MHz	245.192	315.705
	Channel 810/ 1909.8 MHz	245.192	312.500

Remarks: See separate document A1 for more details

AMBIENT ENVIRONMENTAL CONDITIONS

Temperature	19.8 °C
Relative Humidity	39 %
Air pressure	1007 hPa

TEST EQUIPMENT

Used equipment at the Radio Laboratory [ref.no. 347] (see reference in the annex)
298, 354, 468, 489, 529, 530, 517 (RF-Relay Unit Keithley)

5.3. Radiated emissions, below 30 MHz, §15.205 and §15.209C, RSS210, RSS310, RSS-gen
TEST LOCATION AND EQUIPMENT (for reference numbers please see chapter 'List of test equipment')

test location	<input checked="" type="checkbox"/> CETECOM Essen)		<input type="checkbox"/>	<input type="checkbox"/>	<input type="checkbox"/>	<input type="checkbox"/>
test site	<input checked="" type="checkbox"/> 441 EMI SAR	<input type="checkbox"/> 487 SAR NSA	<input type="checkbox"/> 337 OATS	<input type="checkbox"/> 347 Radio.lab.	<input type="checkbox"/>	<input type="checkbox"/>
receiver	<input type="checkbox"/> 377 ESCS30	<input checked="" type="checkbox"/> 001 ESS	<input type="checkbox"/>	<input type="checkbox"/>	<input type="checkbox"/>	<input type="checkbox"/>
spectr. analys.	<input type="checkbox"/> 381 380 FSBS	<input type="checkbox"/> 120 FSEM	<input type="checkbox"/> 264 FSEK	<input type="checkbox"/>	<input type="checkbox"/>	<input type="checkbox"/>
antenna	<input type="checkbox"/> 048 EMCO3143	<input type="checkbox"/> 133 EMCO3115	<input type="checkbox"/> 302 BBHA9170	<input type="checkbox"/> 289 CBL 6141	<input checked="" type="checkbox"/> 030 HFH-Z2	<input type="checkbox"/> 477 GPS
signaling	<input type="checkbox"/> 298 CMU	<input type="checkbox"/> 460 CMU	<input type="checkbox"/> 295 RACAL	<input checked="" type="checkbox"/> 392 MT8820A		
power supply	<input checked="" type="checkbox"/> 456 EA 3013A	<input type="checkbox"/> 457 EA 3013A	<input type="checkbox"/> 459 EA 2032-50	<input type="checkbox"/> 268 EA- 3050	<input type="checkbox"/> 494 AG6632A	<input type="checkbox"/> 498 NGPE 40
otherwise	<input type="checkbox"/> 400 FTC40x15E	<input type="checkbox"/> 401 FTC40x15E	<input type="checkbox"/> 110 USB LWL	<input type="checkbox"/> 482 Filter Matrix		

STANDARDS AND LIMITS: CFR 47, PART 15, SUBPART B, §15.205, §15.209, ANSI C63.4:2003

Frequency [MHz]	Field strength		Measurement distance [meters]	Remarks
	[µV/m]	[dBuV/m]		
0.009 – 0.490	2400/f (kHz)	67.6 – 20Log(f) (kHz)	300	Correction factor used due to measurement distance of 3m
0.490 – 1.705	24000/f (kHz)	87.6 – 20 Log(f) (kHz)	30	Correction factor used due to measurement distance of 3m
1.705 – 30	30	29.54	30	Correction factor used due to measurement distance of 3m

Remark: * decreases with the logarithm of the frequency

TEST CONDITION AND MEASUREMENT TEST SET-UP

link to test system (if used):	<input checked="" type="checkbox"/> air link	<input type="checkbox"/> cable connection	<input type="checkbox"/>
EUT-grounding	<input checked="" type="checkbox"/> none	<input type="checkbox"/> with power supply	<input type="checkbox"/> additional connection
Equipment set up	<input checked="" type="checkbox"/> table top		<input type="checkbox"/> floor standing
Climatic conditions	Temperature: (24°C)		Rel. humidity: (30)%
EMI-Receiver (Analyzer) Settings	Span/Range: 9kHz to 150kHz; 150 kHz to 30 MHz RBW/VBW: 200Hz/auto; 10 kHz/ auto (CISPR#16) Detector/ Mode: PEAK, TRACE max-hold mode, repetitive scan for exploratory measurements Quasi-Peak, for final measurement on critical frequencies (fy<1GHz)		

GENERAL MEASUREMENT PROCEDURES:

The measurement test set-up and test procedure are in accordance with the provisions described in ANSI 63.4: 2009

The **Equipment under Test** (EUT) was set-up to defined operating mode and installed (connected) to accessory equipment according the general description of use given by the applicant.

The measurement loop antenna was situated in 3m distance to the EUT. Radiated magnetic emission measurements were made with the antenna situated in 1 meter height. The loop antenna was moved at least to 2-perpendicular axes (antenna vector in direction of EUT and parallel to EUT) in order to maximize the emissions, the EUT itself either over 3-orthogonal axes (no defined usage position) or 2-orthogonal axis (defined usage position) by the position manipulator.

According the standard the compliance should be checked in 30m and 300m measurement distance. Therefore a additional extrapolation factor was used in order to normalize the measurement data. The frequency dependent extrapolation factor used for this reduced measurement distance, can be found in the chapter 9.

MEASUREMENT RESULTS

Channel 512

Set-up No.		2								
Operating Mode		2								
Diagram no.	Frequency (MHz)	MaxPeak (dBµV/m)	Meas. Time (ms)	Bandwidth (kHz)	Antenna height (cm)	Polarity	Turntable position (deg)	Corr. (dB) (C _F)	Margin (dB) (M)	Limit (dBµV/m) (L _T)
3.01	--	<15.48	1000	0.2/10.00	100.00	Parallel and 90° to the EUT	0..360°	See below Abbreviation	>14 dB	below Limit

Remark: External Interferer between 17,2 kHz – 100 kHz, see also plots enclosed in annex 1

Channel 661

Set-up No.		2								
Operating Mode		2								
Diagram no.	Frequency (MHz)	MaxPeak (dBµV/m)	Meas. Time (ms)	Bandwidth (kHz)	Antenna height (cm)	Polarity	Turntable position (deg)	Corr. (dB) (C _F)	Margin (dB) (M)	Limit (dBµV/m) (L _T)
3.02	--	<14.54	1000	0.2/10.00	100.00	Parallel and 90° to the EUT	0..360°	See below Abbreviation	>15 dB	below Limit

Remark: External Interferer between 17,2 kHz – 100 kHz, see also plots enclosed in annex 1

Channel 810

Set-up No.		2								
Operating Mode		2								
Diagram no.	Frequency (MHz)	MaxPeak (dBµV/m)	Meas. Time (ms)	Bandwidth (kHz)	Antenna height (cm)	Polarity	Turntable position (deg)	Corr. (dB) (C _F)	Margin (dB) (M)	Level (dBµV/m) (L _T)
3.03	--	< 15	1000	0.2/10.00	100.00	Parallel and 90° to the EUT	0..360°	See below Abbreviation	>18 dB	Below Limit

Remark: External Interferer between 17,2 kHz – 100 kHz, see also plots enclosed in annex 1

<p>Margin to Limit:</p> $M = L_T - R_R + C_F + D_F$ $= L_T - R_R + (AF_{ANTENNA} + Cable_{LOSS}) + D_F$ <p>Remark: positive margin means passed result</p>	<p>Abbreviations used:</p> <ul style="list-style-type: none"> • R_R : Receiver readings in dBµV/m • C_F: Transducer in dB = AF (antenna factor) + CL (cable loss) • D_F: distance correction factor (if different measurement distance used than specified in the standard) • L_T : Limit in dBµV/m
---	--

VERDICT

Radiated frequencies below 30 MHz: Passed

5.4. Emission limits (Spurious emission conducted/radiated)

REFERENCES

FCC: §2.1051-conducted, §15.111-conducted antenna terminal, §2.1053(a)-radiated, §22.917(a)(b); §24.238(a)(b), §2.1057(1)

IC: RSS-132:4.5.1, RSS-133:6.5.1 - TX-mode
 RSS-132:4.6, RSS-133: 6.7(b) – RX-mode

„the power of emissions shall be attenuated below the transmitter output power (p) by at least least $43+10\text{Log}(P)$ dB“

FREQUENCY RANGE

TX: The spectrum was scanned from 30 MHz to the 10th harmonic of the highest frequency generated within the equipment. The detector used was Peak.

Limit TX: The specification that all emissions shall be attenuated below the transmitter power (P) by at least $43 + 10 \log (P)$ dB, translates in the relevant power range of the mobile phone (1 to 0.001 W) to a constant limit of -13 dBm.

DESCRIPTION OF SET-UP

- see conducted set-up in chapter 4.1
- see radiated set-up in chapter 4.2

SETTINGS ON MOBILE PHONE

- The measurements in TX-mode were made at the upper, middle, and lower carrier frequencies of the operating band. Choosing three representative TX-carrier frequencies of the mobile phone within each operable GSM band, should be sufficient to demonstrate compliance with the emissions limits outside and adjacent to the frequency blocks.
- The measurements in RX-Mode were made at the middle tuning range of the receiver.
- The individual settings on base station and mobile phone were made according chapter 3.7

TEST METHOD RADIATED:

By rotating the EUT in three orthogonal planes, the emissions were recorded with Peak-Detector and Hold-Max function of the spectrum-analyzer. If the harmonic could not be detected above the noise floor, the ambient level was recorded. Measurement distance is 3m for frequencies up to 18GHz and 1m for frequencies greater then 18GHz. The readings on the spectrum analyzer are corrected with annually performed chamber path calibration values (see chapter 7), so the readings shown are equivalent to ERP/EIRP values. Critical measurements near the limit, are re-measured with a substitution method accord. ANSI/TIA/EIA 603.

SETTINGS OF SPECTRUM-ANALYSER

Frequency range	RBW (resolution bandwidth)	VBW (video bandwidth)
BAND-EDGE compliance: 1MHz immediately adjacent to the frequency blocks	1% from applicants stated/measured emission bandwidth	3..10 times the RBW
More than 1 MHz outside and adjacent the frequency blocks	1 MHz	3..10 MHz

RESULTS (CONDUCTED)

5.4.0.1. GSM TCH 850: Op. Mode 1, Set-up 3

Lowest channel: 128

Transmitting channel/ frequency: TX = 824.2 MHz							
Sweep frequency range: [MHz]	Diagram numbers	Remarkable highest peak found at [MHz]	Transducer	Margin to limit [dB]	Result [dBm]	Limit [dBm]	Verdict
Sweep 1	14.01	0.0343	--	--	-53.04	-13	Passed
Sweep 2	14.04	1648.0	--	--	-36.30		Passed ^{1.)}
Sweep 3	14.07b	--	--	>13	--		Passed ^{2.)}

Remark: see diagrams in annex 1 for more details

- 1.) Uplink TCH carrier on diagram
- 2.) Band-Block Edge (Block B') compliance performed with Average detector

Middle channel = 192

Transmitting channel/ frequency: TX = 837 MHz							
Sweep frequency range: [MHz]	Diagram numbers	Remarkable highest peak found at [MHz]	Transducer	Margin to limit [dB]	Result [dBm]	Limit [dBm]	Verdict
Sweep 1	14.02	0.0351	--	--	-52.19	-13	Passed
Sweep 2	14.05	3579.7	--	--	-33.21		Passed ^{1.)}

Remark: see diagrams in annex 1 for more details

- 1.) BCCH and Downlink TCH carrier on diagram

Highest channel: 251

Transmitting channel/ frequency: TX = 848.8 MHz							
Sweep frequency range: [MHz]	Diagram numbers	Remarkable highest peak found at [MHz]	Transducer	Margin to limit [dB]	Result [dBm]	Limit [dBm]	Verdict
Sweep 1	14.03	0.0351	--	--	-53.04	-13	Passed
Sweep 2	14.06	3585.5	--	--	-32.44		Passed ^{1.)}
Sweep 4	14.08b	--	--	>13	--		Passed ^{2.)}

Remark: see diagrams in annex 1 for more details

- 1.) Uplink TCH carrier on diagram
- 2.) Band-Edge Block (Block B') compliance performed with Average detector

5.4.0.2. GSM 1900 Mode: Op. Mode 2, Set-up 3

Lowest channel: 512

Transmitting channel/ frequency: TX = 1850,2 MHz							
Sweep frequency range: [MHz]	Diagram numbers	Remarkable highest peak found at [MHz]	Transducer	Margin to limit [dB]	Result [dBm]	Limit [dBm]	Verdict
Sweep 1	14.09	0.0351	--	--	-52.98	-13	Passed
Sweep 2	14.12	3588	--	--	-32.92		Passed ^{1.)}
Sweep 3	14.15b	--	--	>17	--		Passed ^{2.)}

Remark: see diagrams in Annex 1 for more details

- 1.) Uplink TCH carrier on diagram
- 2.) Band-Edge Block (Block A) compliance performed with Average detector

Middle channel: 661

Transmitting channel/ frequency: TX = 1880,0 MHz							
Sweep frequency range: [MHz]	Diagram numbers	Remarkable highest peak found at [MHz]	Transducer	Margin to limit [dB]	Result [dBm]	Limit [dBm]	Verdict
Sweep 1	14.10	0.0351	--	--	-51.94	-13	Passed
Sweep 2	14.13	2470.6	--	--	-31.96		Passed ^{1.)}

Remark: see diagrams in Annex 1 for more details

- 1.) Uplink TCH carrier on diagram

Highest channel: 810

Transmitting channel/ frequency: TX = 1908,8 MHz							
Sweep frequency range: [MHz]	Diagram numbers	Remarkable highest peak found at [MHz]	Transducer	Margin to limit [dB]	Result [dBm]	Limit [dBm]	Verdict
Sweep 1	14.11	0.0343	--	--	-51.40	-13	Passed
Sweep 2	14.14	2428.0	--	--	-32.93		Passed ^{1.)}
Sweep 3	14.16b	--	--	>15	--		Passed ^{2.)}

Remark: see diagrams in Annex 1 for more details

- 1.) Uplink TCH carrier on diagram
- 2.) Band-Edge Block (Block C) compliance performed with Average detector

RESULTS (RADIATED)

5.4.0.2.1. GSM 850 Mode: Set-up 1, Op. Mode 1

Lowest channel: 128

Transmitting channel/ frequency: TX = 824.2 MHz							
Sweep frequency range: [MHz]	Diagram numbers	Remarkable highest peak found at [MHz]	Worst-Antenna Polarisation	Transducer	Result [dBm]	Limit [dBm]	Verdict
Sweep 1	8.29/8.30	--	H/V	--	<-28.0	-13	Passed ^{1.)+2.)}
Sweep 2	8.35/8.36	823.98	V	--	<-20.0		Passed ^{3.)}
Sweep 4	8.39/8.40	--	V	--	<-21.5		Passed ^{1.)}
Sweep 5	8.45/8.46	--	H/V	--	<-29.0		Passed ^{1.)}

Remarks: see diagrams enclosed in annex A1, only worst-case polarisation mentioned

- 1.) only results near 20dB to the limit are referenced or noise level
- 2.) TX-carrier on the diagram
- 3.) Band-Edge compliance

Middle channel: 192

Transmitting channel/ frequency: TX = 837 MHz							
Sweep frequency range: [MHz]	Diagram numbers	Remarkable highest peak found at [MHz]	Worst-Antenna Polarisation	Transducer	Result [dBm]	Limit [dBm]	Verdict
Sweep 1	8.31/8.32	--	V	--	<-28.0	-13	Passed ^{1.)+2.)}
Sweep 4	8.41/8.42	2489.7	H	--	-22.03		Passed ^{1.)}
Sweep 5	8.47/ 8.48	--	H/V	--	<-29.0		Passed ^{1.)}

Remarks: see diagrams enclosed in annex A1, only worst-case polarisation mentioned

- 1.) only results near 20dB to the limit are referenced or noise level
- 2.) TX-carrier on the diagram

Highest channel: 251

Transmitting channel/ frequency: TX = 849.8 MHz							
Sweep frequency range: [MHz]	Diagram numbers	Remarkable highest peak found at [MHz]	Worst-Antenna Polarisation	Transducer	Result [dBm]	Limit [dBm]	Verdict
Sweep 1	8.33/8.34	620.94	H	--	-32.31	-13	Passed ^{1.)+2.)}
Sweep 3	8.37/8.38	--	V	--	<-18.5		Passed ^{3.)}
Sweep 4	8.43/8.44	--	H/V	--	<-20.5		Passed ^{1.)}
Sweep 5	8.49/8.50	--	H/V	--	<-29		Passed

Remarks: see diagrams enclosed in annex A1, only worst-case polarisation mentioned

- 1.) only results near 20dB to the limit are referenced or noise level
- 2.) TX-carrier on the diagram
- 3.) Band-Edge compliance

5.4.0.3. GSM 1900 Mode: Set-up 1, Op. Mode 2

Lowest channel: 512

Transmitting channel/ frequency: TX = 1850,2 MHz							
Sweep frequency range: [MHz]	Diagram numbers	Remarkable highest peak found at [MHz]	Worst-Antenna Polarisation	Transducer factor [dB]	Result [dBm]	Limit [dBm]	Verdict
Sweep 1	8.01/8.02	--	H/V	--	<-31.0	-13	Passed ^{1.)}
Sweep 2 ^{2.)}	8.03/8.04	--	H/V	--	<-20.0		Passed ^{1.)+2.)}
Sweep 3 ^{4.)}	8.05/8.06	1850.0	V	--	-32.11		Passed ^{4.)}
Sweep 5	8.07/8.08	5547/5546	H/V	--	-37.89		Passed
Sweep 6	8.09/8.10	14910	H	--	-23.91		Passed
Sweep 7 ^{5.)}	8.51	--	--	--	<-25.0		Passed ^{5.)}

Remark: see diagrams in annex 1 for more details, only worst-case polarisation mentioned

- 1.) only results near 20dB to the limit are referenced or noise level
- 2.) TX-carrier on diagram
- 4.) Band-Edge compliance
- 5.) overview measurement only

Middle channel: 661

Transmitting channel/ frequency: TX = 1880,0 MHz							
Sweep frequency range: [MHz]	Diagram numbers	Remarkable highest peak found at [MHz]	Worst-Antenna Polarisation	Transducer factor [dB]	Result [dBm]	Limit [dBm]	Verdict
Sweep 1	8.11/8.12	--	H/V	--	<-30.0	-13	Passed ^{1.)}
Sweep 2	8.13/8.14	--	H/V	--	<-20.0		Passed ^{1.)+2.)}
Sweep 5	8.15/8.16	5639	V	--	-37.29		Passed
Sweep 6	8.17/8.18	17890	V	--	-21.81		Passed
Sweep 7	8.52	--	--	--	<-25.0		Passed ^{5.)}

Remark: see diagrams in annex 1 for more details, only worst-case polarisation mentioned

- 1.) only results near 20dB to the limit are referenced or noise level
- 2.) TX-carrier on diagram
- 5.) overview measurement only

Highest channel: 810

Transmitting channel/ frequency: TX = 1908,8 MHz							
Sweep frequency range: [MHz]	Diagram numbers	Remarkable highest peak found at [MHz]	Worst-Antenna Polarisation	Transducer factor [dB]	Result [dBm]	Limit [dBm]	Verdict
Sweep 1	8.19/8.20	--	H/V	--	< -30.0	-13	Passed ^{1.)}
Sweep 2	8.21/8.22	--	H/V	--	<-20.0		Passed ^{1.)+2.)}
Sweep 4	8.23/8.24	1910.0	V	--	-32.18		Passed ^{4.)}
Sweep 5	8.25/8.26	5731.5	V	--	-37.59		Passed
Sweep 6	8.27/8.28	17120	V	--	-23.24		Passed
Sweep 7	8.53	--	--	--	<-25.0		Passed ^{5.)}

Remark: see diagrams in annex 1 for more details, only worst-case polarisation mentioned

- 1.) only results near 20dB to the limit are referenced or noise level
- 2.) TX-carrier on diagram
- 4.) Band-Edge compliance
- 5.) overview measurement only

AMBIENT ENVIRONMENTAL CONDITIONS

Temperature	18.1 °C
Relative Humidity	44 %
Air pressure	1001 hPa

TEST EQUIPMENT

Used equipment at FAR system [ref. no. 443] (see reference in the annex)
549, 087, 264 , 439

5.5. Frequency stability on temperature and voltage variations

REFERENCES

FCC: §2.1055, §22.355, §24.235

IC: RSS-Gen:4.7, RSS-132:4.3, RSS-133:4.2+6.3

§22.355 Table C-1; § 24.235

“The frequency stability shall be sufficient to ensure that the fundamental emission stays within the authorized frequency block”

§ 2.1055

(d) The frequency stability shall be measured with variation of primary supply voltage as follows:

(1) Vary primary supply voltage from 85 to 115 percent of the nominal value for other than hand carried battery equipment.

(2) For hand carried, battery powered equipment, reduce primary supply voltage to the battery operating end point which shall be specified by the manufacturer.

TEST SET-UP

In order to maintain the voltage constant over the time period of the tests, a dummy battery was connected to a laboratory power supply. The power supply voltage was controlled on the input of the power supply terminals of the EUT.

Compare with the conducted measurement test set-up described in chapter 4.1

MOBILE PHONE SETTINGS

- The measurements were made at the upper, middle, and lower carrier frequencies of the operating band. Choosing three representative TX-carrier frequencies of the mobile phone within each operable GSM band, should be sufficient to demonstrate compliance.
- Settings on base station and mobile phone were made according chapter 3.7

TEST METHOD

The RF Channel spacing is 200kHz, with a guard band of 200kHz of each band of the sub-bands. The aim of the EUT is to function under all extreme conditions within authorized sub-bands in regard to temperature and voltage variations. The frequency deviation was recorded with base station's built in capability. (CMU) As the standard requires that the fundamental emissions stays within the authorized band, a limit of 0.1ppm is considered low enough to ensure this.

Frequency shift of carrier against a voltage range at constant nominal temperature of 20° Celsius

- 1.) determine the carrier frequency for the lowest and highest channel at room temperature and nominal voltage [20°C]
- 2.) The voltage was reduced in 0.1V steps to the lower end point, where the mobile phone stops working. (this shall be specified by the manufacturer) Record the carrier frequency shift within 2 minutes after powering on the mobile phone, to prevent for self heating effects.
- 3.) The voltage was increased in 0.1V steps to the upper declared voltage of the battery. Record the carrier frequency shift within 2 minutes after powering on the mobile phone, to prevent for self heating effects.

RESULTS

5.5.0.1. GSM 850 Mode: Op. Mode 1, set-up 3

Voltage	Channel 128	Channel 192	Channel 251	Channel 128	Channel 192	Channel 251
	[Hz]			ppm		
3,32=Minimum	-22	-21	-28	-0,027	-0,025	-0,033
3,4	-24	-22	-23	-0,029	-0,026	-0,027
3,5	-20	-19	-18	-0,024	-0,023	-0,021
3,6	-23	-19	-26	-0,028	-0,023	-0,031
3,7	-26	-28	-18	-0,032	-0,033	-0,021
3,8	-25	-23	-25	-0,030	-0,027	-0,029
3,9	-25	-25	-25	-0,030	-0,030	-0,029
4,0	-25	-22	-26	-0,030	-0,026	-0,031
4,1	-22	-20	-24	-0,027	-0,024	-0,028
4,2	-25	-24	-23	-0,030	-0,029	-0,027
4,3	-25	-25	-25	-0,030	-0,030	-0,029
4,4	-23	-22	-26	-0,028	-0,026	-0,031
4,5=Maximum	-22	-22	-27	-0,027	-0,026	-0,032

Remark: -.

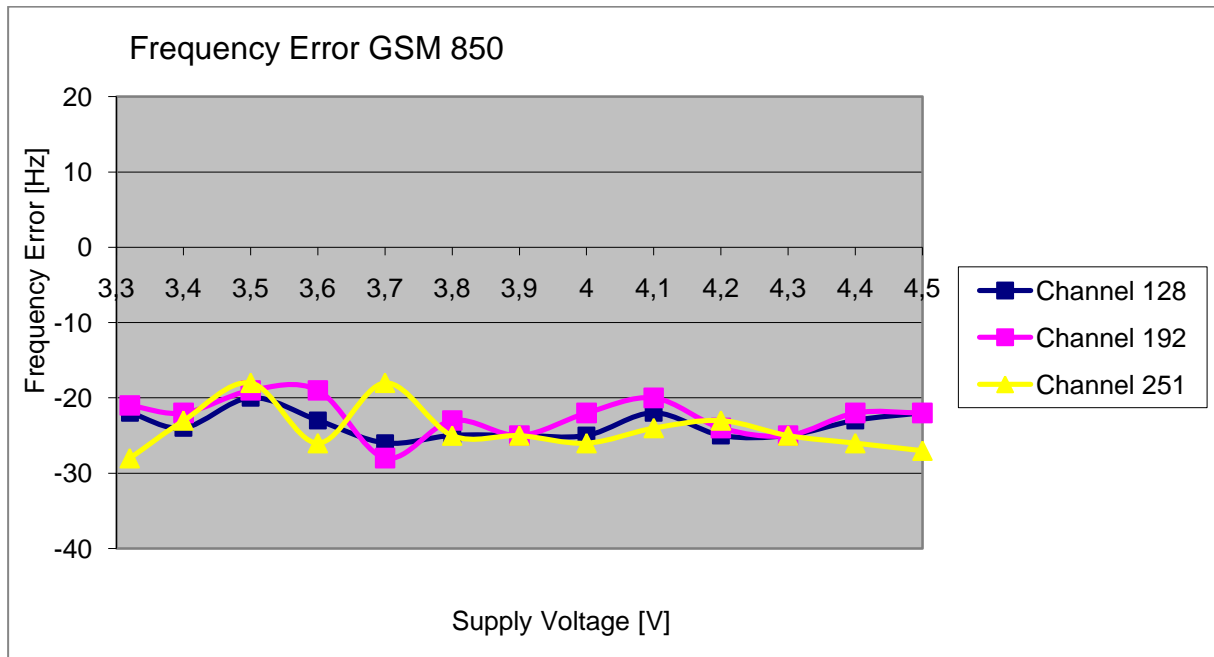

5.5.0.2. GSM 1900 Mode: Op. Mode 2, Set-up 3

Voltage	Channel 512	Channel 661	Channel 810	Channel 512	Channel 661	Channel 810
	[Hz]			[ppm]		
3,32=Minimum	42	50	46	0,023	0,027	0,024
3,4	45	48	41	0,024	0,026	0,021
3,5	51	51	45	0,028	0,027	0,024
3,6	39	42	48	0,021	0,022	0,025
3,7	43	44	51	0,023	0,023	0,027
3,8	-33	-34	-32	-0,018	-0,018	-0,017
3,9	35	36	40	0,019	0,019	0,021
4,0	-36	-33	47	-0,019	-0,018	0,025
4,1	29	46	45	0,016	0,024	0,024
4,2	37	43	40	0,020	0,023	0,021
4,3	40	40	53	0,022	0,021	0,028
4,4	35	41	38	0,019	0,022	0,020
4,5=Maximum	45	49	40	0,024	0,026	0,021

Remark: --

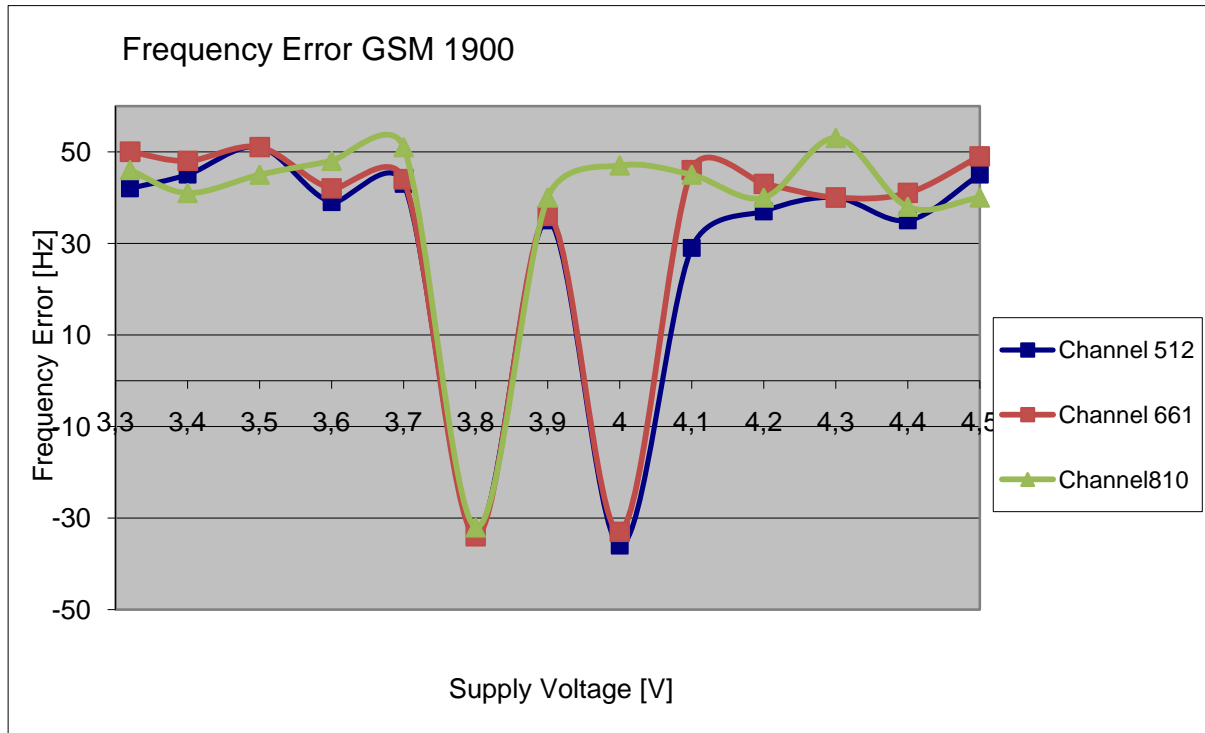

Frequency shift of carrier against temperature at constant power supply voltage

- 1.) determine the carrier frequency for the lowest, middle and highest channel at room temperature and nominal voltage [20°C]
- 2.) expose the mobile station to -30°C, wait sufficient time to have constant temperature.
- 3.) Perform the carrier frequencies measurements in 10°C increments from -30°C to +50°C. For about half hour at the specified temperature the mobile was powered-off. After powering-on, the measurements were made within 2 minute for the channel lower channel, in order to prevent self-warming of the mobile.

RESULTS

5.5.0.3. GSM850 Mode: Op. Mode 1, set-up 3

Temperature	Channel 128	Channel 192	Channel 251	Channel 128	Channel 192	Channel 251
	[Hz]			[ppm]		
-30	-21	-28	-26	-0,025	-0,033	-0,031
-20	-22	-26	-23	-0,027	-0,031	-0,027
-10	-26	-26	-23	-0,032	-0,031	-0,027
0	-20	-36	-25	-0,024	-0,043	-0,029
10	-24	-25	-26	-0,029	-0,030	-0,031
20	-22	-22	-27	-0,027	-0,026	-0,032
30	-25	-25	-27	-0,030	-0,030	-0,032
40	-25	-28	-25	-0,030	-0,033	-0,029
50	-26	-27	-23	-0,032	-0,032	-0,027

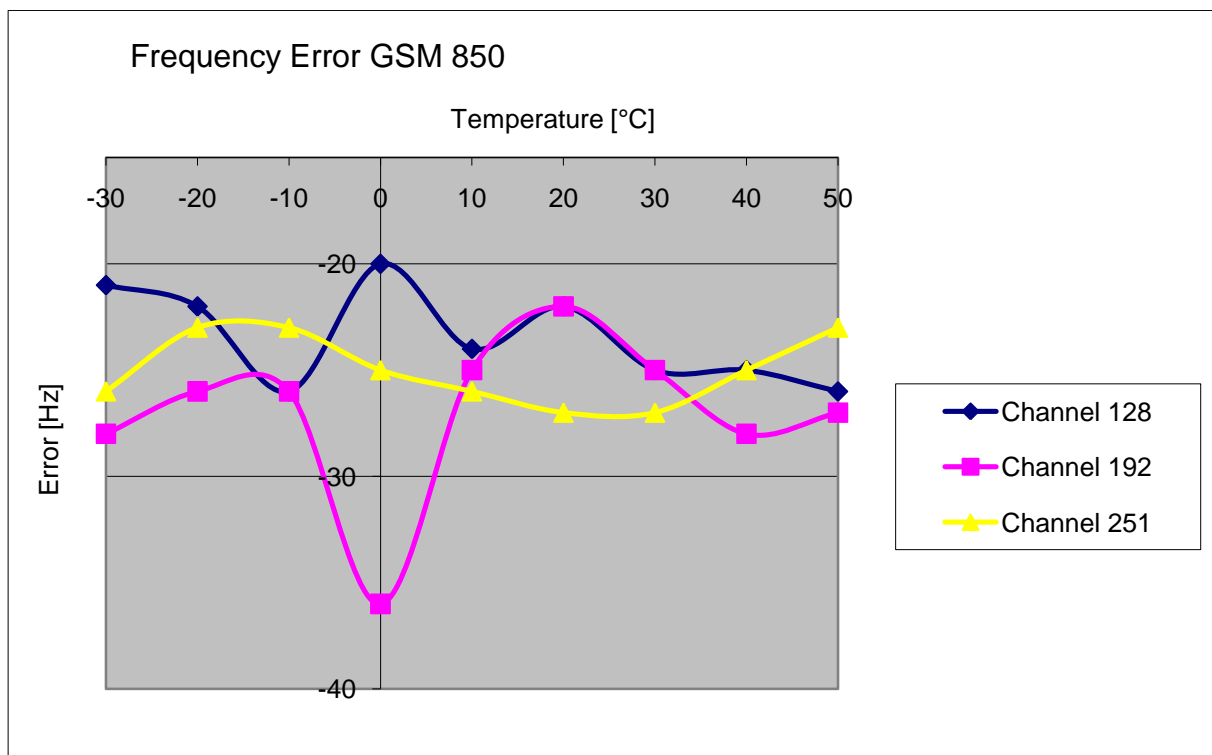

5.5.0.4. GSM 1900 Mode: Op. Mode 2, set-up 3

Temperature	CHANNEL 512	CHANNEL 661	CHANNEL 810	CHANNEL 512	CHANNEL 661	CHANNEL 810
	[Hz]			[ppm]		
-30	42	51	44	0,023	0,027	0,023
-20	35	45	43	0,019	0,024	0,023
-10	42	53	56	0,023	0,028	0,029
0	48	50	53	0,026	0,027	0,028
10	41	42	42	0,022	0,022	0,022
20	45	49	40	0,024	0,026	0,021
30	38	40	41	0,021	0,021	0,021
40	41	36	34	0,022	0,019	0,018
50	35	-35	45	0,019	-0,019	0,024

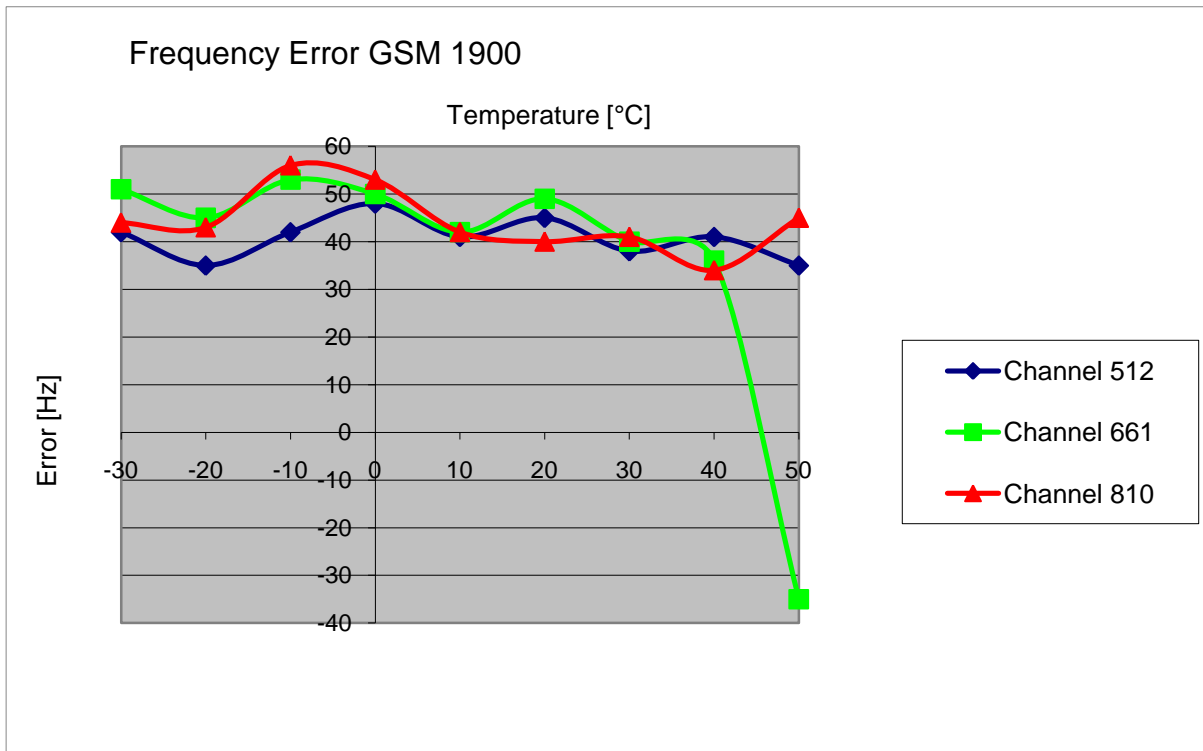

TEST EQUIPMENT

Used equipment at Radio Laboratory [ref. no. 347] (see reference in the annex)
298 (R&S CMU200)
354 (PS NGPE40/40)
468 (FLUKE 112 MM)
517 (RF-Relay Unit Keithley)
529 (6dB RF-Splitter)
530 (10dB Attenuator)
405 (OPUS Thermo/Hygrometer used for climatic chamber VT4002)

5.6. Conducted emissions on AC-Power lines

Test location and equipment (for reference numbers please see chapter 'List of test equipment')

test location	<input checked="" type="checkbox"/> CETECOM Essen (Chapter 2.2.1)	<input type="checkbox"/> Please see Chapter 2.2.2	<input type="checkbox"/> Please see Chapter 2.2.3
test site	<input type="checkbox"/> 333 EMI field	<input checked="" type="checkbox"/> 377 ESCS 30	<input type="checkbox"/> 334 EMS-field
receiver	<input type="checkbox"/> 001 ESS	<input type="checkbox"/> 377 ESCS 30	<input type="checkbox"/> 005
LISN	<input checked="" type="checkbox"/> 005 ESH2-Z5	<input type="checkbox"/> 007 ESH3-Z6	<input type="checkbox"/> 300 ESH3-Z5 & 50Ω used for AE
signaling	<input type="checkbox"/> 017 CMD 65	<input type="checkbox"/> 323 CMD 55	<input type="checkbox"/> 340 CMD 55
signaling	<input type="checkbox"/> 298 CMU	<input type="checkbox"/> 460 CMU	<input checked="" type="checkbox"/> 295 RACAL
			<input checked="" type="checkbox"/> 392 MT8820A

Standards and Limits: Part 15, Subpart C, §15.207, CANADA: RSS-Gen:7.2.2, ANSI C63.4:2009

Frequency [MHz]	Conducted limit [dBμV]	
	QUASI-Peak	AVERAGE
0.15 – 0.5	66 to 56*	56 to 46*
0.5 – 5	56	46
5 – 30	60	50

Remark: * decreases with the logarithm of the frequency

Test condition and measurement procedures test set-up

link to test system (if used):	<input checked="" type="checkbox"/> air link	<input type="checkbox"/> cable connection	<input type="checkbox"/>
EUT-grounding	<input checked="" type="checkbox"/> none	<input type="checkbox"/> with power supply	<input type="checkbox"/> additional connection
Equipment set up	<input checked="" type="checkbox"/> table-top (40 cm distance to reference ground plane (wall))	<input type="checkbox"/> floor-standing	EUT stands isolated on reference ground plane (floor)
Climatic conditions	Temperature: (23°C)	Rel. humidity: (77)%	
EMI-Receiver (Analyzer) Settings	Span/Range: 150 kHz to 30 MHz RBW: 9 kHz Detector/Mode: Max PEAK-hold, repetitive scan for preliminary testing Quasi-Peak Detector and Average-Detector for final measurement according ANSI 63.4, CISPR 16		

Devices which can be connected to the public AC-power network, should be tested against the radio frequency voltage conducted back into the AC-power line in the frequency range 150kHz to 30 MHz. Compliance should be tested by measuring the radio frequency voltage between each power line and ground at the power terminals in the stated frequency range.

A 50Ω/50μH line impedance stabilization network (LISN) is used therefore. The EUT power input leads are connected through the LISN to the AC-power source. The LISN enclosure is electrically connected to the GND-plane. The measuring instrument is connected to the coaxial output of the LISN.

Tabletop devices were set-up on a 80 cm height over reference ground plane, floor standing equipment 10 cm raised above ground plane.

Measurements have been performed on each phase line and neutral line of the devices AC-power lines. The EUT was power supplied with 110 V/60Hz.

The EUT was tested in the defined operating mode and installed (connected) to accessory equipment according the general description of use given by the applicant.

Preliminary testing as a first step, determines the worst-case phase line (neutral or phase) as well as the most critical amplitude by changing the operating mode. A complete frequency-sweep is performed with PK-Detector.

Final testing for power phases and critical frequencies (Margin to AV- or QP limit lower than 3dB) as a second step includes measurements either on discrete frequency components with receivers detector set to Quasi-Peak and Average per frequency component or a complete sweep with corresponding detector.

Measurement results

For showing compliance with conducted limits a commercial available AC/DC adapter (AE2) was chosen for delivering the required 9 V DC to the DSB75 board (EUT E).

EUT Type and S/N or EUT set-up no.		4			
Diagram No.	Command or EUT operating mode or operating mode no.	Detector (Peak, CISPR AV, CISPR QP)	Power line (L1, L2, L3, N)	Additional (scan-) information (e.g. Pre-test Fast scan, Maxhold, Final measurement)	Result (passed / failed /final measurement . necessary)
1.4	EUT operating mode 1	Peak, AV, QP	L1, N	The Diagram shows PK/AV detector measurements on L1 and N with max-hold mode. Final measurement QP and AV was carried out on at least one frequency	passed
1.2	EUT operating mode 2	Peak, AV, QP	L1, N	The Diagram shows PK/AV detector measurements on L1 and N with max-hold mode. Final measurement QP and AV was carried out on at least one frequency	passed

Remarks: pls. see annex 1 for detailed diagrams

Margin to Limit for verdict: $M = L_T - R_R + C_{Loss}$

Abbreviations used:

- R_R : Receiver readings in dB μ V
- C_{Loss} : cable loss
- L_T : Limit in dB μ V

Verdict

Summary of measurement results for conducted emissions on AC-Power lines: Passed

Additionally test equipment

Used equipment (see reference in the annex)
016 (Spitzenberger Spies 110V&60Hz)
468 (FLUKE 112 MM)

6. Calibration method of anechoic chamber

For non-critical frequencies a pre-calibration method was used for determining the relevant radiated field-strength of radiated spurious in the anechoic chamber.

Generally the measured value is influenced by the characteristics of the used cables, filters, antenna, but also by the characteristic of the anechoic chamber.

By defining a *transducer* value, which include all characteristics of the signal propagation path (used equipment, cables, properties of anechoic chamber, etc..) from the source of radiation to the final reading equipment (spectrum-analyzer), the measured value can be corrected in order to get the real value of the device under test.

The method resumes as follows:

- 1.) determination of the path-loss of all cables used on the TX- and RX-side, which are used for the radiated measurement in the specific set-up for 1 meter and 3 meter distance.
- 2.) connection of the cables to the relevant antennas used for calibration.
- 3.) determination of the *space attenuation loss* (*G*) in the anechoic-chamber for both horizontal and vertical antenna polarisations:

A signal generator connected to the TX-antenna sweeps the frequency range of interest (30 MHz to 19.5 GHz) with a level of -30dBm - the readings on the RX-side on the spectrum analyzer gives the *space attenuation loss*. The distance between RX- and TX-antenna is 3 meter for frequencies below 18 GHz, and 1 meter for frequencies above 18 GHz.

- 4.) Mathematical determination of the frequency dependant transducer values ($TD_{H/V}$):

$$TD_{H/V} = G_{H/V} + B_{H/V} - 10 \cdot \log_{10}(1,64) + D + E - F$$

Abbreviations:

$TD_{H/V} = \lambda/2$ transducer values for horizontal /vertical antenna polarisations

$G_{H/V}$ = space attenuation loss horizontal/ vertical

$B_{H/V}$ = Gain of TX-antenna

$$10 * \log_{10}(1.64) = \text{Gain in dB of } \lambda/2 \text{ Dipole relative to isotropic radiator}$$

D = insertion losses of RX cable

E = Loss of filters in signal path (not used for FCC measurements)

F = Gain of pre-amplifiers in signal path

- 5.) The transducer values are recorded for horizontal and vertical polarisations in two reference distances to the measurement antenna (1 meter and 3 meter). EIRP can be calculated from ERP by adding the gain of the lambda/2 dipole $EIRP = ERP + 2.14 \text{ dBi}$
- 6.) The specific transducer tables are loaded in the spectrum analyzer after each measurement. The readings on the spectrum-analyzer are automatically corrected by this values and can directly be compared with the limits as given in the relevant standards. The loaded values are displayed in each diagram and can be compared to internal calibration documents annually performed.

Used equipment for calibration (3 meter distance)

Used equipment (see reference)
264, 549, 020, 140, 484, 439,

Used equipment for calibration (1 meter distance)

Used equipment (see reference)
302, 303, 140, 264

7. Measurement uncertainties

The reported uncertainties are calculated based on the standard uncertainty multiplied with the appropriate coverage factor **k**, such that a confidence level of approximately 95% is achieved.

For uncertainty determination, each component used in the concrete measurement set-up was taken in account and it's contribution to the overall uncertainty according it's statistical distribution calculated.

Following table shows expectable uncertainties for each measurement type performed.

Measurement	Frequency range	Calculated uncertainty based on a confidence level of 95%	Remarks:
RF-Power Output conducted	9 kHz .. 20 GHz	1.0 dB	--
RF-Power Output radiated	30 MHz .. 4 GHz	3.17 dB	Substitution method
Conducted RF-emissions on antenna ports	9 kHz .. 20 GHz	1.0 dB	--
Radiated RF-emissions enclosure	150 kHz .. 30 MHz	5.0 dB	Magnetic field
	30 MHz .. 1 GHz	4.2 dB	E-Field
	1 GHz .. 18GHz	4.8 dB	E-Field
	1 GHz .. 20 GHz	3.17 dB	Substitution method
Occupied bandwidth	9 kHz .. 4 GHz	0.1272 ppm (Delta Marker method)	Frequency error
		1 dB	Power
Emission bandwidth	9 kHz .. 4 GHz	0.1272 ppm (Delta Marker method)	Frequency error
		1 dB	Power
Frequency stability	9 kHz .. 20 GHz	0.0636 ppm	--
Conducted emissions on AC-mains port (U _{CISPR})	9 kHz .. 150 kHz	4.0 dB	--
	150 kHz .. 30 MHz	3.6 dB	

Table : measurement uncertainties, valid for conducted/radiated measurements

8. Instruments and Ancillary

8.1. Used equipment “CTC”

The “Ref.-No” in the left column of the following tables allows the clear identification of the laboratory equipment.

8.1.1. Test software and firmware of equipment

Ref.-No.	Equipment	Type	Serial-No.	Version of Firmware or Software during the test
001	emi test receiver	ESS	825132/017	Firm.= 1.21 , OTP=2.0, GRA=2.0
012	signal generator (EMS-cond.)	SMY 01	839069/027	Firm.= V 2.02
013	power meter (EMS cond.)	NRVD	839111/003	Firm.= V 1.51
017	Communication Tester	CMD 60 M	844365/014	Firmware = V 3.52 .22.01.99, DECT Firmware D2.87
053	audio analyzer	UPA3	860612/022	Firm. V 4.3
119	RT harmonics analyser/dig. flickermeter	B10	G60547	Firm.= V 3.1DHG
140	signal generator	SMHU	831314/006	Firm.= 3.21
261	thermal power sensor	NRV-Z55	825083/0008	EPROM-Datum 02.12.04, SE EE 1 B
262	power meter	NRV-S	825770/0010	Firm.= 2.6
263	signal generator	SMP 04	826190/0007	Firm.=3.21
264	spectrum analyzer	FSEK 30	826939/005	Bios=2.1, Analyzer= 3.20
295	Racal Digital Radio Test Set	6103	1572	UNIT Firmware= 4.04, SW-Main=4.04, SW-BBP=1.04,
298	Univ. Radio Communication Tester	CMU 200	832221/091	R&S Test Firmware =3.53 /3.54 (current Testsoftw. f.
323	Communication Tester	CMD 055	825878/0034	Firm.= 3.52 .22.01.99
331	climatic test chamber -40/+80 Grad	HC 4055	43146	TSI 1.53
335	System-CTC-EMS-Conducted	System EMS Conducted	-	EMS-K1 Immunity Test-Software 1.20SR10
340	Univ. Communication Tester	CMD 55	849709/037	Firm.= 3.52 .22.01.99
355	power meter	URV 5	891310/027	Firm.= 1.31
365	10V Insertion Unit 50 Ohm	URV5-Z2	100880	Eprom Data = 31.03.08
366	Ultra Compact Simulator	UCS 500 M4	V0531100594	Firm. UCS 500=001925/3.06a02, rc=ISMIEC 4.10
371	Bluetooth Tester	CBT32	100153	CBT V4.6.1 + SW-Option K55
377	emi test receiver	ESCS 30	100160	Firm.= 2.30, OTP= 02.01, GRA= 02.36
378	broadband RF field monitor	RadiSense III	03D00013SNO-08	Firm.= V.03D13
383	signal generator	SME 03	842 828 /034	Firm.= 4.61
389	digital multimeter	Keithley 2000	0583926	Firm. = A13 (Mainboard) A02 (Display)
392	Radio Communication Tester	MT8820A	6K00000788	Firm.= 4.50 #005, IPL=4.01#001,OS=4.02#001,
441	System CTC-SAR-EMI Cable Loss	System EMI field (SAR)	-	EMC 32 Version 8.10.10
442	System CTC-SAR-EMS	System EMS field (SAR)	-	EMS-K1 Immunity-Software 1.20SR10
443	System CTC-FAR-EMI-Spuri	System CTC-FAR-EMI-	-	Spuri 7.2.5
444	System CTC FAR-EMS	System EMS-Field (FAR)	-	EMS-K1 Immunity-Software 1.20SR10
460	Univ. Radio Communication Tester	CMU 200	108901	R&S Test Firmware Base=5.14/Messsoftware=
489	emi test receiver	ESU40	1000-30	Firmware=4.43 SP3, Bios=V5.1-16-3,
491	ESD Simulator dito	ESD dito	dito307022	V 2.30
524	Voltage Drop Simulator	VDS 200	0196-16	Software Nr: 000037 Version V4.20a01
526	Burst Generator	EFT 200 A	0496-06	Software Nr. 000034 Version V2.32
527	Micro Pulse Generator	MPG 200 B	0496-05	Software-Nr. 000030 Version V2.43
528	Load Dump Simulator	LD 200B	0496-06	Software-Nr. 000031 Version V2.35a01
547	Univ. Radio Kommunikation Tester	CMU 200	835390/014	R&S Test Firmware Base=V5.1403 (current Testsoftw.
584	Spectrum Analyzer	FSU 8	100248	2.82 SP3
594	Communication Tester	CMW500	101757	Firmware and Applications 1.0.15.23
597	Univ. Radio Communication Tester	CMU 200	100347	R&S Test Firmware Base=5.01 /Messsoftware=
598	Spectrum Analyser	FSEM 30	831259/013	Firmware Bios 3.3 , Analyzer 3.3

8.1.2. Single instruments and test systems

Ref.-No.	Equipment	Type	Serial-No.	Manufacturer	Interval of calibration	Remark	Cal due
001	emi test receiver	ESS	825132/017	Rohde & Schwarz	12 M	-	31.03.2011
005	AC - LISN (50 Ohm/50µH, test site 1)	ESH2-Z5	861741/005	Rohde & Schwarz	24 M	-	31.03.2012
007	DC - LISN (50 Ohm/5µH)	ESH3-Z6	892563/002	Rohde & Schwarz	24 M	-	31.03.2012
009	power meter (EMS-radiated)	NRV	863056/017	Rohde & Schwarz	12 M	-	31.03.2011
011	insertion unit (EMS-radiated)	URV5-Z2	864169/004	Rohde & Schwarz	24 M	-	31.03.2011
012	signal generator (EMS-cond.)	SMY 01	839069/027	Rohde & Schwarz	36/12 M	-	31.03.2011
013	power meter (EMS cond.)	NRVD	839111/003	Rohde & Schwarz	24 M	-	31.03.2011
014	insertion unit (EMS cond.)	URV5-Z2	838519/029	Rohde & Schwarz	24 M	-	31.03.2011
015	insertion unit (EMS cond.)	URV5-Z4	838570/024	Rohde & Schwarz	24 M	-	31.03.2011
016	line impedance simulating network	Op. 24-D	B6366	Spitzenberger+Spies	36 M	-	31.03.2013
017	Communication Tester	CMD 60 M	844365/014	Rohde & Schwarz	12 M	-	31.03.2011
020	horn antenna 18 GHz (Subst 1)	3115	9107-3699	EMCO	36/12 M	-	31.03.2013
021	loop antenna (H-Field)	6502	9206-2770	EMCO	36 M	-	31.03.2013
022	audio measurement amplifier	2636C	1537643	Brüel & Kjaer	12 M	-	31.03.2011
030	loop antenna (H-field)	HFH-Z2	879604/026	Rohde & Schwarz	36 M	-	31.03.2012
031	absorbing clamp	MDS-21	863325/015	Rohde & Schwarz	24 M	-	31.03.2012
033	RF-current probe (100kHz-30MHz)	ESH2-Z1	879581/18	Rohde & Schwarz	24 M	-	31.03.2011
049	current clamp (injection)	F-120-2	48	FCC	12 M	-	31.03.2011
050	3-ph coupling-decoupling-netw. (Burst)	CDN 300	176	Schaffner	24 M	-	31.03.2012
051	VHF-current probe 20-300 MHz	ESV-Z1	872421	Rohde & Schwarz	36 M	-	31.03.2012
052	notch filter DECT	WRCB 1887,82/1889,55SS	12	Wainwright Industries	pre-m	-	30.05.2011
053	audio analyzer	UPA3	860612/022	Rohde & Schwarz	36 M	-	31.03.2011
057	relay-switch-unit (EMS system)	RSU	494440/002	Rohde & Schwarz	-	1a	30.05.2011
058	capacitive clamp (Burst)	IP 4	99	Hafely	-	4	-
060	power amplifier (DC-2kHz)	PAS 5000	B6363	Spitzenberger+Spies	-	3	-
066	notch filter (WCDMA; FDD1)	WRCT 1900/2200-5/40-	5	Wainwright GmbH	12 M	-	30.05.2011
067	coupling decoupling-network	CDN801-M2/M3	272	Lüthi	12 M	-	31.03.2011
068	coupling decoupling-network	CDN 801-M5	95226	Lüthi	12 M	-	31.03.2011
069	EM - clamp	EM101	9535159	Lüthi	36 M	-	31.03.2013
072	coupling decoupling-network	CDN801-M2/M3	276	Lüthi	12 M	-	31.03.2011
083	AC - power supply, 0-10 A	EAC/MT 27010	910502096	EURO TEST	pre-m	2	-
084	AC - power supply, 0-5 A	ELABO-8-34214	-	ELABO	pre-m	2	-
085	AC - power supply, 0-10 A	R250	-	Schunterm.&Benningh.	pre-m	2	-
086	DC - power supply, 0-10 A	LNG 50-10	-	Heinzinger Electronic	pre-m	2	-
087	DC - power supply, 0-5 A	EA-3013 S	-	Elektro Automatik	pre-m	2	-
090	Helmholtz coil: 2x10 coils in series	-	-	RWTÜV	pre-m	4	-
091	USB-LWL-Converter	OLS-1	007/2006	Ing. Büro Scheiba	-	4	-
094	artificial head (No.1)	4905	1566990	Brüel & Kjaer	pre-m	2	-
099	passive voltage probe	ESH2-Z3	299.7810.52	Rohde & Schwarz	36 M	-	31.03.2012
100	passive voltage probe	Probe TK 9416	without	Schwarzbeck	36 M	-	31.03.2012
110	USB-LWL-Converter	OLS-1	-	Extreme USB	-	4	-
119	RT harmonics analyser/dig. flickermeter	B10	G60547	BOCONSULT	36 M	-	31.03.2013
121	notch filter GSM 1900	WRCB 1879,5/1880,5EE	15	Wainwright GmbH	12 M	-	30.05.2011
122	notch filter GSM 1800	WRCB 1747/1748	12	Wainwright GmbH	12 M	-	30.05.2011
131	RF-Current Probe	F-52	19	FCC	12 M	-	31.03.2011
134	horn antenna 18 GHz (Subst 2)	3115	9005-3414	EMCO	12 M	-	31.03.2011
136	adjustable dipole antenna (Dipole 1)	3121C-DB4	9105-0697	EMCO	12 M	-	31.03.2012
140	signal generator	SMHU	831314/006	Rohde & Schwarz	24 M	-	31.03.2012
248	attenuator	SMA 6dB 2W	-	Radiall	pre-m	2	-
249	attenuator	SMA 10dB 10W	-	Radiall	pre-m	2	-
252	attenuator	N 6dB 12W	-	Radiall	pre-m	2	-
254	high pass GSM1800/1900/DECT	5HC 2600/12750-1,5KK	23042	Trilithic	12 M	-	30.05.2011
256	attenuator	SMA 3dB 2W	-	Radiall	pre-m	2	-
257	hybrid	4031C	00491	Narda	pre-m	2	-
260	hybrid coupler	4032C	11342	Narda	pre-m	2	-
261	thermal power sensor	NRV-Z55	825083/0008	Rohde & Schwarz	24/12 M	-	31.03.2012
262	power meter	NRV-S	825770/0010	Rohde & Schwarz	24 M	-	31.03.2012
263	signal generator	SMP 04	826190/0007	Rohde & Schwarz	36 M	-	31.03.2013
264	spectrum analyzer	FSEK 30	826939/005	Rohde & Schwarz	12 M	-	31.03.2011
265	peak power sensor	NRV-Z33, Model 04	840414/009	Rohde & Schwarz	24 M	-	31.03.2012
266	peak power sensor	NRV-Z31, Model 04	843383/016	Rohde & Schwarz	24 M	-	31.03.2012
268	AC/DC power supply	EA 3050-A	9823636	-	pre-m	2	-
270	termination	1418 N	BB6935	Weinschel	pre-m	2	-
271	termination	1418 N	BE6384	Weinschel	pre-m	2	-
272	attenuator (20 dB) 50 W	Model 47	BF6239	Weinschel	pre-m	2	-
273	attenuator, (10 dB) 100 W	Model 48	BF9229	Weinschel	pre-m	2	-
274	attenuator (10 dB) 50 W	Model 47 (10 dB) 50 W	BG0321	Weinschel	pre-m	2	-
275	DC-Block	Model 7003 (N)	C5129	Weinschel	pre-m	2	-
276	DC-Block	Model 7006 (SMA)	C7061	Weinschel	pre-m	2	-
279	power divider	1515 (SMA)	LH855	Weinschel	pre-m	2	-
284	coupling decoupling network	CDN 801-M1	1661	Lüthi	12 M	-	31.03.2011
285	coupling decoupling network	CDN 801-S1	1642	Lüthi	12 M	-	31.03.2011
287	pre-amplifier 25MHz - 4GHz	AMF-2D-100M4G-35-10P	379418	Miteq	12 M	-	30.05.2011
290	notch filter GSM 900	WRCA 901,9/903,1SS	3RR	Wainwright GmbH	12 M	-	30.05.2011
291	high pass filter GSM 850/900	WHJ 2200-4EE	14	Wainwright GmbH	12 M	-	30.05.2011
296	audio measurement amplifier	2636C	R=316568/004	Brüel & Kjaer	18 M	-	31.03.2011
298	Univ. Radio Communication Tester	CMU 200	832221/091	Rohde & Schwarz	12 M	-	31.03.2011
299	audio microphone	134	-	Brüel & Kjaer	pre-m	2	-
300	AC LISN (50 Ohm/50µH, 1-phase)	ESH3-Z5	892 239/020	Rohde & Schwarz	12 M	-	31.03.2011
301	attenuator (20 dB) 50W, 18GHz	47-20-33	AW0272	Lucas Weinschel	pre-m	2	-
302	horn antenna 40 GHz (Meas 1)	BBHA9170	155	Schwarzbeck	36 M	-	31.03.2011

Ref.-No.	Equipment	Type	Serial-No.	Manufacturer	Interval of calibration	Remark	Cal due
303	horn antenna 40 GHz (Subst 1)	BBHA9170	156	Schwarzbeck	36 M	-	31.03.2011
304	fix dipole antenna 1,6 GHz	EMCO 3125-307	9907-1001	ETS	24/12 M	-	31.03.2011
305	fix dipole antenna 1,8-2,0 GHz	EMCO 3125-306	9907-1001	ETS	24/12 M	-	31.03.2011
306	fix dipole antenna 2,45 GHz	EMCO 3125-308	9907-1001	ETS	24/12 M	-	31.03.2011
307	fix dipole antenna 3 GHz	EMCO 3125-309	9907-1001	ETS	24/12 M	-	31.03.2011
317	1000 Hz calibrator 94 dB SPL	4230 94dB	1542286	Brüel & Kjaer	12 M	-	31.03.2011
323	Communication Tester	CMD 055	825878/0034	Rohde & Schwarz	12 M	-	31.03.2011
331	climatic test chamber -40/+80 Grad	HC 4055	43146	Heraeus Vötsch	24 M	-	30.11.2012
335	System-CTC-EMS-Conducted	System EMS Conducted	-	Rohde & Schwarz	12 M	5	31.07.2010
340	Univ. Communication Tester	CMD 55	849709/037	Rohde & Schwarz	24 M	-	31.03.2012
341	digital multimeter	Fluke 112	81650455	Fluke	24 M	-	31.03.2012
342	digital multimeter	Voltcraft M-4660A	IB 255466	Voltcraft	24 M	-	31.03.2011
344	adaptor 150/50 Ohm	150/50	-	Krohne	12 M	-	31.03.2011
345	adaptor 150/50 Ohm	150/50	-	Krohne	12 M	-	31.03.2011
347	laboratory site	radio lab.	-	-	-	3	
348	laboratory site	EMI conducted	-	-	-	3	
349	car battery 12 V	car battery 12 V	without	-	-	3	
350	car battery 12 V	car battery 12 V	without	-	-	3	
354	DC - power supply 40A	NGPE 40/40	448	Rohde & Schwarz	pre-m	-	
355	power meter	URV 5	891310/027	Rohde & Schwarz	12 M	-	31.03.2011
356	power sensor	NRV-Z1	882322/014	Rohde & Schwarz	24 M	-	31.03.2011
357	power sensor	NRV-Z1	861761/002	Rohde & Schwarz	24 M	-	31.03.2011
365	10V Insertion Unit 50 Ohm	URV5-Z2	100880	Rohde & Schwarz	24 M	-	31.03.2012
366	Ultra Compact Simulator	UCS 500 M4	V0531100594	EM-Test	12 M	-	01.04.2011
367	audio measurement amplifier	2636	316832/001	Brüel & Kjaer	12 M	-	31.03.2011
369	insertion unit (SAR-EMS, Ch. A)	URV5-Z2	100301	Rohde & Schwarz	24 M	-	31.03.2011
370	insertion unit (SAR-EMS, Ch. B)	URV5-Z2	100302	Rohde & Schwarz	24 M	-	31.03.2011
371	Bluetooth Tester	CBT32	100153	R&S	12 M	-	31.03.2011
373	V-Network 5µH/50 Ohm	ESH3-Z6	100535	Rohde & Schwarz	12 M	-	31.03.2011
374	power amplifier 0,8-3 GHz	60S1G3	306528	Amplifier Research	-	1a	30.05.2011
375	directional coupler	DC7144M1	306498	Amplifier Research	-	1a	30.05.2011
376	horn antenna 6 GHz	BBHA9120 E	BBHA 9120 E 179	Schwarzbeck	12 M	-	01.04.2011
377	emi test receiver	ESCS 30	100160	Rohde & Schwarz	12 M	-	31.03.2011
378	broadband RF field monitor	RadiSense III	03D00013SNO-08	DARE B.V.	12 M	-	31.03.2011
383	signal generator	SME 03	842 828 /034	Rohde & Schwarz	36 M	-	31.03.2013
386	coupling decoupling network	CDN USB/p	19397	Schaffner	12 M	-	31.03.2011
387	coupling decoupling network	CDN L-801 M2	2051	Lüthi	12 M	-	31.03.2011
388	coupling decoupling network	CDN L-801 T2	1929	Lüthi	12 M	-	31.03.2011
389	digital multimeter	Keithley 2000	0583926	Keithley	24 M	-	31.03.2011
390	Industry Acoustic System	MO 2000 Set	2127100123	Sennheiser	-	4	
392	Radio Communication Tester	MT8820A	6K0000788	Anritsu	12 M	-	31.03.2011
394	power amplifier 80-1000 MHz	BLWA 0810-250/200	045610	Bonn-Elektronik	-	1a	30.05.2011
399	Sound Calibrator	Sound Calibrator 4231	2665101	Brüel & Kjaer	12 M	-	31.03.2011
400	ferrite tube (>15 dB, EN 55022)	FTC 40 X 15 E	5559	Lüthi	36 M	-	31.03.2012
401	ferrite tube (>15 dB, EN 55022)	FTC 40 X 15 E	5560	Lüthi	36 M	-	31.03.2012
431	Model 7405	Near-Field Probe Set	9305-2457	EMCO	-	4	
439	UltraLog-Antenna	HL 562	100248	Rohde + Schwarz	12 M	-	30.04.2011
440	CDN for Datacable	CDN-UTP	CDN-UTP 029	EMC Partner AG,	24 M	-	31.03.2012
441	System CTC-SAR-EMI Cable Loss	System EMI field (SAR)	-	ETS	12 M	5	31.08.2011
442	System CTC-SAR-EMS	System EMS field (SAR)	-	ETS-	12 M	5	30.04.2011
443	System CTC-FAR-EMI-Spuri	System CTC-FAR-EMI-	-	ETS-Lindgren/Cetecom	12 M	5	30.06.2011
444	System CTC FAR-EMS	System EMS-Field (FAR)	-	ETS Lindgren/Cetecom	12 M	5	30.05.2011
448	notch filter WCDMA FDD II	WRCT 1850.0/2170.0-	5	Wainwright Instruments	12 M	1c	30.05.2011
449	notch filter WCDMA FDD V	WRCT 824.0/894.0-5/40-	1	Wainwright Instruments	12 M	1c	30.05.2011
454	Oscilloscope	HM 205-3	9210 P 29661	Hameg	-	4	
455	Oscilloscope	HP 54602B	US 350 336 45	Hawlett Packard	-	4	
456	DC-Power supply 0-5A	EA 3013 S	207810	Elektro Automatik	pre-m	2	
459	DC -power supply 0-5 A , 0-32 V	EA-PS 2032-50	910722	Elektro Automatik	pre-m	2	
460	Univ. Radio Communication Tester	CMU 200	108901	Rohde & Schwarz	12 M	-	31.03.2011
462	AF-Generator	MX-2020	-	Conrad	-	4	
463	Universal source	HP3245A	2831A03472	Agilent	-	4	
466	digital multimeter	Fluke 112	89210157	Fluke USA	24 M	-	31.03.2012
467	digital multimeter	Fluke 112	89680306	Fluke USA	24 M	-	31.03.2012
468	digital multimeter	Fluke 112	90090455	Fluke USA	24 M	-	31.03.2012
477	ReRadiating GPS-System	AS-47	-	Automotive Cons. Fink	-	3	
480	power meter (Fula)	NRVS	838392/031	Rohde & Schwarz	24 M	-	31.03.2011
482	filtermatrix	FilterMatrix SAR I	-	CETECOM (Brl)	-	1d	
484	pre-amplifier 2,5 - 18 GHz	AMF-5D-02501800-25-	1244554	Miteq	12 M	-	01.06.2011
487	System CTC NSA-Verification SAR-EMI	System EMI field (SAR)	-	ETS	12 M	-	30.09.2011
489	emi test receiver	ESU40	1000-30	Rohde & Schwarz	12 M	-	31.03.2011
491	ESD Simulator dito	ESD dito	ditto307022	EM-Test	24 M	-	31.03.2011
498	Power Supply	NGPE 40/40	402	Rohde & Schwarz	-	2	
500	industry Acoustic System	MO 2000 Set	100048	Sennheiser	-	4	
502	band reject filter	WRCG 1709/1786-	SN 9	Wainwright	-	2	
503	band reject filter	WRCG 824/849-814/859-	SN 5	Wainwright	-	2	
517	relais swite matrix	HF Relais Box Keithley	SE 04	Keithley	-	2	
523	Digitalmultimeter	L4411A	MY46000154	Agilent	24 M	-	31.03.2011
524	Voltage Drop Simulator	VDS 200	0196-16	EM Test	24 M	-	31.03.2011
525	Koppelnetzwerk	CNA 200	1196-01	EM Test	24 M	-	31.03.2011
526	Burst Generator	EFT 200 A	0496-06	EM Test	24 M	-	31.03.2011
527	Micro Pulse Generator	MPG 200 B	0496-05	EM Test	24 M	-	31.03.2011
528	Load Dump Simulator	LD 200B	0496-06	EM Test	24 M	-	31.03.2011
529	6 dB Broadband resistive power divider	Model 1515	LH 855	Weinschel			
530	10 dB Broadband resistive power attenuator	R 416110000	LOT 9828	-			

Ref.-No.	Equipment	Type	Serial-No.	Manufacturer	Interval of calibration	Remark	Cal due
533	Impedance Stabilization Network	ISN T200A	25706	Teseq	12 M	-	31.03.2011
534	Impedance Stabilization Network	ISN T400A	Teseq	Teseq	12 M	-	31
535	Impedance Stabilization Network	ISN T800	26321	Teseq	12 M	-	31.03.2011
536	Impedance Stabilization Network	ISN ST08	25867	Teseq	12 M	-	31.03.2011
541	Impedance Stabilization Network	ISN T8-Cat6	26373	Teseq Berlin	12 M	-	31.03.2011
547	Univ. Radio Kommunikation Tester	CMU 200	835390/014	Rohde & Schwarz	12 M	-	31.03.2011
548	Digital-Barometer	GBP 2300	without	Greisinger GmbH	36/12 M	-	31.03.2012
549	Log.Per-Antenna	HL025	1000060	Rohde & Schwarz	36/12 M	-	31.03.2012
552	high pass filter 2.8-18GHz	WHKX 2.8/18G-10SS	4	Wainwright	12 M	-	30.06.2011
558	System CTC FAR S-VSWR	System CTC FAR S-	-	CTC	24 M	-	31.08.2011
574	Biconilog Hybrid Antenna	BTA-L	980026L	Frankonia	36/12 M	-	30.03.2013
584	Spectrum Analyzer	FSU 8	100248	Rohde & Schwarz	12 M	-	31.03.2012
592	CDN-HDMI	CDN-HDMI	A3029004	Frankonia / Dr.Hubert	12 M	-	31.03.2011
594	Kommunikation Tester	CMW500	101757	Rohde & Schwarz	24 M	-	31.03.2012
595	Analog Adder	TS8910	-	Rohde & Schwarz	pre-m	-	-
598	Spectrum Analyser	FSEM 30	831259/013	Rohde & Schwarz	12 M	-	13.01.2011
436	Universal Radiokommunikation Tester	CMU 200	103083	Rohde & Schwarz	12 M	-	31.03.2011

8.1.3. Legend

Note / remarks		Calibrated during system calibration:
	1a	System CTC-SAR-EMS (Ref.-No. 442)
	1b	System-CTC-EMS-Conducted (Ref.-No. 335)
	1c	System CTC-FAR-EMI-spurious emission (Ref.-No . 443)
	1d	System CTC-SAR-EMI (Ref.-No . 441)
	1e	System CTC-OATS (EMI radiated) (Ref.-No. 337)
	1 f	System CTC-CTIA-OTA (Ref.-No . 420)
	1 g	System CTC-FAR-EMS (Ref.-No . 444)
	2	Calibration or equipment check immediately before measurement
	3	Regulatory maintained equipment for functional check or support purpose,
	4	Ancillary equipment without calibration e.g. mechanical equipment or monitoring equipment
	5	Test System

Interval of calibration	12 M	12 month
	24 M	24 month
	36 M	36 month
	24/12 M	Calibration every 24 months, between this every 12 months internal validation
	36/12 M	Calibration every 36 months, between this every 12 months internal validation
	Pre-m	Check before starting the measurement
	-	Without calibration

Annex 1: Diagrams
to TEST REPORT
No.: 2-20795542b/11

According to:
FCC Regulations
FCC Part 22H/24E
FCC Part 15.207C
FCC Part 15.209C
&
IC Regulations
RSS-132, Issue 2
RSS-133, Issue 5
RSS-Gen, Issue 2

for

Cinterion Wireless Modules GmbH

Quad-Band GSM/GPRS Module BGS2-W
FCC-ID: QIPBGS2
IC: 7830A-BGS2







Laboratory Accreditation and Listings			
 D-PL-12047-01-01	 MRA US-EU 0003	 Industry Canada Reg. No.: 3462D-1 3462D-2	 Reg. No.: R-2665, R-2666 C-2914, T-1967 G-301
 LAB CODE 20011130-00			
accredited according to DIN EN ISO/IEC 17025			
CETECOM GmbH Laboratory Radio Communications & Electromagnetic Compatibility Im Teelbruch 116 • 45219 Essen • Germany Registered in Essen, Germany, Reg. No.: HRB Essen 8984 Tel.: + 49 (0) 20 54 / 95 19-954 • Fax: + 49 (0) 20 54 / 95 19-964 E-mail: info@cetecom.com • Internet: www.cetecom.com			

Table of contents

1. DIAGRAMS	3
1.1. 26dBc Emission bandwidth	3
1.2. 99% Occupied bandwidth	7
1.3. Spurious emissions conducted – GSM850 Mode (TX-mode)	10
1.4. Spurious emissions conducted – GSM1900 Mode (TX-mode)	18
1.5. Spurious emissions radiated – GSM850 Mode	26
1.6. Spurious emissions radiated – GSM1900 Mode	48
1.7. Radiated emissions in the frequency range above 18GHz – GSM1900 Mode	76
1.8. Radiated magnetic field strength measurements (f<30MHz)	78
1.9. Conducted emissions on AC-Power lines	84

1. Diagrams

1.1. 26dBc Emission bandwidth

GSM 850

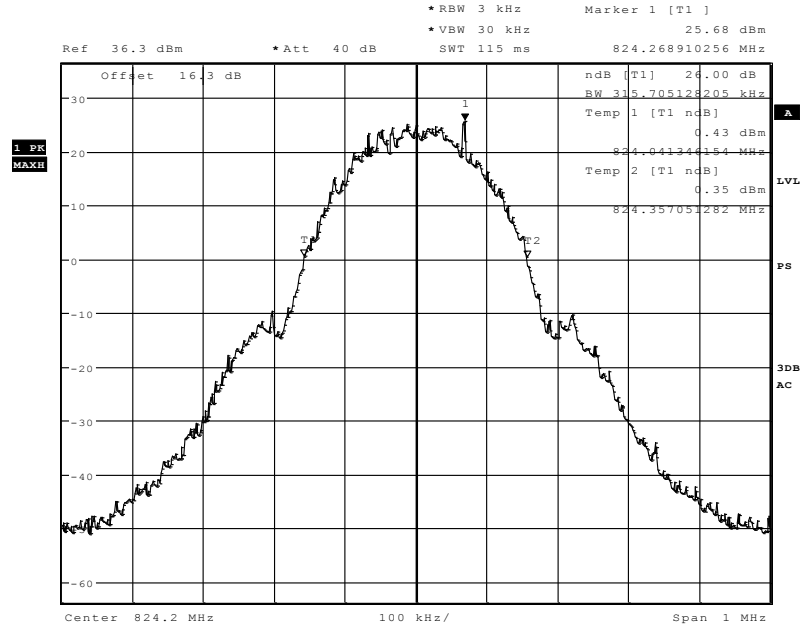

Date: 9.FEB.2011 10:57:21

Channel 128

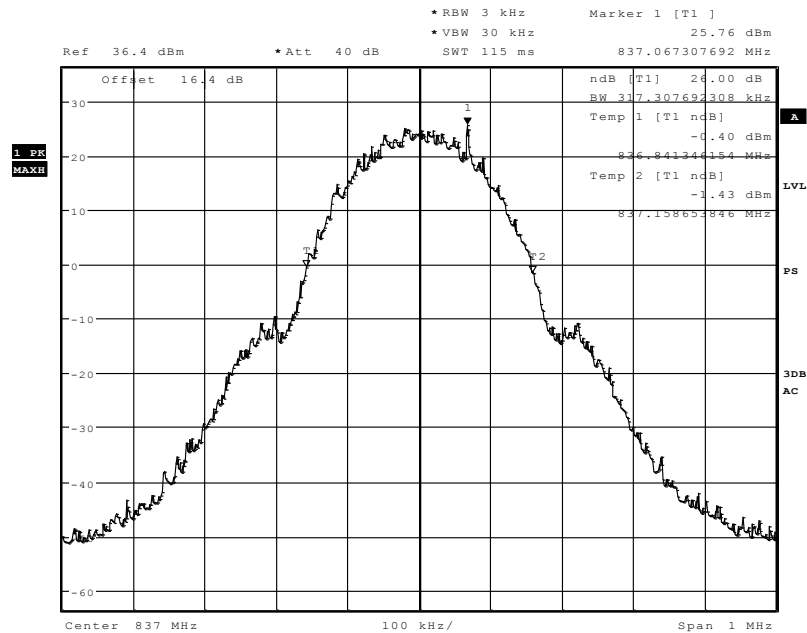

Date: 9.FEB.2011 10:54:27

Channel 192

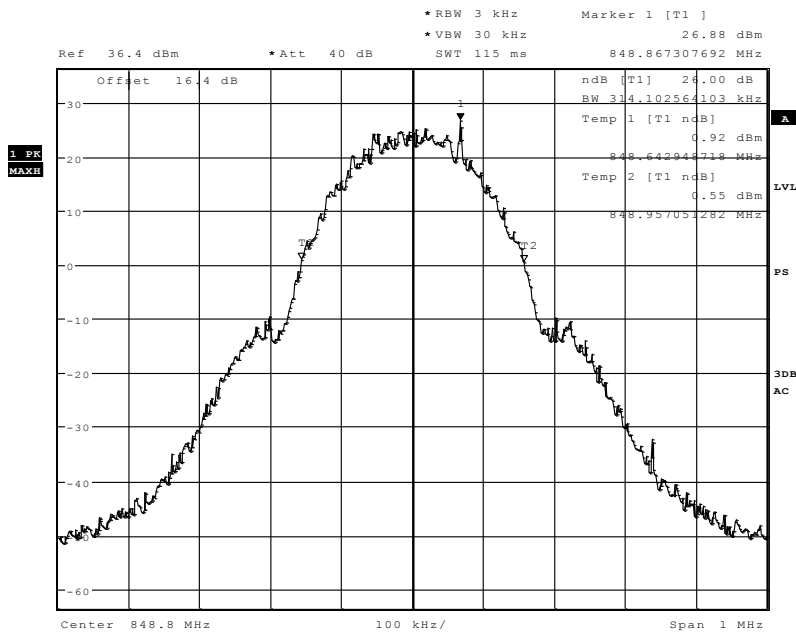

Date: 9.FEB.2011 10:50:32

Channel 251

GSM 1900

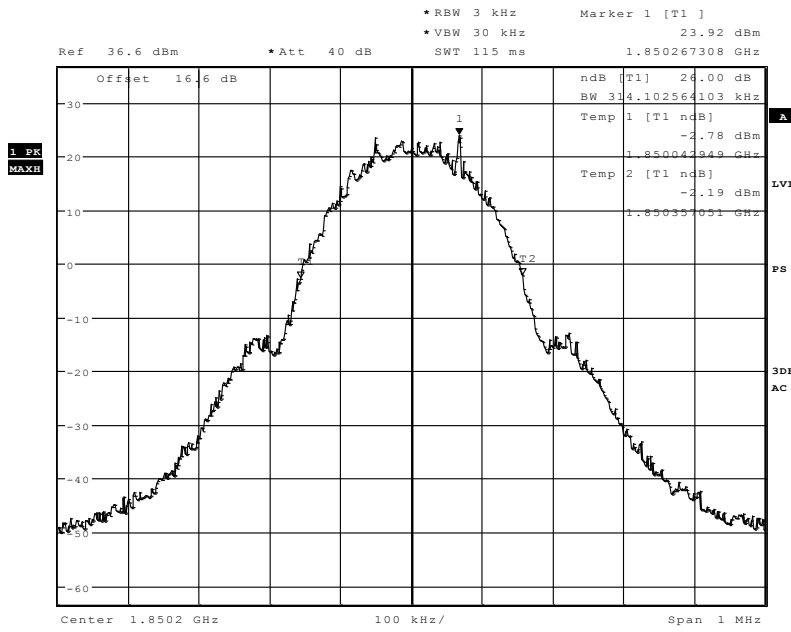

Date: 9.FEB.2011 11:40:39

Channel 512

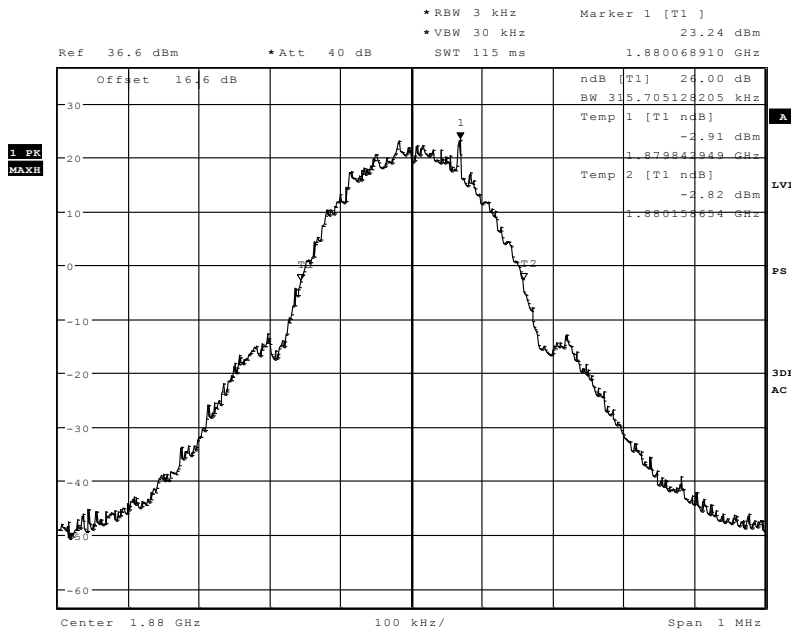

Date: 9.FEB.2011 11:36:54

Channel 661

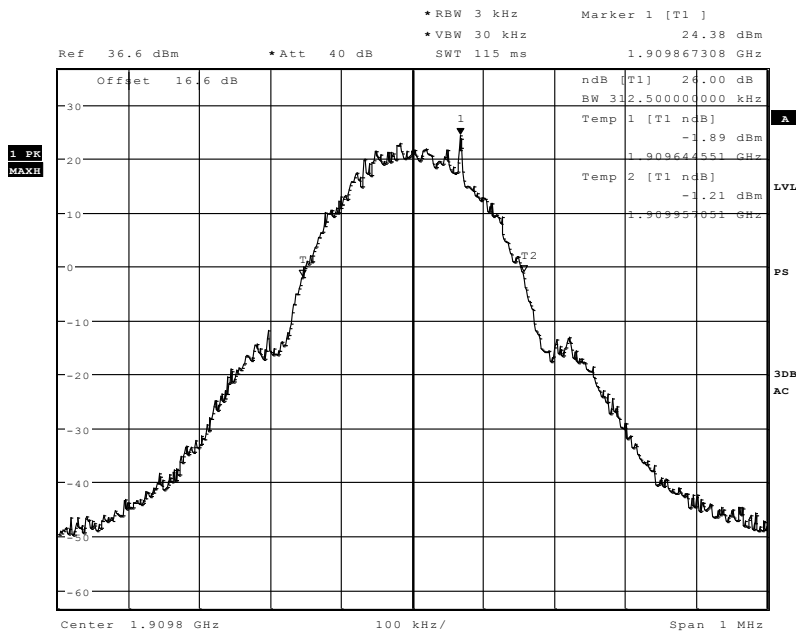

Date: 9.FEB.2011 11:33:01

Channel 810

1.2. 99% Occupied bandwidth

GSM 850

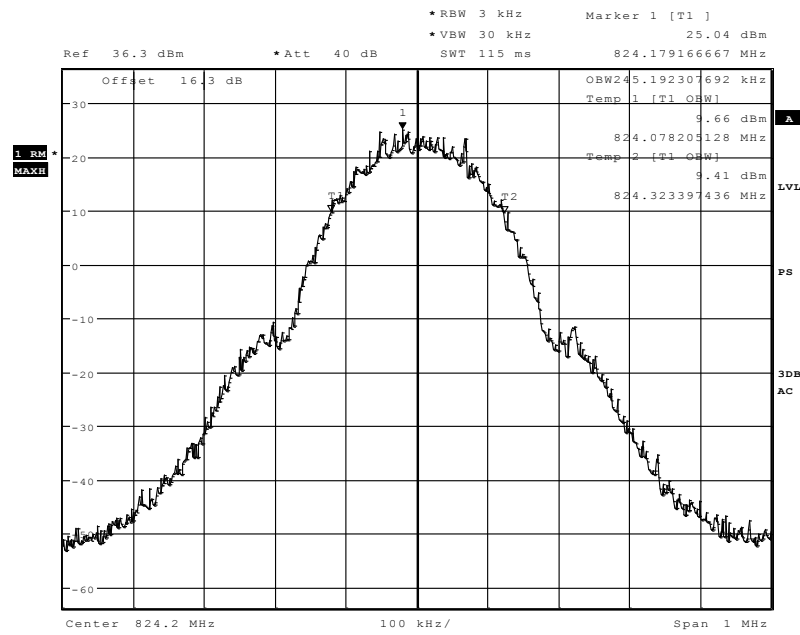

Date: 9.FEB.2011 11:02:10

Channel 128

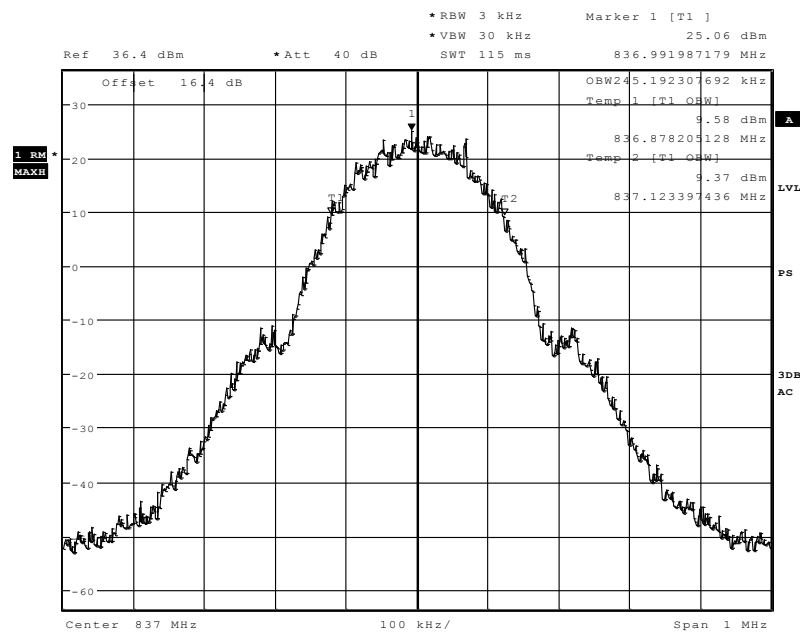

Date: 9.FEB.2011 11:04:51

Channel 192

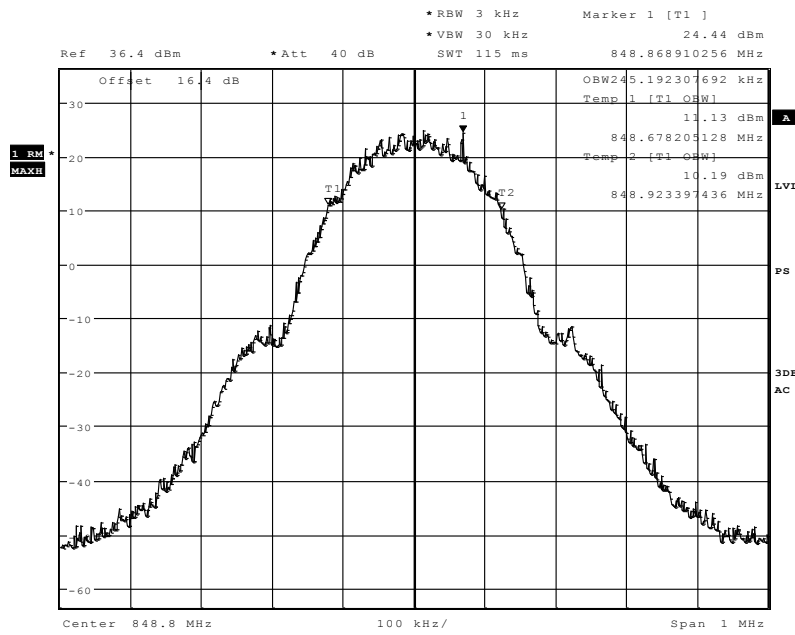

Date: 9.FEB.2011 11:08:50

Channel 251

GSM 1900

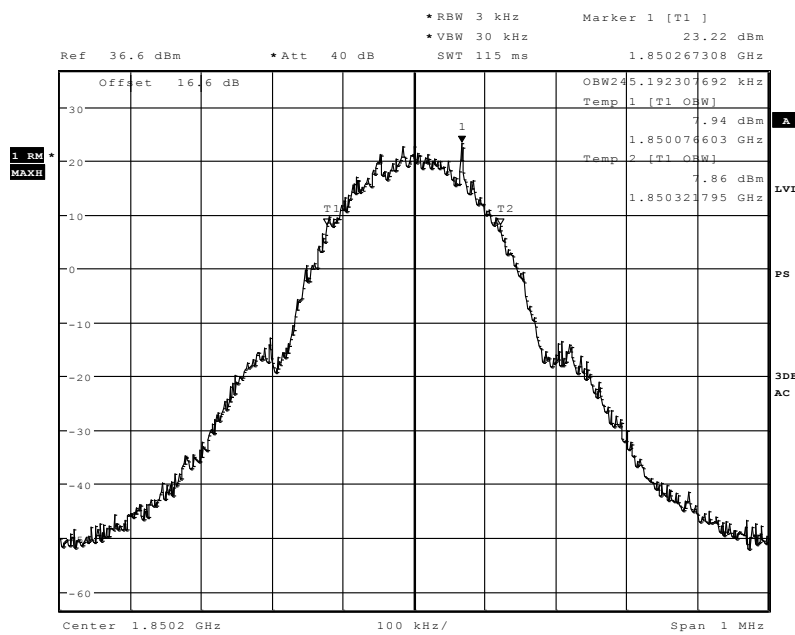

Date: 9.FEB.2011 11:20:55

Channel 512

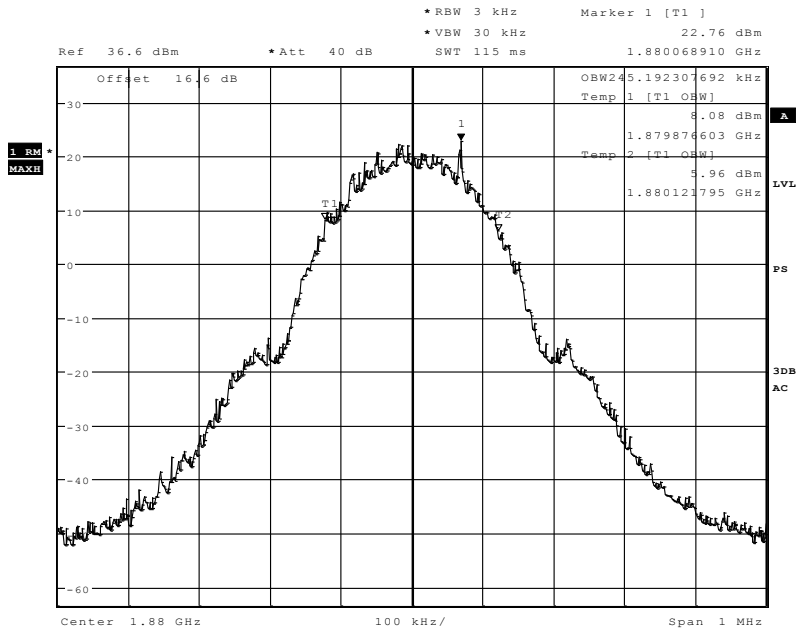

Date: 9.FEB.2011 11:24:29

Channel 661

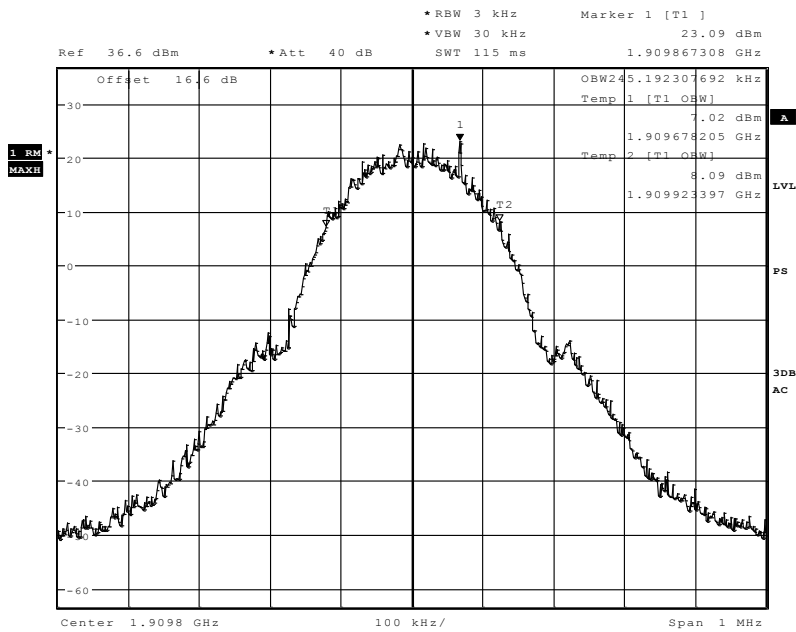

Date: 9.FEB.2011 11:27:44

Channel 810

1.3. Spurious emissions conducted – GSM850 Mode (TX-mode)

Diagram No. 14.01 (Channel 128)

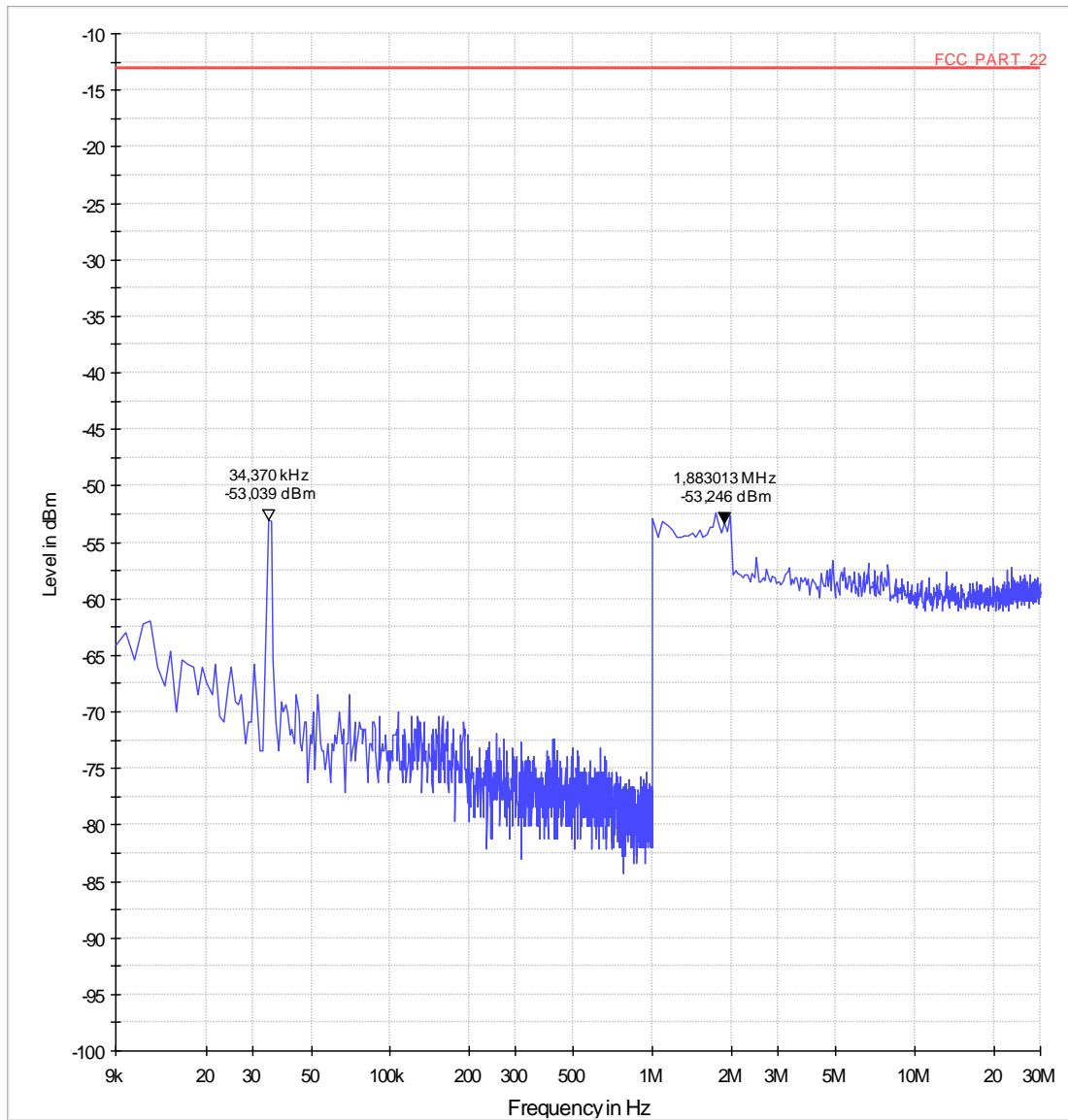

Diagram No. 14.02 (Channel 192)

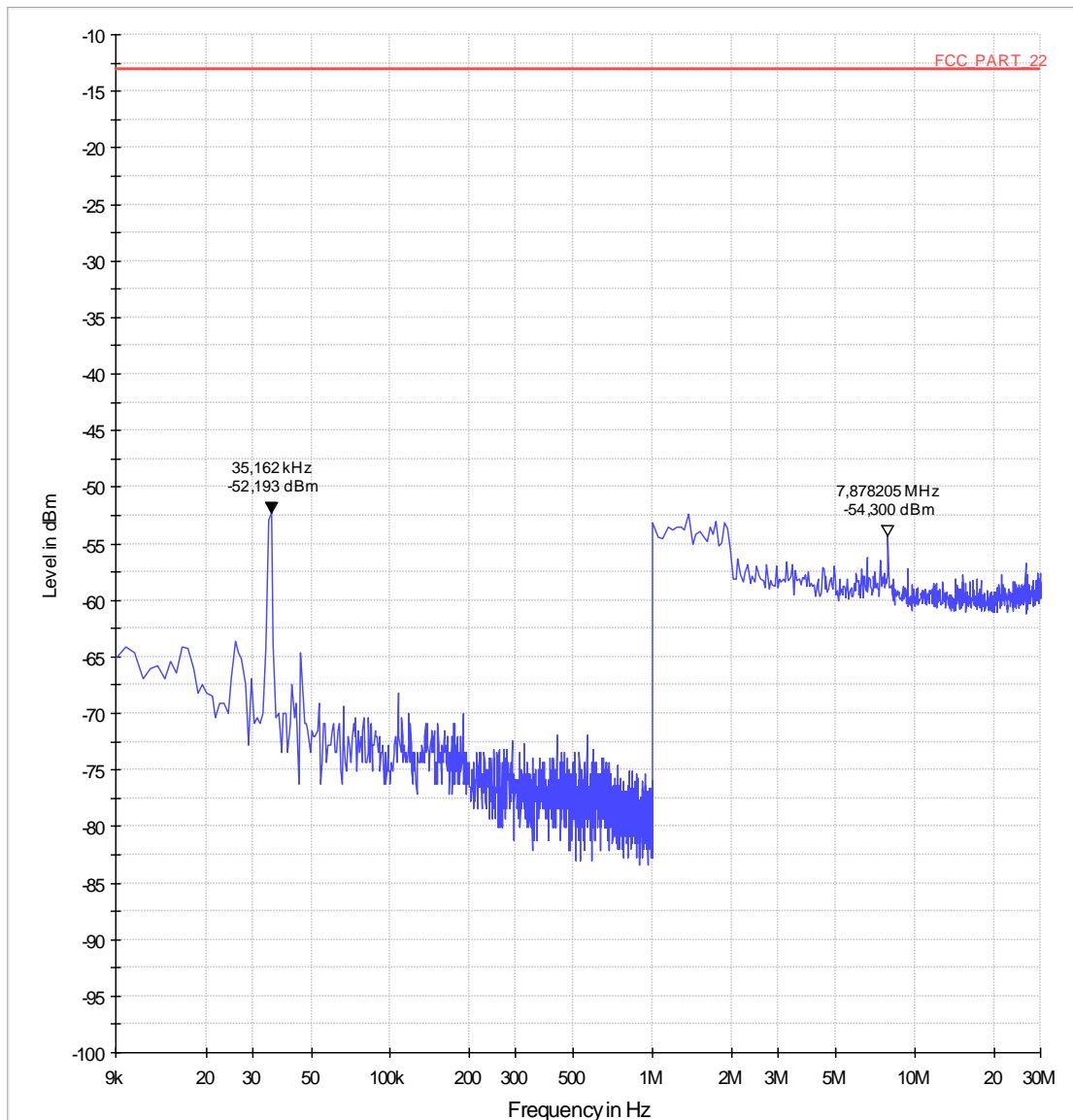

Diagram No. 14.03 (Channel 251)

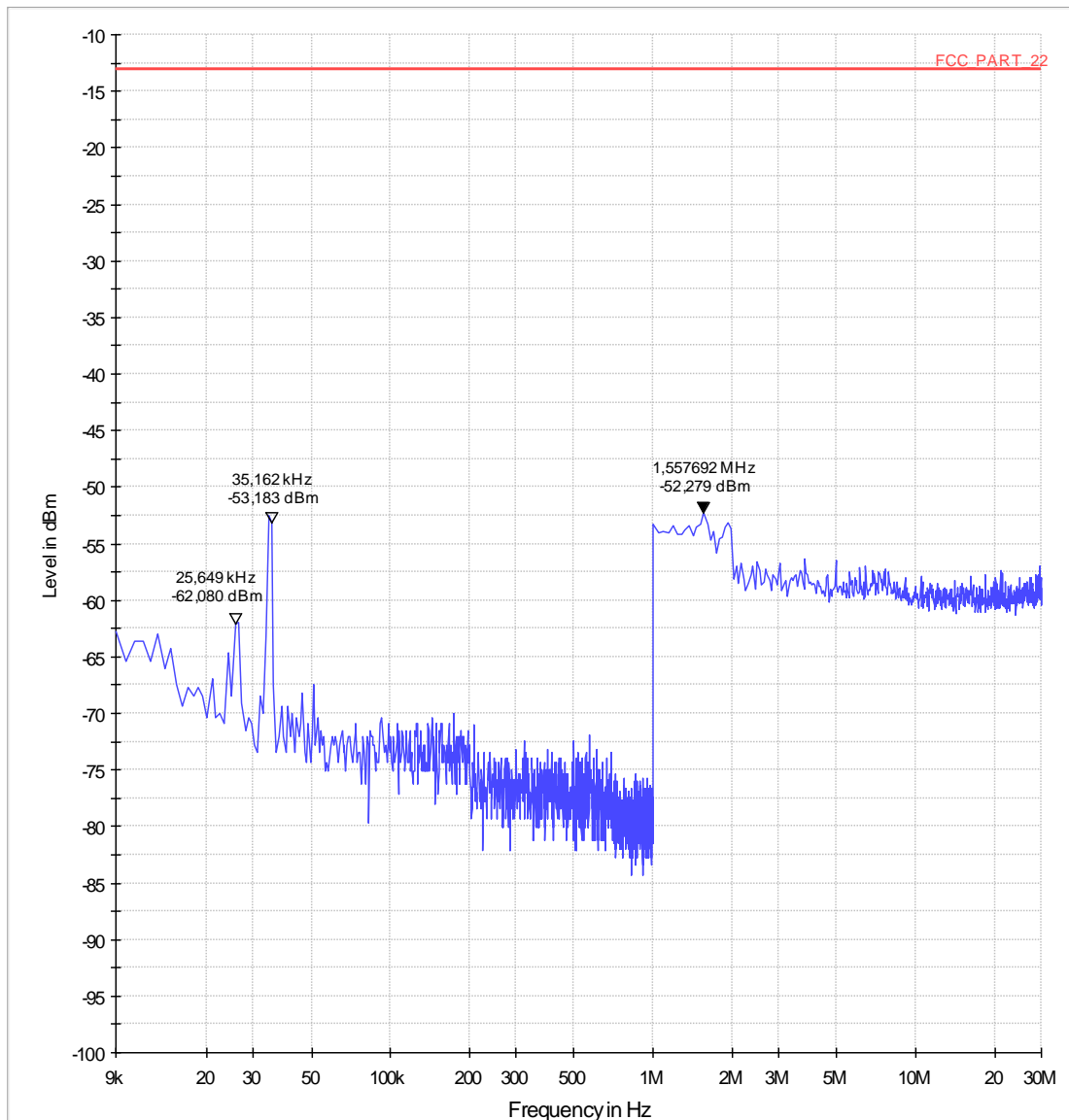

Diagram No. 14.04 (Channel 128)

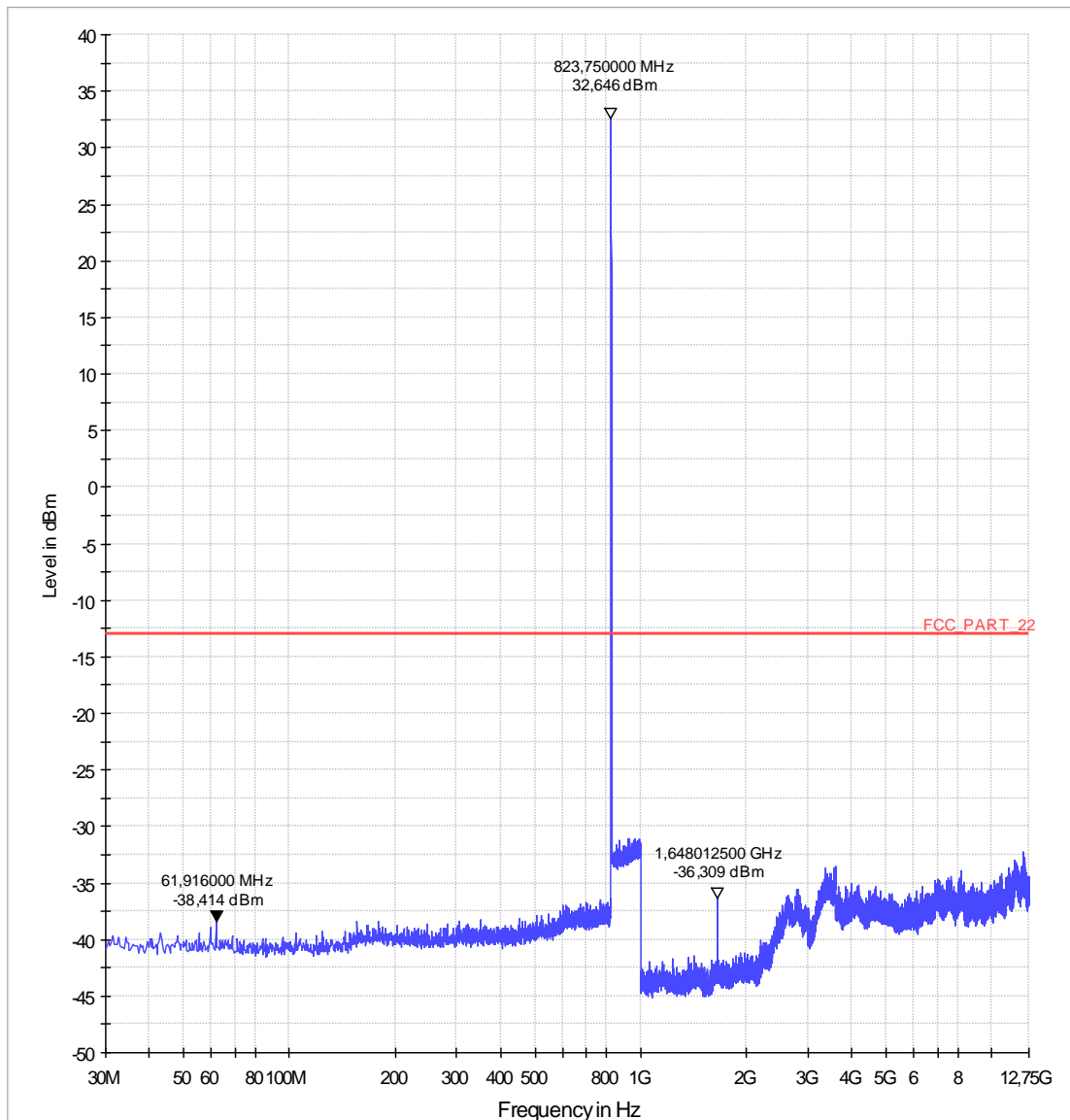

Diagram No. 14.05 (Channel 192)

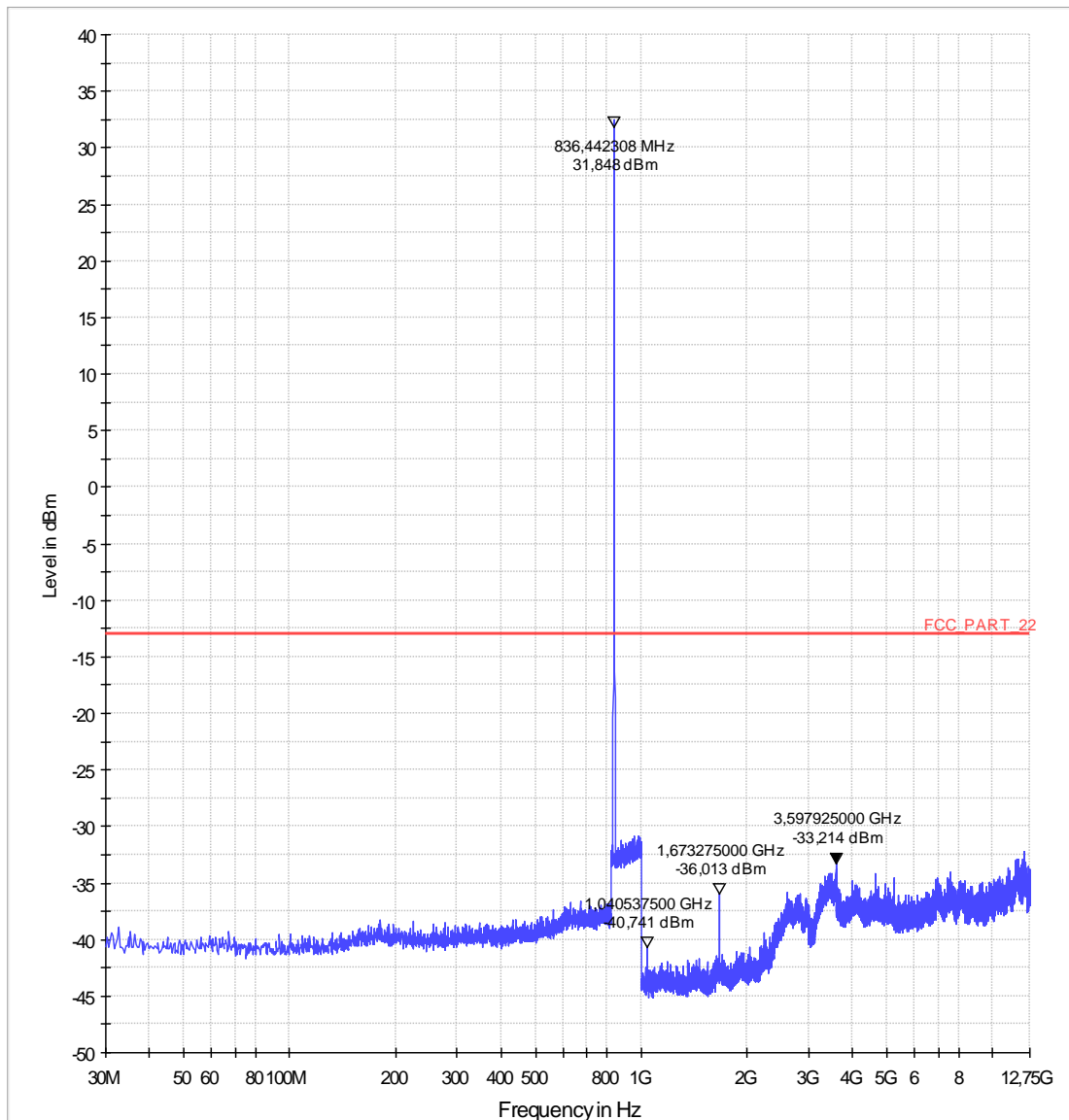

Diagram No. 14.06 (Channel 251)

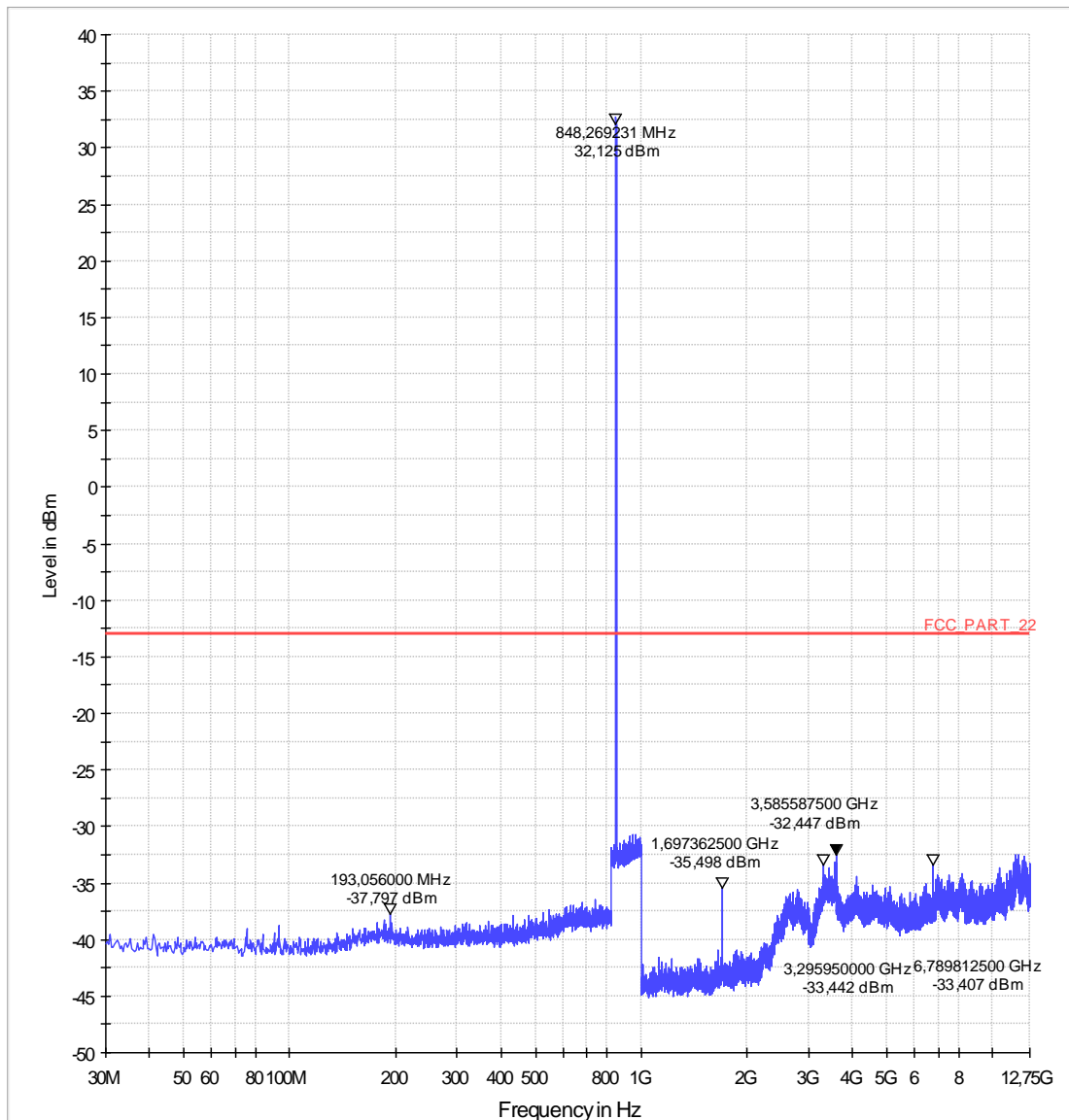

Diagram No. 14.07b (Channel 128)

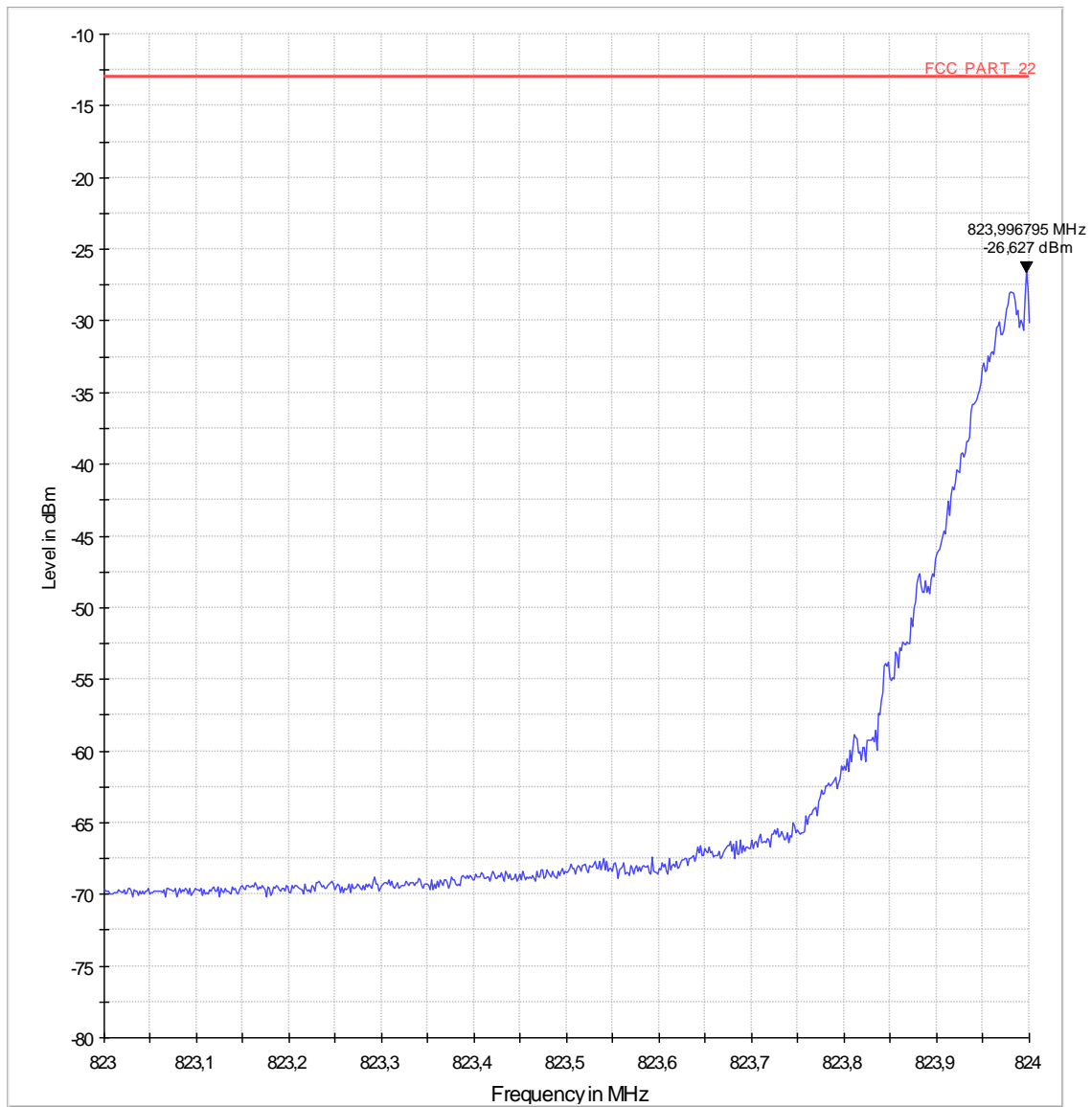
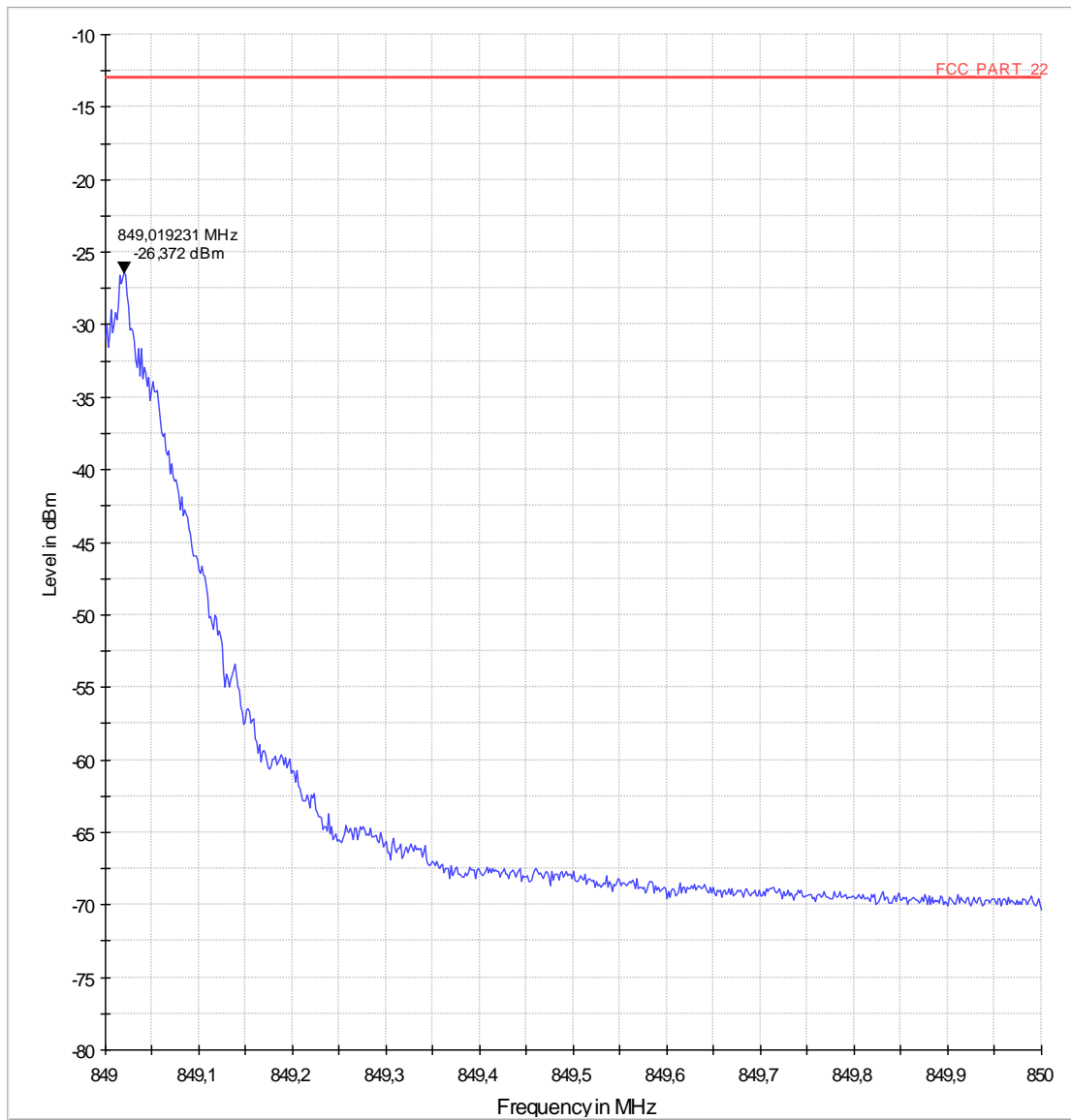

Diagram No. 14.08b (Channel 251)



1.4. Spurious emissions conducted – GSM1900 Mode (TX-mode)

Diagram no. 14.09 (Channel 512)

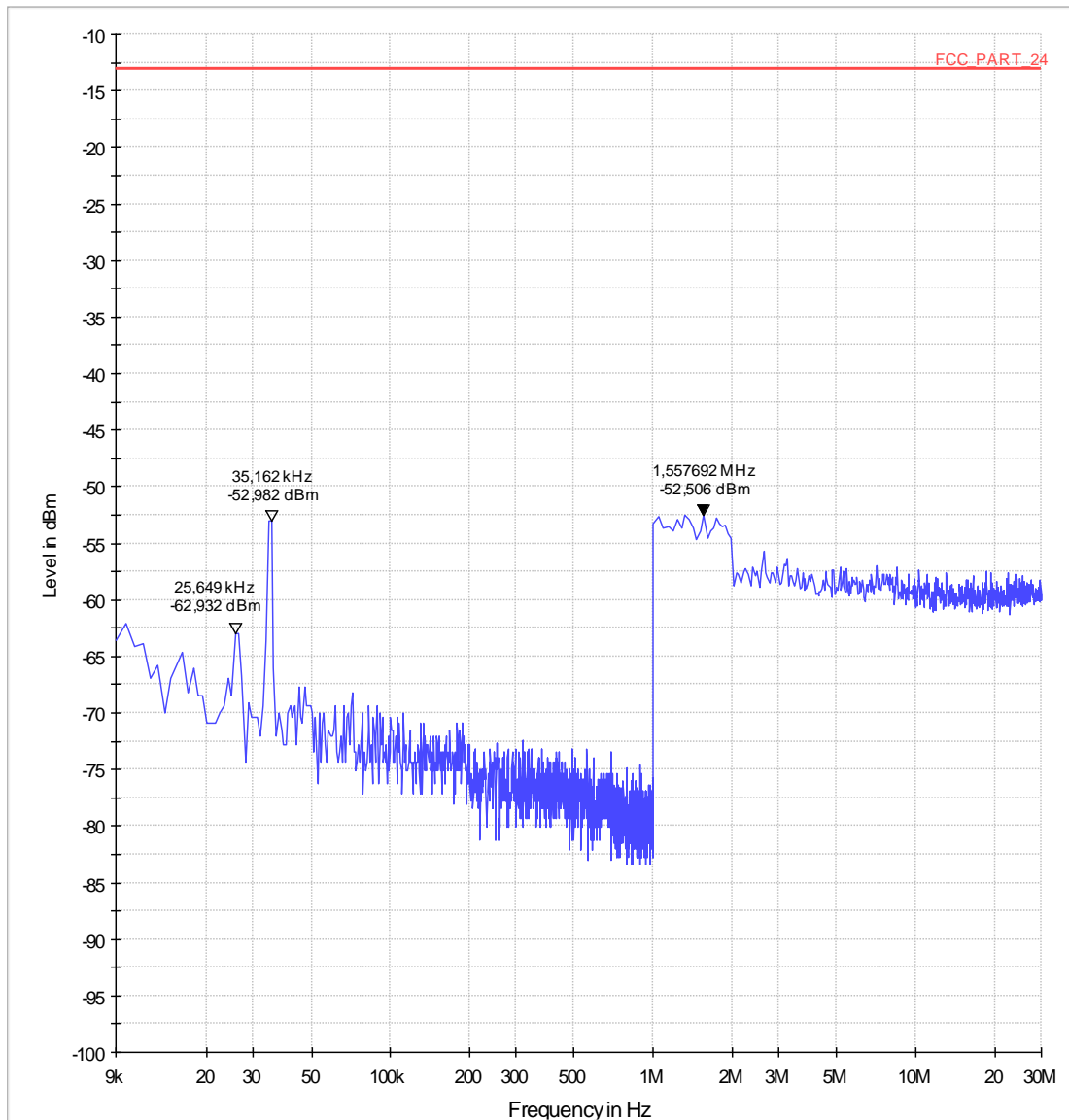

Diagram no. 14.10 (Channel 661)

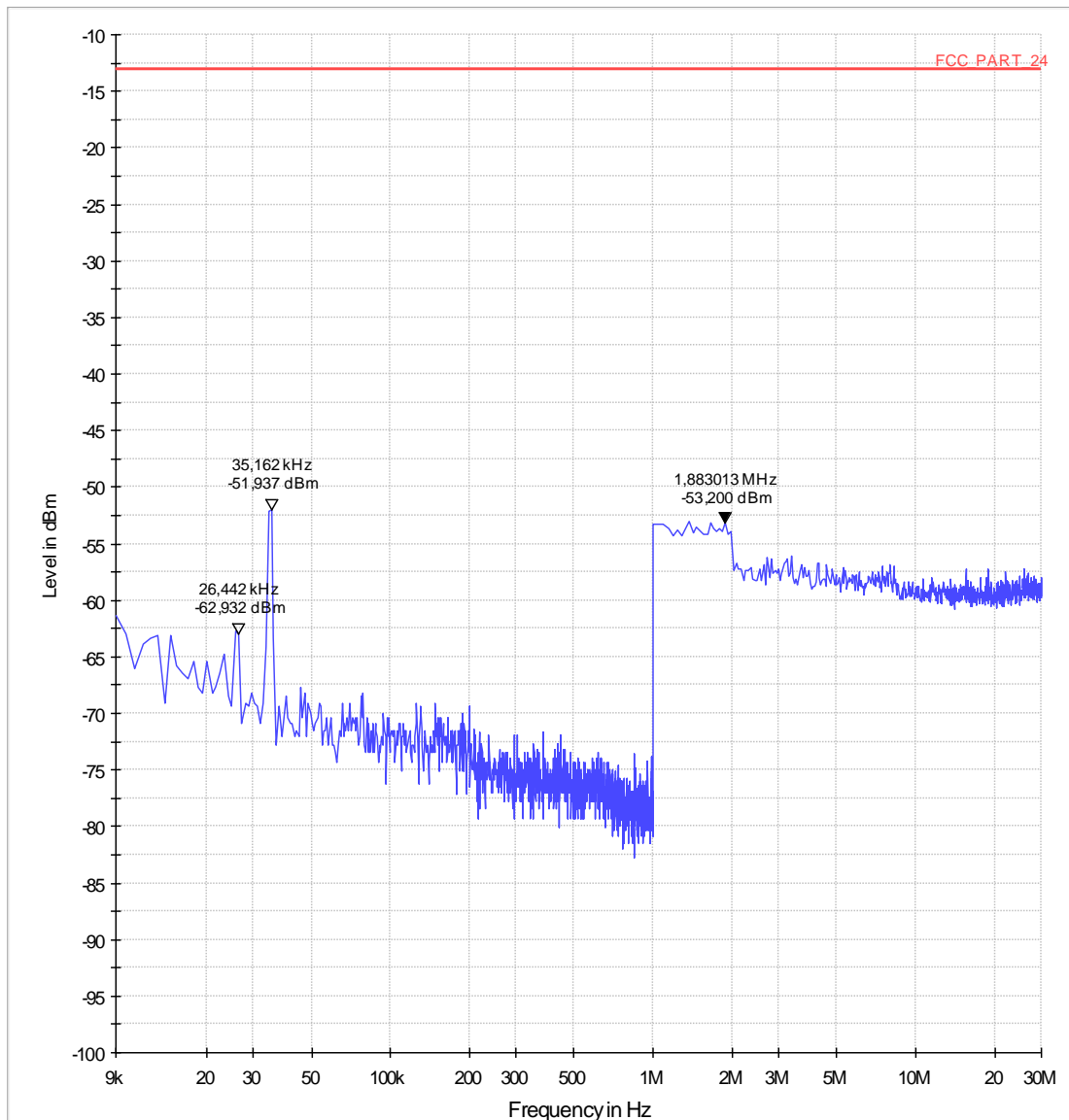

Diagram no. 14.11 (Channel 810)

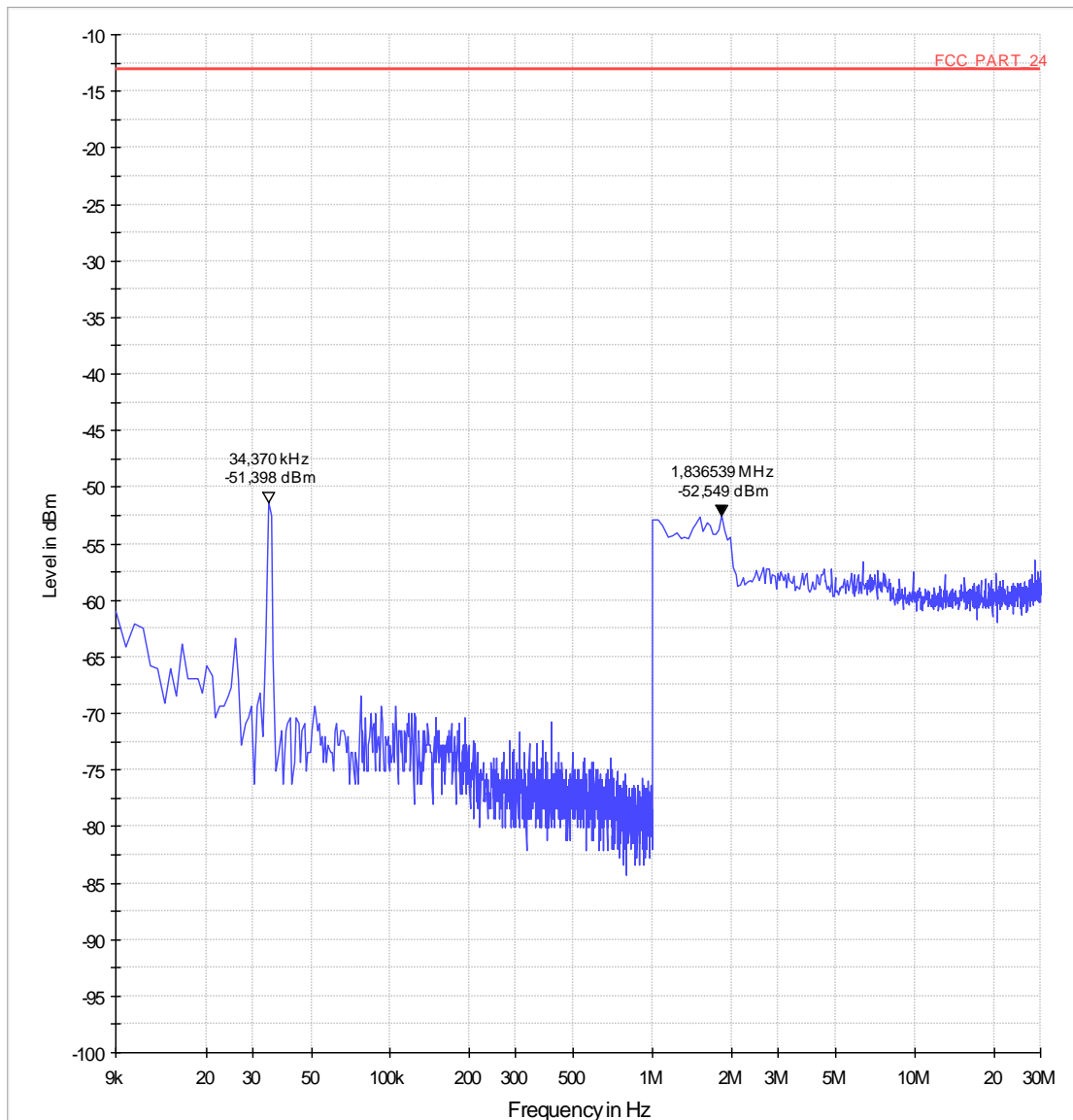

Diagram no. 14.12 (Channel 512)

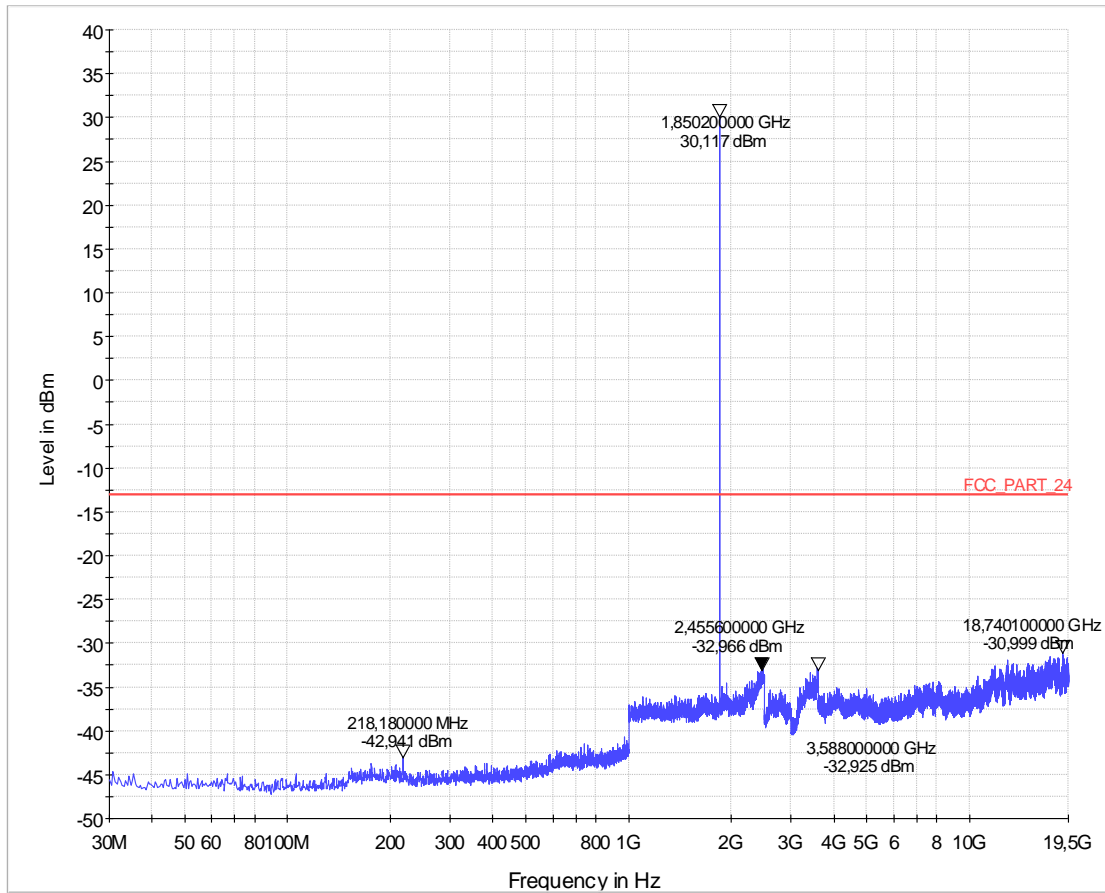

Diagram no. 14.13 (Channel 661)

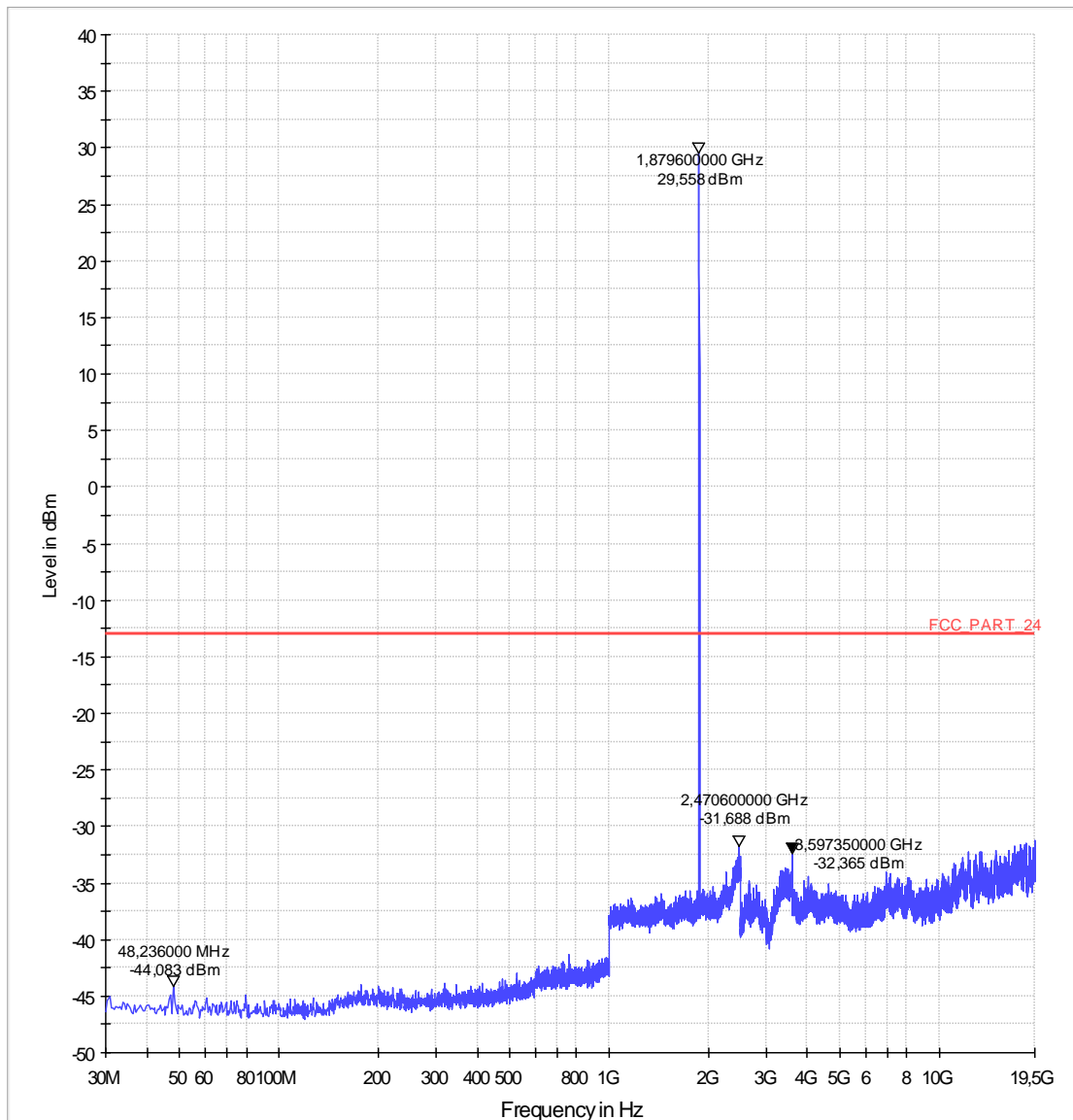

Diagram no. 14.14 (Channel 810)

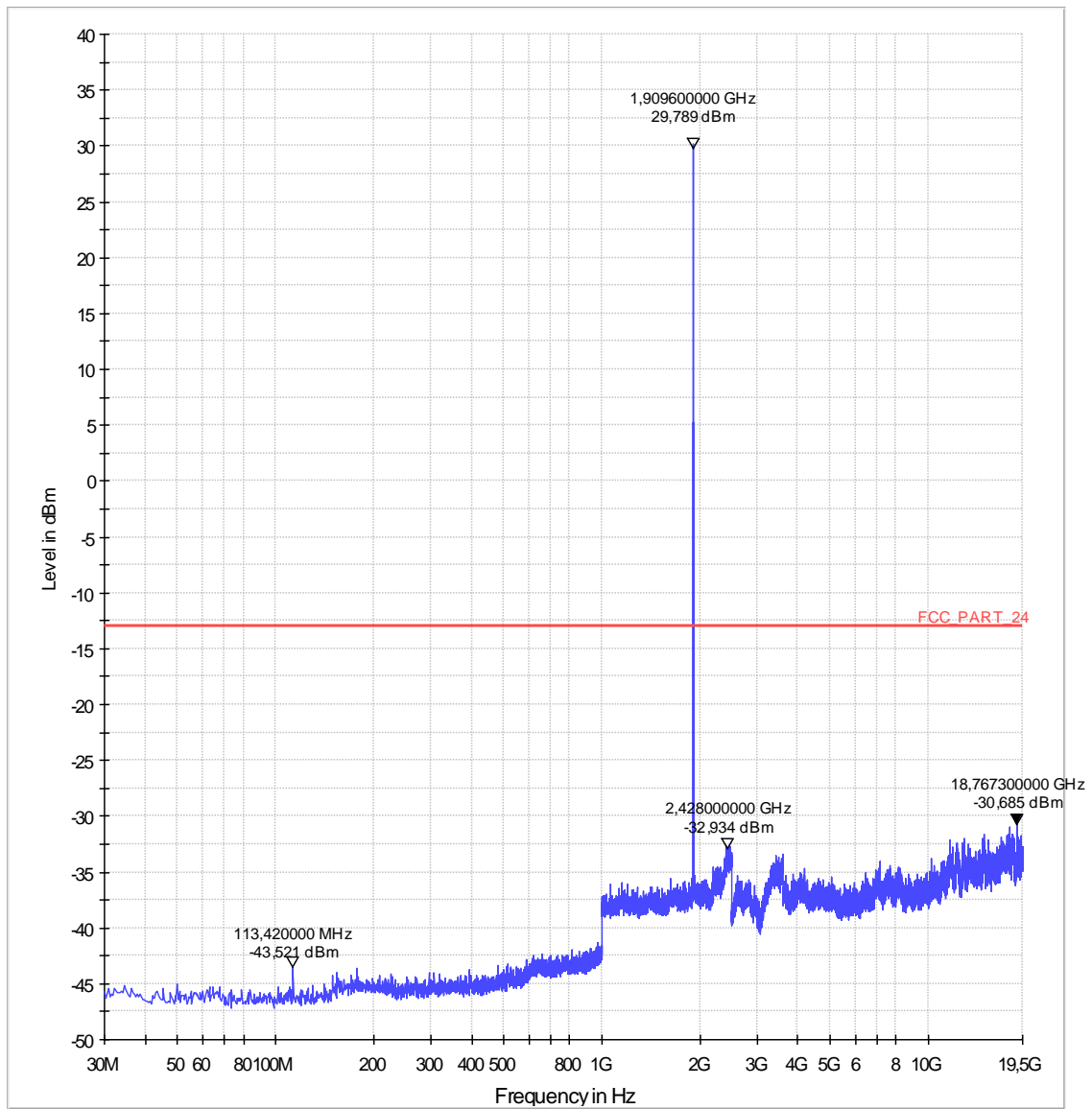

Diagram no. 14.15b (Channel 512)

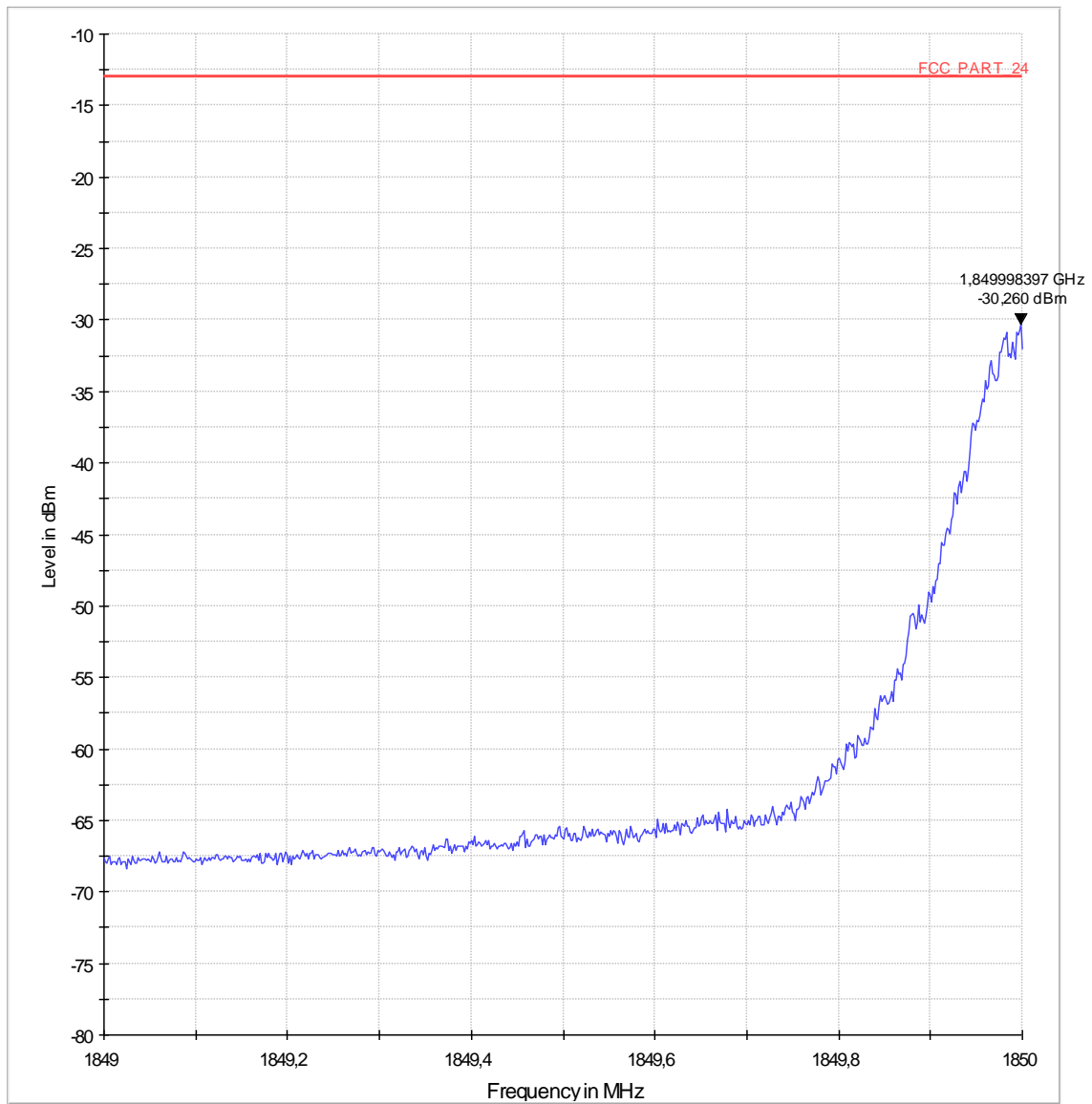
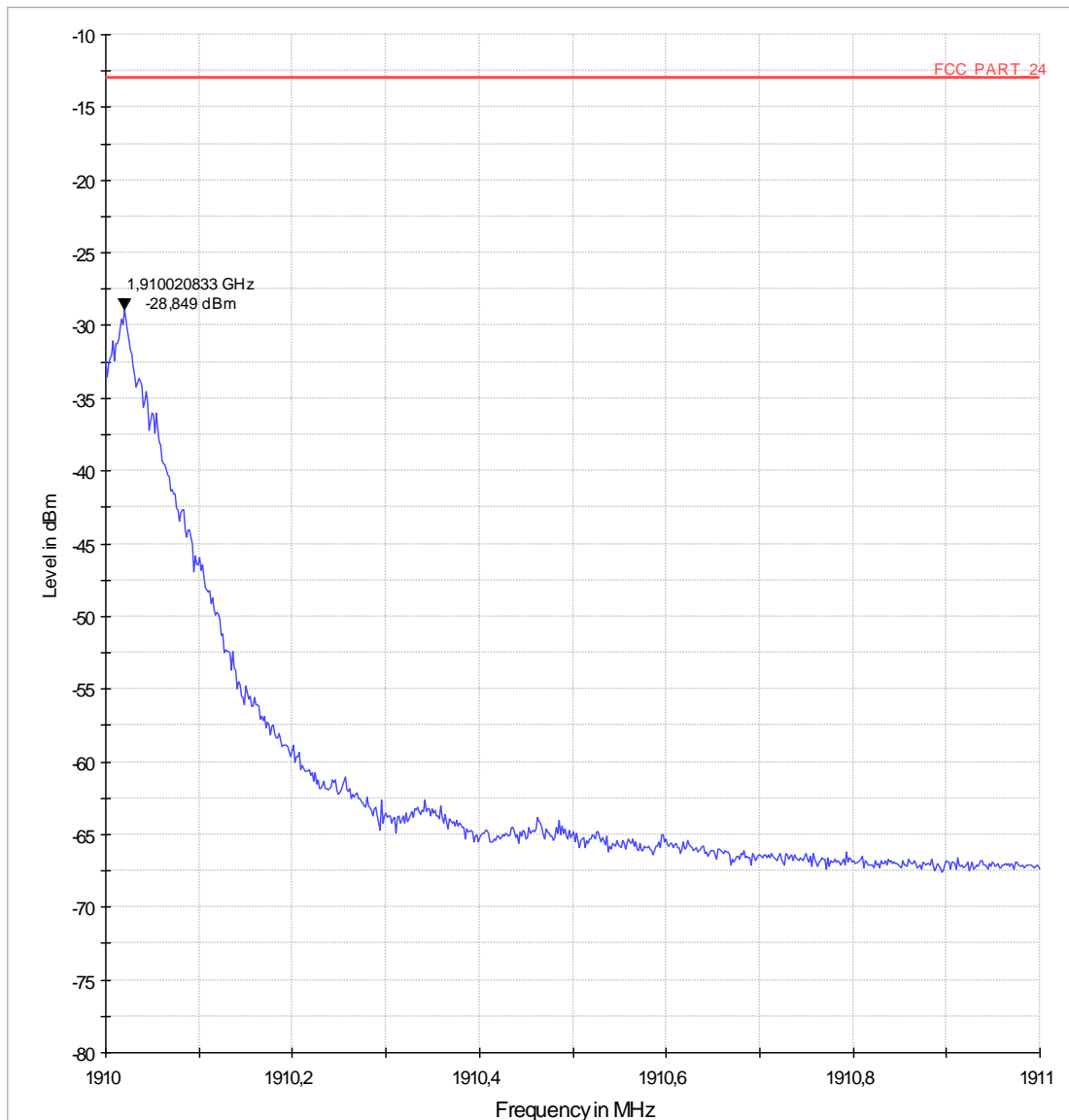
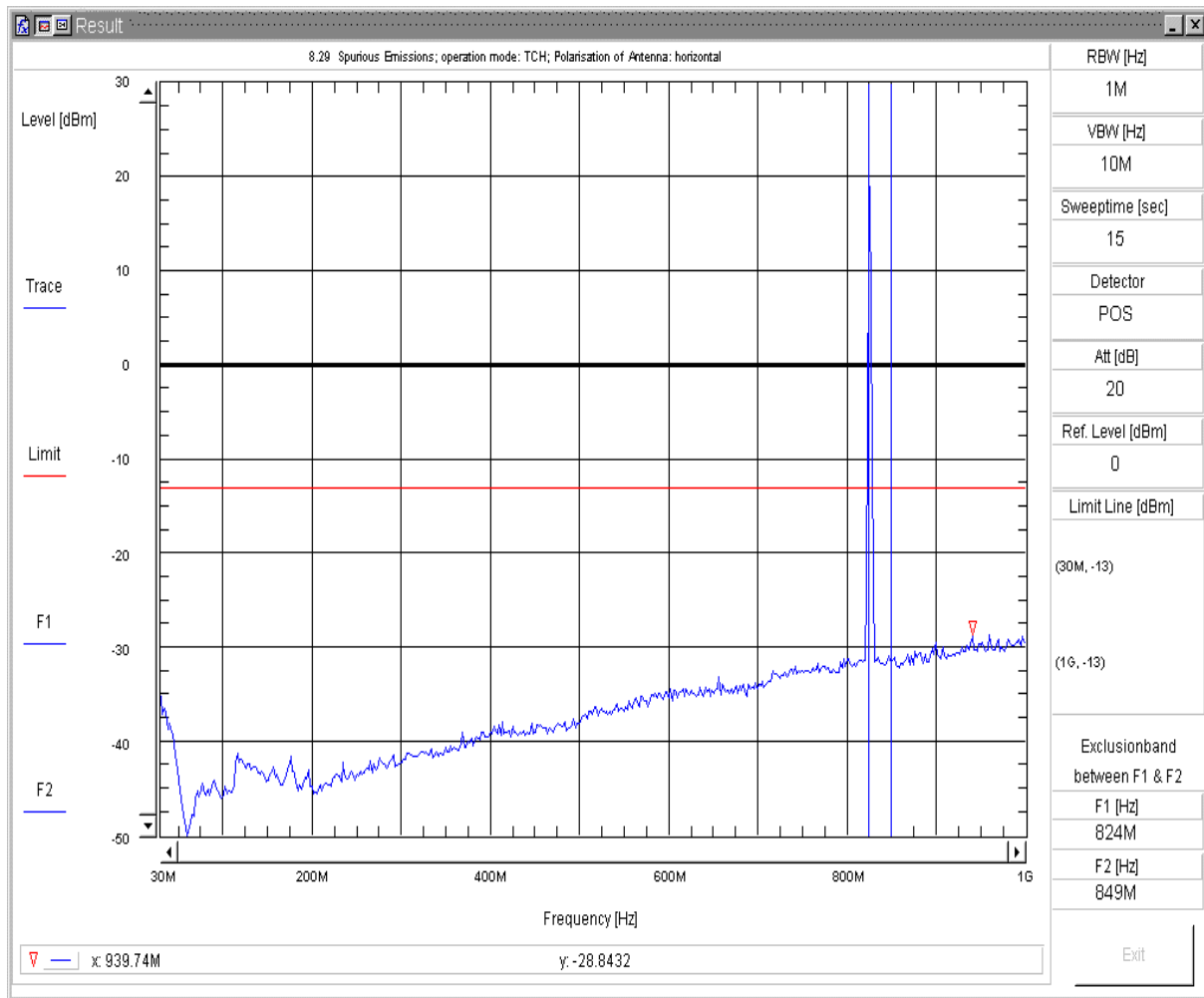

Diagram no. 14.16b (Channel 810)



1.5. Spurious emissions radiated – GSM850 Mode



8.29 Radiated Spurious Emission

Transducer: c:\vee_user\spuri_V7\FCC_Part_22.917_(GSM_850)\TD_TX_H
 Sweepnr: Sweep1
 Pol. of Antenna: horizontal
 EUT Position: EUT_vertical+horizontal
 EUT OP Mode: FCC_Part_22.917_(GSM_850) TCH
 EUT Description: BGS2-W GSM Module
 EUT add. Info:
 EUT Hardware: B2
 EUT Software:
 EUT Config:
 EUT S/N: 00440108048446800
 Battery: Power Supply (external); Maximum Voltage; 4.5 VDC
 Remark: ARFCN 128
 Operator: Tas
 Testing Site: Fully Anechoic Room (FAR); CETECOM Essen

Fri 04/Feb/2011 15:21:47pff

Spurious Emissions V7.2.5

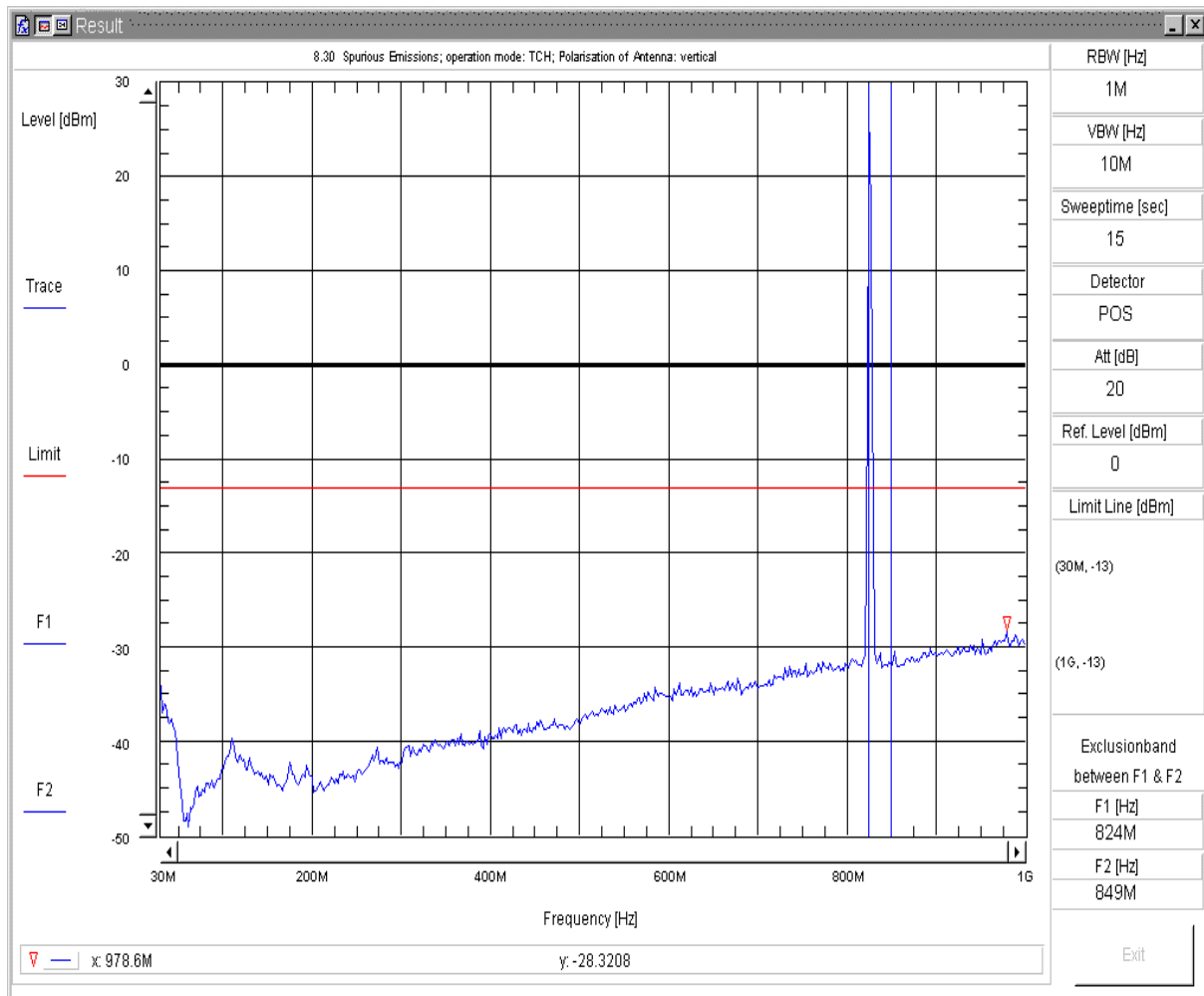

8.30 Radiated Spurious Emission

Transducer: c:\vee_user\spuri_V7\FCC_Part_22.917_(GSM_850)\TD_TX_V
 Sweepnr: Sweep1
 Pol. of Antenna: vertikal
 EUT Position: EUT_vertical+horizontal
 EUT OP Mode: FCC_Part_22.917_(GSM_850) TCH
 EUT Description: BGS2-W GSM Module
 EUT add. Info:
 EUT Hardware: B2
 EUT Software:
 EUT Config:
 EUT S/N: 00440108048446800
 Battery: Power Supply (external); Maximum Voltage; 4.5 VDC
 Remark: ARFCN 128
 Operator: Tas
 Testing Site: Fully Anechoic Room (FAR); CETECOM Essen

Fri 04/Feb/2011 15:27:09ppf

Spurious Emissions V7.2.5

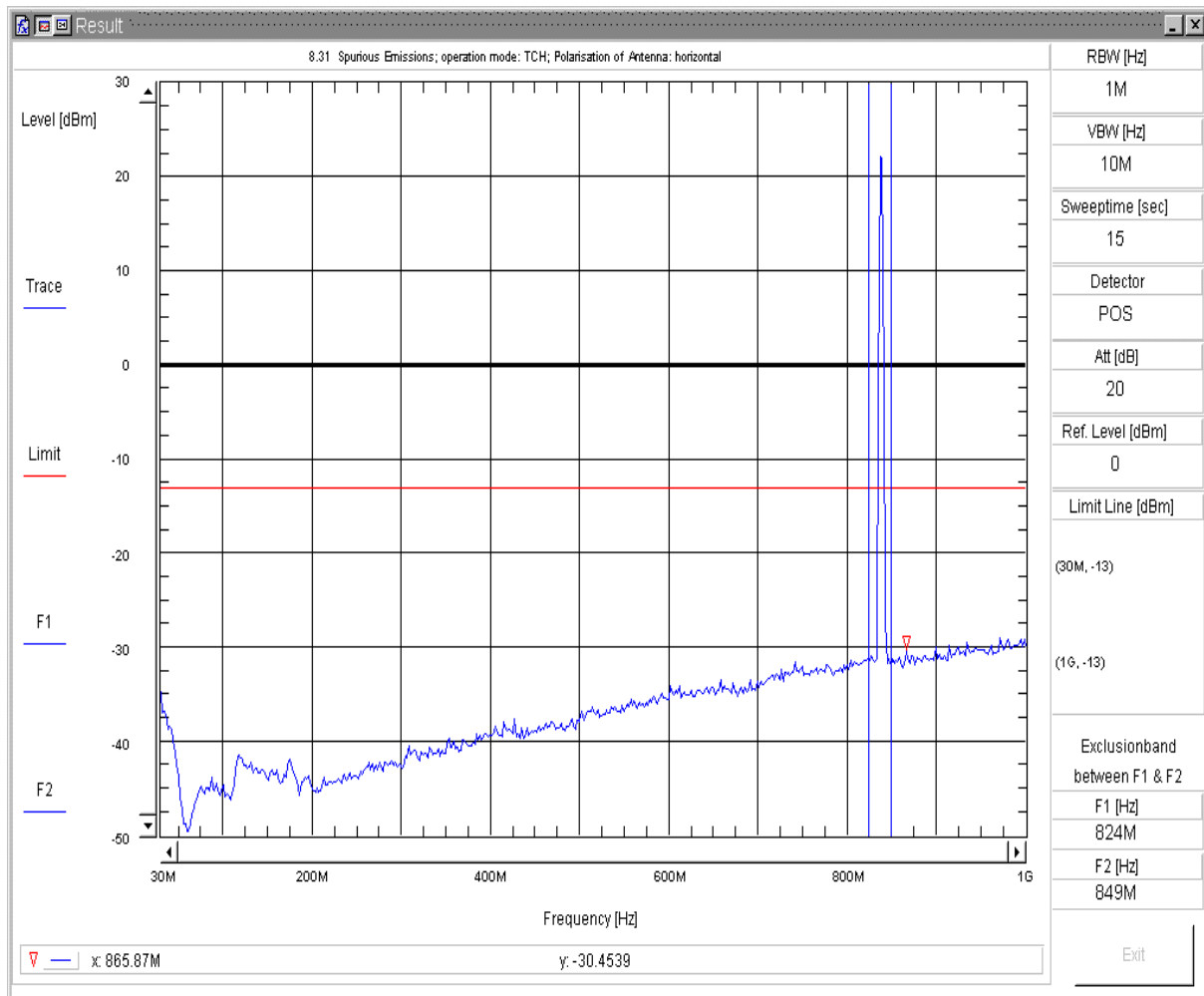

8.31 Radiated Spurious Emission

Transducer: c:\vee_user\spuri_V7\FCC_Part_22.917_(GSM_850)\TD_TX_H
 Sweepnr: Sweep1
 Pol. of Antenna: horizontal
 EUT Position: EUT_vertical+horizontal
 EUT OP Mode: FCC_Part_22.917_(GSM_850) TCH
 EUT Description: BGS2-W GSM Module
 EUT add. Info:
 EUT Hardware: B2
 EUT Software:
 EUT Config:
 EUT S/N: 00440108048446800
 Battery: Power Supply (external); Maximum Voltage; 4.5 VDC
 Remark: ARFCN 192
 Operator: Tas
 Testing Site: Fully Anechoic Room (FAR); CETECOM Essen

Fri 04/Feb/2011 16:50:41pff

Spurious Emissions V7.2.5

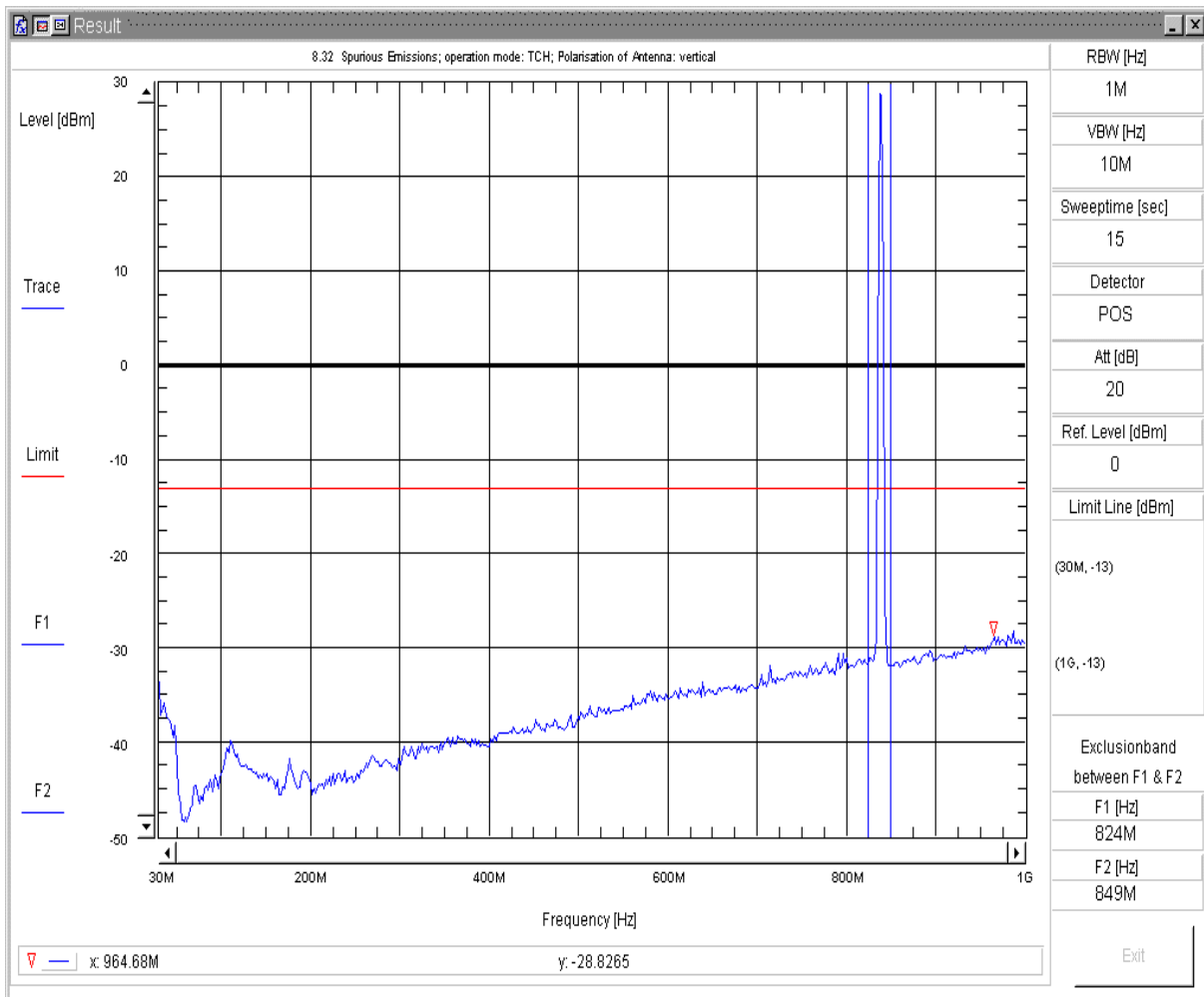

8.32 Radiated Spurious Emission

Transducer: c:\vee_user\spuri_V7\FCC_Part_22.917_(GSM_850)\TD_TX_V
 Sweepnr: Sweep1
 Pol. of Antenna: vertikal
 EUT Position: EUT_vertical+horizontal
 EUT OP Mode: FCC_Part_22.917_(GSM_850) TCH
 EUT Description: BGS2-W GSM Module
 EUT add. Info:
 EUT Hardware: B2
 EUT Software:
 EUT Config:
 EUT S/N: 00440108048446800
 Battery: Power Supply (external); Maximum Voltage; 4.5 VDC
 Remark: ARFCN 192
 Operator: Tas
 Testing Site: Fully Anechoic Room (FAR); CETECOM Essen

Fri 04/Feb/2011 16:57:37ppf

Spurious Emissions V7.2.5

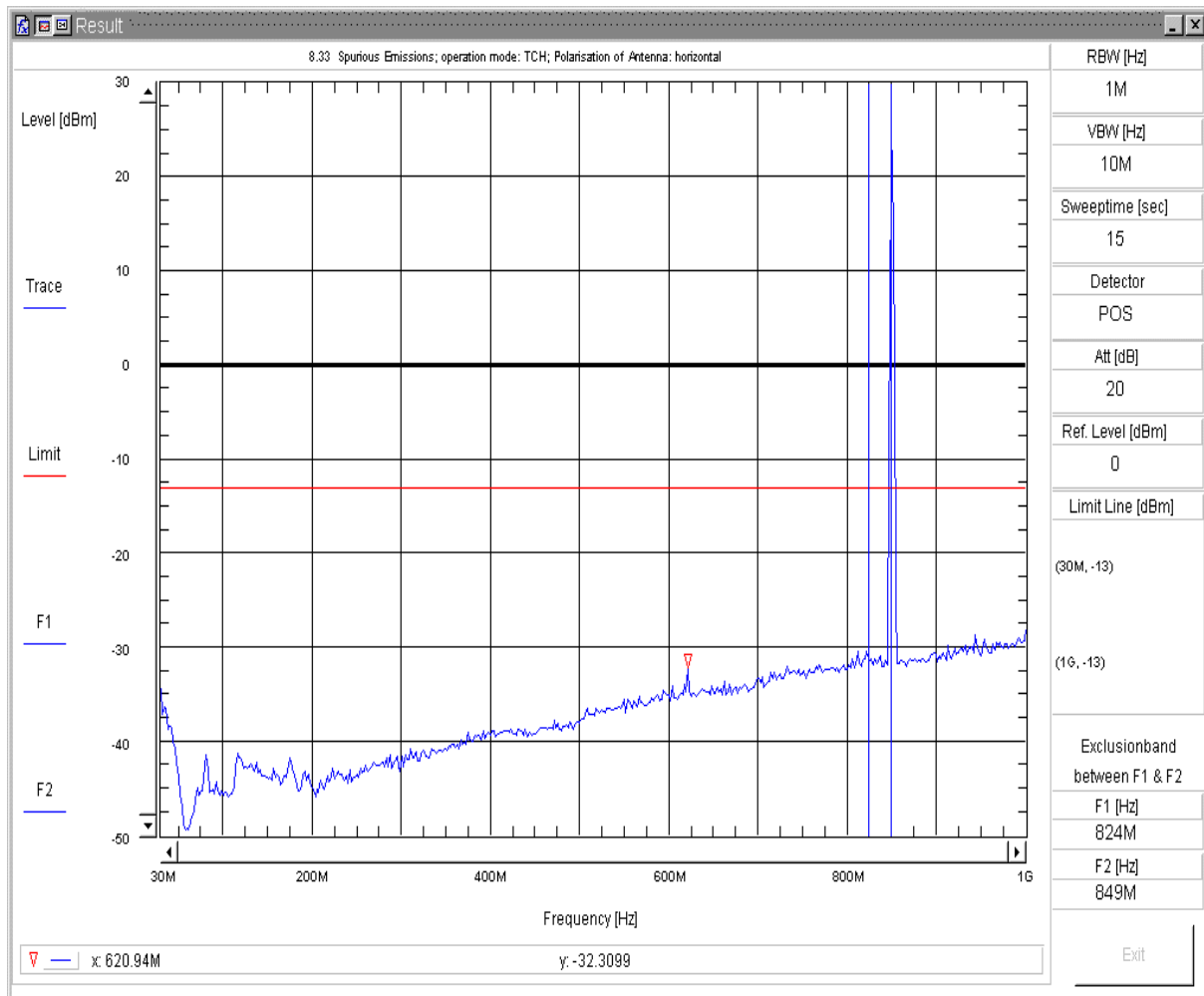

8.33 Radiated Spurious Emission

Transducer: c:\vee_user\spuri_V7\FCC_Part_22.917_(GSM_850)\TD_TX_H
 Sweepnr: Sweep1
 Pol. of Antenna: horizontal
 EUT Position: EUT_vertical+horizontal
 EUT OP Mode: FCC_Part_22.917_(GSM_850) TCH
 EUT Description: BGS2-W GSM Module
 EUT add. Info:
 EUT Hardware: B2
 EUT Software:
 EUT Config:
 EUT S/N: 00440108048446800
 Battery: Power Supply (external); Maximum Voltage; 4.5 VDC
 Remark: ARFCN 251
 Operator: Tas
 Testing Site: Fully Anechoic Room (FAR); CETECOM Essen

Fri 04/Feb/2011 17:07:36pff

Spurious Emissions V7.2.5

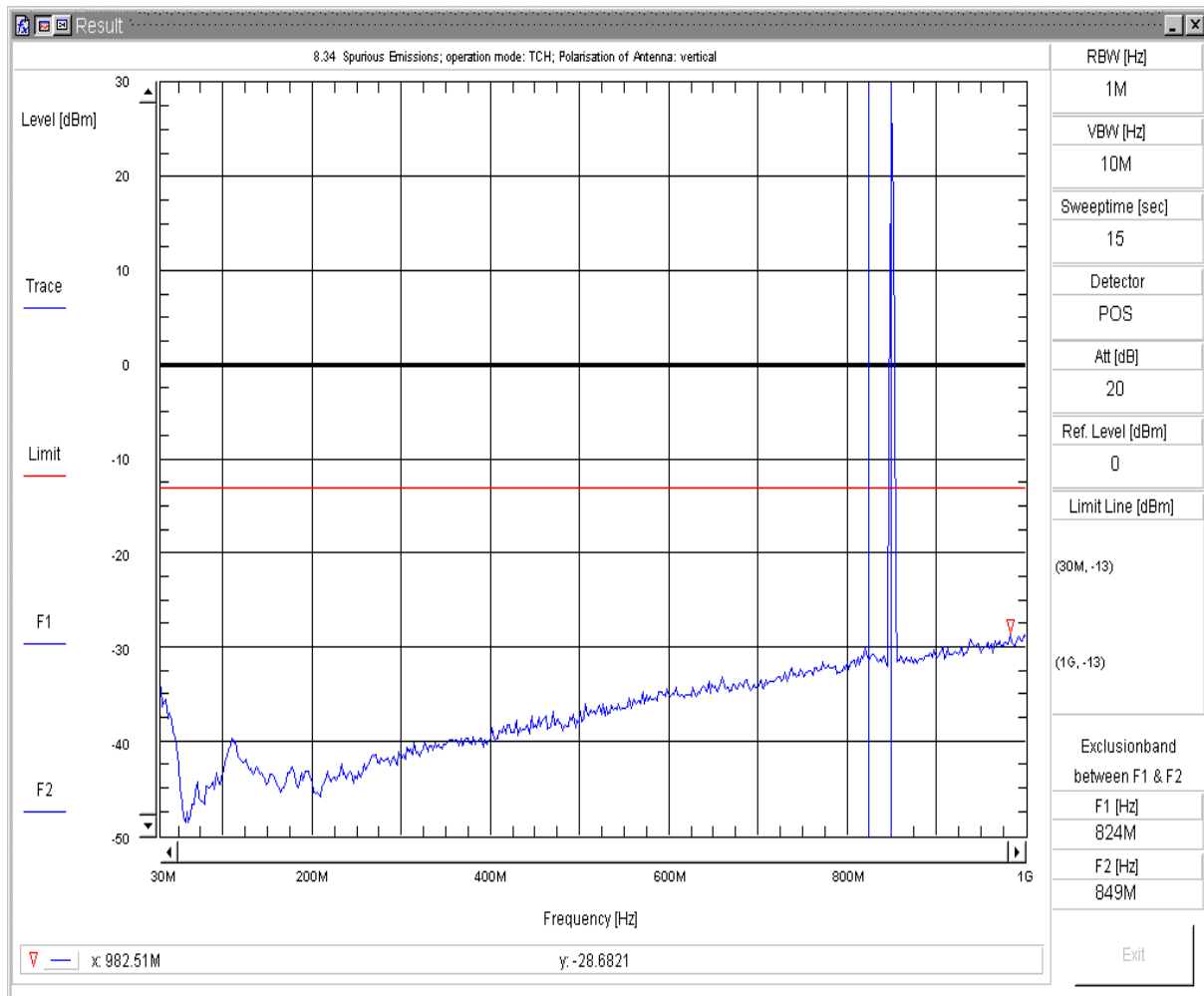

8.34 Radiated Spurious Emission

Transducer: c:\vee_user\spuri_V7\FCC_Part_22.917_(GSM_850)\TD_TX_V
 Sweepnr: Sweep1
 Pol. of Antenna: vertikal
 EUT Position: EUT_vertical+horizontal
 EUT OP Mode: FCC_Part_22.917_(GSM_850) TCH
 EUT Description: BGS2-W GSM Module
 EUT add. Info:
 EUT Hardware: B2
 EUT Software:
 EUT Config:
 EUT S/N: 00440108048446800
 Battery: Power Supply (external); Maximum Voltage; 4.5 VDC
 Remark: ARFCN 251
 Operator: Tas
 Testing Site: Fully Anechoic Room (FAR); CETECOM Essen

Fri 04/Feb/2011 17:03:23ppf

Spurious Emissions V7.2.5

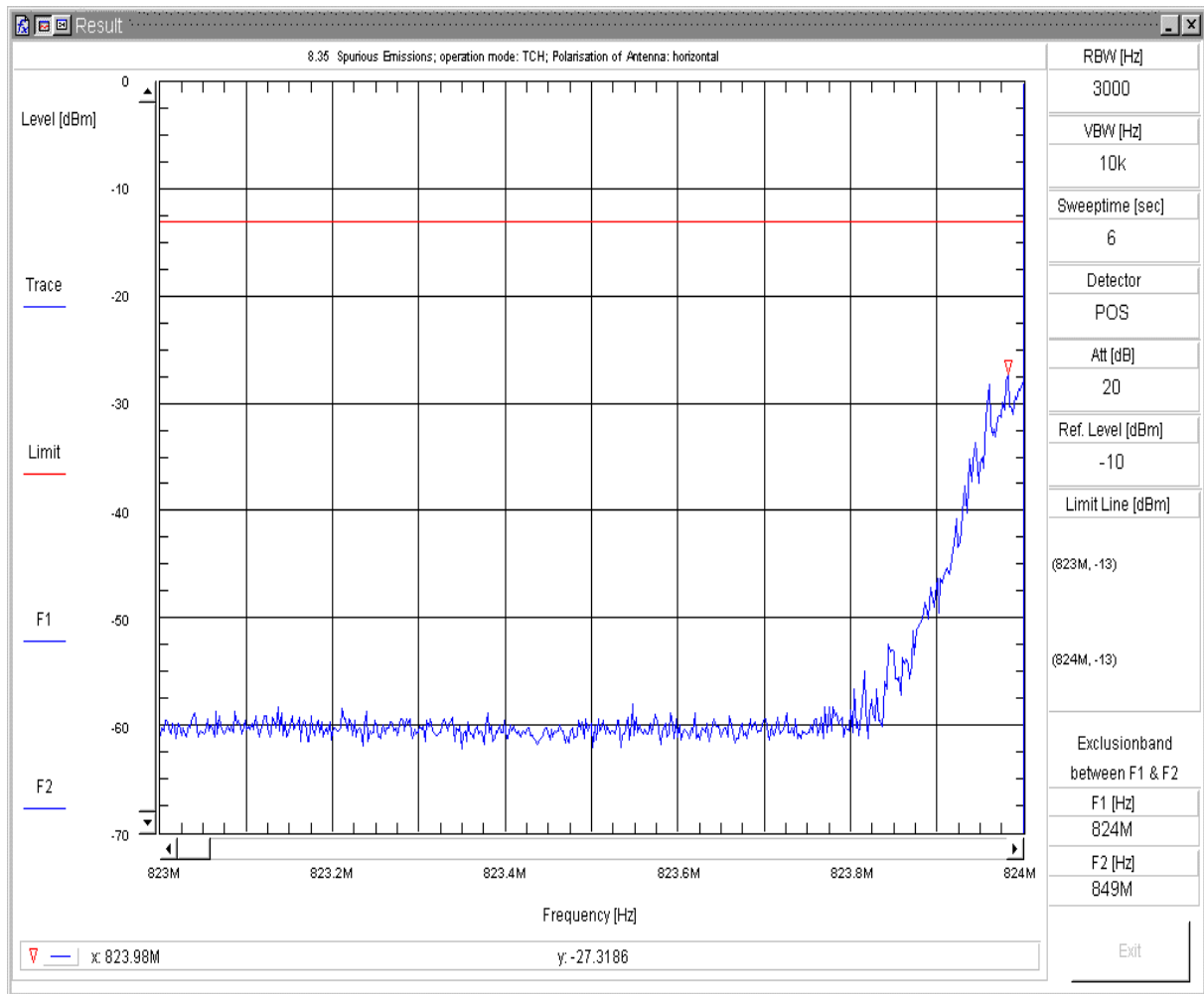

8.35 Radiated Spurious Emission

Transducer: c:\vee_user\spuri_V7\FCC_Part_22.917_(GSM_850)\TD_TX_H
 Sweepnr: Sweep2
 Pol. of Antenna: horizontal
 EUT Position: EUT_vertical+horizontal
 EUT OP Mode: FCC_Part_22.917_(GSM_850) TCH
 EUT Description: BGS2-W GSM Module
 EUT add. Info:
 EUT Hardware: B2
 EUT Software:
 EUT Config:
 EUT S/N: 00440108048446800
 Battery: Power Supply (external); Maximum Voltage; 4.5 VDC
 Remark: ARFCN 128
 Operator: Tas
 Testing Site: Fully Anechoic Room (FAR); CETECOM Essen

Fri 04/Feb/2011 15:36:05pff

Spurious Emissions V7.2.5

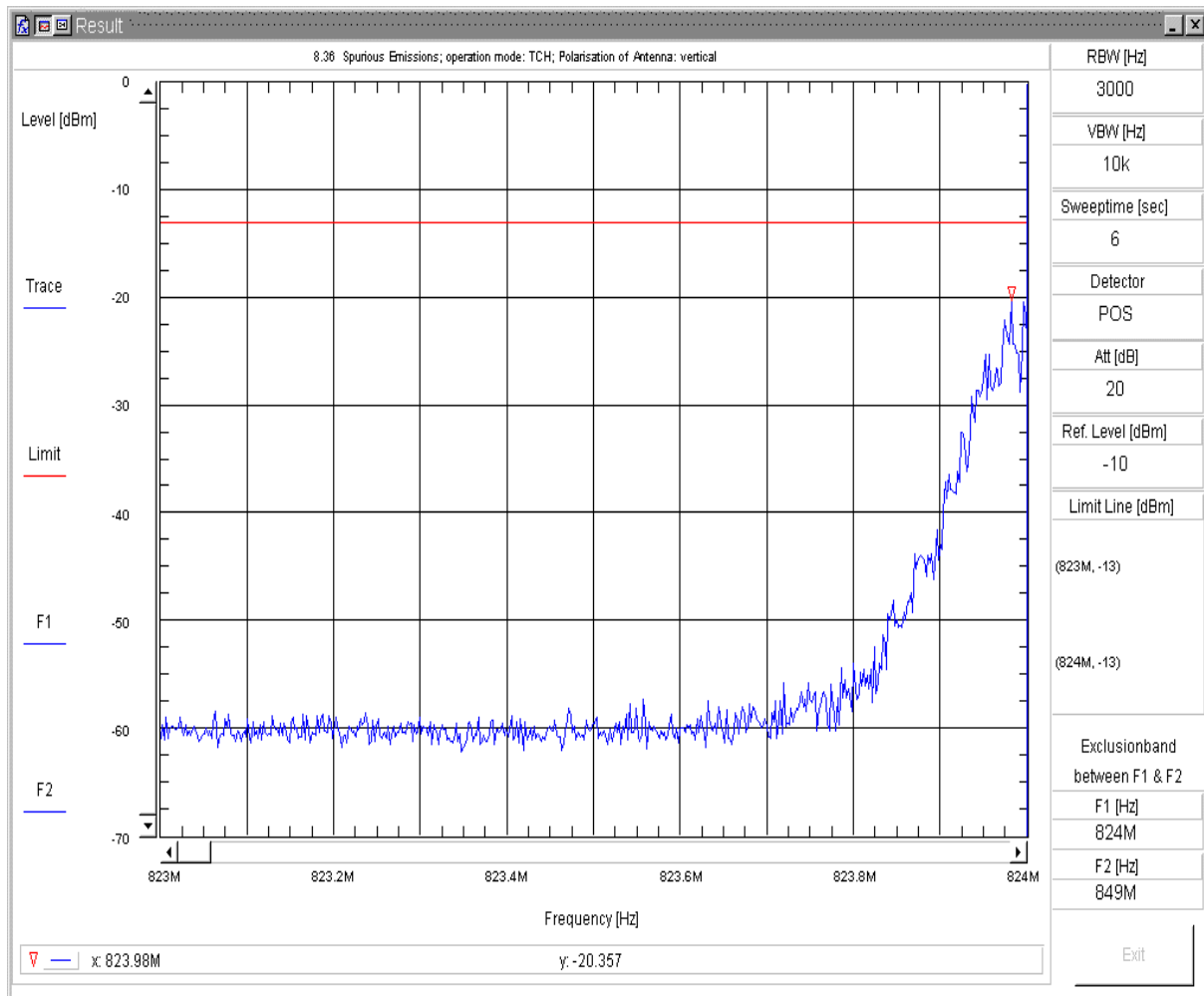

8.36 Radiated Spurious Emission

Transducer: c:\vee_user\spuri_V7\FCC_Part_22.917_(GSM_850)\TD_TX_V
 Sweepnr: Sweep2
 Pol. of Antenna: vertikal
 EUT Position: EUT_vertical+horizontal
 EUT OP Mode: FCC_Part_22.917_(GSM_850) TCH
 EUT Description: BGS2-W GSM Module
 EUT add. Info:
 EUT Hardware: B2
 EUT Software:
 EUT Config:
 EUT S/N: 00440108048446800
 Battery: Power Supply (external); Maximum Voltage; 4.5 VDC
 Remark: ARFCN 128
 Operator: Tas
 Testing Site: Fully Anechoic Room (FAR); CETECOM Essen

Fri 04/Feb/2011 15:32:23ppf

Spurious Emissions V7.2.5

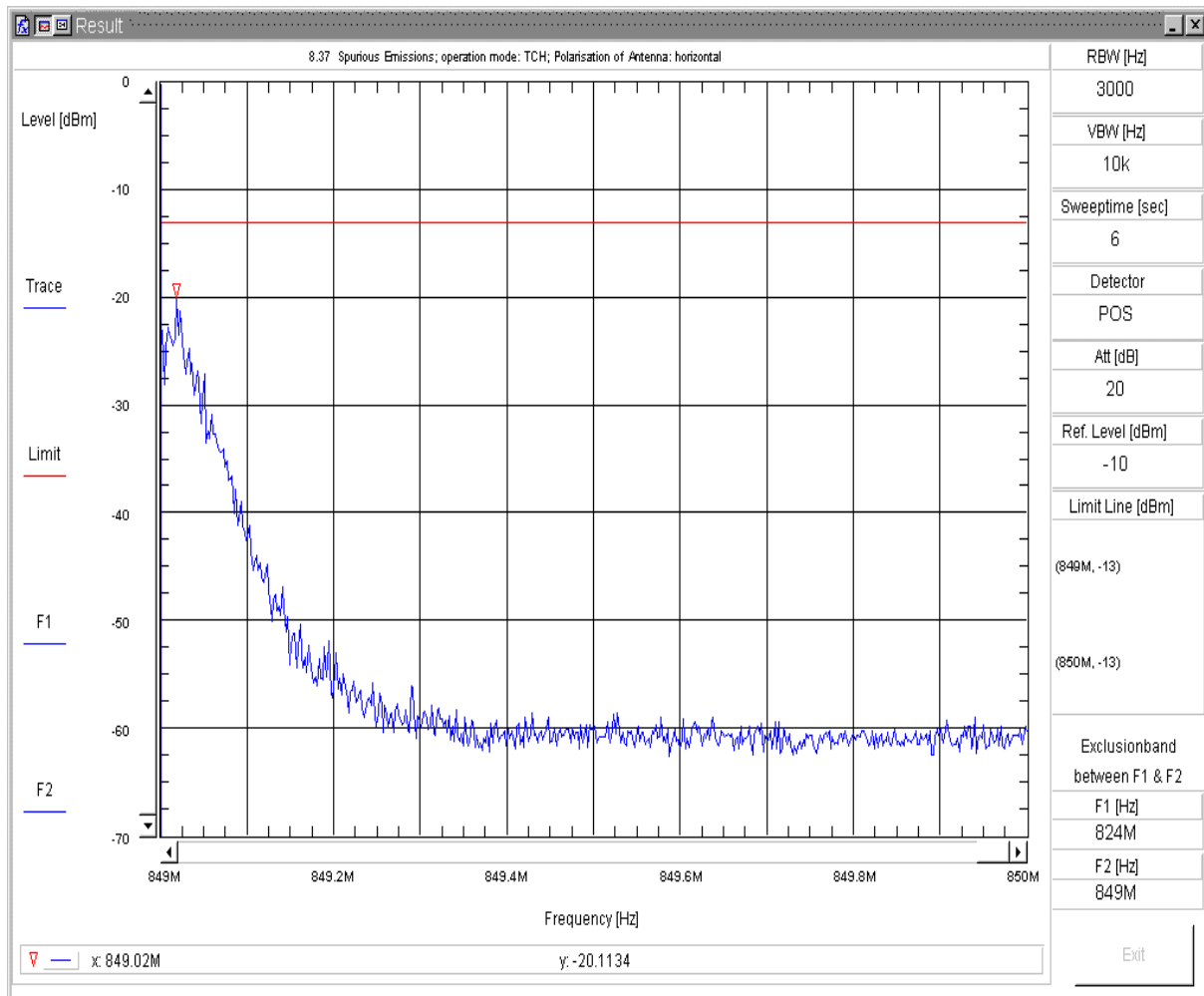

8.37 Radiated Spurious Emission

Transducer: c:\vee_user\spuri_V7\FCC_Part_22.917_(GSM_850)\TD_TX_H
 Sweepnr: Sweep3
 Pol. of Antenna: horizontal
 EUT Position: EUT_vertical+horizontal
 EUT OP Mode: FCC_Part_22.917_(GSM_850) TCH
 EUT Description: BGS2-W GSM Module
 EUT add. Info:
 EUT Hardware: B2
 EUT Software:
 EUT Config:
 EUT S/N: 00440108048446800
 Battery: Power Supply (external); Maximum Voltage; 4.5 VDC
 Remark: ARFCN 251
 Operator: Tas
 Testing Site: Fully Anechoic Room (FAR); CETECOM Essen

Fri 04/Feb/2011 17:11:56pff

Spurious Emissions V7.2.5

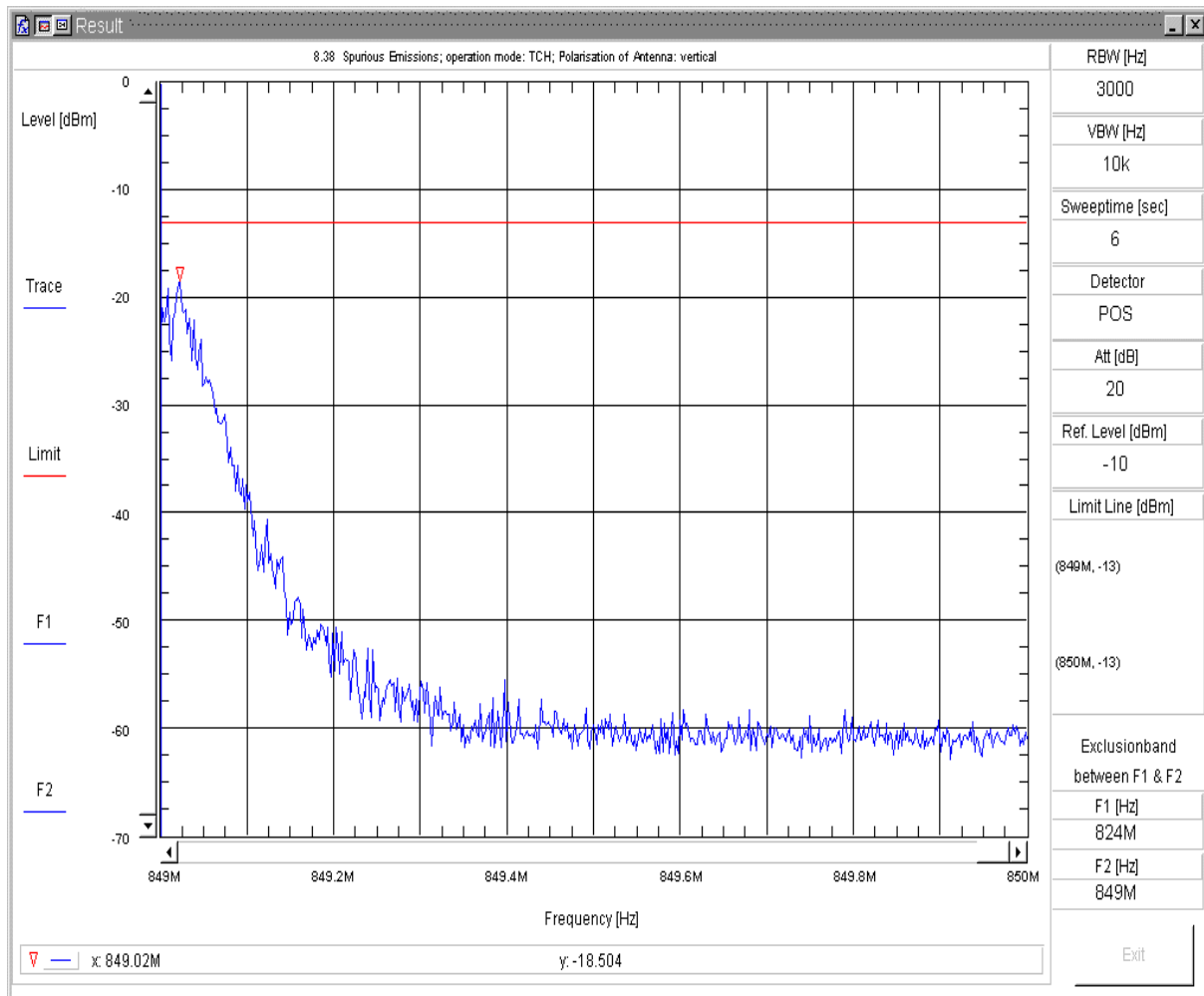

8.38 Radiated Spurious Emission

Transducer: c:\vee_user\spuri_V7\FCC_Part_22.917_(GSM_850)\TD_TX_V
 Sweepnr: Sweep3
 Pol. of Antenna: vertikal
 EUT Position: EUT_vertical+horizontal
 EUT OP Mode: FCC_Part_22.917_(GSM_850) TCH
 EUT Description: BGS2-W GSM Module
 EUT add. Info:
 EUT Hardware: B2
 EUT Software:
 EUT Config:
 EUT S/N: 00440108048446800
 Battery: Power Supply (external); Maximum Voltage; 4.5 VDC
 Remark: ARFCN 251
 Operator: Tas
 Testing Site: Fully Anechoic Room (FAR); CETECOM Essen

Fri 04/Feb/2011 17:15:06ppf

Spurious Emissions V7.2.5

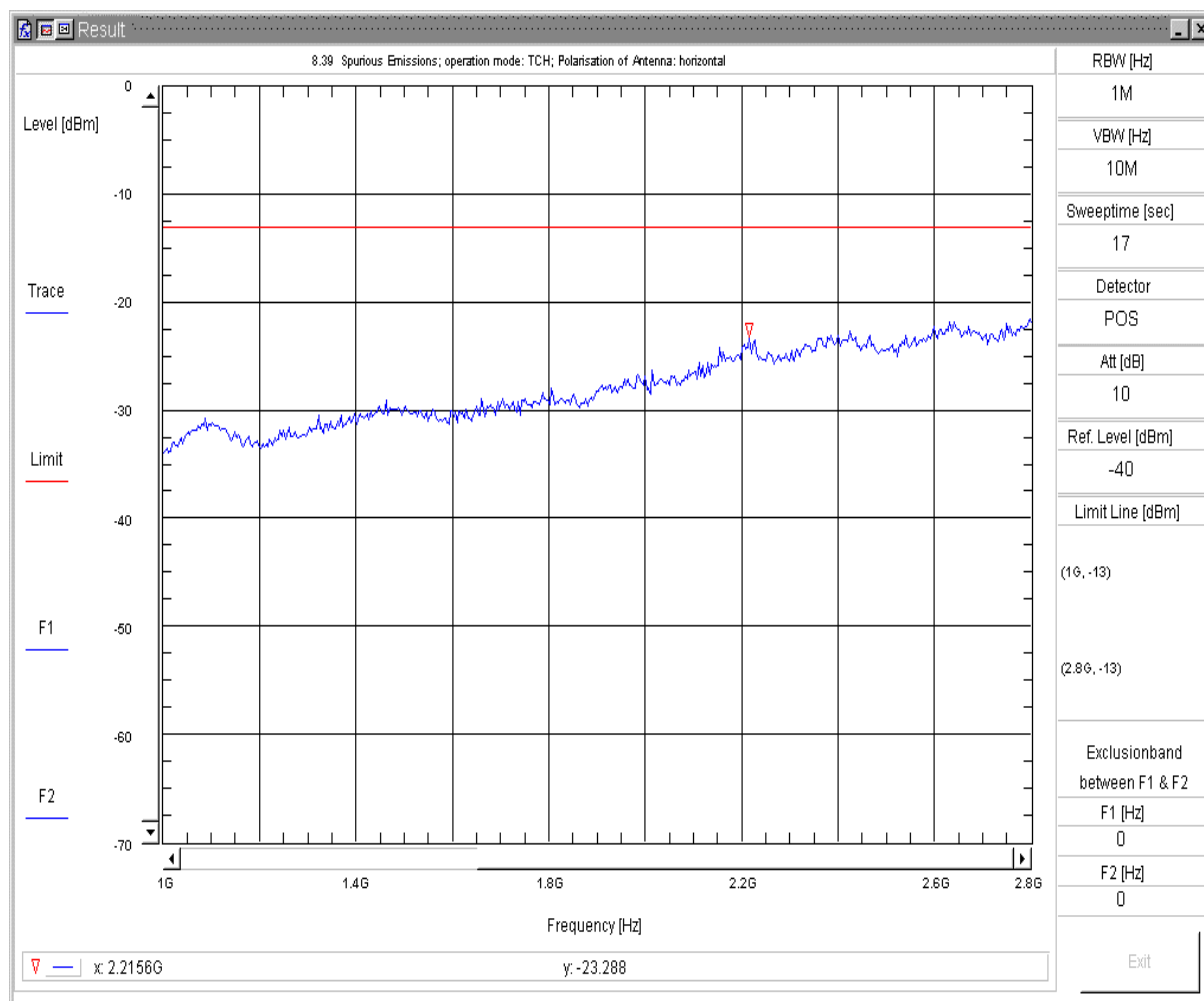

8.39 Radiated Spurious Emission

Transducer: c:\vee_user\spuri_V7\FCC_Part_22.917_(GSM_850)\TD_TX_H
 Sweepnr: Sweep4
 Pol. of Antenna: horizontal
 EUT Position: EUT_vertical+horizontal
 EUT OP Mode: FCC_Part_22.917_(GSM_850) TCH
 EUT Description: BGS2-W GSM Module
 EUT add. Info:
 EUT Hardware: B2
 EUT Software:
 EUT Config:
 EUT S/N: 00440108048446800
 Battery: Power Supply (external); Maximum Voltage; 4.5 VDC
 Remark: ARFCN 128
 Operator: Tas
 Testing Site: Fully Anechoic Room (FAR); CETECOM Essen

Fri 04/Feb/2011 15:40:23fp

Spurious Emissions V7.2.5

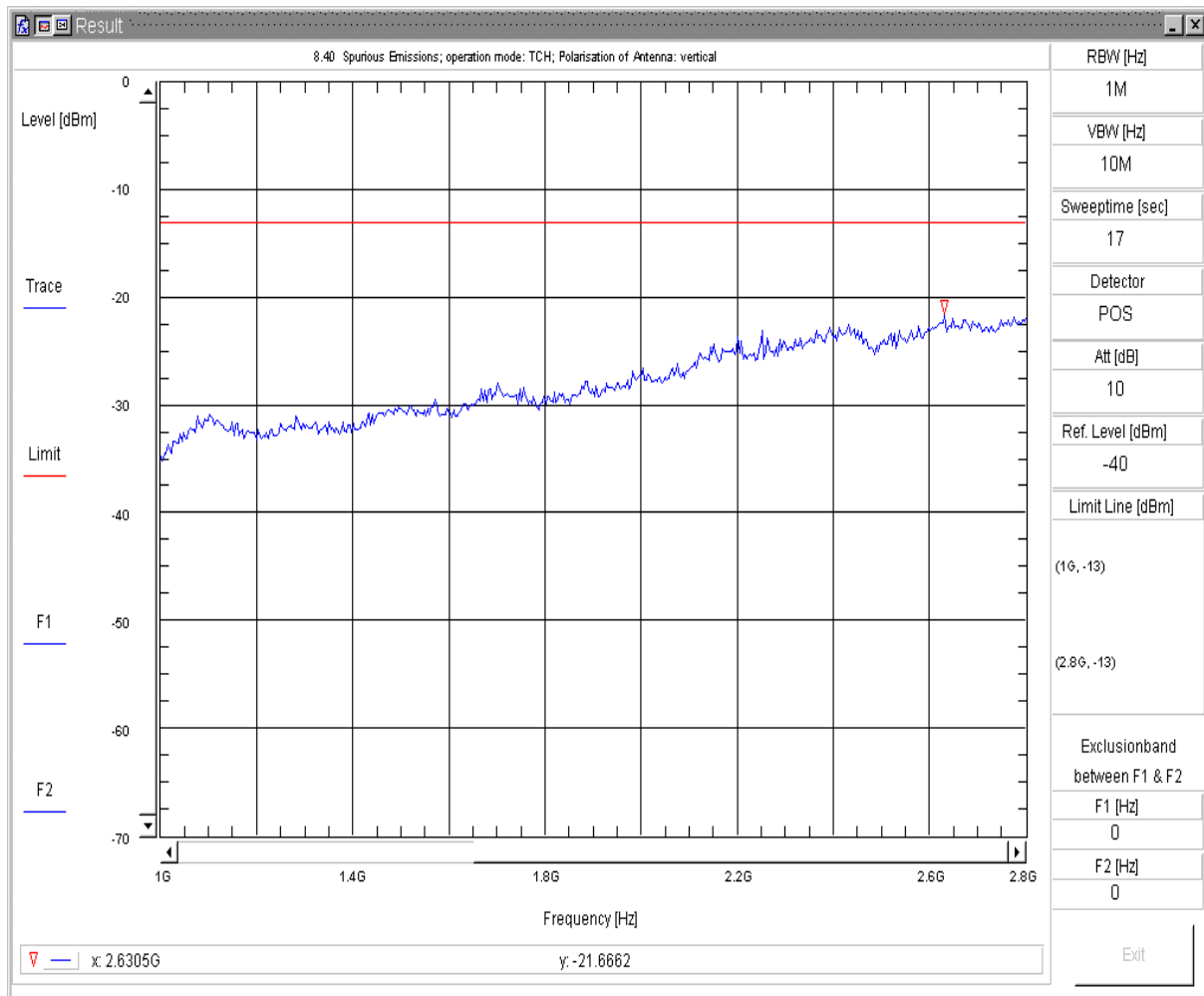

8.40 Radiated Spurious Emission

Transducer: c:\vee_user\spuri_V7\FCC_Part_22.917_(GSM_850)\TD_TX_V
 Sweepnr: Sweep4
 Pol. of Antenna: vertikal
 EUT Position: EUT_vertical+horizontal
 EUT OP Mode: FCC_Part_22.917_(GSM_850) TCH
 EUT Description: BGS2-W GSM Module
 EUT add. Info:
 EUT Hardware: B2
 EUT Software:
 EUT Config:
 EUT S/N: 00440108048446800
 Battery: Power Supply (external); Maximum Voltage; 4.5 VDC
 Remark: ARFCN 128
 Operator: Tas
 Testing Site: Fully Anechoic Room (FAR); CETECOM Essen

Fri 04/Feb/2011 15:48:00pp

Spurious Emissions V7.2.5

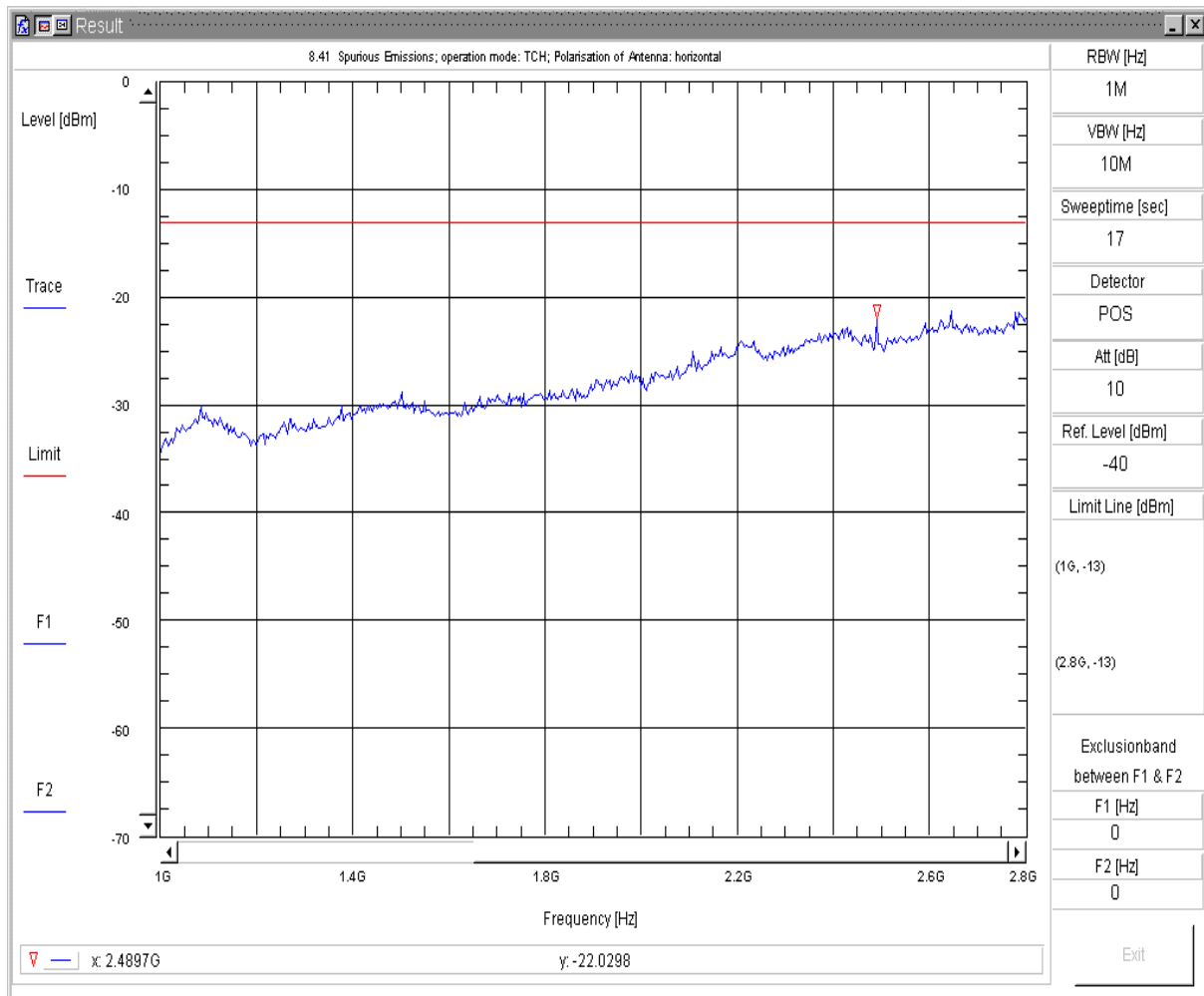

8.41 Radiated Spurious Emission

Transducer: c:\vee_user\spuri_V7\FCC_Part_22.917_(GSM_850)\TD_TX_H
 Sweepnr: Sweep4
 Pol. of Antenna: horizontal
 EUT Position: EUT_vertical+horizontal
 EUT OP Mode: FCC_Part_22.917_(GSM_850) TCH
 EUT Description: BGS2-W GSM Module
 EUT add. Info:
 EUT Hardware: B2
 EUT Software:
 EUT Config:
 EUT S/N: 00440108048446800
 Battery: Power Supply (external); Maximum Voltage; 4.5 VDC
 Remark: ARFCN 192
 Operator: Tas
 Testing Site: Fully Anechoic Room (FAR); CETECOM Essen

Fri 04/Feb/2011 16:42:52fp

Spurious Emissions V7.2.5

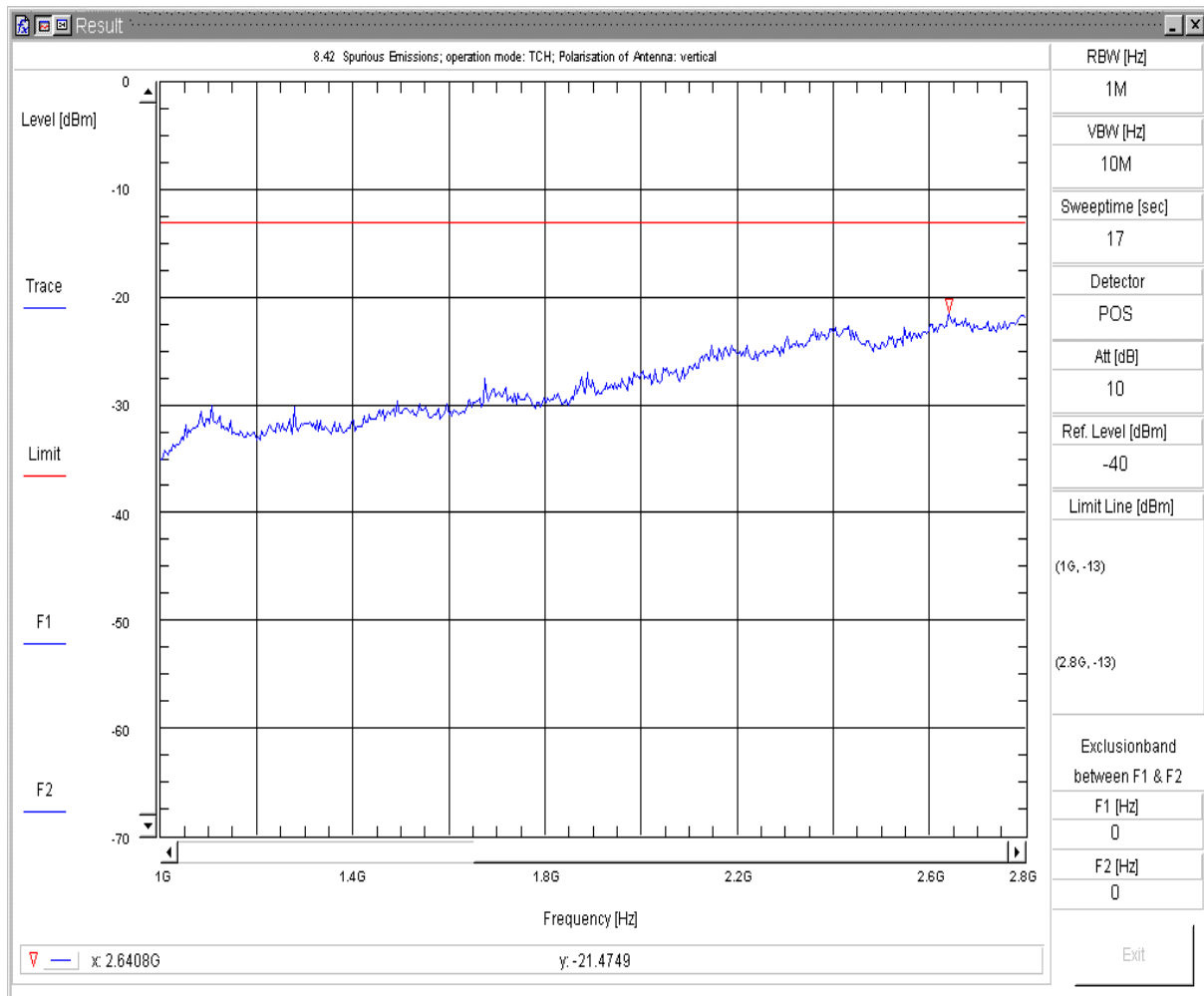

8.42 Radiated Spurious Emission

Transducer: c:\vee_user\spuri_V7\FCC_Part_22.917_(GSM_850)\TD_TX_V
 Sweepnr: Sweep4
 Pol. of Antenna: vertikal
 EUT Position: EUT_vertical+horizontal
 EUT OP Mode: FCC_Part_22.917_(GSM_850) TCH
 EUT Description: BGS2-W GSM Module
 EUT add. Info:
 EUT Hardware: B2
 EUT Software:
 EUT Config:
 EUT S/N: 00440108048446800
 Battery: Power Supply (external); Maximum Voltage; 4.5 VDC
 Remark: ARFCN 192
 Operator: Tas
 Testing Site: Fully Anechoic Room (FAR); CETECOM Essen

Fri 04/Feb/2011 16:35:46pp

Spurious Emissions V7.2.5

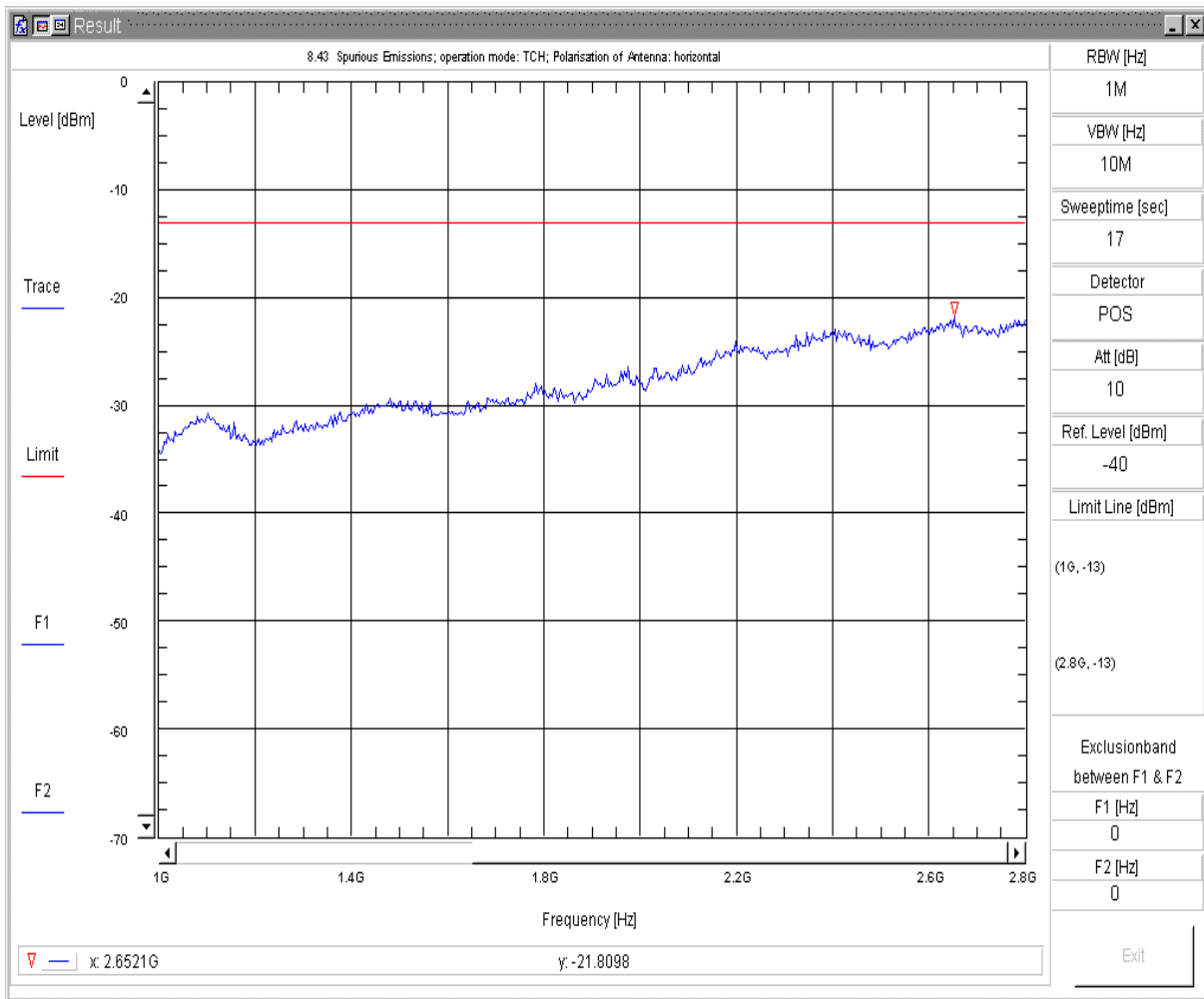

8.43 Radiated Spurious Emission

Transducer: c:\vee_user\spuri_V7\FCC_Part_22.917_(GSM_850)\TD_TX_H
 Sweepnr: Sweep4
 Pol. of Antenna: horizontal
 EUT Position: EUT_vertical+horizontal
 EUT OP Mode: FCC_Part_22.917_(GSM_850) TCH
 EUT Description: BGS2-W GSM Module
 EUT add. Info:
 EUT Hardware: B2
 EUT Software:
 EUT Config:
 EUT S/N: 00440108048446800
 Battery: Power Supply (external); Maximum Voltage; 4.5 VDC
 Remark: ARFCN 251
 Operator: Tas
 Testing Site: Fully Anechoic Room (FAR); CETECOM Essen

Fri 04/Feb/2011 17:25:13fp

Spurious Emissions V7.2.5

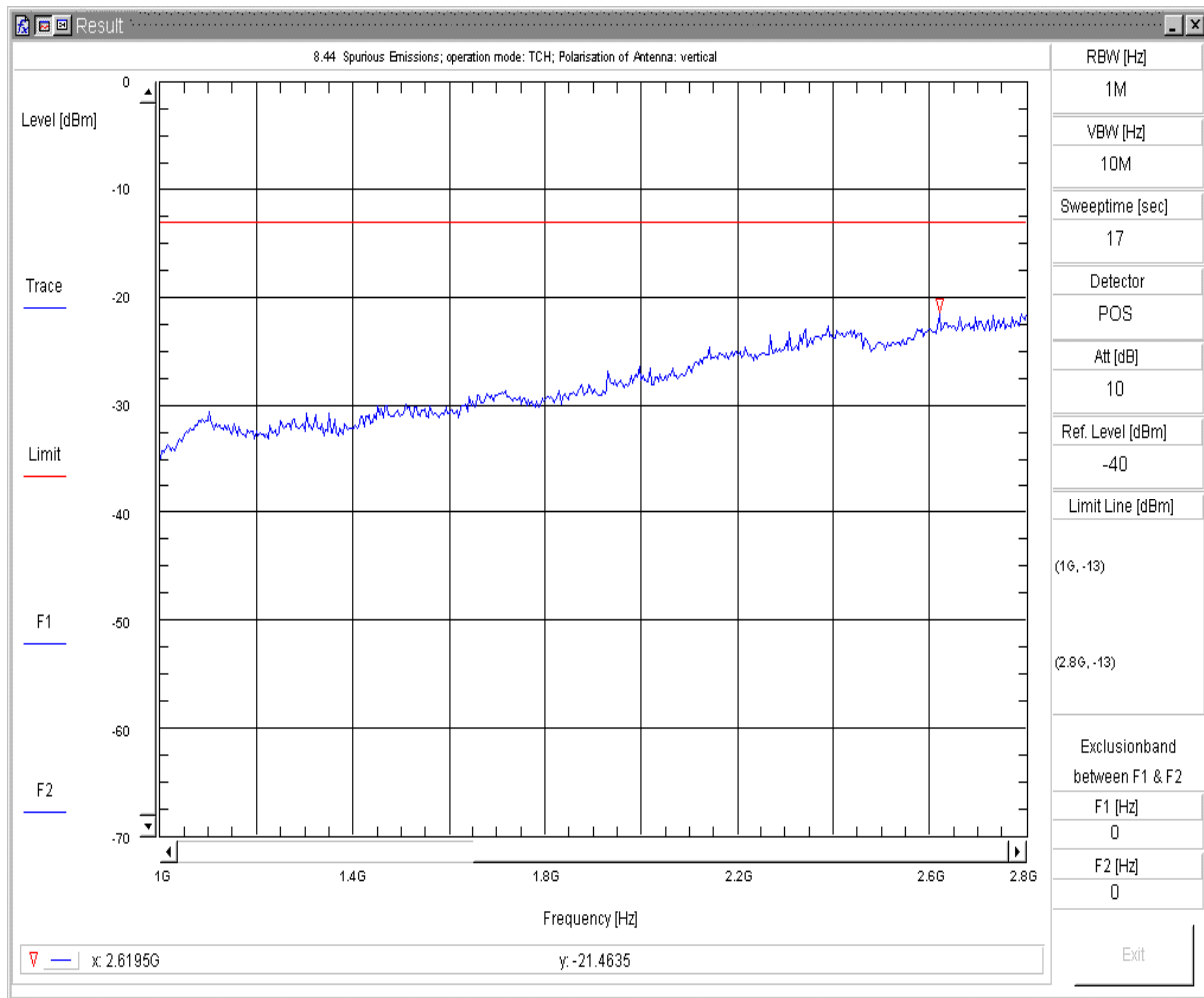

8.44 Radiated Spurious Emission

Transducer: c:\vee_user\spuri_V7\FCC_Part_22.917_(GSM_850)\TD_TX_V
 Sweepnr: Sweep4
 Pol. of Antenna: vertikal
 EUT Position: EUT_vertical+horizontal
 EUT OP Mode: FCC_Part_22.917_(GSM_850) TCH
 EUT Description: BGS2-W GSM Module
 EUT add. Info:
 EUT Hardware: B2
 EUT Software:
 EUT Config:
 EUT S/N: 00440108048446800
 Battery: Power Supply (external); Maximum Voltage; 4.5 VDC
 Remark: ARFCN 251
 Operator: Tas
 Testing Site: Fully Anechoic Room (FAR); CETECOM Essen

Fri 04/Feb/2011 17:18:24pp

Spurious Emissions V7.2.5

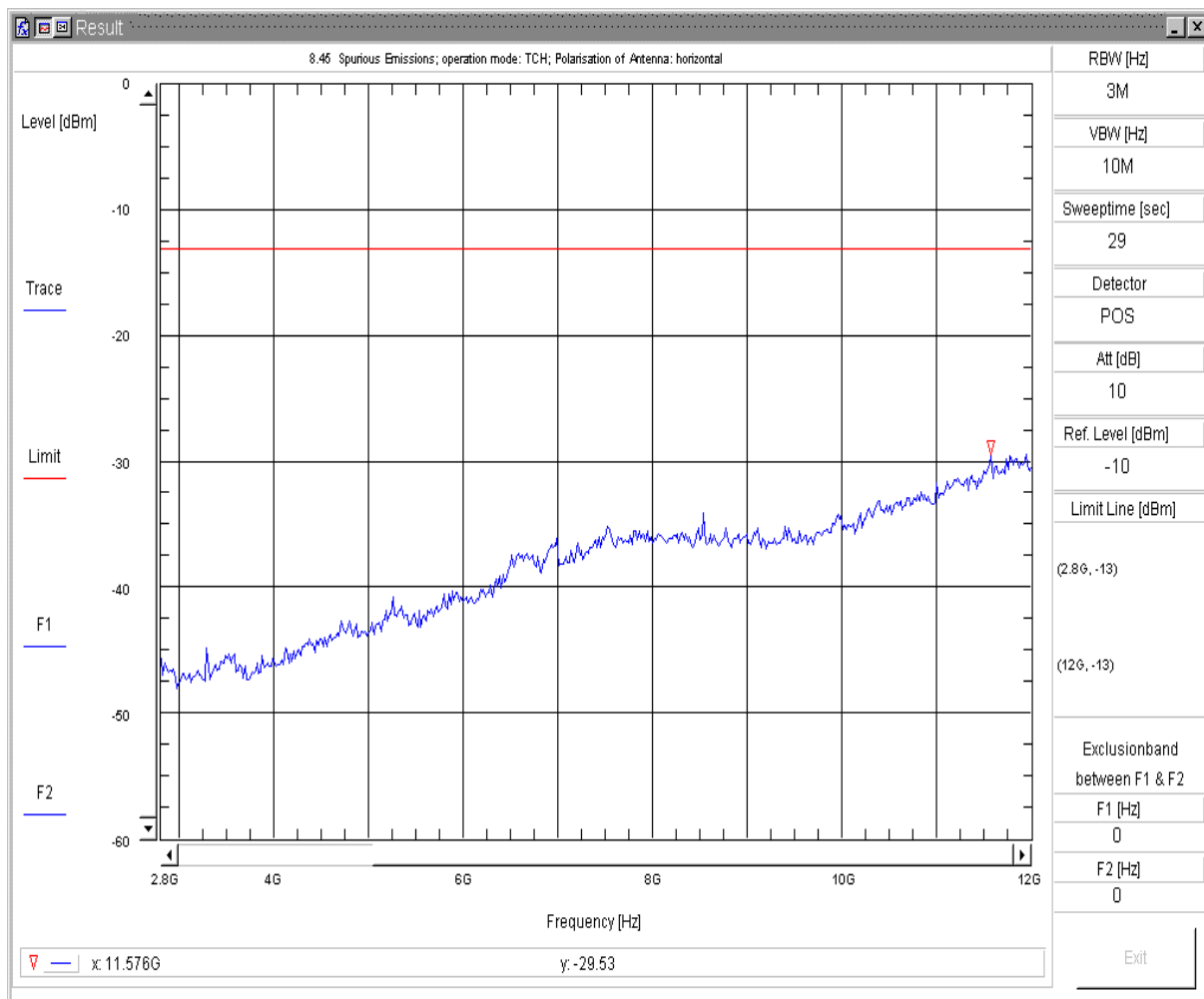

8.45 Radiated Spurious Emission

Transducer: c:\vee_user\spuri_V7\FCC_Part_22.917_(GSM_850)\TD_TX_H
 Sweepnr: Sweep5
 Pol. of Antenna: horizontal
 EUT Position: EUT_vertical+horizontal
 EUT OP Mode: FCC_Part_22.917_(GSM_850) TCH
 EUT Description: BGS2-W GSM Module
 EUT add. Info:
 EUT Hardware: B2
 EUT Software:
 EUT Config:
 EUT S/N: 00440108048446800
 Battery: Power Supply (external); Maximum Voltage; 4.5 VDC
 Remark: ARFCN 128
 Operator: Tas
 Testing Site: Fully Anechoic Room (FAR); CETECOM Essen

Fri 04/Feb/2011 16:05:15pf

Spurious Emissions V7.2.5

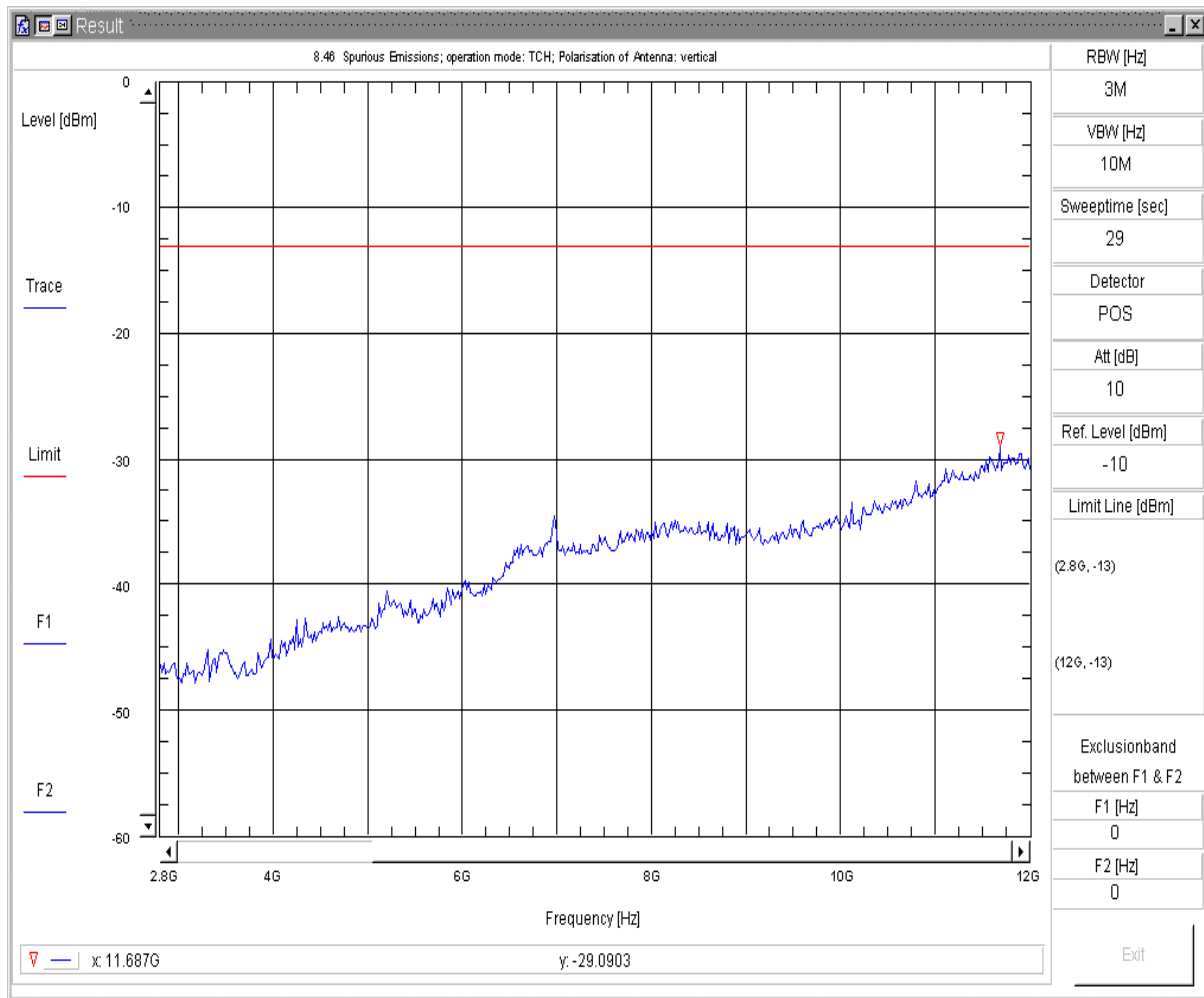

8.46 Radiated Spurious Emission

Transducer: c:\vee_user\spuri_V7\FCC_Part_22.917_(GSM_850)\TD_TX_V
 Sweepnr: Sweep5
 Pol. of Antenna: vertikal
 EUT Position: EUT_vertical+horizontal
 EUT OP Mode: FCC_Part_22.917_(GSM_850) TCH
 EUT Description: BGS2-W GSM Module
 EUT add. Info:
 EUT Hardware: B2
 EUT Software:
 EUT Config:
 EUT S/N: 00440108048446800
 Battery: Power Supply (external); Maximum Voltage; 4.5 VDC
 Remark: ARFCN 128
 Operator: Tas
 Testing Site: Fully Anechoic Room (FAR); CETECOM Essen

Fri 04/Feb/2011 15:55:25fp

Spurious Emissions V7.2.5

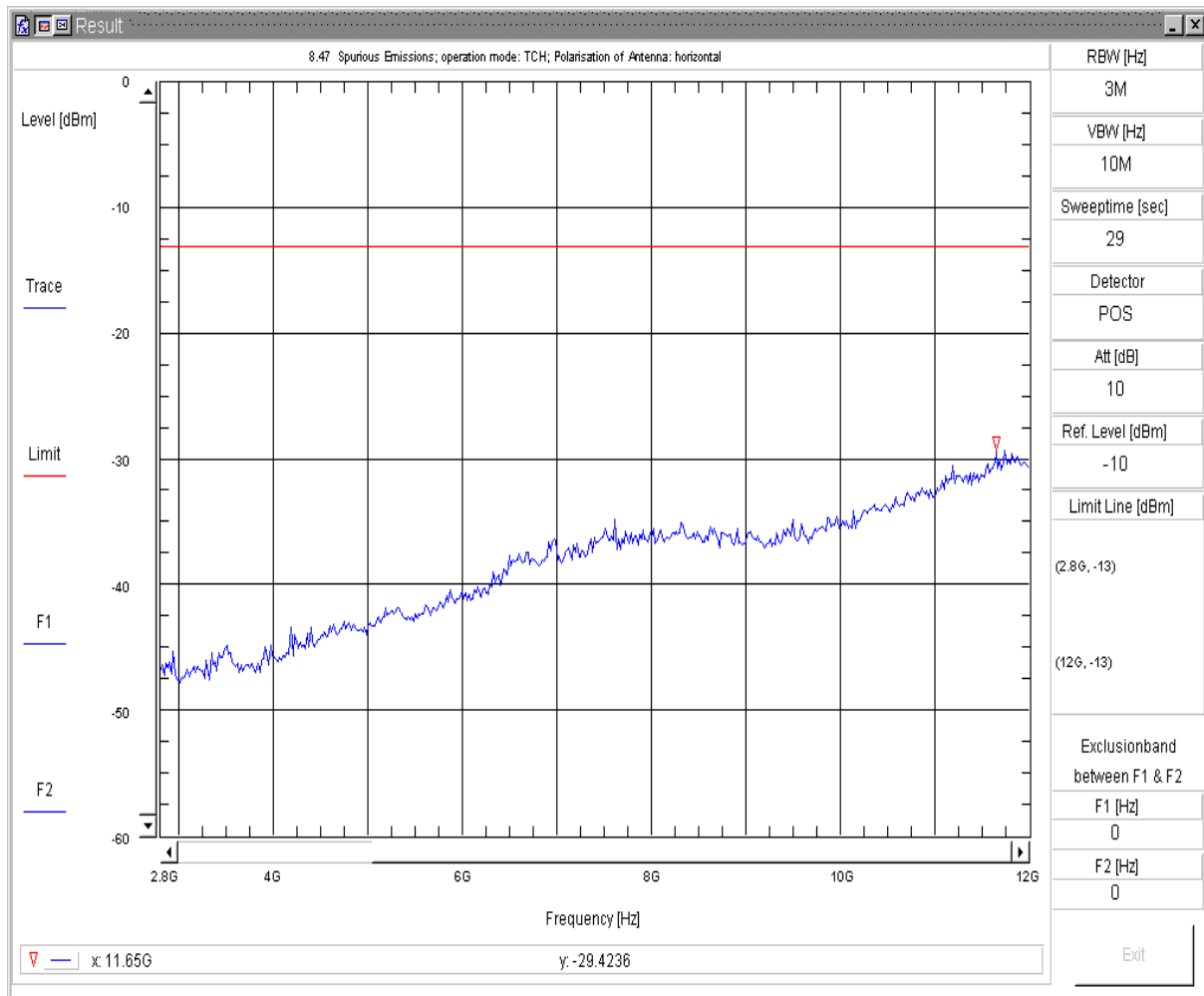

8.47 Radiated Spurious Emission

Transducer: c:\vee_user\spuri_V7\FCC_Part_22.917_(GSM_850)\TD_TX_H
 Sweepnr: Sweep5
 Pol. of Antenna: horizontal
 EUT Position: EUT_vertical+horizontal
 EUT OP Mode: FCC_Part_22.917_(GSM_850) TCH
 EUT Description: BGS2-W GSM Module
 EUT add. Info:
 EUT Hardware: B2
 EUT Software:
 EUT Config:
 EUT S/N: 00440108048446800
 Battery: Power Supply (external); Maximum Voltage; 4.5 VDC
 Remark: ARFCN 192
 Operator: Tas
 Testing Site: Fully Anechoic Room (FAR); CETECOM Essen

Fri 04/Feb/2011 16:15:56pp

Spurious Emissions V7.2.5

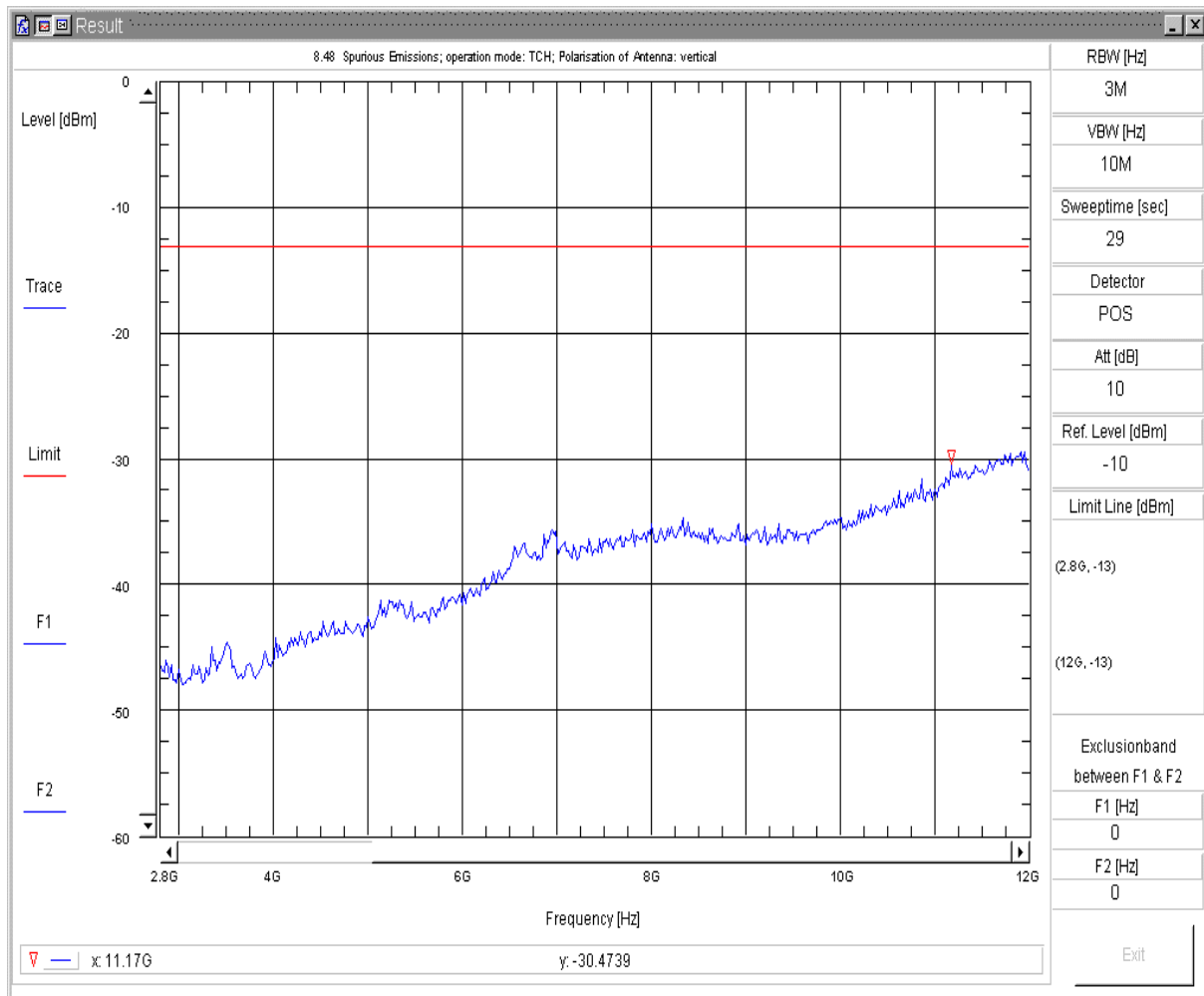

8.48 Radiated Spurious Emission

Transducer: c:\vee_user\spuri_V7\FCC_Part_22.917_(GSM_850)\TD_TX_V
 Sweepnr: Sweep5
 Pol. of Antenna: vertikal
 EUT Position: EUT_vertical+horizontal
 EUT OP Mode: FCC_Part_22.917_(GSM_850) TCH
 EUT Description: BGS2-W GSM Module
 EUT add. Info:
 EUT Hardware: B2
 EUT Software:
 EUT Config:
 EUT S/N: 00440108048446800
 Battery: Power Supply (external); Maximum Voltage; 4.5 VDC
 Remark: ARFCN 192
 Operator: Tas
 Testing Site: Fully Anechoic Room (FAR); CETECOM Essen

Fri 04/Feb/2011 16:25:32ff

Spurious Emissions V7.2.5

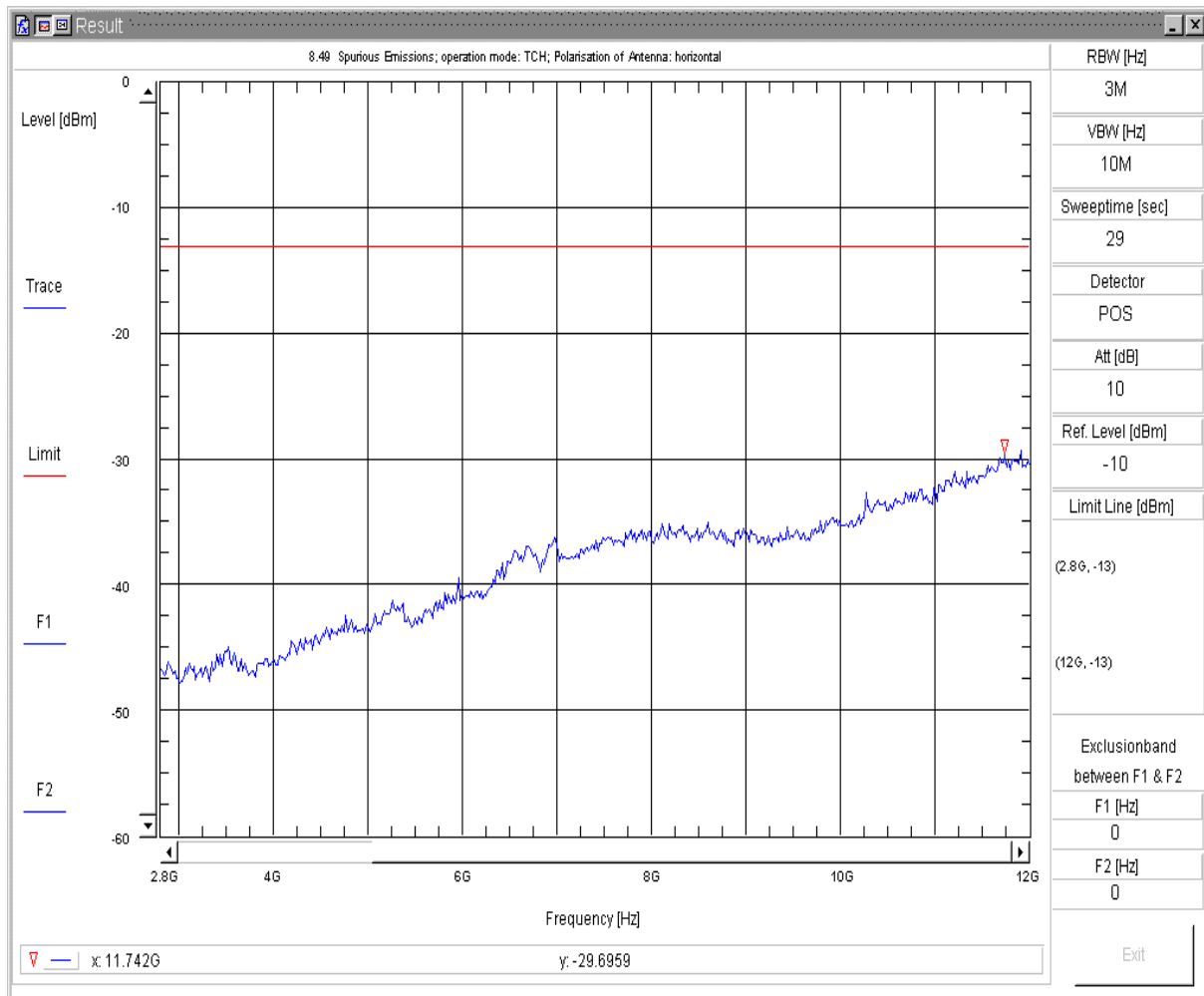

8.49 Radiated Spurious Emission

Transducer: c:\vee_user\spuri_V7\FCC_Part_22.917_(GSM_850)\TD_TX_H
 Sweepnr: Sweep5
 Pol. of Antenna: horizontal
 EUT Position: EUT_vertical+horizontal
 EUT OP Mode: FCC_Part_22.917_(GSM_850) TCH
 EUT Description: BGS2-W GSM Module
 EUT add. Info:
 EUT Hardware: B2
 EUT Software:
 EUT Config:
 EUT S/N: 00440108048446800
 Battery: Power Supply (external); Maximum Voltage; 4.5 VDC
 Remark: ARFCN 251
 Operator: Tas
 Testing Site: Fully Anechoic Room (FAR); CETECOM Essen

Fri 04/Feb/2011 17:32:48pf

Spurious Emissions V7.2.5

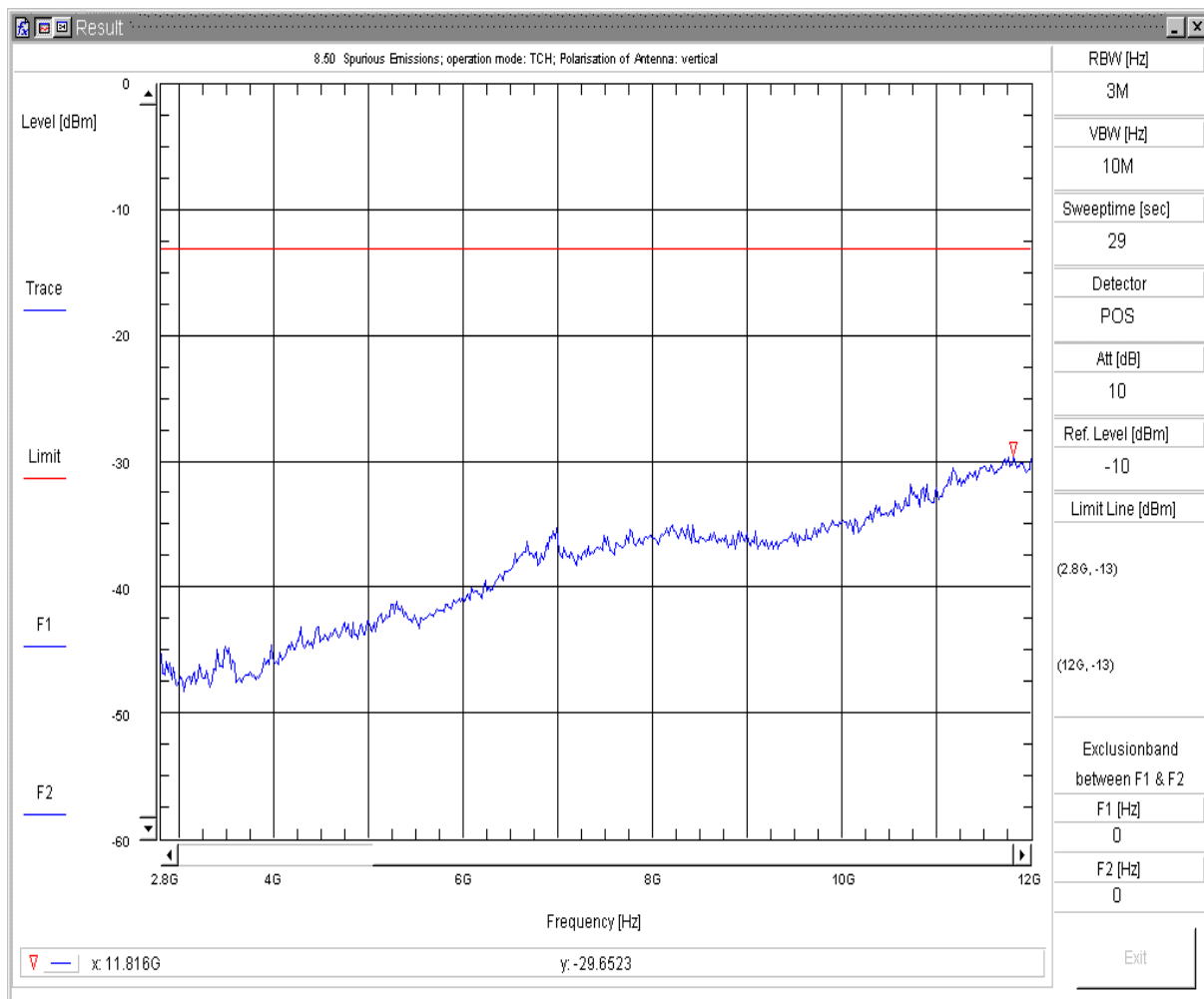

8.50 Radiated Spurious Emission

Transducer: c:\vee_user\spuri_V7\FCC_Part_22.917_(GSM_850)\TD_TX_V
 Sweepnr: Sweep5
 Pol. of Antenna: vertikal
 EUT Position: EUT_vertical+horizontal
 EUT OP Mode: FCC_Part_22.917_(GSM_850) TCH
 EUT Description: BGS2-W GSM Module
 EUT add. Info:
 EUT Hardware: B2
 EUT Software:
 EUT Config:
 EUT S/N: 00440108048446800
 Battery: Power Supply (external); Maximum Voltage; 4.5 VDC
 Remark: ARFCN 251
 Operator: Tas
 Testing Site: Fully Anechoic Room (FAR); CETECOM Essen

Fri 04/Feb/2011 17:42:37ff

Spurious Emissions V7.2.5

1.6. Spurious emissions radiated – GSM1900 Mode

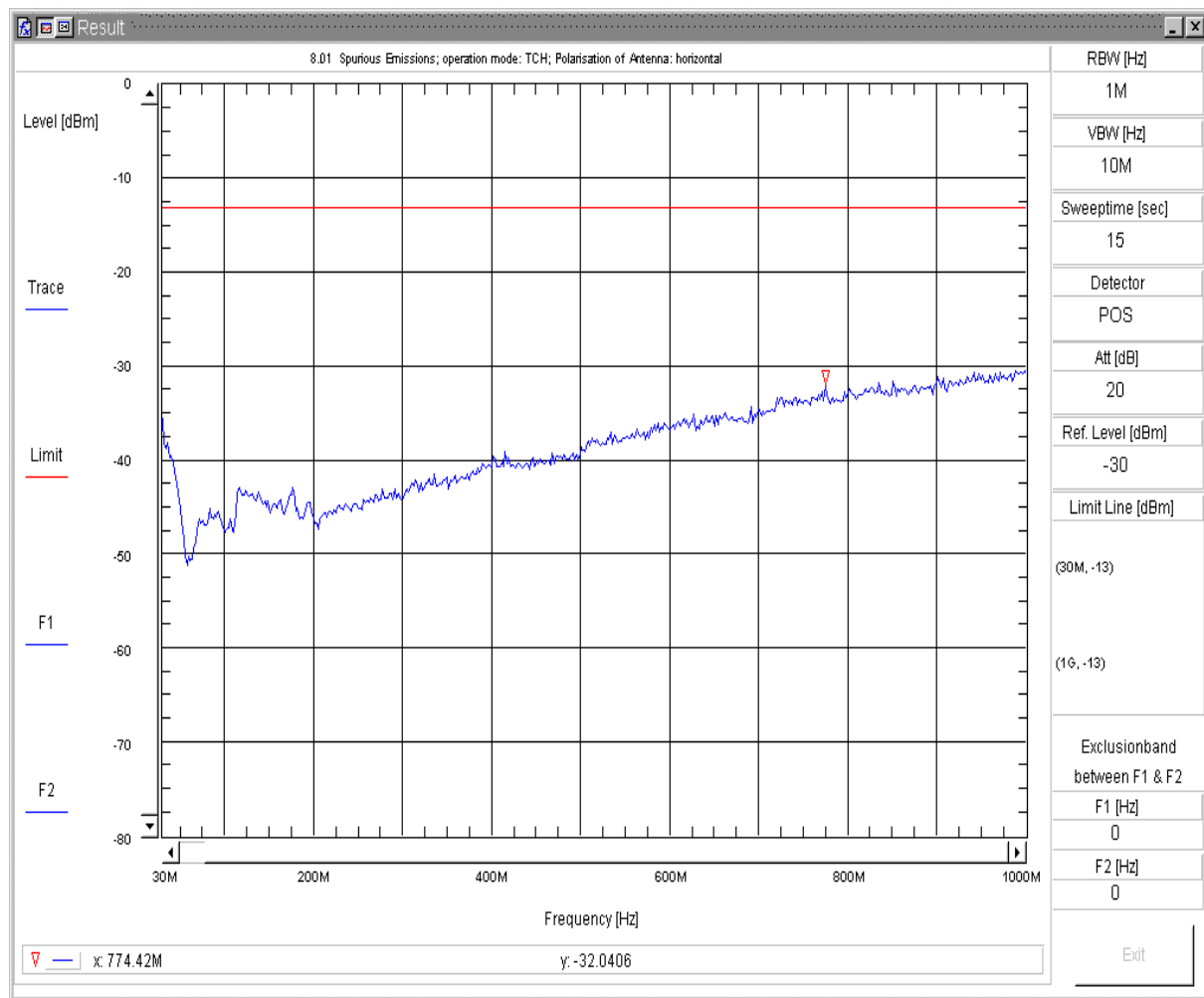

8.01 Radiated Spurious Emission

Transducer: c:\vee_user\spuri_V7\FCC_Part_24.238_(GSM_1900)\TD_TX_H
 Sweepnr: Sweep1
 Pol. of Antenna: horizontal
 EUT Position: EUT_vertical+horizontal
 EUT OP Mode: FCC_Part_24.238_(GSM_1900) TCH
 EUT Description: BGS2-W GSM Module
 EUT add. Info: DSB45+Adapter Board + Handset Votronic+RS232+USB-cable
 EUT Hardware: B2
 EUT Software:
 EUT Config:
 EUT S/N: 00440108048446800
 Battery: Power Supply (external); Maximum Voltage; 4.5 VDC
 Remark: channel 512
 Operator: Lor
 Testing Site: Fully Anechoic Room (FAR); CETECOM Essen

Fri 04/Feb/2011 09:24:14pff

Spurious Emissions V7.2.5

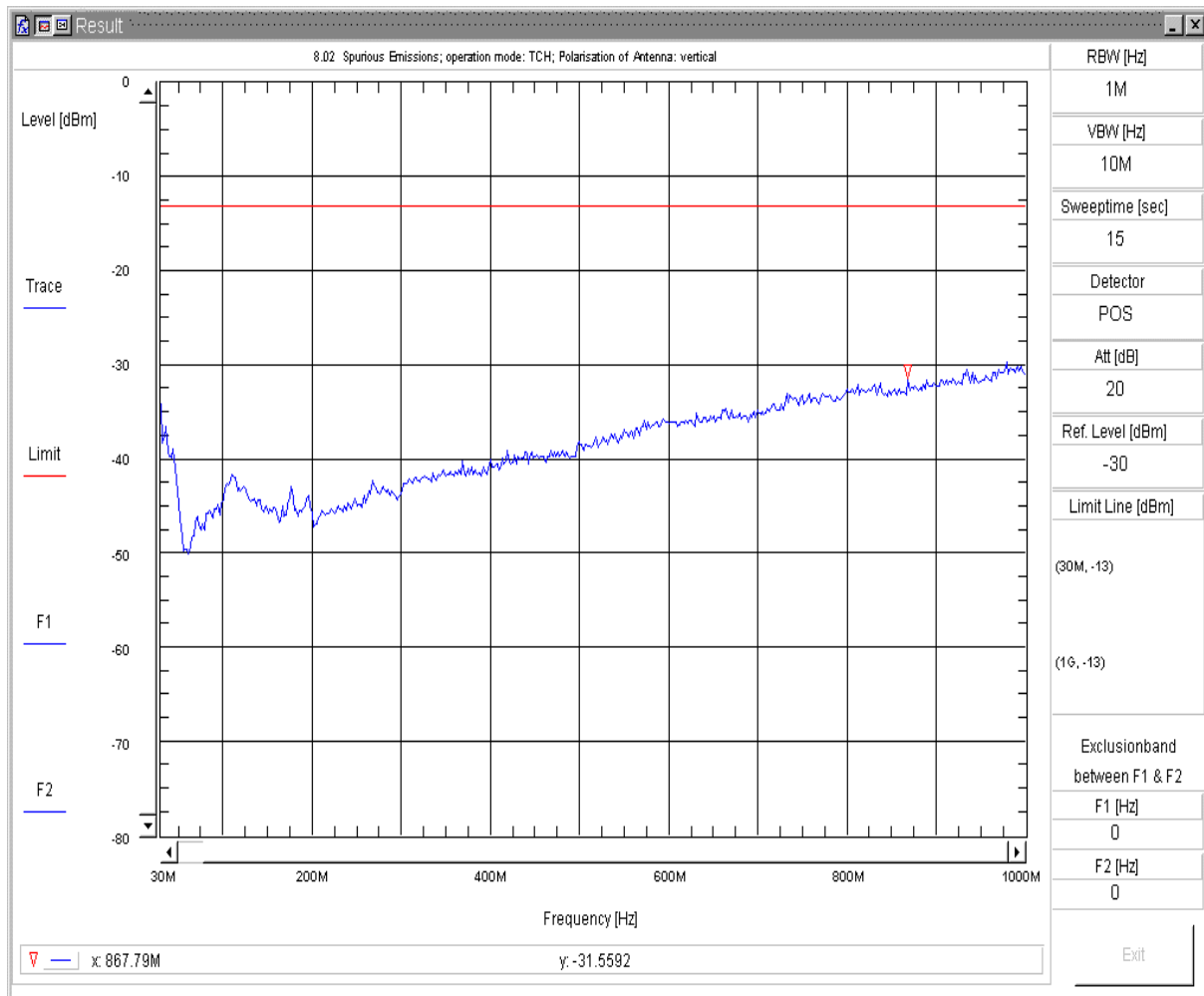

8.02 Radiated Spurious Emission

Transducer: c:\vee_user\spuri_V7\FCC_Part_24.238_(GSM_1900)\TD_TX_V
 Sweepnr: Sweep1
 Pol. of Antenna: vertikal
 EUT Position: EUT_vertical+horizontal
 EUT OP Mode: FCC_Part_24.238_(GSM_1900) TCH
 EUT Description: BGS2-W GSM Module
 EUT add. Info: DSB45+Adapter Board + Handset Votronic+RS232+USB-cable
 EUT Hardware: B2
 EUT Software:
 EUT Config:
 EUT S/N: 00440108048446800
 Battery: Power Supply (external); Maximum Voltage; 4.5 VDC
 Remark: channel 512
 Operator: Lor
 Testing Site: Fully Anechoic Room (FAR); CETECOM Essen

Fri 04/Feb/2011 09:28:39ppf

Spurious Emissions V7.2.5

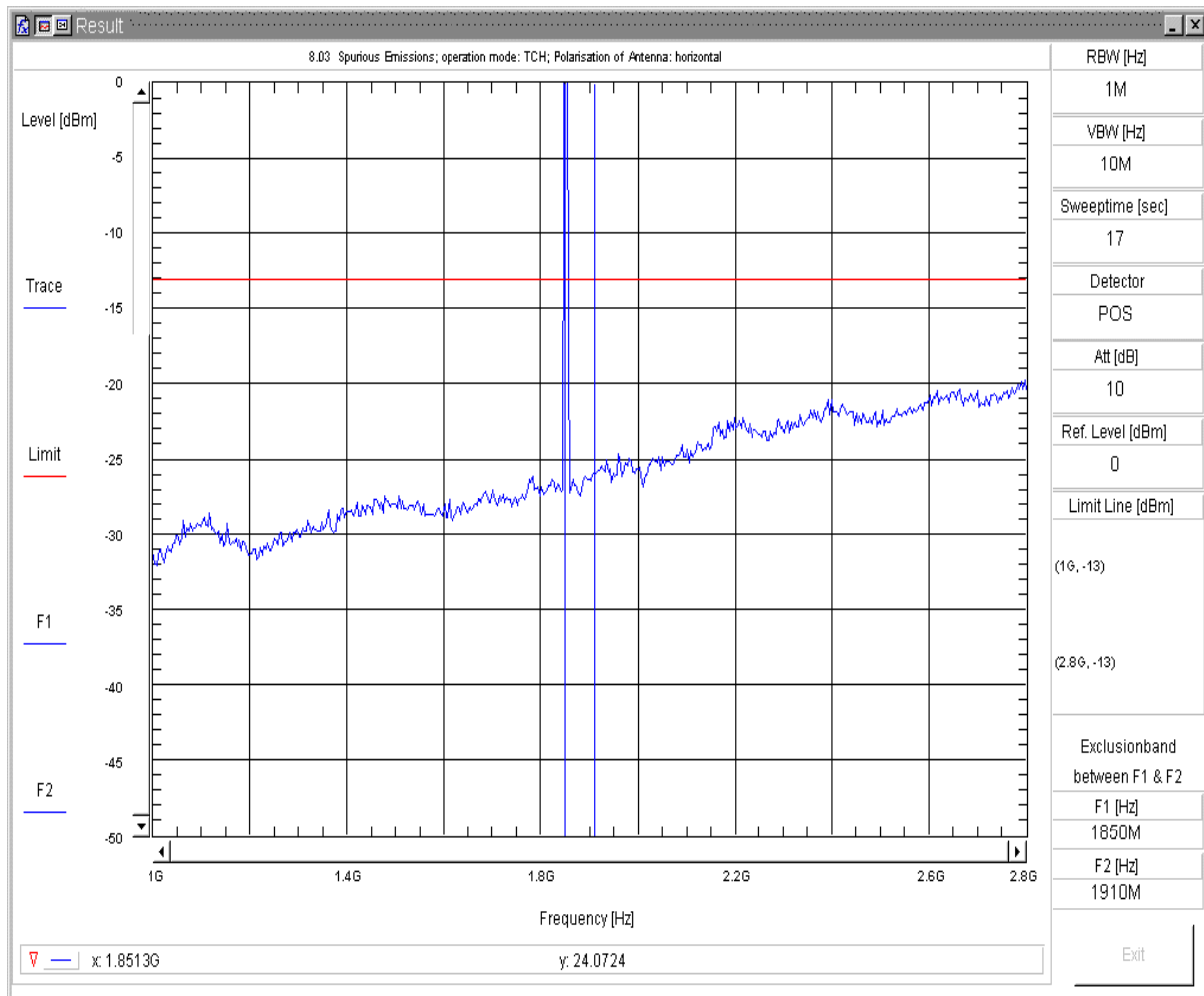

8.03 Radiated Spurious Emission

Transducer: c:\vee_user\spuri_V7\FCC_Part_24.238_(GSM_1900)\TD_TX_H
 Sweepnr: Sweep2
 Pol. of Antenna: horizontal
 EUT Position: EUT_vertical+horizontal
 EUT OP Mode: FCC_Part_24.238_(GSM_1900) TCH
 EUT Description: BGS2-W GSM Module
 EUT add. Info: DSB45+Adapter Board + Handset Votronic+RS232+USB-cable
 EUT Hardware: B2
 EUT Software:
 EUT Config:
 EUT S/N: 00440108048446800
 Battery: Power Supply (external); Maximum Voltage; 4.5 VDC
 Remark: channel 512
 Operator: Lor
 Testing Site: Fully Anechoic Room (FAR); CETECOM Essen

Fri 04/Feb/2011 09:32:46fp

Spurious Emissions V7.2.5

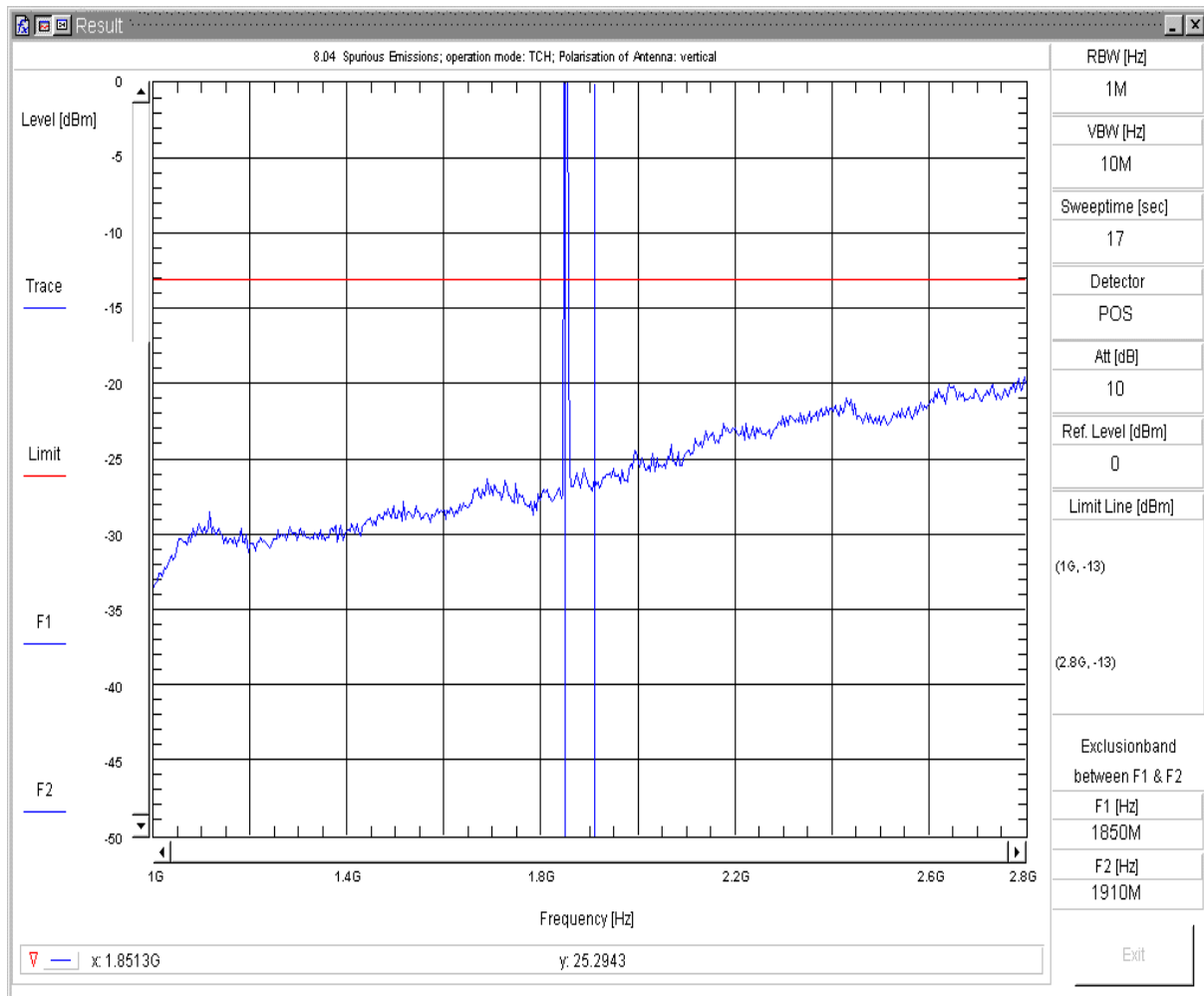

8.04 Radiated Spurious Emission

Transducer: c:\vee_user\spuri_V7\FCC_Part_24.238_(GSM_1900)\TD_TX_V
 Sweepnr: Sweep2
 Pol. of Antenna: vertikal
 EUT Position: EUT_vertical+horizontal
 EUT OP Mode: FCC_Part_24.238_(GSM_1900) TCH
 EUT Description: BGS2-W GSM Module
 EUT add. Info: DSB45+Adapter Board + Handset Votronic+RS232+USB-cable
 EUT Hardware: B2
 EUT Software:
 EUT Config:
 EUT S/N: 00440108048446800
 Battery: Power Supply (external); Maximum Voltage; 4.5 VDC
 Remark: channel 512
 Operator: Lor
 Testing Site: Fully Anechoic Room (FAR); CETECOM Essen

Fri 04/Feb/2011 09:40:43pf

Spurious Emissions V7.2.5

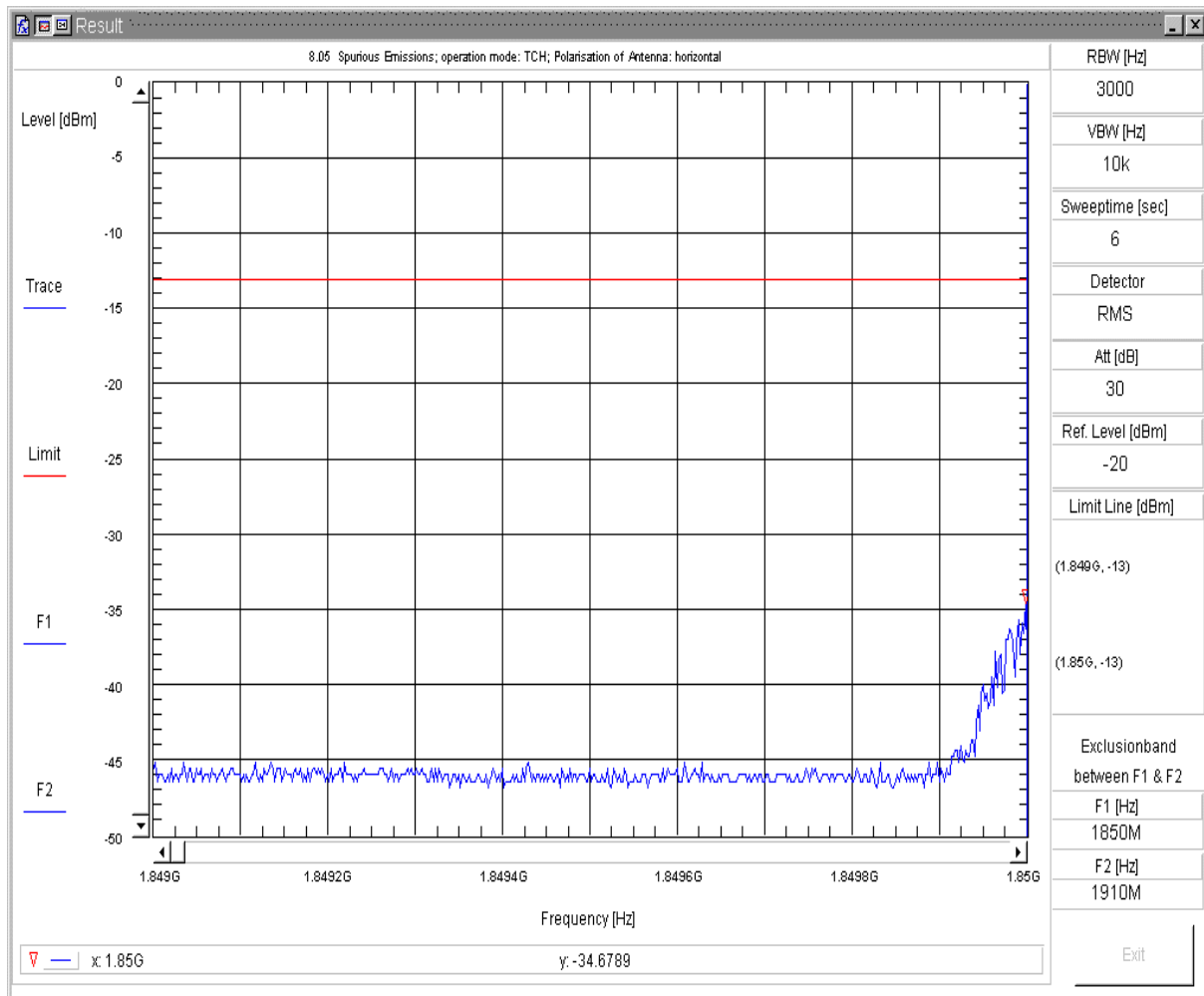

8.05 Radiated Spurious Emission

Transducer: c:\vee_user\spuri_V7\FCC_Part_24.238_(GSM_1900)\TD_TX_H
 Sweepnr: Sweep3
 Pol. of Antenna: horizontal
 EUT Position: EUT_vertical+horizontal
 EUT OP Mode: FCC_Part_24.238_(GSM_1900) TCH
 EUT Description: BGS2-W GSM Module
 EUT add. Info:
 EUT Hardware: B2
 EUT Software:
 EUT Config:
 EUT S/N: 00440108048446800
 Battery: Power Supply (external); Maximum Voltage; 4.5 VDC
 Remark: channel 512
 Operator: Lor
 Testing Site: Fully Anechoic Room (FAR); CETECOM Essen

Fri 04/Feb/2011 09:47:50fp

Spurious Emissions V7.2.5

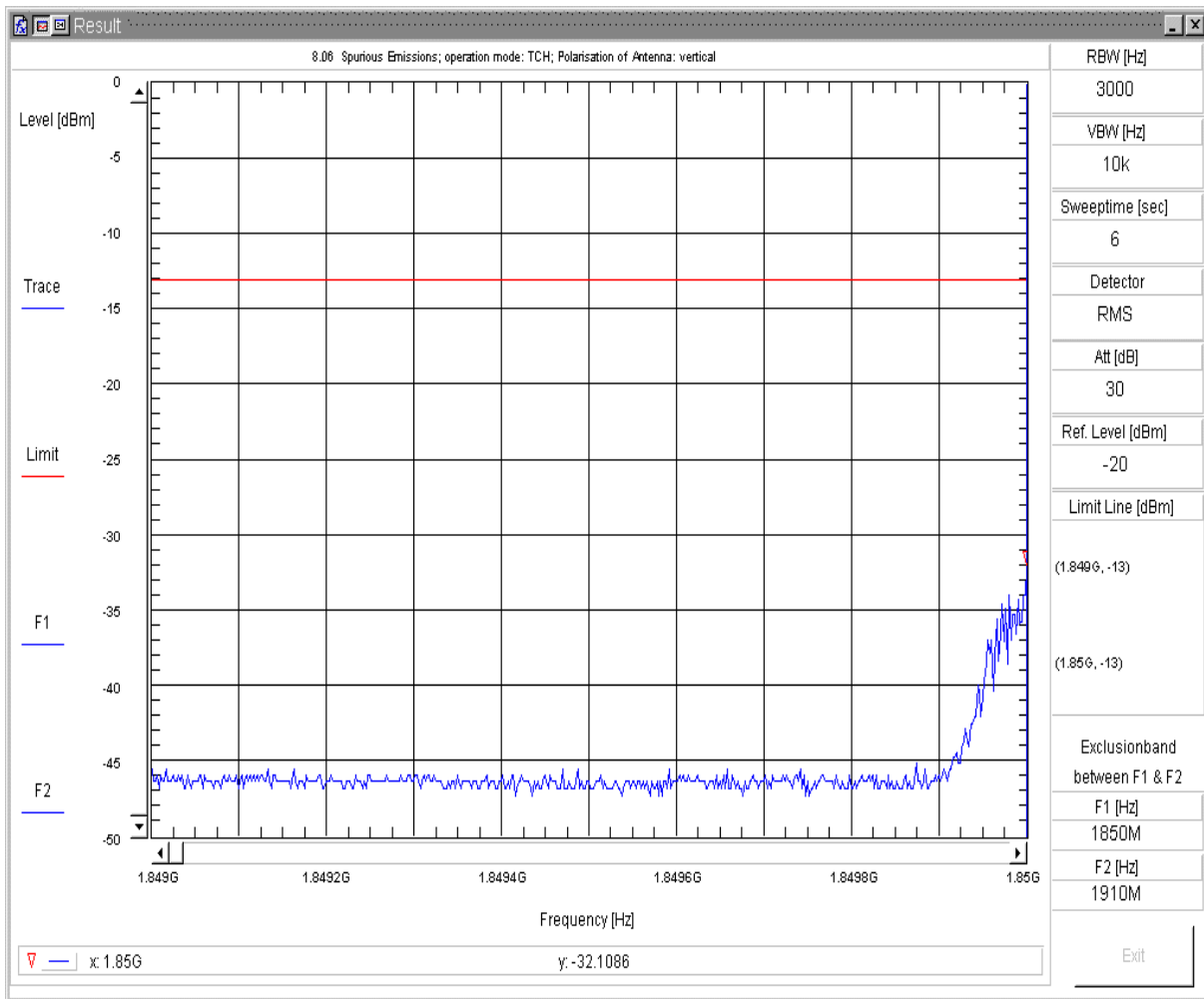

8.06 Radiated Spurious Emission

Transducer: c:\vee_user\spuri_V7\FCC_Part_24.238_(GSM_1900)\TD_TX_V
 Sweepnr: Sweep3
 Pol. of Antenna: vertikal
 EUT Position: EUT_vertical+horizontal
 EUT OP Mode: FCC_Part_24.238_(GSM_1900) TCH
 EUT Description: BGS2-W GSM Module
 EUT add. Info: DSB45+Adapter Board + Handset Votronic+RS232+USB-cable
 EUT Hardware: B2
 EUT Software:
 EUT Config:
 EUT S/N: 00440108048446800
 Battery: Power Supply (external); Maximum Voltage; 4.5 VDC
 Remark: channel 512
 Operator: Lor
 Testing Site: Fully Anechoic Room (FAR); CETECOM Essen

Fri 04/Feb/2011 09:51:58pf

Spurious Emissions V7.2.5

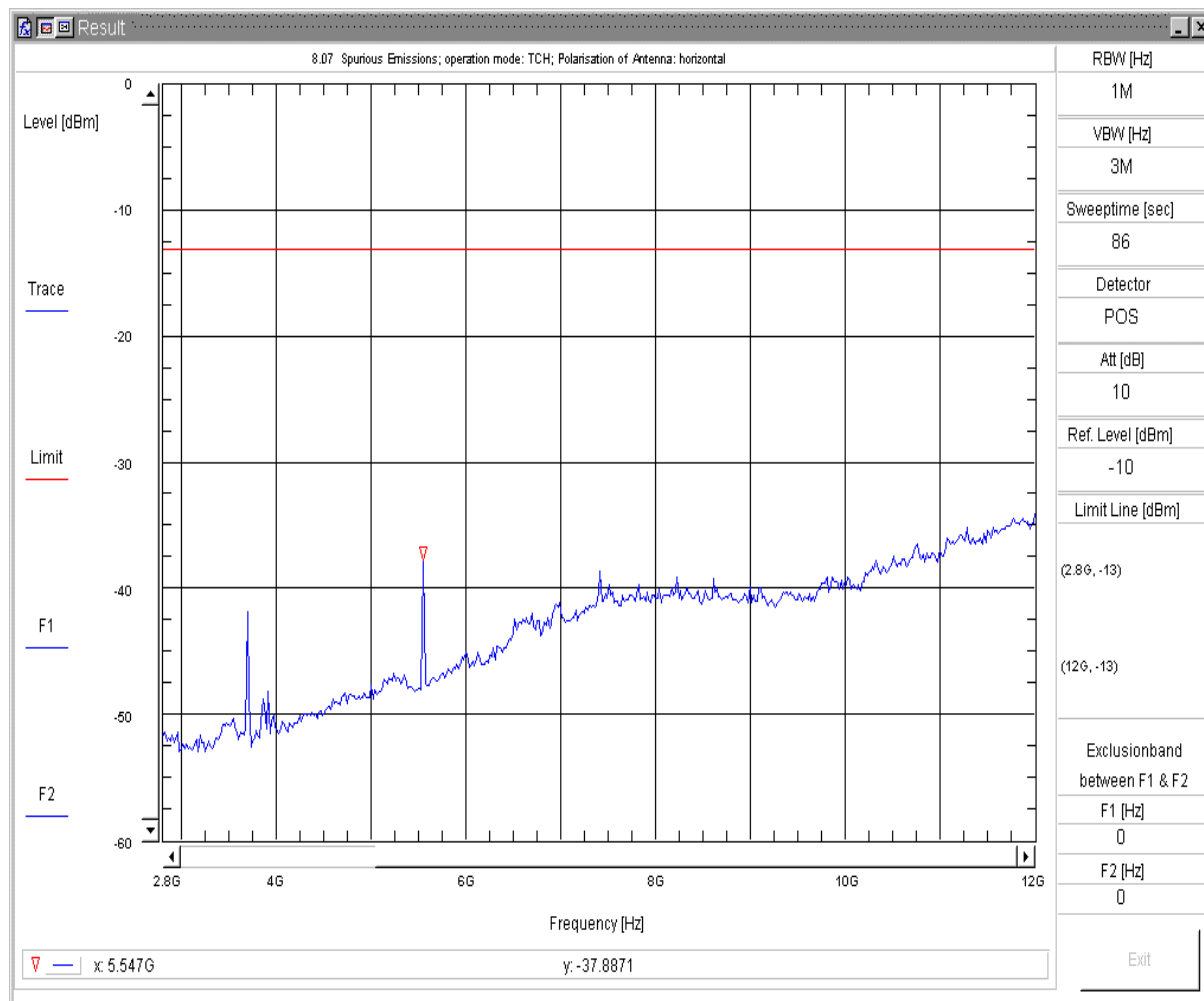

8.07 Radiated Spurious Emission

Transducer: c:\vee_user\spuri_V7\FCC_Part_24.238_(GSM_1900)\TD_TX_H
 Sweepnr: Sweep5
 Pol. of Antenna: horizontal
 EUT Position: EUT_vertical+horizontal
 EUT OP Mode: FCC_Part_24.238_(GSM_1900) TCH
 EUT Description: BGS2-W GSM Module
 EUT add. Info: DSB45+Adapter Board + Handset Votronic+RS232+USB-cable
 EUT Hardware: B2
 EUT Software:
 EUT Config:
 EUT S/N: 00440108048446800
 Battery: Power Supply (external); Maximum Voltage; 4.5 VDC
 Remark: channel 512
 Operator: Lor
 Testing Site: Fully Anechoic Room (FAR); CETECOM Essen

Fri 04/Feb/2011 09:56:24pp

Spurious Emissions V7.2.5

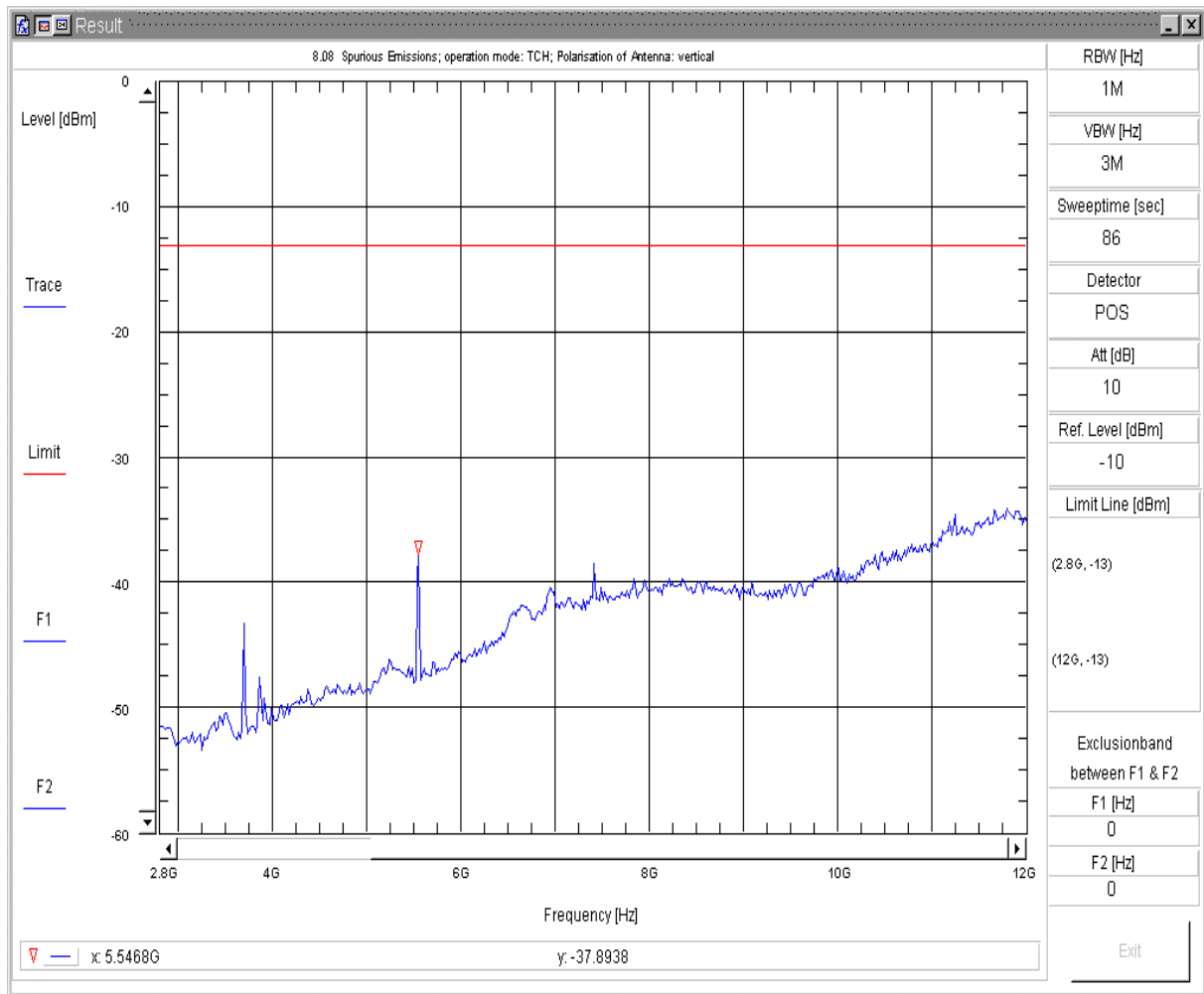

8.08 Radiated Spurious Emission

Transducer: c:\vee_user\spuri_V7\FCC_Part_24.238_(GSM_1900)\TD_TX_V
 Sweepnr: Sweep5
 Pol. of Antenna: vertikal
 EUT Position: EUT_vertical+horizontal
 EUT OP Mode: FCC_Part_24.238_(GSM_1900) TCH
 EUT Description: BGS2-W GSM Module
 EUT add. Info: DSB45+Adapter Board + Handset Votronic+RS232+USB-cable
 EUT Hardware: B2
 EUT Software:
 EUT Config:
 EUT S/N: 00440108048446800
 Battery: Power Supply (external); Maximum Voltage; 4.5 VDC
 Remark: channel 512
 Operator: Lor
 Testing Site: Fully Anechoic Room (FAR); CETECOM Essen

Fri 04/Feb/2011 10:19:15pp

Spurious Emissions V7.2.5

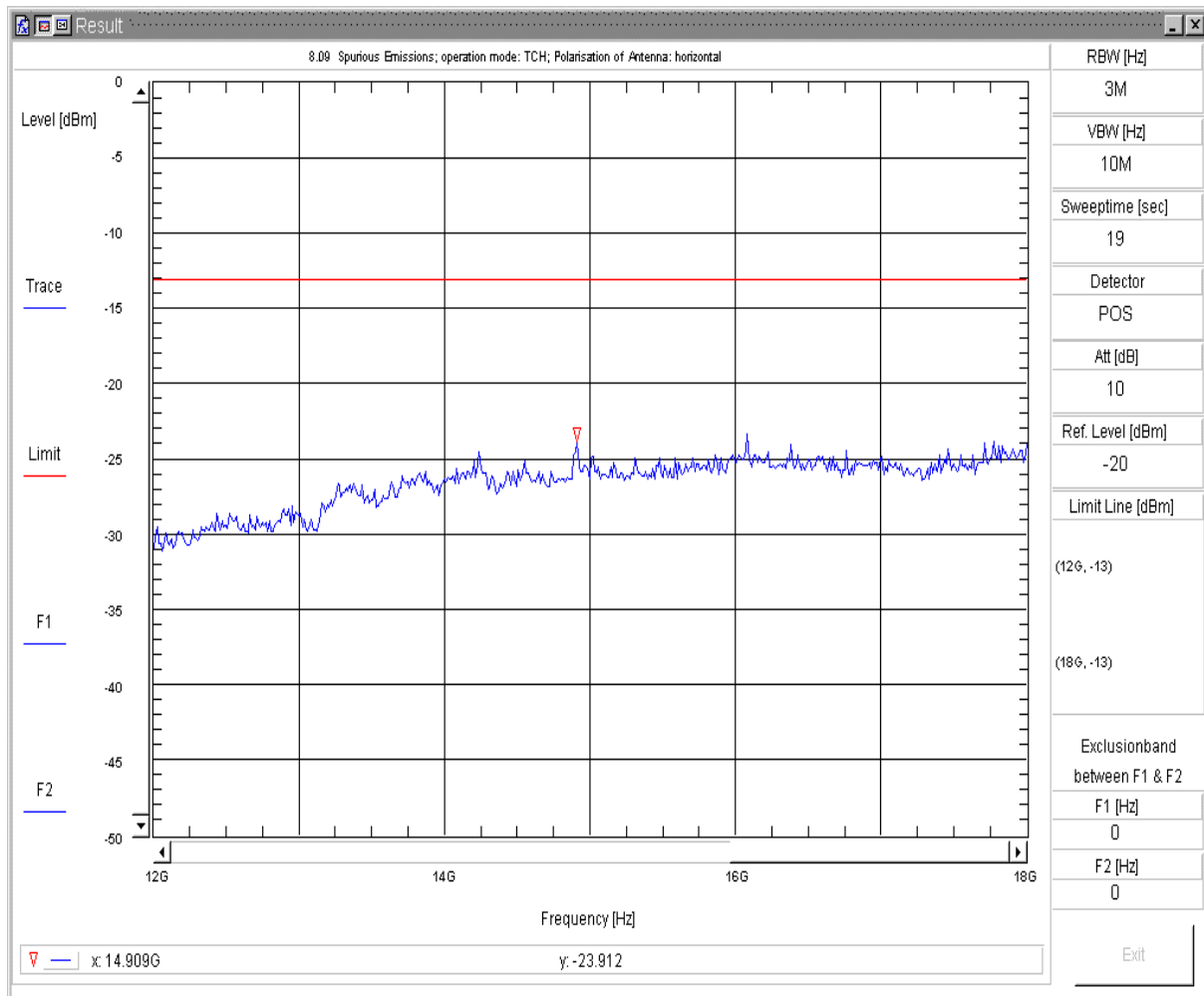

8.09 Radiated Spurious Emission

Transducer: c:\vee_user\spuri_V7\FCC_Part_24.238_(GSM_1900)\TD_TX_H
 Sweepnr: Sweep6
 Pol. of Antenna: horizontal
 EUT Position: EUT_vertical+horizontal
 EUT OP Mode: FCC_Part_24.238_(GSM_1900) TCH
 EUT Description: BGS2-W GSM Module
 EUT add. Info: DSB45+Adapter Board + Handset Votronic+RS232+USB-cable
 EUT Hardware: B2
 EUT Software:
 EUT Config:
 EUT S/N: 00440108048446800
 Battery: Power Supply (external); Maximum Voltage; 4.5 VDC
 Remark: channel 512
 Operator: Lor
 Testing Site: Fully Anechoic Room (FAR); CETECOM Essen

Fri 04/Feb/2011 10:42:15pp

Spurious Emissions V7.2.5

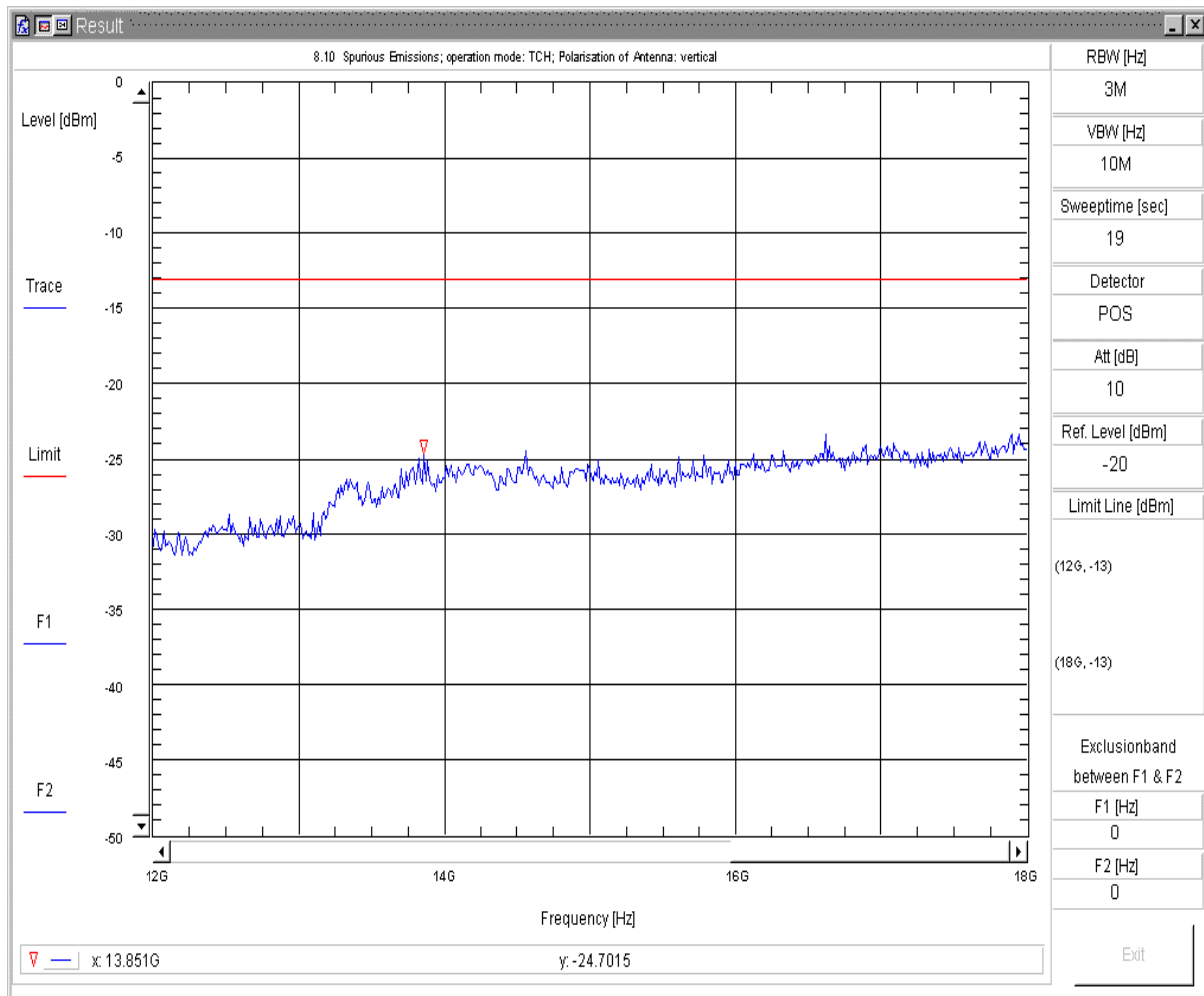

8.10 Radiated Spurious Emission

Transducer: c:\vee_user\spuri_V7\FCC_Part_24.238_(GSM_1900)\TD_TX_V
 Sweepnr: Sweep6
 Pol. of Antenna: vertikal
 EUT Position: EUT_vertical+horizontal
 EUT OP Mode: FCC_Part_24.238_(GSM_1900) TCH
 EUT Description: BGS2-W GSM Module
 EUT add. Info: DSB45+Adapter Board + Handset Votronic+RS232+USB-cable
 EUT Hardware: B2
 EUT Software:
 EUT Config:
 EUT S/N: 00440108048446800
 Battery: Power Supply (external); Maximum Voltage; 4.5 VDC
 Remark: channel 512
 Operator: Lor
 Testing Site: Fully Anechoic Room (FAR); CETECOM Essen

Fri 04/Feb/2011 10:49:55pp

Spurious Emissions V7.2.5

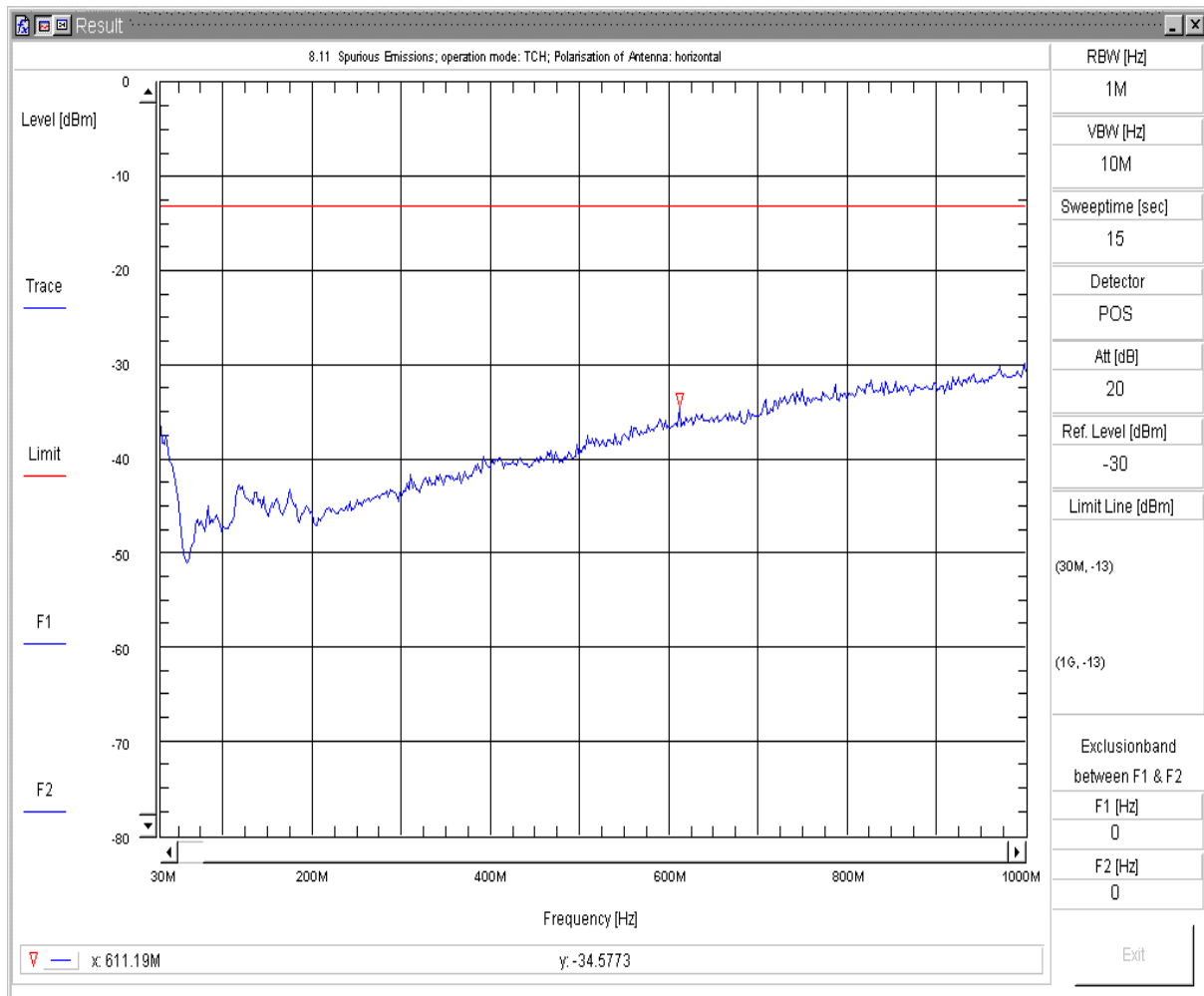

8.11 Radiated Spurious Emission

Transducer: c:\vee_user\spuri_V7\FCC_Part_24.238_(GSM_1900)\TD_TX_H
 Sweepnr: Sweep1
 Pol. of Antenna: horizontal
 EUT Position: EUT_vertical+horizontal
 EUT OP Mode: FCC_Part_24.238_(GSM_1900) TCH
 EUT Description: BGS2-W GSM Module
 EUT add. Info: DSB45+Adapter Board + Handset Votronic+RS232+USB-cable
 EUT Hardware: B2
 EUT Software:
 EUT Config:
 EUT S/N: 00440108048446800
 Battery: Power Supply (external); Maximum Voltage; 4.5 VDC
 Remark: channel 661
 Operator: Lor
 Testing Site: Fully Anechoic Room (FAR); CETECOM Essen

Fri 04/Feb/2011 10:57:32pfp

Spurious Emissions V7.2.5

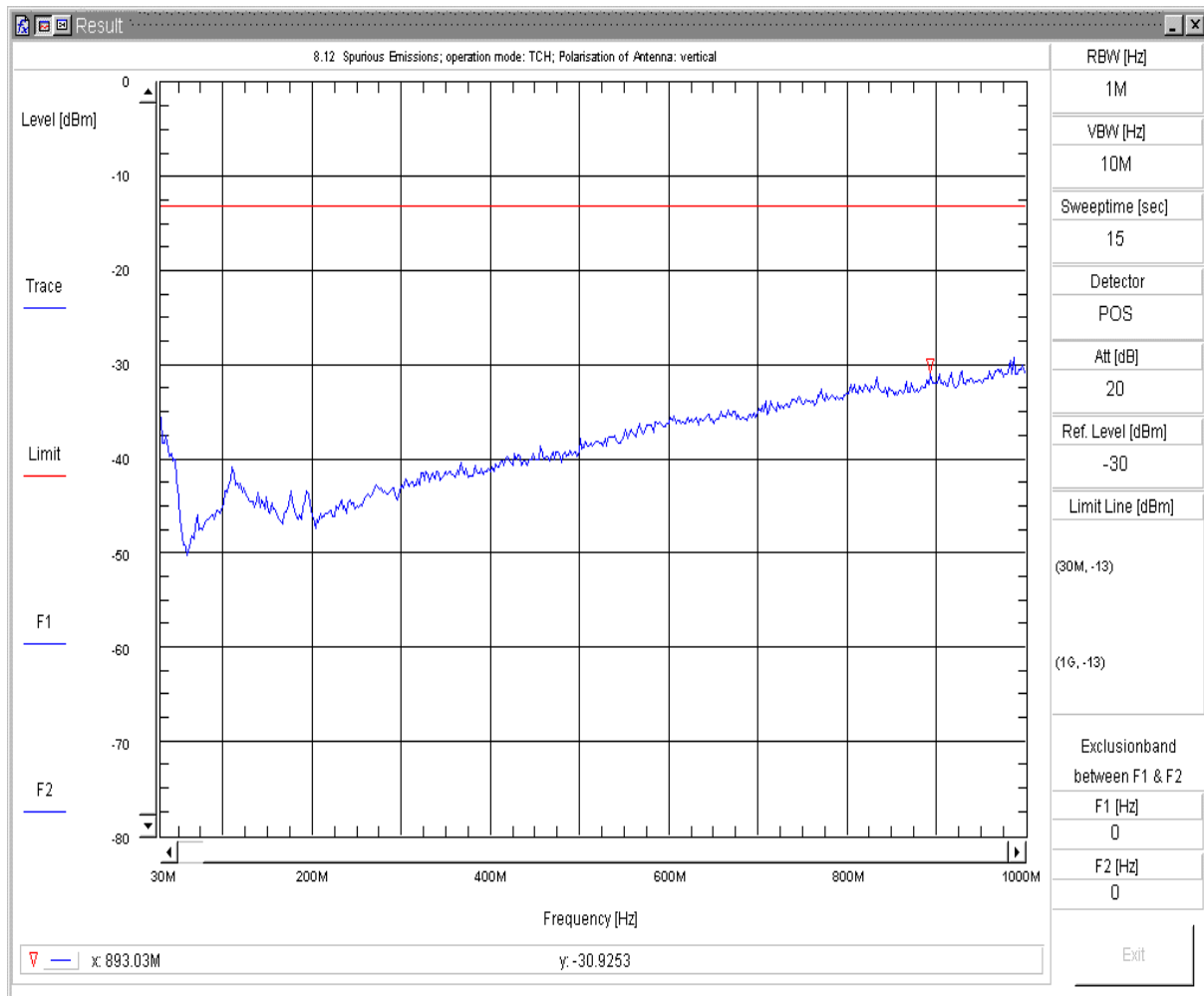

8.12 Radiated Spurious Emission

Transducer: c:\vee_user\spuri_V7\FCC_Part_24.238_(GSM_1900)\TD_TX_V
 Sweepnr: Sweep1
 Pol. of Antenna: vertikal
 EUT Position: EUT_vertical+horizontal
 EUT OP Mode: FCC_Part_24.238_(GSM_1900) TCH
 EUT Description: BGS2-W GSM Module
 EUT add. Info: DSB45+Adapter Board + Handset Votronic+RS232+USB-cable
 EUT Hardware: B2
 EUT Software:
 EUT Config:
 EUT S/N: 00440108048446800
 Battery: Power Supply (external); Maximum Voltage; 4.5 VDC
 Remark: channel 661
 Operator: Lor
 Testing Site: Fully Anechoic Room (FAR); CETECOM Essen

Fri 04/Feb/2011 11:02:39ppf

Spurious Emissions V7.2.5

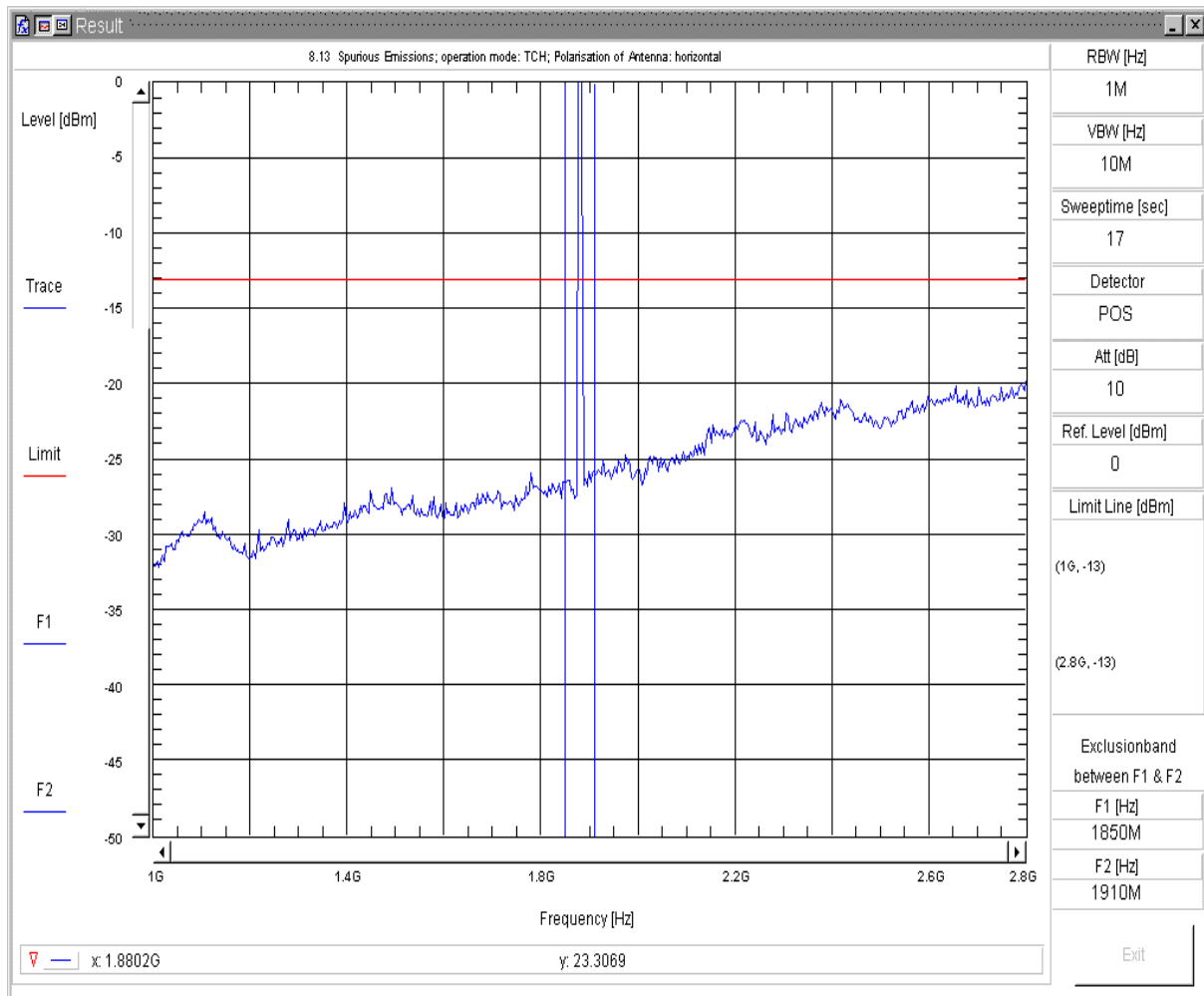

8.13 Radiated Spurious Emission

Transducer: c:\vee_user\spuri_V7\FCC_Part_24.238_(GSM_1900)\TD_TX_H
 Sweepnr: Sweep2
 Pol. of Antenna: horizontal
 EUT Position: EUT_vertical+horizontal
 EUT OP Mode: FCC_Part_24.238_(GSM_1900) TCH
 EUT Description: BGS2-W GSM Module
 EUT add. Info: DSB45+Adapter Board + Handset Votronic+RS232+USB-cable
 EUT Hardware: B2
 EUT Software:
 EUT Config:
 EUT S/N: 00440108048446800
 Battery: Power Supply (external); Maximum Voltage; 4.5 VDC
 Remark: channel 661
 Operator: Lor
 Testing Site: Fully Anechoic Room (FAR); CETECOM Essen

Fri 04/Feb/2011 11:16:01fp

Spurious Emissions V7.2.5

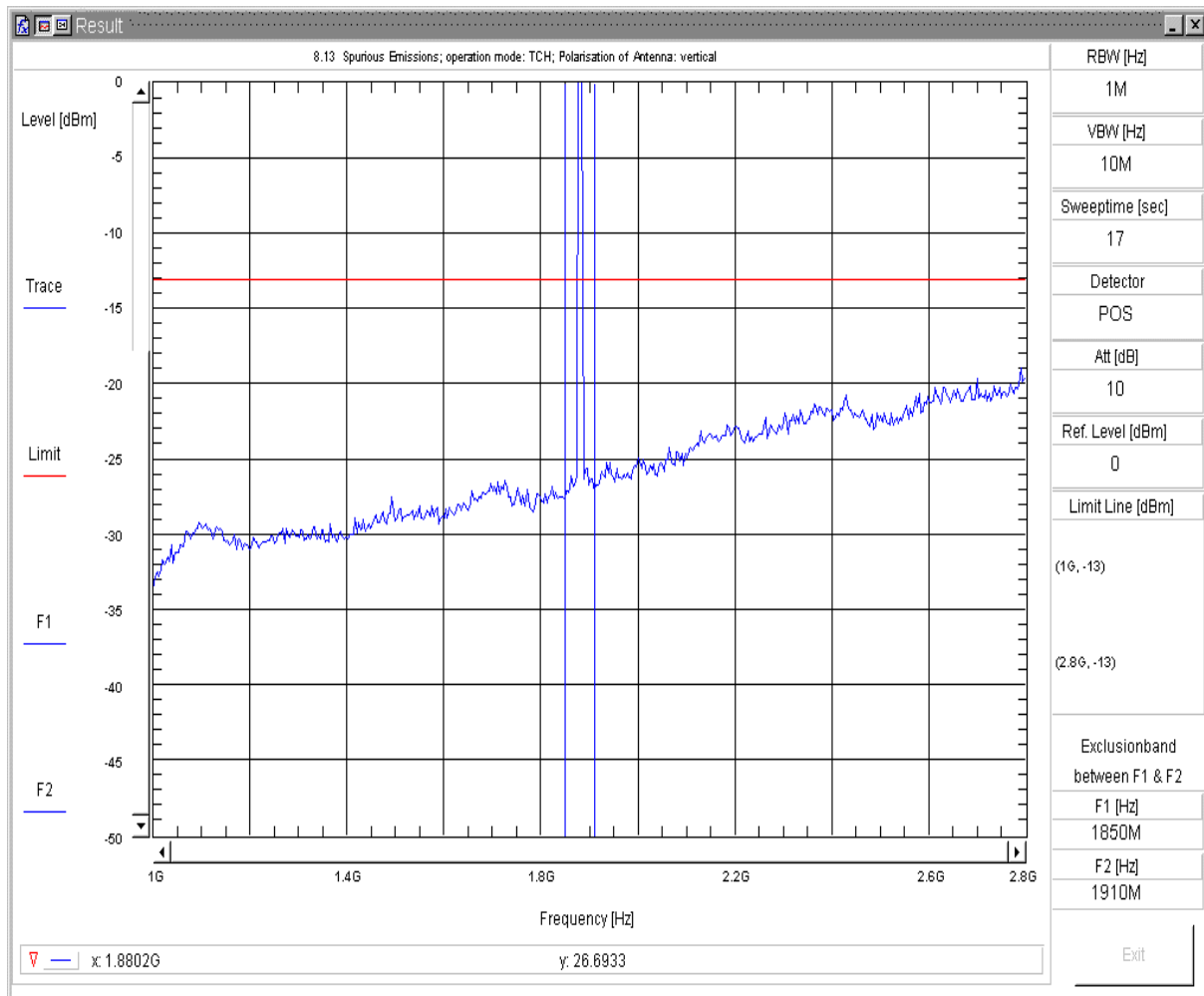

8.14 Radiated Spurious Emission

Transducer: c:\vee_user\spuri_V7\FCC_Part_24.238_(GSM_1900)\TD_TX_V
 Sweepnr: Sweep2
 Pol. of Antenna: vertikal
 EUT Position: EUT_vertical+horizontal
 EUT OP Mode: FCC_Part_24.238_(GSM_1900) TCH
 EUT Description: BGS2-W GSM Module
 EUT add. Info: DSB45+Adapter Board + Handset Votronic+RS232+USB-cable
 EUT Hardware: B2
 EUT Software:
 EUT Config:
 EUT S/N: 00440108048446800
 Battery: Power Supply (external); Maximum Voltage; 4.5 VDC
 Remark: channel 661
 Operator: Lor
 Testing Site: Fully Anechoic Room (FAR); CETECOM Essen

Fri 04/Feb/2011 11:07:40pf

Spurious Emissions V7.2.5

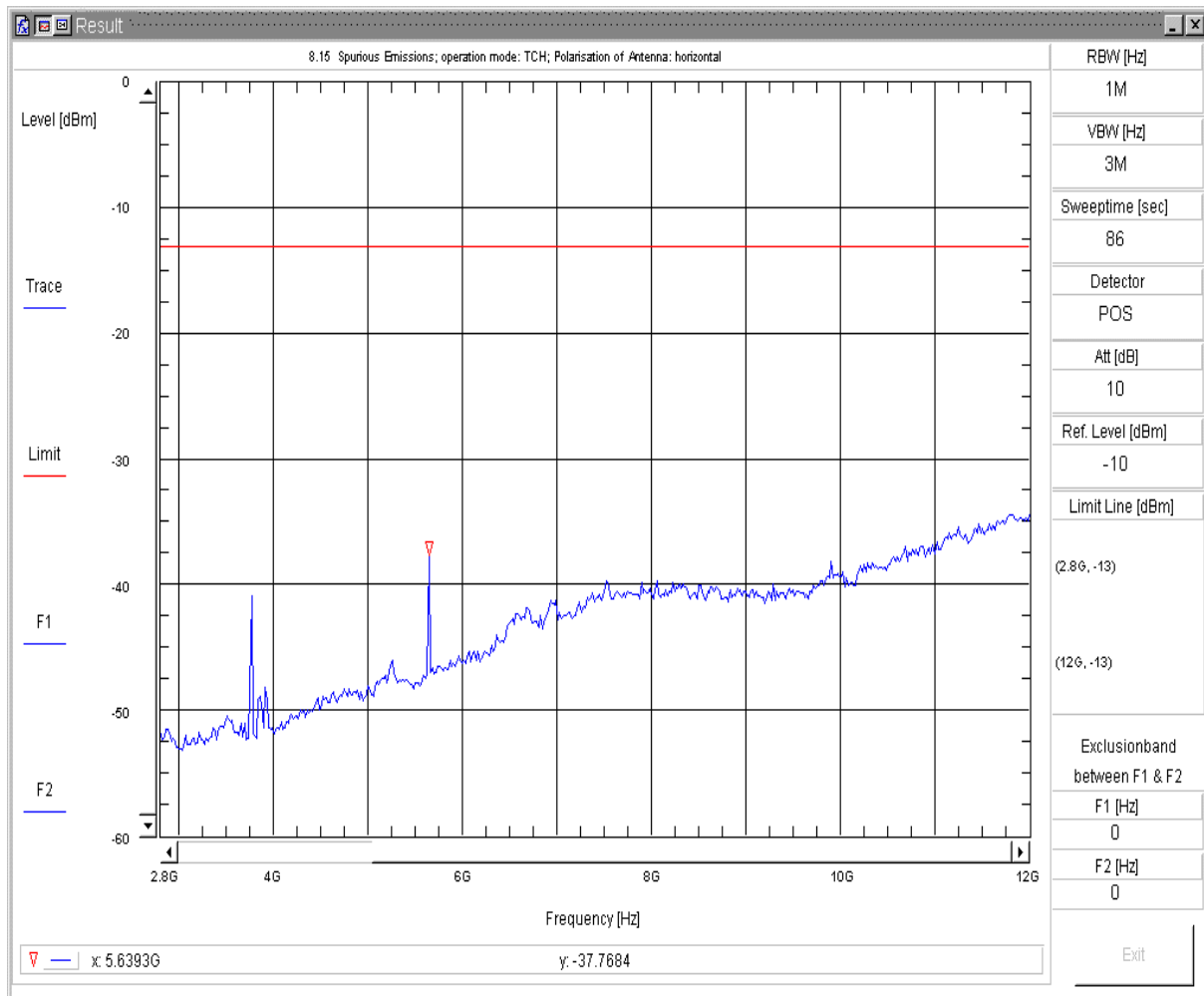

8.15 Radiated Spurious Emission

Transducer: c:\vee_user\spuri_V7\FCC_Part_24.238_(GSM_1900)\TD_TX_H
 Sweepnr: Sweep5
 Pol. of Antenna: horizontal
 EUT Position: EUT_vertical+horizontal
 EUT OP Mode: FCC_Part_24.238_(GSM_1900) TCH
 EUT Description: BGS2-W GSM Module
 EUT add. Info: DSB45+Adapter Board + Handset Votronic+RS232+USB-cable
 EUT Hardware: B2
 EUT Software:
 EUT Config:
 EUT S/N: 00440108048446800
 Battery: Power Supply (external); Maximum Voltage; 4.5 VDC
 Remark: channel 661
 Operator: Lor
 Testing Site: Fully Anechoic Room (FAR); CETECOM Essen

Fri 04/Feb/2011 11:23:20pp

Spurious Emissions V7.2.5

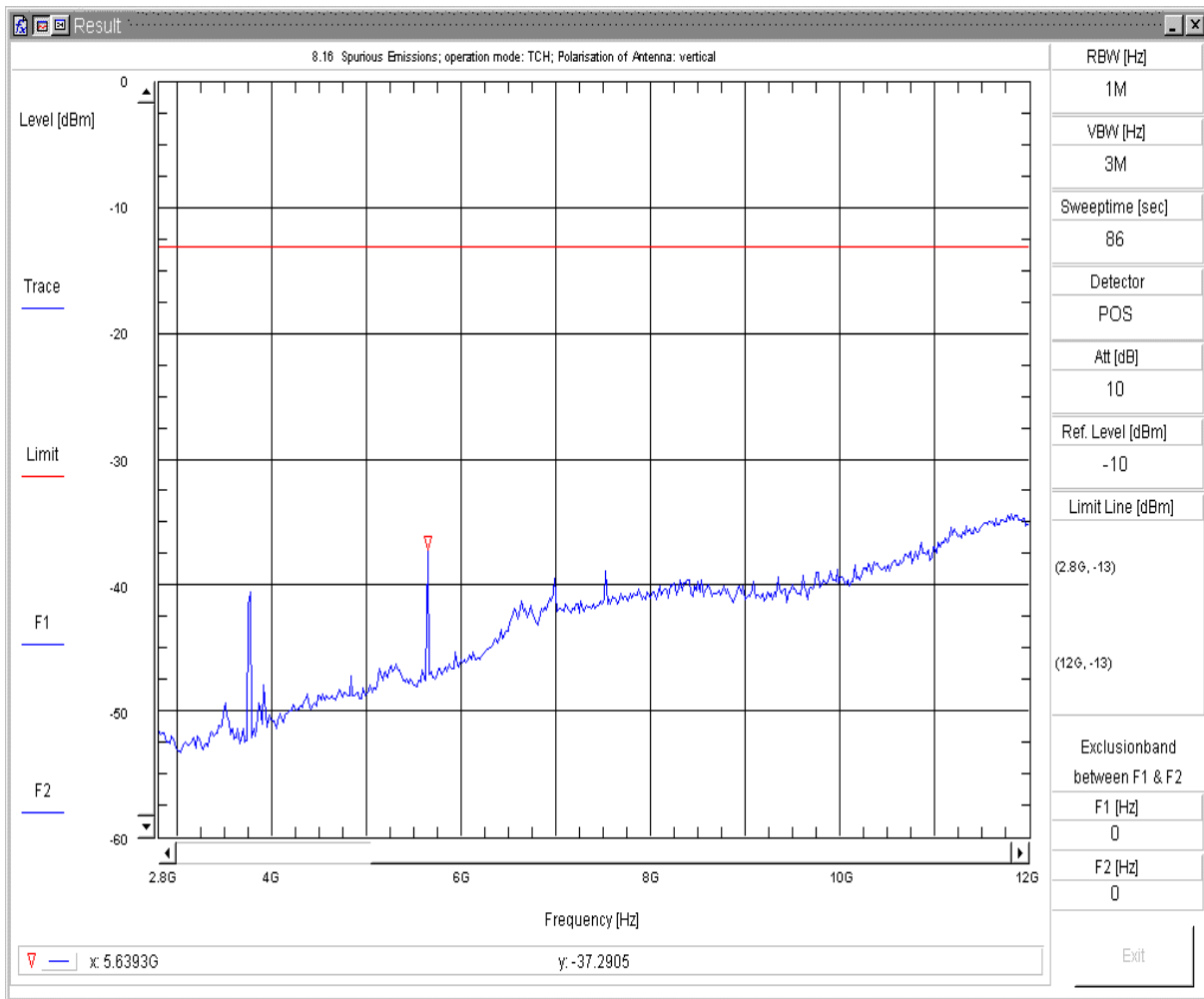

8.16 Radiated Spurious Emission

Transducer: c:\vee_user\spuri_V7\FCC_Part_24.238_(GSM_1900)\TD_TX_V
 Sweepnr: Sweep5
 Pol. of Antenna: vertikal
 EUT Position: EUT_vertical+horizontal
 EUT OP Mode: FCC_Part_24.238_(GSM_1900) TCH
 EUT Description: BGS2-W GSM Module
 EUT add. Info: DSB45+Adapter Board + Handset Votronic+RS232+USB-cable
 EUT Hardware: B2
 EUT Software:
 EUT Config:
 EUT S/N: 00440108048446800
 Battery: Power Supply (external); Maximum Voltage; 4.5 VDC
 Remark: channel 661
 Operator: Lor
 Testing Site: Fully Anechoic Room (FAR); CETECOM Essen

Fri 04/Feb/2011 11:46:14pp

Spurious Emissions V7.2.5

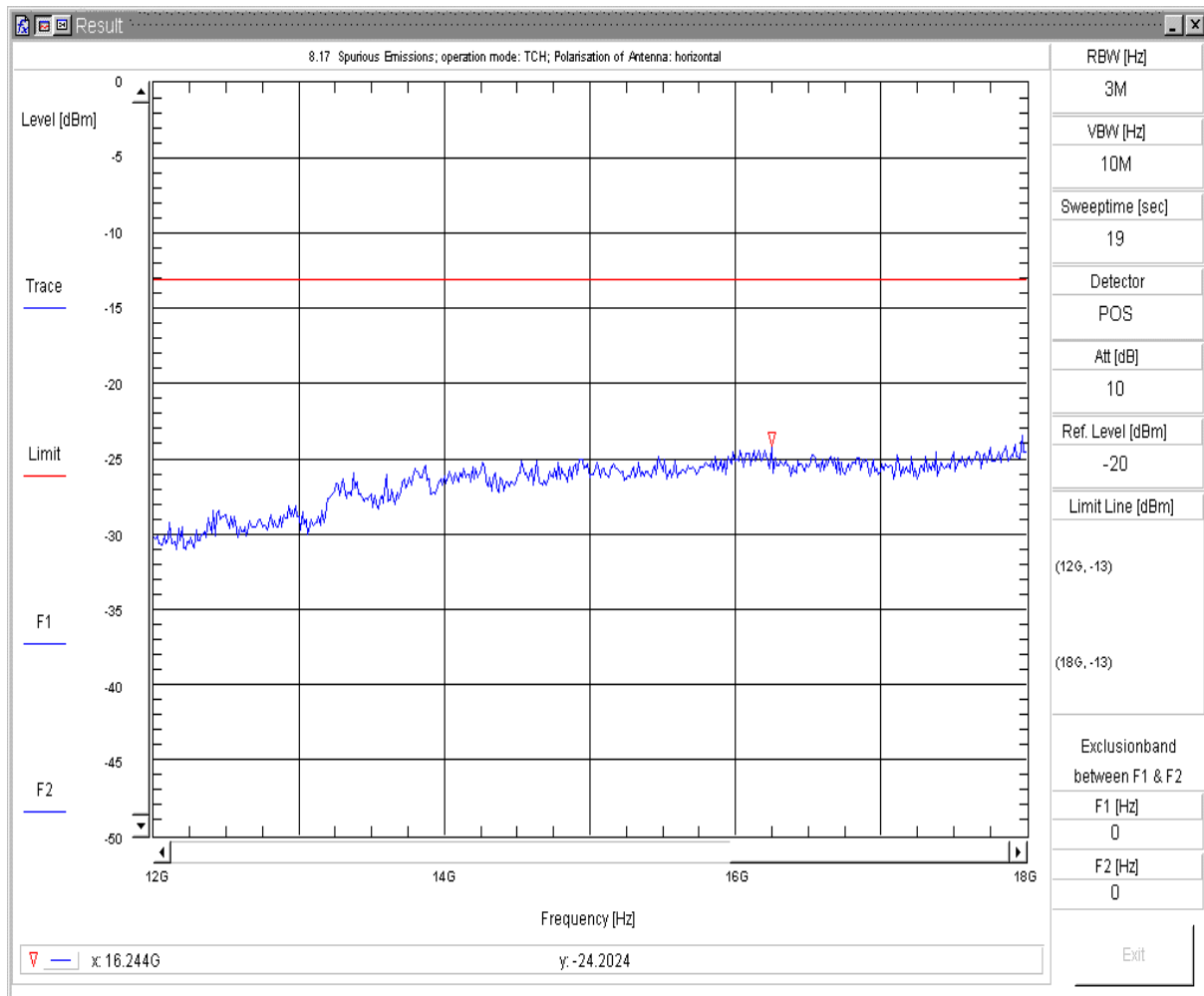

8.17 Radiated Spurious Emission

Transducer: c:\vee_user\spuri_V7\FCC_Part_24.238_(GSM_1900)\TD_TX_H
 Sweepnr: Sweep6
 Pol. of Antenna: horizontal
 EUT Position: EUT_vertical+horizontal
 EUT OP Mode: FCC_Part_24.238_(GSM_1900) TCH
 EUT Description: BGS2-W GSM Module
 EUT add. Info: DSB45+Adapter Board + Handset Votronic+RS232+USB-cable
 EUT Hardware: B2
 EUT Software:
 EUT Config:
 EUT S/N: 00440108048446800
 Battery: Power Supply (external); Maximum Voltage; 4.5 VDC
 Remark: channel 661
 Operator: Lor
 Testing Site: Fully Anechoic Room (FAR); CETECOM Essen

Fri 04/Feb/2011 12:09:04pp

Spurious Emissions V7.2.5

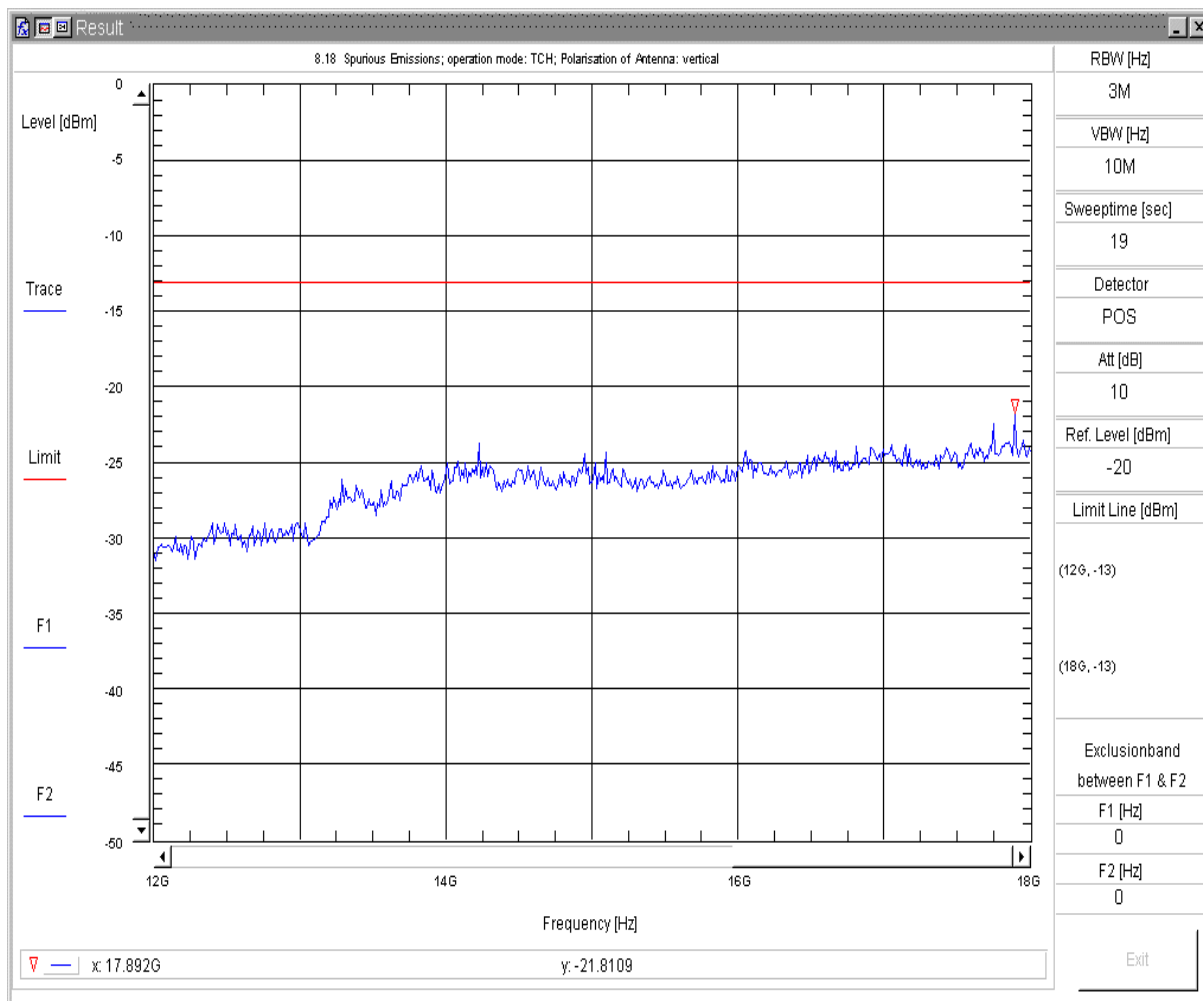

8.18 Radiated Spurious Emission

Transducer: c:\vee_user\spuri_V7\FCC_Part_24.238_(GSM_1900)\TD_TX_V
 Sweepnr: Sweep6
 Pol. of Antenna: vertikal
 EUT Position: EUT_vertical+horizontal
 EUT OP Mode: FCC_Part_24.238_(GSM_1900) TCH
 EUT Description: BGS2-W GSM Module
 EUT add. Info: DSB45+Adapter Board + Handset Votronic+RS232+USB-cable
 EUT Hardware: B2
 EUT Software:
 EUT Config:
 EUT S/N: 00440108048446800
 Battery: Power Supply (external); Maximum Voltage; 4.5 VDC
 Remark: channel 661
 Operator: Lor
 Testing Site: Fully Anechoic Room (FAR); CETECOM Essen

Fri 04/Feb/2011 12:16:21pp

Spurious Emissions V7.2.5

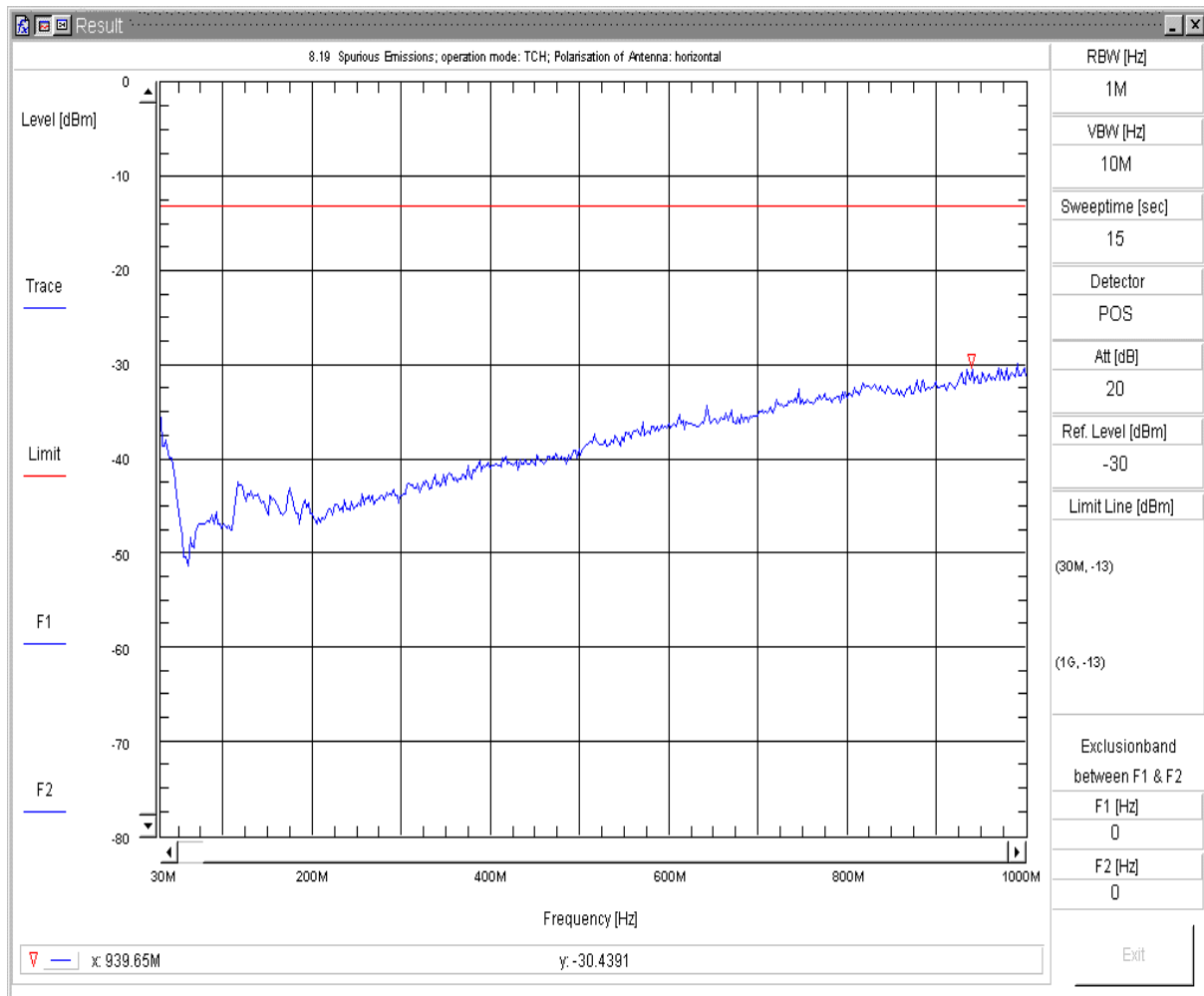

8.19 Radiated Spurious Emission

Transducer: c:\vee_user\spuri_V7\FCC_Part_24.238_(GSM_1900)\TD_TX_H
 Sweepnr: Sweep1
 Pol. of Antenna: horizontal
 EUT Position: EUT_vertical+horizontal
 EUT OP Mode: FCC_Part_24.238_(GSM_1900) TCH
 EUT Description: BGS2-W GSM Module
 EUT add. Info: DSB45+Adapter Board + Handset Votronic+RS232+USB-cable
 EUT Hardware: B2
 EUT Software:
 EUT Config:
 EUT S/N: 00440108048446800
 Battery: Power Supply (external); Maximum Voltage; 4.5 VDC
 Remark: channel 810
 Operator: Lor
 Testing Site: Fully Anechoic Room (FAR); CETECOM Essen

Fri 04/Feb/2011 12:23:55pfp

Spurious Emissions V7.2.5

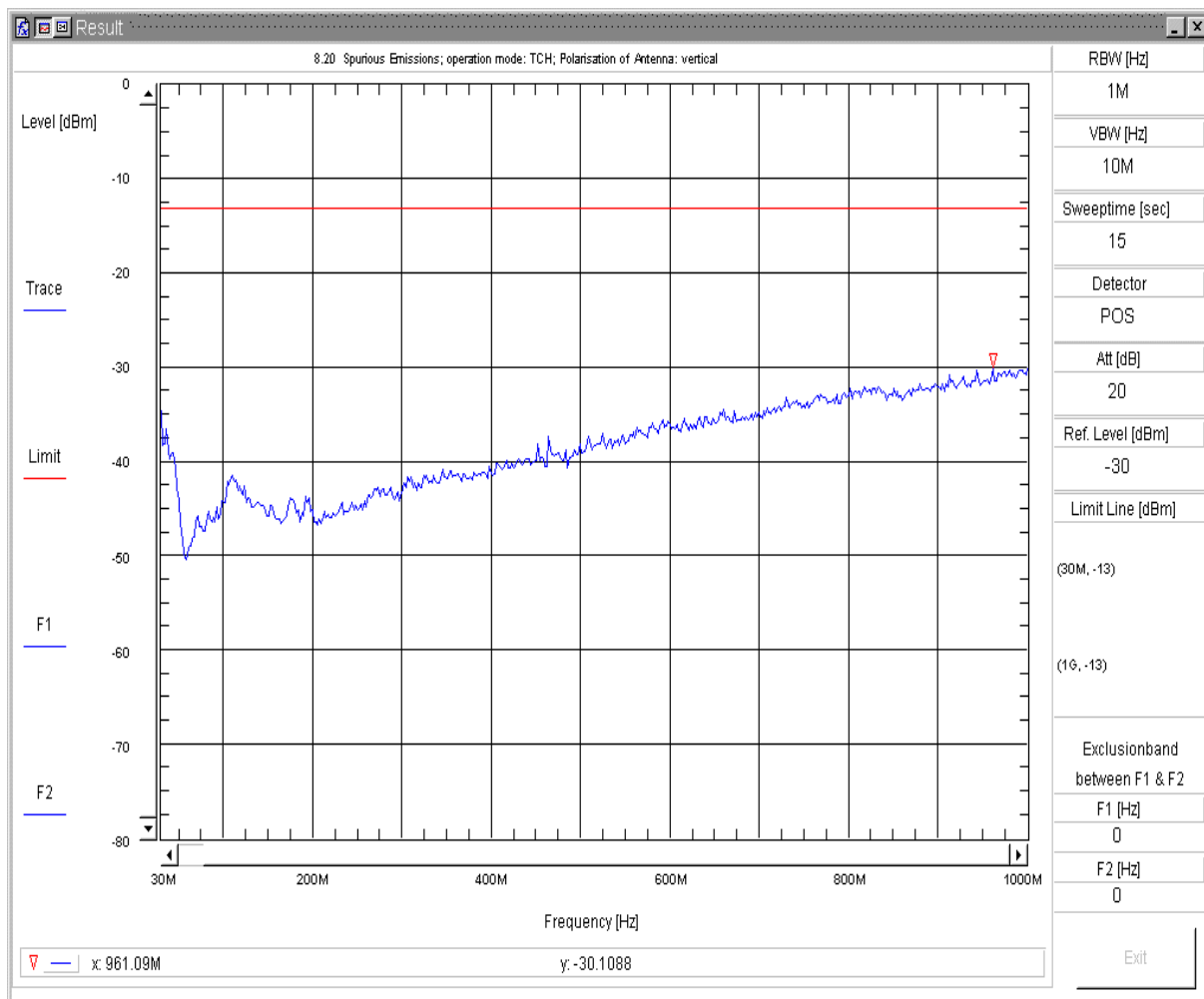

8.20 Radiated Spurious Emission

Transducer: c:\vee_user\spuri_V7\FCC_Part_24.238_(GSM_1900)\TD_TX_V
 Sweepnr: Sweep1
 Pol. of Antenna: vertikal
 EUT Position: EUT_vertical+horizontal
 EUT OP Mode: FCC_Part_24.238_(GSM_1900) TCH
 EUT Description: BGS2-W GSM Module
 EUT add. Info: DSB45+Adapter Board + Handset Votronic+RS232+USB-cable
 EUT Hardware: B2
 EUT Software:
 EUT Config:
 EUT S/N: 00440108048446800
 Battery: Power Supply (external); Maximum Voltage; 4.5 VDC
 Remark: channel 810
 Operator: Lor
 Testing Site: Fully Anechoic Room (FAR); CETECOM Essen

Fri 04/Feb/2011 12:30:31ppf

Spurious Emissions V7.2.5

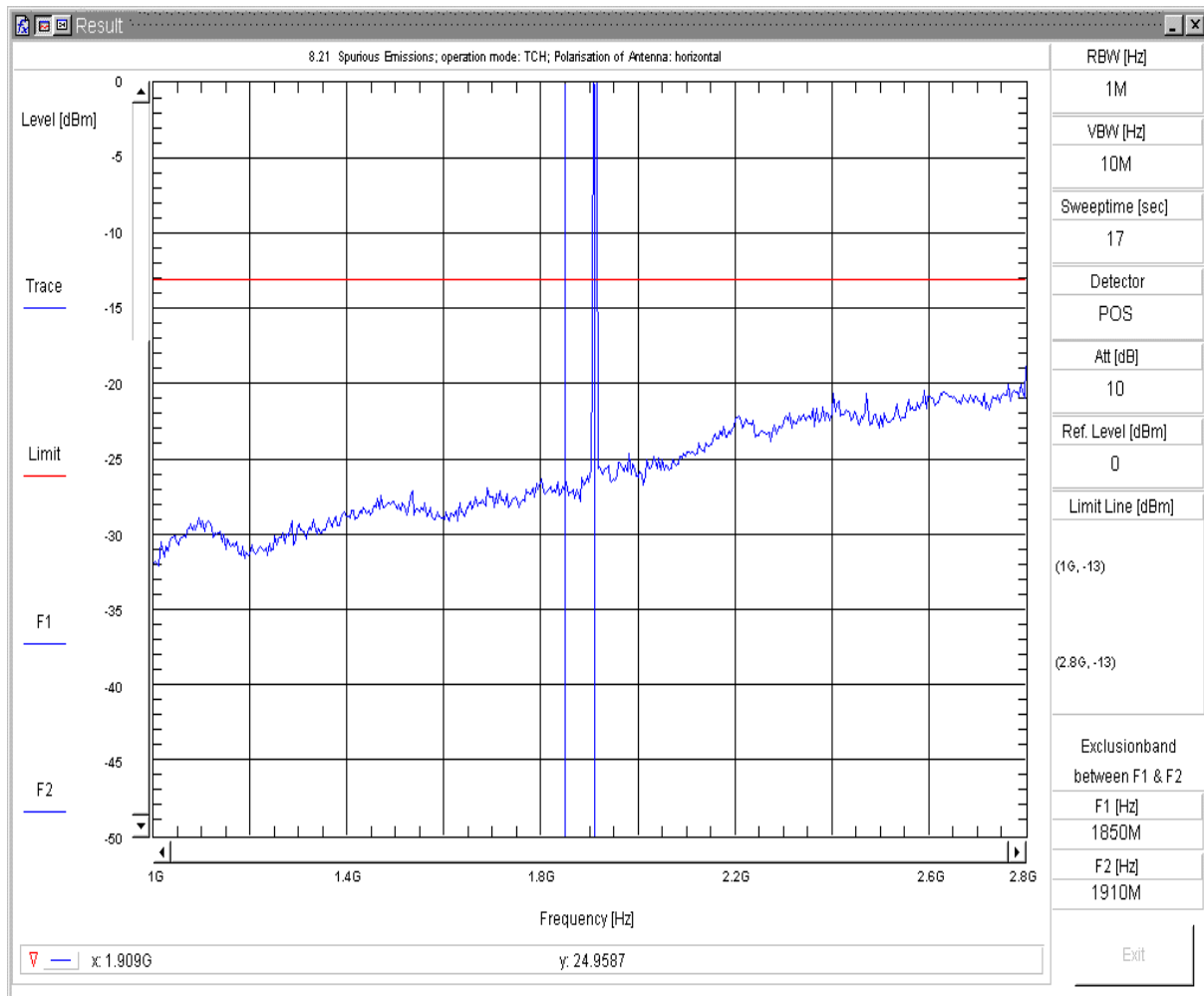

8.21 Radiated Spurious Emission

Transducer: c:\vee_user\spuri_V7\FCC_Part_24.238_(GSM_1900)\TD_TX_H
 Sweepnr: Sweep2
 Pol. of Antenna: horizontal
 EUT Position: EUT_vertical+horizontal
 EUT OP Mode: FCC_Part_24.238_(GSM_1900) TCH
 EUT Description: BGS2-W GSM Module
 EUT add. Info: DSB45+Adapter Board + Handset Votronic+RS232+USB-cable
 EUT Hardware: B2
 EUT Software:
 EUT Config:
 EUT S/N: 00440108048446800
 Battery: Power Supply (external); Maximum Voltage; 4.5 VDC
 Remark: channel 810
 Operator: Lor
 Testing Site: Fully Anechoic Room (FAR); CETECOM Essen

Fri 04/Feb/2011 12:34:45fp

Spurious Emissions V7.2.5

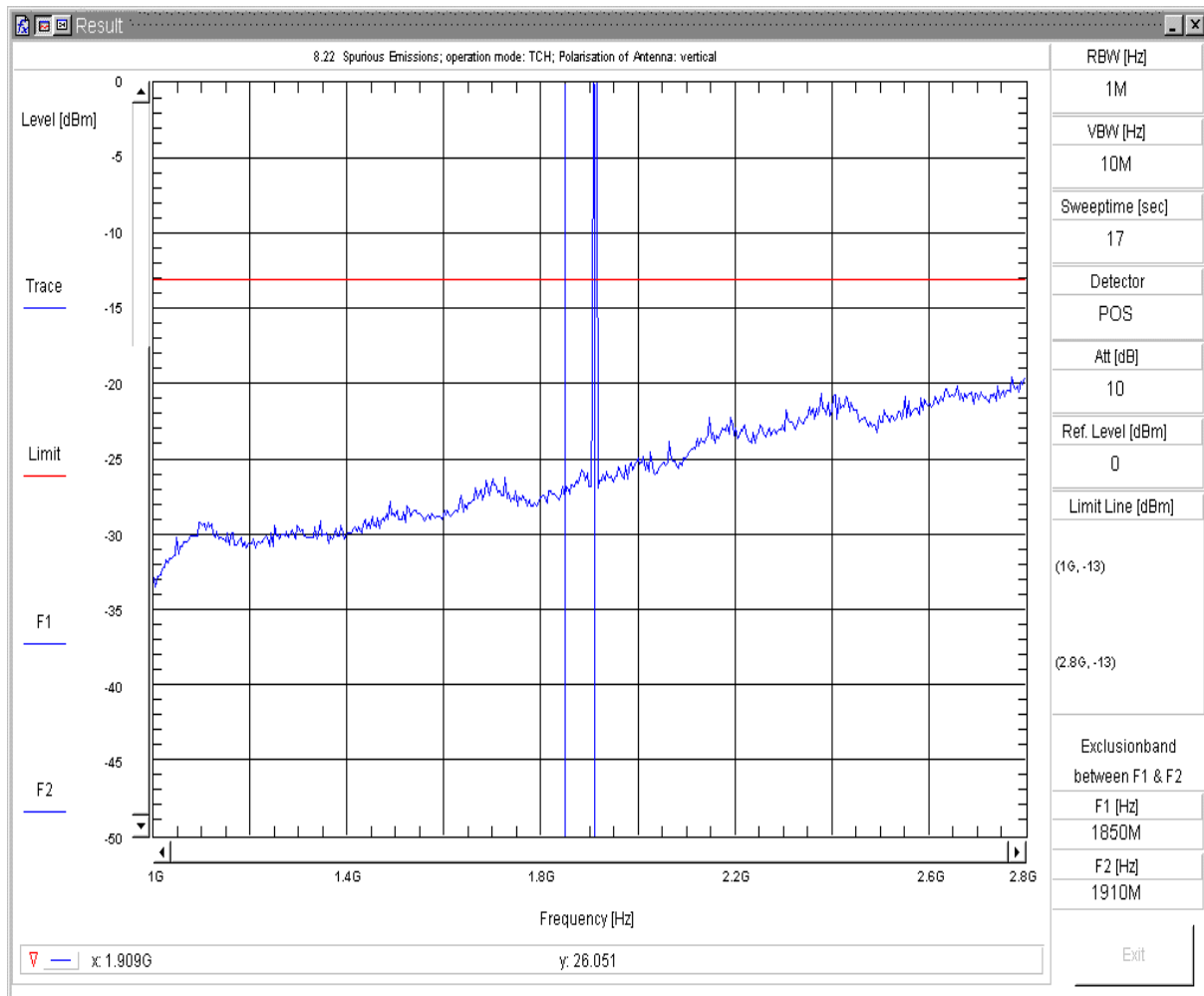

8.22 Radiated Spurious Emission

Transducer: c:\vee_user\spuri_V7\FCC_Part_24.238_(GSM_1900)\TD_TX_V
 Sweepnr: Sweep2
 Pol. of Antenna: vertikal
 EUT Position: EUT_vertical+horizontal
 EUT OP Mode: FCC_Part_24.238_(GSM_1900) TCH
 EUT Description: BGS2-W GSM Module
 EUT add. Info: DSB45+Adapter Board + Handset Votronic+RS232+USB-cable
 EUT Hardware: B2
 EUT Software:
 EUT Config:
 EUT S/N: 00440108048446800
 Battery: Power Supply (external); Maximum Voltage; 4.5 VDC
 Remark: channel 810
 Operator: Lor
 Testing Site: Fully Anechoic Room (FAR); CETECOM Essen

Fri 04/Feb/2011 12:41:40pf

Spurious Emissions V7.2.5

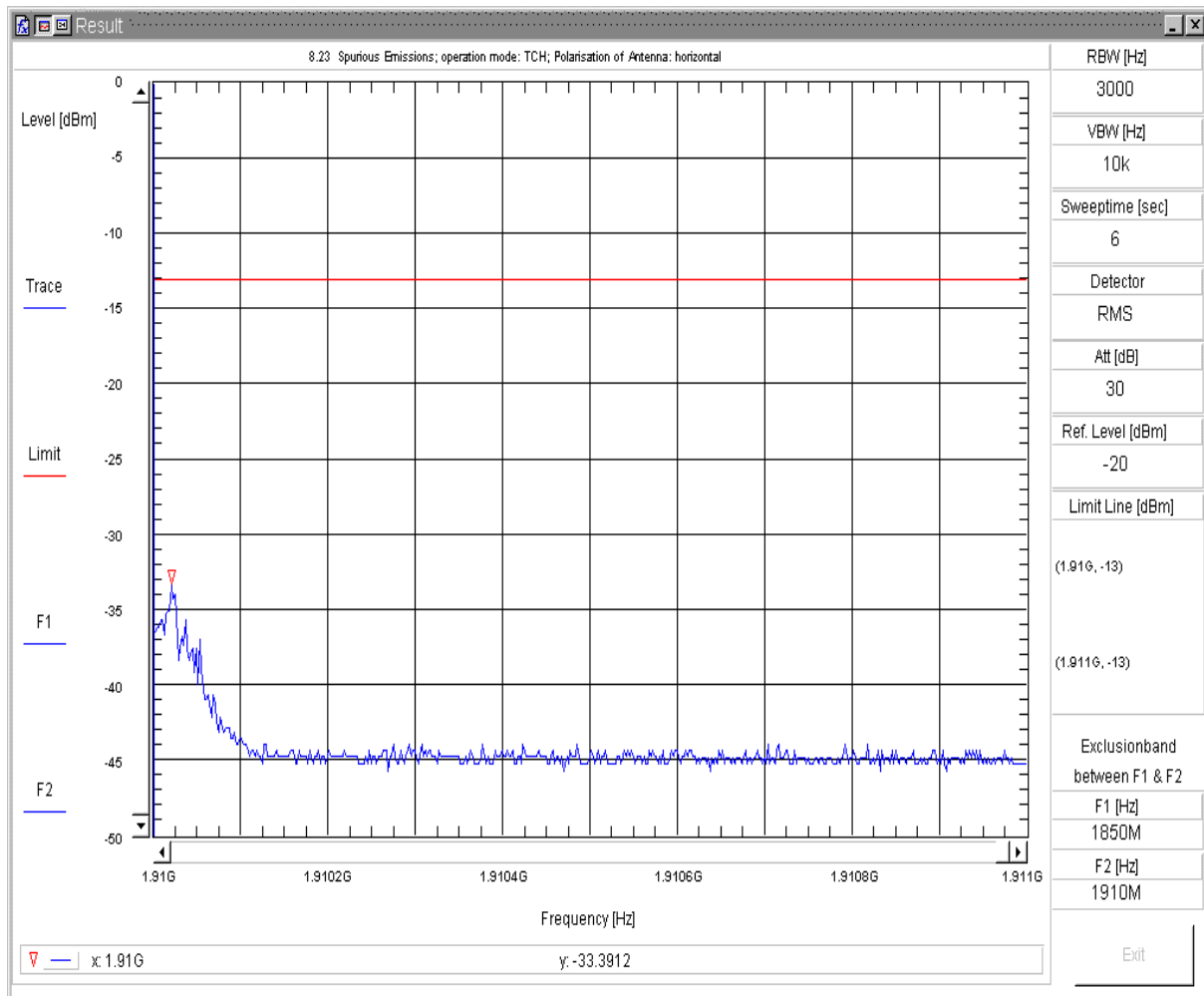

8.23 Radiated Spurious Emission

Transducer: c:\vee_user\spuri_V7\FCC_Part_24.238_(GSM_1900)\TD_TX_H
 Sweepnr: Sweep4
 Pol. of Antenna: horizontal
 EUT Position: EUT_vertical+horizontal
 EUT OP Mode: FCC_Part_24.238_(GSM_1900) TCH
 EUT Description: BGS2-W GSM Module
 EUT add. Info: DSB45+Adapter Board + Handset Votronic+RS232+USB-cable
 EUT Hardware: B2
 EUT Software:
 EUT Config:
 EUT S/N: 00440108048446800
 Battery: Power Supply (external); Maximum Voltage; 4.5 VDC
 Remark: channel 810
 Operator: Lor
 Testing Site: Fully Anechoic Room (FAR); CETECOM Essen

Fri 04/Feb/2011 12:48:36fp

Spurious Emissions V7.2.5

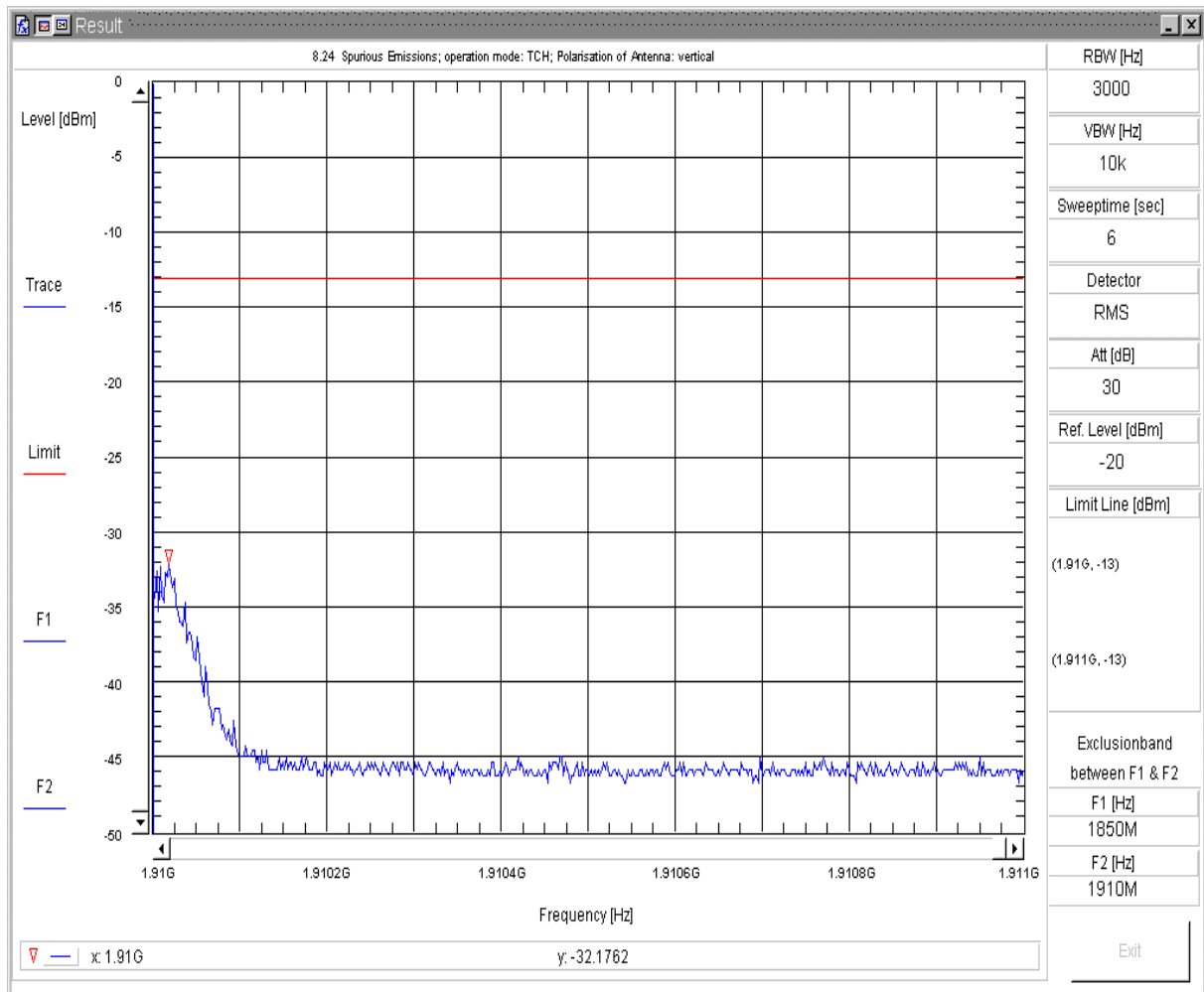

8.24 Radiated Spurious Emission

Transducer: c:\vee_user\spuri_V7\FCC_Part_24.238_(GSM_1900)\TD_TX_V
 Sweepnr: Sweep4
 Pol. of Antenna: vertikal
 EUT Position: EUT_vertical+horizontal
 EUT OP Mode: FCC_Part_24.238_(GSM_1900) TCH
 EUT Description: BGS2-W GSM Module
 EUT add. Info: DSB45+Adapter Board + Handset Votronic+RS232+USB-cable
 EUT Hardware: B2
 EUT Software:
 EUT Config:
 EUT S/N: 00440108048446800
 Battery: Power Supply (external); Maximum Voltage; 4.5 VDC
 Remark: channel 810
 Operator: Lor
 Testing Site: Fully Anechoic Room (FAR); CETECOM Essen

Fri 04/Feb/2011 12:52:52pf

Spurious Emissions V7.2.5

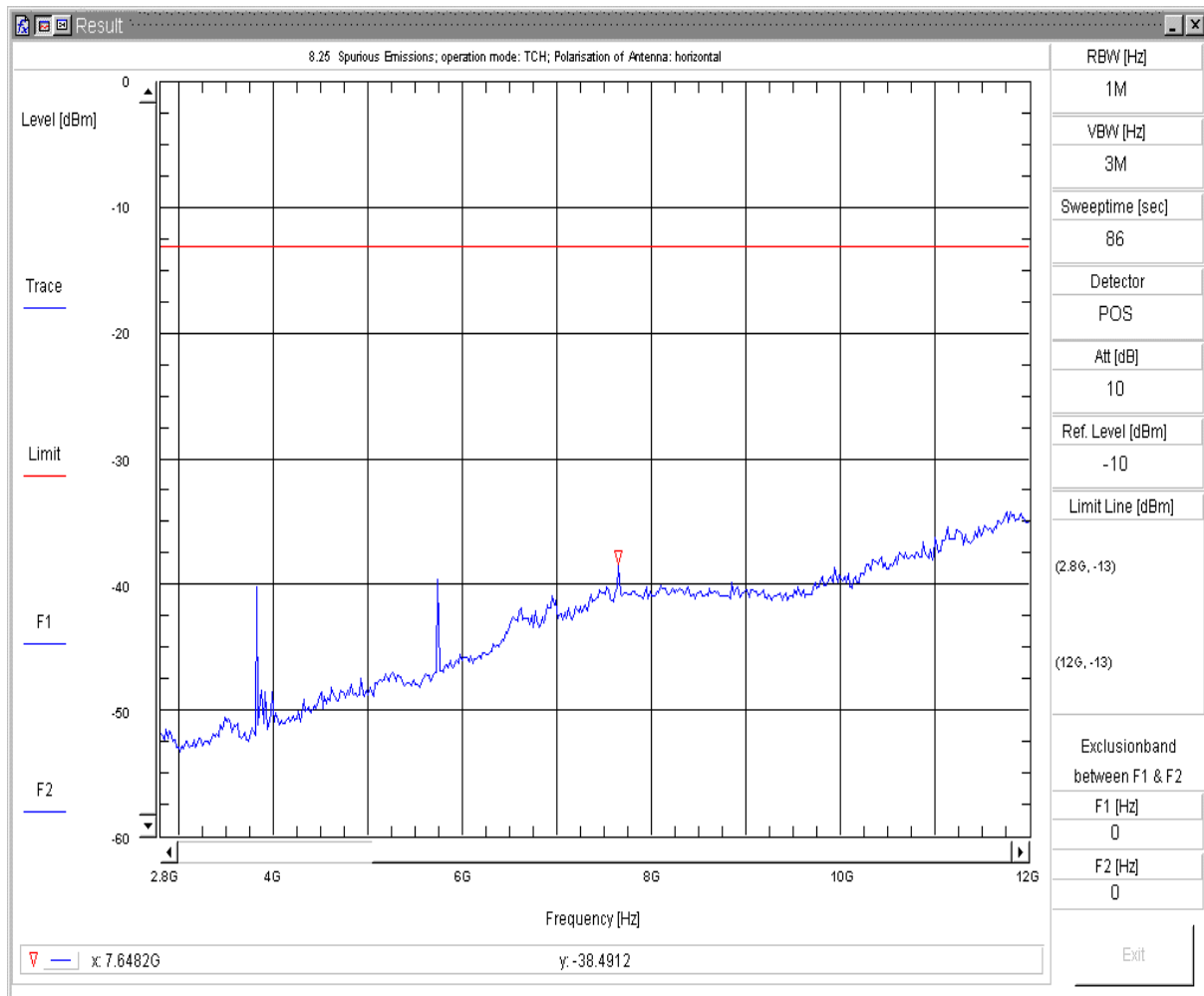

8.25 Radiated Spurious Emission

Transducer: c:\vee_user\spuri_V7\FCC_Part_24.238_(GSM_1900)\TD_TX_H
 Sweepnr: Sweep5
 Pol. of Antenna: horizontal
 EUT Position: EUT_vertical+horizontal
 EUT OP Mode: FCC_Part_24.238_(GSM_1900) TCH
 EUT Description: BGS2-W GSM Module
 EUT add. Info:
 EUT Hardware: B2
 EUT Software:
 EUT Config:
 EUT S/N: 00440108048446800
 Battery: Power Supply (external); Maximum Voltage; 4.5 VDC
 Remark: -ARFCN 810
 Operator: Lor
 Testing Site: Fully Anechoic Room (FAR); CETECOM Essen

Fri 04/Feb/2011 12:57:09fp

Spurious Emissions V7.2.5

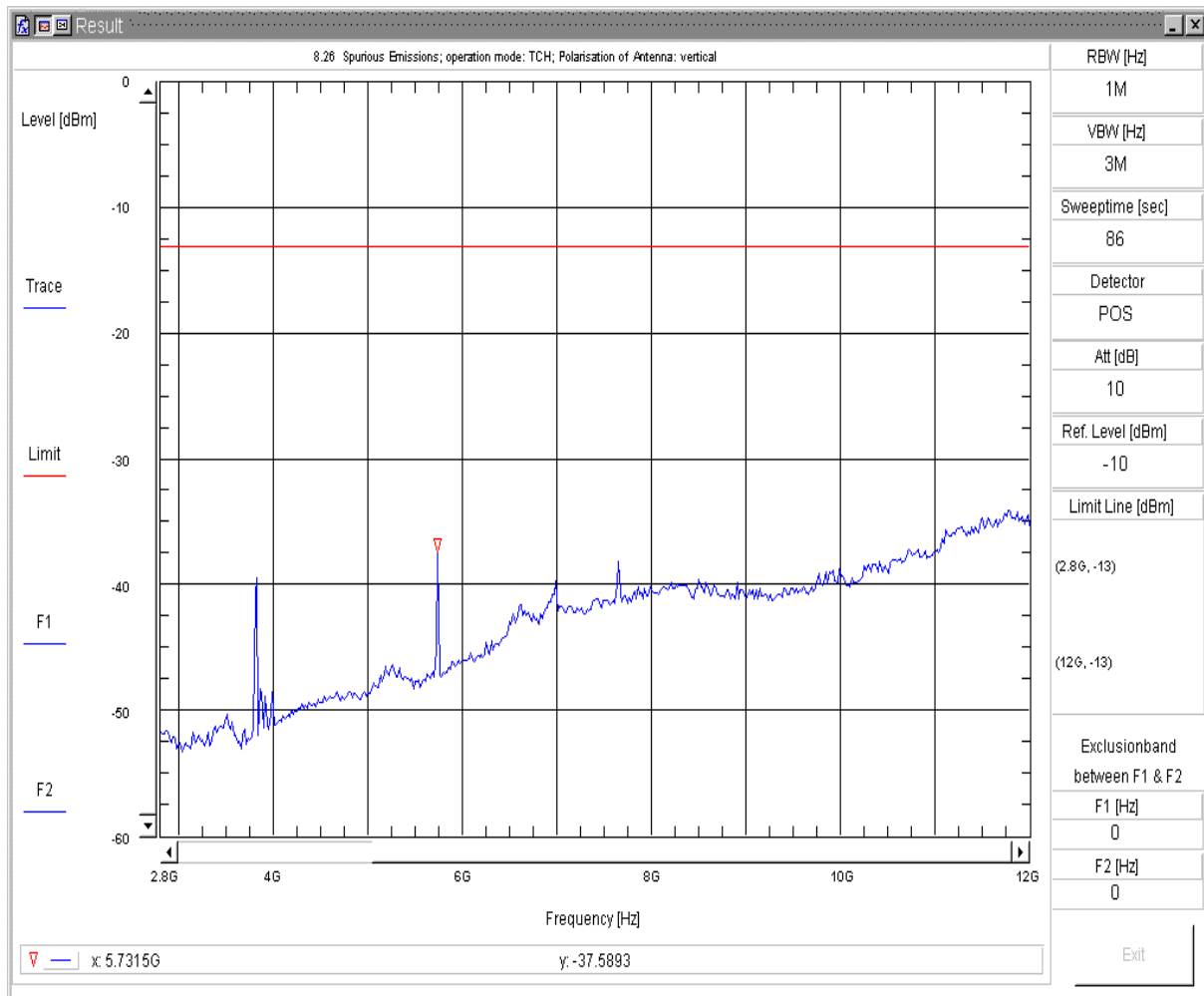

8.26 Radiated Spurious Emission

Transducer: c:\vee_user\spuri_V7\FCC_Part_24.238_(GSM_1900)\TD_TX_V
 Sweepnr: Sweep5
 Pol. of Antenna: vertikal
 EUT Position: EUT_vertical+horizontal
 EUT OP Mode: FCC_Part_24.238_(GSM_1900) TCH
 EUT Description: BGS2-W GSM Module
 EUT add. Info:
 EUT Hardware: B2
 EUT Software:
 EUT Config:
 EUT S/N: 00440108048446800
 Battery: Power Supply (external); Maximum Voltage; 4.5 VDC
 Remark: ARFCN 810
 Operator: Lor
 Testing Site: Fully Anechoic Room (FAR); CETECOM Essen

Fri 04/Feb/2011 13:20:40pp

Spurious Emissions V7.2.5

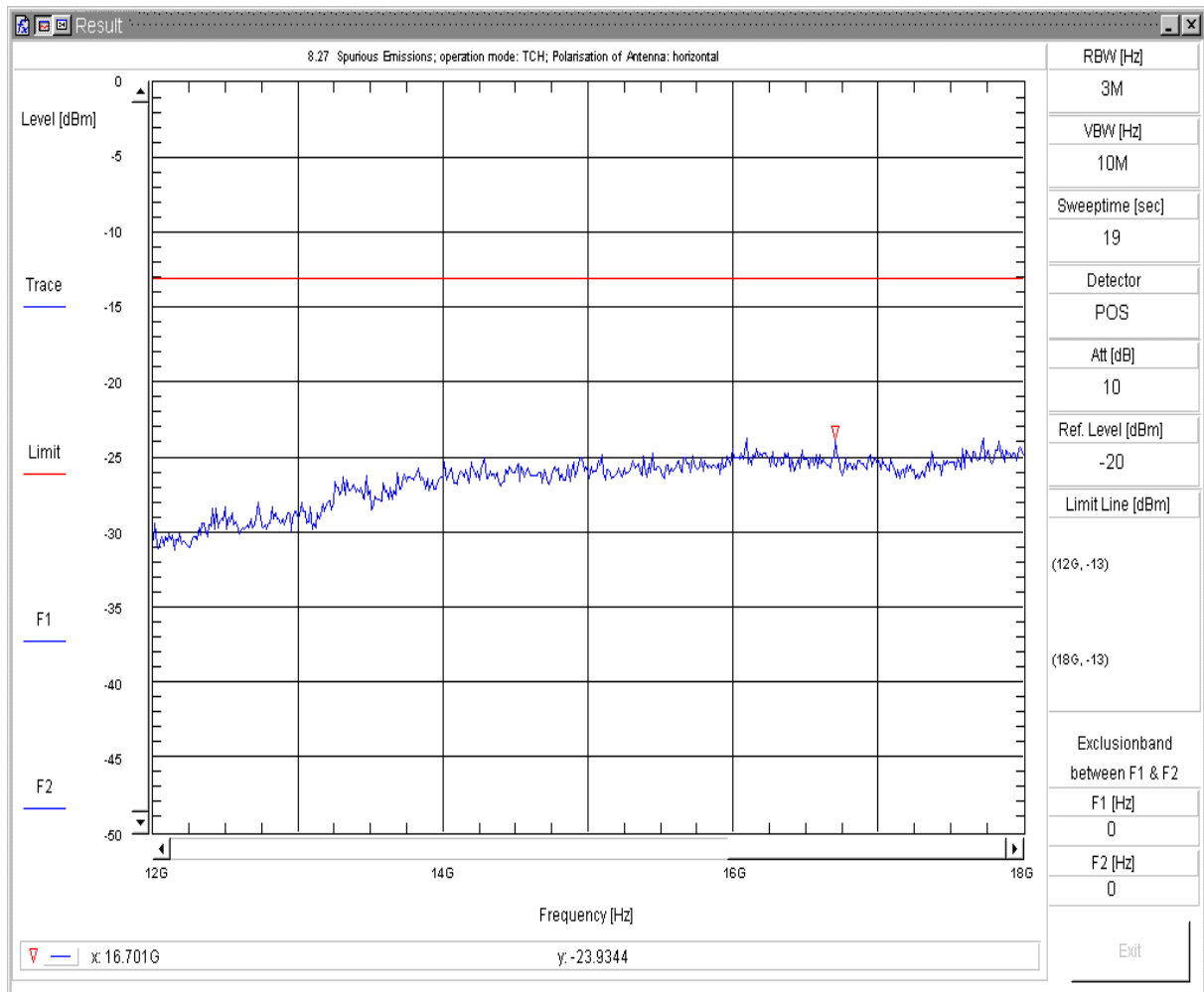

8.27 Radiated Spurious Emission

Transducer: c:\vee_user\spuri_V7\FCC_Part_24.238_(GSM_1900)\TD_TX_H
 Sweepnr: Sweep6
 Pol. of Antenna: horizontal
 EUT Position: EUT_vertical+horizontal
 EUT OP Mode: FCC_Part_24.238_(GSM_1900) TCH
 EUT Description: BGS2-W GSM Module
 EUT add. Info:
 EUT Hardware: B2
 EUT Software:
 EUT Config:
 EUT S/N: 00440108048446800
 Battery: Power Supply (external); Maximum Voltage; 4.5 VDC
 Remark: ARFCN 810
 Operator: Tas
 Testing Site: Fully Anechoic Room (FAR); CETECOM Essen

Fri 04/Feb/2011 13:54:52pp

Spurious Emissions V7.2.5

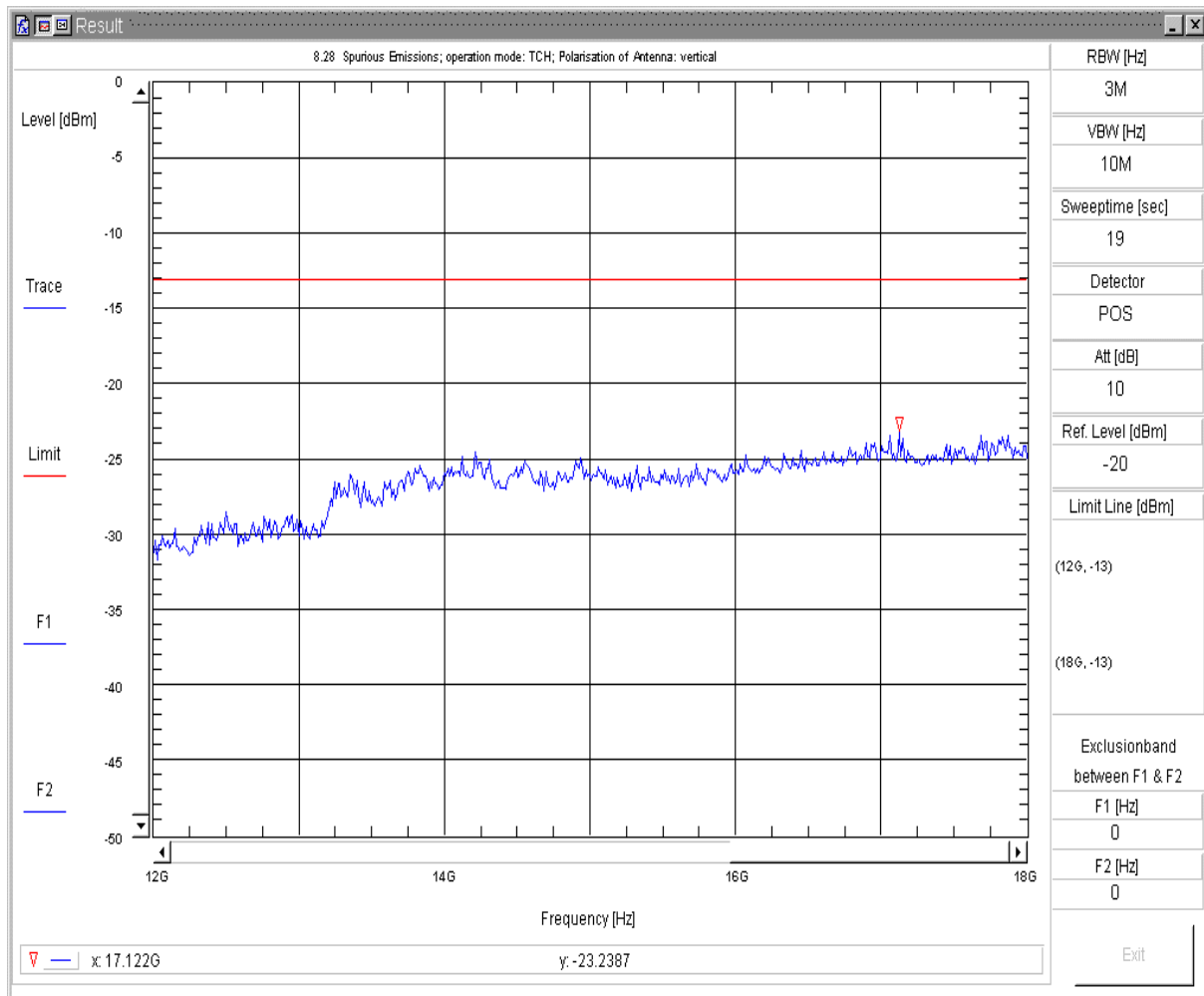

8.28 Radiated Spurious Emission

Transducer: c:\vee_user\spuri_V7\FCC_Part_24.238_(GSM_1900)\TD_TX_V
 Sweepnr: Sweep6
 Pol. of Antenna: vertikal
 EUT Position: EUT_vertical+horizontal
 EUT OP Mode: FCC_Part_24.238_(GSM_1900) TCH
 EUT Description: BGS2-W GSM Module
 EUT add. Info:
 EUT Hardware: B2
 EUT Software:
 EUT Config:
 EUT S/N: 00440108048446800
 Battery: Power Supply (external); Maximum Voltage; 4.5 VDC
 Remark: ARFCN 810
 Operator: Tas
 Testing Site: Fully Anechoic Room (FAR); CETECOM Essen

Fri 04/Feb/2011 13:47:27pp

Spurious Emissions V7.2.5

1.7. Radiated emissions in the frequency range above 18GHz – GSM1900 Mode

Diagram 8.51 – Channel 512 (Overview measurement only)

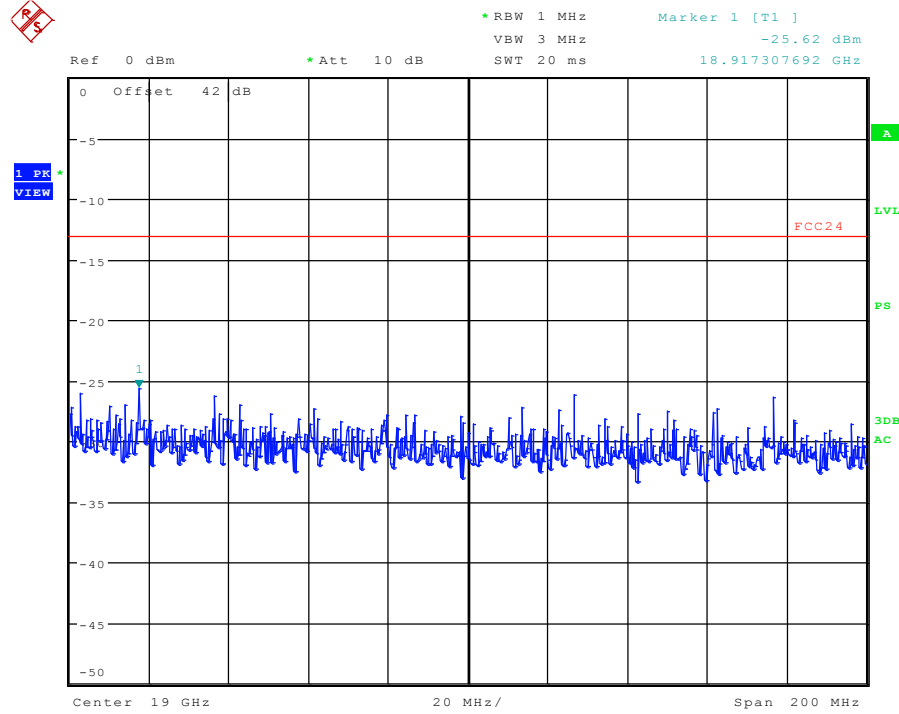

Date: 24.FEB.2011 12:53:02

Diagram 8.52 – Channel 661 (Overview measurement only)

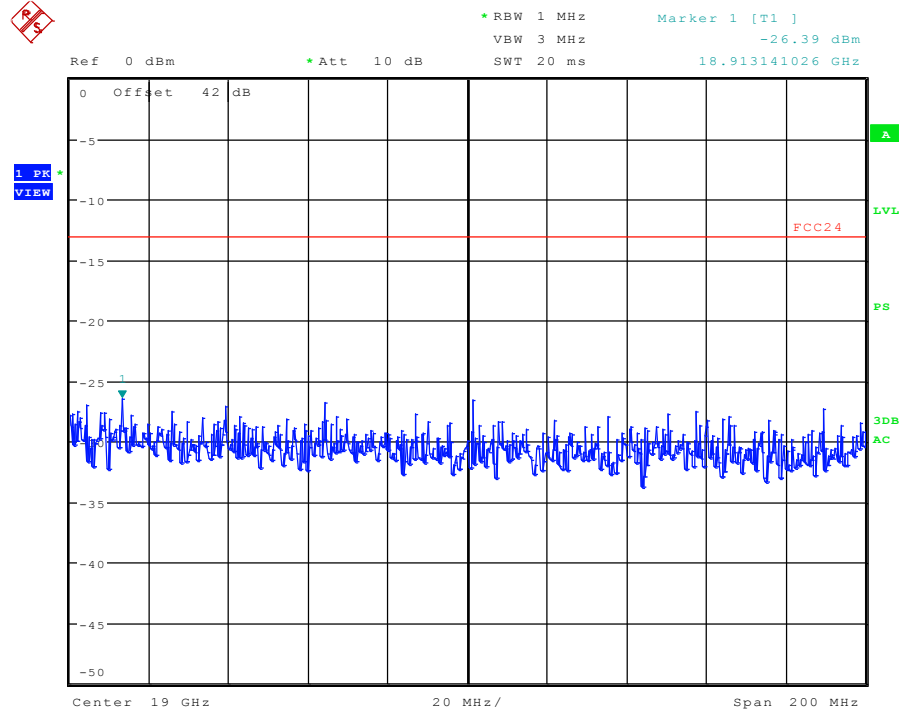

Date: 24.FEB.2011 12:52:01

Diagram 8.53 – Channel 810 (Overview measurement only)

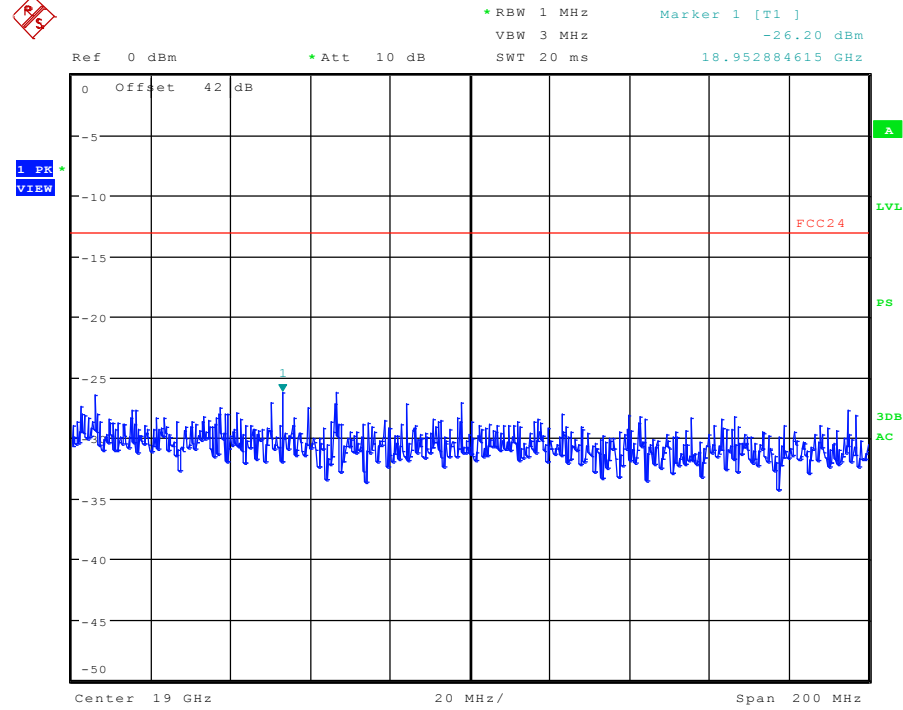

Date: 24.FEB.2011 12:53:50

1.8. Radiated magnetic field strength measurements (f<30MHz)

Diagram No. 03.01

Common Information

Test description:	Magnetic Fieldstrength Measurement related to 3 m distance
Test site and distance:	Semi Anechoic Room (SAR) with 3 m measurement distance
Measured sides of EUT:	front, right, rear, left
Rec. antenna (pre-scan):	height 1.00 m, parallel and 90° to EUT polarisation
Turntable step:	90° during pre-scan
Used filter:	bypass
Test specification.:	FCC 15.205 § 15.209

Operator:	Lor
Comment 1:	Channel low=512

EUT Information

EUT type	BGS2-W+DSB45+Handset Votronic+Ext.Antenna Minimag+RS232+USB cable
Manufacturer	Cinterion
Operating mode	Audio mode TX 1900
S/N	004401-08-048449-2

FCC15.209_magn hor+vert

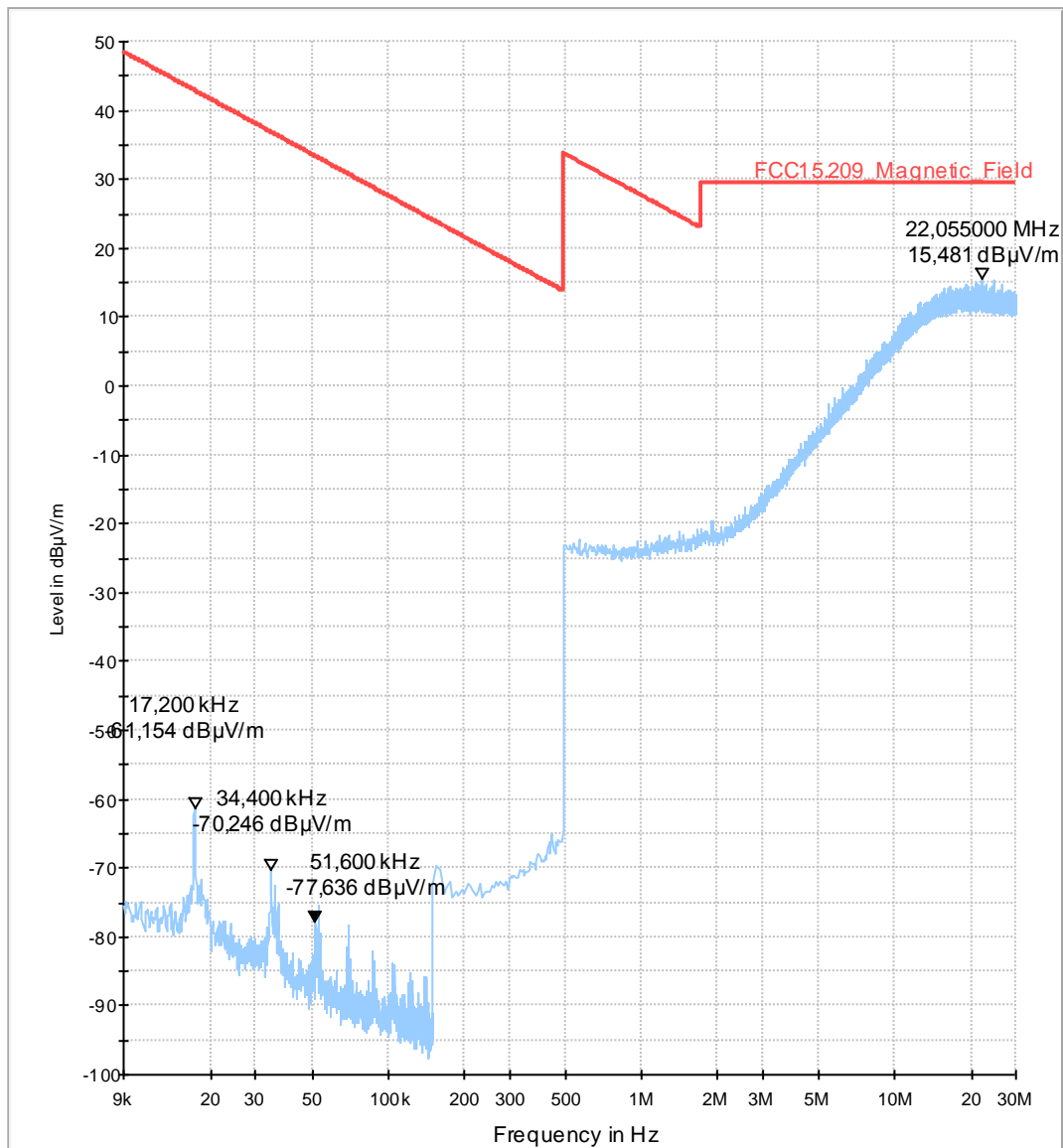

EMI Auto Test Template: FCC15.209_magn hor+vert

Hardware Setup: HW25_FCC15109_ESCS_MgFeld_ohne_SAR_MATRIX
 Measurement Type: Open-Area-Test-Site
 Frequency Range: 9 kHz - 30 MHz
 Graphics Level Range: -100 dB μ V/m - 50 dB μ V/m

Preview Measurements:
 Antenna height: 1000 - 1000 cm , Step Size = 0 cm , Positioning Speed = 1
 Polarization: H + V
 Turntable position: 35 - 305 deg , Step Size = 90 deg , Positioning Speed = 8
 Scan Test Template: 01_FCC_MG_FELD_PK_FAST_H&V_EUT

Subrange	Step Size	Detectors	IF BW	Meas. Time	Preamp
9 kHz - 150 kHz	100 Hz	PK+	200 Hz	0,01 s	0 dB
150 kHz - 30 MHz	5 kHz	PK+	10 kHz	0,01 s	0 dB

Receiver: [ESS]

Data Reduction:
 Limit Line #1: FCC15.209_Magnetic_Field
 Peak Search: 20 dB , Maximum Results: 10
 Subrange Maxima: 10 Subranges , Maxima per Subrange: 1
 Acceptance Offset: -10 dB
 Maximum Number of Results: 10
 After Data Reduction: Interactive data reduction

Adjustment:
 Antenna height: Adjustment with full Range , Measuring Speed = 1
 Turntable position: Adjustment with full Range , Measuring Speed = 3
 Template for Single Meas.: 01_FCC_MG_FELD_PK_FAST_H&V_EUT

Subrange	Step Size	Detectors	IF BW	Meas. Time	Preamp
9 kHz - 150 kHz	100 Hz	PK+	200 Hz	0,01 s	0 dB
150 kHz - 30 MHz	5 kHz	PK+	10 kHz	0,01 s	0 dB

Receiver: [ESS]

Final Measurements:
 Template for Single Meas.: 02_FCC_MG_FELD_QP_final_H&V_EUT

Subrange	Step Size	Detectors	IF BW	Meas. Time	Preamp
9 kHz - 150 kHz	100 Hz	QPK	200 Hz	1 s	0 dB
150 kHz - 30 MHz	5 kHz	QPK	10 kHz	1 s	0 dB

Receiver: [ESS]

Report Settings:
 Report Template: FCC15_209_magn_vert_hor
 Create Electronic Report: PDF
 Document Name: EMI Report

Actions:
 Data Reduction: Before
 Notify: Sound (WAV file) 'tada.wav'
 Final Measurements: After
 Notify: Sound (WAV file) 'tada.wav'

Diagram No. 03.02

Common Information

Test description:	Magnetic Fieldstrength Measurement related to 3 m distance
Test site and distance:	Semi Anechoic Room (SAR) with 3 m measurement distance
Measured sides of EUT:	front, right, rear, left
Rec. antenna (pre-scan):	height 1.00 m, parallel and 90° to EUT polarisation
Turntable step:	90° during pre-scan
Used filter:	bypass
Test specification.:	FCC 15.205 § 15.209
Operator:	Lor
Comment 1:	Channel middle=661

EUT Information

EUT type	BGS2-W+DSB45+Handset Votronic+Ext.Antenna Minimag+RS232+USB cable
Manufacturer	Cinterion
Operating mode	Audio mode TX 1900
S/N	004401-08-048449-2

FCC15.209_magn hor+vert

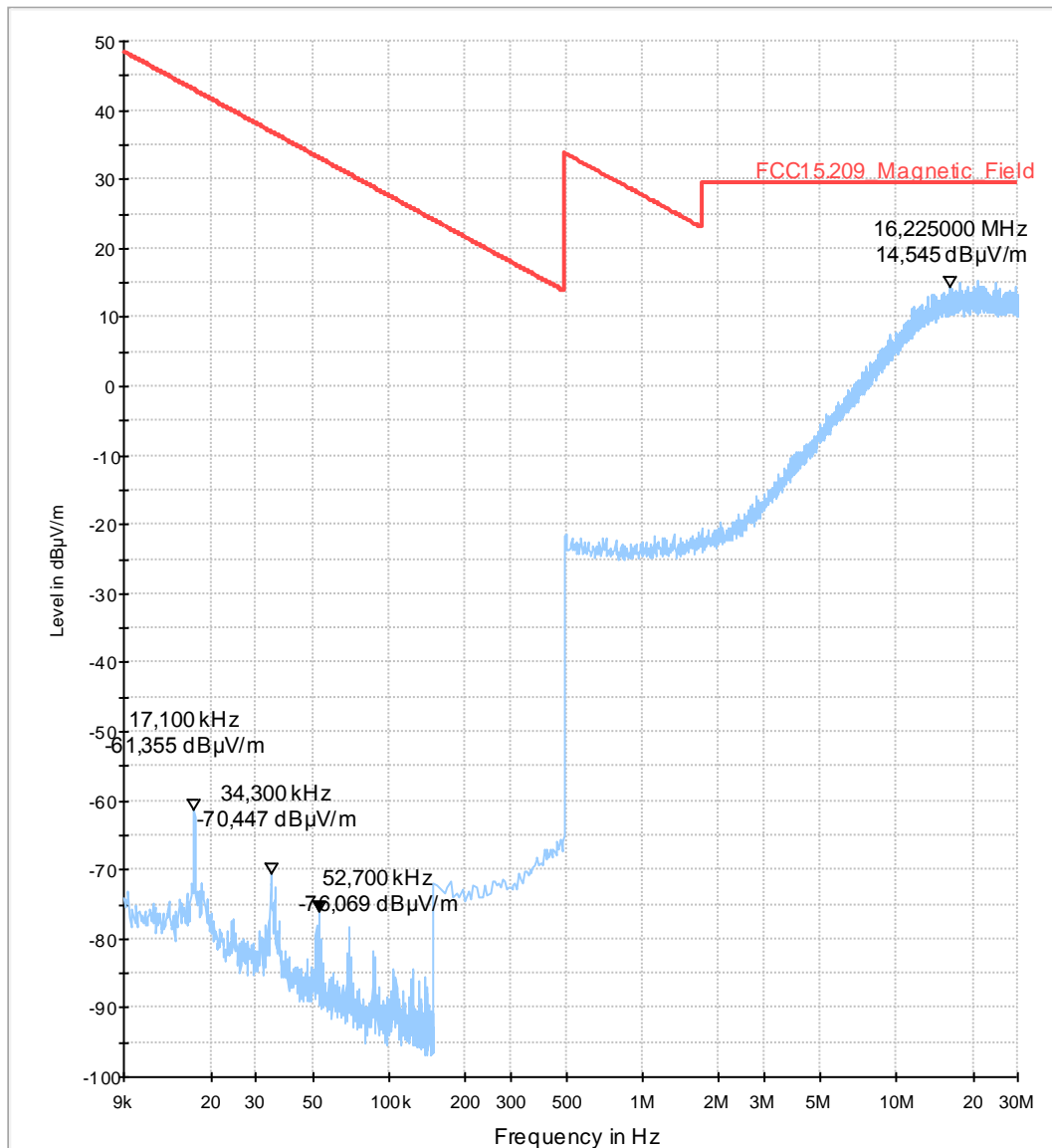



EMI Auto Test Template: FCC15.209_magn hor+vert

Hardware Setup: HW25_FCC15109_ESCS_MgFeld_ohne_SAR_MATRIX
 Measurement Type: Open-Area-Test-Site
 Frequency Range: 9 kHz - 30 MHz
 Graphics Level Range: -100 dBµV/m - 50 dBµV/m

Preview Measurements:
 Antenna height: 1000 - 1000 cm , Step Size = 0 cm , Positioning Speed = 1
 Polarization: H + V
 Turntable position: 35 - 305 deg , Step Size = 90 deg , Positioning Speed = 8
 Scan Test Template: 01_FCC_MG_FELD_PK_FAST_H&V_EUT

Subrange	Step Size	Detectors	IF BW	Meas. Time	Preamp
9 kHz - 150 kHz	100 Hz	PK+	200 Hz	0,01 s	0 dB
150 kHz - 30 MHz	5 kHz	PK+	10 kHz	0,01 s	0 dB

Receiver: [ESS]

Data Reduction:
 Limit Line #1: FCC15.209_Magnetic_Field
 Peak Search: 20 dB , Maximum Results: 10
 Subrange Maxima: 10 Subranges , Maxima per Subrange: 1
 Acceptance Offset: -10 dB
 Maximum Number of Results: 10
 After Data Reduction: Interactive data reduction

Adjustment:
 Antenna height: Adjustment with full Range , Measuring Speed = 1
 Turntable position: Adjustment with full Range , Measuring Speed = 3
 Template for Single Meas.: 01_FCC_MG_FELD_PK_FAST_H&V_EUT

Subrange	Step Size	Detectors	IF BW	Meas. Time	Preamp
9 kHz - 150 kHz	100 Hz	PK+	200 Hz	0,01 s	0 dB
150 kHz - 30 MHz	5 kHz	PK+	10 kHz	0,01 s	0 dB

Receiver: [ESS]

Final Measurements:
 Template for Single Meas.: 02_FCC_MG_FELD_QP_final_H&V_EUT

Subrange	Step Size	Detectors	IF BW	Meas. Time	Preamp
9 kHz - 150 kHz	100 Hz	QPK	200 Hz	1 s	0 dB
150 kHz - 30 MHz	5 kHz	QPK	10 kHz	1 s	0 dB

Receiver: [ESS]

Report Settings:
 Report Template: FCC15_209_magn_vert_hor
 Create Electronic Report: PDF
 Document Name: EMI Report

Actions:
 Data Reduction: Before
 Notify: Sound (WAV file) 'tada.wav'
 Final Measurements: After
 Notify: Sound (WAV file) 'tada.wav'

Diagram No. 03.03

Common Information

Test description:	Magnetic Fieldstrength Measurement related to 3 m distance
Test site and distance:	Semi Anechoic Room (SAR) with 3 m measurement distance
Measured sides of EUT:	front, right, rear, left
Rec. antenna (pre-scan):	height 1.00 m, parallel and 90° to EUT polarisation
Turntable step:	90° during pre-scan
Used filter:	bypass
Test specification.:	FCC 15.205 § 15.209
Operator:	Lor
Comment 1:	Channel high=810

EUT Information

EUT type	BGS2-W+DSB45+Handset Votronic+Ext.Antenna Minimag+RS232+USB cable
Manufacturer	Cinterion
Operating mode	Audio mode TX 1900
S/N	004401-08-048449-2

FCC15.209_magn hor+vert

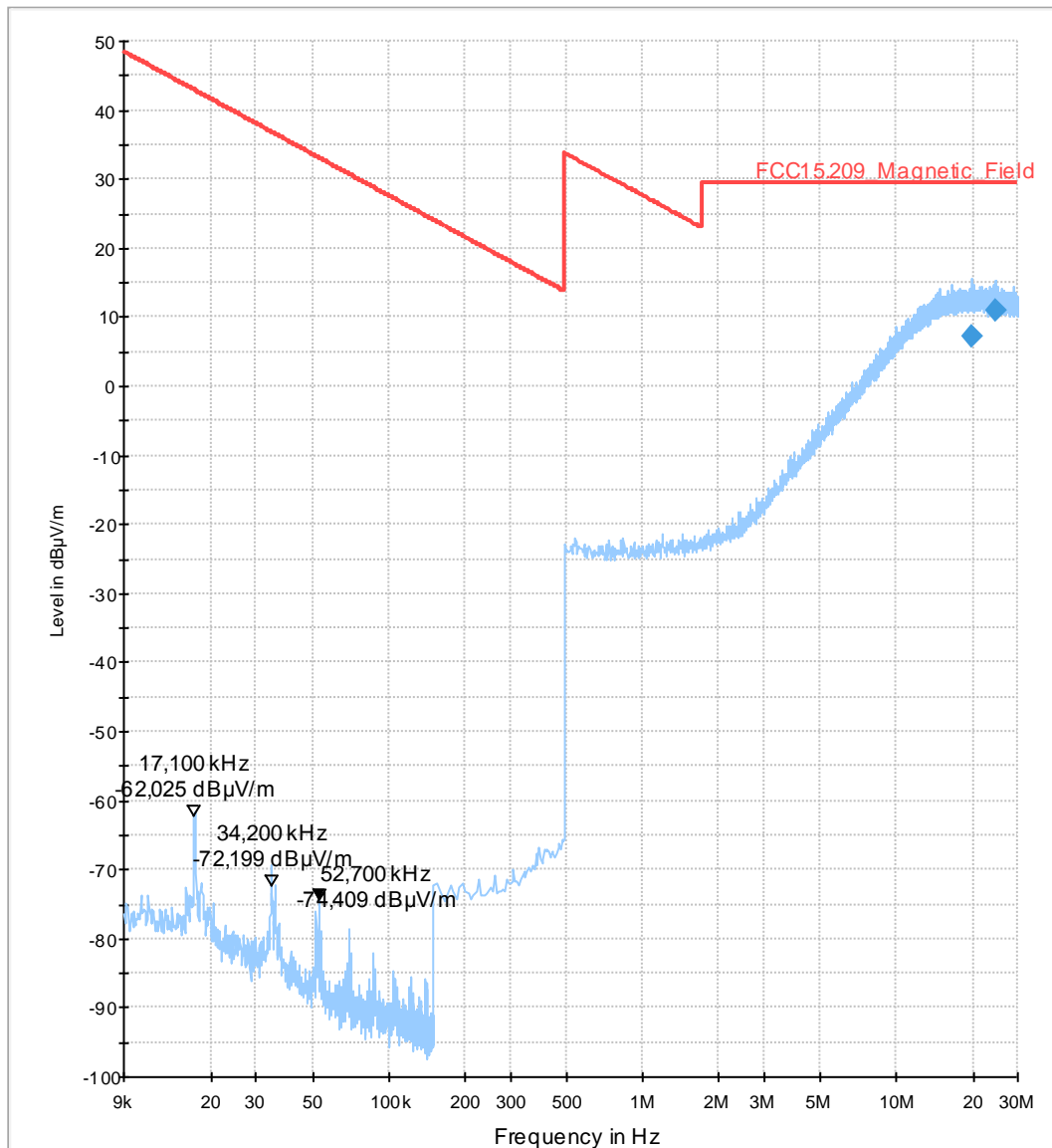

Final Result 1

Frequency (MHz)	QuasiPeak (dBµV/m)	Meas. Time (ms)	Bandwidth (kHz)	Polarization	Azimuth (deg)	Corr. (dB)	Margin (dB)	Limit (dBµV/m)	Comment
19.690000	7.2	1000.0	10.000	V	151.0	2.8	22.34	29.54	
24.575000	11.1	1000.0	10.000	H	124.0	2.8	18.44	29.54	

EMI Auto Test Template: FCC15.209_magn hor+vert

Hardware Setup: HW25_FCC15109_ESCS_MgFeld_ohne_SAR_MATRIX
 Measurement Type: Open-Area-Test-Site
 Frequency Range: 9 kHz - 30 MHz
 Graphics Level Range: -100 dBµV/m - 50 dBµV/m

Preview Measurements:
 Antenna height: 1000 - 1000 cm , Step Size = 0 cm , Positioning Speed = 1
 Polarization: H + V
 Turntable position: 35 - 305 deg , Step Size = 90 deg , Positioning Speed = 8
 Scan Test Template: 01_FCC_MG_FELD_PK_FAST_H&V_EUT

Subrange	Step Size	Detectors	IF BW	Meas. Time	Preamp
9 kHz - 150 kHz	100 Hz	PK+	200 Hz	0,01 s	0 dB
150 kHz - 30 MHz	5 kHz	PK+	10 kHz	0,01 s	0 dB

Receiver: [ESS]

Data Reduction:
 Limit Line #1: FCC15.209_Magnetic_Field
 Peak Search: 20 dB , Maximum Results: 10
 Subrange Maxima: 10 Subranges , Maxima per Subrange: 1
 Acceptance Offset: -10 dB
 Maximum Number of Results: 10
 After Data Reduction: Interactive data reduction

Adjustment:
 Antenna height: Adjustment with full Range , Measuring Speed = 1
 Turntable position: Adjustment with full Range , Measuring Speed = 3
 Template for Single Meas.: 01_FCC_MG_FELD_PK_FAST_H&V_EUT

Subrange	Step Size	Detectors	IF BW	Meas. Time	Preamp
9 kHz - 150 kHz	100 Hz	PK+	200 Hz	0,01 s	0 dB
150 kHz - 30 MHz	5 kHz	PK+	10 kHz	0,01 s	0 dB

Receiver: [ESS]

Final Measurements:
 Template for Single Meas.: 02_FCC_MG_FELD_QP_final_H&V_EUT

Subrange	Step Size	Detectors	IF BW	Meas. Time	Preamp
9 kHz - 150 kHz	100 Hz	QPK	200 Hz	1 s	0 dB
150 kHz - 30 MHz	5 kHz	QPK	10 kHz	1 s	0 dB

Receiver: [ESS]

Report Settings:
 Report Template: FCC15_209_magn_vert_hor
 Create Electronic Report: PDF
 Document Name: EMI Report

Actions:
 Data Reduction: Before
 Notify: Sound (WAV file) 'tada.wav'
 Final Measurements: After
 Notify: Sound (WAV file) 'tada.wav'

1.9 Conducted emissions on AC-Power lines

Diagram No. 1.2

Common Information

Test Description:	Conducted Voltage Measurement Class B
Testspezifikation:	FCC 15.207
Technical Data:	Please see next page for detailed information
Diagram:	Shows the peak values as a sum of measured ports (N+L1) in maxhold mode
Operator name:	MEL
Report.- Nr.	2-20795542a/11
Operating mode:	GSM 1900 TX-mode (Ch. 661)
Measured on line:	Mains AC L1 and N
Power during test:	110 V AC 60 Hz
Comment 1:	

EUT Information

EUT Name:	BGS2-W+AC/DC Adapter+DSB45+Handset Votronic+RS232+USB+(Notebook)
Manufacturer:	Cinerion
Serial Number:	IMEI #8449

01_Class B_Voltage_PK_QPAV_N_L1

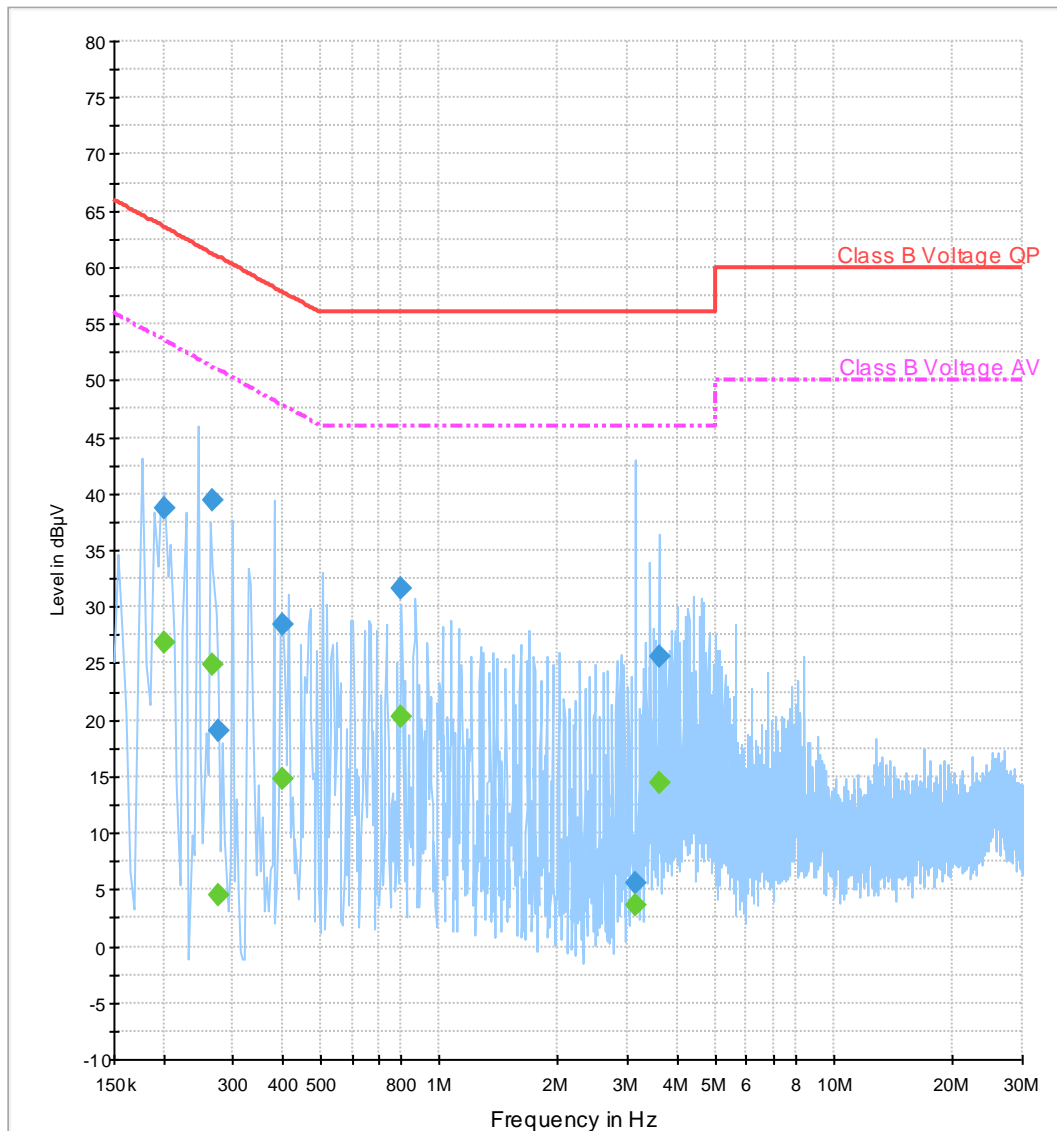

Final Result 1

Frequency (MHz)	QuasiPeak (dBµV)	Meas. Time (ms)	Bandwidth (kHz)	PE	Line	Corr. (dB)	Margin (dB)	Limit (dBµV)
0.199844	38.6	15000.0	9.000	GND	L1	0.0	25.0	63.6
0.266250	39.4	15000.0	9.000	GND	L1	0.1	21.8	61.2
0.275938	19.0	15000.0	9.000	GND	L1	0.0	41.9	60.9
0.402969	28.4	15000.0	9.000	GND	L1	0.0	29.4	57.8
0.799844	31.6	15000.0	9.000	GND	N	0.0	24.4	56.0
3.123594	5.7	15000.0	9.000	GND	L1	0.1	50.4	56.0
3.608906	25.6	15000.0	9.000	GND	L1	0.0	30.4	56.0

Final Result 2

Frequency (MHz)	CAverage (dBµV)	Meas. Time (ms)	Bandwidth (kHz)	PE	Line	Corr. (dB)	Margin (dB)	Limit (dBµV)
0.199844	26.9	15000.0	9.000	GND	L1	0.0	26.7	53.6
0.266250	24.9	15000.0	9.000	GND	L1	0.1	26.3	51.2
0.275938	4.6	15000.0	9.000	GND	L1	0.0	46.3	50.9
0.402969	14.8	15000.0	9.000	GND	L1	0.0	33.0	47.8
0.799844	20.3	15000.0	9.000	GND	N	0.0	25.7	46.0
3.123594	3.7	15000.0	9.000	GND	L1	0.1	42.3	46.0
3.608906	14.5	15000.0	9.000	GND	L1	0.0	31.5	46.0

Technical Data of Measurements with R&S EMC32 V8.40.0

Hardware Setup: EMI conducted\ESH2-Z5 - [EMI conducted]

Subrange 1
 Frequency Range: 150 kHz - 30 MHz
 Receiver: Receiver [ESCS 30]
 @ GPIB0 (ADR 19), SN Ref.-Nr. 377, FW 2.30 02.01 02.36
 Signal Path: ESH2-Z5 Kabeldämpfung
 Correction Table: Conducted Voltage ESH2-Z5 cable loss
 LISN: ESH2-Z5
 Correction Table (Line 0): 4-Line-LISN ESH2-Z5 Line N
 Correction Table (Line 1): 4-Line-LISN ESH2-Z5 Line L1
 Correction Table (Line 2): 4-Line-LISN ESH2-Z5 Line L2
 Correction Table (Line 3): 4-Line-LISN ESH2-Z5 Line L3

EMI Auto Test Template: 01_Class B_Voltage_PK_QPAV_N_L1

Hardware Setup: ESH2-Z5
 Measurement Type: 4 Line LISN
 Frequency Range: 150 kHz - 30 MHz
 Graphics Level Range: -10 dBµV - 80 dBµV

Preview Measurements:
 Scan Test Template: 02_Class B_pre_PK_fast

Subrange	Step Size	Detectors	IF BW	Meas. Time	Preamp
150 kHz - 30 MHz	3.906 kHz	PK+	9 kHz	0,00005 s	0 dB
Receiver: [ESCS 30]					

Data Reduction:
 Limit Line #1: Class B Voltage QP
 Limit Line #2: Class B Voltage AV
 Peak Search: 6 dB , Maximum Results: 10
 Subrange Maxima: 50 Subranges , Maxima per Subrange: 2
 Acceptance Offset: -13 dB
 Maximum Number of Results: 30
 After Data Reduction: Interactive data reduction

Frequency Zoom:
 Zoom Scan Template: 08_Class B_maxZoom_PK100mS

Subrange	Step Size	Detectors	IF BW	Meas. Time	Preamp
150 kHz - 30 MHz	5 kHz	PK+	9 kHz	0,1 s	0 dB
Receiver: [ESCS 30]					

Final Measurements:
 Template for Single Meas.: 07_Class B_fin_AV_QP

Subrange	Step Size	Detectors	IF BW	Meas. Time	Preamp
150 kHz - 30 MHz	4.5 kHz	QPK; CAV	9 kHz	15 s	0 dB
Receiver: [ESCS 30]					

Diagram No. 1.4

Common Information^{Test}

Testspezifikation:

Technical Data:

Diagram:

Operator name:

Operating mode:

Measured on line:

Power during test:

Comment 1:

Conducted Voltage Measurement

FCC 15.207

Please see next page for detailed information

Shows the peak values as a sum of measured ports (N+L1) in maxhold mode

Lor

GSM850, Channel 192

Mains AC L1 and N

110 V AC 60 Hz

--

EUT Information

EUT Name:

Manufacturer:

Serial Number:

BGS2-W+AC/DC Adapter+DSB45+Handset Votronic+RS232+USB+(Notebook)

Cinterion

IMEI #8449

01_Class B_Voltage_PK_QPAV_N_L1

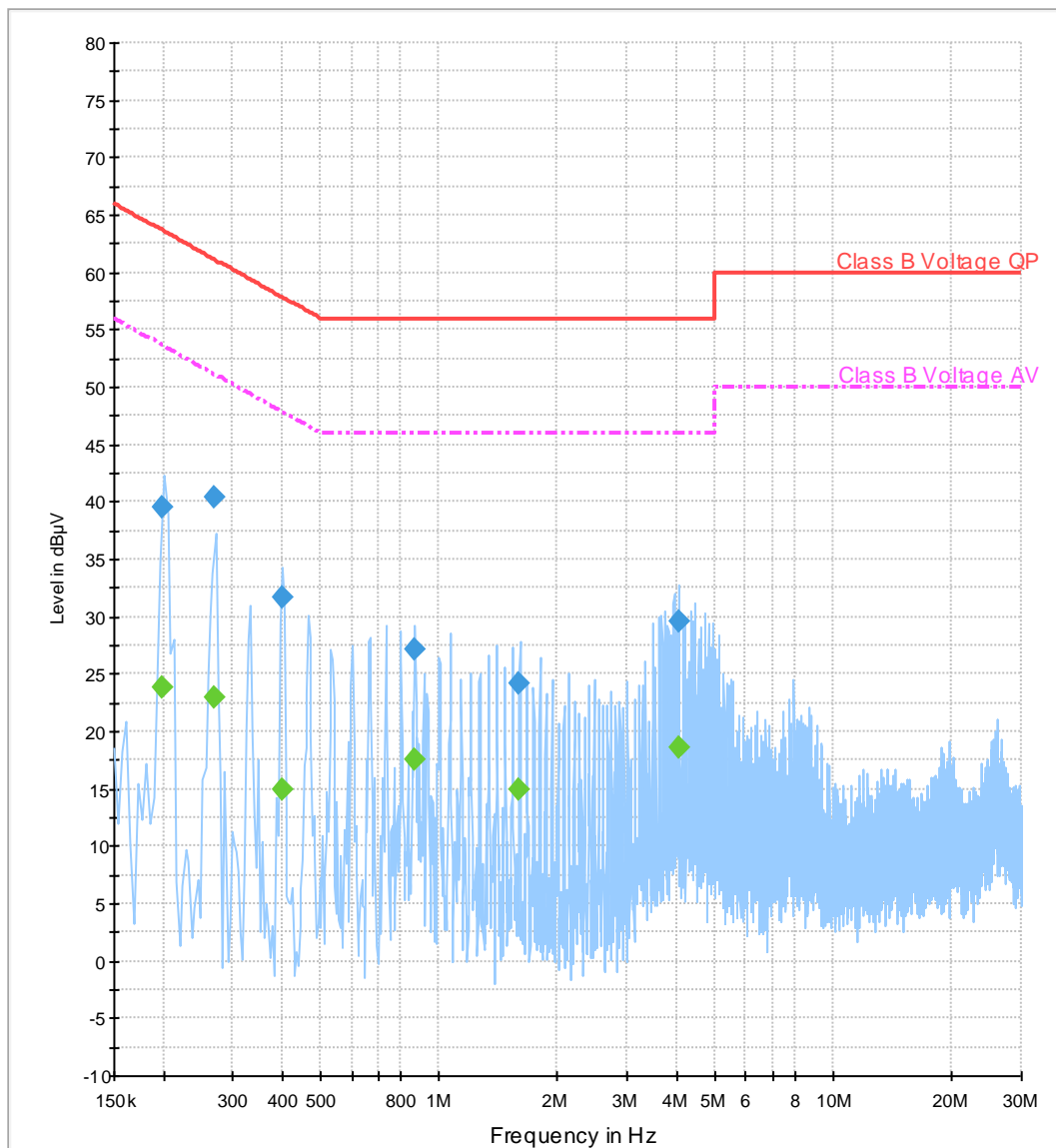

Final Result 1

Frequency (MHz)	QuasiPeak (dBµV)	Meas. Time (ms)	Bandwidth (kHz)	PE	Line	Corr. (dB)	Margin (dB)	Limit (dBµV)
0.198281	39.5	15000.0	9.000	GND	N	0.0	24.2	63.7
0.268594	40.4	15000.0	9.000	GND	L1	0.1	20.8	61.2
0.402500	31.7	15000.0	9.000	GND	L1	0.0	26.1	57.8
0.866250	27.2	15000.0	9.000	GND	N	0.1	28.8	56.0
1.600625	24.3	15000.0	9.000	GND	N	0.1	31.7	56.0
4.073281	29.5	15000.0	9.000	GND	N	0.1	26.5	56.0

Final Result 2

Frequency (MHz)	CAverage (dBµV)	Meas. Time (ms)	Bandwidth (kHz)	PE	Line	Corr. (dB)	Margin (dB)	Limit (dBµV)
0.198281	23.8	15000.0	9.000	GND	N	0.0	29.9	53.7
0.268594	23.0	15000.0	9.000	GND	L1	0.1	28.2	51.2
0.402500	14.9	15000.0	9.000	GND	L1	0.0	32.9	47.8
0.866250	17.6	15000.0	9.000	GND	N	0.1	28.4	46.0
1.600625	15.0	15000.0	9.000	GND	N	0.1	31.0	46.0
4.073281	18.6	15000.0	9.000	GND	N	0.1	27.4	46.0

Technical Data of Measurements with R&S EMC32 V8.40.0**Hardware Setup: EMI conducted\ESH2-Z5 - [EMI conducted]**

Subrange 1

Frequency Range: 150 kHz - 30 MHz

Receiver: Receiver [ESCS 30]
@ GPIB0 (ADR 19), SN Ref.-Nr. 377, FW 2.30 02.01 02.36

Signal Path: ESH2-Z5 Kabeldämpfung
Correction Table: Conducted Voltage ESH2-Z5 cable loss

LISN: ESH2-Z5
Correction Table (Line 0): 4-Line-LISN ESH2-Z5 Line N
Correction Table (Line 1): 4-Line-LISN ESH2-Z5 Line L1
Correction Table (Line 2): 4-Line-LISN ESH2-Z5 Line L2
Correction Table (Line 3): 4-Line-LISN ESH2-Z5 Line L3

EMI Auto Test Template: 01_Class B_Voltage_PK_QPAV_N_L1

Hardware Setup: ESH2-Z5
Measurement Type: 4 Line LISN
Frequency Range: 150 kHz - 30 MHz
Graphics Level Range: -10 dBµV - 80 dBµV

Preview Measurements:

Scan Test Template: 02_Class B_pre_PK_fast

Subrange	Step Size	Detectors	IF BW	Meas. Time	Preamp
150 kHz - 30 MHz	3.906 kHz	PK+	9 kHz	0,00005 s	0 dB

Receiver: [ESCS 30]

Data Reduction:

Limit Line #1: Class B Voltage QP
Limit Line #2: Class B Voltage AV
Peak Search: 6 dB , Maximum Results: 10
Subrange Maxima: 50 Subranges , Maxima per Subrange: 2
Acceptance Offset: -13 dB
Maximum Number of Results: 30
After Data Reduction: Interactive data reduction

Frequency Zoom:

Zoom Scan Template: 08_Class B_maxZoom_PK100mS

Subrange	Step Size	Detectors	IF BW	Meas. Time	Preamp
150 kHz - 30 MHz	5 kHz	PK+	9 kHz	0,1 s	0 dB

Receiver: [ESCS 30]

Final Measurements:

Template for Single Meas.: 07_Class B_fin_AV_QP

Subrange	Step Size	Detectors	IF BW	Meas. Time	Preamp
150 kHz - 30 MHz	4.5 kHz	QPK; CAV	9 kHz	15 s	0 dB

Receiver: [ESCS 30]

Annex 2: EUT Photos
to
TEST REPORT
No.: 2-20795542b/11

According to:
FCC Regulations
FCC Part 22H/24E
FCC Part 15.207C
FCC Part 15.209C
&
IC Regulations
RSS-132, Issue 2
RSS-133, Issue 5
RSS-Gen, Issue 2

for

Cinterion Wireless Modules GmbH

Quad-Band GSM/GPRS Module BGS2-W
FCC-ID: QIPBGS2
IC: 7830A-BGS2







Laboratory Accreditation and Listings			
 D-PL-12047-01-01	 MRA US-EU 0003	 Reg. No.: 3462D-1 3462D-2	 Reg. No.: R-2665, R-2666 C-2914, T-1967 G-301
 LAB CODE 20011130-00	 AUTHORIZED RF LABORATORY	accredited according to DIN EN ISO/IEC 17025	
CETECOM GmbH Laboratory Radio Communications & Electromagnetic Compatibility Im Teelbruch 116 • 45219 Essen • Germany Registered in Essen, Germany, Reg. No.: HRB Essen 8984 Tel.: + 49 (0) 20 54 / 95 19-954 • Fax: + 49 (0) 20 54 / 95 19-964 E-mail: info@cetecom.com • Internet: www.cetecom.com			

Table of contents

1. EUT PHOTOGRAPHS	3
---------------------------------	----------

1. EUT Photographs



Photograph 1: EUT F – top side



Photograph 2: EUT F – rear side



Photograph 3: EUT F – top side PCB with Hirose SMA adapter



Photograph 4: EUT F+ Adapter board for BGS2-W bottom side



Photograph 5: Modules connection (flexible flat ribbon and adapter) to DSB75 Box (EUT D + E)

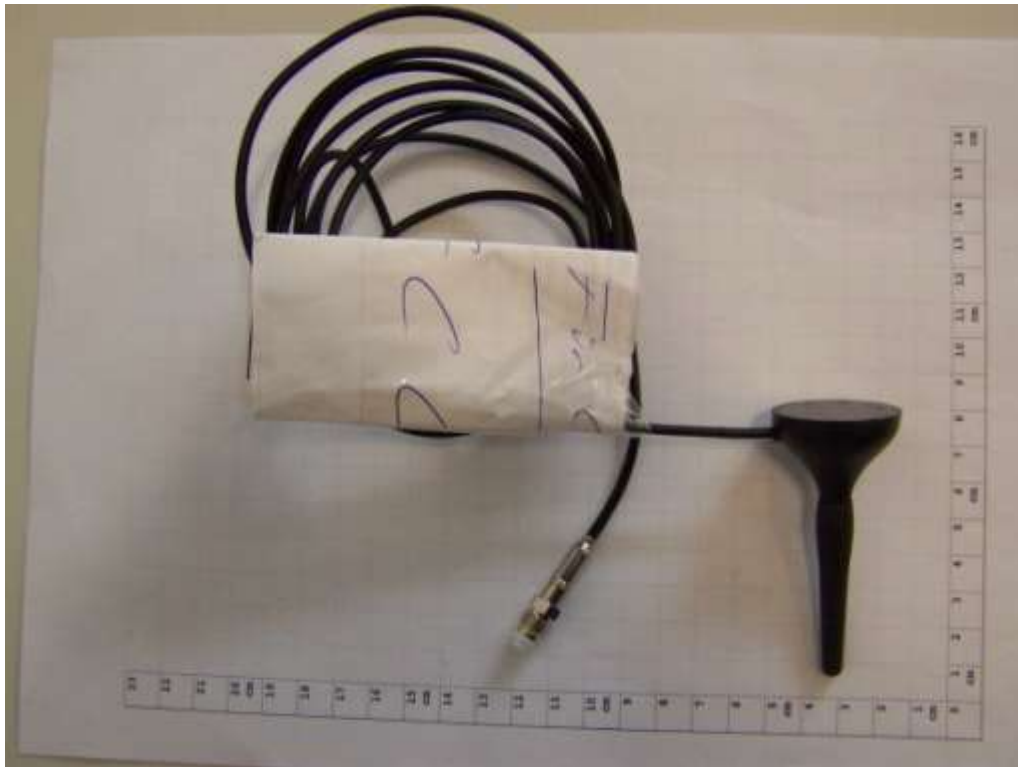

Photograph 6: Magnetic mount antenna (EUT B)



Photograph 7: Handset (EUT C)



Photograph 8: DSB75 Box (rear side of EUT E)

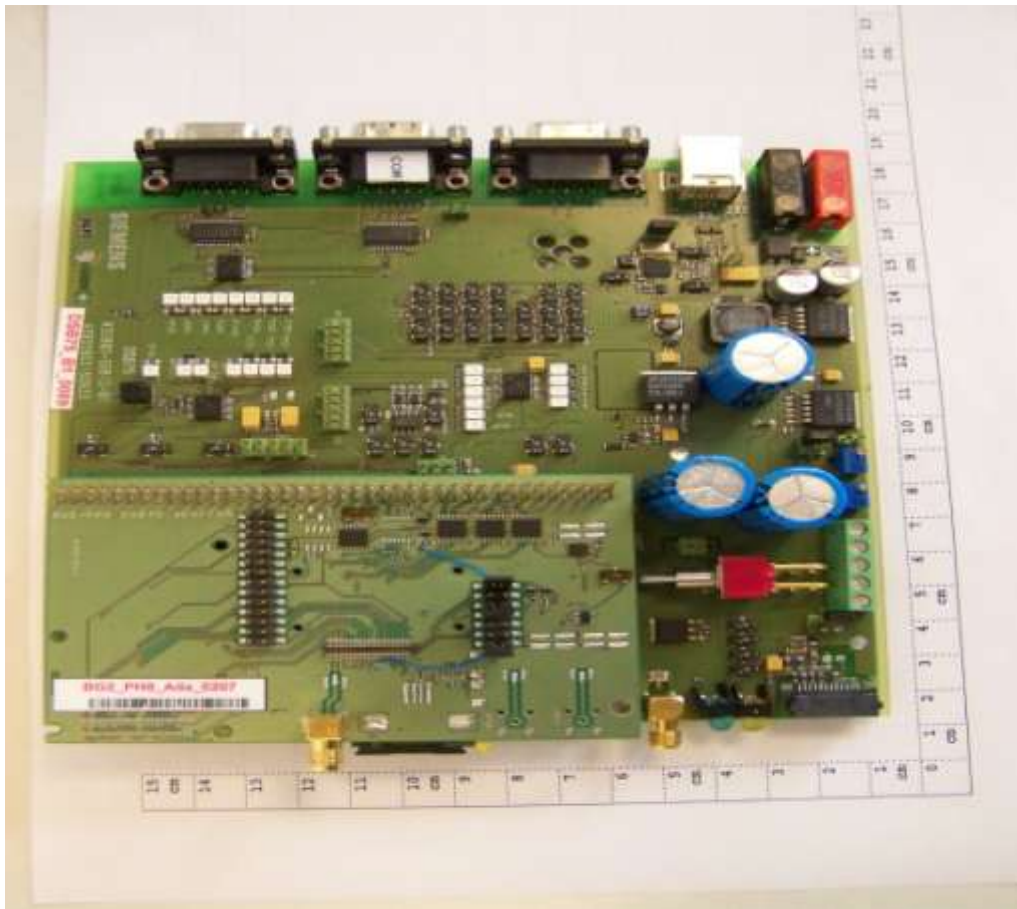

Photograph 9: DSB 75 V1.1 board - top site (EUT E)



Photograph 10: DSB 75 V1.1 board - bottom site (EUT E)

Annex 3: Set-up Photos
to
TEST REPORT
No.: 2-207955424b/11

According to:
FCC Regulations
FCC Part 22H/24E
FCC Part 15.109C
FCC Part 15.209C
&
IC Regulations
RSS-132, Issue 2
RSS-133, Issue 5
RSS-Gen, Issue 2

for

Cinterion Wireless Modules GmbH

Quad-Band GSM/GPRS Module BGS2-W
FCC-ID: QIPBGS2
IC: 7830A-BGS2







Laboratory Accreditation and Listings			
 D-PL-12047-01-01	 MRA US-EU 0003	 Reg. No.: 3462D-1 3462D-2	 Reg. No.: R-2665, R-2666 C-2914, T-1967 G-301
 LAB CODE 20011130-00			
accredited according to DIN EN ISO/IEC 17025			
<p>CETECOM GmbH Laboratory Radio Communications & Electromagnetic Compatibility Im Teelbruch 116 • 45219 Essen • Germany Registered in Essen, Germany, Reg. No.: HRB Essen 8984 Tel.: + 49 (0) 20 54 / 95 19-954 • Fax: + 49 (0) 20 54 / 95 19-964 E-mail: info@cetecom.com • Internet: www.cetecom.com</p>			

Table of contents

1. SET-UP PHOTOGRAPHS3

Total photographs: 4

1. Set-up photographs



Photograph 1: Radiated measurement set-up at SAR (Semi-Anechoic-Room)



Photograph 2: Radiated measurement set-up at FAR (Fully-Anechoic-Room)



Photograph 3: Conducted emissions on AC line measurements

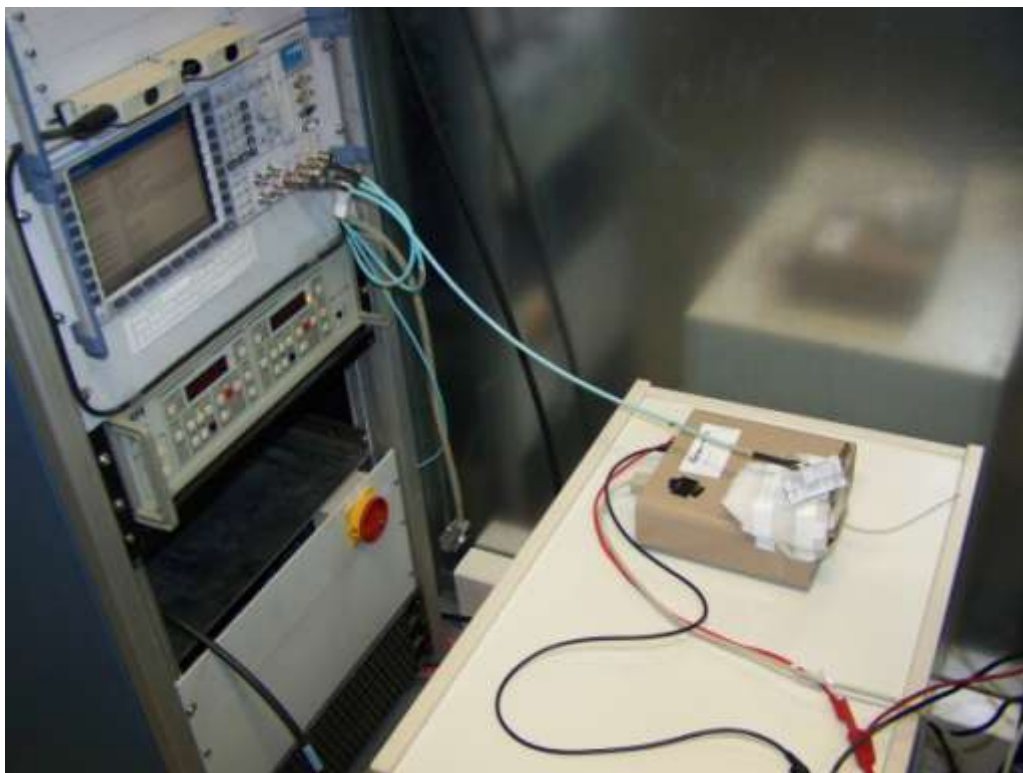

Photograph 4: Conducted maximum output power measurements