

TEST REPORT

of

FCC Part 15 Subpart C §15.247

FCC ID: SS4P1B58

Equipment Under Test : GSM/ WCDMA PDA Phone
with Bluetooth & WLAN

Model Name : BIP-7000

Serial No. : N/A

Applicant : Bluebird Soft, Inc.

Manufacturer : Bluebird Soft, Inc.

Date of Test(s) : 2010.09.30 ~ 2010.10.07

Date of Issue : 2010.11.02

In the configuration tested, the EUT complied with the standards specified above.

Tested By:



Date

2010.11.02

Duke Ko

Approved By



Date

2010.11.02

Charles Kim

The results shown in this test report refer only to the sample(s) tested unless otherwise stated. This test report cannot be reproduced, except in full, without prior written permission of the Company.

INDEX

Table of contents

1. General information -----	3
2. Transmitter radiated spurious emissions and conducted spurious emission -----	6
3. 6 dB bandwidth -----	20
4. Maximum peak output power -----	25
5. Power Spectral Density -----	27
6. Transmitter AC Power Line Conducted Emission-----	32
7. Antenna Requirement -----	37

The results shown in this test report refer only to the sample(s) tested unless otherwise stated. This test report cannot be reproduced, except in full, without prior written permission of the Company.

1. General Information

1.1. Testing Laboratory

SGS Testing Korea Co., Ltd.

- Wireless Div. 2FL, 18-34, Sanbon-dong, Gunpo-si, Gyeonggi-dong, Korea

- 705, Dongcheon-dong Suji-gu, Yongin-si, Gyeonggi-do, Korea

www.electrolab.kr.sgs.com

Telephone : +82 +31 428 5700

FAX : +82 +31 427 2371

1.2. Details of Applicant

Applicant : Bluebird Soft, Inc.

Address : 1242, Gaepo-dong, Kangnam-gu, Seoul, Korea

Contact Person : In-Gu Kim

Phone No. : +82 +70 7730 8252

Fax No. : +82 +2 548 0870

1.3. Description of EUT

Kind of Product	GSM/WCDMA PDA Phone with Bluetooth & WLAN
Model Name	BIP-7000
Serial Number	N/A
Power Supply	DC 3.7 V (Li-ion Battery)
Frequency Range	2 412 ~ 2 462 MHz (802.11b/g)
Modulation Technique	DSSS, OFDM
Number of Channels	11
Antenna Type	Integral Type (Chip Antenna)
Antenna Gain	1.81 dBi

1.4. Declaration by the manufacturer

- WLAN & BT cannot transmit simultaneously.

The results shown in this test report refer only to the sample(s) tested unless otherwise stated. This test report cannot be reproduced, except in full, without prior written permission of the Company.

1.5. Test Equipment List

EQUIPMENT	MANUFACTURER	MODEL	CAL DUE.
Signal Generator	Rohde & Schwarz	SMR40	Jul. 15, 2011
Spectrum Analyzer	Rohde & Schwarz	FSV30	May 31, 2011
Power Sensor	Rohde & Schwarz	NRP-Z81	Aug. 14, 2011
Preamplifier	H.P	8447F	Jul. 05, 2011
Preamplifier	Agilent	8449B	Apr. 01, 2011
High Pass Filter	Wainwright	WHK3.0/18G-10SS	Sep. 29, 2011
Test Receiver	Rohde & Schwarz	ESU26	Apr. 08, 2011
Bilog Antenna	SCHWARZBECK MESSELEKTRONIK	VULB9163	Jul. 22, 2011
Horn Antenna	Rohde & Schwarz	HF 906	Oct. 08, 2011
Horn Antenna	SCHWARZBECK MESSELEKTRONIK	BBHA9170	Mar. 17 2012
Anechoic Chamber	SY Corporation	L x W x H (9.6 m x 6.4 m x 6.6 m)	Jan. 27, 2011
Two-Line V-Network	Rohde & Schwarz	ENV216	Jan. 06, 2011
Test Receiver	Rohde & Schwarz	ESHS10	Jul. 13, 2011
Anechoic Chamber	SY Corporation	L x W x H (6.5 m x 3.5 m x 3.5 m)	N.C.R

The results shown in this test report refer only to the sample(s) tested unless otherwise stated. This test report cannot be reproduced, except in full, without prior written permission of the Company.

1.6. Summary of Test Results

The EUT has been tested according to the following specifications:

APPLIED STANDARD:FCC Part15 subpart B&C		
Standard section	Test Item	Result
15.205(a) 15.209 15.247(d)	Transmitter Radiated Spurious Emissions Conducted Spurious Emission	Complied
15.109(a)	Receiver Radiated Spurious Emission	Complied
15.247(a)(2)	6 dB Bandwidth	Complied
15.247(b)(3)	Maximum Peak Output Power	Complied
15.247(e)	Power Spectral Density	Complied
15.207	Transmitter AC Power Line Conducted Emission	Complied

1.7. Conclusion of worst-case

The field strength of spurious emission was measured in three orthogonal EUT positions(x-axis, y-axis and z-axis). Worst case is z-axis. 1 Mbps is the highest output power in the 11b. 6 Mbps is the highest output power in the 11g.

1.8 Test report revision

Revision	Report number	Description
0	F690501/RF-RTL004249	Initial

The results shown in this test report refer only to the sample(s) tested unless otherwise stated. This test report cannot be reproduced, except in full, without prior written permission of the Company.

2. Transmitter Radiated Spurious Emissions and Conducted Spurious Emission

2.1. Test Setup

2.1.1. Transmitter Radiated Spurious Emissions

The diagram below shows the test setup that is utilized to make the measurements for emission from 30 MHz to 1 GHz Emissions.

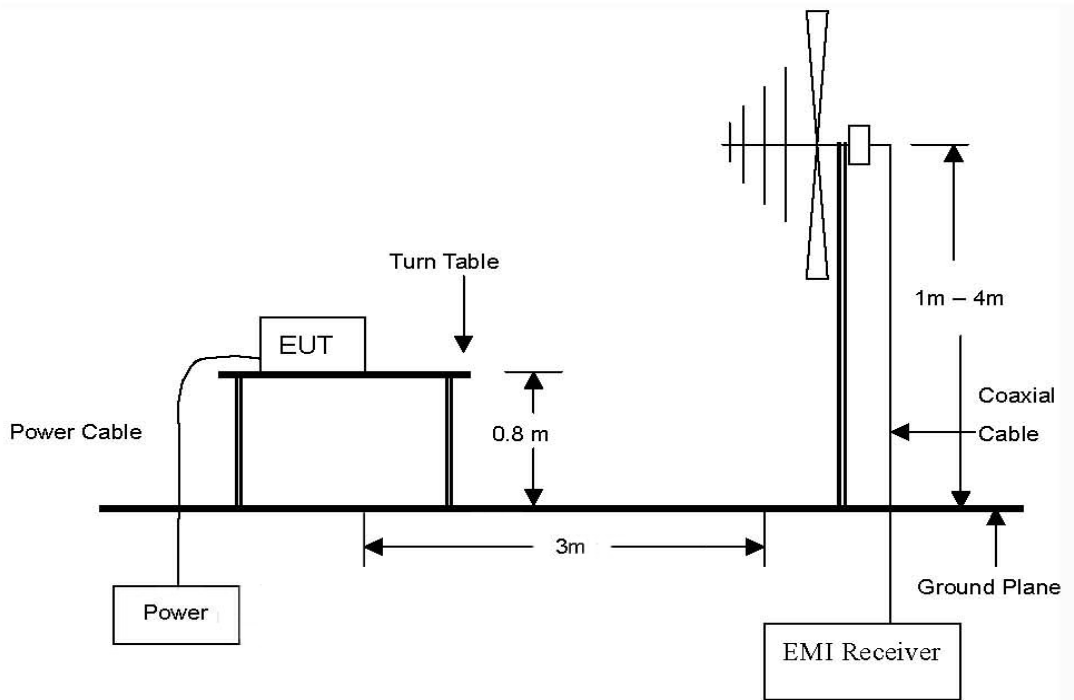

The diagram below shows the test setup that is utilized to make the measurements for emission from 1 GHz to 24 GHz Emissions.

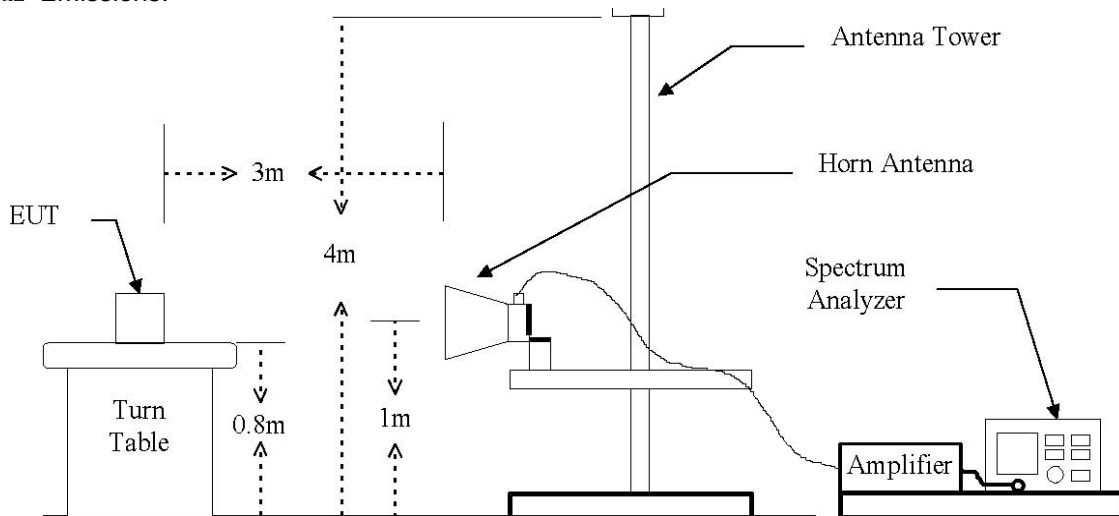

The results shown in this test report refer only to the sample(s) tested unless otherwise stated. This test report cannot be reproduced, except in full, without prior written permission of the Company.

2.1.2. Conducted Spurious Emission

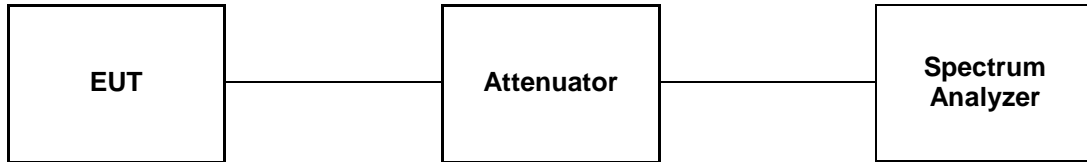

2.2. Limit

According to §15.247(d), in any 100 kHz bandwidth outside the frequency band in which the spread spectrum or digitally modulated intentional radiator is operating, the radio frequency power that is produced by the intentional radiator shall be at least 20 dB below that in the 100 kHz bandwidth within the band that contains the highest level of the desired power, based on either an RF conducted or a radiated measurement, provided the transmitter demonstrates compliance with the peak conducted power limits. If the transmitter complies with the conducted power limits based on the use of RMS averaging over a time interval, as permitted under paragraph(b)(3) of this section, the attenuation required under this paragraph shall be 30 dB instead of 20 dB. Attenuation below the general limits specified in section §15.209(a) is not required. In addition, radiated emission which in the restricted band, as define in section §15.205(a), must also comply the radiated emission limits specified in section §15.209(a) (see section §15.205(c))

According to § 15.209(a), Except as provided elsewhere in this Subpart, the emissions from an intentional radiator shall not exceed the field strength levels specified in the following table :

Frequency (MHz)	Distance (Meters)	Field Strength (dB μ V/m)	Field Strength (μ V/m)
30 - 88	3	40.0	100
88 – 216	3	43.5	150
216 – 960	3	46.0	200
Above 960	3	54.0	500

The results shown in this test report refer only to the sample(s) tested unless otherwise stated. This test report cannot be reproduced, except in full, without prior written permission of the Company.

2.3. Test Procedures

Radiated emissions from the EUT were measured according to the dictates of ANSI C63.4:2003

2.3.1. Test Procedures for Radiated Spurious Emissions

1. The EUT was placed on the top of a rotating table 0.8 meters above the ground at a 3 meter anechoic chamber test site. The table was rotated 360 degrees to determine the position of the highest radiation.
2. During performing radiated emission below 1 GHz, the EUT was set 3 meters away from the interference receiving antenna, which was mounted on the top of a variable-height antenna tower. During performing radiated emission above 1 GHz, the EUT was set 3 meter away from the interference-receiving antenna.
3. The antenna is a broadband antenna, and its height is varied from one meter to four meters above the ground to determine the maximum value of the field strength. Both horizontal and vertical polarizations of the antenna are set to make the measurement.
4. For each suspected emission, the EUT was arranged to its worst case and then the antenna was tuned to heights from 1 meter to 4 meters and the table was turned from 0 degrees to 360 degrees to find the maximum reading.
5. The test-receiver system was set to Peak Detect Function and Specified Bandwidth with Maximum Hold Mode.
6. If the emission level of the EUT in peak mode was 10 dB lower than the limit specified, then testing could be stopped and the peak values of the EUT would be reported. Otherwise the emissions that did not have 10 dB margin would be re-tested one by one using peak, quasi-peak or average method as specified and then reported in a data sheet.

NOTE ;

1. The resolution bandwidth and video bandwidth of test receiver/spectrum analyzer is 120 kHz for Peak detection (PK) or Quasi-peak detection (QP) at frequency below 1 GHz.
2. The resolution bandwidth and video bandwidth of test receiver/spectrum analyzer is 1 MHz for Peak detection and frequency above 1 GHz.
3. The resolution bandwidth of test receiver/spectrum analyzer is 1 MHz and the video bandwidth is 10 Hz for Average detection (AV) at frequency above 1 GHz.

2.3.2. Test Procedures for Conducted Spurious Emissions

1. The transmitter output was connected to the spectrum analyzer.
2. The bandwidth of the fundamental frequency was measured with the spectrum analyzer using RBW = 100 kHz, VBW = 100 kHz.

The results shown in this test report refer only to the sample(s) tested unless otherwise stated. This test report cannot be reproduced, except in full, without prior written permission of the Company.

2.4. Test Results

Ambient temperature : (24 ± 2) °C
 Relative humidity : 47 % R.H.

2.4.1. Spurious Radiated Emission (Worst case configuration_11g mode)

The frequency spectrum from 30 MHz to 1 000 MHz was investigated. Emission levels are not reported much lower than the limits by over 30 dB. All reading values are peak values.

Radiated Emissions			Ant	Correction Factors		Total	FCC Limit	
Frequency (MHz)	Reading (dBμV)	Detect Mode	Pol.	AF (dB/m)	AMP + CL (dB)	Actual (dBμV/m)	Limit (dBμV/m)	Margin (dB)
30.081	39.9	Peak	V	11.08	-27.75	23.2	40.0	16.8
41.842	37.1	Peak	V	12.32	-27.61	21.8	40.0	18.2
126.111	38.2	Peak	H	8.39	-26.86	19.7	43.5	23.8
245.744	37.4	Peak	V	11.60	-25.85	23.2	46.0	22.9
442.371	40.0	Peak	V	16.22	-26.43	29.8	46.0	16.2
491.518	43.8	Peak	V	17.10	-26.50	34.4	46.0	11.6
589.852	36.9	Peak	V	18.93	-26.48	29.4	46.0	16.7
Above 600.000	Not detected	-	-	-	-	-	-	-

Remark:

1. All spurious emission at channels are almost the same below 1 GHz, so that the channel was chosen at representative in final test.
2. Actual = Reading + AF + AMP + CL

The results shown in this test report refer only to the sample(s) tested unless otherwise stated. This test report cannot be reproduced, except in full, without prior written permission of the Company.

2.4.2. Spurious Radiated Emission

The frequency spectrum above 1000 MHz was investigated. Emission levels are not reported much lower than the limits by over 30 dB.

DSSS : 802.11b

Low Channel (2 412 MHz)

Radiated Emissions			Ant	Correction Factors		Total	FCC Limit	
Frequency (MHz)	Reading (dB μ V)	Detect Mode	Pol.	AF (dB/m)	CL (dB)	Actual (dB μ V/m)	Limit (dB μ V/m)	Margin (dB)
*2 390.000	31.24	Peak	H	28.09	4.84	64.17	74.00	9.83
*2 390.000	17.41	Average	H	28.09	4.84	50.34	54.00	3.66

Radiated Emissions			Ant	Correction Factors		Total	FCC Limit	
Frequency (MHz)	Reading (dB μ V)	Detect Mode	Pol.	AF (dB/m)	AMP+CL (dB)	Actual (dB μ V/m)	Limit (dB μ V/m)	Margin (dB)
4 823.930	48.65	Peak	H	32.66	-27.79	53.52	74.00	20.48
4 823.930	44.96	Average	H	32.66	-27.79	49.83	54.00	4.17
Above 4 900.000	Not detected	-	-	-	-	-	-	-

Middle Channel (2 437 MHz)

Radiated Emissions			Ant	Correction Factors		Total	FCC Limit	
Frequency (MHz)	Reading (dB μ V)	Detect Mode	Pol.	AF (dB/m)	AMP+CL (dB)	Actual (dB μ V/m)	Limit (dB μ V/m)	Margin (dB)
4 874.016	50.00	Peak	H	32.87	-27.62	55.25	74.00	18.75
4 874.016	45.62	Average	H	32.87	-27.62	50.87	54.00	3.13
Above 4 900.000	Not detected	-	-	-	-	-	-	-

The results shown in this test report refer only to the sample(s) tested unless otherwise stated. This test report cannot be reproduced, except in full, without prior written permission of the Company.

High Channel (2 462 MHz)

Radiated Emissions			Ant	Correction Factors		Total	FCC Limit	
Frequency (MHz)	Reading (dB μ V)	Detect Mode	Pol.	AF (dB/m)	CL (dB)	Actual (dB μ V/m)	Limit (dB μ V/m)	Margin (dB)
*2 483.500	30.89	Peak	H	28.09	4.78	63.76	74.00	10.24
*2 483.500	17.25	Average	H	28.09	4.78	50.12	54.00	3.88

Radiated Emissions			Ant	Correction Factors		Total	FCC Limit	
Frequency (MHz)	Reading (dB μ V)	Detect Mode	Pol.	AF (dB/m)	AMP+CL (dB)	Actual (dB μ V/m)	Limit (dB μ V/m)	Margin (dB)
4 924.007	51.21	Peak	H	33.10	-27.38	56.93	74.00	17.07
4 924.007	46.12	Average	H	33.10	-27.38	51.84	54.00	2.16
Above 5 000.000	Not detected	-	-	-	-	-	-	-

The results shown in this test report refer only to the sample(s) tested unless otherwise stated. This test report cannot be reproduced, except in full, without prior written permission of the Company.

OFDM : 802.11g

Low Channel (2 412 MHz)

Radiated Emissions			Ant	Correction Factors		Total	FCC Limit	
Frequency (MHz)	Reading (dB μ V)	Detect Mode	Pol.	AF (dB/m)	CL (dB)	Actual (dB μ V/m)	Limit (dB μ V/m)	Margin (dB)
*2 390.000	30.97	Peak	H	28.09	4.84	63.90	74.00	10.10
*2 390.000	17.73	Average	H	28.09	4.84	50.66	54.00	3.34

Radiated Emissions			Ant	Correction Factors		Total	FCC Limit	
Frequency (MHz)	Reading (dB μ V)	Detect Mode	Pol.	AF (dB/m)	AMP+CL (dB)	Actual (dB μ V/m)	Limit (dB μ V/m)	Margin (dB)
4 823.940	46.05	Peak	H	32.66	-27.79	50.92	74.00	23.08
Above 4 900.000	Not detected	-	-	-	-	-	-	-

Middle Channel (2 437 MHz)

Radiated Emissions			Ant	Correction Factors		Total	FCC Limit	
Frequency (MHz)	Reading (dB μ V)	Detect Mode	Pol.	AF (dB/m)	AMP+CL (dB)	Actual (dB μ V/m)	Limit (dB μ V/m)	Margin (dB)
4 874.242	45.80	Peak	H	32.87	-27.62	51.05	74.00	22.95
Above 4 900.000	Not detected	-	-	-	-	-	-	-

The results shown in this test report refer only to the sample(s) tested unless otherwise stated. This test report cannot be reproduced, except in full, without prior written permission of the Company.

High Channel (2 462 MHz)

Radiated Emissions			Ant	Correction Factors		Total	FCC Limit	
Frequency (MHz)	Reading (dB μ V)	Detect Mode	Pol.	AF (dB/m)	CL (dB)	Actual (dB μ V/m)	Limit (dB μ V/m)	Margin (dB)
*2 483.500	31.27	Peak	H	28.09	4.78	64.14	74.00	9.86
*2 483.500	18.04	Average	H	28.09	4.78	50.91	54.00	3.09

Radiated Emissions			Ant	Correction Factors		Total	FCC Limit	
Frequency (MHz)	Reading (dB μ V)	Detect Mode	Pol.	AF (dB/m)	AMP+CL (dB)	Actual (dB μ V/m)	Limit (dB μ V/m)	Margin (dB)
4 923.789	45.88	Peak	H	33.09	-27.38	51.59	74.00	22.41
Above 5 000.000	Not detected	-	-	-	-	-	-	-

Remarks ;

1. “*” means the restricted band.
2. Measuring frequencies from 1 GHz to the 10th harmonic of highest fundamental Frequency.
3. Radiated emissions measured in frequency above 1 000 MHz were made with an instrument using peak/average detector mode.
4. Average test would be performed if the peak result were greater than the average limit.
5. Actual = Reading + AF + AMP + CL

The results shown in this test report refer only to the sample(s) tested unless otherwise stated. This test report cannot be reproduced, except in full, without prior written permission of the Company.

2.4.3. Spurious RF Conducted Emissions: Plot of Spurious RF Conducted Emission

DSSS : 802.11b

Low Channel

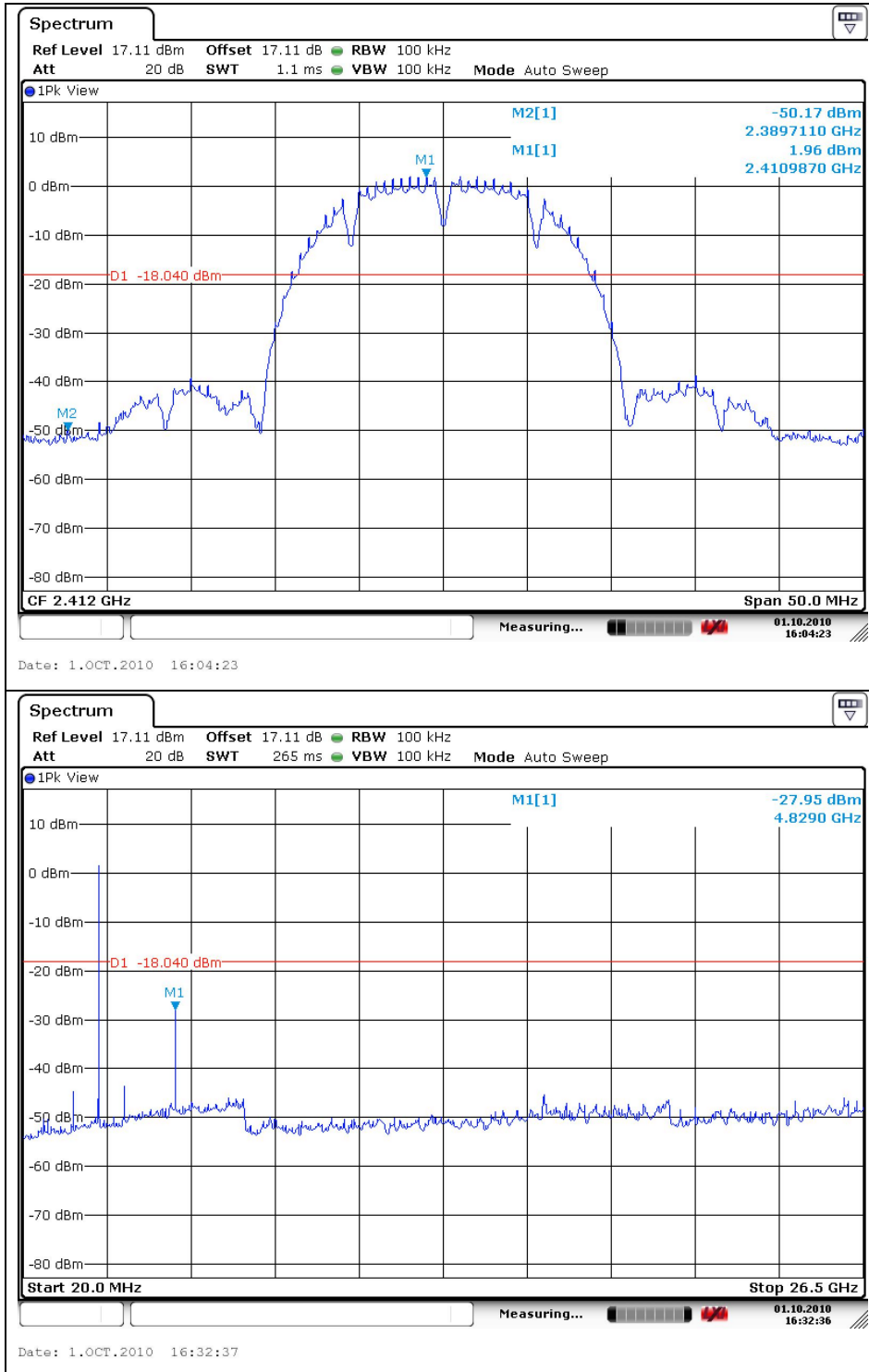

The results shown in this test report refer only to the sample(s) tested unless otherwise stated. This test report cannot be reproduced, except in full, without prior written permission of the Company.

Middle Channel

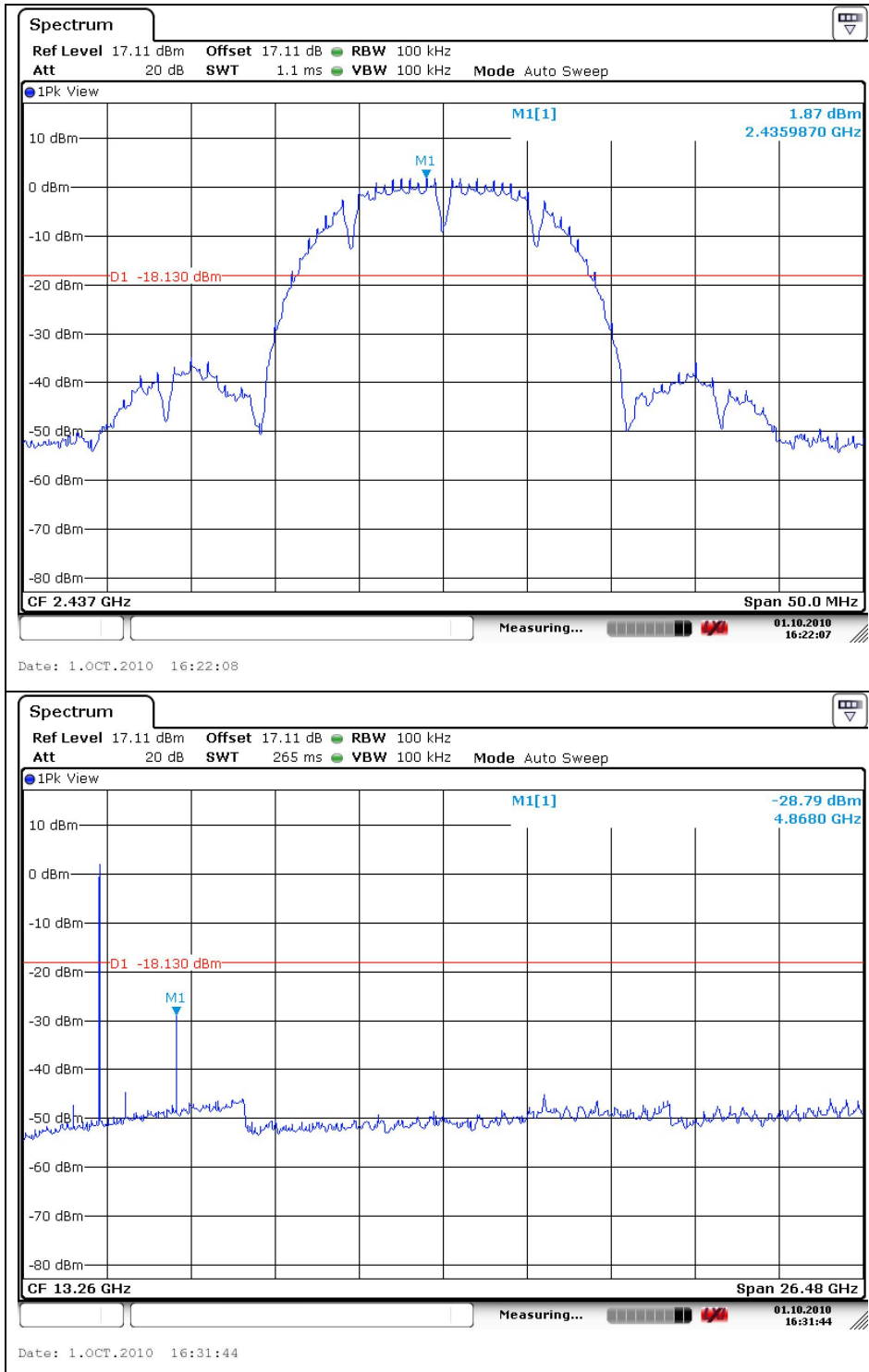

The results shown in this test report refer only to the sample(s) tested unless otherwise stated. This test report cannot be reproduced, except in full, without prior written permission of the Company.

High Channel

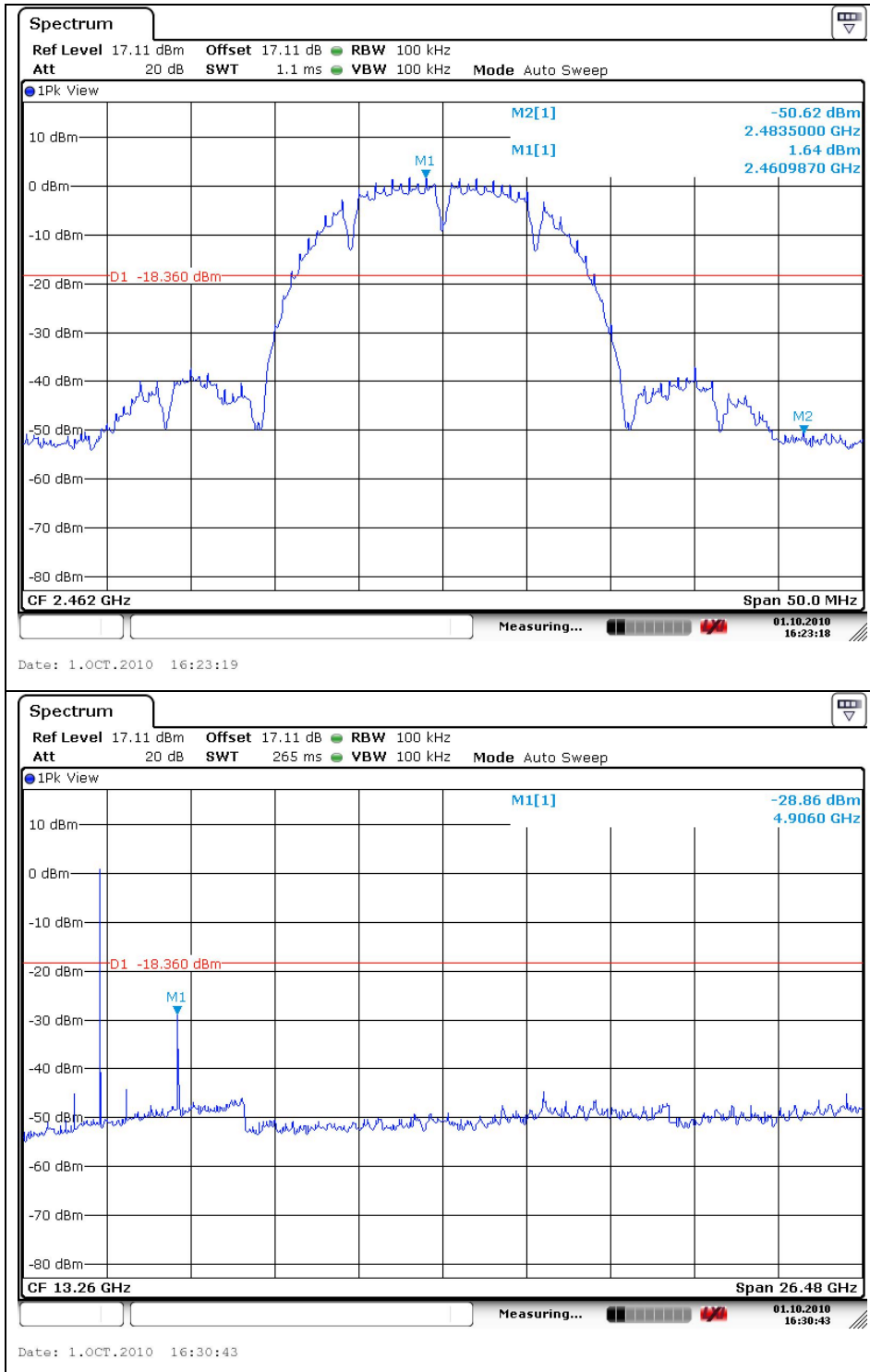

The results shown in this test report refer only to the sample(s) tested unless otherwise stated. This test report cannot be reproduced, except in full, without prior written permission of the Company.

OFDM : 802.11g
Low Channel

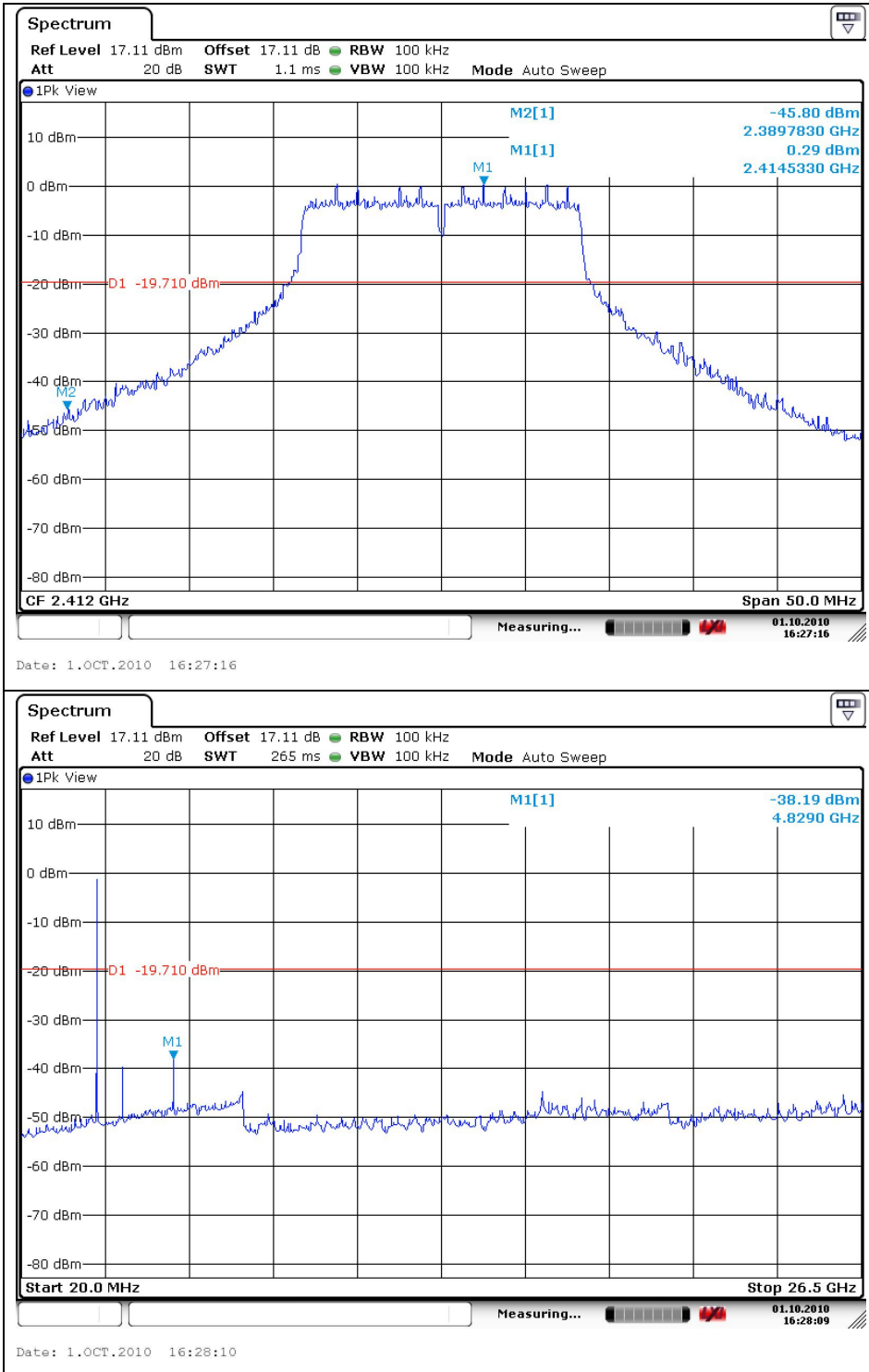

The results shown in this test report refer only to the sample(s) tested unless otherwise stated. This test report cannot be reproduced, except in full, without prior written permission of the Company.

Middle Channel

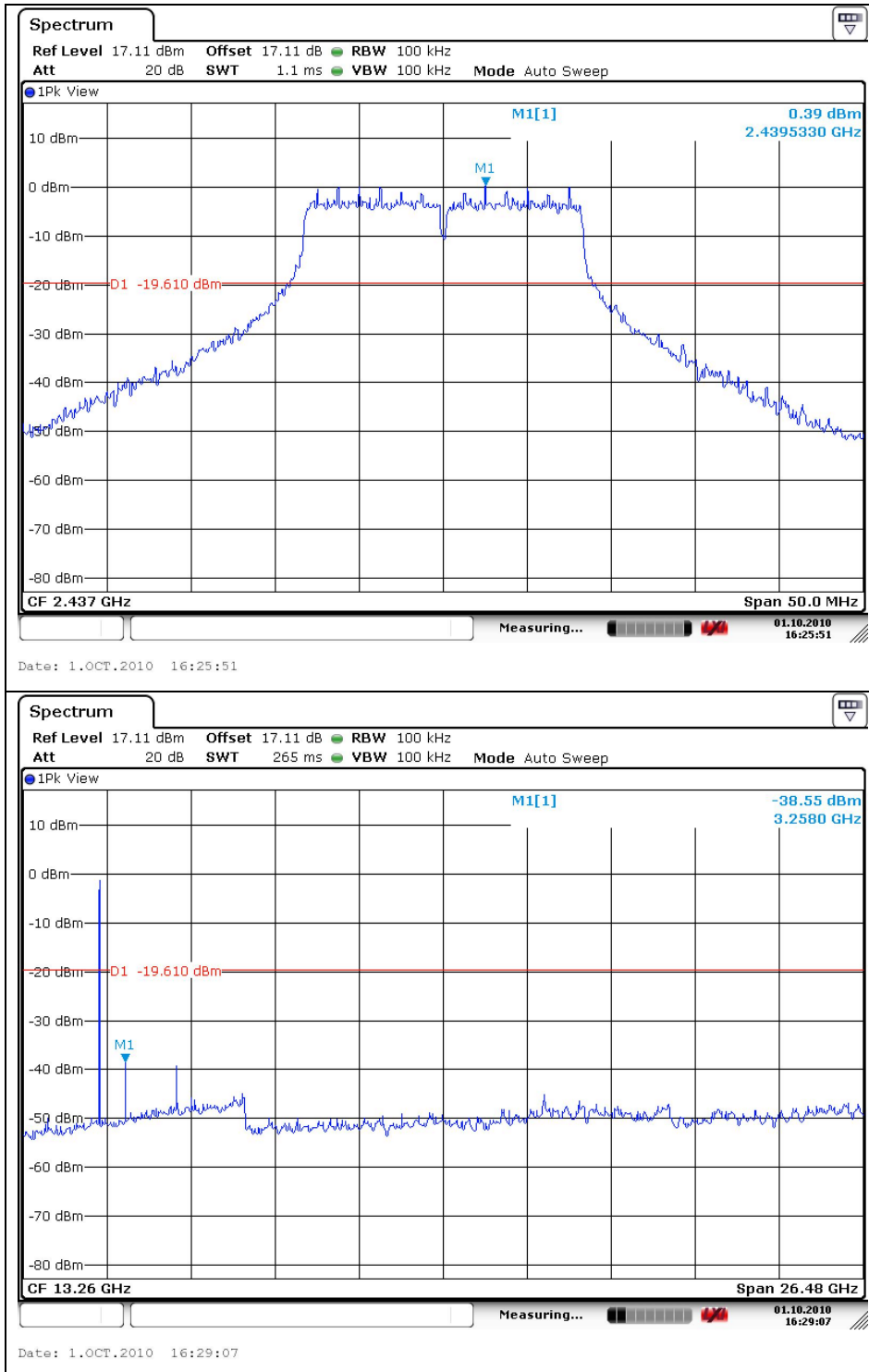

The results shown in this test report refer only to the sample(s) tested unless otherwise stated. This test report cannot be reproduced, except in full, without prior written permission of the Company.

High Channel

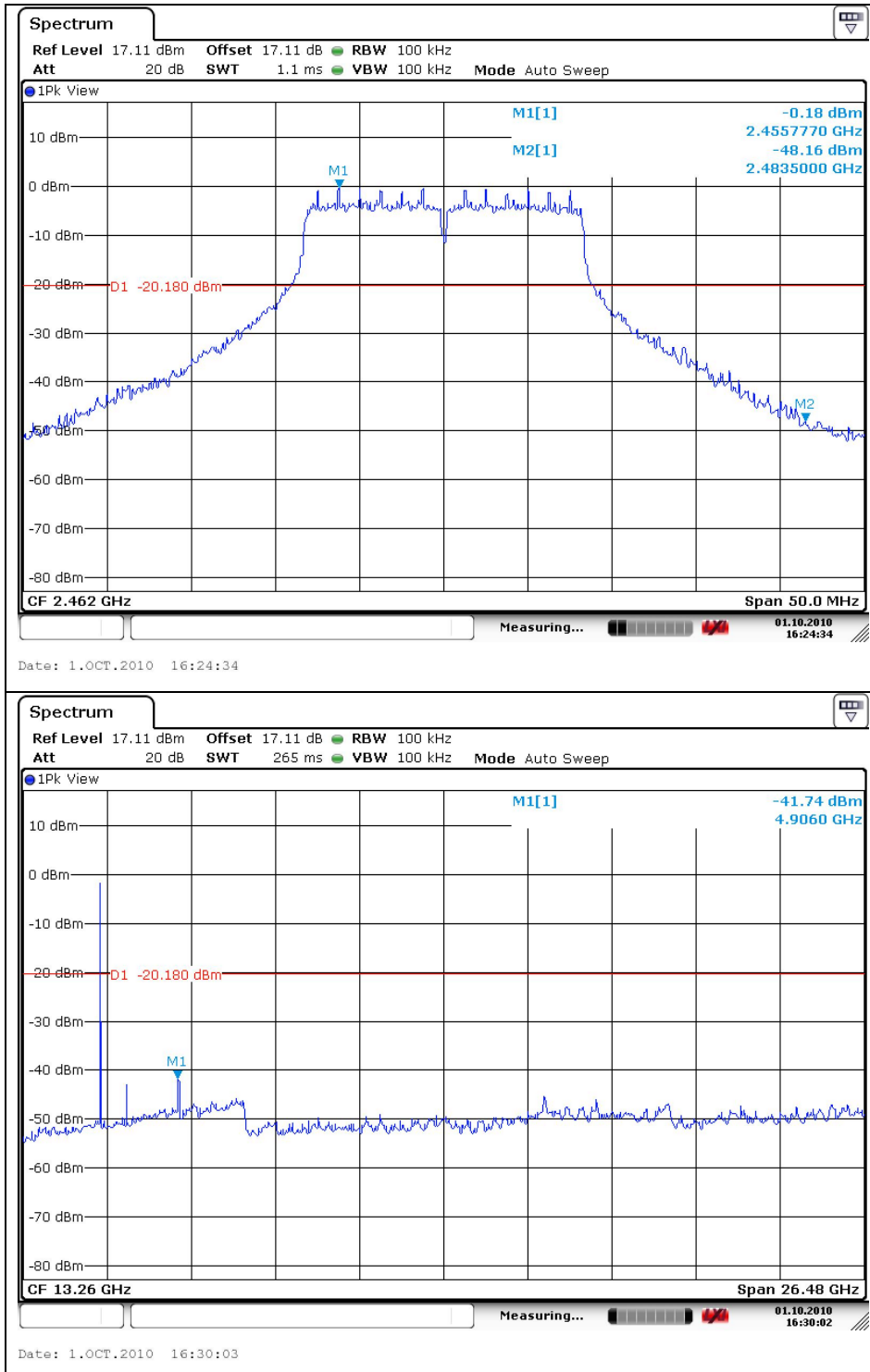

The results shown in this test report refer only to the sample(s) tested unless otherwise stated. This test report cannot be reproduced, except in full, without prior written permission of the Company.

3. 6 dB Bandwidth Measurement

3.1. Test Setup

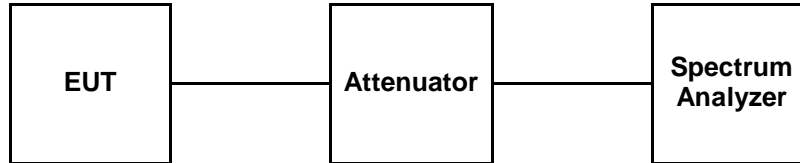

3.2. Limit

According to §15.247(a)(2), systems using digital modulation techniques may operate in the 902 ~928 MHz, 2 400 ~ 2 483.5 MHz, and 5 725 ~ 5 825 MHz bands. The minimum of 6 dB Bandwidth shall be at least 500 kHz

3.3. Test Procedure

1. The 6 dB band width was measured with a spectrum analyzer connected to RF antenna connector(conducted measurement) while EUT was operating in transmit mode at the appropriate center frequency. The analyzer center frequency was set to the EUT carrier frequency, using the analyzer. Display Line and Marker Delta functions, the 6 dB band width of the emission was determined.
2. The bandwidth of the fundamental frequency was measured with the spectrum analyzer using RBW = 100 kHz, VBW = 100 kHz, Span = 50 MHz.

The results shown in this test report refer only to the sample(s) tested unless otherwise stated. This test report cannot be reproduced, except in full, without prior written permission of the Company.

3.4. Test Results

Ambient temperature : (24 ± 2) °C
 Relative humidity : 47 % R.H.

Operation Mode	Channel	Channel Frequency (MHz)	6 dB Bandwidth (MHz)	Minimum Limit (MHz)
DSSS (802.11b)	Low	2 412	12.16	0.5
	Middle	2 437	12.16	
	High	2 462	12.12	
OFDM (802.11g)	Low	2 412	16.35	
	Middle	2 437	16.35	
	High	2 462	16.35	

The results shown in this test report refer only to the sample(s) tested unless otherwise stated. This test report cannot be reproduced, except in full, without prior written permission of the Company.

DSSS : 802.11b

Low Channel

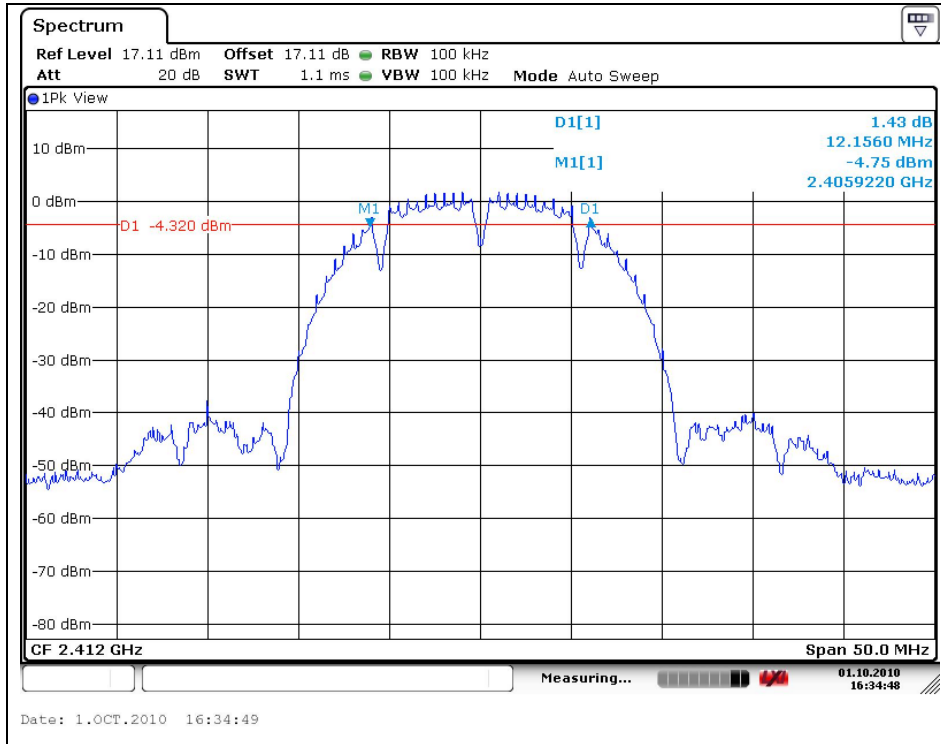

Middle Channel

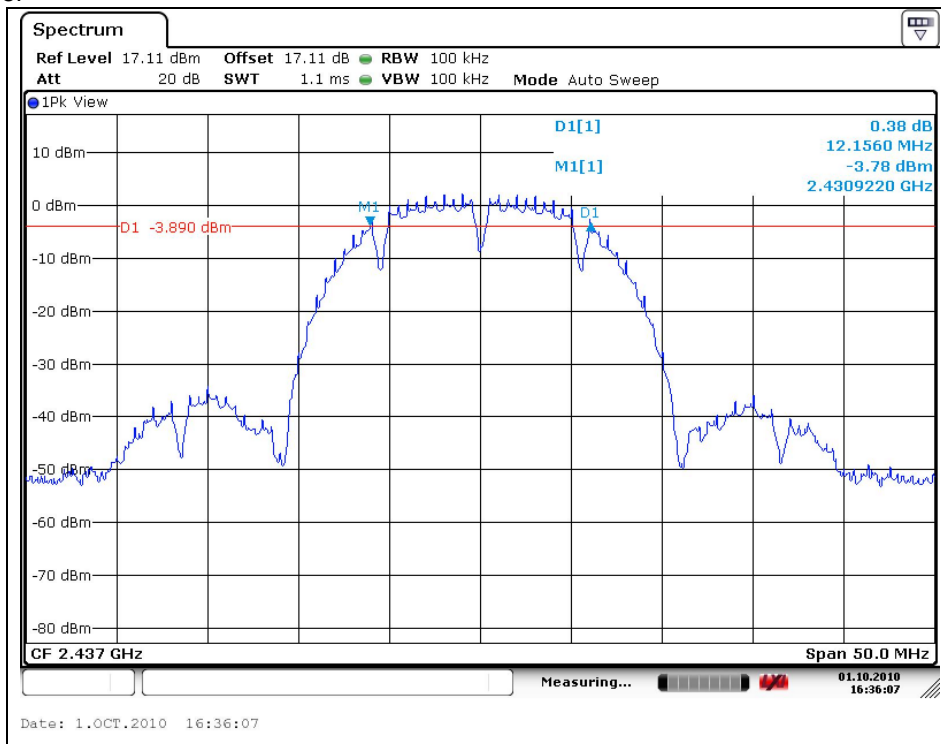

The results shown in this test report refer only to the sample(s) tested unless otherwise stated. This test report cannot be reproduced, except in full, without prior written permission of the Company.

High Channel

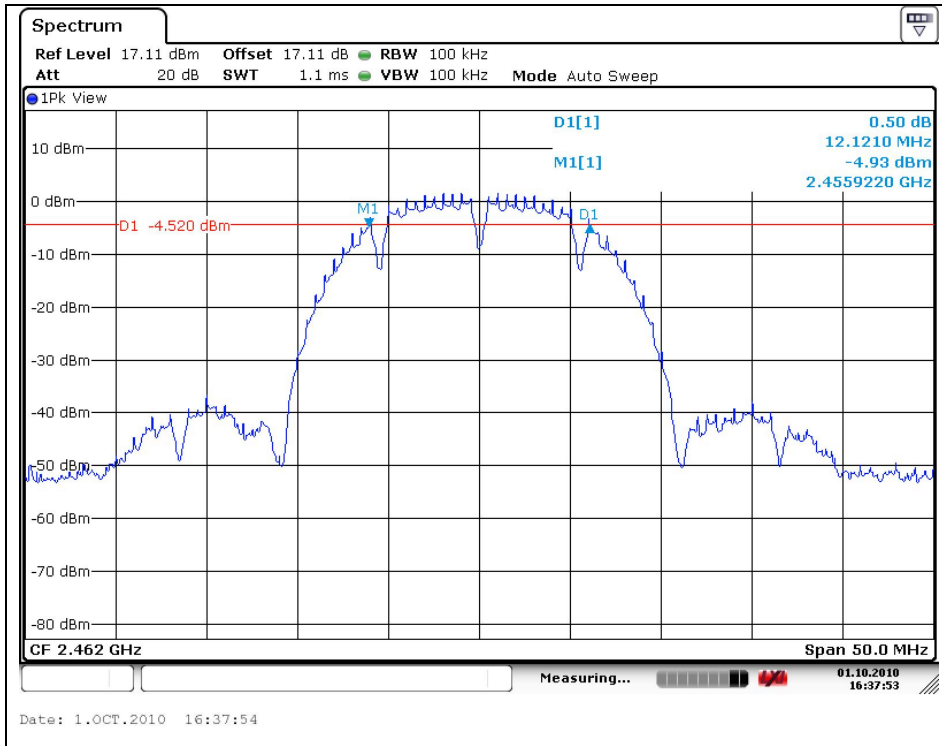

OFDM : 802.11g

Low Channel

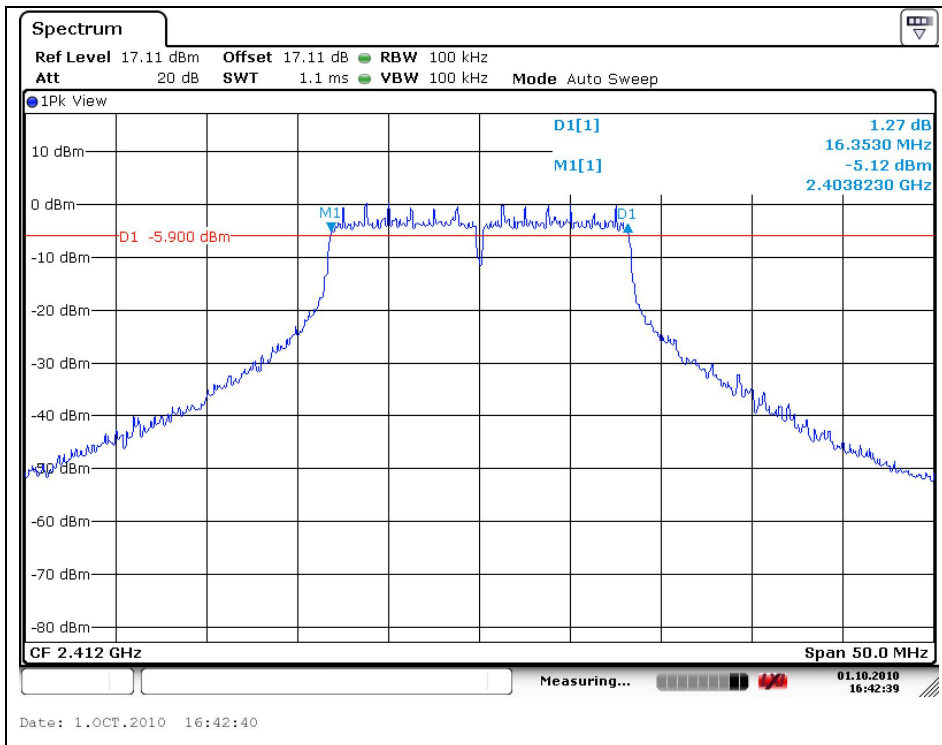

The results shown in this test report refer only to the sample(s) tested unless otherwise stated. This test report cannot be reproduced, except in full, without prior written permission of the Company.

Middle Channel

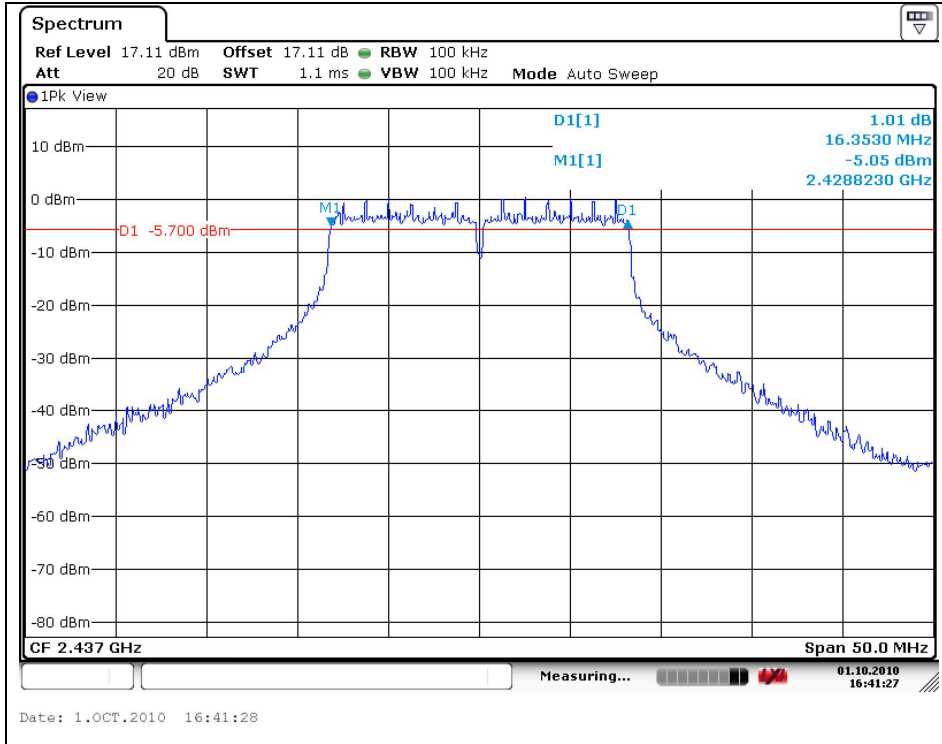

High Channel

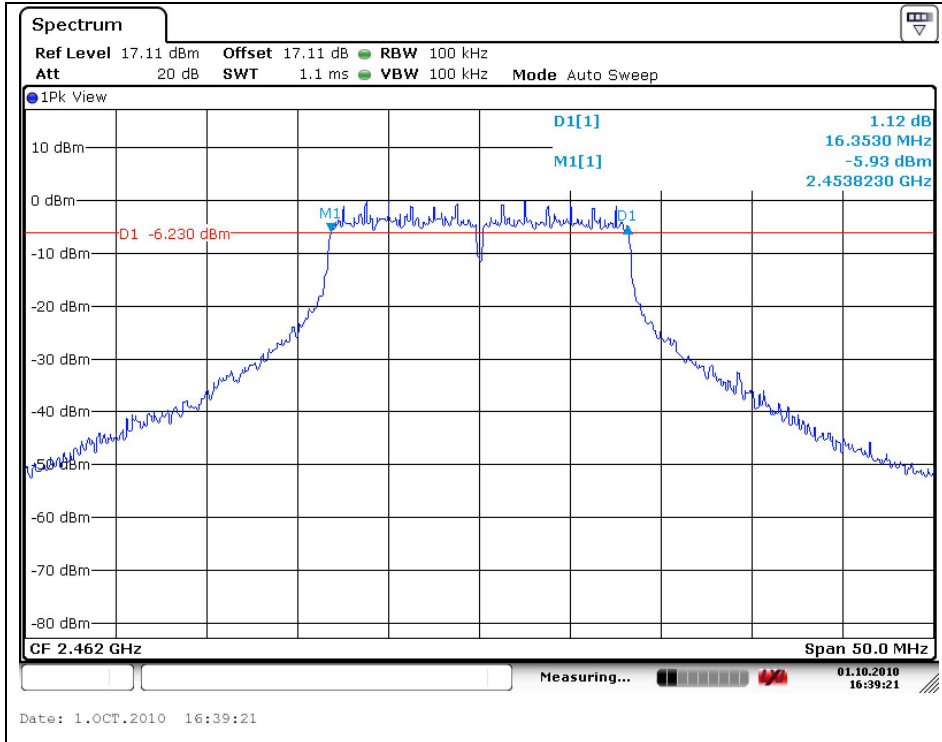

The results shown in this test report refer only to the sample(s) tested unless otherwise stated. This test report cannot be reproduced, except in full, without prior written permission of the Company.

4. Maximum Peak Output Power Measurement

4.1. Test Setup

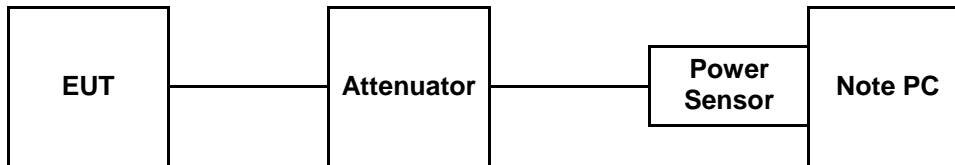

4.2. Limit

According to §15.247(b)(3), for systems using digital modulation in the 902 ~ 928 MHz, 2 400 ~2 483.5 MHz, and 5 725 ~ 5 850 MHz band: 1 Watt. As an alternative to a peak power measurement, compliance with the one watt limit can be based on a measurement of the maximum conducted output power. Maximum Conducted output Power is defined as the total transmit power delivered to all antennas and antenna elements averaged across all symbols in the signaling alphabet when the transmitter is operating at its maximum power control level. Power must be summed across all antenna elements. The average must not include any intervals during which the transmitter is off or is transmitting at a reduced power level. If multiple modes of operation are possible (e.g., alternative modulation methods), the maximum conducted output power is the highest total transmit power occurring in any mode.

According to §15.247(b)(4), the conducted output power limit specified in paragraph(b) of this section is based on the use of antenna with directional gains that do not exceed 6 dBi. Except as shown in paragraph(c) of this section, if transmitting antenna of directional gain greater than 6 dBi are used, the conducted output power from the intentional radiator shall be reduced below the stated values in paragraph (b)(1), (b)(2), and (b)(3) of this section , as appropriate, by the amount in dB that the directional gain of the antenna exceeds 6dBi.

4.3. Test Procedure

1. Place the EUT on the table and set it in the transmitting mode.
2. Remove the antenna from the EUT and then connect a low loss RF cable from the antenna port to the Power sensor.

The results shown in this test report refer only to the sample(s) tested unless otherwise stated. This test report cannot be reproduced, except in full, without prior written permission of the Company.

4.4. Test Results

Ambient temperature : (24 ± 2) °C
 Relative humidity : 47 % R.H.

Operation Mode	Channel	Channel Frequency (MHz)	Peak Power Output (dB m)	Peak Power Limit (dB m)
DSSS (802.11b)	Low	2 412	17.46	30
	Middle	2 437	17.31	30
	High	2 462	16.57	30
OFDM (802.11g)	Low	2 412	23.59	30
	Middle	2 437	23.33	30
	High	2 462	23.15	30

The results shown in this test report refer only to the sample(s) tested unless otherwise stated. This test report cannot be reproduced, except in full, without prior written permission of the Company.

5. POWER SPECTRAL DENSITY MEASUREMENT

5.1. Test Setup

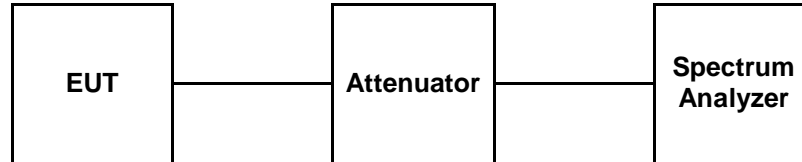

5.2. Limit

§15.247(e) For digitally modulated system, the power spectral density conducted from the intentional radiator to the antenna shall not be greater than 8 dB m in any 3 kHz band any time interval of continuous transmission. This power spectral density shall be determined in accordance with the provisions of paragraph (b) of this section. The same method of determining the conducted output power shall be used to determine the power spectral density.

5.3. Test Procedure

1. Check the calibration of the measuring instrument using either an internal calibrator or a known signal from an external generator.
2. Position the EUT as shown in test setup without connection to measurement instrument. Turn on the EUT and connect it to measurement instrument. Then set it to any one convenient frequency within its operating range.
3. By using the Max Hold function record the separation of adjacent channels.
4. Repeat above procedures until all frequencies measured were complete.
5. The bandwidth of the fundamental frequency was measured with the spectrum analyzer using ;
RBW = 3 kHz, VBW = 10 kHz, Span = 300 kHz and Sweep = 100 s.

The results shown in this test report refer only to the sample(s) tested unless otherwise stated. This test report cannot be reproduced, except in full, without prior written permission of the Company.

5.4. Test Results

Ambient temperature : (24 ± 2) °C
 Relative humidity : 47 % R.H.

Operation Mode	Frequency	Final RF Power Level in 3 kHz BW (dB m)	Maximum Limit (dB m)
DSSS (802.11b)	2 412 MHz	-13.04	8
	2 437 MHz	-13.49	8
	2 462 MHz	-13.39	8
OFDM (802.11g)	2 412 MHz	-13.29	8
	2 437 MHz	-13.32	8
	2 462 MHz	-13.65	8

The results shown in this test report refer only to the sample(s) tested unless otherwise stated. This test report cannot be reproduced, except in full, without prior written permission of the Company.

DSSS : 802.11b

Low Channel

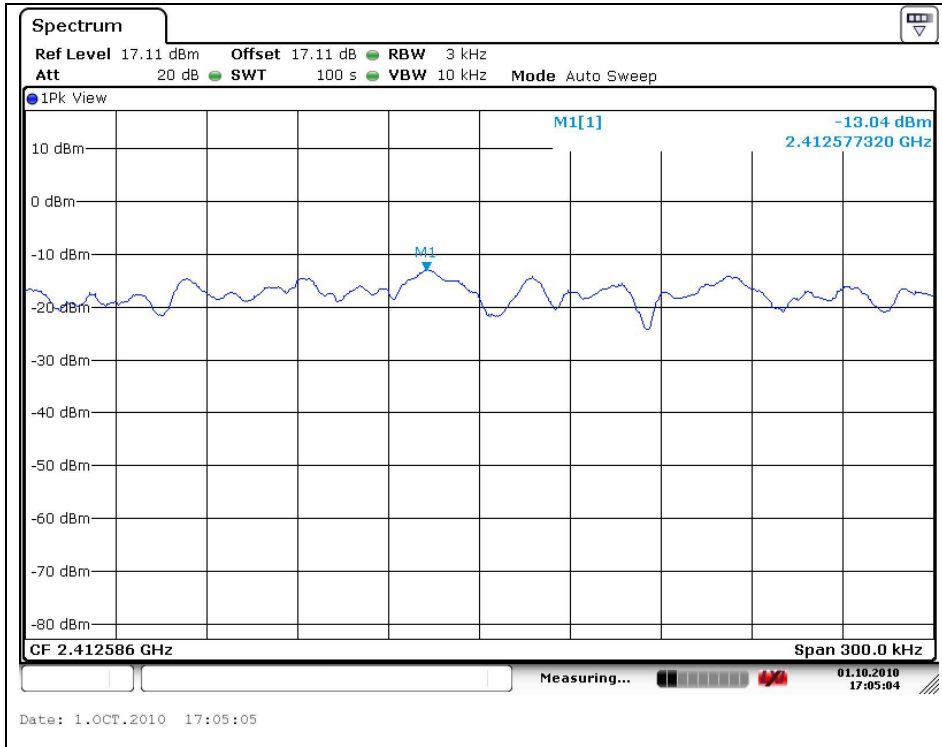

Middle Channel

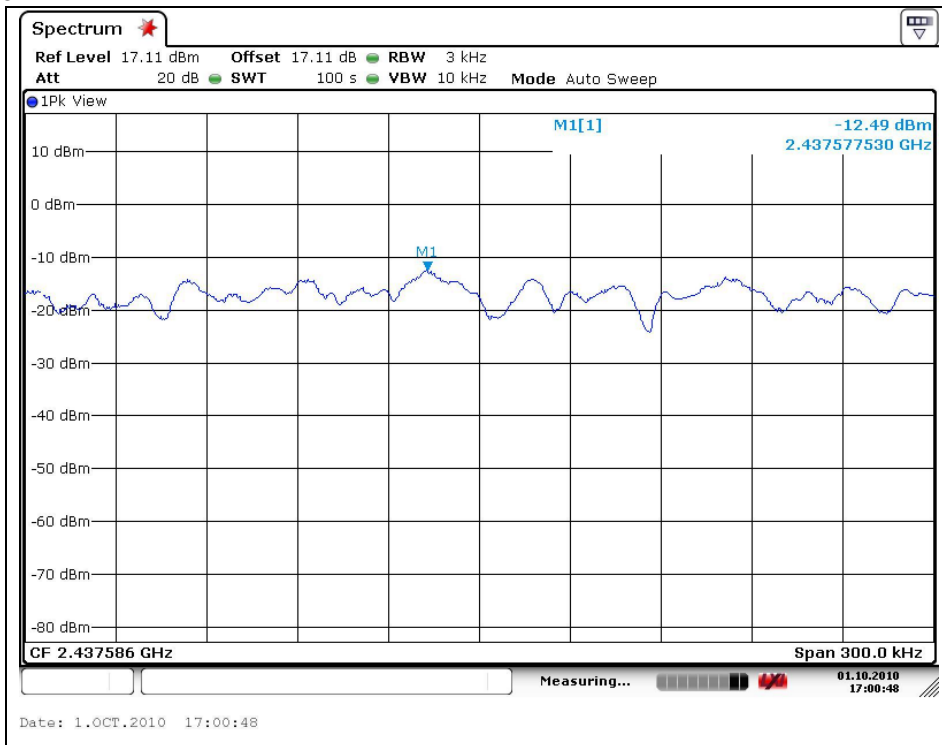

The results shown in this test report refer only to the sample(s) tested unless otherwise stated. This test report cannot be reproduced, except in full, without prior written permission of the Company.

High Channel

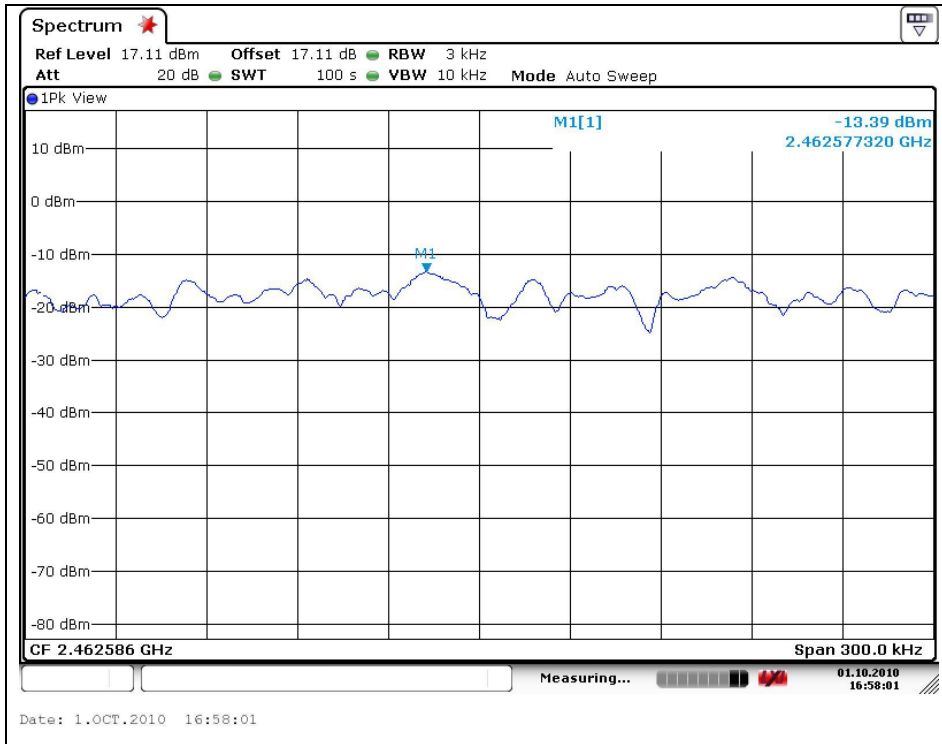

OFDM : 802.11g

Low Channel

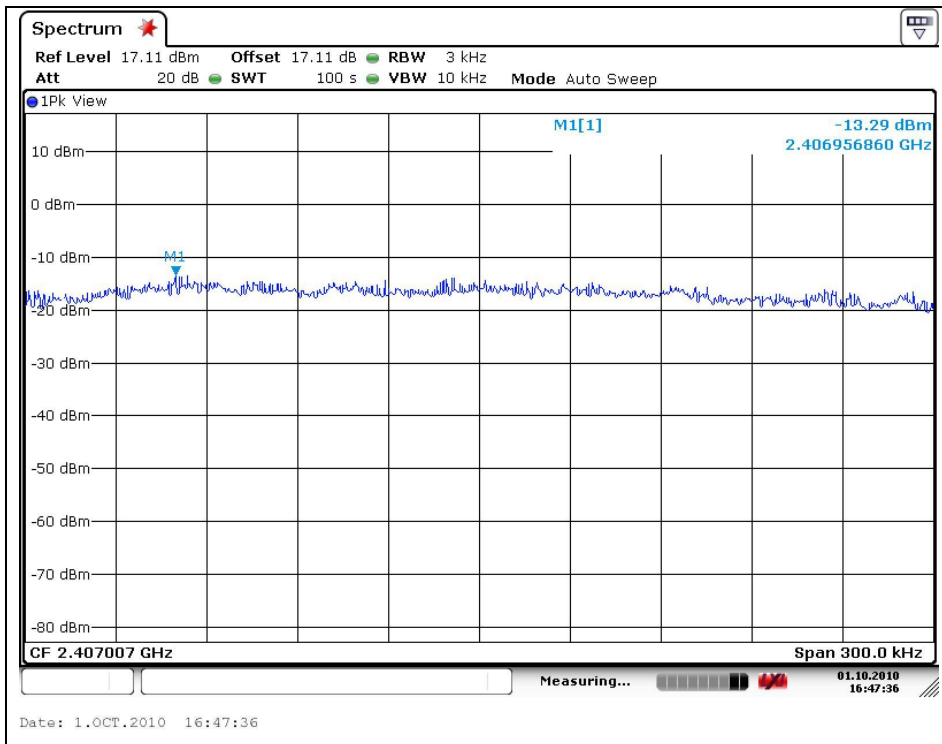

The results shown in this test report refer only to the sample(s) tested unless otherwise stated. This test report cannot be reproduced, except in full, without prior written permission of the Company.

Middle Channel

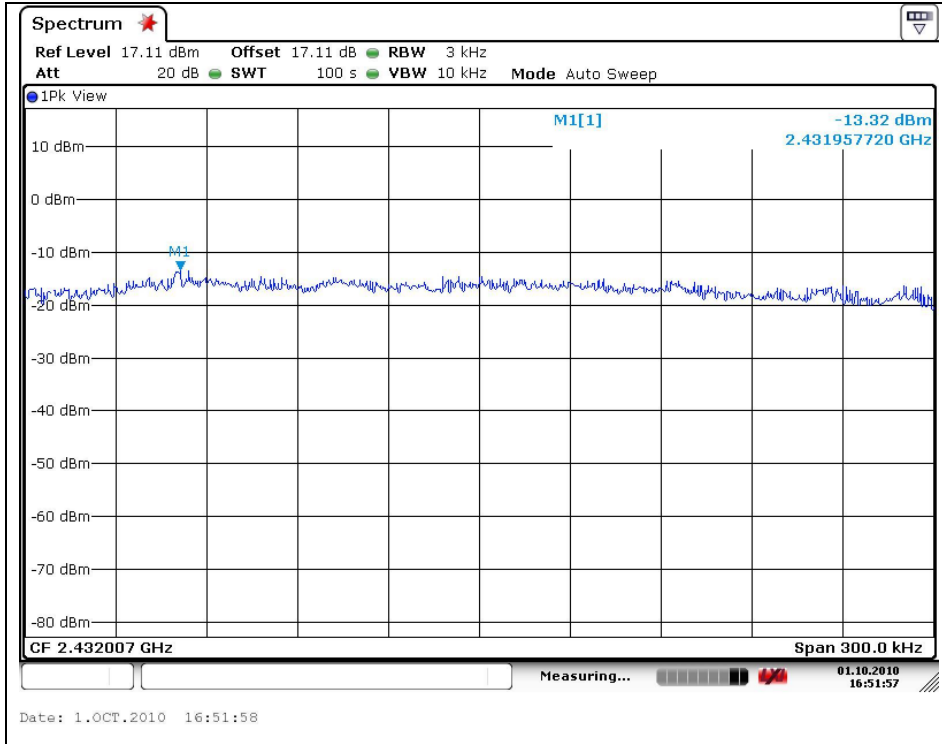

High Channel

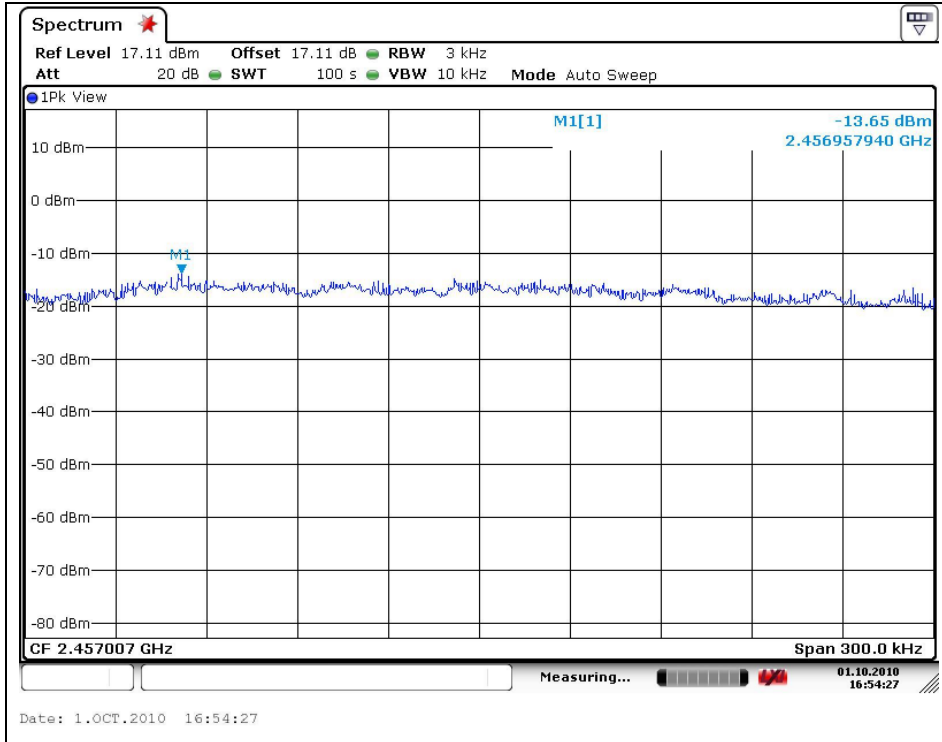

The results shown in this test report refer only to the sample(s) tested unless otherwise stated. This test report cannot be reproduced, except in full, without prior written permission of the Company.

6. Transmitter AC Power Line Conducted Emission

6.1. Test Setup

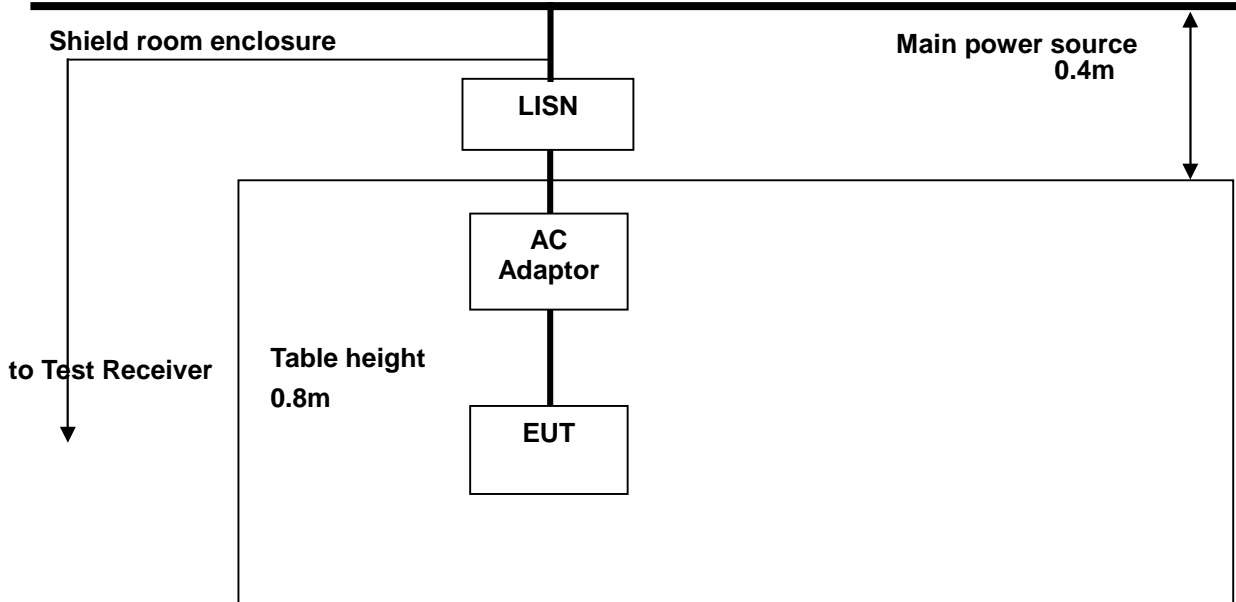

6.2. Limit

According to §15.207(a) for an intentional radiator that is designed to be connected to the public utility (AC) power line, the radio frequency voltage that is conducted back onto the AC power line on any frequency or frequencies, within the band 150 kHz to 30 MHz, shall not exceed the limits in the following table, as measured using a 50 uH/50 ohm line impedance stabilization network(LISN).

Compliance with the provision of this paragraph shall on the measurement of the radio frequency voltage between each power line and ground at the power terminal. The lower applies at the boundary between the frequency ranges.

Frequency of Emission (MHz)	Conducted limit (dB μ V)	
	Quasi-peak	Average
0.15 – 0.50	66 - 56*	56 - 46*
0.50 – 5.00	56	46
5.00 – 30.0	60	50

* Decreases with the logarithm of the frequency.

The results shown in this test report refer only to the sample(s) tested unless otherwise stated. This test report cannot be reproduced, except in full, without prior written permission of the Company.

6.3. Test Procedures

Radiated emissions from the EUT were measured according to the dictates of ANSI C63.4:2003

1. The test procedure is performed in a 6.5m × 3.6m × 3.6m (L × W × H) shielded room. The EUT along with its peripherals were placed on a 1.0 m(W) × 1.5 m(L) and 0.8 m in height wooden table and the EUT was adjusted to maintain a 0.4 meter space from a vertical reference plane.
2. The EUT was connected to power mains through a line impedance stabilization network (LISN) which provides 50 ohm coupling impedance for measuring instrument and the chassis ground was bounded to the horizontal ground plane of shielded room.
3. All peripherals were connected to the second LISN and the chassis ground also bounded to the horizontal ground plane of shielded room.
4. The excess power cable between the EUT and the LISN was bundled. The power cables of peripherals were unbundled. All connecting cables of EUT and peripherals were moved to find the maximum emission.

The results shown in this test report refer only to the sample(s) tested unless otherwise stated. This test report cannot be reproduced, except in full, without prior written permission of the Company.

6.4. Test Results (Worst case configuration_ 11g mode)

The following table shows the highest levels of conducted emissions on both phase of Hot and Neutral line.

Ambient temperature : (24 ± 2) °C
 Relative humidity : 47 % R.H.

Frequency range : 0.15 MHz – 30 MHz

Measured Bandwidth : 9 kHz

FREQ. (MHz)	LEVEL(dB μ V)		LINE	LIMIT(dB μ V)		MARGIN(dB)	
	Q-Peak	Average		Q-Peak	Average	Q-Peak	Average
0.15	54.0	34.5	H	66.0	56.0	12.0	21.5
0.20	45.8	28.3	H	63.8	53.8	18.0	25.5
3.20	28.2	17.1	H	56.0	46.0	27.8	28.9
8.11	34.9	27.4	H	60.0	50.0	25.1	22.6
14.25	21.2	13.1	H	60.0	50.0	38.8	36.9
25.06	35.3	32.3	H	60.0	50.0	24.7	17.7
0.15	52.8	34.1	N	66.0	56.0	13.2	21.9
0.20	44.4	27.4	N	63.8	53.8	19.4	26.4
2.97	34.1	23.1	N	56.0	46.0	21.9	22.9
8.17	35.2	26.2	N	60.0	50.0	24.8	23.8
13.08	27.1	19.8	N	60.0	50.0	32.9	30.2
21.64	28.8	23.2	N	60.0	50.0	31.2	26.8

Note ;

Line (H) : Hot

Line (N) : Neutral

The results shown in this test report refer only to the sample(s) tested unless otherwise stated. This test report cannot be reproduced, except in full, without prior written permission of the Company.

Plot of Conducted Power line

Test mode : (Hot)

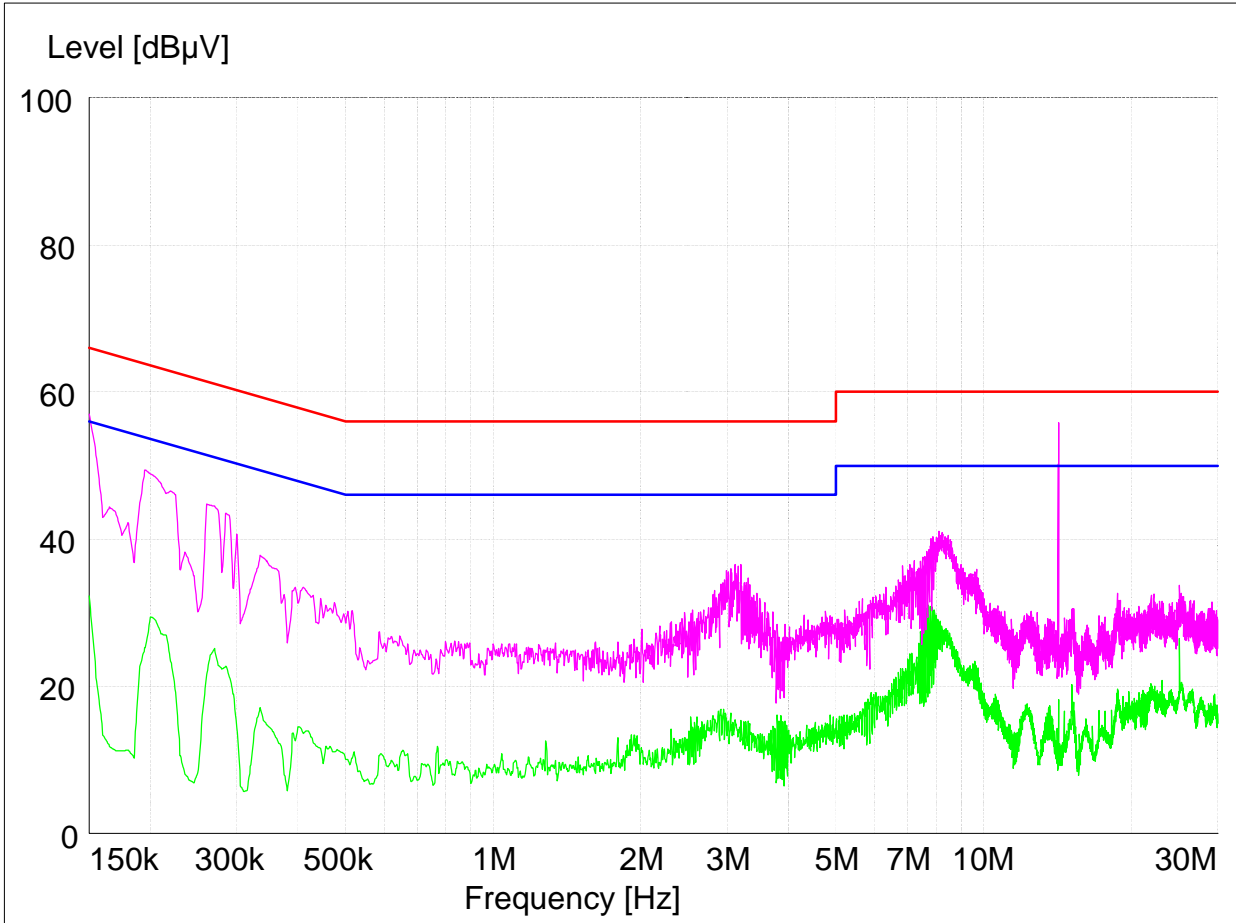

The results shown in this test report refer only to the sample(s) tested unless otherwise stated. This test report cannot be reproduced, except in full, without prior written permission of the Company.

Test mode : (Neutral)

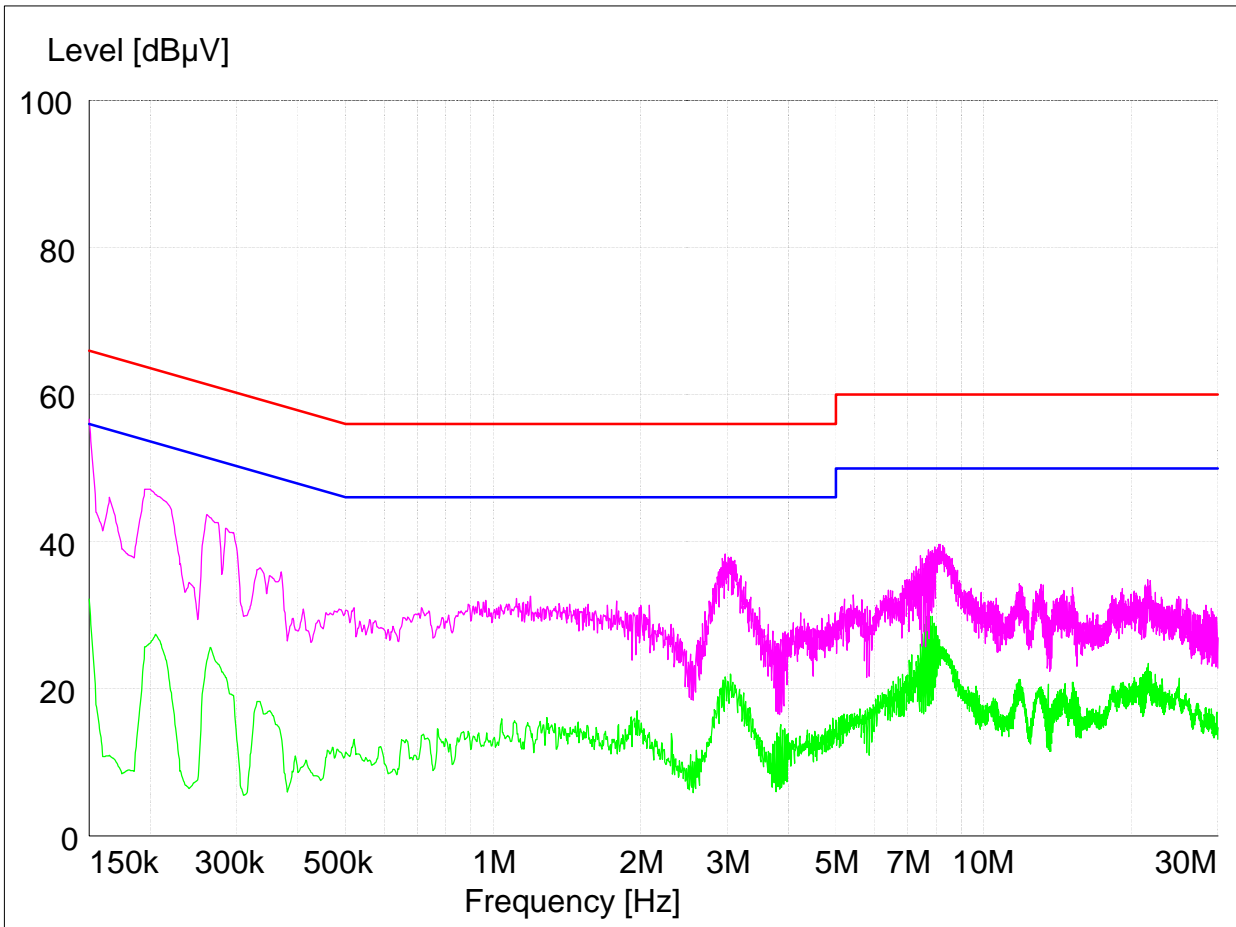

The results shown in this test report refer only to the sample(s) tested unless otherwise stated. This test report cannot be reproduced, except in full, without prior written permission of the Company.

7. Antenna Requirement

7.1. Standard Applicable

For intentional device, according to FCC 47 CFR Section §15.203, an intentional radiator shall be designed to ensure that no antenna other than that furnished by the responsible party shall be used with the device. And according to FCC 47 CFR Section §15.247 (b) if transmitting antennas of directional gain greater than 6 dB i are used, the power shall be reduced by the amount in dB that the gain of the antenna exceeds 6 dB i.

7.2. Antenna Connected Construction

Antenna used in this product is Integral type (Chip Antenna) gain of 1.81 dB i.

The results shown in this test report refer only to the sample(s) tested unless otherwise stated. This test report cannot be reproduced, except in full, without prior written permission of the Company.