

RF TEST REPORT

Test item : PDA
Model No. : MT3XX
Order No. : DEMC1302-00791
Date of receipt : 2013-02-22
Test duration : 2013-03-11 ~ 2013-03-22
Date of issue : 2013-04-10
Use of report : Original Grant

Applicant : Bluebird Soft Inc.
SEI Tower 13,14, 467-14, Dogok-dong, Gangnam-gu, Seoul, Korea

Test laboratory : Digital EMC Co., Ltd.
683-3, Yubang-Dong, Cheoin-Gu, Yongin-Si, Kyunggi-Do, 449-080, Korea

Test specification : §22(H), §24(E)
Test environment : See appended test report
Test result : Pass Fail

The test results presented in this test report are limited only to the sample supplied by applicant and the use of this test report is inhibited other than its purpose. This test report shall not be reproduced except in full, without the written approval of DIGITAL EMC CO., LTD.

Tested by:



Engineer
JaeJin Lee

Witnessed by:

N/A

Reviewed by:

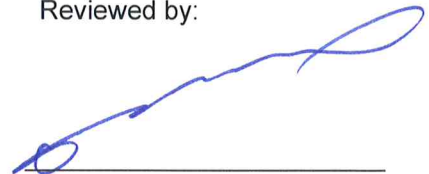

Deputy General Manager
WonJung Lee

Test Report Version

Test Report No.	Date	Description
DRTFCC1304-0341	Apr. 10, 2013	Initial issue

Table of Contents

1. GENERAL INFORMATION	4
2. INTRODUCTION	5
2.1. EUT DESCRIPTION	5
2.2. MEASURING INSTRUMENT CALIBRATION.....	5
2.3. TEST FACILITY	5
3. DESCRIPTION OF TESTS	6
3.1 ERP & EIRP	6
3.2 PEAK TO AVERAGE RATIO	7
3.3 OCCUPIED BANDWIDTH.....	8
3.4 SPURIOUS AND HARMONIC EMISSIONS AT ANTENNA TERMINAL.....	9
3.5 RADIATED SPURIOUS EMISSIONS	10
3.6 FREQUENCY STABILITY / VARIATION OF AMBIENT TEMPERATURE	11
4. LIST OF TEST EQUIPMENT	12
5. SUMMARY OF TEST RESULTS	13
6. SAMPLE CALCULATION	14
7. TEST DATA	15
7.1 CONDUCTED OUTPUT POWER.....	15
7.2 EFFECTIVE RADIATED POWER.....	17
7.3 EQUIVALENT ISOTROPIC RADIATED POWER	18
7.4 RADIATED SPURIOUS EMISSIONS	19
7.4.1 RADIATED SPURIOUS EMISSIONS (GPRS850)	19
7.4.2 RADIATED SPURIOUS EMISSIONS(WCDMA850).....	20
7.4.3 RADIATED SPURIOUS EMISSIONS(HSUPA850)	21
7.4.4 RADIATED SPURIOUS EMISSIONS (GPRS1900)	22
7.4.5 RADIATED SPURIOUS EMISSIONS(WCDMA1900).....	23
7.4.6 RADIATED SPURIOUS EMISSIONS(HSUPA1900)	24

1. GENERAL INFORMATION

Applicant Name: Bluebird Soft Inc.

Address: SEI Tower 13,14, 467-14, Dogok-dong, Gangnam-gu, Seoul, Korea

- FCC ID** : SS4MT3XX
- FCC Classification** : Licensed Portable Transmitter(PCB)
- EUT Type** : PDA
- Model Name** : MT3XX
- Add Model Name** : N/A
- Supplying power** : Standard Battery
 - Type: Li-Ion Battery
 - Rating: DC 3.7 V& 1500mah & 11.1Wh
- Antenna Information** : Internal Antenna
 - Type: Built-In type
- Tx Frequency** :
 - GPRS850: 824.2 ~ 848.8 MHz
 - GPRS1900: 1850.2 ~ 1909.8 MHz
 - EDGE850: 824.2 ~ 848.8 MHz
 - EDGE1900: 1850.2 ~ 1909.8 MHz
 - WCDMA850: 826.4 ~ 846.6 MHz
 - WCDMA1900: 1852.4 ~ 1907.6 MHz
 - HSUPA850: 826.4 ~ 846.6 MHz
 - HSUPA1900: 1852.4 ~ 1907.6 MHz
- Rx Frequency** :
 - GPRS850: 869.2 ~ 893.8 MHz
 - GPRS1900: 1930.2 ~ 1989.8 MHz
 - EDGE850: 824.2 ~ 848.8 MHz
 - EDGE1900: 1850.2 ~ 1909.8 MHz
 - WCDMA850: 871.4 ~ 891.6 MHz
 - WCDMA1900: 1932.4 ~ 1987.6 MHz
 - HSUPA850: 871.4 ~ 891.6 MHz
 - HSUPA1900: 1932.4 ~ 1987.6 MHz
- Max. RF Output Power** :
 - GPRS850: 1.130W EIRP(30.53dBm)
 - GPRS1900: 1.310W EIRP(31.17dBm)
 - EDGE850: 0.324W EIRP(25.11dBm)
 - EDGE1900: 0.359W EIRP(25.55dBm)
 - WCDMA850: 0.160W ERP(22.05dBm)
 - WCDMA1900: 0.189W EIRP(22.76dBm)
 - HSUPA850: 0.140W ERP(21.47dBm)
 - HSUPA1900: 0.175W EIRP(22.44dBm)
- Emission Designator(s)** :
 - GPRS850: 249KGXW
 - GPRS1900: 247KGXW
 - EDGE850: 235KG7W
 - EDGE1900: 241KG7W
 - WCDMA850: 4M17F9W
 - WCDMA1900: 4M17F9W
 - HSUPA850: 4M17F9W
 - HSUPA1900: 4M17F9W

Declaration by the manufacturer

This device supports only GPRS class 10 & Edge class 10 by software.

2. INTRODUCTION

2.1. EUT DESCRIPTION

The Equipment Under Test(EUT) supports a GPRS/EDGE of dual band(Cellular/PCS)and aWCDMA/HSDPA/HSUPAof dual band(Cellular/PCS)withBluetooth, 802.11b/g/n(HT20) and NFC

2.2. MEASURING INSTRUMENT CALIBRATION

The measuring equipment, which was utilized in performing the tests documented herein, has been calibrated in accordance with the manufacturer's recommendations for utilizing calibration equipment, which is traceable to recognized national standards.

2.3. TEST FACILITY

The 3&10M test site and conducted measurement facility used to collect the radiated data are located at the 683-3, Yubang-Dong, Yongin-Si, Gyunggi-Do, 449-080, South Korea. The site is constructed in conformance with the requirements.

- 3&10m test site registration Number: 678747

3. DESCRIPTION OF TESTS

3.1 ERP&EIRP

(Effective Radiated Power & Equivalent Isotropic Radiated Power)

Test Set-up

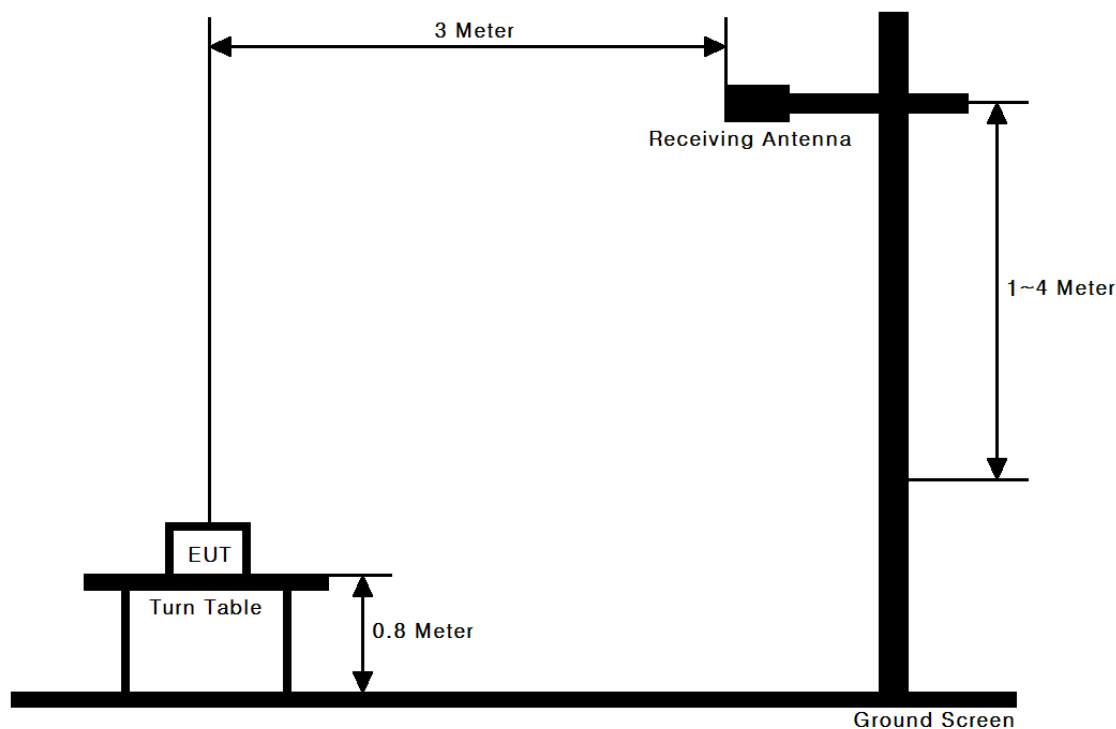

Test Procedure

These measurements were performed at 3&10m test site. The equipment under test is placed on a wooden turntable 0.8-meters above the ground plane and 3-meters from the receive antenna.

The receive antenna height and turntable rotations were adjusted for the highest reading on the receive spectrum analyzer.

A half-wave dipole was substituted in place of the EUT. This dipole antenna was driven by a signal generator and the level of the signal generator was adjusted to obtain the same receive spectrum analyzer reading.

For readings above 1GHz, the above procedure is repeated using horn antennas and the difference between the gain of the horn and an isotropic antenna are taken into consideration.

3.2 PEAK TO AVERAGE RATIO

A peak to average ratio measurement is performed at the conducted port of the EUT. For CDMA and WCDMA signals, the spectrum analyzers Complementary Cumulative Distribution Function (CCDF) measurement profile is used to determine the largest deviation between the average and the peak power of the EUT in a given bandwidth. The CCDF curve shows how much time the peak waveform spends at or above a given average power level. The percent of time the signal spends at or above the level defines the probability for that particular power level.

For GSM signals, an average and a peak trace are used on a spectrum analyzer to determine the largest deviation between the average and the peak power of the EUT in a bandwidth greater than the emission bandwidth. Plots of the EUT's Peak- to- Average Ratio are shown herein.

3.3 OCCUPIED BANDWIDTH.

Test set-up

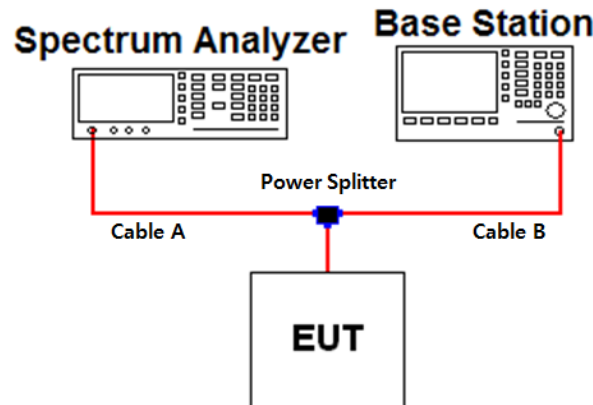

Offset value information

Frequency (MHz)	Offset Value (dB)	Frequency (MHz)	Offset Value (dB)
-	-	-	-
-	-	-	-
-	-	-	-
-	-	-	-
-	-	-	-

Note. 1: The offset values from EUT to Spectrum analyzer were measured and used for test.
 Offset value = Cable A + Splitter + Cable B

Test Procedure

The EUT was setup to maximum output power at its lowest channel. The occupied bandwidth was measured using a spectrum analyzer. The measurements are repeated for the highest and a middle channel. The EUT’s occupied bandwidth is measured as the width of the signal between two points, one below the carrier center frequency and one above the carrier frequency, outside of which all emissions are attenuated at least 26 dB below the transmitter power. Plots of the EUT’s occupied bandwidth are shown herein.

3.4 SPURIOUS AND HARMONIC EMISSIONS AT ANTENNA TERMINAL.

Test set-up

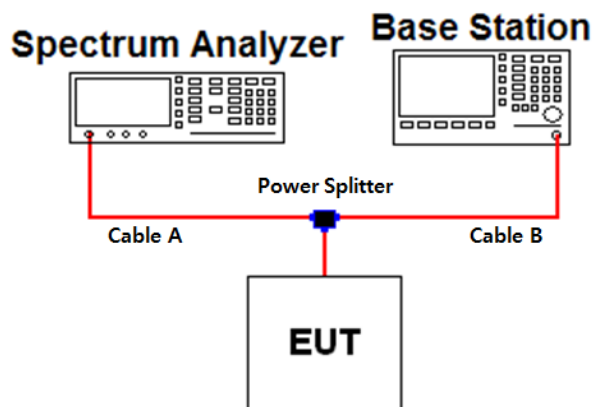

Offset value information

Frequency (MHz)	Offset Value (dB)	Frequency (MHz)	Offset Value (dB)	Frequency (MHz)	Offset Value (dB)
-	-	-	-	-	-
-	-	-	-	-	-
-	-	-	-	-	-
-	-	-	-	-	-

Note. 1: The offset value from EUT to Spectrum analyzer was measured and used for test.
 Offset value = Cable A + Splitter + Cable B

Test Procedure

The level of the carrier and the various conducted spurious and harmonic frequencies is measured by means of a calibrated spectrum analyzer.

The EUT was setup to maximum output power at its lowest channel. The spectrum is scanned from the lowest frequency generated in the equipment up to a frequency including its 10th harmonic. The Resolution BW of the analyzer is set to 1 % of the emission bandwidth to show compliance with -13dBm limit [$43+10\log(P)$], in the 1 MHz bands immediately outside and adjacent to the edge of the frequency block.

A display line was placed at -13dBm to show compliance. The high, lowest and a middle channel were tested for out of band measurements.

Band Edge Requirement

In the 1MHz bands immediately outside and adjacent to the frequency block, a resolution bandwidth of at least 1 percent of the emission bandwidth of the fundamental emission of the transmitter may be employed to measure the out of band Emissions.

3.5 RADIATED SPURIOUS EMISSIONS

Test Set-up

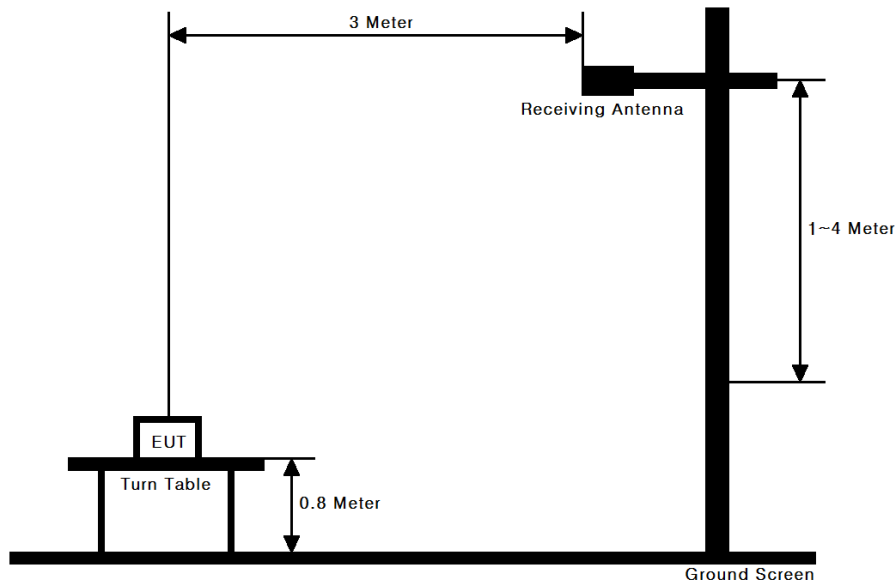

Test Procedure

This measurement was performed at a 3-meter test range. The equipment under test is placed on a wooden turntable 0.8-meters above the ground plane and 3-meters from the receive antenna.

The receive antenna height and turntable rotations were adjusted for the highest reading on the receive spectrum analyzer.

For radiated power measurements below 1GHz, a half-wave dipole was substituted in place of the EUT. This dipole antenna was driven by a signal generator and the level of the signal generator was adjusted to obtain the same spectrum analyzer reading.

For radiated power measurements above 1GHz, a Horn antenna was substituted in place of the EUT. This Horn antenna was driven by a signal generator and the level of the signal generator was adjusted to obtain the same spectrum analyzer reading. The difference between the gain of the horn and an isotropic antenna are taken into consideration.

This measurement was performed with the EUT oriented in 3 orthogonal axis.

3.6 FREQUENCY STABILITY / VARIATION OF AMBIENT TEMPERATURE

Test Set-up

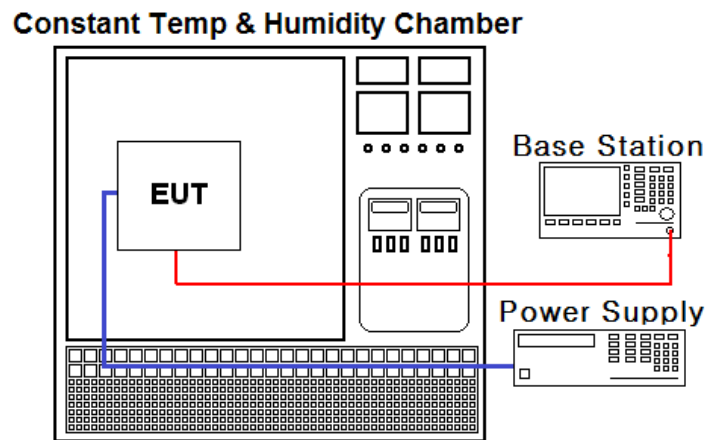

Test Procedure

The frequency stability of the transmitter is measured by:

- a.) **Temperature:** The temperature is varied from - 30 °C to + 50 °C using an environmental chamber.
- b.) **Primary Supply Voltage:** The primary supply voltage is varied from battery end point to 115 % of the voltage normally at the input to the device or at the power supply terminals if cables are not normally supplied.

Specification - the frequency stability shall be sufficient to ensure that the fundamental emission stays within the authorized frequency block. The frequency stability of the transmitter shall be maintained within $\pm 0.00025\%$ (± 2.5 ppm) of the center frequency.

Time Period and Procedure:

The carrier frequency of the transmitter is measured at room temperature. (25°C to provide a reference).

1. The equipment is turned on in a "standby" condition for one minute before applying power to the transmitter. Measurement of the carrier frequency of the transmitter is made within one minute after applying power to the transmitter.
2. Frequency measurements are made at 10°C intervals ranging from -30°C to +50°C. A period of at least one half-hour is provided to allow stabilization of the equipment at each temperature level.

NOTE: The EUT is tested down to the battery endpoint.

4. LIST OF TEST EQUIPMENT

Type	Manufacturer	Model	Cal.Date (yy/mm/dd)	Next.Cal.Date (yy/mm/dd)	S/N
Horn Antenna(18G)	ETS	3115	13/02/28	15/02/28	00021097
Horn Antenna(18G)	ETS	3115	12/02/20	14/02/20	6419
Dipole ANT(30~300MHz)	SCHWARZBECK	VHA 9103	12/03/12	14/03/12	2116
Dipole ANT(30~300MHz)	SCHWARZBECK	VHA 9103	12/03/22	14/03/22	2117
Dipole ANT(300MHz~1.0GHz)	SCHWARZBECK	UHA 9105	12/03/12	14/03/12	2261
Dipole ANT(300MHz~1.0GHz)	SCHWARZBECK	UHA 9105	12/03/22	14/03/22	2262
Attenuator(10dB)	WEINSCHHEL	23-10-34	12/09/17	13/09/17	BP4386
Horn Antenna(18~40GHz)	A.H.Systems Inc.	SAS-574	13/03/20	15/03/20	154
Horn Antenna(18~40GHz)	A.H.Systems Inc.	SAS-574	11/03/25	13/03/25	155
Spectrum Analyzer (3Hz~26.5G)	Agilent Technologies	E4440A	12/09/18	13/09/18	MY45304199
Preamplifier	Agilent	8449B	13/02/27	14/02/27	3008A01590
Signal Generator	Rohde Schwarz	SMR20	13/02/27	14/02/27	101251
High-pass filter	Wainwright Instruments	WHKX2.1	12/09/17	13/09/17	1
8960 Series 10 Wireless Comms Test Set	Agilent Technologies, Inc	E5515C	13/02/28	14/02/28	GB43461134
Vector Signal Generator	Rohde Schwarz	SMJ100A	13/01/08	14/01/08	100148
3dB Attenuator(0-26.5GHz)	Aeroflex/Weinschel	56-3	12/09/17	13/09/17	Y2342
High-pass filter	Wainwright Instruments	WHKX1.0	12/09/17	13/09/17	9
Thermohygrometer	BODYCOM	BJ5478	12/06/20	13/06/20	120612-2
Amplifier	EMPOWER	BBS3Q7ELU	12/09/18	13/09/18	1020
AMPLIFIER	H.P	8447D	12/07/01	13/07/01	2648A04922
BICONICAL ANT.	SCHWARZBECK	VHA 9103	12/10/04	14/10/04	VHA91032789
LOG-PERIODIC ANT.	SCHWARZBECK	UHALP9108A	12/10/04	14/10/04	9108-A0590

5. SUMMARY OF TEST RESULTS

FCC Part Section(s)	RSS Section(s)	Parameter	Status <small>Note 1</small>
2.1046	RSS-132 (4.4) RSS-133 (4.1)	Conducted Output Power	C
22.913(a) 24.232(c)	RSS-132 (4.4) [SRSP-503(5.1.3)] RSS-133 (6.4) [SRSP-510(5.1.2)]	Effective Radiated Power Equivalent Isotropic Radiated Power	C
22.917(a) 24.238(a) 2.1049	RSS-Gen (4.6.1) RSS-133 (2.3)	Occupied Bandwidth	NA <small>Note 2</small>
22.917(a) 24.238(a) 2.1051	RSS-132 (4.5.1) RSS-133 (6.5.1)	Band Edge Spurious and Harmonic Emissions at Antenna Terminal	NA <small>Note 2</small>
24.232(d)	RSS-133 (6.4)	Peak to Average Ratio	NA <small>Note 2</small>
22.917(a) 24.238(a) 2.1053	RSS-132 (4.5.1) RSS-133 (6.5.1)	Radiated Spurious and Harmonic Emissions	C
22.355 24.235 2.1055	RSS-132 (4.3) RSS-133 (6.3)	Frequency Stability	NA <small>Note 2</small>

Note 1: **C**=Comply **NC**=Not Comply **NT**=Not Tested **NA**=Not Applicable
 Note 2: These test items were not performed because this device uses the granted module.(FCCID: QIPPHS8-P)
 Please refer to the test report of the granted module.
 The module test report number:
 - Part 22: MDE_CINTE_1108_FCCd(By 7 Layers AG)
 - Part 24: MDE_CINTE_1108_FCCe(By 7 Layers AG)

The sample was tested according to the following specification:
 ANSI/TIA/EIA-603-C-2004

6. SAMPLE CALCULATION

A. Emission Designator

GPRS850 Emission Designator

Emission Designator = **249KGXW**

EDGE850 Emission Designator

Emission Designator = **235KG7W**

WCDMA850 Emission Designator

Emission Designator = **4M17F9W**

HSUPA850 Emission Designator

Emission Designator = **4M17F9W**

GPRS1900 Emission Designator

Emission Designator = **247KGXW**

EDGE1900 Emission Designator

Emission Designator = **241KG7W**

WCDMA1900 Emission Designator

Emission Designator = **4M17F9W**

HSUPA1900 Emission Designator

Emission Designator = **4M17F9W**

Note: Emission designators of the granted module were used.

7. TEST DATA

7.1 CONDUCTED OUTPUT POWER

A base station simulator was used to establish communication with the EUT. The base station simulator parameters were set to produce the maximum power from the EUT. This device was tested under all configurations and the highest power is reported. Conducted Output Powers of EUT are reported below.

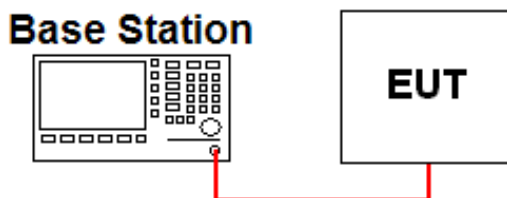

•GPRS & EDGE

Band	Channel	Test Result(dBm)								
		GSM	GPRS 1 TX Slot	GPRS 2 TX Slot	GPRS 3 TX Slot	GPRS 4 TX Slot	EDGE 1 TX Slot	EDGE 2 TX Slot	EDGE 3 TX Slot	EDGE 4 TX Slot
Cellular	128	N/A	33.4	30.3	N/A	N/A	27.2	24.1	N/A	N/A
	190	N/A	33.4	30.3	N/A	N/A	27.2	24.1	N/A	N/A
	251	N/A	33.3	30.2	N/A	N/A	27.2	24.0	N/A	N/A
PCS	512	N/A	31.0	27.8	N/A	N/A	26.8	23.6	N/A	N/A
	661	N/A	30.9	27.8	N/A	N/A	26.7	23.6	N/A	N/A
	810	N/A	30.9	27.7	N/A	N/A	26.7	23.5	N/A	N/A

The output power was measured using the Agilent E5515C

▪ WCDMA & HSDPA

3GPP Release Version	Mode		Power (dBm)			MPR	B _c	β _d	B _c /β _d	Sub-Test
	Channel		4132	4183	4233					
99	WCDMA	RMC	23.46	23.34	23.59	-	-	-	-	-
		ARM	23.42	23.31	23.48					
5	HSDPA (Cellular)		23.40	23.31	23.46	0	2/15	15/15	2/15	1
5			23.38	23.29	23.43	0	12/15	15/15	12/15	2
5			22.89	22.75	22.94	0.5	15/15	8/15	15/8	3
5			22.83	22.70	22.96	0.5	15/15	4/15	15/4	4
-	Channel		9262	9400	9538	-	-	-	-	-
99	WCDMA	RMC	23.08	22.99	23.11	-	-	-	-	-
		ARM	23.05	22.94	23.10					
5	HSDPA (PCS)		22.98	22.92	23.07	0	2/15	15/15	2/15	1
5			22.91	22.89	22.99	0	12/15	15/15	12/15	2
5			22.40	22.39	22.47	0.5	15/15	8/15	15/8	3
5			22.38	22.38	22.44	0.5	15/15	4/15	15/4	4

The output power was measured using the Agilent E5515C

▪ HSUPA

3GPP Release Version	Mode		Power (dBm)			MPR	B _c	β _d	B _c /β _d	Sub-Test
	Channel		4132	4183	4233					
6	HSUPA (Cellular)		23.44	23.31	23.50	0	11/15	15/15	11/15	1
6			21.29	21.18	21.41	2	6/15	15/15	6/15	2
6			22.31	22.24	22.39	1	15/15	9/15	15/9	3
6			21.28	21.19	21.40	2	2/15	15/15	2/15	4
6			23.39	23.25	23.41	0	15/15	15/15	15/15	5
-	Channel		9262	9400	9538	-	-	-	-	-
6	HSUPA (PCS)		23.01	22.95	23.08	0	11/15	15/15	11/15	1
6			21.09	20.88	21.01	2	6/15	15/15	6/15	2
6			22.05	21.78	21.99	1	15/15	9/15	15/9	3
6			20.99	20.90	21.05	2	2/15	15/15	2/15	4
6			22.98	22.95	22.98	0	15/15	15/15	15/15	5

The power was measured E5515C

7.2 EFFECTIVE RADIATED POWER

- GPRS850& EDGE850 data

CH.	EUT Position (Axis)	TEST CONDITIONS Power Step: 5							
		Reading Value (dBm)	Pol. (H/V)	LEVEL@ TX ANTENNA TERMINAL (dBm)	Antenna Gain (dBd)	ERP (dBm)	ERP (W)	Power Supply	Note.
128	X	-5.92	H	26.79	1.20	27.99	0.630	DC 3.7V	GPRS
190	X	-6.37	H	27.63	1.15	28.78	0.755	DC 3.7V	GPRS
251	Y	-6.66	V	29.48	1.05	30.53	1.130	DC 3.7V	GPRS
251	Y	-12.08	V	24.06	1.05	25.11	0.324	DC 3.7V	EDGE

- WCDMA850 data

CH.	EUT Position (Axis)	TEST CONDITIONS							
		Reading Value (dBm)	Pol. (H/V)	LEVEL@ TX ANTENNA TERMINAL (dBm)	Antenna Gain (dBd)	ERP (dBm)	ERP (W)	Power Supply	Note.
4132	Y	-16.41	V	19.89	1.19	21.08	0.128	DC 3.7V	-
4183	X	-13.71	H	20.55	1.15	21.70	0.148	DC 3.7V	-
4233	X	-13.49	H	20.95	1.10	22.05	0.160	DC 3.7V	-

- HSUPA850 data

CH.	EUT Position (Axis)	TEST CONDITIONS							
		Reading Value (dBm)	Pol. (H/V)	LEVEL@ TX ANTENNA TERMINAL (dBm)	Antenna Gain (dBd)	ERP (dBm)	ERP (W)	Power Supply	Note.
4132	Y	-16.74	V	19.56	1.19	20.75	0.119	DC 3.7V	-
4183	X	-13.98	H	20.28	1.15	21.43	0.139	DC 3.7V	-
4233	X	-14.07	H	20.37	1.10	21.47	0.140	DC 3.7V	-

NOTES:

Effective Radiated Power Output Measurements by Substitution Method according to ANSI/TIA/EIA-603-C-2004, Aug. 17, 2004:

The EUT is placed on a wooden turn table 3-meters from the receive antenna. The receive antenna height and turntable rotation is adjusted for the highest reading on the receive spectrum analyzer. For CDMA signals, a peak detector is used, with RBW = VBW = 3 MHz. For WCDMA signals, a peak detector is used, with RBW = VBW = 5MHz. For AMPS, GSM, and TDMA signals, a peak detector is used, with RBW = VBW = 1 MHz.

A half-wave dipole is substituted in place of the EUT. This dipole antenna is driven by a signal generator and the level of the signal generator is adjusted to obtain the same receive spectrum analyzer reading. The conducted power at the terminals of the dipole is measured. The ERP is recorded.

This device was tested under all configurations and the highest power is reported in GSM mode. This EUT was tested with the fully charged battery. Also, we have done x, y, z planes in EUT and horizontal and vertical polarization of detecting antenna.

The worst case data is reported.

7.3 EQUIVALENT ISOTROPIC RADIATED POWER

- GPRS1900 & EDGE1900 data

CH.	EUT Position (Axis)	TEST CONDITIONS Power Step: 0							
		Reading Value (dBm)	Pol. (H/V)	LEVEL@ TX ANTENNA TERMINAL (dBm)	Antenna Gain (dBi)	EIRP (dBm)	EIRP (W)	Power Supply	Note.
512	X	-6.57	H	22.55	8.62	31.17	1.310	DC 3.7V	GPRS
661	X	-6.67	H	22.42	8.71	31.13	1.297	DC 3.7V	GPRS
810	Z	-9.74	V	21.28	8.80	30.08	1.018	DC 3.7V	GPRS
512	X	-12.19	H	16.93	8.62	25.55	0.359	DC 3.7V	EDGE

- WCDMA1900 data

CH.	EUT Position (Axis)	TEST CONDITIONS							
		Reading Value (dBm)	Pol. (H/V)	LEVEL@ TX ANTENNA TERMINAL (dBm)	Antenna Gain (dBi)	EIRP (dBm)	EIRP (W)	Power Supply	Note.
9262	X	-13.76	H	13.88	8.63	22.51	0.178	DC 3.7V	-
9400	Z	-16.05	V	14.05	8.71	22.76	0.189	DC 3.7V	-
9538	Z	-16.75	V	12.90	8.79	21.69	0.148	DC 3.7V	-

- HSUPA 1900 data

CH.	EUT Position (Axis)	TEST CONDITIONS							
		Reading Value (dBm)	Pol. (H/V)	LEVEL@ TX ANTENNA TERMINAL (dBm)	Antenna Gain (dBi)	EIRP (dBm)	EIRP (W)	Power Supply	Note.
9262	Y	-16.02	V	13.69	8.63	22.32	0.171	DC 3.7V	-
9400	Z	-16.76	V	13.34	8.71	22.05	0.160	DC 3.7V	-
9538	Z	-16.00	V	13.65	8.79	22.44	0.175	DC 3.7V	-

NOTES:

Effective Radiated Power Output Measurements by Substitution Method according to ANSI/TIA/EIA-603-C-2004, Aug. 17, 2004:

The EUT is placed on a wooden turn table 3-meters from the receive antenna. The receive antenna height and turntable rotation is adjusted for the highest reading on the receive spectrum analyzer. For CDMA signals, a peak detector is used, with RBW = VBW = 3 MHz. For WCDMA signals, a peak detector is used, with RBW = VBW = 5MHz. For AMPS, GSM, and TDMA signals, a peak detector is used, with RBW = VBW = 1 MHz.

A half-wave dipole is substituted in place of the EUT. This dipole antenna is driven by a signal generator and the level of the signal generator is adjusted to obtain the same receive spectrum analyzer reading. The conducted power at the terminals of the dipole is measured. The ERP is recorded.

This device was tested under all configurations and the highest power is reported in GSM mode. This EUT was tested with the fully charged battery. Also, we have done x, y, z planes in EUT and horizontal and vertical polarization of detecting antenna. The worst case data is reported.

7.4 RADIATED SPURIOUS EMISSIONS

7.4.1 RADIATED SPURIOUS EMISSIONS (GPRS850)

Channel (ERP)	Freq. (MHz)	EUT Position (Axis)	POL (H/V)	LEVEL@ ANTENNA TERMINAL (dBm)	SUBSTITUTE ANTENNA GAIN (dBd)	CORRECT GENERATOR LEVEL (dBm)	(dBc)	Limit (dBc)
128 (0.630W)	1648.23	Z	H	-40.89	5.88	-35.01	63.00	40.99
	2472.57	X	H	-41.98	7.30	-34.68	62.67	
	-	-	-	-	-	-	-	
	-	-	-	-	-	-	-	
190 (0.755W)	1673.30	Z	H	-41.66	5.96	-35.70	64.48	41.78
	2509.78	X	H	-42.62	7.33	-35.29	64.07	
	-	-	-	-	-	-	-	
	-	-	-	-	-	-	-	
251 (1.130W)	1697.50	Z	H	-39.29	6.03	-33.26	63.79	43.53
	2546.45	X	H	-42.19	7.36	-34.83	65.36	
	-	-	-	-	-	-	-	
	-	-	-	-	-	-	-	

- Limit Calculation= 43 + 10 log₁₀(ERP [W]) [dBc]

- No other spurious and harmonic emissions were reported greater than listed emissions above table.

NOTES:

Effective Radiated Power Output Measurements by Substitution Method according to ANSI/TIA/EIA-603-C-2004, Aug. 17, 2004:

The EUT is placed on a wooden turn table 3-meters from the receive antenna. The receive antenna height and turntable rotation is adjusted for the highest reading on the receive spectrum analyzer.

A half-wave dipole was substituted in place of the EUT. This dipole antenna was driven by a signal generator and the level of the signal generator was adjusted to obtain the same receive spectrum analyzer reading. This spurious level is recorded. For readings above 1GHz, the above procedure is repeated using horn antennas and the difference between the gain of the horn and an isotropic or dipole antenna are taken into consideration.

This device was tested under all configurations and the highest power is reported in GSM mode and using a Power Control Level of “0” in the PCS Band and “5” in the Cellular Band.

This EUT was tested with the fully charged battery. Also, we have done x, y, z planes in EUT and horizontal and vertical polarization of detecting antenna.

The worst case data is reported.

7.4.2 RADIATED SPURIOUS EMISSIONS(WCDMA850)

Channel (ERP)	Freq. (MHz)	EUT Position (Axis)	POL (H/V)	LEVEL@ ANTENNA TERMINAL (dBm)	SUBSTITUTE ANTENNA GAIN (dBd)	CORRECT GENERATOR LEVEL (dBm)	(dBc)	Limit (dBc)
4132 (0.128W)	1654.36	X	V	-57.56	5.90	-51.66	72.74	34.08
	-	-	-	-	-	-	-	
	-	-	-	-	-	-	-	
	-	-	-	-	-	-	-	
4183 (0.148W)	1673.32	X	V	-56.21	5.96	-50.25	71.95	34.70
	-	-	-	-	-	-	-	
	-	-	-	-	-	-	-	
	-	-	-	-	-	-	-	
4233 (0.160W)	1691.85	X	V	-58.84	6.01	-52.83	74.88	35.05
	-	-	-	-	-	-	-	
	-	-	-	-	-	-	-	
	-	-	-	-	-	-	-	

- Limit Calculation= $43 + 10 \log_{10}(ERP [W])$ [dBc]

- No other spurious and harmonic emissions were reported greater than listed emissions above table.

NOTES:

Effective Radiated Power Output Measurements by Substitution Method
 according to ANSI/TIA/EIA-603-C-2004, Aug. 17, 2004:

The EUT is placed on a wooden turn table 3-meters from the receive antenna. The receive antenna height and turntable rotation is adjusted for the highest reading on the receive spectrum analyzer.

A half-wave dipole was substituted in place of the EUT. This dipole antenna was driven by a signal generator and the level of the signal generator was adjusted to obtain the same receive spectrum analyzer reading. This spurious level is recorded. For readings above 1GHz, the above procedure is repeated using horn antennas and the difference between the gain of the horn and an isotropic or dipole antenna are taken into consideration.

This device was tested under all configurations and the highest power is reported.

This EUT was tested with the fully charged battery. Also, we have done x, y, z planes in EUT and horizontal and vertical polarization of detecting antenna.

The worst case data is reported.

7.4.3 RADIATED SPURIOUS EMISSIONS(HSUPA850)

Channel (ERP)	Freq. (MHz)	EUT Position (Axis)	POL (H/V)	LEVEL@ ANTENNA TERMINAL (dBm)	SUBSTITUTE ANTENNA GAIN (dBd)	CORRECT GENERATOR LEVEL (dBm)	(dBc)	Limit (dBc)
4132 (0.119W)	1653.20	X	V	-58.72	5.90	-52.82	73.57	33.75
	-	-	-	-	-	-	-	
	-	-	-	-	-	-	-	
	-	-	-	-	-	-	-	
4183 (0.139W)	1674.48	X	V	-58.04	5.96	-52.08	73.51	34.43
	-	-	-	-	-	-	-	
	-	-	-	-	-	-	-	
	-	-	-	-	-	-	-	
4233 (0.140W)	1693.45	X	V	-59.60	6.01	-53.59	75.06	34.47
	-	-	-	-	-	-	-	
	-	-	-	-	-	-	-	
	-	-	-	-	-	-	-	

- Limit Calculation= 43 + 10 log₁₀(ERP [W]) [dBc]

- No other spurious and harmonic emissions were reported greater than listed emissions above table.

NOTES:

Effective Radiated Power Output Measurements by Substitution Method
 according to ANSI/TIA/EIA-603-C-2004, Aug. 17, 2004:

The EUT is placed on a wooden turn table 3-meters from the receive antenna. The receive antenna height and turntable rotation is adjusted for the highest reading on the receive spectrum analyzer.

A half-wave dipole was substituted in place of the EUT. This dipole antenna was driven by a signal generator and the level of the signal generator was adjusted to obtain the same receive spectrum analyzer reading. This spurious level is recorded. For readings above 1GHz, the above procedure is repeated using horn antennas and the difference between the gain of the horn and an isotropic or dipole antenna are taken into consideration.

This device was tested under all configurations and the highest power is reported.

This EUT was tested with the fully charged battery. Also, we have done x, y, z planes in EUT and horizontal and vertical polarization of detecting antenna.

The worst case data is reported.

7.4.4 RADIATED SPURIOUS EMISSIONS (GPRS1900)

Channel (EIRP)	Freq. (MHz)	EUT Position (Axis)	POL (H/V)	LEVEL@ ANTENNA TERMINAL (dBm)	SUBSTITUTE ANTENNA GAIN (dBi)	CORRECT GENERATOR LEVEL (dBm)	(dBc)	Limit (dBc)
512 (1.310W)	3700.55	Z	H	-53.82	9.60	-44.22	75.39	44.17
	-	-	-	-	-	-	-	
	-	-	-	-	-	-	-	
	-	-	-	-	-	-	-	
661 (1.297W)	3760.10	Z	H	-52.45	9.58	-42.87	74.00	44.13
	-	-	-	-	-	-	-	
	-	-	-	-	-	-	-	
	-	-	-	-	-	-	-	
810 (1.018W)	3819.54	Z	H	-49.02	9.55	-39.47	69.54	43.08
	-	-	-	-	-	-	-	
	-	-	-	-	-	-	-	
	-	-	-	-	-	-	-	

- Limit Calculation = $43 + 10 \log_{10}(\text{EIRP [W]})$ [dBc]

- No other spurious and harmonic emissions were reported greater than listed emissions above table.

NOTES:

Effective Radiated Power Output Measurements by Substitution Method according to ANSI/TIA/EIA-603-C-2004, Aug. 17, 2004:

The EUT is placed on a wooden turn table 3-meters from the receive antenna. The receive antenna height and turntable rotation is adjusted for the highest reading on the receive spectrum analyzer.

A half-wave dipole was substituted in place of the EUT. This dipole antenna was driven by a signal generator and the level of the signal generator was adjusted to obtain the same receive spectrum analyzer reading. This spurious level is recorded. For readings above 1GHz, the above procedure is repeated using horn antennas and the difference between the gain of the horn and an isotropic or dipole antenna are taken into consideration.

This device was tested under all configurations and the highest power is reported in GSM mode and using a Power Control Level of "0" in the PCS Band and "5" in the Cellular Band.

This EUT was tested with the fully charged battery. Also, we have done x, y, z planes in EUT and horizontal and vertical polarization of detecting antenna.

The worst case data is reported.

7.4.5 RADIATED SPURIOUS EMISSIONS(WCDMA1900)

Channel (EIRP)	Freq. (MHz)	EUT Position (Axis)	POL (H/V)	LEVEL@ ANTENNA TERMINAL (dBm)	SUBSTITUTE ANTENNA GAIN (dBi)	CORRECT GENERATOR LEVEL (dBm)	(dBc)	Limit (dBc)
9262 (0.178W)	3704.68	Y	V	-48.06	9.60	-38.46	60.97	35.51
	-	-	-	-	-	-	-	
	-	-	-	-	-	-	-	
	-	-	-	-	-	-	-	
9400 (0.189W)	3760.10	Y	V	-48.92	9.58	-39.34	62.10	35.76
	-	-	-	-	-	-	-	
	-	-	-	-	-	-	-	
	-	-	-	-	-	-	-	
9538 (0.148W)	3813.80	Y	V	-48.03	9.56	-38.47	60.16	34.69
	-	-	-	-	-	-	-	
	-	-	-	-	-	-	-	
	-	-	-	-	-	-	-	

- Limit Calculation = $43 + 10 \log_{10}(\text{EIRP [W]})$ [dBc]

- No other spurious and harmonic emissions were reported greater than listed emissions above table.

NOTES:

Effective Radiated Power Output Measurements by Substitution Method according to ANSI/TIA/EIA-603-C-2004, Aug. 17, 2004:

The EUT is placed on a wooden turn table 3-meters from the receive antenna. The receive antenna height and turntable rotation is adjusted for the highest reading on the receive spectrum analyzer.

A half-wave dipole was substituted in place of the EUT. This dipole antenna was driven by a signal generator and the level of the signal generator was adjusted to obtain the same receive spectrum analyzer reading. This spurious level is recorded. For readings above 1GHz, the above procedure is repeated using horn antennas and the difference between the gain of the horn and an isotropic or dipole antenna are taken into consideration.

This device was tested under all configurations and the highest power is reported in GSM mode and using a Power Control Level of "0" in the PCS Band and "5" in the Cellular Band.

This EUT was tested with the fully charged battery. Also, we have done x, y, z planes in EUT and horizontal and vertical polarization of detecting antenna.

The worst case data is reported.

7.4.6 RADIATED SPURIOUS EMISSIONS(HSUPA1900)

Channel (EIRP)	Freq. (MHz)	EUT Position (Axis)	POL (H/V)	LEVEL@ ANTENNA TERMINAL (dBm)	SUBSTITUTE ANTENNA GAIN (dBi)	CORRECT GENERATOR LEVEL (dBm)	(dBc)	Limit (dBc)
9262 (0.171W)	3704.96	Y	V	-49.53	9.60	-39.93	62.25	35.32
	-	-	-	-	-	-	-	
	-	-	-	-	-	-	-	
	-	-	-	-	-	-	-	
9400 (0.160W)	3759.80	Y	V	-48.50	9.58	-38.92	60.97	35.05
	-	-	-	-	-	-	-	
	-	-	-	-	-	-	-	
	-	-	-	-	-	-	-	
9538 (0.175W)	3815.45	Y	V	-46.76	9.56	-37.20	59.64	35.44
	-	-	-	-	-	-	-	
	-	-	-	-	-	-	-	
	-	-	-	-	-	-	-	

- Limit Calculation = $43 + 10 \log_{10}(\text{EIRP [W]})$ [dBc]

- No other spurious and harmonic emissions were reported greater than listed emissions above table.

NOTES:

Effective Radiated Power Output Measurements by Substitution Method according to ANSI/TIA/EIA-603-C-2004, Aug. 17, 2004:

The EUT is placed on a wooden turn table 3-meters from the receive antenna. The receive antenna height and turntable rotation is adjusted for the highest reading on the receive spectrum analyzer.

A half-wave dipole was substituted in place of the EUT. This dipole antenna was driven by a signal generator and the level of the signal generator was adjusted to obtain the same receive spectrum analyzer reading. This spurious level is recorded. For readings above 1GHz, the above procedure is repeated using horn antennas and the difference between the gain of the horn and an isotropic or dipole antenna are taken into consideration.

This device was tested under all configurations and the highest power is reported in GSM mode and using a Power Control Level of "0" in the PCS Band and "5" in the Cellular Band.

This EUT was tested with the fully charged battery. Also, we have done x, y, z planes in EUT and horizontal and vertical polarization of detecting antenna.

The worst case data is reported.