

# SAR TEST REPORT

<p><b>DT&amp;C Co., Ltd.</b>          42, Yurim-ro, 154Beon-gil, Cheoin-gu, Yongin-si,          Gyeonggi-do, Korea          Tel: 031-321-2664, Fax : 031-321-1664</p>	<p>Report No : DRRFCC1511-0101(1)          Pages:(1) / (167) page</p>	
---	---	---

1. Customer

- Name : BLUEBIRD INC.
- Address : (Dogok-dong, SEI Tower 13,14) 39, Eonjuro30-gil, Gangnam-gu, Seoul, South Korea

2. Use of Report : FCC Original Grant

3. Product Name (FCC ID): Enterprise Handheld Computer (FCC ID : SS4EF500)

4. Date of Test :2015-08-27 ~ 2015-12-05

5. Test Method Used: CFR §2.1093

6. Testing Environment :See appended test report

7. Test Result :  Pass  Fail

The results shown in this test report refer only to the sample(s) tested unless otherwise stated. This Test Report cannot be reproduced, except in full.

Affirmation	Tested by Name :BumJun,Park <i>(Signature)</i>	Technical Manager Name : Harvey Sung <i>(Signature)</i>
-------------	---	--

2015. 12. 07.

DT&C Co., Ltd.



## Test Report Version

Test Report No.	Date	Description
DRRFCC1511-0101	Nov. 19, 2015	Initial issue
DRRFCC1511-0101(1)	Dec. 7, 2015	Add composition mixtures information. Add U-NII Band Head SAR Data.



**Table of Contents**

**1. DESCRIPTION OF DEVICE.....5**

    1.1 Guidance Applied ..... 7

    1.2 Device Overview..... 7

    1.3 Nominal and Maximum Output Power Specifications ..... 7

    1.4 DUT Antenna Locations ..... 10

    1.5 Near Field Communications (NFC) Antenna..... 11

    1.6 SAR Test Exclusions Applied ..... 11

    1.7 Power Reduction for SAR..... 12

    1.8 Device Serial Numbers ..... 12

    1.9 LTE Information ..... 13

**2. INTROCUCTION ..... 14**

**3. DESCRIPTION OF TEST EQUIPMENT..... 15**

    3.1 SAR MEASUREMENT SETUP..... 15

    3.2 EX3DV4Probe Specification ..... 16

    3.3 Probe Calibration Process ..... 17

        3.3.1 E-Probe Calibration ..... 17

    3.4 Data Extrapolation ..... 18

    3.5 SAM Twin PHANTOM..... 19

    3.6 Modular Flat PHANTOM..... 20

    3.7 Device Holder for Transmitters ..... 20

    3.8 Brain & Muscle Simulation Mixture Characterization ..... 21

    3.9 SAR TEST EQUIPMENT ..... 23

**4. TEST SYSTEM SPECIFICATIONS ..... 24**

**5. SAR MEASUREMENT PROCEDURE ..... 25**

    5.1 Measurement Procedure ..... 25

**6. DEFINITION OF REFERENCE POINTS ..... 26**

    6.1 Ear Reference Point ..... 26

    6.2 Handset Reference Points ..... 26

**7. TEST CONFIGURATION POSITIONS FOR HANDSETS..... 27**

    7.1 Device Holder ..... 27

    7.2 Positioning for Cheek/Touch ..... 27

    7.3 Positioning for Ear / 15 ° Tilt ..... 27

    7.4 Body-Worn Accessory Configurations ..... 28

    7.5 Extremity Exposure Configurations ..... 28

    7.6 Wireless Router Configurations ..... 29

**8. RF EXPOSURE LIMITS ..... 30**

**9. FCC MEASUREMENT PROCEDURES..... 31**

    9.1 Measured and Reported SAR..... 31

    9.2 Procedures Used to Establish RF Signal for SAR ..... 31

    9.3 SAR Measurement Conditions for CDMA2000 ..... 31

        9.3.1 Output Power Verification ..... 31

        9.3.2 CDMA 2000 1x Advanced ..... 32

        9.3.3 Head SAR Measurements ..... 32

        9.3.4 Body SAR Measurements ..... 32

    9.4 SAR Measurement Conditions for WCDMA (UMTS) ..... 33

        9.4.1 Output Power Verification ..... 33

        9.4.2 Head SAR Measurements for Handsets..... 33

        9.4.3 Body SAR Measurements ..... 33

        9.4.4 Release 5 HSDPA Data Devices ..... 33

        9.4.5 Release 6 HSUPA Data Devices ..... 34

    9.5 SAR Measurement Conditions for LTE ..... 35

        9.5.1 Spectrum Plots for RB Configurations ..... 35



9.5.2 MPR.....	35
9.5.3 A-MPR .....	35
9.5.4 Required RB Size and RB Offsets for SAR Testing .....	35
9.6 SAR Testing with 802.11 Transmitters .....	36
9.6.1 General Device Setup.....	36
9.6.2 U-NII and U-NII-2A .....	36
9.6.3 U-NII-2C and U-NII-3 .....	36
9.6.4 Initial Test Position Procedure.....	36
9.6.5 2.4 GHz SAR Test Requirements .....	37
9.6.6 OFDM Transmission Mode and SAR Test Channel Selection .....	37
9.6.7 Initial Test Configuration Procedure .....	37
9.6.8 Subsequent Test Configuration Procedures .....	37
<b>10. RF CONDUCTED POWERS .....</b>	<b>38</b>
10.1 CDMA Conducted Powers .....	38
10.2 GSM Conducted Powers .....	39
10.3 WCDMA Conducted Powers.....	40
10.4 LTE Conducted Powers .....	41
10.5 WLAN Conducted Powers .....	44
10.6 Bluetooth Conducted Powers .....	47
<b>11. SYSTEM VERIFICATION .....</b>	<b>48</b>
11.1 Tissue Verification .....	48
11.2 Test System Verification .....	50
<b>12. SAR TEST RESULTS .....</b>	<b>51</b>
12.1 Head SAR Results.....	51
12.2 Standalone Body-Worn SAR Worn SAR Results.....	57
12.3 Standalone Wireless router SAR Results .....	59
12.4 SAR Test Notes .....	64
<b>13. FCC MULTI-TX AND ANTENNA SAR CONSIDERATIONS .....</b>	<b>66</b>
13.1 Introduction.....	66
13.2 Simultaneous Transmission Procedures.....	66
13.3 Simultaneous Transmission Capabilities .....	66
13.4 Head SAR Simultaneous Transmission Analysis .....	69
13.5 Body-Worn Simultaneous Transmission Analysis .....	73
13.6 Hotspot SAR Simultaneous Transmission Analysis .....	74
13.7 Simultaneous Transmission Conclusion .....	75
<b>14. SAR MEASUREMENT VARIABILITY .....</b>	<b>76</b>
14.1 Measurement Variability .....	76
14.2 Measurement Uncertainty.....	76
<b>15. IEEE P1528 –MEASUREMENT UNCERTAINTIES .....</b>	<b>77</b>
<b>16. CONCLUSION .....</b>	<b>90</b>
<b>17. REFERENCES .....</b>	<b>91</b>
<b>Attachment 1. – Probe Calibration Data .....</b>	<b>93</b>
<b>Attachment 2. – Dipole Calibration Data.....</b>	<b>105</b>
<b>Attachment 3. – SAR SYSTEM VALIDATION .....</b>	<b>166</b>

## 1. DESCRIPTION OF DEVICE

Environmental evaluation measurements of specific absorption rate (SAR) distributions in emulated human head and body tissues exposed to radio frequency (RF) radiation from wireless portable devices for compliance with the rules and regulations of the U.S. Federal Communications Commission (FCC).

### General Information

EUT type	Enterprise Handheld Computer			
FCC ID	SS4EF500			
Equipment model name	EF500			
Equipment add model name	EF500R 2 models are same mechanical, electrical and functional. The only difference is the model name, which are changed for marketing purpose.			
Equipment serial no.	Identical prototype			
Mode(s) of Operation	CDMA 850, CDMA 1900, GSM 850, GSM 1900, WCDMA 850, WCDMA 1900, LTE Band 2, 4, 5, 17, 2.4 GHz W-LAN(802.11b/g/n HT20), 5 G W-LAN (802.11a/n HT20/n HT40)			
TX Frequency Range	<b>Band</b>	<b>Mode</b>	<b>Bandwidth</b>	<b>Frequency</b>
	CDMA 850	CDMA	-	824.7 ~ 848.31 MHz
	CDMA 1900	CDMA	-	1851.25 ~ 1908.75 MHz
	GSM 850	GSM/GPRS/EDGE	-	824.2 ~ 848.8 MHz
	GSM 1900	GSM/GPRS/EDGE	-	1850.2 ~ 1909.8 MHz
	WCDMA 850	WCDMA	-	826.4 ~ 846.6 MHz
	WCDMA 1900	WCDMA	-	1852.4 ~ 1907.6 MHz
	LTE Band 17	LTE	10 MHz	709 ~ 711 MHz
	LTE Band 5(Cell)	LTE	10 MHz	829 ~ 844 MHz
	LTE Band 4(AWS)	LTE	10 MHz	1715 ~ 1750 MHz
	LTE Band 2(PCS)	LTE	10 MHz	1855 ~ 1905 MHz
	DTS	802.11b/g/n HT20	HT20	2412 ~ 2462 MHz
	U-NII-1	802.11a/n HT20	HT20	5180 ~ 5240 MHz
		802.11n HT40	HT40	5190 ~ 5230 MHz
	U-NII-2A	802.11a/n HT20	HT20	5260 ~ 5320 MHz
		802.11n HT40	HT40	5270 ~ 5310 MHz
	U-NII-2C	802.11a/n HT20	HT20	5500 ~ 5700 MHz
		802.11n HT40	HT40	5510 ~ 5670 MHz
	U-NII-3	802.11a/n HT20	HT20	5745 ~ 5825 MHz
		802.11n HT40	HT40	5755 ~ 5795 MHz
	RX Frequency Range	CDMA 850	CDMA	-
CDMA 1900		CDMA	-	1931.25 ~ 1988.75 MHz
GSM 850		GSM/GPRS/EDGE	-	869.2 ~ 893.8 MHz
GSM 1900		GSM/GPRS/EDGE	-	1930.2 ~ 1989.8 MHz
WCDMA 850		WCDMA	-	871.4 ~ 891.6 MHz
WCDMA 1900		WCDMA	-	1932.4 ~ 1987.6 MHz
LTE Band 17		LTE	10 MHz	739 ~ 741 MHz
LTE Band 5(Cell)		LTE	10 MHz	874 ~ 889 MHz
LTE Band 4(AWS)		LTE	10 MHz	2115 ~ 2150 MHz
LTE Band 2(PCS)		LTE	10 MHz	1935 ~ 1985 MHz
DTS		802.11b/g/n HT20	HT20	2412 ~ 2462 MHz
U-NII-1		802.11a/n HT20	HT20	5180 ~ 5240 MHz
		802.11n HT40	HT40	5190 ~ 5230 MHz
U-NII-2A		802.11a/n HT20	HT20	5260 ~ 5320 MHz
		802.11n HT40	HT40	5270 ~ 5310 MHz
U-NII-2C		802.11a/n HT20	HT20	5500 ~ 5700 MHz
		802.11n HT40	HT40	5510 ~ 5670 MHz
U-NII-3		802.11a/n HT20	HT20	5745 ~ 5825 MHz
		802.11n HT40	HT40	5755 ~ 5795 MHz



Band	Mode	Measured Conducted Power [dBm]	Ch	Reported SAR		
				1g SAR (W/kg)		
				Head	Body-worn	Hotspot
PCE	CDMA 850	24.51	384	0.22	0.27	0.27
PCE	CDMA 1900	24.04	600	0.10	0.99	1.11
PCE	GSM 850	33.32	190	0.14	0.18	N/A
PCE	GPRS 850	29.28	190	0.27	0.35	0.35
PCE	GSM 1900	30.17	661	0.03	0.68	N/A
PCE	GPRS 1900	26.34	661	0.08	0.73	0.99
PCE	WCDMA 850	23.96	4183	0.19	0.22	0.22
PCE	WCDMA 1900	23.62	9400	0.07	0.75	1.11
PCE	LTE Band 17	23.87	23790	0.10	0.23	0.23
PCE	LTE Band 5	23.88	20525	0.13	0.15	0.15
PCE	LTE Band 4	22.90	20175	0.02	0.33	0.37
PCE	LTE Band 2	23.19	18900	0.10	0.87	0.93
DTS	2.4 GHz W-LAN	16.61	11	0.10	N/A	0.16
U-NII-2A	5.3 GHz W-LAN	10.80	52	0.05	N/A	N/A
U-NII-2C	5.6 GHz W-LAN	10.50	116	0.04	N/A	N/A
U-NII-3	5.8 GHz W-LAN	10.34	149	0.06	N/A	N/A
DSS	Bluetooth	7.00	N/A	N/A	0.12 <sup>Note</sup>	N/A
Simultaneous SAR per KDB 690783 D01v01r03			N/A	0.37	1.11	1.11
FCC Equipment Class	PCS Licensed Transmitter held to ear (PCE) Part 15 Spread Spectrum Transmitter (DSS) Digital Transmission System (DTS) Unlicensed National Information Infrastructure (UNII)					
Date(s) of Tests	2015-08-27 ~ 2015-12-05					
Antenna Type	Internal Type Antenna					
Note	Bluetooth SAR was estimated.					
Functions	<ul style="list-style-type: none"> <li>● GSM/GPRS (GPRS Class: 12) / EDGE (EDGE Class: 12) supported</li> <li>* DTM not supported</li> <li>● BT(2.4GHz) / W-LAN(2.4GHz 802.11b/g/n(HT20)) supported</li> <li>W-LAN(5GHz 802.11a/n(HT20)/n(HT40)) supported</li> <li>* No simultaneous transmission between BT &amp; WLAN</li> <li>● GPRS, WCDMA, LTE, W-LAN VoIP supported.</li> <li>● WiFi 2.4GHz Mobile Hotspot supported.</li> <li>● LTE Band(B2, B4, B5, B17) is only 10 MHz bandwidth support.</li> <li>● Simultaneous transmission between GSM, WCDMA voice + WLAN / GPRS, WCDMA + WLAN / LTE + WLAN</li> </ul>					

## 1.1 Guidance Applied

- IEEE 1528-2013
- FCC KDB Publication 941225 D01 3G SAR Procedures v03r01
- FCC KDB Publication 941225 D05 SAR for LTE Devices v02r04
- FCC KDB Publication 941225 D06 Hot Spot SAR v02r01
- FCC KDB Publication 248227 D01v02r02 (802.11 Wi-Fi SAR)
- FCC KDB Publication 447498 D01v06 (General RF Exposure Guidance)
- FCC KDB Publication 648474 D04 Handset SAR v01r03
- FCC KDB Publication 690783 D01 SAR Listings on Grants v01r03
- FCC KDB Publication 865664 D01 SAR Measurement 100 MHz to 6 GHz v01r04
- FCC KDB Publication 865664 D02 RF Exposure Reporting v01r02
- October 2013 TCB Workshop Notes (GPRS testing criteria)

## 1.2 Device Overview

Band	Mode	Operating Modes	Tx Frequency
PCE	CDMA 850	Voice/Data	824.7 ~ 848.31 MHz
	CDMA 1900	Voice/Data	1851.25 ~ 1908.75 MHz
	GSM/GPRS/EDGE 850	Voice/Data	824.2 ~ 848.8 MHz
	GSM/GPRS/EDGE 1900	Voice/Data	1850.2 ~ 1909.8 MHz
	WCDMA 850	Voice/Data	826.4 ~ 846.6 MHz
	WCDMA 1900	Voice/Data	1852.4 ~ 1907.6 MHz
	LTE Band 17	Data	706.5 ~ 713.5 MHz
	LTE Band 5	Data	824.7 ~ 848.3 MHz
	LTE Band 4	Data	1710.7 ~ 1754.3 MHz
	LTE Band 2	Data	1850.7 ~ 1909.3 MHz
DTS	2.4 GHz WLAN	Data	2412 ~ 2462 MHz
U-NII-1	5.2 GHz WLAN	Data	5180 ~ 5240 MHz
U-NII-2A	5.3 GHz WLAN	Data	5260 ~ 5320 MHz
U-NII-2C	5.6 GHz WLAN	Data	5500 ~ 5700 MHz
U-NII-3	5.8 GHz WLAN	Data	5745 ~ 5825 MHz
DSS	Bluetooth	Data	2402 ~ 2480 MHz

## 1.3 Nominal and Maximum Output Power Specifications

This device operates using the following maximum and nominal output power specifications. SAR values were scaled to the maximum allowed power to determine compliance per KDB Publication 447498 D01v06.

Band & Mode		Modulated Average [dBm]	
PCE	CDMA 850	Maximum	25.0
		Nominal	24.5
	CDMA 1900	Maximum	24.2
		Nominal	23.7



Band & Mode			Voice [dBm]	Burst Average GMSK [dBm]				Burst Average 8-PSK [dBm]			
			1 TX Slot	1 TX Slot	2 TX Slot	3 TX Slot	4 TX Slot	1 TX Slot	2 TX Slot	3 TX Slot	4 TX Slot
PCE	GSM/GPRS/EDGE 850	Maximum	33.5	33.5	31.7	29.9	29.3	27.7	27.2	26.9	26.3
		Nominal	33.0	33.0	31.2	29.4	28.8	27.2	26.7	26.4	25.8
	GSM/GPRS/EDGE 1900	Maximum	30.2	30.2	28.8	27.5	26.4	26.2	25.8	25.2	24.8
		Nominal	29.7	29.7	28.3	27.0	25.9	25.7	25.3	24.7	24.3

Band & Mode			Modulated Average [dBm]				
			3GPP WCDMA	3GPP HSDPA			
				Rel. 5			
Rel. 99	Subtest 1	Subtest 2	Subtest 3	Subtest 4			
	PCE	WCDMA 850	Maximum	24.2	24.2	24.2	23.7
Nominal			23.7	23.7	23.7	23.2	23.2
WCDMA 1900		Maximum	23.7	23.7	23.7	23.2	23.2
		Nominal	23.2	23.2	23.2	22.7	22.7

Note : This device supports HSUPA but the manufacturer declares that the HSUPA transmitter's power will not exceed the R99 maximum transmit power in devices based on Qualcomm's HSPA chipset solution. Please refer to the tune-up procedure.

Band & Mode			Modulated Average [dBm]
PCE	LTE Band 17	Maximum	24.0
		Nominal	23.5
	LTE Band 5(Cell)	Maximum	24.0
		Nominal	23.5
	LTE Band 4(AWS)	Maximum	23.0
		Nominal	22.5
	LTE Band 2(PCS)	Maximum	23.2
		Nominal	22.7

Band & Mode			Modulated Average[dBm]		
			Ch Low	Ch Mid	Ch High
DTS	IEEE 802.11b (2.4 GHz)	Maximum	16.7	16.7	16.7
		Nominal	15.7	15.7	15.7
	IEEE 802.11g (2.4 GHz)	Maximum	13.3	13.3	11.6
		Nominal	12.3	12.3	10.6
	IEEE 802.11n HT20 (2.4 GHz)	Maximum	11.6	11.6	11.6
		Nominal	10.6	10.6	10.6





Band & Mode			Modulated Average[dBm]
U-NII-1	IEEE 802.11a/n HT20/n HT40 (5.2 GHz)	Maximum	11.0
		Nominal	10.0
U-NII-2A	IEEE 802.11a/n HT20/n HT40(5.3 GHz)	Maximum	11.0
		Nominal	10.0
U-NII-2C	IEEE 802.11a/n HT20/n HT40(5.6 GHz)	Maximum	10.6
		Nominal	9.6
U-NII-3	IEEE 802.11a/n HT20/n HT40(5.8 GHz)	Maximum	10.5
		Nominal	9.5

Band & Mode			Modulated Average[dBm]		
			Ch Low	Ch Mid	Ch High
DSS	Bluetooth 1 Mbps	Maximum	6.0	7.5	6.0
		Nominal	5.0	6.5	5.0
	Bluetooth 2 Mbps	Maximum	3.5	5.0	3.5
		Nominal	2.5	4.0	2.5
	Bluetooth 3 Mbps	Maximum	3.5	5.0	3.5
		Nominal	2.5	4.0	2.5
DTS	Bluetooth LE	Maximum	-3.5	-3.0	-4.0
		Nominal	-4.5	-4.0	-5.0

### 1.4 DUT Antenna Locations

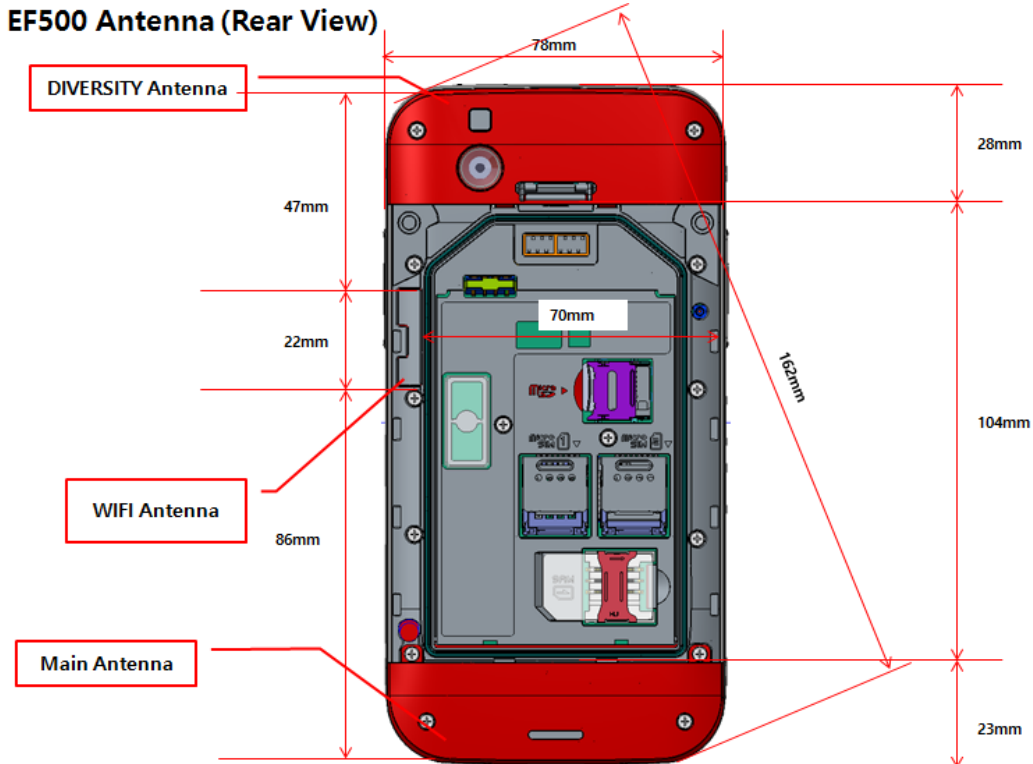

Note 1: Exact antenna dimensions and separation distances are shown in the “Antenna Location\_SS4EF500” in the FCC Filing.  
 Note 2: Since the diagonal dimension of this device is > 160 mm, it is considered a “phablet”.

Mode	Mobile Hotspot Sides for SAR Testing					
	Top	Bottom	Front	Rear	Right	Left
CDMA 850	X	O	O	O	O	O
CDMA 1900	X	O	O	O	O	O
GSM 850	X	O	O	O	O	O
GSM 1900	X	O	O	O	O	O
WCDMA 850	X	O	O	O	O	O
WCDMA 1900	X	O	O	O	O	O
LTE Band 17	X	O	O	O	O	O
LTE Band 5	X	O	O	O	O	O
LTE Band 4	X	O	O	O	O	O
LTE Band 2	X	O	O	O	O	O
2.4G W-LAN(802.11b)	X	X	O	O	O	X

Note: Particular DUT edges were not required to be evaluated for Wireless Router SAR if the edges were greater than 2.5 cm from the transmit antenna according to FCC KDB Publication 941225 D06v02r01 guidance, page 2. The antenna document shows the distances between the transmit antennas and the edges of the device.

### 1.5 Near Field Communications (NFC) Antenna

This DUT has NFC operations. The NFC antenna is integrated into the back cover. The SAR tests were performed with the back cover with NFC antenna already incorporated.

#### EF500 Antenna

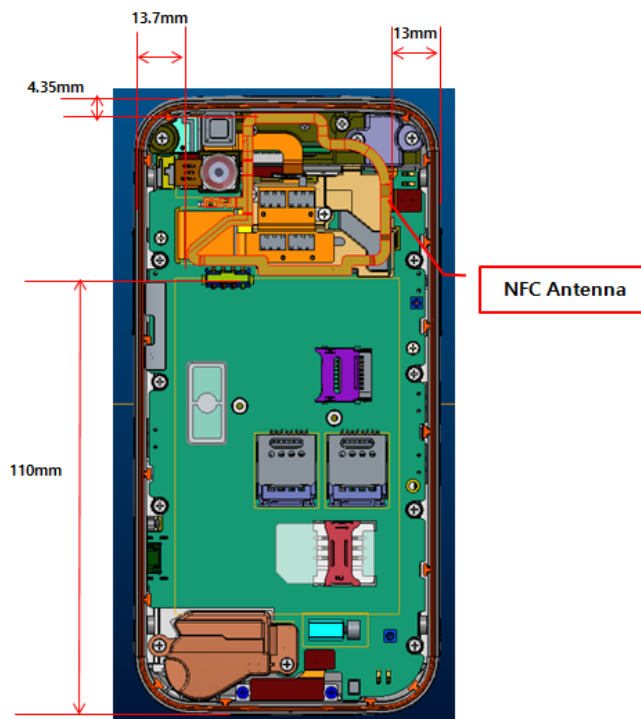

### 1.6 SAR Test Exclusions Applied

#### (A) WIFI & BT

Since Wireless Router operations of this device are only allowed using 2.4 GHz WIFI, only 2.4 GHz WIFI Hotspot SAR tests and combinations are considered for SAR with respect to Wireless Router configurations according to FCC KDB 941225 D06v02r01.

Per FCC KDB 447498 D01v06, the SAR exclusion threshold for distances < 50 mm is defined by the following equation:

$$\frac{\text{Max Power of Channel (mW)}}{\text{Test Separation Dist (mm)}} * \sqrt{\text{Frequency(GHz)}} \leq 3.0$$

Based on the maximum conducted power of **Bluetooth** (rounded to the nearest mW) and the antenna to user separation distance, **Bluetooth SAR was not required**;  $[(6/10) * \sqrt{2.441}] = \mathbf{0.9} < 3.0$ .

Based on the maximum conducted power of **Bluetooth LE** (rounded to the nearest mW) and the antenna to user separation distance, **Bluetooth LE SAR was not required**;  $[(1/10) * \sqrt{2.440}] = \mathbf{0.1} < 3.0$ .

Based on the maximum conducted power of **2.4 GHz WIFI** (rounded to the nearest mW) and the antenna to user separation distance, **2.4 GHz WIFI SAR was required**;  $[(47/10) * \sqrt{2.462}] = \mathbf{7.3} > 3.0$ .

Based on the maximum conducted power of **5.2 GHz WIFI Head** (rounded to the nearest mW) and the antenna to user separation distance, **5.2 GHz WIFI Head SAR was required**;  $[(13/5)^* \sqrt{5.240}] = \underline{5.8} > 3.0$ .

Based on the maximum conducted power of **5.3 GHz WIFI Head** (rounded to the nearest mW) and the antenna to user separation distance, **5.3 GHz WIFI Head SAR was required**;  $[(13/5)^* \sqrt{5.320}] = \underline{5.8} > 3.0$ .

Based on the maximum conducted power of **5.6 GHz WIFI Head** (rounded to the nearest mW) and the antenna to user separation distance, **5.6 GHz WIFI Head SAR was required**;  $[(11/5)^* \sqrt{5.700}] = \underline{5.5} > 3.0$ .

Based on the maximum conducted power of **5.8 GHz WIFI Head** (rounded to the nearest mW) and the antenna to user separation distance, **5.8 GHz WIFI Head SAR was required**;  $[(11/5)^* \sqrt{5.825}] = \underline{5.4} > 3.0$ .

Based on the maximum conducted power of **5.2 GHz WIFI Body** (rounded to the nearest mW) and the antenna to user separation distance, **5.2 GHz WIFI Body SAR was not required**;  $[(13/10)^* \sqrt{5.240}] = \underline{2.9} < 3.0$ .

Based on the maximum conducted power of **5.3 GHz WIFI Body** (rounded to the nearest mW) and the antenna to user separation distance, **5.3 GHz WIFI Body SAR was not required**;  $[(13/10)^* \sqrt{5.320}] = \underline{2.9} < 3.0$ .

Based on the maximum conducted power of **5.6 GHz WIFI Body** (rounded to the nearest mW) and the antenna to user separation distance, **5.6 GHz WIFI Body SAR was not required**;  $[(11/10)^* \sqrt{5.700}] = \underline{2.7} < 3.0$ .

Based on the maximum conducted power of **5.8 GHz WIFI Body** (rounded to the nearest mW) and the antenna to user separation distance, **5.8 GHz WIFI Body SAR was not required**;  $[(11/10)^* \sqrt{5.825}] = \underline{2.7} < 3.0$ .

Per KDB Publication 447498 D01v06, the maximum power of the channel was rounded to the nearest mW before calculation.

## (B) Licensed Transmitter(s)

GSM/GPRS DTM is not supported for US bands. Therefore, the GSM Voice modes in this report do not transmit simultaneously with GPRS/EDGE Data.

### 1.7 Power Reduction for SAR

There is no power reduction used for any band/mode implemented in this device for SAR purposes.

### 1.8 Device Serial Numbers

Band & Mode	Head Serial Number	Hotspot Serial Number
CDMA 850	FCC #1	FCC #1
CDMA 1900	FCC #1	FCC #1
GSM/GPRS 850	FCC #1	FCC #1
GSM/GPRS 1900	FCC #1	FCC #1
WCDMA 850	FCC #1	FCC #1
WCDMA 1900	FCC #1	FCC #1
LTE Band 17	FCC #1	FCC #1
LTE Band 5	FCC #1	FCC #1
LTE Band 4	FCC #1	FCC #1
LTE Band 2	FCC #1	FCC #1
2.4 GHz WLAN	FCC #1	FCC #1
5 GHz WLAN	FCC #1	FCC #1

## 1.9 LTE Information

LTE Information			
FCC ID	SS4EF500		
Form Factor	Enterprise Handheld Computer		
Frequency Range of each LTE transmission Band	LTE Band 17 (709 ~ 711 MHz)		
	LTE Band 5 (Cell) (829 ~ 844 MHz)		
	LTE Band 4 (AWS) (1715 ~ 1750 MHz)		
	LTE Band 2 (PCS) (1855 ~ 1905 MHz)		
Channel Bandwidths	LTE Band 17: 10 MHz		
	LTE Band 5 (Cell): 10 MHz		
	LTE Band 4 (AWS): 10 MHz		
	LTE Band 2 (PCS): 10 MHz		
Channel Number and Frequencies (MHz)	Low	Mid	High
LTE Band 17: 10 MHz	-	710(23790) <sup>Note1</sup>	-
LTE Band 5 (Cell): 10 MHz	-	836.5(20525) <sup>Note1</sup>	-
LTE Band 4 (AWS): 10 MHz	1715(20000)	1732.5(20175)	1750(20350)
LTE Band 2 (PCS): 10 MHz	1855(18650)	1880(18900)	1905(19150)
UE Category / Modulations Supported	UE Category 4 / QPSK, 16QAM		
LTE MPR Permanently implemented per 3GPP TS 36.101 section 6.2.3~6.2.5? (manufacturer attestation to be provided)	Yes		
A-MPR (Additional MPR) disabled for SAR Testing?	N/A (This device does not support A-MPR)		
LTE Carrier Aggregation	This device does not support both UL and DL carrier aggregation.		

Note 1: LTE Band 17 and LTE Band 5 (Cell) at 10 MHz bandwidth does not support three non-overlapping channels. Per KDB 941225 D05v02r04, when a device supports overlapping channel assignment in a channel bandwidth configuration, the middle channel of the group of overlapping channels should be selected for testing.

## 2. INTROCUCTION

The FCC and Industry Canada have adopted the guidelines for evaluating the environmental effects of radio frequency (RF) radiation in ET Docket 93-62 on Aug. 6, 1996 and Health Canada Safety Code 6 to protect the public and workers from the potential hazards of RF emissions due to FCC-regulated portable devices.

The FCC has adopted the guidelines for evaluating the environmental effects of radio frequency radiation in ET Docket 93-62 on Aug. 6, 1996 to protect the public and workers from the potential hazards of RF emissions due to FCC-regulated portable devices. The safety limits used for the environmental evaluation measurements are based on the criteria published by the American National Standards Institute (ANSI) for localized specific absorption rate (SAR) in IEEE/ANSI C95\*.1-2005 Standard for Safety Levels with Respect to Human Exposure to Radio Frequency Electromagnetic Fields, 3 kHz to 300 GHz. 1992 by the Institute of Electrical and Electronics Engineers, Inc., New York, New York 10017. The measurement procedure described in IEEE/ANSI C95.3-1992 Recommended Practice for the Measurement of Potentially Hazardous Electromagnetic Fields - RF and Microwave is used for guidance in measuring SAR due to the RF radiation exposure from the Equipment Under Test (EUT). These criteria for SAR evaluation are similar to those recommended by the National Council on Radiation Protection and Measurements (NCRP) in Biological Effects and Exposure Criteria for Radio frequency Electromagnetic Fields," NCRP Report No. 86 NCRP, 1986, Bethesda, MD 20814. SAR is a measure of the rate of energy absorption due to exposure to an RF transmitting source. SAR values have been related to threshold levels for potential biological hazards.

### SAR Definition

Specific Absorption Rate (SAR) is defined as the time derivative (rate) of the incremental energy (dU) absorbed by (dissipated in) an incremental mass (dm) contained in a volume element (dV) of a given density ( $\rho$ ) It is also defined as the rate of RF energy absorption per unit mass at a point in an absorbing body (see Fig. 2.1)

$$SAR = \frac{d}{dt} \left( \frac{dU}{dm} \right) = \frac{d}{dt} \left( \frac{dU}{\rho dv} \right)$$

Fig. 2.1 SAR Mathematical Equation

SAR is expressed in units of Watts per Kilogram (W/kg).

$$SAR = \frac{\sigma \cdot E^2}{\rho}$$

where:

- $\sigma$  = conductivity of the tissue-simulating material (S/m)
- $\rho$  = mass density of the tissue-simulating material (kg/m<sup>3</sup>)
- E = Total RMS electric field strength (V/m)

NOTE: The primary factors that control rate of energy absorption were found to be the wavelength of the incident field in relations to the dimensions and geometry of the irradiated organism, the orientation of the organism in relation to the polarity of field vectors, the presence of reflecting surfaces, and whether conductive contact is made by the organism with a ground plane.

### 3. DESCRIPTION OF TEST EQUIPMENT

#### 3.1 SAR MEASUREMENT SETUP

Measurements are performed using the DASY5 automated dosimetric assessment system. The DASY5 is made by Schmid & Partner Engineering AG (SPEAG) in Zurich, Switzerland and consists of high precision robotics system (Staubli), robot controller, desktop computer, near-field probe, probe alignment sensor, and the generic twin phantom containing the brain equivalent material. The robot is a six-axis industrial robot performing precise movements to position the probe to the location (points) of maximum electromagnetic field (EMF) (see Fig. 3.1).

A cell controller system contains the power supply, robot controller each pendant (Joystick), and a remote control used to drive the robot motors. The PC consists of the Intel Core i7-3770 3.40 GHz desktop computer with Windows 7 system and SAR Measurement Software DASY5, A/D interface card, monitor, mouse, and keyboard. The Staubli Robot is connected to the cell controller to allow software manipulation of the robot. A data acquisition electronic (DAE) circuit that performs the signal amplification, signal multiplexing, AD-conversion, offset measurements, mechanical surface detection, collision detection, etc. is connected to the Electro-optical coupler (EOC). The EOC performs the conversion from the optical into digital electric signal of the DAE and transfers data to the PC plug-in card.

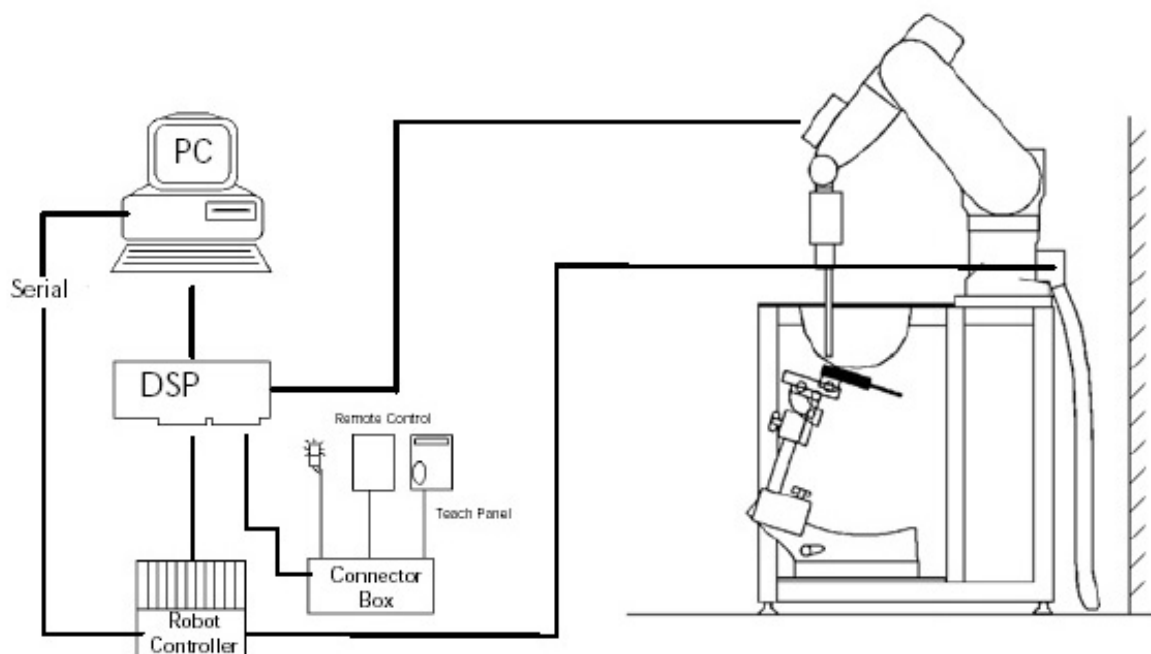

**Figure 3.1 SAR Measurement System Setup**

The DAE4 consists of a highly sensitive electrometer-grade preamplifier with auto-zeroing, a channel and gain-switching multiplexer, a fast 16 bit AD-converter and a command decoder and control logic unit. Transmission to the PC-card is accomplished through an optical downlink for data and status information and an optical uplink for commands and clock lines. The mechanical probe mounting device includes two different sensor systems for frontal and sidewise probe contacts. They are also used for mechanical surface detection and probe collision detection. The robot uses its own controller with a built in VME-bus computer. The system is described in detail.

### 3.2 EX3DV4Probe Specification

<b>Calibration</b>	In air from 10 MHz to 6 GHz In brain and muscle simulating tissue at Frequencies of 300 MHz, 450 MHz, 600 MHz, 750 MHz, 835 MHz, 900 MHz, 1750 MHz, 1900 MHz, 2300 MHz, 2450 MHz, 2600 MHz, 3500 MHz, 5200 MHz, 5300 MHz, 5500 MHz, 5600 MHz, 5800 MHz
<b>Frequency</b>	10 MHz to 6 GHz
<b>Linearity</b>	± 0.2 dB (30 MHz to 6 GHz)
<b>Dynamic</b>	10 μW/g to > 100 mW/g
<b>Range</b>	Linearity : ± 0.2 dB
<b>Dimensions</b>	Overall length : 337 mm
<b>Tip length</b>	20 mm
<b>Body diameter</b>	12 mm
<b>Tip diameter</b>	2.5 mm
<b>Distance from probe tip to sensor center</b>	1.0 mm
<b>Application</b>	SAR Dosimetry Testing Compliance tests of mobile phones

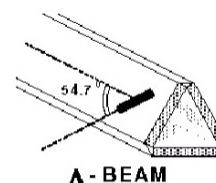
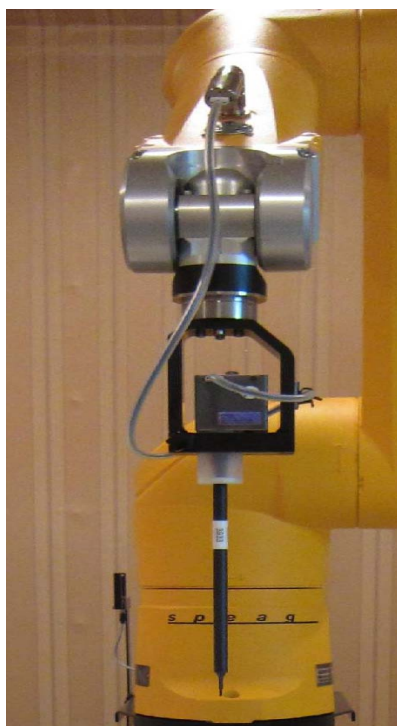

Figure 3.2 Triangular Probe Configurations



Figure 3.3 Probe Thick-Film Technique



DAE System

The SAR measurements were conducted with the dosimetric probe EX3DV4, designed in the classical triangular configuration(see Fig. 3.2) and optimized for dosimetric evaluation. The probe is constructed using the thick film technique; with printed resistive lines on ceramic substrates. The probe is equipped with an optical multitier line ending at the front of the probe tip. It is connected to the EOC box on the robot arm and provides an automatic detection of the phantom surface. Half of the fibers are connected to a pulsed infrared transmitter, the other half to a synchronized receiver. As the probe approaches the surface, the reflection from the surface produces a coupling from the transmitting to the receiving fibers. This reflection increases first during the approach, reaches maximum and then decreases. If the probe is flatly touching the surface, the coupling is zero. The distance of the coupling maximum to the surface is independent of the surface reflectivity and largely independent of the surface to probe angle. The DASY5 software reads the reflection during a software approach and looks for the maximum using a 2nd order fitting. The approach is stopped at reaching the maximum.



### 3.3 Probe Calibration Process

#### 3.3.1 E-Probe Calibration

##### Dosimetric Assessment Procedure

Each probe is calibrated according to a dosimetric assessment procedure with accuracy better than +/- 10%. The spherical isotropy was evaluated with the procedure and found to be better than +/-0.25dB. The sensitivity parameters (Norm X, Norm Y, Norm Z), the diode compression parameter (DCP) and the conversion factor (Conv F) of the probe is tested.

##### Free Space Assessment

The free space E-field from amplified probe outputs is determined in a test chamber. This is performed in a TEM cell for frequencies below 1 GHz, and in a waveguide above 1GHz for free space. For the free space calibration, the probe is placed in the volumetric center of the cavity at the proper orientation with the field. The probe is then rotated 360 degrees.

##### Temperature Assessment \*

E-field temperature correlation calibration is performed in a flat phantom filled with the appropriate simulated brain tissue. The measured free space E-field in the medium, correlates to temperature rise in a dielectric medium. For temperature correlation calibration a RF transparent the remits or based temperature probe is used in conjunction with the E-field probe.

$$SAR = C \frac{\Delta T}{\Delta t}$$

where:

$\Delta t$  = exposure time (30 seconds),

C = heat capacity of tissue (brain or muscle),

$\Delta T$  = temperature increase due to RF exposure.

$$SAR = \frac{|E|^2 \cdot \sigma}{\rho}$$

where:

$\sigma$  = simulated tissue conductivity,

$\rho$  = Tissue density (1.25 g/cm<sup>3</sup> for brain tissue)

SAR is proportional to  $\Delta T / \Delta t$ , the initial rate of tissue heating, before thermal diffusion takes place. Now it's possible to quantify the electric field in the simulated tissue by equating the thermally derived SAR to the E- field;

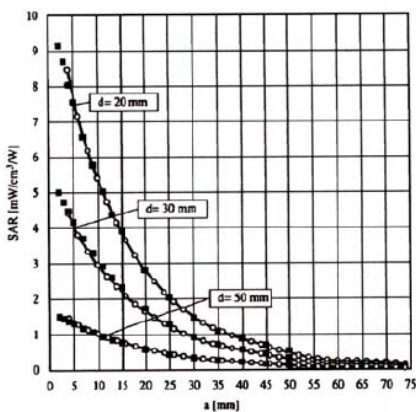

Figure 3.4 E-Field and Temperature Measurements at 900MHz

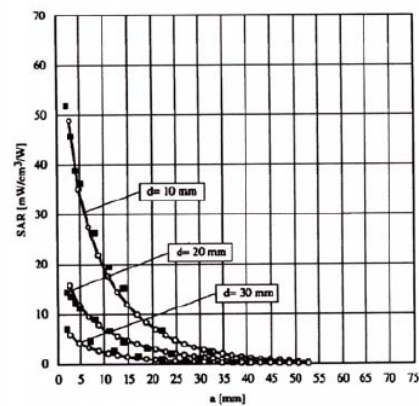

Figure 3.5 E-Field and Temperature Measurements at 1800MHz

### 3.4 Data Extrapolation

The DASY5 software automatically executes the following procedures to calculate the field units from the microvolt readings at the probe connector. The first step of the evaluation is a linearization of the filtered input signal to account for the compression characteristics of the detector diode. The compensation depends on the input signal, the diode type and the DC-transmission factor from the diode to the evaluation electronics. If the exciting field is pulsed, the crest factor of the signal must be known to correctly compensate for peak power. The formula for each channel can be given like below;

$$V_i = U_i + U_i^2 \cdot \frac{cf}{dcp_i}$$

with  $V_i$  = compensated signal of channel i (i=x,y,z)  
 $U_i$  = input signal of channel i (i=x,y,z)  
 $cf$  = crest factor of exciting field (DASY parameter)  
 $dcp_i$  = diode compression point (DASY parameter)

From the compensated input signals the primary field data for each channel can be evaluated:

E-field probes: with  $V_i$  = compensated signal of channel i (i = x,y,z)  
 $Norm_i$  = sensor sensitivity of channel i (i = x,y,z)  
 $\mu V/(V/m)^2$  for E-field probes  
 $ConvF$  = sensitivity of enhancement in solution  
 $E_i$  = electric field strength of channel i in V/m

$$E_i = \sqrt{\frac{V_i}{Norm_i \cdot ConvF}}$$

The RSS value of the field components gives the total field strength (Hermetian magnitude):

$$E_{tot} = \sqrt{E_x^2 + E_y^2 + E_z^2}$$

The primary field data are used to calculate the derived field units.

$$SAR = E_{tot}^2 \cdot \frac{\sigma}{\rho \cdot 1000}$$

with  $SAR$  = local specific absorption rate in W/g  
 $E_{tot}$  = total field strength in V/m  
 $\sigma$  = conductivity in [mho/m] or [Siemens/m]  
 $\rho$  = equivalent tissue density in g/cm<sup>3</sup>

The power flow density is calculated assuming the excitation field to be a free space field.

$$P_{free} = \frac{E_{tot}^2}{3770}$$

with  $P_{free}$  = equivalent power density of a plane wave in W/cm<sup>2</sup>  
 $E_{tot}$  = total electric field strength in V/m

### 3.5 SAM Twin PHANTOM

The SAM Twin Phantom V5.0 is constructed of a fiberglass shell integrated in a wooden table. The shape of the shell is based on data from an anatomical study designed to determine the maximum exposure in at least 90% of all users. It enables the dosimetric evaluation of left and right hand phone usage as well as body mounted usage at the flat phantom region. A cover prevents the evaporation of the liquid.

Reference markings on the Phantom allow the complete setup of all predefined phantom positions and measurement grids by manually teaching three points in the robot. (see Fig. 3.6)



Figure 3.6 SAM Twin Phantom

#### SAM Twin Phantom Specification:

<b>Construction</b>	The shell corresponds to the specifications of the Specific Anthropomorphic Mannequin (SAM) phantom defined in IEEE 1528 and IEC 62209-1. It enables the dosimetric evaluation of left and right hand phone usage as well as body mounted usage at the flat phantom region. A cover prevents evaporation of the liquid. Reference markings on the phantom allow the complete setup of all predefined phantom positions and measurement grids by teaching three points with the robot. Twin SAM V5.0 has the same shell geometry and is manufactured from the same material as Twin SAM V4.0, but has reinforced top structure.
<b>Shell Thickness</b>	$2 \pm 0.2$ mm
<b>Filling Volume</b>	Approx. 25 liters
<b>Dimensions</b>	Length: 1000 mm Width: 500 mm Height: adjustable feet

#### Specific Anthropomorphic Mannequin (SAM) Specifications:

The phantom for handset SAR assessment testing is a low-loss dielectric shell, with shape and dimensions derived from the anthropometric data of the 90th percentile adult male head dimensions as tabulated by the US Army. The SAM Twin Phantom shell is bisected along the mid-sagittal plane into right and left halves (see Fig. 3.7). The perimeter sidewalls of each phantom halves are extended to allow filling with liquid to a depth that is sufficient to minimized reflections from the upper surface. The liquid depth is maintained at a minimum depth of 15cm to minimize reflections from the upper surface.



Figure 3.7 Sam Twin Phantom shell

### 3.6 Modular Flat PHANTOM

#### Modular Flat Phantom Specification:

<b>Construction</b>	Triple Modular Phantom consists of three identical modules which can be installed and removed separately without emptying the liquid. It includes three reference points for phantom installation. Covers prevent evaporation of the liquid. Phantom material is resistant to DGBE based tissue simulating liquids. The MFP V5.1 will be delivered including wooden support only (non-standard SPEAG support). Applicable for system performance check from 800 MHz to 6 GHz and dosimetric evaluations for body-worn operation.	
<b>Shell Thickness</b>	2 ± 0.2 mm(bottom plate)	
<b>Filling Volume</b>	Approx. 9.2 liters(per module)	
<b>Dimensions</b>	Length: 830 mm Width: 500 mm	

### 3.7 Device Holder for Transmitters

In combination with the Twin SAM Phantom V4.0/V4.0c, V5.0 or ELI4, the Mounting Device enables the rotation of the mounted transmitter device in spherical coordinates. Rotation point is the ear opening point. Transmitter devices can be easily and accurately positioned according to IEC, IEEE, FCC or other specifications. The device holder can be locked for positioning at different phantom sections (left head, right head, flat).

Note: A simulating human hand is not used due to the complex anatomical and geometrical structure of the hand that may produce infinite number of configurations. To produce the worst-case condition (the hand absorbs antenna output power), the hand is omitted during the tests.



**Figure 3.8 Mounting Device**

### 3.8 Brain & Muscle Simulation Mixture Characterization

The brain and muscle mixtures consist of a viscous gel using hydrox-ethylcellulose (HEC) gelling agent and saline solution (see Table 3.1). Preservation with a bactericide is added and visual inspection is made to make sure air bubbles are not trapped during the mixing process. The mixture is calibrated to obtain proper dielectric constant (permittivity) and conductivity of the desired tissue. The mixture characterizations used for the brain and muscle tissue simulating liquids are according to the data by C. Gabriel and G. Harts grove.



Figure 3.9 Simulated Tissue

Table3.1 Composition of the Tissue Equivalent Matter

Ingredients (% by weight)	Frequency (MHz)							
	835		1900		2450		5200 ~ 5800	
Tissue Type	Head	Body	Head	Body	Head	Body	Head	Body
Water	40.19	50.75	55.24	70.23	71.88	73.40	65.52	80.00
Salt (NaCl)	1.480	0.940	0.310	0.290	0.160	0.060	-	-
Sugar	57.90	48.21	-	-	-	-	-	-
HEC	0.250	-	-	-	-	-	-	-
Bactericide	0.180	0.100	-	-	-	-	-	-
Triton X-100	-	-	-	-	19.97	-	17.24	-
DGBE	-	-	44.45	29.48	7.990	26.54	-	-
Diethylene glycol hexyl ether	-	-	-	-	-	-	17.24	-
Polysorbate (Tween) 80	-	-	-	-	-	-	-	20.00
Target for Dielectric Constant	41.5	55.2	40.0	53.3	39.2	52.7	-	-
Target for Conductivity (S/m)	0.90	0.97	1.40	1.52	1.80	1.95	-	-

- Salt: 99 % Pure Sodium Chloride                      Sugar: 98 % Pure Sucrose
- Water: De-ionized, 16M resistivity                      HEC: Hydroxyethyl Cellulose
- DGBE: 99 % Di(ethylene glycol) butyl ether,[2-(2-butoxyethoxy) ethanol]
- Triton X-100(ultra pure): Polyethylene glycol mono[4-(1,1,3,3-tetramethylbutyl)phenyl] ether

**Table3.2 HSL/MSL750 (Head and Body liquids for 700 – 800 MHz)**

Item	Head Tissue Simulation Liquids HSL750
	Muscle (body) Tissue Simulation Liquids MSL750
Type No	SL AAH 075, SL AAM 075
Manufacturer	SPEAG
The item is composed of the following ingredients:	
H <sup>2</sup> O	Water, 35 – 58%
Sucrose	Sucrose, 40 – 60%
NaCl	Sodium Chloride, 0 – 6%
Hydroxyethyl-cellulose	Medium Viscosity (CAS# 9004-62-0), < 0.3%
Preventol-D7	Preservative: aqueous preparation, (CAS# 55965-84-9), containing 5-chloro-2-methyl-3(2H)-isothiazolone and 2-methyl-3(2H)-isothiazolone, 0.1 – 0.6%

**Table3.3 HSL/MSL1750 (Head and Body liquids for 1700 – 1800 MHz)**

Item	Head Tissue Simulation Liquids HSL1750
	Muscle (body) Tissue Simulation Liquids MSL1750
Type No	SL AAH 175, SL AAM 175
Manufacturer	SPEAG
The item is composed of the following ingredients:	
H <sup>2</sup> O	Water, 52 – 75%
C8H18O3	Diethylene glycol monobutyl ether (DGBE), 25 – 48%
NaCl	Sodium Chloride, < 1.0%

### 3.9 SAR TEST EQUIPMENT

**Table 3.2 Test Equipment Calibration**

	Type	Manufacturer	Model	Cal.Date	Next.Cal.Date	S/N
<input checked="" type="checkbox"/>	SEMITEC Engineering	SEMITEC	N/A	N/A	N/A	Shield Room
<input checked="" type="checkbox"/>	Robot	SCHMID	TX60L	N/A	N/A	F14/5VR2A1/A/01
<input checked="" type="checkbox"/>	Robot Controller	SCHMID	CS8C	N/A	N/A	F14/5VR2A1/C/01
<input checked="" type="checkbox"/>	Joystick	SCHMID	N/A	N/A	N/A	D21142605A
<input checked="" type="checkbox"/>	IntelCorei7-3770 3.40 GHz Windows 7 Professional	N/A	N/A	N/A	N/A	N/A
<input checked="" type="checkbox"/>	Probe Alignment Unit LB	N/A	N/A	N/A	N/A	SE UKS 030 AA
<input checked="" type="checkbox"/>	Mounting Device	SCHMID	Holder	N/A	N/A	SD000H01KA
<input checked="" type="checkbox"/>	Twin SAM Phantom	SCHMID	QD000P40CD	N/A	N/A	TP1220
<input checked="" type="checkbox"/>	Triple Modular Phantom	SCHMID	QD000P51CA	N/A	N/A	1147
<input checked="" type="checkbox"/>	Data Acquisition Electronics	SCHMID	DAE4V1	2015-04-28	2016-04-28	1391
<input checked="" type="checkbox"/>	Dosimetric E-Field Probe	SCHMID	EX3DV4	2015-05-27	2016-05-27	3866
<input type="checkbox"/>	Dummy Probe	N/A	N/A	N/A	N/A	N/A
<input checked="" type="checkbox"/>	750 MHz SAR Dipole	SCHMID	D750V3	2014-11-13	2016-11-13	1049
<input checked="" type="checkbox"/>	835 MHz SAR Dipole	SCHMID	D835V2	2014-11-19	2016-11-19	4d159
<input checked="" type="checkbox"/>	1800 MHz SAR Dipole	SCHMID	D1800V2	2015-07-16	2017-07-16	2d047
<input checked="" type="checkbox"/>	1900 MHz SAR Dipole	SCHMID	D1900V2	2014-11-14	2016-11-14	5d176
<input checked="" type="checkbox"/>	2450 MHz SAR Dipole	SCHMID	D2450V2	2014-11-19	2016-11-19	920
<input checked="" type="checkbox"/>	5 GHz SAR Dipole	SCHMID	D5GHzV2	2015-03-23	2016-03-23	1103
<input checked="" type="checkbox"/>	Network Analyzer	Agilent	E5071C	2014-12-19	2015-12-19	MY46111534
<input checked="" type="checkbox"/>	Signal Generator	Agilent	ESG-3000A	2015-06-26	2016-06-26	US37230529
<input checked="" type="checkbox"/>	Signal Generator	Agilent	E4438C	2015-09-09	2016-09-09	US41461520
<input checked="" type="checkbox"/>	Amplifier	EMPOWER	BBS3Q7ELU	2015-09-09	2016-09-09	1020
<input checked="" type="checkbox"/>	Amplifier	RFBAY	MPA-40-40	2015-05-08	2016-05-08	21151801
<input checked="" type="checkbox"/>	Amplifier	EMPOWER	BBS3Q8CCJ	2015-10-20	2016-10-20	1005
<input checked="" type="checkbox"/>	Power Meter	HP	EPM-442A	2015-02-26	2016-02-26	GB37170267
<input checked="" type="checkbox"/>	Power Meter	Anritsu	ML2495A	2014-10-07	2015-10-07	1435003
				2015-09-23	2016-09-23	
<input checked="" type="checkbox"/>	Wide Bandwidth Power Sensor	Anritsu	MA2490A	2014-10-07	2015-10-07	1409034
				2015-09-23	2016-09-23	
<input checked="" type="checkbox"/>	Power Sensor	HP	8481A	2015-02-26	2016-02-26	3318A96566
<input checked="" type="checkbox"/>	Power Sensor	HP	8481A	2015-02-06	2016-02-06	2702A65976
<input checked="" type="checkbox"/>	Dual Directional Coupler	Agilent	778D-012	2015-01-06	2016-01-06	50228
<input checked="" type="checkbox"/>	Directional Coupler	HP	772D	2015-07-27	2016-07-27	2889A01064
<input checked="" type="checkbox"/>	Low Pass Filter 1.5 GHz	Micro LAB	LA-15N	2015-01-06	2016-01-06	N/A
<input checked="" type="checkbox"/>	Low Pass Filter 3.0 GHz	Micro LAB	LA-30N	2014-09-11	2015-09-11	N/A
				2015-09-09	2016-09-09	
<input checked="" type="checkbox"/>	Low Pass Filter 6.0 GHz	Micro LAB	LA-60N	2015-02-25	2016-02-25	N/A
<input checked="" type="checkbox"/>	Attenuators (3 dB)	Agilent	8491B	2015-06-26	2016-06-26	MY39260700
<input checked="" type="checkbox"/>	Attenuators (10 dB)	WEINSCHEL	23-10-34	2015-01-06	2016-01-06	BP4387
<input type="checkbox"/>	Step Attenuator	HP	8494A	2014-09-11	2015-09-11	3308A33341
				2015-09-10	2016-09-10	
<input checked="" type="checkbox"/>	Dielectric Probe kit	SCHMID	DAK-3.5	2014-12-09	2015-12-09	1092
<input checked="" type="checkbox"/>	8960 Series 10 Wireless Comms. Test Set	Agilent	E5515C	2014-09-12	2015-09-12	GB41321164
				2015-09-10	2016-09-10	
<input checked="" type="checkbox"/>	Wideband Radio Communication Tester	Rohde Schwarz	CMW500	2014-09-18	2015-09-18	101414
				2015-09-09	2016-09-09	
<input checked="" type="checkbox"/>	Power Splitter	Anritsu	K241B	2015-02-25	2016-02-25	1301184
<input checked="" type="checkbox"/>	Bluetooth Tester	TESCOM	TC-3000B	2015-01-06	2016-01-06	3000B770243

**NOTE:** The E-field probe was calibrated by SPEAG, by temperature measurement procedure. Dipole Verification measurement is performed by DT&C before each test. The brain and muscle simulating material are calibrated by DT&C using the dielectric probe system and network analyzer to determine the conductivity and permittivity (dielectric constant) of the brain-equivalent material. Each equipment item was used solely within its respective calibration period.

## 4. TEST SYSTEM SPECIFICATIONS

### Automated TEST SYSTEM SPECIFICATIONS:

#### Positioner

<b>Robot</b>	Stäubli Unimation Corp. Robot Model: TX60L
<b>Repeatability</b>	0.02 mm
<b>No. of axis</b>	6

#### Data Acquisition Electronic (DAE) System

##### Cell Controller

<b>Processor</b>	Intel Core i7-3770
<b>Clock Speed</b>	3.40 GHz
<b>Operating System</b>	Windows 7 Professional
<b>Data Card</b>	DASY5 PC-Board

##### Data Converter

<b>Features</b>	Signal, multiplexer, A/D converter. & control logic
<b>Software</b>	DASY5
<b>Connecting Lines</b>	Optical downlink for data and status info Optical uplink for commands and clock

##### PC Interface Card

<b>Function</b>	24 bit (64 MHz) DSP for real time processing Link to DAE 4 16 bit A/D converter for surface detection system serial link to robot direct emergency stop output for robot
-----------------	--

##### E-Field Probes

<b>Model</b>	EX3DV4 S/N: 3916
<b>Construction</b>	Triangular core fiber optic detection system
<b>Frequency</b>	10 MHz to 6 GHz
<b>Linearity</b>	$\pm 0.2$ dB (30 MHz to 6 GHz)

##### Phantom

<b>Phantom</b>	SAM Twin Phantom (V5.0)
<b>Shell Material</b>	Composite
<b>Thickness</b>	$2.0 \pm 0.2$ mm

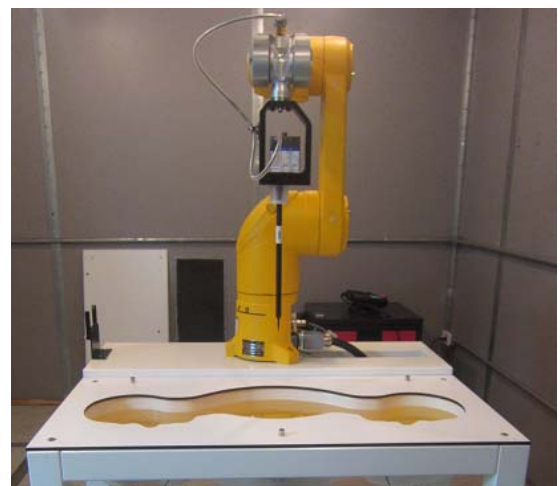

Figure 2.2 DASY5 Test System



## 5. SAR MEASUREMENT PROCEDURE

### 5.1 Measurement Procedure

The evaluation was performed using the following procedure compliant to FCC KDB Publication 865664 D01v01r04 and IEEE 1528-2013:

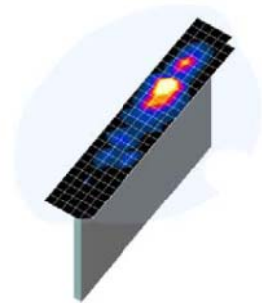

**Figure 5.1**  
Sample SAR Area Scan

1. The SAR distribution at the exposed side of the head or body was measured at a distance no greater than 5.0 mm from the inner surface of the shell. The area covered the entire dimension of the device-head and body interface and the horizontal grid resolution was determined per FCC KDB Publication 865664 D01v01r04 (See Table 5-1) and IEEE1528-2013.
2. The point SAR measurement was taken at the maximum SAR region determined from Step 1 to enable the monitoring of SAR fluctuations/drifts during the 1g/10g cube evaluation. SAR at this fixed point was measured and used as a reference value.
3. Based on the area scan data, the peak of the region with maximum SAR was determined by spline interpolation. Around this point, a volume was assessed according to the measurement resolution and volume size requirements of FCC KDB Publication 865664 D01v01r04 (See Table 5-1) and IEEE 1528-2013. On the basis of this data set, the spatial peak SAR value was evaluated with the following procedure (see references or the DASY manual online for more details):
  - a. SAR values at the inner surface of the phantom are extrapolated from the measured values along the line away from the surface with spacing no greater than that in Table 3-1. The extrapolation was based on a least-squares algorithm. A polynomial of the fourth order was calculated through the points in the z-axis (normal to the phantom shell).
  - b. After the maximum interpolated values were calculated between the points in the cube, the SAR was averaged over the spatial volume (1g or 10g) using a 3D-Spline interpolation algorithm. The 3D-spline is composed of three one-dimensional splines with the “Not a knot” condition (in x, y, and z directions). The volume was then integrated with the trapezoidal algorithm. One thousand points (10 x 10 x 10) were obtained through interpolation, in order to calculate the averaged SAR.
  - c. All neighboring volumes were evaluated until no neighboring volume with a higher average value was found.
4. The SAR reference value, at the same location as step 2, was re-measured after the zoom scan was complete to calculate the SAR drift. If the drift deviated by more than 5%, the SAR test and drift measurements were repeated.

Frequency	Maximum Area Scan Resolution (mm) ( $\Delta x_{area}, \Delta y_{area}$ )	Maximum Zoom Scan Resolution (mm) ( $\Delta x_{zoom}, \Delta y_{zoom}$ )	Maximum Zoom Scan Spatial Resolution (mm)			Minimum Zoom Scan Volume (mm) (x,y,z)
			Uniform Grid $\Delta z_{zoom}(n)$	Graded Grid		
				$\Delta z_{zoom}(1)^*$	$\Delta z_{zoom}(n>1)^*$	
≤ 2 GHz	≤ 15	≤ 8	≤ 5	≤ 4	$\leq 1.5 * \Delta z_{zoom}(n-1)$	≥ 30
2-3 GHz	≤ 12	≤ 5	≤ 5	≤ 4	$\leq 1.5 * \Delta z_{zoom}(n-1)$	≥ 30
3-4 GHz	≤ 12	≤ 5	≤ 4	≤ 3	$\leq 1.5 * \Delta z_{zoom}(n-1)$	≥ 28
4-5 GHz	≤ 10	≤ 4	≤ 3	≤ 2.5	$\leq 1.5 * \Delta z_{zoom}(n-1)$	≥ 25
5-6 GHz	≤ 10	≤ 4	≤ 2	≤ 2	$\leq 1.5 * \Delta z_{zoom}(n-1)$	≥ 22

**Table 5.1 Area and Zoom Scan Resolutions per FCC KDB Publication 865664 D01v01r04\***

\*Also compliant to IEEE 1528-2013 Table 6

## 6. DEFINITION OF REFERENCE POINTS

### 6.1 Ear Reference Point

Figure 6.1 shows the front, back and side views of the SAM Twin Phantom. The point “M” is the reference point for the center of the mouth, “LE” is the left ear reference point(ERP), and “RE” is the right ERP. The ERPs are 15mm posterior to the entrance to the Ear canal (EEC) along the B-M line (Back-Mouth), as shown in Figure 6.5. The plane Passing, through the two ear canals and M is defined as the Reference Plane. The line N-F (Neck- Front) is perpendicular to the reference plane and passing through the RE (or LE) is called the Reference Pivoting Line (see Figure 6.1). Line B-M is perpendicular to the N-F line. Both N-F and B-M lines are marked on the external phantom shell to facilitate handset positioning.

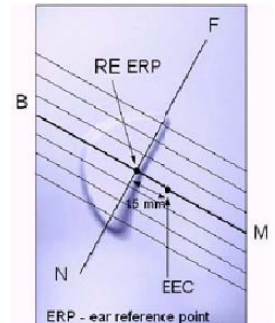

**Figure 6.1**  
Close-up side view of ERP

### 6.2 Handset Reference Points

Two imaginary lines on the handset were established: the vertical centerline and the horizontal line. The test device was placed in a normal operating position with the “test device reference point” located along the “vertical centerline” on the front of the device aligned to the “ear reference point” (See Fig. 6.3). The “test device reference point” was then located at the same level as the center of the ear reference point. The test device was positioned so that the “vertical centerline” was bisecting the front surface of the handset at it’s top and bottom edges, positioning the “ear reference point” on the outer surface of the both the left and right head phantoms on the ear reference point.



**Figure 6.2** Front, back and side view SAM Twin Phantom

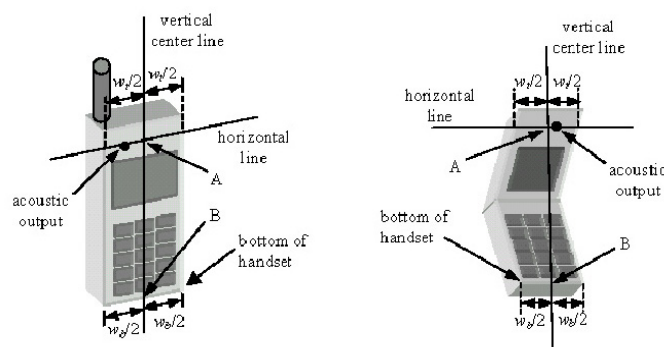

**Figure 6.3** Handset Vertical Center & Horizontal Line Reference Points

## 7. TEST CONFIGURATION POSITIONS FOR HANDSETS

### 7.1 Device Holder

The device holder is made out of low-loss POM material having the following dielectric parameters: relative permittivity  $\epsilon = 3$  and loss tangent  $\delta = 0.02$ .

### 7.2 Positioning for Cheek/Touch

1. The test device was positioned with the handset close to the surface of the phantom such that point A is on the (virtual) extension of the line passing through points RE and LE on the phantom (see Figure 7.1), such that the plane defined by the vertical center line and the horizontal line of the phone is approximately parallel to the sagittal plane of the phantom.

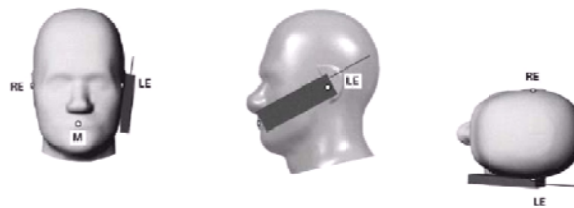

Figure 7.1 Front, Side and Top View of Cheek/Touch Position

2. The handset was translated towards the phantom along the line passing through RE & LE until the handset touches the ear.
3. While maintaining the handset in this plane, the handset was rotated around the LE-RE line until the vertical centerline was in the plane normal to MB-NF including the line MB (reference plane).
4. The phone was then rotated around the vertical centerline until the phone (horizontal line) was symmetrical with respect to the line NF.
5. While maintaining the vertical centerline in the reference plane, keeping point A on the line passing through RE and LE, and maintaining the phone contact with the ear, the handset was rotated about the line NF until any point on the handset made contact with a phantom point below the ear (cheek). (See Figure 7.2)

### 7.3 Positioning for Ear / 15 ° Tilt

With the test device aligned in the “Cheek/Touch Position”:

1. While maintaining the orientation of the phone, the phone was retracted parallel to the reference plane far enough to enable a rotation of the phone by 15 degree.
2. The phone was then rotated around the horizontal line by 15 degree.
3. While maintaining the orientation of the phone, the phone was moved parallel to the reference plane until any part of the phone touches the head. (In this position, point A was located on the line RE-LE). The tilted position is obtained when the contact is on the pinna. If the contact was at any location other than the pinna, the angle of the phone would then be reduced. The tilted position was obtained when any part of the phone was in contact of the ear as well as a second part of the phone was in contact with the head (see Figure 7.3).

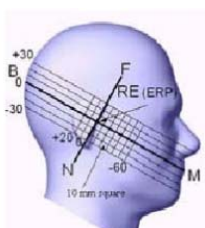

Figure 7.2 Side view w/relevant markings

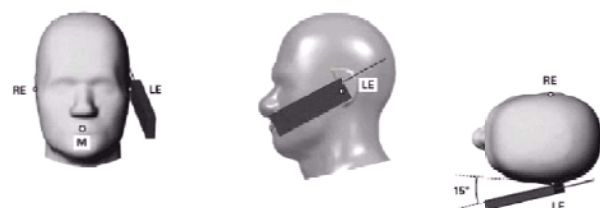

Figure 7.3 Front, Side and Top View of Ear/15° Position

## 7.4 Body-Worn Accessory Configurations

Body-worn operating configurations are tested with the belt-clips and holsters attached to the device and positioned against a flat phantom in a normal use configuration (see Figure 6.7). Per FCC KDB Publication 648474 D04v01r03, Body-worn accessory exposure is typically related to voice mode operations when handsets are carried in body-worn accessories. The body-worn accessory procedures in FCC KDB Publication 447498 D01v06 should be used to test for body-worn accessory SAR compliance, without a headset connected to it. This enables the test results for such configuration to be compatible with that required for hotspot mode when the body-worn accessory test separation distance is greater than or equal to that required for hotspot mode, when applicable. When the reported SAR for a body-worn accessory, measured without a headset connected to the handset, is  $> 1.2$  W/kg, the highest reported SAR configuration for that wireless mode and frequency band should be repeated for that body-worn accessory with a headset attached to the handset.

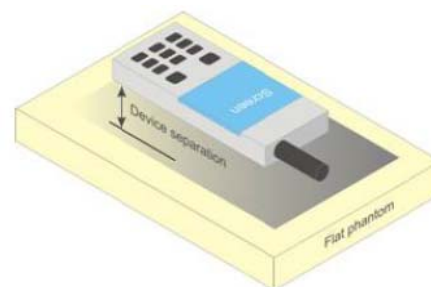

Figure 6.7 Sample Body-Worn Diagram

Accessories for Body-worn operation configurations are divided into two categories: those that do not contain metallic components and those that do contain metallic components. When multiple accessories that do not contain metallic components are supplied with the device, the device is tested with only the accessory that dictates the closest spacing to the body. Then multiple accessories that contain metallic components are tested with the device with each accessory. If multiple accessories share an identical metallic component (i.e. the same metallic belt-clip used with different holsters with no other metallic components) only the accessory that dictates the closest spacing to the body is tested.

Body-worn accessories may not always be supplied or available as options for some devices intended to be authorized for body-worn use. In this case, a test configuration with a separation distance between the back of the device and the flat phantom is used. Test position spacing was documented.

Transmitters that are designed to operate in front of a person's face, as in push-to-talk configurations, are tested for SAR compliance with the front of the device positioned to face the flat phantom in head fluid. For devices that are carried next to the body such as a shoulder, waist or chest-worn transmitters, SAR compliance is tested with the accessories, including headsets and microphones, attached to the device and positioned against a flat phantom in a normal use configuration.

## 7.5 Extremity Exposure Configurations

Devices that are designed or intended for use on extremities or mainly operated in extremity only exposure conditions; i.e., hands, wrists, feet and ankles, may require extremity SAR evaluation. When the device also operates in close proximity to the user's body, SAR compliance for the body is also required. The 1-g body and 10-g extremity SAR Exclusion Thresholds found in KDB Publication 447498 D01v06 should be applied to determine SAR test requirements.

Per KDB Publication 447498 D01v06, Cell phones (handsets) are not normally designed to be used on extremities or operated in extremity only exposure conditions. The maximum output power levels of handsets generally do not require extremity SAR testing to show compliance. Therefore, extremity SAR was not evaluated for this device.

## 7.6 Wireless Router Configurations

Some battery-operated handsets have the capability to transmit and receive user data through simultaneous transmission of WIFI simultaneously with a separate licensed transmitter. The FCC has provided guidance in FCC KDB Publication 941225 D06v02r01 where SAR test considerations for handsets ( $L \times W \geq 9 \text{ cm} \times 5 \text{ cm}$ ) are based on a composite test separation distance of 10 mm from the front, back and edges of the device containing transmitting antennas within 2.5 cm of their edges, determined from general mixed use conditions for this type of devices. Since the hotspot SAR results may overlap with the body-worn accessory SAR requirements, the more conservative configurations can be considered, thus excluding some body-worn accessory SAR tests.

When the user enables the personal wireless router functions for the handset, actual operations include simultaneous transmission of both the WIFI transmitter and another licensed transmitter. Both transmitters often do not transmit at the same transmitting frequency and thus cannot be evaluated for SAR under actual use conditions due to the limitations of the SAR assessment probes.

Therefore, SAR must be evaluated for each frequency transmission and mode separately and spatially summed with the WIFI transmitter according to FCC KDB Publication 447498 D01v06 publication procedures. The "Portable Hotspot" feature on the handset was NOT activated during SAR assessments, to ensure the SAR measurements were evaluated for a single transmission frequency RF signal at a time.

## 8. RF EXPOSURE LIMITS

### Uncontrolled Environment:

UNCONTROLLED ENVIRONMENTS are defined as locations where there is the exposure of individuals who have no knowledge or control of their exposure. The general population/uncontrolled exposure limits are applicable to situations in which the general public may be exposed or in which persons who are exposed as a consequence of their employment may not be made fully aware of the potential for exposure or cannot exercise control over their exposure. Members of the general public would come under this category when exposure is not employment-related; for example, in the case of a wireless transmitter that exposes persons in its vicinity.

### Controlled Environment:

CONTROLLED ENVIRONMENTS are defined as locations where there is exposure that may be incurred by persons who are aware of the potential for exposure, (i.e. as a result of employment or occupation). In general, occupational/controlled exposure limits are employment, who have been made fully aware of the potential for exposure and can exercise control over their exposure. This exposure category is also applicable when the exposure is of a transient nature due to incidental passage through a location where the exposure levels may be higher than the general population/uncontrolled limits, but the exposed person is fully aware of the potential for exposure and can exercise control over his or her exposure by leaving the area or by some other appropriate means.

**Table 8.1.SAR Human Exposure Specified in ANSI/IEEE C95.1-2005**

	HUMAN EXPOSURE LIMITS	
	General Public Exposure (W/kg) or (mW/g)	Occupational Exposure (W/kg) or (mW/g)
SPATIAL PEAK SAR * (Brain)	1.60	8.00
SPATIAL AVERAGE SAR ** (Whole Body)	0.08	0.40
SPATIAL PEAK SAR *** (Hands / Feet / Ankle / Wrist)	4.00	20.0

1. The Spatial Peak value of the SAR averaged over any 1 gram of tissue (defined as a tissue volume in the shape of a cube) and over the appropriate averaging time.
2. The Spatial Average value of the SAR averaged over the whole body.
3. The Spatial Peak value of the SAR averaged over any 10 grams of tissue (defined as a tissue volume in the shape of a cube) and over the appropriate averaging time.

Uncontrolled Environments are defined as locations where there is the exposure of individuals who have no knowledge or control of their exposure.

Controlled Environments are defined as locations where there is exposure that may be incurred by persons who are aware of the potential for exposure, (i.e.as a result of employment or occupation).

## 9. FCC MEASUREMENT PROCEDURES

Power measurements were performed using a base station simulator under digital average power.

### 9.1 Measured and Reported SAR

Per FCC KDB Publication 447498 D01v06, When SAR is not measured at the maximum power level allowed for production units, the results must be scaled to the maximum tune-up tolerance limit according to the power applied to the individual channels tested to determine compliance. For simultaneous transmission, the measured aggregate SAR must be scaled according to the sum of the differences between the maximum tune-up tolerance and actual power used to test each transmitter. When SAR is measured at or scaled to the maximum tune-up tolerance limit, the results are referred to as reported SAR. The highest reported SAR results are identified on the grant of equipment authorization according to procedures in KDB 690783 D01v01r03.

### 9.2 Procedures Used to Establish RF Signal for SAR

The following procedures are according to FCC KDB Publication 941225 D01 "SAR Measurement Procedures" v03r01, October 2015.

The device was placed into a simulated call using a base station simulator in a RF shielded chamber. Establishing connections in this manner ensure a consistent means for testing SAR and are recommended for evaluating SAR [4]. Devices under test were evaluated prior to testing, with a fully charged battery and were configured to operate at maximum output power. In order to verify that the device was tested throughout the SAR test at maximum output power, the SAR measurement system measures a "point SAR" at an arbitrary reference point at the start and end of the 1 gram SAR evaluation, to assess for any power drifts during the evaluation. If the power drift deviated by more than 5%, the SAR test and drift measurements were repeated.

### 9.3 SAR Measurement Conditions for CDMA2000

The following procedures were performed according to FCC KDB Publication 941225 D01 "3G SAR Procedures" v03r01, October 23, 2015.

#### 9.3.1 Output Power Verification

See 3GPP2 C.S0011/TIA-98-E as recommended by "SAR Measurement Procedures for 3G Devices" v02, October 2007. Maximum output power is verified on the High, Middle and Low channels according to procedures in section 4.4.5.2 of 3GPP2 C.S0011/TIA-98-E. SO55 tests were measured with power control bits in the "All Up" condition.

1. If the mobile station (MS) supports Reverse TCH RC 1 and Forward TCH RC 1, set up a call using Fundamental Channel Test Mode 1 (RC=1/1) with 9600 bps data rate only.
2. Under RC1, C.S0011 Table 4.4.5.2-1, Table 11-1 parameters were applied.
3. If the MS supports the RC 3 Reverse FCH, RC3 Reverse SCH0 and demodulation of RC 3, 4, or 5, set up a call using Supplemental Channel Test Mode 3 (RC 3/3) with 9600 bps Fundamental Channel and 9600 bps SCH0 data rate.
4. Under RC3, C.S0011 Table 4.4.5.2-2, Table 11-2 was applied.

#### Parameters for Max. Power for RC1

Parameter	Units	Value
$I_{or}$	dBm/1.23 MHz	-104
$\frac{Pilot E_c}{I_{or}}$	dB	-7
$\frac{Traffic E_c}{I_{or}}$	dB	-7.4

Table 11-1

#### Parameters for Max. Power for RC3

Parameter	Units	Value
$I_{or}$	dBm/1.23 MHz	-86
$\frac{Pilot E_c}{I_{or}}$	dB	-7
$\frac{Traffic E_c}{I_{or}}$	dB	-7.4

Table 11-2

5. FCHs were configured at full rate for maximum SAR with "All Up" power control bits.

### 9.3.2 CDMA 2000 1x Advanced

This device additionally supports 1x Advanced. Conducted powers were measured using SO75 with RC8 on the uplink and RC11 on the downlink per Oct 2012 TCB Workshop notes. Smart blanking was disabled for all measurements. The EUT was configured with forward power control Mode 000 and reverse power control at 400 bps. Conducted powers were measured on an Agilent 8960 Series 10 Wireless Communications Test Set, Model E5515C using the CDMA2000 1x Advanced application, Option E1962B-410.

Based on the maximum output power measured for 1x Advanced, SAR is required for 1x advanced when if the maximum output for 1x Advanced is more than 0.25 dB higher than the maximum measured for 1x. Also, if the measured SAR in any 1x mode exposure conditions (head, body etc.) is larger than 1.2 W/kg, the highest of those configurations above 1.2 W/kg for each exposure condition in 1x Advanced has to be repeated. All measured SAR in 1x mode higher than 1.5 W/kg must be repeated for 1x Advanced.

### 9.3.3 Head SAR Measurements

SAR for head exposure configurations is measured in RC3 with the DUT configured to transmit at full rate using Loopback Service Option SO55. SAR for RC1 is not required when the maximum average output of each channel is less than ¼ dB higher than that measured in RC3. Otherwise, SAR is measured on the maximum output channel in RC1 using the exposure configuration that results in the highest SAR for that channel in RC3.

### 9.3.4 Body SAR Measurements

SAR for body exposure configurations is measured in RC3 with the DUT configured to transmit at full rate on FCH with all other code channels disabled using TDSO / SO32. SAR for multiple code channels (FCH + SCHn) is not required when the maximum average output of each RF channel is less than ¼ dB higher than that measured with FCH only. Otherwise, SAR is measured on the maximum output channel (FCH + SCHn) with FCH at full rate and SCH0 enabled at 9600 bps using the exposure configuration that results in the highest SAR for that channel with FCH only. When multiple code channels are enabled, the DUT output may shift by more than 0.5 dB and lead to higher SAR drifts and SCH dropouts. Body SAR was measured using TDSO / SO32 with power control bits in the "All Up".

Body SAR in RC1 is not required when the maximum average output of each channel is less than ¼ dB higher than that measured in RC3. Otherwise, SAR is measured on the maximum output channel in RC1; with Loopback Service Option SO55, at full rate, using the body exposure configuration that results in the highest SAR for that channel in RC3.



## 9.4 SAR Measurement Conditions for WCDMA (UMTS)

### 9.4.1 Output Power Verification

Maximum output power is measured on the High, Middle and Low channels for each applicable transmission band according to the general descriptions in section 5.2 of 3GPP TS 34.121, using the appropriate RMC or AMR with TPC (transmit power control) set to all "1s".

Maximum output power is verified on the High, Middle and Low channels according to the general, descriptions in section 5.2 of 3GPP TS 34.121 (release 5), using the appropriate RMC with TPC,(transmit power control) set to all "1s" or applying the required inner loop power control procedures to maintain maximum output power while HSUPA is active. Results for all applicable physical channel configurations (DPCCH, DPDCHn and spreading codes, HS-DPCCH etc) are tabulated in this test report. All configurations that are not supported by the DUT or cannot be measured due to technical or equipment limitations are identified.

### 9.4.2 Head SAR Measurements for Handsets

SAR for head exposure configurations is measured using the 12.2 kbps RMC with TPC bits configured to all "1s". SAR in AMR configurations is not required when the maximum average output of each RF channel for 12.2 kbps AMR is less than 0.25 dB higher than that measured in 12.2 kbps RMC. Otherwise, SAR is measured on the maximum output channel in 12.2 AMR with a 3.4 kbps SRB (signaling radio bearer) using the exposure configuration that resulted in the highest SAR for that RF channel in the 12.2 kbps RMC mode.

### 9.4.3 Body SAR Measurements

SAR for body exposure configurations is measured using the 12.2 kbps RMC with the TPC bits all "1s".

### 9.4.4 Release 5 HSDPA Data Devices

The following procedures are applicable to HSDPA data devices operating under 3GPP Release 5. SAR is required for devices in body-worn accessory and other body exposure conditions, including handsets and data modems operating in various electronic devices. HSDPA operates in conjunction with WCDMA and requires an active DPCCH. The default test configuration is to measure SAR in WCDMA with HSDPA remain inactive, to establish a radio link between the test device and a communication test set using a 12.2 kbps RMC configured in Test Loop Mode 1. SAR for HSDPA is selectively measured using the highest reported SAR configuration in WCDMA, with an FRC in H-set 1 and a 12.2 kbps RMC. SAR is selectively confirmed for other physical channel configurations (DPCCH & DPDCHn) according to exposure conditions, device operating capabilities and maximum output power specified for production units, including tune-up tolerance by applying the 3G SAR test reduction procedures. Maximum output power is verified according to the applicable versions of 3GPP TS 34.121. SAR must be measured based on these maximum output conditions and requirements in KDB Publication 447498, with respect to the UE Categories, and explained in the SAR report. When Maximum Power Reduction (MPR) applies, the implementations must be clearly identified in the SAR report to support test results according to Cubic Metric (CM) and, as appropriate, Enhanced MPR (E-MPR) requirements.

Sub-test	$\beta_c$	$\beta_a$	$\beta_a$ (SF)	$\beta_c/\beta_a$	$\beta_{hs}^{(1)}$	CM (dB) <sup>(2)</sup>
1	2/15	15/15	64	2/15	4/15	0.0
2	12/15 <sup>(3)</sup>	15/15 <sup>(3)</sup>	64	12/15 <sup>(3)</sup>	24/15	1.0
3	15/15	8/15	64	15/8	30/15	1.5
4	15/15	4/15	64	15/4	30/15	1.5

Note 1:  $\Delta_{ACK}$ ,  $\Delta_{NACK}$  and  $\Delta_{CQI} = 8 \Leftrightarrow A_{hs} = \beta_{hs}/\beta_c = 30/15 \Leftrightarrow \beta_{hs} = 30/15 * \beta_c$   
 Note 2: CM = 1 for  $\beta_c/\beta_a = 12/15$ ,  $\beta_{hs}/\beta_c = 24/15$ .  
 Note 3: For subtest 2 the  $\beta_c/\beta_a$  ratio of 12/15 for the TFC during the measurement period (TF1, TF0) is achieved by setting the signaled gain factors for the reference TFC (TF1, TF1) to  $\beta_c = 11/15$  and  $\beta_a = 15/15$ .

Figure 9.1 Table 1

### 9.4.5 Release 6 HSUPA Data Devices

The following procedures are applicable to HSPA (HSUPA/HSDPA) data devices operating under 3GPP Release 6. SAR is required for devices in body-worn accessory and other body exposure conditions, including handsets and data modems operating in various electronic devices. HSUPA operates in conjunction with WCDMA and HSDPA. SAR is initially measured in WCDMA test configurations with HSPA remain inactive. The default test configuration is to establish a radio link between the test device and a communication test set to configure a 12.2 kbps RMC in Test Loop Mode 1. SAR for HSPA is selectively measured with HS-DPCCH, E-DPCCH and E-DPDCH, all enabled, along with a 12.2 kbps RMC using the highest reported SAR configuration in WCDMA with 12.2 kbps RMC only.

An FRC is configured according to HS-DPCCH Sub-test 1 using H-set 1 and QPSK. HSPA is configured according to E-DCH Sub-test 5 requirements. SAR for other HSPA sub-test configurations is confirmed selectively according to exposure conditions, E-DCH UE Category and maximum output power of production units, including tune-up tolerance by applying the 3G SAR test reduction procedure. Maximum output power is verified according to procedures in applicable versions of 3GPP TS 34.121. SAR must be measured based on these maximum output conditions and requirements in KDB Publication 447498, with respect to the UE Categories for HS-DPCCH and HSPA, and explained in the SAR report. When Maximum Power Reduction (MPR) applies, the implementations must be clearly identified in the SAR report to support test results according to Cubic Metric (CM) and, as appropriate, Enhanced MPR (E-MPR) requirements.

Sub-test	$\beta_c$	$\beta_a$	$\beta_a$ (SF)	$\beta_c/\beta_a$	$\beta_{hs}^{(1)}$	$\beta_{ec}$	$\beta_{ed}$	$\beta_{ed}$ (SF)	$\beta_{ed}$ (codes)	CM <sup>(2)</sup> (dB)	MPR (dB)	AG <sup>(4)</sup> Index	E- TFCI
1	11/15 <sup>(3)</sup>	15/15 <sup>(3)</sup>	64	11/15 <sup>(3)</sup>	22/15	209/225	1039/225	4	1	1.0	0.0	20	75
2	6/15	15/15	64	6/15	12/15	12/15	94/75	4	1	3.0	2.0	12	67
3	15/15	9/15	64	15/9	30/15	30/15	$\beta_{ed1}: 47/15$ $\beta_{ed2}: 47/15$	4	2	2.0	1.0	15	92
4	2/15	15/15	64	2/15	4/15	2/15	56/75	4	1	3.0	2.0	17	71
5	15/15 <sup>(4)</sup>	15/15 <sup>(4)</sup>	64	15/15 <sup>(4)</sup>	30/15	24/15	134/15	4	1	1.0	0.0	21	81

Note 1:  $\Delta_{ACK}$ ,  $\Delta_{NACK}$  and  $\Delta_{CQI} = 8 \Leftrightarrow A_{hs} = \beta_{hs}/\beta_c = 30/15 \Leftrightarrow \beta_{hs} = 30/15 * \beta_c$   
 Note 2: CM = 1 for  $\beta_c/\beta_a = 12/15$ ,  $\beta_{hs}/\beta_c = 24/15$ . For all other combinations of DPDCH, DPCCH, HS-DPCCH, E-DPDCH and E-DPCCH the MPR is based on the relative CM difference.  
 Note 3: For subtest 1 the  $\beta_c/\beta_a$  ratio of 11/15 for the TFC during the measurement period (TF1, TF0) is achieved by setting the signaled gain factors for the reference TFC (TF1, TF1) to  $\beta_c = 10/15$  and  $\beta_a = 15/15$ .  
 Note 4: For subtest 5 the  $\beta_c/\beta_a$  ratio of 15/15 for the TFC during the measurement period (TF1, TF0) is achieved by setting the signaled gain factors for the reference TFC (TF1, TF1) to  $\beta_c = 14/15$  and  $\beta_a = 15/15$ .  
 Note 5: Testing UE using E-DPDCH Physical Layer category 1 Sub-test 3 is not required according to TS 25.306 Table 5.1g.  
 Note 6:  $\beta_{ed}$  cannot be set directly; it is set by Absolute Grant Value.

Figure 9.2 Table 2

## 9.5 SAR Measurement Conditions for LTE

LTE modes were tested according to FCC KDB 941225 D05v02r04 publication. Please see notes after the tabulated SAR data for required test configurations. Establishing connections with base station simulators ensure a consistent means for testing SAR and are recommended for evaluating SAR. The R&S CMW500 was used for LTE output power measurement and SAR testing. Closed loop power control was used so the UE transmits with maximum output power during SAR testing. SAR tests were performed with the same number of RB and RB offsets transmitting on all TTI frames (maximum TTI).

### 9.5.1 Spectrum Plots for RB Configurations

A properly configured base station simulator was used for SAR tests and power measurements. Therefore, spectrum plots for RB configurations were not required to be included in this report.

### 9.5.2 MPR

MPR is permanently implemented for this device by the manufacturer. The specific manufacturer target MPR is indicated alongside the SAR results. MPR is enabled for this device, according to 3GPP TS36. 101 Section 6.2.3 – 6.2.5 under Table 6.2.3-1.

### 9.5.3 A-MPR

This device does not support the A-MPR.

### 9.5.4 Required RB Size and RB Offsets for SAR Testing

According to FCC KDB 941225 D05v02r04:

- a. Per Section 4.2.1, SAR is required for QPSK 1 RB Allocation for the largest bandwidth
  - i. The required channel and offset combination with the highest maximum output power is required for SAR.
  - ii. When the reported SAR is  $\leq 0.8$  W/kg, testing of the remaining RB offset configurations and required test channel is not required. Otherwise, SAR is required for the remaining required test channels using the RB offset configuration with highest output power for that channel.
  - iii. When the reported SAR for a required test channel is  $> 1.45$  W/kg, SAR is required for all RB offset configurations for that channel.
- b. Per Section 4.2.2, SAR is required for 50% RB allocation using the largest bandwidth following the same procedures outlined in Section 4.2.1.
- c. Per Section 4.2.3, QPSK SAR is not required for the 100% allocation when the highest maximum output power for the 100% allocation is less than the highest maximum output power of the 1 RB and 50% RB allocations and the reported SAR for the 1 RB and 50% RB allocations is  $< 0.8$  W/kg.
- d. Per Section 4.2.4 and 4.3, SAR tests for higher order modulations and lower bandwidths configurations are not required when the conducted power of the required test configurations determined by Sections 4.2.1 through 4.2.3 is less than or equal to 0.5 dB higher than the equivalent configuration using QPSK modulation and when the QPSK SAR for those configurations is  $< 1.45$  W/kg.

## 9.6 SAR Testing with 802.11 Transmitters

Normal network operating configurations are not suitable for measuring the SAR of 802.11 b/g/n transmitters. Unpredictable fluctuations in network traffic and antenna diversity conditions can introduce undesirable variations in SAR results. The SAR for these devices should be measured using chipset based test mode software to ensure the results are consistent and reliable. See KDB Publication 248227 D01v02r02 for more details.

### 9.6.1 General Device Setup

Chipset based test mode software is hardware dependent and generally varies among manufacturers. The device operating parameters established in test mode for SAR measurements must be identical to those programmed in production units, including output power levels, amplifier gain settings and other RF performance tuning parameters. The test frequencies should correspond to actual channel frequencies defined for domestic use. SAR for devices with switched diversity should be measured with only one antenna transmitting at a time during each SAR measurement, according to a fixed modulation and data rate. The same data pattern should be used for all measurements.

### 9.6.2 U-NII and U-NII-2A

For devices that operate in only one of the U-NII-1 and U-NII-2A bands, the normally required SAR procedures for OFDM configurations are applied. For devices that operate in both U-NII bands using the same transmitter and antenna(s), SAR test reduction is determined according to the following, with respect to the highest reported SAR and maximum output power specified for production units. The procedures are applied independently to each exposure configuration; for example, head, body, hotspot mode etc.

- 1) When the same maximum output power is specified for both bands, begin SAR measurement in U-NII-2A band by applying the OFDM SAR requirements. If the highest reported SAR for a test configuration is  $\leq 1.2$  W/kg, SAR is not required for U-NII-1 band for that configuration (802.11 mode and exposure condition); otherwise, each band is tested independently for SAR.
- 2) When different maximum output power is specified for the bands, begin SAR measurement in the band with higher specified maximum output power. The highest reported SAR for the tested configuration is adjusted by the ratio of lower to higher specified maximum output power for the two bands. When the adjusted SAR is  $\leq 1.2$  W/kg, SAR is not required for the band with lower maximum output power in that test configuration; otherwise, each band is tested independently for SAR.

### 9.6.3 U-NII-2C and U-NII-3

The frequency range covered by U-NII-2C and U-NII-3 is 380 MHz (5.47 – 5.85 GHz), which requires a minimum of at least two SAR probe calibration frequency points to support SAR measurements.

When Terminal Doppler Weather Rader (TDWR) restriction applies, the channels at 5.60 – 5.65 GHz in U-NII-2C band must be disabled with acceptable mechanisms and documented in the equipment certification.

Unless band gap channels are permanently disabled, SAR must be considered for these channels. When band gap channels are disabled, each band is tested independently according to the normally required OFDM SAR measurements and probe calibration frequency points requirements.

### 9.6.4 Initial Test Position Procedure

For exposure conditions with multiple test positions, such as handset operating next to the ear, devices with hotspot mode or UMPC mini-tablet, procedures for initial test position can be applied. Using the transmission mode determined by the DSSS procedure or initial test configuration, area scans are measured for all position in an exposure condition. The test position with the highest extrapolated (peak) SAR is used as the initial test position. When reported SAR for the initial test position is  $\leq 0.4$  W/kg, no additional testing for the remaining test positions is required. Otherwise, SAR is evaluated at the subsequent highest peak SAR position until the reported SAR result is  $\leq 0.8$  W/kg or all test position are measured.

### 9.6.5 2.4 GHz SAR Test Requirements

SAR is measured for 2.4 GHz 802.11b DSSS using either a fixed test position or, when applicable, the initial test position procedure. SAR test reduction is determined according to the following:

- 1) When the reported SAR of the highest measured maximum output power channel for the exposure configuration is  $\leq 0.8$  W/kg, no further SAR testing is required for 802.11b DSSS in that exposure configuration.
- 2) When the reported SAR is  $> 0.8$  W/kg, SAR is required for that exposure configuration using the next highest measured output power channel. When any reported SAR is  $> 1.2$  W/kg, SAR is required for the third channel; i.e., all channels require testing.

2.4 GHz 802.11 g/n OFDM are additionally evaluated for SAR if the highest reported SAR for 802.11b, adjusted by the ratio of the OFDM to DSSS specified maximum output power is  $> 1.2$  W/kg. When SAR is required for OFDM modes in 2.4 GHz band, the Initial Test Configuration Procedures should be followed.

### 9.6.6 OFDM Transmission Mode and SAR Test Channel Selection

For the 2.4 GHz and 5 GHz bands, when the same maximum output power was specified for multiple OFDM transmission mode configurations in a frequency band or aggregated band, SAR is measured using the configuration with the largest channel bandwidth, lowest order modulation and lowest data rate. When the maximum output power of a channel is the same for equivalent OFDM configurations; for example, 802.11a and 802.11n or 802.11g and 802.11n with the same channel bandwidth, modulation and data rate etc., the lower order 802.11 mode i.e., 802.11a, then 802.11g then 802.11n is used for SAR measurement. When the maximum output power were the same for multiple test channels, either according to the default or additional power measurement requirements, SAR is measured using the channel closest to the middle of the frequency band or aggregated band. When there are multiple channels with the same maximum output power, SAR is measured using the higher number channel.

### 9.6.7 Initial Test Configuration Procedure

For OFDM, in both 2.4 and 5 GHz bands, an initial test configuration is determined for each frequency band and aggregated band, according to the transmission mode with the highest maximum output power specified for SAR measurements. When the same maximum output is specified for multiple OFDM transmission mode configurations in a frequency band or aggregated band, SAR is measured using the configuration(s) with the largest channel bandwidth, lowest order modulation, and lowest data rate. The channel of the transmission mode with the highest average RF output conducted power will be the initial test configuration.

### 9.6.8 Subsequent Test Configuration Procedures

For OFDM configurations, in each frequency band and aggregated band, SAR is evaluated for initial test configuration using the fixed test position or the initial test position procedure, when applicable. When the highest reported SAR for the initial test configuration, adjusted by the ratio of the subsequent test configuration to initial test configuration specified maximum output power is  $\leq 1.2$  W/kg, no additional SAR testing for the subsequent test configurations is required.

## 10. RF CONDUCTED POWERS

### 10.1 CDMA Conducted Powers

Band	Channel	SO55	SO55	TDSO SO32 FCH	TDSO SO32 FCH+SCHn	1xEVDO Rev.0	1xEVDO Rev.0	1xEVDO Rev. A	1xEVDO Rev. A
		RC1	RC3	RC3	RC3	(FTAP)	(RTAP)	(FETAP)	(RETAP)
CDMA	1013	24.81	24.75	24.83	24.77	24.82	24.93	24.97	24.86
	384	24.60	24.48	24.51	24.52	24.51	24.58	24.58	24.55
	777	24.55	24.45	24.32	24.35	24.42	24.45	24.47	24.39
PCS	1013	24.03	23.95	23.93	23.94	23.91	23.98	24.04	23.96
	384	24.12	24.02	24.04	24.03	24.13	24.02	24.07	24.02
	777	23.71	23.67	23.85	23.84	23.75	24.01	23.87	23.89

Table 10.2 The power was measured by E5515C

Per KDB Publication 941225 D01v03r01:

1. Head SAR was tested with SO55 RC3. SO55 RC1 was not required since the average output power was not more than 0.25 dB than the SO55 RC3 powers.
2. Body-Worn SAR was tested with 1x RTT with TDSO / SO32 FCH Only. Ev-Do and TDSO / SO32 FCH+SCH SAR tests were not required since the average output power was not more than 0.25 dB higher than the TDSO / SO32 FCH only powers.

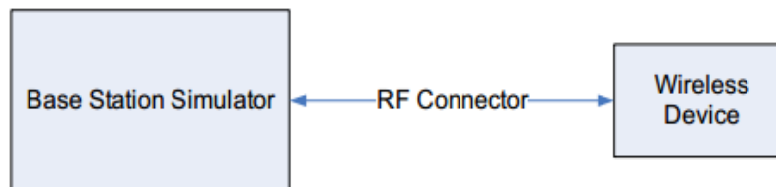

Figure 10.1 Power Measurement Setup

### 10.2 GSM Conducted Powers

Band	Channel	Maximum Burst-Averaged Output Power(dBm)								
		Voice	GPRS/EDGE Data (GMSK)				EDGE Data (8-PSK)			
		GSM CS 1 Slot	GPRS 1 TX Slot	GPRS 2 TX Slot	GPRS 3 TX Slot	GPRS 4 TX Slot	EDGE 1 TX Slot	EDGE 2 TX Slot	EDGE 3 TX Slot	EDGE 4 TX Slot
GSM850	128	33.02	33.02	31.20	29.44	28.61	27.10	26.85	26.43	25.97
	190	33.32	33.32	31.56	29.82	29.28	27.63	27.11	26.84	26.26
	251	33.41	33.41	31.68	29.83	29.23	27.14	26.92	26.78	26.06
GSM1900	512	29.75	29.75	28.35	27.08	26.02	25.96	25.57	24.92	24.36
	661	30.17	30.17	28.70	27.50	26.34	26.14	25.78	25.15	24.77
	810	29.90	29.90	28.75	27.35	26.38	25.42	25.06	24.84	23.97
Band	Channel	Calculated Maximum Frame-Averaged Output Power(dBm)								
		Voice	GPRS/EDGE Data (GMSK)				EDGE Data (8-PSK)			
		GSM CS 1 Slot	GPRS 1 TX Slot	GPRS 2 TX Slot	GPRS 3 TX Slot	GPRS 4 TX Slot	EDGE 1 TX Slot	EDGE 2 TX Slot	EDGE 3 TX Slot	EDGE 4 TX Slot
GSM850	128	23.99	23.99	25.18	25.18	<b>25.60</b>	18.07	20.83	22.17	22.96
	190	24.29	24.29	25.54	25.56	<b>26.27</b>	18.6	21.09	22.58	23.25
	251	24.38	24.38	25.66	25.57	<b>26.22</b>	18.11	20.9	22.52	23.05
GSM1900	512	20.72	20.72	22.33	22.82	<b>23.01</b>	16.93	19.55	20.66	21.35
	661	21.14	21.14	22.68	23.24	<b>23.33</b>	17.11	19.76	20.89	21.76
	810	20.87	20.87	22.73	23.09	<b>23.37</b>	16.39	19.04	20.58	20.96
<b>GSM850</b>	Frame Avg. Targets:	23.97	23.97	25.18	25.14	<b>25.79</b>	18.17	20.68	22.14	22.79
<b>GSM1900</b>		20.67	20.67	22.28	22.74	<b>22.89</b>	16.67	19.28	20.44	21.29

Table 10.1 The power was measured by E5515C

Note:

- Both burst-averaged and calculated frame-averaged powers are included. Frame-averaged power was calculated from the measured burst-averaged power by converting the slot powers into linear units and calculating the energy over 8 timeslots.
- The source-based frame-averaged output power was evaluated for all GPRS slot configurations. The configuration with the highest target frame averaged output power was evaluated for hotspot SAR. When the maximum frame-averaged powers are equivalent across two or more slots (within 0.25 dB), the configuration with the most number of time slots was tested.
- GPRS (GMSK) output powers were measured with coding scheme setting of 1 (CS1) on the base station simulator. CS1 was configured to measure GPRS output power measurements and SAR to ensure GMSK modulation in the signal. Our Investigation has shown that CS1 - CS4 settings do not have any impact on the output levels or modulation in the GPRS modes.
- EDGE (8-PSK) output powers were measured with MCS7 on the base station simulator. MCS7 coding scheme was used to measure the output powers for EDGE since investigation has shown that choosing MCS7 coding scheme will ensure 8-PSK modulation. It has been shown that MCS levels that produce 8PSK modulation do not have an impact on output power.

GPRS Multislot class: 12 (max 4 TX Uplink slots)  
 EDGE Multislot class: 12 (max 4 TX Uplink slots)  
 DTM Multislot Class: N/A



Figure 10.1 Power Measurement Setup

### 10.3 WCDMA Conducted Powers

3GPP Release Version	Mode	3GPP 34.121 Subtest	Cellular Band (dBm)			PCS Band (dBm)			3GPP MPR (dB)
			4132	4183	4233	9262	9400	9538	
99	WCDMA	12.2 kbps RMC	24.16	23.96	23.73	23.41	23.62	23.62	-
99		12.2 kbps AMR	24.09	23.94	23.71	23.35	23.55	23.58	-
5	HSDPA	Subtest 1	24.08	23.92	23.68	23.32	23.58	23.55	0
5		Subtest 2	24.04	23.86	23.71	23.28	23.49	23.51	0
5		Subtest 3	23.55	23.49	23.22	22.77	22.95	22.94	0.5
5		Subtest 4	23.52	23.44	23.18	22.75	22.93	22.92	0.5
6	HSUPA	Subtest 1	22.78	22.58	22.44	22.41	22.36	22.20	0
6		Subtest 2	22.16	21.89	21.66	21.13	21.00	21.55	2
6		Subtest 3	21.96	21.70	21.63	21.30	21.49	21.44	1
6		Subtest 4	22.50	22.33	22.23	21.97	22.06	21.95	2
6		Subtest 5	22.62	22.37	22.64	22.25	22.00	21.88	0

Table 10.2 The power was measured by E5515C

WCDMA SAR was tested under RMC 12.2 kbps with HSPA Inactive per KDB Publication 941225 D01v03r01. HSPA SAR was not required since the average output power of the HSPA subtests was not more than 0.25 dB higher than the RMC level and SAR was less than 1.2 W/kg.

The manufacturer declares that the HSUPA transmitter’s power will not exceed the R99 maximum transmit power in devices based on Qualcomm’s HSPA chipset solutions.

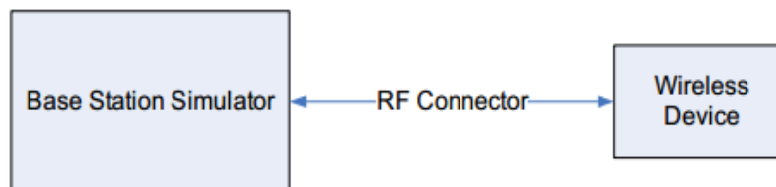

Figure 10.2 Power Measurement Setup



## 10.4 LTE Conducted Powers

### 1) LTE Band 17

Mode	Freq. (MHz)	Channel	LTE Band 17 Conducted Power– 10 MHz Bandwidth						
			Bandwidth (MHz)	Modulation	RB Size	RB Offset	Conducted Power(dBm)	MPR Allowed Per 3GPP(dB)	MPR (dB)
Mid	710	23790	10	QPSK	1	0	<b>23.87</b>	0	0
	710	23790	10	QPSK	1	25	23.77	0	0
	710	23790	10	QPSK	1	49	23.71	0	0
	710	23790	10	QPSK	25	0	<b>22.76</b>	0-1	1
	710	23790	10	QPSK	25	12	22.70	0-1	1
	710	23790	10	QPSK	25	25	22.73	0-1	1
	710	23790	10	QPSK	50	0	22.76	0-1	1
	710	23790	10	16QAM	1	0	22.92	0-1	1
	710	23790	10	16QAM	1	25	22.82	0-1	1
	710	23790	10	16QAM	1	49	22.84	0-1	1
	710	23790	10	16QAM	25	0	22.05	0-2	2
	710	23790	10	16QAM	25	12	22.04	0-2	2
	710	23790	10	16QAM	25	25	22.03	0-2	2
	710	23790	10	16QAM	50	0	22.02	0-2	2

Table 10.3.1 The power was measured by CMW500

### 2) LTE Band 5

Mode	Freq. (MHz)	Channel	LTE Band 5 Conducted Power– 10 MHz Bandwidth						
			Bandwidth (MHz)	Modulation	RB Size	RB Offset	Conducted Power(dBm)	MPR Allowed Per 3GPP(dB)	MPR (dB)
Mid	836.5	20525	10	QPSK	1	0	<b>23.88</b>	0	0
	836.5	20525	10	QPSK	1	25	23.87	0	0
	836.5	20525	10	QPSK	1	49	23.84	0	0
	836.5	20525	10	QPSK	25	0	<b>22.85</b>	0-1	1
	836.5	20525	10	QPSK	25	12	22.75	0-1	1
	836.5	20525	10	QPSK	25	25	22.81	0-1	1
	836.5	20525	10	QPSK	50	0	22.75	0-1	1
	836.5	20525	10	16QAM	1	0	22.92	0-1	1
	836.5	20525	10	16QAM	1	25	22.85	0-1	1
	836.5	20525	10	16QAM	1	49	22.91	0-1	1
	836.5	20525	10	16QAM	25	0	22.04	0-2	2
	836.5	20525	10	16QAM	25	12	22.06	0-2	2
	836.5	20525	10	16QAM	25	25	22.03	0-2	2
	836.5	20525	10	16QAM	50	0	22.04	0-2	2

Table 10.3.2 The power was measured by CMW500

### 3) LTE Band 4

Mode	Freq. (MHz)	Channel	LTE Band 4 (AWS) Conducted Power– 10 MHz Bandwidth						
			Bandwidth (MHz)	Modulation	RB Size	RB Offset	Conducted Power(dBm)	MPR Allowed Per 3GPP(dB)	MPR (dB)
Low	1715	20000	10	QPSK	1	0	22.85	0	0
	1715	20000	10	QPSK	1	25	22.88	0	0
	1715	20000	10	QPSK	1	49	22.73	0	0
	1715	20000	10	QPSK	25	0	21.87	0-1	1
	1715	20000	10	QPSK	25	12	21.92	0-1	1
	1715	20000	10	QPSK	25	25	21.91	0-1	1
	1715	20000	10	QPSK	50	0	21.95	0-1	1
	1715	20000	10	16QAM	1	0	21.90	0-1	1
	1715	20000	10	16QAM	1	25	21.82	0-1	1
	1715	20000	10	16QAM	1	49	21.97	0-1	1
	1715	20000	10	16QAM	25	0	21.10	0-2	2
	1715	20000	10	16QAM	25	12	21.11	0-2	2
	1715	20000	10	16QAM	25	25	21.14	0-2	2
Mid	1732.5	20175	10	QPSK	1	0	<b>22.90</b>	0	0
	1732.5	20175	10	QPSK	1	25	22.87	0	0
	1732.5	20175	10	QPSK	1	49	22.77	0	0
	1732.5	20175	10	QPSK	25	0	<b>22.00</b>	0-1	1
	1732.5	20175	10	QPSK	25	12	21.94	0-1	1
	1732.5	20175	10	QPSK	25	25	21.91	0-1	1
	1732.5	20175	10	QPSK	50	0	21.97	0-1	1
	1732.5	20175	10	16QAM	1	0	21.95	0-1	1
	1732.5	20175	10	16QAM	1	25	21.90	0-1	1
	1732.5	20175	10	16QAM	1	49	21.96	0-1	1
	1732.5	20175	10	16QAM	25	0	21.15	0-2	2
	1732.5	20175	10	16QAM	25	12	21.07	0-2	2
	1732.5	20175	10	16QAM	25	25	21.05	0-2	2
High	1750	20350	10	QPSK	1	0	22.76	0	0
	1750	20350	10	QPSK	1	25	22.77	0	0
	1750	20350	10	QPSK	1	49	22.79	0	0
	1750	20350	10	QPSK	25	0	21.97	0-1	1
	1750	20350	10	QPSK	25	12	21.73	0-1	1
	1750	20350	10	QPSK	25	25	21.78	0-1	1
	1750	20350	10	QPSK	50	0	21.83	0-1	1
	1750	20350	10	16QAM	1	0	21.94	0-1	1
	1750	20350	10	16QAM	1	25	21.97	0-1	1
	1750	20350	10	16QAM	1	49	21.94	0-1	1
	1750	20350	10	16QAM	25	0	21.13	0-2	2
	1750	20350	10	16QAM	25	12	21.04	0-2	2
	1750	20350	10	16QAM	25	25	21.02	0-2	2
1750	20350	10	16QAM	50	0	21.06	0-2	2	

Table 10.3.3The power was measured by CMW500

4) LTE Band 2

Mode	Freq. (MHz)	Channel	LTE Band 2 (PCS) Conducted Power- 10 MHz Bandwidth						
			Bandwidth (MHz)	Modulation	RB Size	RB Offset	Conducted Power(dBm)	MPR Allowed Per 3GPP(dB)	MPR (dB)
Low	1855	18650	10	QPSK	1	0	23.10	0	0
	1855	18650	10	QPSK	1	25	23.09	0	0
	1855	18650	10	QPSK	1	49	23.05	0	0
	1855	18650	10	QPSK	25	0	22.07	0-1	1
	1855	18650	10	QPSK	25	12	22.00	0-1	1
	1855	18650	10	QPSK	25	25	22.00	0-1	1
	1855	18650	10	QPSK	50	0	22.03	0-1	1
	1855	18650	10	16QAM	1	0	22.24	0-1	1
	1855	18650	10	16QAM	1	25	22.29	0-1	1
	1855	18650	10	16QAM	1	49	22.28	0-1	1
	1855	18650	10	16QAM	25	0	21.28	0-2	2
	1855	18650	10	16QAM	25	12	21.24	0-2	2
	1855	18650	10	16QAM	25	25	21.25	0-2	2
	1855	18650	10	16QAM	50	0	21.24	0-2	2
Mid	1880	18900	10	QPSK	1	0	<b>23.19</b>	0	0
	1880	18900	10	QPSK	1	25	23.09	0	0
	1880	18900	10	QPSK	1	49	23.02	0	0
	1880	18900	10	QPSK	25	0	<b>22.14</b>	0-1	1
	1880	18900	10	QPSK	25	12	22.09	0-1	1
	1880	18900	10	QPSK	25	25	22.07	0-1	1
	1880	18900	10	QPSK	50	0	22.06	0-1	1
	1880	18900	10	16QAM	1	0	22.28	0-1	1
	1880	18900	10	16QAM	1	25	22.29	0-1	1
	1880	18900	10	16QAM	1	49	22.27	0-1	1
	1880	18900	10	16QAM	25	0	21.26	0-2	2
	1880	18900	10	16QAM	25	12	21.22	0-2	2
	1880	18900	10	16QAM	25	25	21.33	0-2	2
	1880	18900	10	16QAM	50	0	21.22	0-2	2
High	1905	19150	10	QPSK	1	0	22.98	0	0
	1905	19150	10	QPSK	1	25	22.97	0	0
	1905	19150	10	QPSK	1	49	22.92	0	0
	1905	19150	10	QPSK	25	0	22.03	0-1	1
	1905	19150	10	QPSK	25	12	21.96	0-1	1
	1905	19150	10	QPSK	25	25	22.12	0-1	1
	1905	19150	10	QPSK	50	0	22.05	0-1	1
	1905	19150	10	16QAM	1	0	22.19	0-1	1
	1905	19150	10	16QAM	1	25	22.12	0-1	1
	1905	19150	10	16QAM	1	49	21.92	0-1	1
	1905	19150	10	16QAM	25	0	21.24	0-2	2
	1905	19150	10	16QAM	25	12	21.23	0-2	2
	1905	19150	10	16QAM	25	25	21.31	0-2	2
	1905	19150	10	16QAM	50	0	21.26	0-2	2

Table 10.3.4 The power was measured by CMW500

### 10.5 WLAN Conducted Powers

Mode	Freq.	Channel	802.11b (2.4 GHz) Conducted Power (dBm)			
			Data Rate (Mbps)			
	(MHz)	1	2	5.5	11	
802.11b	2412	1	16.26	16.21	16.12	16.02
	2437	6	16.28	16.23	16.14	16.04
	2462	11	<u>16.61</u>	16.56	16.47	16.37

Table 10.4.1 IEEE 802.11b Average RF Power

Mode	Freq.	Channel	802.11g (2.4 GHz) Conducted Power (dBm)							
			Data Rate (Mbps)							
	(MHz)	6	9	12	18	24	36	48	54	
802.11g	2412	1	13.15	13.08	12.96	13.03	12.82	12.74	12.66	12.69
	2437	6	13.23	13.20	13.06	13.11	12.97	12.93	12.86	12.88
	2462	11	11.58	11.54	11.39	11.43	11.36	11.30	11.25	11.26

Table 10.4.2 IEEE 802.11g Average RF Power

Mode	Freq.	Channel	802.11n HT20 (2.4 GHz) Conducted Power (dBm)							
			Data Rate (Mbps)							
	(MHz)	6.5	13	19.5	26	39	52	58.5	65	
802.11n (HT-20)	2412	1	11.16	11.04	10.83	10.88	10.77	10.74	10.80	10.67
	2437	6	11.22	11.10	10.89	10.94	10.83	10.80	10.86	10.73
	2462	11	11.59	11.47	11.26	11.31	11.20	11.17	11.23	11.10

Table 10.4.3 IEEE 802.11n HT20 Average RF Power

Mode	Freq.	Channel	802.11a (5 GHz) Conducted Power (dBm)							
			Data Rate (Mbps)							
	(MHz)	6	9	12	18	24	36	48	54	
802.11a	5180	36	10.49	10.44	10.43	10.45	10.40	10.37	10.35	10.31
	5200	40	10.37	10.32	10.31	10.33	10.28	10.25	10.23	10.19
	5220	44	10.34	10.29	10.28	10.30	10.25	10.22	10.20	10.16
	5240	48	10.84	10.79	10.78	10.80	10.75	10.72	10.70	10.66
	5260	52	<u>10.80</u>	10.75	10.74	10.76	10.71	10.68	10.66	10.62
	5280	56	10.67	10.62	10.61	10.63	10.58	10.55	10.53	10.49
	5300	60	10.52	10.47	10.46	10.48	10.43	10.40	10.38	10.34
	5320	64	10.43	10.38	10.37	10.39	10.34	10.31	10.29	10.25
	5500	100	10.19	10.14	10.13	10.15	10.10	10.07	10.05	10.01
	5580	116	<u>10.50</u>	10.45	10.44	10.46	10.41	10.38	10.36	10.32
	5660	132	10.14	10.09	10.08	10.10	10.05	10.02	10.00	9.96
	5720	144	10.44	10.39	10.38	10.40	10.35	10.32	10.30	10.26
	5745	149	<u>10.34</u>	10.29	10.28	10.30	10.25	10.22	10.20	10.16
	5785	157	10.20	10.15	10.14	10.16	10.11	10.08	10.06	10.02
	5825	165	10.02	9.97	9.96	9.98	9.93	9.90	9.88	9.84

Table 10.4.4 IEEE 802.11a Average RF Power

Mode	Freq.	Channel	802.11n HT20 (5 GHz) Conducted Power (dBm)							
			Data Rate (Mbps)							
	(MHz)	6.5	13	19.5	26	39	52	58.5	65	
802.11n (HT-20)	5180	36	10.67	10.62	10.61	10.63	10.58	10.55	10.53	10.49
	5200	40	10.58	10.53	10.52	10.54	10.49	10.46	10.44	10.40
	5220	44	10.48	10.43	10.42	10.44	10.39	10.36	10.34	10.30
	5240	48	10.95	10.90	10.89	10.91	10.86	10.83	10.81	10.77
	5260	52	10.84	10.79	10.78	10.80	10.75	10.72	10.70	10.66
	5280	56	10.95	10.90	10.89	10.91	10.86	10.83	10.81	10.77
	5300	60	10.56	10.51	10.50	10.52	10.47	10.44	10.42	10.38
	5320	64	10.48	10.43	10.42	10.44	10.39	10.36	10.34	10.30
	5500	100	10.25	10.20	10.19	10.21	10.16	10.13	10.11	10.07
	5580	116	10.57	10.52	10.51	10.53	10.48	10.45	10.43	10.39
	5660	132	10.16	10.11	10.10	10.12	10.07	10.04	10.02	9.98
	5720	144	10.50	10.45	10.44	10.46	10.41	10.38	10.36	10.32
	5745	149	10.37	10.32	10.31	10.33	10.28	10.25	10.23	10.19
	5785	157	10.24	10.19	10.18	10.20	10.15	10.12	10.10	10.06
5825	165	10.05	10.00	9.99	10.01	9.96	9.93	9.91	9.87	

Table 10.4.5 IEEE 802.11n HT20 Average RF Power

Mode	Freq.	Channel	802.11n HT40 (5 GHz) Conducted Power (dBm)							
			Data Rate (Mbps)							
	(MHz)	13.5	27	40.5	54	81	108	121.5	135	
802.11n (HT-40)	5190	38	10.69	10.64	10.63	10.65	10.60	10.57	10.55	10.51
	5230	46	10.48	10.43	10.42	10.44	10.39	10.36	10.34	10.30
	5270	54	10.84	10.79	10.78	10.80	10.75	10.72	10.70	10.66
	5310	62	10.66	10.61	10.60	10.62	10.57	10.54	10.52	10.48
	5510	102	10.25	10.20	10.19	10.21	10.16	10.13	10.11	10.07
	5550	110	10.00	9.95	9.94	9.96	9.91	9.88	9.86	9.82
	5670	134	10.02	9.97	9.96	9.98	9.93	9.90	9.88	9.84
	5710	142	9.77	9.72	9.71	9.73	9.68	9.65	9.63	9.61
	5755	151	10.26	10.21	10.20	10.22	10.17	10.14	10.12	10.08
	5795	159	10.06	10.01	10.00	10.02	9.97	9.94	9.92	9.88

Table 10.4.6 IEEE 802.11n HT40 Average RF Power

Justification for reduced test configurations for WIFI channels per KDB Publication 248227 D01v02r02 and October 2012 / April 2013 FCC/TCB Meeting Notes:

- Power measurements were performed for the transmission mode configuration with the highest maximum output power specified for production units.
- For transmission modes with the same maximum output power specification, powers were measured for the largest channel bandwidth, lowest order modulation and lowest data rate.
- For transmission modes with identical maximum specified output power, channel bandwidth, modulation and data rates, power measurements were required for all identical configurations.
- For each transmission mode configuration, powers were measured for the highest and lowest channels; and at the mid-band channel(s) when there were at least 3 channels supported. For configurations with multiple mid-band channels, duo to an even number of channels, both channels were measured.
- Output Power and SAR is not required for 802.11 g/n HT20 channels when the highest reported SAR for DSSS is adjusted by the ratio of OFDM to DSSS specified maximum output power and the adjust SAR is  $\leq 1.2$  W/kg.
- The underlined data rate and channel above were tested for SAR.

The average output powers of this device were tested by below configuration.

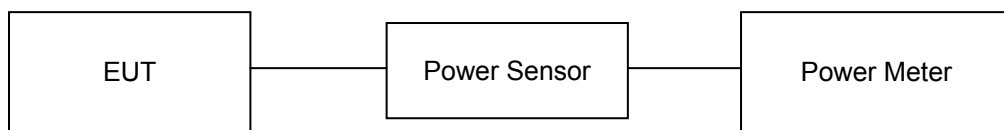

**Figure 10.1 Power Measurement Setup**

### 10.6 Bluetooth Conducted Powers

Channel	Frequency (MHz)	Frame AVG Output Power (1Mbps)		Frame AVG Output Power (2Mbps)		Frame AVG Output Power (3Mbps)	
		(dBm)	(mW)	(dBm)	(mW)	(dBm)	(mW)
Low	2402	5.76	3.767	3.34	2.158	3.36	2.168
Mid	2441	7.00	5.012	4.61	2.891	4.62	2.897
High	2480	5.47	3.524	3.07	2.028	3.10	2.042

Table 10.5.1 Bluetooth Frame Average RF Power

Channel	Frequency (MHz)	Frame AVG Output Power (LE)	
		(dBm)	(mW)
Low	2402	-3.84	0.413
Mid	2440	-3.03	0.498
High	2480	-4.39	0.364

Table 10.5.2 Bluetooth LE Frame Average RF Power

● **Bluetooth Conducted Powers procedures**

1. Bluetooth (BDR, EDR)

1) Enter DUT mode in EUT and operate it.

When it operating, The EUT is transmitting at maximum power level and duty cycle fixed.

2) Instruments and EUT were connected like Figure 10.4(A).

3) The maximum output powers of BDR(1 Mbps), EDR(2, 3 Mbps) and each frequency were set by a Bluetooth Tester.

4) Power levels were measured by a Power Meter.

2. Bluetooth (LE)

1) Enter LE mode in EUT and operate it.

When it operating, The EUT is transmitting at maximum power level and duty cycle fixed.

2) Instruments and EUT were connected like Figure 10.4(B).

3) The average conducted output powers of LE and each frequency can measurement according to setting program in EUT.

4) Power levels were measured by a Power Meter.

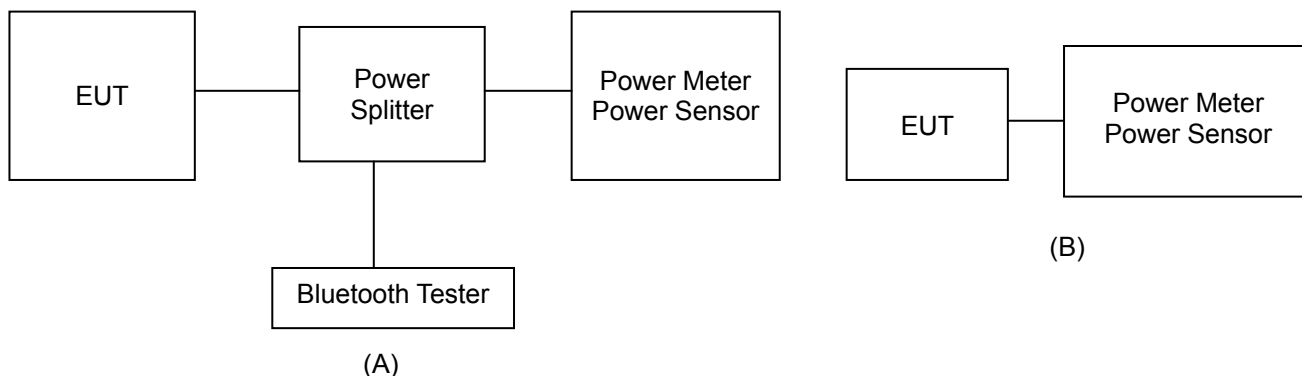

Figure 10.4 Average Power Measurement Setup

The average conducted output powers of Bluetooth were measured using above test setup and a wideband gated RF power meter when the EUT is transmitting at its maximum power level.



# 11. SYSTEM VERIFICATION

## 11.1 Tissue Verification

MEASURED TISSUE PARAMETERS										
Date(s)	Tissue Type	Ambient Temp.[°C]	Liquid Temp.[°C]	Measured Frequency [MHz]	Target Dielectric Constant, $\epsilon_r$	Target Conductivity, $\sigma$ (S/m)	Measured Dielectric Constant, $\epsilon_r$	Measured Conductivity, $\sigma$ (S/m)	Er Deviation [%]	$\sigma$ Deviation [%]
Aug. 28. 2015	835 Head	21.9	22.2	824.7	41.550	0.899	42.626	0.907	2.59	0.89
				835.0	41.500	0.900	42.529	0.916	2.48	1.78
				836.5	41.500	0.901	42.513	0.917	2.44	1.78
				848.3	41.500	0.914	42.403	0.928	2.18	1.53
Aug. 28. 2015	835 Body	21.9	22.2	824.7	55.240	0.969	54.781	0.987	-0.83	1.86
				835.0	55.200	0.970	54.696	0.996	-0.91	2.68
				836.5	55.200	0.971	54.681	0.997	-0.94	2.68
				848.3	55.160	0.986	54.575	1.006	-1.06	2.03
Sep. 02. 2015	1900 Head	22.0	22.4	1851.3	40.000	1.400	40.193	1.354	0.48	-3.29
				1880.0	40.000	1.400	40.134	1.384	0.34	-1.14
				1900.0	40.000	1.400	40.061	1.404	0.15	0.29
				1908.8	40.000	1.400	40.029	1.414	0.07	1.00
Sep. 02. 2015	1900 Body	22.0	22.4	1851.3	53.300	1.520	53.086	1.475	-0.40	-2.96
				1880.0	53.300	1.520	53.022	1.499	-0.52	-1.38
				1900.0	53.300	1.520	52.967	1.517	-0.62	-0.20
				1908.8	53.300	1.520	52.942	1.525	-0.67	0.33
Aug. 27. 2015	835 Head	22.2	22.5	824.2	41.550	0.899	42.317	0.909	1.85	1.11
				835.0	41.500	0.900	42.229	0.918	1.76	2.00
				836.6	41.500	0.901	42.211	0.920	1.71	2.11
				848.8	41.500	0.914	42.095	0.930	1.43	1.75
Aug. 27. 2015	835 Body	22.2	22.5	824.2	55.240	0.969	53.763	0.982	-2.67	1.34
				835.0	55.200	0.970	53.669	0.991	-2.77	2.16
				836.6	55.200	0.971	53.657	0.992	-2.80	2.16
				848.8	55.160	0.986	53.536	1.002	-2.94	1.62
Sep. 01. 2015	1900 Head	21.8	22.3	1850.2	40.000	1.400	40.117	1.371	0.29	-2.07
				1880.0	40.000	1.400	40.051	1.399	0.13	-0.07
				1900.0	40.000	1.400	39.984	1.419	-0.04	1.36
				1909.8	40.000	1.400	39.950	1.429	-0.12	2.07
Sep. 01. 2015	1900 Body	21.8	22.3	1850.2	53.300	1.520	52.301	1.483	-1.87	-2.43
				1880.0	53.300	1.520	52.218	1.511	-2.03	-0.59
				1900.0	53.300	1.520	52.158	1.530	-2.14	0.66
				1909.8	53.300	1.520	52.129	1.539	-2.20	1.25
Aug. 31. 2015	835 Head	22.4	22.7	826.4	41.540	0.899	42.697	0.917	2.79	2.00
				835.0	41.500	0.900	42.623	0.924	2.71	2.67
				836.6	41.500	0.901	42.605	0.926	2.66	2.77
				846.6	41.500	0.912	42.505	0.934	2.42	2.41
Aug. 31. 2015	835 Body	22.4	22.7	826.4	55.240	0.969	53.818	0.985	-2.57	1.65
				835.0	55.200	0.970	53.738	0.992	-2.65	2.27
				836.6	55.200	0.971	53.724	0.994	-2.67	2.37
				846.6	55.170	0.984	53.628	1.001	-2.79	1.73
Sep. 03. 2015	1900 Head	22.1	22.5	1852.4	40.000	1.400	40.316	1.375	0.79	-1.79
				1880.0	40.000	1.400	40.254	1.401	0.63	0.07
				1900.0	40.000	1.400	40.186	1.421	0.47	1.50
				1907.6	40.000	1.400	40.156	1.429	0.39	2.07
Sep. 03. 2015	1900 Body	22.1	22.5	1852.4	53.300	1.520	52.208	1.485	-2.05	-2.30
				1880.0	53.300	1.520	52.133	1.510	-2.19	-0.66
				1900.0	53.300	1.520	52.073	1.529	-2.30	0.59
				1907.6	53.300	1.520	52.048	1.536	-2.35	1.05
Sep. 09. 2015	750 Head	22.2	22.5	710.0	42.110	0.887	42.852	0.881	1.76	-0.68
				750.0	41.900	0.890	42.335	0.916	1.04	2.92
Sep. 09. 2015	750 Body	22.2	22.5	710.0	55.690	0.960	56.443	0.937	1.35	-2.40
				750.0	55.530	0.963	56.068	0.972	0.97	0.93





MEASURED TISSUE PARAMETERS										
Date(s)	Tissue Type	Ambient Temp.[°C]	Liquid Temp.[°C]	Measured Frequency [MHz]	Target Dielectric Constant, $\epsilon_r$	Target Conductivity, $\sigma$ (S/m)	Measured Dielectric Constant, $\epsilon_r$	Measured Conductivity, $\sigma$ (S/m)	Er Deviation [%]	$\sigma$ Deviation [%]
Sep. 08. 2015	835 Head	21.9	22.3	829.0	41.530	0.899	41.365	0.891	-0.40	-0.89
				835.0	41.500	0.900	41.338	0.897	-0.39	-0.33
				836.5	41.500	0.901	41.327	0.898	-0.42	-0.33
				844.0	41.500	0.910	41.285	0.906	-0.52	-0.44
Sep. 08. 2015	835 Body	21.9	22.3	829.0	55.220	0.970	54.857	0.992	-0.66	2.27
				835.0	55.200	0.970	54.804	0.997	-0.72	2.78
				836.5	55.200	0.971	54.789	0.998	-0.74	2.78
				844.0	55.170	0.981	54.721	1.004	-0.81	2.34
Sep. 07. 2015	1800 Head	22.3	22.6	1715.0	40.120	1.351	39.834	1.338	-0.71	-0.96
				1732.5	40.100	1.361	39.697	1.353	-1.00	-0.59
				1750.0	40.070	1.371	39.566	1.369	-1.26	-0.15
				1800.0	40.000	1.400	39.248	1.415	-1.88	1.07
Sep. 07. 2015	1800 Body	22.3	22.6	1715.0	53.590	1.466	53.641	1.474	0.10	0.55
				1732.5	53.560	1.477	53.606	1.488	0.09	0.74
				1750.0	53.520	1.488	53.572	1.504	0.10	1.08
				1800.0	53.300	1.520	53.444	1.550	0.27	1.97
Sep. 04. 2015	1900 Head	21.7	22.1	1855.0	40.000	1.400	39.461	1.380	-1.35	-1.43
				1880.0	40.000	1.400	39.372	1.403	-1.57	0.21
				1900.0	40.000	1.400	39.288	1.422	-1.78	1.57
				1905.0	40.000	1.400	39.267	1.427	-1.83	1.93
Sep. 04. 2015	1900 Body	21.7	22.1	1855.0	53.300	1.520	54.326	1.483	1.92	-2.43
				1880.0	53.300	1.520	54.279	1.504	1.84	-1.05
				1900.0	53.300	1.520	54.233	1.521	1.75	0.07
				1905.0	53.300	1.520	54.221	1.525	1.73	0.33
Sep. 10. 2015	2450 Head	22.5	22.8	2412.0	39.270	1.766	39.467	1.772	0.50	0.34
				2437.0	39.220	1.788	39.391	1.803	0.44	0.84
				2450.0	39.200	1.800	39.349	1.818	0.38	1.00
				2462.0	39.180	1.813	39.320	1.831	0.36	0.99
Sep. 10. 2015	2450 Body	22.5	22.8	2412.0	52.750	1.914	52.198	1.944	-1.05	1.57
				2437.0	52.720	1.938	52.141	1.974	-1.10	1.86
				2450.0	52.700	1.950	52.105	1.990	-1.13	2.05
				2462.0	52.680	1.967	52.081	2.004	-1.14	1.88
Dec. 4. 2015	5300 Head	21.4	21.8	5260.0	35.940	4.720	36.374	4.682	1.21	-0.81
				5280.0	35.920	4.740	36.343	4.709	1.18	-0.65
				5300.0	35.900	4.760	36.316	4.726	1.16	-0.71
				5320.0	35.880	4.780	36.267	4.752	1.08	-0.59
Dec. 5. 2015	5600 Head	21.6	21.9	5500.0	35.650	4.965	34.699	4.849	-2.67	-2.34
				5580.0	35.530	5.049	34.572	4.933	-2.70	-2.30
				5600.0	35.500	5.070	34.538	4.961	-2.71	-2.15
				5660.0	35.440	5.130	34.455	5.026	-2.78	-2.03
Dec. 5. 2015	5800 Head	21.6	21.9	5720.0	35.380	5.190	34.363	5.095	-2.87	-1.83
				5745.0	35.360	5.215	34.428	5.368	-2.64	2.93
				5785.0	35.320	5.255	34.363	5.415	-2.71	3.04
				5800.0	35.300	5.270	34.327	5.434	-2.76	3.11
				5825.0	35.280	5.296	34.292	5.469	-2.80	3.27

The above measured tissue parameters were used in the DASY software. The DASY software was used to perform interpolation to determine the dielectric parameters at the SAR test device frequencies (per KDB 865664 and IEEE 1528-2013 6.6.1.2). The tissue parameters listed in the SAR test plots may slightly differ from the table above due to significant digit rounding in the software.

**Measurement Procedure for Tissue verification:**

- 1) The network analyzer and probe system was configured and calibrated.
- 2) The probe was immersed in the sample which was placed in a nonmetallic container. Trapped air bubbles beneath the flange were minimized by placing the probe at a slight angle.
- 3) The complex admittance with respect to the probe aperture was measured
- 4) The complex relative permittivity, for example from the below equation (Pournaropoulos and Misra):

$$Y = \frac{j2\omega\epsilon_r\epsilon_0}{[\ln(b/a)]^2} \int_a^b \int_a^b \int_0^\pi \cos\phi' \frac{\exp[-j\omega r(\mu_0\epsilon_r\epsilon_0)^{1/2}]}{r} d\phi' d\rho' d\rho$$

where Y is the admittance of the probe in contact with the sample, the primed and unprimed coordinates refer to source and observation points, respectively,  $r^2 = \rho^2 + \rho'^2 - 2\rho\rho'\cos\phi'$ ,  $\omega$  is the angular frequency, and  $j = \sqrt{-1}$ .

## 11.2 Test System Verification

Prior to assessment, the system is verified to the  $\pm 10\%$  of the specifications at 835 MHz, 1800MHz, 1900 MHz, 2450 MHz and 5 GHz by using the SAR Dipole kit(s). (Graphic Plots Attached)

SYSTEM DIPOLE VERIFICATION TARGET & MEASURED												
SAR System #	Freq. [MHz]	SAR Dipole kits	Date(s)	Tissue Type	Ambient Temp.[°C]	Liquid Temp.[°C]	Probe S/N	Input Power (mW)	1 W Target SAR <sub>1g</sub> (W/kg)	Measured SAR <sub>1g</sub> (W/kg)	1 W Normalized SAR <sub>1g</sub> (W/kg)	Deviation [%]
B	835	D835V2, SN:4d159	Aug. 28. 2015	Head	21.9	22.2	3866	250	9.19	2.41	9.64	4.90
B	835	D835V2, SN: 4d159	Aug. 28. 2015	Body	21.9	22.2	3866	250	9.64	2.43	9.72	0.83
B	1900	D1900V2, SN:5d176	Sep. 02. 2015	Head	22.0	22.4	3866	250	40.1	10.00	40.00	-0.25
B	1900	D1900V2, SN: 5d176	Sep. 02. 2015	Body	22.0	22.4	3866	250	40.0	10.40	41.60	4.00
B	835	D835V2, SN:4d159	Aug. 27. 2015	Head	22.2	22.5	3866	250	9.19	2.46	9.84	7.07
B	835	D835V2, SN: 4d159	Aug. 27. 2015	Body	22.2	22.5	3866	250	9.64	2.42	9.68	0.41
B	1900	D1900V2, SN:5d176	Sep. 01. 2015	Head	21.8	22.3	3866	250	40.1	10.40	41.60	3.74
B	1900	D1900V2, SN: 5d176	Sep. 01. 2015	Body	21.8	22.3	3866	250	40.0	10.50	42.00	5.00
B	835	D835V2, SN:4d159	Aug. 31. 2015	Head	22.4	22.7	3866	250	9.19	2.48	9.92	7.94
B	835	D835V2, SN: 4d159	Aug. 31. 2015	Body	22.4	22.7	3866	250	9.64	2.41	9.64	0.00
B	1900	D1900V2, SN:5d176	Sep. 03. 2015	Head	22.1	22.5	3866	250	40.1	10.20	40.80	1.75
B	1900	D1900V2, SN: 5d176	Sep. 03. 2015	Body	22.1	22.5	3866	250	40.0	10.00	40.00	0.00
B	750	D750V2, SN: 1049	Sep. 09. 2015	Head	22.2	22.5	3866	250	8.22	2.09	8.36	1.70
B	750	D750V2, SN: 1049	Sep. 09. 2015	Body	22.2	22.5	3866	250	8.56	2.31	9.24	7.94
B	835	D835V2, SN: 4d159	Sep. 08. 2015	Head	21.9	22.3	3866	250	9.19	2.40	9.60	4.46
B	835	D835V2, SN: 4d159	Sep. 08. 2015	Body	21.9	22.3	3866	250	9.64	2.43	9.72	0.83
B	1800	D1800V2, SN: 2d047	Sep. 07. 2015	Head	22.3	22.6	3866	250	38.5	9.36	37.44	-2.75
B	1800	D1800V2, SN: 2d047	Sep. 07. 2015	Body	22.3	22.6	3866	250	37.2	9.76	39.04	4.95
B	1900	D1900V2, SN: 5d176	Sep. 04. 2015	Head	21.7	22.1	3866	250	40.1	10.50	42.00	4.74
B	1900	D1900V2, SN: 5d176	Sep. 04. 2015	Body	21.7	22.1	3866	250	40.0	10.30	41.20	3.00
B	2450	D2450V2, SN: 920	Sep. 10. 2015	Head	22.5	22.8	3866	250	52.7	13.10	52.40	-0.57
B	2450	D2450V2, SN: 920	Sep. 10. 2015	Body	22.5	22.8	3866	250	51.4	13.80	55.20	7.39
B	5300	D5GHzV2, SN: 1103	Dec. 4. 2015	Head	21.4	21.8	3866	100	82.4	8.21	82.10	-0.36
B	5600	D5GHzV2, SN: 1103	Dec. 5. 2015	Head	21.6	21.9	3866	100	82.2	8.46	84.60	2.92
B	5800	D5GHzV2, SN: 1103	Dec. 5. 2015	Head	21.6	21.9	3866	100	78.4	7.98	79.80	1.79

Note1 : System Verification was measured with input 250 mW , 100 mW(5200-5800 MHz) and normalized to 1W.

Note2 : To confirm the proper SAR liquid depth, the z-axis plots from the system verifications were included since the system verifications were performed using the same liquid, probe and DAE as the SAR tests in the same time period.

Note3: Full system validation status and results can be found in Attachment 3.

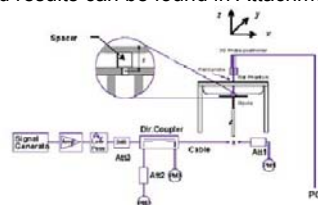

Figure 11.1 Dipole Verification Test Setup Diagram & Photo



## 12. SAR TEST RESULTS

### 12.1 Head SAR Results

Table 12.1 CDMA 850 Head SAR

MEASUREMENT RESULTS													
FREQUENCY		Mode/ Band	Service	Maximum Allowed Power [dBm]	Conducted Power [dBm]	Drift Power [dB]	Phantom Position	Device Serial Number	Duty Cycle	1g SAR (W/kg)	Scaling Factor	1g Scaled SAR (W/kg)	Plots #
MHz	Ch												
836.5	384	CDMA 850	SO55 RC3	25.0	24.48	0.050	Left Touch	FCC #1	1:1	0.167	1.127	0.188	
836.5	384	CDMA 850	SO55 RC3	25.0	24.48	0.150	Right Touch	FCC #1	1:1	0.196	1.127	0.221	A1
836.5	384	CDMA 850	SO55 RC3	25.0	24.48	-0.030	Left Tilt	FCC #1	1:1	0.0946	1.127	0.107	
836.5	384	CDMA 850	SO55 RC3	25.0	24.48	0.090	Right Tilt	FCC #1	1:1	0.0969	1.127	0.109	
ANSI / IEEE C95.1-2005- SAFETY LIMIT Spatial Peak Uncontrolled Exposure/General Population Exposure									Head 1.6 W/kg (mW/g) averaged over 1 gram				

Table 12.2 CDMA 1900 Head SAR

MEASUREMENT RESULTS													
FREQUENCY		Mode/ Band	Service	Maximum Allowed Power [dBm]	Conducted Power [dBm]	Drift Power [dB]	Phantom Position	Device Serial Number	Duty Cycle	1g SAR (W/kg)	Scaling Factor	1g Scaled SAR (W/kg)	Plots #
MHz	Ch												
1880.0	600	CDMA 1900	SO55 RC3	24.2	24.02	-0.020	Left Touch	FCC #1	1:1	0.099	1.042	0.103	A2
1880.0	600	CDMA 1900	SO55 RC3	24.2	24.02	0.140	Right Touch	FCC #1	1:1	0.0737	1.042	0.077	
1880.0	600	CDMA 1900	SO55 RC3	24.2	24.02	0.150	Left Tilt	FCC #1	1:1	0.0231	1.042	0.024	
1880.0	600	CDMA 1900	SO55 RC3	24.2	24.02	0.010	Right Tilt	FCC #1	1:1	0.0504	1.042	0.053	
ANSI / IEEE C95.1-2005- SAFETY LIMIT Spatial Peak Uncontrolled Exposure/General Population Exposure									Head 1.6 W/kg (mW/g) averaged over 1 gram				



Table 12.3 GSM/GPRS 850 Head SAR

MEASUREMENT RESULTS														
FREQUENCY		Mode/ Band	Service	Maximum Allowed Power [dBm]	Conducted Power [dBm]	Drift Power [dB]	Phantom Position	Device Serial Number	# of Time Slots	Duty Cycle	1g SAR (W/kg)	Scaling Factor	1g Scaled SAR (W/kg)	Plots #
MHz	Ch													
836.6	190	GSM850	GSM	33.5	33.32	0.180	Left Touch	FCC #1	1	1:8.3	0.116	1.042	0.121	
836.6	190	GSM850	GSM	33.5	33.32	0.140	Right Touch	FCC #1	1	1:8.3	0.130	1.042	0.135	
836.6	190	GSM850	GSM	33.5	33.32	0.140	Left Tilt	FCC #1	1	1:8.3	0.0668	1.042	0.070	
836.6	190	GSM850	GSM	33.5	33.32	0.080	Right Tilt	FCC #1	1	1:8.3	0.0759	1.042	0.079	
836.6	190	GSM850	GPRS	29.3	29.28	0.130	Left Touch	FCC #1	4	1:2.075	0.239	1.005	0.240	
836.6	190	GSM850	GPRS	33.5	33.32	0.060	Right Touch	FCC #1	1	1:8.3	0.133	1.042	0.139	
836.6	190	GSM850	GPRS	31.7	31.56	0.050	Right Touch	FCC #1	2	1:4.15	0.173	1.033	0.179	
836.6	190	GSM850	GPRS	29.9	29.82	0.080	Right Touch	FCC #1	3	1:2.77	0.212	1.019	0.216	
836.6	190	GSM850	GPRS	29.3	29.28	0.010	Right Touch	FCC #1	4	1:2.075	0.267	1.005	0.268	A3
836.6	190	GSM850	GPRS	29.3	29.28	0.120	Left Tilt	FCC #1	4	1:2.075	0.140	1.005	0.141	
836.6	190	GSM850	GPRS	29.3	29.28	0.040	Right Tilt	FCC #1	4	1:2.075	0.162	1.005	0.163	
ANSI / IEEE C95.1-2005– SAFETY LIMIT Spatial Peak Uncontrolled Exposure/General Population Exposure								Head 1.6 W/kg (mW/g) averaged over 1 gram						

Table 12.4 GSM/GPRS 1900 Head SAR

MEASUREMENT RESULTS														
FREQUENCY		Mode/ Band	Service	Maximum Allowed Power [dBm]	Conducted Power [dBm]	Drift Power [dB]	Phantom Position	Device Serial Number	# of Time Slots	Duty Cycle	1g SAR (W/kg)	Scaling Factor	1g Scaled SAR (W/kg)	Plots #
MHz	Ch													
1880.0	661	GSM1900	PCS	30.2	30.17	-0.010	Left Touch	FCC #1	1	1:8.3	0.0337	1.007	0.034	
1880.0	661	GSM1900	PCS	30.2	30.17	-0.130	Right Touch	FCC #1	1	1:8.3	0.0249	1.007	0.025	
1880.0	661	GSM1900	PCS	30.2	30.17	-0.120	Left Tilt	FCC #1	1	1:8.3	0.00621	1.007	0.006	
1880.0	661	GSM1900	PCS	30.2	30.17	-0.130	Right Tilt	FCC #1	1	1:8.3	0.00847	1.007	0.009	
1880.0	661	GSM1900	GPRS	30.2	30.17	0.180	Left Touch	FCC #1	1	1:8.3	0.0352	1.007	0.035	
1880.0	661	GSM1900	GPRS	28.8	28.70	-0.060	Left Touch	FCC #1	2	1:4.15	0.0548	1.023	0.056	
1880.0	661	GSM1900	GPRS	27.5	27.50	-0.170	Left Touch	FCC #1	3	1:2.77	0.0691	1.000	0.069	
1880.0	661	GSM1900	GPRS	26.4	26.34	0.040	Left Touch	FCC #1	4	1:2.075	0.075	1.014	0.076	A4
1880.0	661	GSM1900	GPRS	26.4	26.34	-0.100	Right Touch	FCC #1	4	1:2.075	0.0509	1.014	0.052	
1880.0	661	GSM1900	GPRS	26.4	26.34	-0.150	Left Tilt	FCC #1	4	1:2.075	0.0142	1.014	0.014	
1880.0	661	GSM1900	GPRS	26.4	26.34	0.190	Right Tilt	FCC #1	4	1:2.075	0.0214	1.014	0.022	
ANSI / IEEE C95.1-2005– SAFETY LIMIT Spatial Peak Uncontrolled Exposure/General Population Exposure								Head 1.6 W/kg (mW/g) averaged over 1 gram						



**Table 12.5 WCDMA 850 Head SAR**

MEASUREMENT RESULTS													
FREQUENCY		Mode/ Band	Service	Maximum Allowed Power [dBm]	Conducted Power [dBm]	Drift Power [dB]	Phantom Position	Device Serial Number	Duty Cycle	1g SAR (W/kg)	Scaling Factor	1g Scaled SAR (W/kg)	Plots #
MHz	Ch												
836.6	4183	WCDMA 850	RMC	24.2	23.96	0.070	Left Touch	FCC #1	1:1	0.150	1.057	0.159	
836.6	4183	WCDMA 850	RMC	24.2	23.96	0.110	Right Touch	FCC #1	1:1	0.183	1.057	0.193	A5
836.6	4183	WCDMA 850	RMC	24.2	23.96	0.130	Left Tilt	FCC #1	1:1	0.0916	1.057	0.097	
836.6	4183	WCDMA 850	RMC	24.2	23.96	-0.070	Right Tilt	FCC #1	1:1	0.0948	1.057	0.100	
ANSI / IEEE C95.1-2005– SAFETY LIMIT Spatial Peak Uncontrolled Exposure/General Population Exposure								Head 1.6 W/kg (mW/g) averaged over 1 gram					

**Table 12.6 WCDMA 1900 Head SAR**

MEASUREMENT RESULTS													
FREQUENCY		Mode/ Band	Service	Maximum Allowed Power [dBm]	Conducted Power [dBm]	Drift Power [dB]	Phantom Position	Device Serial Number	Duty Cycle	1g SAR (W/kg)	Scaling Factor	1g Scaled SAR (W/kg)	Plots #
MHz	Ch												
1880.0	9400	WCDMA 1900	RMC	23.7	23.62	0.140	Left Touch	FCC #1	1:1	0.068	1.019	0.069	A6
1880.0	9400	WCDMA 1900	RMC	23.7	23.62	-0.190	Right Touch	FCC #1	1:1	0.0474	1.019	0.048	
1880.0	9400	WCDMA 1900	RMC	23.7	23.62	0.110	Left Tilt	FCC #1	1:1	0.0151	1.019	0.015	
1880.0	9400	WCDMA 1900	RMC	23.7	23.62	0.034	Right Tilt	FCC #1	1:1	0.034	1.019	0.035	
ANSI / IEEE C95.1-2005– SAFETY LIMIT Spatial Peak Uncontrolled Exposure/General Population Exposure								Head 1.6 W/kg (mW/g) averaged over 1 gram					

**Table 12.7 LTE Band 17 Head SAR**

MEASUREMENT RESULTS																	
FREQUENCY		Mode/ Band	BW [MHz]	Max Allowed Power [dBm]	Cond. PWR [dBm]	Drift Power [dB]	MPR	Position	Device Serial Number	Mod.	RB Size	RB Offs.	Duty Cycle	1g SAR (W/kg)	Scaling Factor	1g Scaled SAR (W/kg)	Plots #
MHz	Ch																
710.0	23790	LTE B17	10	24.0	23.87	0.110	0	Left Touch	FCC #1	QPSK	1	0	1:1	0.100	1.030	0.103	
710.0	23790	LTE B17	10	23.0	22.76	0.020	1	Left Touch	FCC #1	QPSK	25	0	1:1	0.0771	1.057	0.081	
710.0	23790	LTE B17	10	24.0	23.87	0.020	0	Right Touch	FCC #1	QPSK	1	0	1:1	0.101	1.030	0.104	A7
710.0	23790	LTE B17	10	23.0	22.76	-0.010	1	Right Touch	FCC #1	QPSK	25	0	1:1	0.0818	1.057	0.086	
710.0	23790	LTE B17	10	24.0	23.87	0.110	0	Left Tilt	FCC #1	QPSK	1	0	1:1	0.0572	1.030	0.059	
710.0	23790	LTE B17	10	23.0	22.76	-0.100	1	Left Tilt	FCC #1	QPSK	25	0	1:1	0.045	1.057	0.048	
710.0	23790	LTE B17	10	24.0	23.87	0.090	0	Right Tilt	FCC #1	QPSK	1	0	1:1	0.0588	1.030	0.061	
710.0	23790	LTE B17	10	23.0	22.76	0.150	1	Right Tilt	FCC #1	QPSK	25	0	1:1	0.0438	1.057	0.046	
ANSI / IEEE C95.1-2005– SAFETY LIMIT Spatial Peak Uncontrolled Exposure/General Population Exposure									Head 1.6 W/kg (mW/g) averaged over 1 gram								



**Table 12.8 LTE Band 5 (Cell) Head SAR**

MEASUREMENT RESULTS																	
FREQUENCY		Mode/ Band	BW [MHz]	Max Allowed Power [dBm]	Cond. PWR [dBm]	Drift Power [dB]	MPR	Position	Device Serial Number	Mod.	RB Size	RB Offs.	Duty Cycle	1g SAR (W/kg)	Scaling Factor	1g Scaled SAR (W/kg)	Plots #
MHz	Ch																
836.5	20525	LTE B5	10	24.0	23.88	0.130	0	Left Touch	FCC #1	QPSK	1	0	1:1	0.112	1.028	0.115	
836.5	20525	LTE B5	10	23.0	22.85	0.170	1	Left Touch	FCC #1	QPSK	25	0	1:1	0.0848	1.035	0.088	
836.5	20525	LTE B5	10	24.0	23.88	0.120	0	Right Touch	FCC #1	QPSK	1	0	1:1	0.123	1.028	0.126	A8
836.5	20525	LTE B5	10	23.0	22.85	0.150	1	Right Touch	FCC #1	QPSK	25	0	1:1	0.091	1.035	0.094	
836.5	20525	LTE B5	10	24.0	23.88	-0.110	0	Left Tilt	FCC #1	QPSK	1	0	1:1	0.0663	1.028	0.068	
836.5	20525	LTE B5	10	23.0	22.85	-0.050	1	Left Tilt	FCC #1	QPSK	25	0	1:1	0.0511	1.035	0.053	
836.5	20525	LTE B5	10	24.0	23.88	0.070	0	Right Tilt	FCC #1	QPSK	1	0	1:1	0.055	1.028	0.057	
836.5	20525	LTE B5	10	23.0	22.85	-0.090	1	Right Tilt	FCC #1	QPSK	25	0	1:1	0.0428	1.035	0.044	
ANSI / IEEE C95.1-2005– SAFETY LIMIT Spatial Peak Uncontrolled Exposure/General Population Exposure										Head 1.6 W/kg (mW/g) averaged over 1 gram							

**Table 12.9 LTE Band 4 (AWS) Head SAR**

MEASUREMENT RESULTS																	
FREQUENCY		Mode/ Band	BW [MHz]	Max Allowed Power [dBm]	Cond. PWR [dBm]	Drift Power [dB]	MPR	Position	Device Serial Number	Mod.	RB Size	RB Offs.	Duty Cycle	1g SAR (W/kg)	Scaling Factor	1g Scaled SAR (W/kg)	Plots #
MHz	Ch																
1732.5	20175	LTE B4	10	23.0	22.90	0.000	0	Left Touch	FCC #1	QPSK	1	0	1:1	0.023	1.023	0.024	A9
1732.5	20175	LTE B4	10	22.0	22.00	0.000	1	Left Touch	FCC #1	QPSK	25	0	1:1	0.0195	1.000	0.020	
1732.5	20175	LTE B4	10	23.0	22.90	0.120	0	Right Touch	FCC #1	QPSK	1	0	1:1	0.00932	1.023	0.010	
1732.5	20175	LTE B4	10	22.0	22.00	0.050	1	Right Touch	FCC #1	QPSK	25	0	1:1	0.00784	1.000	0.008	
1732.5	20175	LTE B4	10	23.0	22.90	0.000	0	Left Tilt	FCC #1	QPSK	1	0	1:1	0.00663	1.023	0.007	
1732.5	20175	LTE B4	10	22.0	22.00	0.000	1	Left Tilt	FCC #1	QPSK	25	0	1:1	0.00548	1.000	0.005	
1732.5	20175	LTE B4	10	23.0	22.90	0.140	0	Right Tilt	FCC #1	QPSK	1	0	1:1	0.0101	1.023	0.010	
1732.5	20175	LTE B4	10	22.0	22.00	0.090	1	Right Tilt	FCC #1	QPSK	25	0	1:1	0.00758	1.000	0.008	
ANSI / IEEE C95.1-2005– SAFETY LIMIT Spatial Peak Uncontrolled Exposure/General Population Exposure										Head 1.6 W/kg (mW/g) averaged over 1 gram							



**Table 12.10 LTE Band 2 (PCS) Head SAR**

MEASUREMENT RESULTS																	
FREQUENCY		Mode/ Band	BW [MHz]	Max Allowed Power [dBm]	Cond. PWR [dBm]	Drift Power [dB]	MPR	Position	Device Serial Number	Mod.	RB Size	RB Offs.	Duty Cycle	1g SAR (W/kg)	Scaling Factor	1g Scaled SAR (W/kg)	Plots #
MHz	Ch																
1880.0	18900	LTE B2	10	23.2	23.19	-0.030	0	Left Touch	FCC #1	QPSK	1	0	1:1	0.101	1.002	0.101	A10
1880.0	18900	LTE B2	10	22.2	22.14	0.060	1	Left Touch	FCC #1	QPSK	25	0	1:1	0.0685	1.014	0.069	
1880.0	18900	LTE B2	10	23.2	23.19	-0.150	0	Right Touch	FCC #1	QPSK	1	0	1:1	0.0544	1.002	0.055	
1880.0	18900	LTE B2	10	22.2	22.14	-0.110	1	Right Touch	FCC #1	QPSK	25	0	1:1	0.0435	1.014	0.044	
1880.0	18900	LTE B2	10	23.2	23.19	-0.170	0	Left Tilt	FCC #1	QPSK	1	0	1:1	0.0231	1.002	0.023	
1880.0	18900	LTE B2	10	22.2	22.14	0.100	1	Left Tilt	FCC #1	QPSK	25	0	1:1	0.0176	1.014	0.018	
1880.0	18900	LTE B2	10	23.2	23.19	-0.110	0	Right Tilt	FCC #1	QPSK	1	0	1:1	0.0371	1.002	0.037	
1880.0	18900	LTE B2	10	22.2	22.14	0.000	1	Right Tilt	FCC #1	QPSK	25	0	1:1	0.031	1.014	0.031	
ANSI / IEEE C95.1-2005– SAFETY LIMIT Spatial Peak Uncontrolled Exposure/General Population Exposure										Head 1.6 W/kg (mW/g) averaged over 1 gram							

**Table 12.11 DTS Head SAR**

MEASUREMENT RESULTS																
FREQUENCY		Mode	Maximum Allowed Power [dBm]	Conducted Power [dBm]	Drift Power [dB]	Phantom Position	Device Serial Number	Peak SAR of Area Scan	Data Rate [Mbps]	Duty Cycle	1g SAR (W/kg)	Scaling Factor	Scaling Factor (Duty Cycle)	1g Scaled SAR (W/kg)	Plots #	
MHz	Ch															
2462	11	802.11b	16.7	16.61	0.040	Left Touch	FCC #1	0.0704	1	97.6	-	1.021	1.025	-		
2462	11	802.11b	16.7	16.61	-0.030	Right Touch	FCC #1	0.0951	1	97.6	0.097	1.021	1.025	0.102	A11	
2462	11	802.11b	16.7	16.61	0.150	Left Tilt	FCC #1	0.0173	1	97.6	-	1.021	1.025	-		
2462	11	802.11b	16.7	16.61	-0.070	Right Tilt	FCC #1	0.0142	1	97.6	-	1.021	1.025	-		
ANSI / IEEE C95.1-2005– SAFETY LIMIT Spatial Peak Uncontrolled Exposure/General Population Exposure										Head 1.6 W/kg (mW/g) averaged over 1 gram						

Note: Highest reported SAR is ≤ 0.4 W/kg. Therefore, further SAR measurements within this exposure condition are not required.

Adjusted SAR results for OFDM SAR												
FREQUENCY		Mode/ Antenna	Service	Maximum Allowed Power [dBm]	1g Scaled SAR (W/kg)	FREQUENCY [MHz]	Mode	Service	Maximum Allowed Power [dBm]	Ratio of OFDM to DSSS	1g Adjusted SAR (W/kg)	Determine OFDM SAR
MHz	Ch											
2462	11	802.11b	DSSS	16.7	0.101	2462	802.11g	OFDM	13.3	0.457	0.046	X
2462	11	802.11b	DSSS	16.7	0.101	2462	802.11n HT20	OFDM	11.6	0.309	0.031	X
ANSI / IEEE C95.1-2005– SAFETY LIMIT Spatial Peak Uncontrolled Exposure/General Population Exposure							Head 1.6 W/kg (mW/g) averaged over 1 gram					



Table 12.12 U-NII Head SAR

MEASUREMENT RESULTS

FREQUENCY		Mode	Maximum Allowed Power [dBm]	Conducted Power [dBm]	Drift Power [dB]	Phantom Position	Device Serial Number	Peak SAR of Area Scan	Data Rate [Mbps]	Duty Cycle	1g SAR (W/kg)	Scaling Factor	Scaling Factor (Duty Cycle)	1g Scaled SAR (W/kg)	Plots #
MHz	Ch														
5260	52	802.11a	11.0	10.80	-	Left Touch	FCC #1	0.0334	6	87.2	-	1.047	1.147	-	
5260	52	802.11a	11.0	10.80	0.000	Right Touch	FCC #1	0.053	6	87.2	0.038	1.047	1.147	0.046	A30
5260	52	802.11a	11.0	10.80	-	Left Tilt	FCC #1	0.0087	6	87.2	-	1.047	1.147	-	
5260	52	802.11a	11.0	10.80	-	Right Tilt	FCC #1	0.0143	6	87.2	-	1.047	1.147	-	
5580	116	802.11a	10.6	10.50	0.000	Left Touch	FCC #1	0.0287	6	87.2	0.032	1.023	1.147	0.038	A31
5580	116	802.11a	10.6	10.50	-	Right Touch	FCC #1	0.0262	6	87.2	-	1.023	1.147		
5580	116	802.11a	10.6	10.50	-	Left Tilt	FCC #1	0.010	6	87.2	-	1.023	1.147		
5580	116	802.11a	10.6	10.50	-	Right Tilt	FCC #1	0.0059	6	87.2	-	1.023	1.147		
5745	149	802.11a	10.5	10.34	0.000	Left Touch	FCC #1	0.0462	6	87.2	0.052	1.038	1.147	0.062	A32
5745	149	802.11a	10.5	10.34	-	Right Touch	FCC #1	0.043	6	87.2	-	1.038	1.147		
5745	149	802.11a	10.5	10.34	-	Left Tilt	FCC #1	0.019	6	87.2	-	1.038	1.147		
5745	149	802.11a	10.5	10.34	-	Right Tilt	FCC #1	0.0069	6	87.2	-	1.038	1.147		
ANSI / IEEE C95.1-2005– SAFETY LIMIT Spatial Peak Uncontrolled Exposure/General Population Exposure								Head 1.6 W/kg (mW/g) averaged over 1 gram							

Note: Highest reported SAR is ≤ 0.4 W/kg. Therefore, further SAR measurements within this exposure condition are not required.

Adjusted SAR results for UNII-1 and UNII-2A SAR

FREQUENCY		Mode/ Antenna	Service	Maximum Allowed Power [dBm]	1g Scaled SAR (W/kg)	FREQUENCY [MHz]	Mode	Service	Maximum Allowed Power [dBm]	Adjusted Factor	1g Adjusted SAR (W/kg)	SAR for the band with lower maximum output power
MHz	Ch											
5260	52	802.11a	OFDM	11.00	0.046	5240	802.11a	OFDM	11.00	1.000	0.046	X
5260	52	802.11a	OFDM	11.00	0.046	5240	802.11a	OFDM	11.00	1.000	0.046	X
5260	52	802.11a	OFDM	11.00	0.046	5240	802.11a	OFDM	11.00	1.000	0.046	X
ANSI / IEEE C95.1-2005– SAFETY LIMIT Spatial Peak Uncontrolled Exposure/General Population Exposure						Head 1.6 W/kg (mW/g) averaged over 1 gram						

Note(s):

- U-NII-1 and U-NII-2A Bands: When different maximum output power is specified for the bands, begin SAR measurement in the band with higher specified maximum output power. The highest reported SAR for the tested configuration is adjusted by the ratio of lower to higher specified maximum output power for the two bands. When the adjusted SAR is ≤ 1.2 W/kg, SAR is not required for the band with lower maximum output power in that test configuration.





## 12.2 Standalone Body-Worn SAR Worn SAR Results

Table 12.13 CDMA Body-Worn SAR

MEASUREMENT RESULTS														
FREQUENCY		Mode/ Band	Service	Maximum Allowed Power [dBm]	Conducted Power [dBm]	Drift Power [dB]	Spacing [Side]	Device Serial Number	# of Time Slots	Duty Cycle	1g SAR (W/kg)	Scaling Factor	1g Scaled SAR (W/kg)	Plots #
MHz	Ch													
836.5	384	CDMA 850	TDSO SO32 FCH	25.0	24.51	0.030	10 mm [Rear]	FCC #1	N/A	1:1	0.239	1.119	0.267	A12
1851.3	25	CDMA 1900	TDSO SO32 FCH	24.2	24.04	0.040	10 mm [Rear]	FCC #1	N/A	1:1	0.773	1.038	0.802	
1880.0	600	CDMA 1900	TDSO SO32 FCH	24.2	24.04	-0.030	10 mm [Rear]	FCC #1	N/A	1:1	0.956	1.038	0.992	A13
1908.8	1175	CDMA 1900	TDSO SO32 FCH	24.2	24.04	0.010	10 mm [Rear]	FCC #1	N/A	1:1	0.765	1.038	0.794	
ANSI / IEEE C95.1-2005– SAFETY LIMIT Spatial Peak Uncontrolled Exposure/General Population Exposure									Body 1.6 W/kg (mW/g) averaged over 1 gram					

Table 12.14 GSM/PCS/GPRS/WCDMA Body-Worn SAR

MEASUREMENT RESULTS														
FREQUENCY		Mode/ Band	Service	Maximum Allowed Power [dBm]	Conducted Power [dBm]	Drift Power [dB]	Spacing [Side]	Device Serial Number	# of Time Slots	Duty Cycle	1g SAR (W/kg)	Scaling Factor	1g Scaled SAR (W/kg)	Plots #
MHz	Ch													
836.6	190	GSM850	GSM	33.5	33.32	0.000	10 mm [Rear]	FCC #1	1	1:8.3	0.175	1.042	0.182	A14
836.6	190	GSM850	GPRS	33.5	33.32	0.020	10 mm [Rear]	FCC #1	1	1:8.3	0.176	1.042	0.183	
836.6	190	GSM850	GPRS	31.7	31.56	0.050	10 mm [Rear]	FCC #1	2	1:4.15	0.241	1.033	0.249	
836.6	190	GSM850	GPRS	29.9	29.82	0.070	10 mm [Rear]	FCC #1	3	1:2.77	0.278	1.019	0.283	
836.6	190	GSM850	GPRS	29.3	29.28	0.050	10 mm [Rear]	FCC #1	4	1:2.075	0.350	1.005	0.352	A15
1880.0	661	GSM1900	PCS	30.2	30.17	-0.020	10 mm [Rear]	FCC #1	1	1:8.3	0.677	1.007	0.682	A16
1880.0	661	GSM1900	GPRS	26.4	26.34	0.020	10 mm [Rear]	FCC #1	4	1:2.075	0.717	1.014	0.727	A17
836.6	4183	WCDMA 850	RMC	24.2	23.96	0.040	10 mm [Rear]	FCC #1	N/A	1:1	0.211	1.057	0.223	A18
1880.0	9400	WCDMA 1900	RMC	23.7	23.62	0.020	10 mm [Rear]	FCC #1	N/A	1:1	0.740	1.019	0.754	A19
ANSI / IEEE C95.1-2005– SAFETY LIMIT Spatial Peak Uncontrolled Exposure/General Population Exposure									Body 1.6 W/kg (mW/g) averaged over 1 gram					



**Table 12.15 LTE Body-Worn SAR**

MEASUREMENT RESULTS																	
FREQUENCY		Mode/ Band	BW [MHz]	Max Allowed Power [dBm]	Cond. PWR [dBm]	Drift Power [dB]	MPR	Position	Device Serial Number	Mod.	RB Size	RB Offs.	Duty Cycle	1g SAR (W/kg)	Scaling Factor	1g Scaled SAR (W/kg)	Plots #
MHz	Ch																
710.0	23790	LTE B17	10	24.0	23.87	0.060	0	10 mm [Rear]	FCC #1	QPSK	1	0	1:1	0.226	1.030	0.233	A20
710.0	23790	LTE B17	10	23.0	22.76	0.030	1	10 mm [Rear]	FCC #1	QPSK	25	0	1:1	0.187	1.057	0.198	
836.5	20525	LTE B5	10	24.0	23.88	0.010	0	10 mm [Rear]	FCC #1	QPSK	1	0	1:1	0.149	1.028	0.153	A21
836.5	20525	LTE B5	10	23.0	22.85	0.090	1	10 mm [Rear]	FCC #1	QPSK	25	0	1:1	0.123	1.035	0.127	
1732.5	20175	LTE B4	10	23.0	22.90	-0.130	0	10 mm [Rear]	FCC #1	QPSK	1	0	1:1	0.322	1.023	0.329	A22
1732.5	20175	LTE B4	10	22.0	22.00	-0.100	1	10 mm [Rear]	FCC #1	QPSK	25	0	1:1	0.318	1.000	0.318	
1855.0	18650	LTE B2	10	23.2	23.10	-0.030	0	10 mm [Rear]	FCC #1	QPSK	1	0	1:1	0.740	1.023	0.757	
1880.0	18900	LTE B2	10	23.2	23.19	0.190	0	10 mm [Rear]	FCC #1	QPSK	1	0	1:1	0.866	1.002	0.868	A23
1905.0	19150	LTE B2	10	23.2	22.98	0.030	0	10 mm [Rear]	FCC #1	QPSK	1	0	1:1	0.738	1.052	0.776	
1880.0	18900	LTE B2	10	22.2	22.14	0.020	1	10 mm [Rear]	FCC #1	QPSK	25	0	1:1	0.698	1.014	0.708	
1880.0	18900	LTE B2	10	22.2	22.14	0.000	1	10 mm [Rear]	FCC #1	QPSK	50	0	1:1	0.613	1.014	0.622	
ANSI / IEEE C95.1-2005– SAFETY LIMIT Spatial Peak Uncontrolled Exposure/General Population Exposure									Body 1.6 W/kg (mW/g) averaged over 1 gram								

**Table 12.16 DTS Body-Worn SAR**

MEASUREMENT RESULTS															
FREQUENCY		Mode	Maximum Allowed Power [dBm]	Conducted Power [dBm]	Drift Power [dB]	Phantom Position	Device Serial Number	Peak SAR of Area Scan	Data Rate [Mbps]	Duty Cycle	1g SAR (W/kg)	Scaling Factor	Scaling Factor (Duty Cycle)	SAR (W/kg)	Plots #
MHz	Ch														
2462	11	802.11b	16.7	16.61	0.070	10 mm [Rear]	FCC #1	0.113	1	97.6	-	1.021	1.025	-	
ANSI / IEEE C95.1-2005– SAFETY LIMIT Spatial Peak Uncontrolled Exposure/General Population Exposure									Body 1.6 W/kg (mW/g) averaged over 1 gram						

Note: Highest reported SAR is ≤ 0.4 W/kg. Therefore, further SAR measurements within this exposure condition are not required.



### 12.3 Standalone Wireless router SAR Results

Table 12.17 CDMA Hotspot SAR

MEASUREMENT RESULTS														
FREQUENCY		Mode/ Band	Service	Maximum Allowed Power [dBm]	Conducted Power [dBm]	Drift Power [dB]	Spacing [Side]	Device Serial Number	# of Time Slots	Duty Cycle	1g SAR (W/kg)	Scaling Factor	1g Scaled SAR (W/kg)	Plots #
MHz	Ch													
836.5	384	CDMA 850	TDSO SO32 FCH	25.0	24.51	0.010	10 mm [Bottom]	FCC #1	N/A	1:1	0.122	1.119	0.137	
836.5	384	CDMA 850	TDSO SO32 FCH	25.0	24.51	0.040	10 mm [Front]	FCC #1	N/A	1:1	0.181	1.119	0.203	
836.5	384	CDMA 850	TDSO SO32 FCH	25.0	24.51	0.030	10 mm [Rear]	FCC #1	N/A	1:1	0.239	1.119	0.267	A12
836.5	384	CDMA 850	TDSO SO32 FCH	25.0	24.51	-0.100	10 mm [Right]	FCC #1	N/A	1:1	0.177	1.119	0.198	
836.5	384	CDMA 850	TDSO SO32 FCH	25.0	24.51	0.000	10 mm [Left]	FCC #1	N/A	1:1	0.097	1.119	0.109	
1851.3	25	CDMA 1900	TDSO SO32 FCH	24.2	24.04	0.000	10 mm [Bottom]	FCC #1	N/A	1:1	0.854	1.038	0.886	
1880.0	600	CDMA 1900	TDSO SO32 FCH	24.2	24.04	-0.010	10 mm [Bottom]	FCC #1	N/A	1:1	1.070	1.038	1.111	A24
1908.8	1175	CDMA 1900	TDSO SO32 FCH	24.2	24.04	-0.060	10 mm [Bottom]	FCC #1	N/A	1:1	0.860	1.038	0.893	
1880.0	600	CDMA 1900	TDSO SO32 FCH	24.2	24.04	0.050	10 mm [Front]	FCC #1	N/A	1:1	0.205	1.038	0.213	
1851.3	25	CDMA 1900	TDSO SO32 FCH	24.2	24.04	0.040	10 mm [Rear]	FCC #1	N/A	1:1	0.773	1.038	0.802	
1880.0	600	CDMA 1900	TDSO SO32 FCH	24.2	24.04	-0.030	10 mm [Rear]	FCC #1	N/A	1:1	0.956	1.038	0.992	A13
1908.8	1175	CDMA 1900	TDSO SO32 FCH	24.2	24.04	0.010	10 mm [Rear]	FCC #1	N/A	1:1	0.765	1.038	0.794	
1880.0	600	CDMA 1900	TDSO SO32 FCH	24.2	24.04	0.170	10 mm [Right]	FCC #1	N/A	1:1	0.0224	1.038	0.023	
1880.0	600	CDMA 1900	TDSO SO32 FCH	24.2	24.04	0.030	10 mm [Left]	FCC #1	N/A	1:1	0.153	1.038	0.159	
1880.0	600	CDMA 1900	TDSO SO32 FCH	24.2	24.04	-0.010	10 mm [Bottom]	FCC #1	N/A	1:1	1.070	1.038	1.111	
ANSI / IEEE C95.1-2005- SAFETY LIMIT Spatial Peak Uncontrolled Exposure/General Population Exposure								Body 1.6 W/kg (mW/g) averaged over 1 gram						

Note: Blue entries represent repeatability measurements.



Table 12.18 GPRS Hotspot SAR

MEASUREMENT RESULTS														
FREQUENCY		Mode/ Band	Service	Maximum Allowed Power [dBm]	Conducted Power [dBm]	Drift Power [dB]	Spacing [Side]	Device Serial Number	# of Time Slots	Duty Cycle	1g SAR (W/kg)	Scaling Factor	1g Scaled SAR (W/kg)	Plots #
MHz	Ch													
836.6	190	GSM850	GPRS	29.3	29.28	0.010	10 mm [Bottom]	FCC #1	4	1:2.075	0.205	1.005	0.206	
836.6	190	GSM850	GPRS	29.3	29.28	-0.010	10 mm [Front]	FCC #1	4	1:2.075	0.313	1.005	0.315	
836.6	190	GSM850	GPRS	33.5	33.32	0.020	10 mm [Rear]	FCC #1	1	1:8.3	0.176	1.042	0.183	
836.6	190	GSM850	GPRS	31.7	31.56	0.050	10 mm [Rear]	FCC #1	2	1:4.15	0.241	1.033	0.249	
836.6	190	GSM850	GPRS	29.9	29.82	0.070	10 mm [Rear]	FCC #1	3	1:2.77	0.278	1.019	0.283	
836.6	190	GSM850	GPRS	29.3	29.28	0.050	10 mm [Rear]	FCC #1	4	1:2.075	0.350	1.005	0.352	A15
836.6	190	GSM850	GPRS	29.3	29.28	0.080	10 mm [Right]	FCC #1	4	1:2.075	0.224	1.005	0.225	
836.6	190	GSM850	GPRS	29.3	29.28	-0.020	10 mm [Left]	FCC #1	4	1:2.075	0.129	1.005	0.130	
1880.0	661	GSM1900	GPRS	30.2	30.17	-0.030	10 mm [Bottom]	FCC #1	1	1:8.3	0.477	1.007	0.480	
1880.0	661	GSM1900	GPRS	28.8	28.70	-0.040	10 mm [Bottom]	FCC #1	2	1:4.15	0.727	1.023	0.744	
1850.2	512	GSM1900	GPRS	27.5	27.08	-0.090	10 mm [Bottom]	FCC #1	3	1:2.77	0.740	1.102	0.815	
1880.0	661	GSM1900	GPRS	27.5	27.50	-0.090	10 mm [Bottom]	FCC #1	3	1:2.77	0.912	1.000	0.912	
1909.8	810	GSM1900	GPRS	27.5	27.35	-0.020	10 mm [Bottom]	FCC #1	3	1:2.77	0.625	1.035	0.647	
1850.2	512	GSM1900	GPRS	26.4	26.02	-0.060	10 mm [Bottom]	FCC #1	4	1:2.075	0.684	1.091	0.746	
1880.0	661	GSM1900	GPRS	26.4	26.34	-0.050	10 mm [Bottom]	FCC #1	4	1:2.075	0.975	1.014	0.989	A25
1909.8	810	GSM1900	GPRS	26.4	26.38	-0.040	10 mm [Bottom]	FCC #1	4	1:2.075	0.919	1.005	0.924	
1880.0	661	GSM1900	GPRS	26.4	26.34	0.020	10 mm [Front]	FCC #1	4	1:2.075	0.196	1.014	0.199	
1880.0	661	GSM1900	GPRS	26.4	26.34	0.020	10 mm [Rear]	FCC #1	4	1:2.075	0.717	1.014	0.727	A17
1880.0	661	GSM1900	GPRS	26.4	26.34	0.140	10 mm [Right]	FCC #1	4	1:2.075	0.0252	1.014	0.026	
1880.0	661	GSM1900	GPRS	26.4	26.34	0.060	10 mm [Left]	FCC #1	4	1:2.075	0.0973	1.014	0.099	
1880.0	661	GSM1900	GPRS	26.4	26.34	-0.100	10 mm [Bottom]	FCC #1	4	1:2.075	0.950	1.014	0.963	
ANSI / IEEE C95.1-2005- SAFETY LIMIT Spatial Peak Uncontrolled Exposure/General Population Exposure								Body 1.6 W/kg (mW/g) averaged over 1 gram						

Note: Blue entries represent repeatability measurements.



Table 12.19 WCDMA Hotspot SAR

MEASUREMENT RESULTS														
FREQUENCY		Mode/ Band	Service	Maximum Allowed Power [dBm]	Conducted Power [dBm]	Drift Power [dB]	Spacing [Side]	Device Serial Number	# of Time Slots	Duty Cycle	1g SAR (W/kg)	Scaling Factor	1g Scaled SAR (W/kg)	Plots #
MHz	Ch													
836.6	4183	WCDMA 850	RMC	24.2	23.96	0.110	10 mm [Bottom]	FCC #1	N/A	1:1	0.111	1.057	0.117	
836.6	4183	WCDMA 850	RMC	24.2	23.96	-0.010	10 mm [Front]	FCC #1	N/A	1:1	0.155	1.057	0.164	
836.6	4183	WCDMA 850	RMC	24.2	23.96	0.040	10 mm [Rear]	FCC #1	N/A	1:1	0.211	1.057	0.223	A18
836.6	4183	WCDMA 850	RMC	24.2	23.96	0.010	10 mm [Right]	FCC #1	N/A	1:1	0.147	1.057	0.155	
836.6	4183	WCDMA 850	RMC	24.2	23.96	0.040	10 mm [Left]	FCC #1	N/A	1:1	0.082	1.057	0.087	
1852.4	9262	WCDMA 1900	RMC	23.7	23.62	-0.040	10 mm [Bottom]	FCC #1	N/A	1:1	0.771	1.019	0.786	
1880.0	9400	WCDMA 1900	RMC	23.7	23.62	-0.040	10 mm [Bottom]	FCC #1	N/A	1:1	1.090	1.019	1.111	A26
1907.6	9538	WCDMA 1900	RMC	23.7	23.62	-0.040	10 mm [Bottom]	FCC #1	N/A	1:1	0.643	1.019	0.655	
1880.0	9400	WCDMA 1900	RMC	23.7	23.62	0.050	10 mm [Front]	FCC #1	N/A	1:1	0.171	1.019	0.174	
1880.0	9400	WCDMA 1900	RMC	23.7	23.62	0.020	10 mm [Rear]	FCC #1	N/A	1:1	0.740	1.019	0.754	A19
1880.0	9400	WCDMA 1900	RMC	23.7	23.62	0.040	10 mm [Right]	FCC #1	N/A	1:1	0.0326	1.019	0.033	
1880.0	9400	WCDMA 1900	RMC	23.7	23.62	0.100	10 mm [Left]	FCC #1	N/A	1:1	0.127	1.019	0.129	
1880.0	9400	WCDMA 1900	RMC	23.7	23.62	0.070	10 mm [Bottom]	FCC #1	N/A	1:1	1.080	1.019	1.101	
ANSI / IEEE C95.1-2005- SAFETY LIMIT Spatial Peak Uncontrolled Exposure/General Population Exposure									Body 1.6 W/kg (mW/g) averaged over 1 gram					

Note: Blue entries represent repeatability measurements.

Table 12.20 LTE Band 17 Hotspot SAR

MEASUREMENT RESULTS																	
FREQUENCY		Mode/ Band	BW [MHz]	Max Allowed Power [dBm]	Cond. PWR [dBm]	Drift Power [dB]	MPR	Position	Device Serial Number	Mod.	RB Size	RB Offs.	Duty Cycle	1g SAR (W/kg)	Scaling Factor	1g Scaled SAR (W/kg)	Plots #
MHz	Ch																
710.0	23790	LTE B17	10	24.0	23.87	0.040	0	10 mm [Bot.]	FCC #1	QPSK	1	0	1:1	0.0348	1.030	0.036	
710.0	23790	LTE B17	10	23.0	22.76	0.120	1	10 mm [Bot.]	FCC #1	QPSK	25	0	1:1	0.0293	1.057	0.031	
710.0	23790	LTE B17	10	24.0	23.87	0.040	0	10 mm [Front]	FCC #1	QPSK	1	0	1:1	0.131	1.030	0.135	
710.0	23790	LTE B17	10	23.0	22.76	-0.010	1	10 mm [Front]	FCC #1	QPSK	25	0	1:1	0.105	1.057	0.111	
710.0	23790	LTE B17	10	24.0	23.87	0.060	0	10 mm [Rear]	FCC #1	QPSK	1	0	1:1	0.226	1.030	0.233	A20
710.0	23790	LTE B17	10	23.0	22.76	0.030	1	10 mm [Rear]	FCC #1	QPSK	25	0	1:1	0.187	1.057	0.198	
710.0	23790	LTE B17	10	24.0	23.87	0.020	0	10 mm [Right]	FCC #1	QPSK	1	0	1:1	0.149	1.030	0.153	
710.0	23790	LTE B17	10	23.0	22.76	0.020	1	10 mm [Right]	FCC #1	QPSK	25	0	1:1	0.127	1.057	0.134	
710.0	23790	LTE B17	10	24.0	23.87	0.030	0	10 mm [Left]	FCC #1	QPSK	1	0	1:1	0.172	1.030	0.177	
710.0	23790	LTE B17	10	23.0	22.76	0.040	1	10 mm [Left]	FCC #1	QPSK	25	0	1:1	0.138	1.057	0.146	
ANSI / IEEE C95.1-2005- SAFETY LIMIT Spatial Peak Uncontrolled Exposure/General Population Exposure									Body 1.6 W/kg (mW/g) averaged over 1 gram								



**Table 12.21 LTE Band 5 (Cell) Hotspot SAR**

**MEASUREMENT RESULTS**

FREQUENCY		Mode/ Band	BW [MHz]	Max Allowed Power [dBm]	Cond. PWR [dBm]	Drift Power [dB]	MPR	Position	Device Serial Number	Mod.	RB Size	RB Offs.	Duty Cycle	1g SAR (W/kg)	Scaling Factor	1g Scaled SAR (W/kg)	Plots #
MHz	Ch																
836.5	20525	LTE B5	10	24.0	23.88	0.070	0	10 mm [Bot.]	FCC #1	QPSK	1	0	1:1	0.0837	1.028	0.086	
836.5	20525	LTE B5	10	23.0	22.85	-0.070	1	10 mm [Bot.]	FCC #1	QPSK	25	0	1:1	0.069	1.035	0.071	
836.5	20525	LTE B5	10	24.0	23.88	-0.150	0	10 mm [Front]	FCC #1	QPSK	1	0	1:1	0.112	1.028	0.115	
836.5	20525	LTE B5	10	23.0	22.85	0.060	1	10 mm [Front]	FCC #1	QPSK	25	0	1:1	0.0916	1.035	0.095	
836.5	20525	LTE B5	10	24.0	23.88	0.010	0	10 mm [Rear]	FCC #1	QPSK	1	0	1:1	0.149	1.028	0.153	A21
836.5	20525	LTE B5	10	23.0	22.85	0.090	1	10 mm [Rear]	FCC #1	QPSK	25	0	1:1	0.123	1.035	0.127	
836.5	20525	LTE B5	10	24.0	23.88	0.050	0	10 mm [Right]	FCC #1	QPSK	1	0	1:1	0.105	1.028	0.108	
836.5	20525	LTE B5	10	23.0	22.85	-0.060	1	10 mm [Right]	FCC #1	QPSK	25	0	1:1	0.0827	1.035	0.086	
836.5	20525	LTE B5	10	24.0	23.88	0.160	0	10 mm [Left]	FCC #1	QPSK	1	0	1:1	0.049	1.028	0.050	
836.5	20525	LTE B5	10	23.0	22.85	0.070	1	10 mm [Left]	FCC #1	QPSK	25	0	1:1	0.0428	1.035	0.044	
ANSI / IEEE C95.1-2005– SAFETY LIMIT Spatial Peak Uncontrolled Exposure/General Population Exposure										Body 1.6 W/kg (mW/g) averaged over 1 gram							

**Table 12.22 LTE Band 4(AWS) Hotspot SAR**

**MEASUREMENT RESULTS**

FREQUENCY		Mode/ Band	BW [MHz]	Max Allowed Power [dBm]	Cond. PWR [dBm]	Drift Power [dB]	MPR	Position	Device Serial Number	Mod.	RB Size	RB Offs.	Duty Cycle	1g SAR (W/kg)	Scaling Factor	1g Scaled SAR (W/kg)	Plots #
MHz	Ch																
1732.5	20175	LTE B4	10	23.0	22.90	-0.090	0	10 mm [Bot.]	FCC #1	QPSK	1	0	1:1	0.359	1.023	0.367	A27
1732.5	20175	LTE B4	10	22.0	22.00	-0.050	1	10 mm [Bot.]	FCC #1	QPSK	25	0	1:1	0.352	1.000	0.352	
1732.5	20175	LTE B4	10	23.0	22.90	0.090	0	10 mm [Front]	FCC #1	QPSK	1	0	1:1	0.0672	1.023	0.069	
1732.5	20175	LTE B4	10	22.0	22.00	0.110	1	10 mm [Front]	FCC #1	QPSK	25	0	1:1	0.0647	1.000	0.065	
1732.5	20175	LTE B4	10	23.0	22.90	-0.130	0	10 mm [Rear]	FCC #1	QPSK	1	0	1:1	0.322	1.023	0.329	A22
1732.5	20175	LTE B4	10	22.0	22.00	-0.100	1	10 mm [Rear]	FCC #1	QPSK	25	0	1:1	0.318	1.000	0.318	
1732.5	20175	LTE B4	10	23.0	22.90	0.030	0	10 mm [Right]	FCC #1	QPSK	1	0	1:1	0.00359	1.023	0.004	
1732.5	20175	LTE B4	10	22.0	22.00	0.010	1	10 mm [Right]	FCC #1	QPSK	25	0	1:1	0.0025	1.000	0.003	
1732.5	20175	LTE B4	10	23.0	22.90	0.160	0	10 mm [Left]	FCC #1	QPSK	1	0	1:1	0.0367	1.023	0.038	
1732.5	20175	LTE B4	10	22.0	22.00	-0.020	1	10 mm [Left]	FCC #1	QPSK	25	0	1:1	0.0364	1.000	0.036	
ANSI / IEEE C95.1-2005– SAFETY LIMIT Spatial Peak Uncontrolled Exposure/General Population Exposure										Body 1.6 W/kg (mW/g) averaged over 1 gram							



Table 12.23 LTE Band 2 (PCS) Hotspot SAR

MEASUREMENT RESULTS

FREQUENCY		Mode/ Band	BW [MHz]	Max Allowed Power [dBm]	Cond. PWR [dBm]	Drift Power [dB]	MPR	Position	Device Serial Number	Mod.	RB Size	RB Offs.	Duty Cycle	1g SAR (W/kg)	Scaling Factor	1g Scaled SAR (W/kg)	Plots #
MHz	Ch																
1855.0	18650	LTE B2	10	23.2	23.10	-0.060	0	10 mm [Bot.]	FCC #1	QPSK	1	0	1:1	0.750	1.023	0.767	
1880.0	18900	LTE B2	10	23.2	23.19	-0.170	0	10 mm [Bot.]	FCC #1	QPSK	1	0	1:1	0.926	1.002	0.928	A28
1905.0	19150	LTE B2	10	23.2	22.98	-0.130	0	10 mm [Bot.]	FCC #1	QPSK	1	0	1:1	0.796	1.052	0.837	
1880.0	18900	LTE B2	10	22.2	22.14	-0.140	1	10 mm [Bot.]	FCC #1	QPSK	25	0	1:1	0.728	1.014	0.738	
1880.0	18900	LTE B2	10	22.2	22.14	-0.070	1	10 mm [Bot.]	FCC #1	QPSK	50	0	1:1	0.716	1.014	0.726	
1880.0	18900	LTE B2	10	23.2	23.19	-0.040	0	10 mm [Front]	FCC #1	QPSK	1	0	1:1	0.185	1.002	0.185	
1880.0	18900	LTE B2	10	22.2	22.14	0.050	1	10 mm [Front]	FCC #1	QPSK	25	0	1:1	0.149	1.014	0.151	
1855.0	18650	LTE B2	10	23.2	23.10	-0.030	0	10 mm [Rear]	FCC #1	QPSK	1	0	1:1	0.740	1.023	0.757	
1880.0	18900	LTE B2	10	23.2	23.19	0.190	0	10 mm [Rear]	FCC #1	QPSK	1	0	1:1	0.866	1.002	0.868	A23
1905.0	19150	LTE B2	10	23.2	22.98	0.030	0	10 mm [Rear]	FCC #1	QPSK	1	0	1:1	0.738	1.052	0.776	
1880.0	18900	LTE B2	10	22.2	22.14	0.020	1	10 mm [Rear]	FCC #1	QPSK	25	0	1:1	0.698	1.014	0.708	
1880.0	18900	LTE B2	10	22.2	22.14	0.000	1	10 mm [Rear]	FCC #1	QPSK	50	0	1:1	0.613	1.014	0.622	
1880.0	18900	LTE B2	10	23.2	23.19	0.100	0	10 mm [Right]	FCC #1	QPSK	1	0	1:1	0.0198	1.002	0.020	
1880.0	18900	LTE B2	10	22.2	22.14	0.120	1	10 mm [Right]	FCC #1	QPSK	25	0	1:1	0.0151	1.014	0.015	
1880.0	18900	LTE B2	10	23.2	23.19	0.070	0	10 mm [Left]	FCC #1	QPSK	1	0	1:1	0.0912	1.002	0.091	
1880.0	18900	LTE B2	10	22.2	22.14	0.070	1	10 mm [Left]	FCC #1	QPSK	25	0	1:1	0.076	1.014	0.077	
1880.0	18900	LTE B2	10	23.2	23.19	-0.030	0	10 mm [Bot.]	FCC #1	QPSK	1	0	1:1	0.902	1.002	0.904	
ANSI / IEEE C95.1-2005- SAFETY LIMIT Spatial Peak Uncontrolled Exposure/General Population Exposure										Body 1.6 W/kg (mW/g) averaged over 1 gram							

Note: Blue entries represent repeatability measurements.

Table 12.24 W-LAN Hotspot SAR

MEASUREMENT RESULTS

FREQUENCY		Mode	Maximum Allowed Power [dBm]	Conducted Power [dBm]	Drift Power [dB]	Phantom Position	Device Serial Number	Peak SAR of Area Scan	Data Rate [Mbps]	Duty Cycle	1g SAR (W/kg)	Scaling Factor	Scaling Factor (Duty Cycle)	SAR (W/kg)	Plots #
MHz	Ch														
2462	11	802.11b	16.7	16.61	0.110	10 mm [Front]	FCC #1	0.0456	1	97.6	-	1.021	1.025	-	
2462	11	802.11b	16.7	16.61	0.070	10 mm [Rear]	FCC #1	0.113	1	97.6	-	1.021	1.025	-	
2462	11	802.11b	16.7	16.61	0.120	10 mm [Right]	FCC #1	0.134	1	97.6	0.149	1.021	1.025	0.156	A29
ANSI / IEEE C95.1-2005- SAFETY LIMIT Spatial Peak Uncontrolled Exposure/General Population Exposure										Body 1.6 W/kg (mW/g) averaged over 1 gram					

Note: Highest reported SAR is ≤ 0.4 W/kg. Therefore, further SAR measurements within this exposure condition are not required.

Adjusted SAR results for OFDM SAR

FREQUENCY		Mode/ Antenna	Service	Maximum Allowed Power [dBm]	1g Scaled SAR (W/kg)	FREQUENCY [MHz]	Mode	Service	Maximum Allowed Power [dBm]	Ratio of OFDM to DSSS	1g Adjusted SAR (W/kg)	Determine OFDM SAR
MHz	Ch											
2462	11	802.11b	DSSS	16.7	0.156	2462	802.11g	OFDM	13.3	0.457	0.071	X
2462	11	802.11b	DSSS	16.7	0.156	2462	802.11n HT20	OFDM	11.6	0.309	0.048	X
ANSI / IEEE C95.1-2005- SAFETY LIMIT Spatial Peak Uncontrolled Exposure/General Population Exposure								Body 1.6 W/kg (mW/g) averaged over 1 gram				

## 12.4 SAR Test Notes

### General Notes:

1. The test data reported are the worst-case SAR values according to test procedures specified in IEEE 1528-2013, and FCC KDB Publication 447498 D01v06.
2. Batteries are fully charged at the beginning of the SAR measurements. A standard battery was used for all SAR measurements.
3. Liquid tissue depth was at least 15.0 cm for all frequencies.
4. The manufacturer has confirmed that the device(s) tested have the same physical, mechanical and thermal characteristics and are within operational tolerances expected for production units
5. SAR results were scaled to the maximum allowed power to demonstrate compliance per FCC KDB Publication 447498 D01v06.
6. Device was tested using a fixed spacing for body-worn accessory testing. A separation distance of 10 mm was considered because the manufacturer has determined that there will be body-worn accessories available in the marketplace for users to support this separation distance.
7. Per FCC KDB Publication 648474 D04v01r03, SAR was evaluated without a headset connected to the device. Since the standalone reported SAR was not > 1.2 W/kg, no additional SAR evaluations using a headset cable were performed.
8. During SAR Testing for the Wireless Router conditions per FCC KDB Publication 941225 D06v02r01, the actual Portable Hotspot operation (with actual simultaneous transmission of a transmitter with WIFI) was not activated (See Section 6.7 for more details).
9. Per FCC KDB 865664 D01v01r04, variability SAR tests were performed when the measured SAR results for a frequency band were greater than 0.8 W/kg. Repeated SAR measurements are highlighted in the tables above for clarity. Please see Section 14 for variability analysis.

### CDMA Notes:

1. Head SAR for CDMA2000 mode was tested under RC3/SO55 per FCC KDB Publication 941225 D01v03r01.
2. Body-Worn SAR was tested with 1x RTT with TDSO / SO32 FCH Only. EVDO and TDSO / SO32 FCH+SCH SAR tests were not required since the average output power was not more than 0.25 dB higher than the TDSO / SO32 FCH only powers, per FCC KDB Publication 941225 D01v03r01.
3. Per FCC KDB Publication 447498 D01v06, if the reported (scaled) SAR measured at the middle channel or highest output power channel for each test configuration is  $\leq 0.8$  W/kg then testing at the other channels is not required for such test configuration(s). When the maximum output power variation across the required test channels is  $> \frac{1}{2}$  dB, instead of the middle channel, the highest output power channel must be used.

### GSM Notes:

1. Body-Worn accessory testing is typically associated with voice operations. Therefore, GSM voice was evaluated for body-worn SAR.
2. This device supports GSM VOIP in the head and body-worn configurations; therefore GPRS was additionally evaluated for head and body-worn compliance.
3. Justification for reduced test configurations per KDB Publication 941225 D01v03r01 and October 2013 TCB Workshop Notes: The source-based frame-averaged output power was evaluated for all GPRS/EDGE slot configurations. The configuration with the highest target frame averaged output power was evaluated for hotspot SAR. When the maximum frame-averaged powers are equivalent across two or more slots (within 0.25 dB), the configuration with the most number of time slots was tested.
4. Per FCC KDB Publication 447498 D01v06, if the reported (scaled) SAR measured at the middle channel or highest output power channel for each test configuration is  $\leq 0.8$  W/kg then testing at the other channels is not required for such test configuration(s). Since the maximum output power variation across the required test channels is not  $> \frac{1}{2}$  dB, the middle channel was used for testing.



**WCDMA (UMTS) Notes:**

1. WCDMA (UMTS) mode in was tested under RMC 12.2 kbps with HSPA Inactive per KDB Publication 941225 D01v03r01. HSPA SAR was not required since the average output power of the HSPA subtests was not more than 0.25 dB higher than the RMC level and SAR was less than 1.2 W/kg.
2. Per FCC KDB Publication 447498 D01v06, if the reported (scaled) SAR measured at the middle channel or highest output power channel for each test configuration is  $\leq 0.8$  W/kg then testing at the other channels is not required for such test configuration(s). When the maximum output power variation across the required test channels is  $> \frac{1}{2}$  dB, instead of the middle channel, the highest output power channel was used.

**LTE Notes:**

1. LTE Considerations: LTE test configurations are determined according to SAR Evaluation Considerations for LTE Devices in FCC KDB Publication 941225 D05v02r04. The general test procedures used for testing can be found in Section 4.1.
2. MPR is permanently implemented for this device by the manufacturer. The specific manufacturer target MPR is indicated alongside the SAR results. MPR is enabled for this device, according to 3GPP TS36. 101 Section 6.2.3 – 6.2.5 under Table 6.2.3-1.

**WLAN Notes:**

1. The initial test position procedures were applied. The test position with the highest extrapolated peak SAR will be used as the initial test position. When reported SAR for the initial test position is  $\leq 0.4$  W/kg, no additional testing for the remaining test positions was required. Otherwise, SAR is evaluated at the subsequent highest peak SAR positions until the reported SAR result is  $\leq 0.8$  W/kg or all test positions are measured.
2. Justification for test configurations for WLAN per KDB Publication 248227 D01v02r02 for 2.4 GHz WIFI single transmission chain operations, the highest measured maximum output power channel for DSSS was selected for SAR measurement. SAR for OFDM modes (2.4 GHz 802.11g/n) was not required due to the maximum allowed powers and the highest reported DSSS SAR when the highest reported SAR for DSSS is adjusted by the ratio of OFDM to DSSS specified maximum output and the adjusted SAR is  $\leq 1.2$  W/kg.
3. Justification for test configurations for WLAN per KDB Publication 248227 D01v02r02 for 5 GHz WIFI single transmission chain operations, the initial test configuration was selected according to the transmission mode with the highest maximum allowed powers. Other transmission modes were not investigated since the highest reported SAR for initial test configuration adjusted by the ratio of maximum output powers is less than 1.2 W/kg.
4. When the maximum reported 1g averaged SAR  $\leq 0.8$  W/kg, SAR testing on additional channels was not required. Otherwise, SAR for the next highest output power channel was required until the reported SAR result was  $\leq 1.20$  W/kg or all test channels were measured.
5. The device was configured to transmit continuously at the required data rate, channel bandwidth and signal modulation, using the highest transmission duty factor to determine compliance.

## 13. FCC MULTI-TX AND ANTENNA SAR CONSIDERATIONS

### 13.1 Introduction

The following procedures adopted from FCC KDB Publication 447498 D01v06 are applicable to handsets with built-in unlicensed transmitters such as 802.11b/g/n and Bluetooth devices which may simultaneously transmit with the licensed transmitter.

### 13.2 Simultaneous Transmission Procedures

This device contains transmitters that may operate simultaneously. Therefore simultaneous transmission analysis is required. Per FCC KDB 447498 D01v06 4.3.2 and IEEE 1528-2013 Section 6.3.4.1.2, simultaneous transmission SAR test exclusion may be applied when the sum of the 1-g SAR for all the simultaneous transmitting antennas in a specific physical test configuration is  $\leq 1.6$  W/kg. When standalone SAR is not required to be measured, per FCC KDB 447498 D01v06 4.3.2 b), the following equation must be used to estimate the standalone 1g SAR for simultaneous transmission assessment involving that transmitter.

$$\text{Estimated SAR} = \frac{\sqrt{f(\text{GHz})}}{7.5} * \frac{(\text{Max Power of channel, mW})}{\text{Min. Separation Distance, mm}}$$

Table 13.1 Estimated SAR

Mode	Frequency	Maximum Allowed Power		Separation Distance (Body)	Estimated SAR (Body)
	[MHz]	[dBm]	[mW]	[mm]	[W/kg]
Bluetooth	2441	7.5	6	10	0.117

Note: Held-to ear configurations are not applicable to Bluetooth operations and therefore were not considered for simultaneous transmission. Per KDB Publication 447498 D01v06, the maximum power of the channel was rounded to the nearest mW before calculation.

### 13.3 Simultaneous Transmission Capabilities

According to FCC KDB Publication 447498 D01v06, transmitters are considered to be transmitting simultaneously when there is overlapping transmission, with the exception of transmissions during network hand-offs with maximum hand-off duration less than 30 seconds. Possible transmission paths for the DUT are shown in Figure 13.1 and are color-coded to indicate communication modes which share the same path. Modes which share the same transmission path cannot transmit simultaneously with one another.



Figure 13.1 Simultaneous Transmission Paths

This device contains multiple transmitters that may operate simultaneously, and therefore requires a simultaneous transmission analysis according to FCC KDB Publication 447498 D01v06.



**Table 13.2 Simultaneous Transmission Scenarios**

No.	Capable TX Configuration	CDMA 850	CDMA 1900	GSM 850	GSM 1900	WCDMA Band 5	WCDMA Band 2	LTE Band 2	LTE Band 4	LTE Band 5	LTE Band 17	WLAN 2.4 GHz	WLAN 5 GHz	Bluetooth 2.4GHz
1	CDMA850	No	No	No	No	No	No	No	No	No	No	Yes	Yes	Yes
2	CDMA1900	No	No	No	No	No	No	No	No	No	No	Yes	Yes	Yes
3	GSM850	No	No	No	No	No	No	No	No	No	No	Yes	Yes	Yes
4	GSM1900	No	No	No	No	No	No	No	No	No	No	Yes	Yes	Yes
5	WCDMA Band 5	No	No	No	No	No	No	No	No	No	No	Yes	Yes	Yes
6	WCDMA Band 2	No	No	No	No	No	No	No	No	No	No	Yes	Yes	Yes
7	LTE Band 2	No	No	No	No	No	No	No	No	No	No	Yes	No	Yes
8	LTE Band 4	No	No	No	No	No	No	No	No	No	No	Yes	No	Yes
9	LTE Band 5	No	No	No	No	No	No	No	No	No	No	Yes	No	Yes
10	LTE Band 17	No	No	No	No	No	No	No	No	No	No	Yes	No	Yes
11	WLAN 2.4 GHz	Yes	Yes	Yes	Yes	Yes	Yes	Yes	Yes	Yes	Yes	No	No	No
12	WLAN 5 GHz	Yes	Yes	Yes	Yes	Yes	Yes	No	No	No	No	No	No	No
13	Bluetooth 2.4GHz	Yes	Yes	Yes	Yes	Yes	Yes	Yes	Yes	Yes	Yes	No	No	No

Table 13.3 Simultaneous SAR Cases

No.	Capable Transmit Configuration	Head SAR	Body SAR	Note
1	CDMA 850 + WLAN 2.4GHz	Yes	Yes	
2	CDMA 1900 + WLAN 2.4GHz	Yes	Yes	
3	CDMA 850 + WLAN 5GHz	Yes	Yes	
4	CDMA 1900 + WLAN 5GHz	Yes	Yes	
5	CDMA 850 + Bluetooth 2.4GHz	Yes	Yes	
6	CDMA 1900 + Bluetooth 2.4GHz	Yes	Yes	
7	GSM850 Voice + WLAN 2.4GHz	Yes	Yes	
8	GSM1900 Voice + WLAN 2.4GHz	Yes	Yes	
9	GSM850 Voice + WLAN 5GHz	Yes	Yes	
10	GSM1900 Voice + WLAN 5GHz	Yes	Yes	
11	GSM850 Voice + Bluetooth 2.4GHz	Yes	Yes	
12	GSM1900 Voice + Bluetooth 2.4GHz	Yes	Yes	
13	GSM850 GPRS/EDGE + WLAN 2.4GHz	Yes	Yes	* Pre-installed VoIP applications are considered.
14	GSM1900 GPRS/EDGE + WLAN 2.4GHz	Yes	Yes	
15	GSM850 GPRS/EDGE + WLAN 5GHz	Yes	Yes	* Pre-installed VoIP applications are considered.
16	GSM1900 GPRS/EDGE + WLAN 5GHz	Yes	Yes	
17	GSM850 GPRS/EDGE + Bluetooth 2.4GHz	Yes	Yes	* Pre-installed VoIP applications are considered.
18	GSM1900 GPRS/EDGE + Bluetooth 2.4GHz	Yes	Yes	
19	WCDMA Band 5 + WLAN 2.4GHz	Yes	Yes	
20	WCDMA Band 2 + WLAN 2.4GHz	Yes	Yes	
21	WCDMA Band 5 + WLAN 5GHz	Yes	Yes	
22	WCDMA Band 2 + WLAN 5GHz	Yes	Yes	
23	WCDMA Band 5 + Bluetooth 2.4GHz	Yes	Yes	
24	WCDMA Band 2 + Bluetooth 2.4GHz	Yes	Yes	
25	LTE B2, B4, B5, B17 + WLAN 2.4GHz	Yes	Yes	* Pre-installed VoIP applications are considered.
26	LTE B2, B4, B5, B17 + WLAN 5GHz	No	No	
27	LTE B2, B4, B5, B17 + Bluetooth 2.4GHz	Yes	Yes	* Pre-installed VoIP applications are considered.

## Notes:

1. CDMA, GSM, WCDMA and LTE can not transmit simultaneously since they share the same chip.
2. Bluetooth & WLAN (2.4GHz, 5GHz) are not operated at same time.
3. VoIP is supported. (e.g. 3rd part VoIP)

## Note:

- When the user utilizes multiple services in UMTS 3G mode it uses multi-Radio Access Bearer or multi-RAB. The power control is based on a physical control channel (Dedicated Physical Control Channel [DPCCH]) and power control will be adjusted to meet the needs of both services. Therefore, the UMTS+WLAN scenario also represents the UMTS Voice/DATA + WLAN Hotspot scenario.
- Per the manufacturer, WIFI Direct is not expected to be used in conjunction with a held-to-ear or body voice call. Therefore, there are no simultaneous transmission scenarios involving WIFI direct beyond that listed in the above table.

### 13.4 Head SAR Simultaneous Transmission Analysis

Table 13.4 Simultaneous Transmission Scenario for CDMA with 2.4 GHz W-LAN (Held to Ear)

Simult TX	Configuration	CDMA 850 SAR (W/kg)	2.4G W-LAN (802.11b) SAR (W/kg)	$\Sigma$ SAR (W/kg)	Simult TX	Configuration	CDMA 1900 SAR (W/kg)	2.4G W-LAN (802.11b) SAR (W/kg)	$\Sigma$ SAR (W/kg)
Head SAR	Left Touch	0.188	-	0.188	Head SAR	Left Touch	0.103	-	0.103
	Right Touch	0.221	0.102	0.323		Right Touch	0.077	0.102	0.179
	Left Tilt	0.107	-	0.107		Left Tilt	0.024	-	0.024
	Right Tilt	0.109	-	0.109		Right Tilt	0.053	-	0.053

Table 13.5 Simultaneous Transmission Scenario for GSM with 2.4 GHz W-LAN (Held to Ear)

Simult TX	Configuration	GSM850 SAR (W/kg)	2.4G W-LAN (802.11b) SAR (W/kg)	$\Sigma$ SAR (W/kg)	Simult TX	Configuration	GSM1900 SAR (W/kg)	2.4G W-LAN (802.11b) SAR (W/kg)	$\Sigma$ SAR (W/kg)
Head SAR	Left Touch	0.121	-	0.121	Head SAR	Left Touch	0.034	-	0.034
	Right Touch	0.135	0.102	0.237		Right Touch	0.025	0.102	0.127
	Left Tilt	0.070	-	0.070		Left Tilt	0.006	-	0.006
	Right Tilt	0.079	-	0.079		Right Tilt	0.009	-	0.009

Table 13.6 Simultaneous Transmission Scenario for GPRS with 2.4 GHz W-LAN (Held to Ear)

Simult TX	Configuration	GPRS 850 SAR (W/kg)	2.4G W-LAN (802.11b) SAR (W/kg)	$\Sigma$ SAR (W/kg)	Simult TX	Configuration	GPRS 1900 SAR (W/kg)	2.4G W-LAN (802.11b) SAR (W/kg)	$\Sigma$ SAR (W/kg)
Head SAR	Left Touch	0.240	-	0.240	Head SAR	Left Touch	0.076	-	0.076
	Right Touch	0.268	0.102	<b>0.370</b>		Right Touch	0.052	0.102	0.154
	Left Tilt	0.141	-	0.141		Left Tilt	0.014	-	0.014
	Right Tilt	0.163	-	0.163		Right Tilt	0.022	-	0.022

Table 13.7 Simultaneous Transmission Scenario for WCDMA with 2.4 GHz W-LAN (Held to Ear)

Simult TX	Configuration	WCDMA 850 SAR (W/kg)	2.4G W-LAN (802.11b) SAR (W/kg)	$\Sigma$ SAR (W/kg)	Simult TX	Configuration	WCDMA 1900 SAR (W/kg)	2.4G W-LAN (802.11b) SAR (W/kg)	$\Sigma$ SAR (W/kg)
Head SAR	Left Touch	0.159	-	0.159	Head SAR	Left Touch	0.069	-	0.069
	Right Touch	0.193	0.102	0.295		Right Touch	0.048	0.102	0.150
	Left Tilt	0.097	-	0.097		Left Tilt	0.015	-	0.015
	Right Tilt	0.100	-	0.100		Right Tilt	0.035	-	0.035



**Table 13.8 Simultaneous Transmission Scenario for LTE with 2.4 GHz W-LAN (Held to Ear)**

Simult TX	Configuration	LTE Band 17 SAR (W/kg)	2.4G W-LAN (802.11b) SAR (W/kg)	ΣSAR (W/kg)	Simult TX	Configuration	LTE Band 5 SAR (W/kg)	2.4G W-LAN (802.11b) SAR (W/kg)	ΣSAR (W/kg)
Head SAR	Left Touch	0.103	-	0.103	Head SAR	Left Touch	0.115	-	0.115
	Right Touch	0.104	0.102	0.206		Right Touch	0.126	0.102	0.228
	Left Tilt	0.059	-	0.059		Left Tilt	0.068	-	0.068
	Right Tilt	0.061	-	0.061		Right Tilt	0.057	-	0.057
Simult TX	Configuration	LTE Band 4 SAR (W/kg)	2.4G W-LAN (802.11b) SAR (W/kg)	ΣSAR (W/kg)	Simult TX	Configuration	LTE Band 2 SAR (W/kg)	2.4G W-LAN (802.11b) SAR (W/kg)	ΣSAR (W/kg)
Head SAR	Left Touch	0.024	-	0.024	Head SAR	Left Touch	0.101	-	0.101
	Right Touch	0.010	0.102	0.112		Right Touch	0.055	0.102	0.157
	Left Tilt	0.007	-	0.007		Left Tilt	0.023	-	0.023
	Right Tilt	0.010	-	0.010		Right Tilt	0.037	-	0.037

**Table 13.9 Simultaneous Transmission Scenario for CDMA with 5.3 & 5.8 GHz W-LAN (Held to Ear)**

Simult TX	Configuration	CDMA 850 SAR (W/kg)	5.3G & 5.8G W-LAN (802.11a) SAR (W/kg)	ΣSAR (W/kg)	Simult TX	Configuration	CDMA 1900 SAR (W/kg)	5.3G & 5.8G W-LAN (802.11a) SAR (W/kg)	ΣSAR (W/kg)
Head SAR	Left Touch	0.188	0.062 <sup>Note 2</sup>	0.250	Head SAR	Left Touch	0.103	0.062 <sup>Note 2</sup>	0.165
	Right Touch	0.221	0.046 <sup>Note 1</sup>	0.267		Right Touch	0.077	0.046 <sup>Note 1</sup>	0.123
	Left Tilt	0.107	-	0.107		Left Tilt	0.024	-	0.024
	Right Tilt	0.109	-	0.109		Right Tilt	0.053	-	0.053

**Table 13.10 Simultaneous Transmission Scenario for GSM with 5.3 & 5.8 GHz W-LAN (Held to Ear)**

Simult TX	Configuration	GSM850 SAR (W/kg)	5.3G & 5.8G W-LAN (802.11a) SAR (W/kg)	ΣSAR (W/kg)	Simult TX	Configuration	GSM 1900 SAR (W/kg)	5.3G & 5.8G W-LAN (802.11a) SAR (W/kg)	ΣSAR (W/kg)
Head SAR	Left Touch	0.121	0.062 <sup>Note 2</sup>	0.183	Head SAR	Left Touch	0.034	0.062 <sup>Note 2</sup>	0.096
	Right Touch	0.135	0.046 <sup>Note 1</sup>	0.181		Right Touch	0.025	0.046 <sup>Note 1</sup>	0.071
	Left Tilt	0.070	-	0.070		Left Tilt	0.006	-	0.006
	Right Tilt	0.079	-	0.079		Right Tilt	0.009	-	0.009

**Table 13.11 Simultaneous Transmission Scenario for GPRS with 5.3 & 5.8 GHz W-LAN (Held to Ear)**

Simult TX	Configuration	GPRS 850 SAR (W/kg)	5.3G & 5.8G W-LAN (802.11a) SAR (W/kg)	ΣSAR (W/kg)	Simult TX	Configuration	GPRS 1900 SAR (W/kg)	5.3G & 5.8G W-LAN (802.11a) SAR (W/kg)	ΣSAR (W/kg)
Head SAR	Left Touch	0.240	0.062 <sup>Note 2</sup>	0.302	Head SAR	Left Touch	0.076	0.062 <sup>Note 2</sup>	0.138
	Right Touch	0.268	0.046 <sup>Note 1</sup>	<b>0.314</b>		Right Touch	0.052	0.046 <sup>Note 1</sup>	0.098
	Left Tilt	0.141	-	0.141		Left Tilt	0.014	-	0.014
	Right Tilt	0.163	-	0.163		Right Tilt	0.022	-	0.022

**Table 13.12 Simultaneous Transmission Scenario for WCDMA with 5.3 & 5.8 GHz W-LAN (Held to Ear)**

Simult TX	Configuration	WCDMA 850 SAR (W/kg)	5.3G & 5.8G W-LAN (802.11a) SAR (W/kg)	ΣSAR (W/kg)	Simult TX	Configuration	WCDMA 1900 SAR (W/kg)	5.3G & 5.8G W-LAN (802.11a) SAR (W/kg)	ΣSAR (W/kg)
Head SAR	Left Touch	0.159	0.062 <sup>Note 2</sup>	0.221	Head SAR	Left Touch	0.069	0.062 <sup>Note 2</sup>	0.131
	Right Touch	0.193	0.046 <sup>Note 1</sup>	0.239		Right Touch	0.048	0.046 <sup>Note 1</sup>	0.094
	Left Tilt	0.097	-	0.097		Left Tilt	0.015	-	0.015
	Right Tilt	0.100	-	0.100		Right Tilt	0.035	-	0.035

Note(s):

1. 5.3G W-LAN 802.11a Right Touch SAR Data: 0.046 W/kg
2. 5.8G W-LAN 802.11a Left Touch SAR Data: 0.062 W/kg



**Table 13.13 Simultaneous Transmission Scenario for LTE with 5.3 & 5.8 GHz W-LAN (Held to Ear)**

Simult TX	Configuration	LTE Band 17 SAR (W/kg)	5.3G & 5.8G W-LAN (802.11a) SAR (W/kg)	ΣSAR (W/kg)	Simult TX	Configuration	LTE Band 5 SAR (W/kg)	5.3G & 5.8G W-LAN (802.11a) SAR (W/kg)	ΣSAR (W/kg)
Head SAR	Left Touch	0.103	0.062 <sup>Note 2</sup>	0.165	Head SAR	Left Touch	0.115	0.062 <sup>Note 2</sup>	0.177
	Right Touch	0.104	0.046 <sup>Note 1</sup>	0.150		Right Touch	0.126	0.046 <sup>Note 1</sup>	0.172
	Left Tilt	0.059	-	0.059		Left Tilt	0.068	-	0.068
	Right Tilt	0.061	-	0.061		Right Tilt	0.057	-	0.057
Simult TX	Configuration	LTE Band 4 SAR (W/kg)	5.3G & 5.8G W-LAN (802.11a) SAR (W/kg)	ΣSAR (W/kg)	Simult TX	Configuration	LTE Band 2 SAR (W/kg)	5.3G & 5.8G W-LAN (802.11a) SAR (W/kg)	ΣSAR (W/kg)
Head SAR	Left Touch	0.024	0.062 <sup>Note 2</sup>	0.086	Head SAR	Left Touch	0.101	0.062 <sup>Note 2</sup>	0.163
	Right Touch	0.010	0.046 <sup>Note 1</sup>	0.056		Right Touch	0.055	0.046 <sup>Note 1</sup>	0.101
	Left Tilt	0.007	-	0.007		Left Tilt	0.023	-	0.023
	Right Tilt	0.010	-	0.010		Right Tilt	0.037	-	0.037

Note(s):

1. 5.3G W-LAN 802.11a Right Touch SAR Data: 0.046 W/kg
2. 5.8G W-LAN 802.11a Left Touch SAR Data: 0.062 W/kg



### 13.5 Body-Worn Simultaneous Transmission Analysis

**Table 13.14 Simultaneous Transmission Scenario with 2.4 GHz W-LAN (Body-Worn at 10 mm)**

Configuration	Mode	2G/3G SAR (W/kg)	2.4G W-LAN (802.11b) SAR (W/kg)	ΣSAR (W/kg)
Rear Side	CDMA 850	0.267	-	0.267
Rear Side	CDMA 1900	0.992	-	<b>0.992</b>
Rear Side	GSM 850	0.182	-	0.182
Rear Side	GPRS 850	0.352	-	0.352
Rear Side	GSM 1900	0.682	-	0.682
Rear Side	GPRS 1900	0.727	-	0.727
Rear Side	WCDMA 850	0.223	-	0.223
Rear Side	WCDMA 1900	0.754	-	0.754
Rear Side	LTE Band 17	0.233	-	0.233
Rear Side	LTE Band 5	0.153	-	0.153
Rear Side	LTE Band 4	0.329	-	0.329
Rear Side	LTE Band 2	0.868	-	0.868

Note: Highest reported SAR is  $\leq 0.4$  W/kg. Therefore, further SAR measurements within this exposure condition are not required.

**Table 13.15 Simultaneous Transmission Scenario with Bluetooth (Body-Worn at 10 mm)**

Configuration	Mode	2G/3G SAR (W/kg)	Bluetooth SAR (W/kg)	ΣSAR (W/kg)
Rear Side	CDMA 850	0.267	0.117	0.384
Rear Side	CDMA 1900	0.992	0.117	<b>1.109</b>
Rear Side	GSM 850	0.182	0.117	0.299
Rear Side	GPRS 850	0.352	0.117	0.469
Rear Side	GSM 1900	0.682	0.117	0.799
Rear Side	GPRS 1900	0.727	0.117	0.844
Rear Side	WCDMA 850	0.223	0.117	0.340
Rear Side	WCDMA 1900	0.754	0.117	0.871
Rear Side	LTE Band 17	0.233	0.117	0.350
Rear Side	LTE Band 5	0.153	0.117	0.270
Rear Side	LTE Band 4	0.329	0.117	0.446
Rear Side	LTE Band 2	0.868	0.117	0.985

Note: Bluetooth SAR was not required to be measured per FCC KDB 447498 D01v06. Estimated SAR results were used in the above table to determine simultaneous transmission SAR test exclusion.

### 13.6 Hotspot SAR Simultaneous Transmission Analysis

Per FCC KDB Publication 941225 D06v02r01, the device edges with antennas more than 2.5 cm from edge are not required to be evaluated for SAR ("-").

Table 13.16 Simultaneous Transmission Scenario for CDMA with 2.4GHz W-LAN (Hotspot at 10 mm)

Simult TX	Configuration	CDMA 850 SAR (W/kg)	2.4G W-LAN (802.11b) SAR (W/kg)	ΣSAR (W/kg)	Simult TX	Configuration	CDMA 1900 SAR (W/kg)	2.4G W-LAN (802.11b) SAR (W/kg)	ΣSAR (W/kg)
Body SAR	Top	-	-	-	Body SAR	Top	-	-	-
	Bottom	0.137	-	0.137		Bottom	1.111	-	1.111
	Front	0.203	-	0.203		Front	0.213	-	0.213
	Rear	0.267	-	0.267		Rear	0.992	-	0.992
	Right	0.198	0.156	0.354		Right	0.023	0.156	0.179
	Left	0.109	-	0.109		Left	0.159	-	0.159

Table 13.17 Simultaneous Transmission Scenario for GPRS with 2.4GHz W-LAN (Hotspot at 10 mm)

Simult TX	Configuration	GPRS 850 SAR (W/kg)	2.4G W-LAN (802.11b) SAR (W/kg)	ΣSAR (W/kg)	Simult TX	Configuration	GPRS 1900 SAR (W/kg)	2.4G W-LAN (802.11b) SAR (W/kg)	ΣSAR (W/kg)
Body SAR	Top	-	-	-	Body SAR	Top	-	-	-
	Bottom	0.206	-	0.206		Bottom	0.989	-	0.989
	Front	0.315	-	0.315		Front	0.199	-	0.199
	Rear	0.352	-	0.352		Rear	0.727	-	0.727
	Right	0.225	0.156	0.381		Right	0.026	0.156	0.182
	Left	0.130	-	0.130		Left	0.099	-	0.099

Table 13.18 Simultaneous Transmission Scenario for WCDMA with 2.4GHz W-LAN (Hotspot at 10 mm)

Simult TX	Configuration	WCDMA 850 SAR (W/kg)	2.4G W-LAN (802.11b) SAR (W/kg)	ΣSAR (W/kg)	Simult TX	Configuration	WCDMA 1900 SAR (W/kg)	2.4G W-LAN (802.11b) SAR (W/kg)	ΣSAR (W/kg)
Body SAR	Top	-	-	-	Body SAR	Top	-	-	-
	Bottom	0.117	-	0.117		Bottom	1.111	-	1.111
	Front	0.164	-	0.164		Front	0.174	-	0.174
	Rear	0.223	-	0.223		Rear	0.754	-	0.754
	Right	0.155	0.156	0.311		Right	0.033	0.156	0.189
	Left	0.087	-	0.087		Left	0.129	-	0.129

**Table 13.19 Simultaneous Transmission Scenario for LTE with 2.4GHz W-LAN (Hotspot at 10 mm)**

Simult TX	Configuration	LTE Band 17 SAR (W/kg)	2.4G W-LAN (802.11b) SAR (W/kg)	ΣSAR (W/kg)	Simult TX	Configuration	LTE Band 5 SAR (W/kg)	2.4G W-LAN (802.11b) SAR (W/kg)	ΣSAR (W/kg)
Body SAR	Top	-	-	-	Body SAR	Top	-	-	-
	Bottom	0.036	-	0.036		Bottom	0.086	-	0.086
	Front	0.135	-	0.135		Front	0.115	-	0.115
	Rear	0.233	-	0.233		Rear	0.153	-	0.153
	Right	0.153	0.156	0.309		Right	0.108	0.156	0.264
	Left	0.177	-	0.177		Left	0.050	-	0.050
Simult TX	Configuration	LTE Band 4 SAR (W/kg)	2.4G W-LAN (802.11b) SAR (W/kg)	ΣSAR (W/kg)	Simult TX	Configuration	LTE Band 2 SAR (W/kg)	2.4G W-LAN (802.11b) SAR (W/kg)	ΣSAR (W/kg)
Body SAR	Top	-	-	-	Body SAR	Top	-	-	-
	Bottom	0.367	-	0.367		Bottom	0.928	-	0.928
	Front	0.069	-	0.069		Front	0.185	-	0.185
	Rear	0.329	-	0.329		Rear	0.868	-	0.868
	Right	0.004	0.156	0.160		Right	0.020	0.156	0.176
	Left	0.038	-	0.038		Left	0.091	-	0.091

### 13.7 Simultaneous Transmission Conclusion

The above numerical summed SAR results for all the worst-case simultaneous transmission conditions were below the SAR limit. Therefore, the above analysis is sufficient to determine that simultaneous transmission cases will not exceed the SAR limit and therefore no measured volumetric simultaneous SAR summation is required per FCC KDB Publication 447498 D01v06 and IEEE 1528-2013 Section 6.3.4.1.2.

## 14. SAR MEASUREMENT VARIABILITY

### 14.1 Measurement Variability

Per FCC KDB Publication 865664 D01v01r04, SAR measurement variability was assessed for each frequency band, which was determined by the SAR probe calibration point and tissue-equivalent medium used for the device measurements. When both head and body tissue-equivalent media were required for SAR measurements in a frequency band, the variability measurement procedures were applied to the tissue medium with the highest measured SAR, using the highest measured SAR configuration for that tissue-equivalent medium. These additional measurements were repeated after the completion of all measurements requiring the same head or body tissue-equivalent medium in a frequency band. The test device was returned to ambient conditions (normal room temperature) with the battery fully charged before it was re-mounted on the device holder for the repeated measurement(s) to minimize any unexpected variations in the repeated results.

SAR Measurement Variability was assessed using the following procedures for each frequency band:

1. When the original highest measured SAR is  $\geq 0.80$  W/kg, the measurement was repeated once.
2. A second repeated measurement was performed only if the ratio of largest to smallest SAR for the original and first repeated measurements was  $> 1.20$  or when the original or repeated measurement was  $\geq 1.45$  W/kg (~ 10% from the 1-g SAR limit).
3. A third repeated measurement was performed only if the original, first or second repeated measurement was  $\geq 1.5$  W/kg and the ratio of largest to smallest SAR for the original, first and second repeated measurements is  $> 1.20$ .
4. Repeated measurements are not required when the original highest measured SAR is  $< 0.80$  W/kg

**Table 14.1 Body SAR Measurement Variability Results**

Frequency		Mode	Service	# of Time Slots	Spacing [Side]	Measured SAR (1g)	1st Repeated SAR(1g)	Ratio	2nd Repeated SAR(1g)	Ratio	3rd Repeated SAR(1g)	Ratio
MHz	Ch.					(W/kg)	(W/kg)		(W/kg)		(W/kg)	
1880.0	600	CDMA 1900	TDSO SO32 FCH	N/A	10 mm [Bottom]	1.111	1.111	1.00	N/A	N/A	N/A	N/A
1880.0	661	GSM 1900	GPRS	4	10 mm [Bottom]	0.989	0.963	1.03	N/A	N/A	N/A	N/A
1880.0	9400	WCDMA 1900	RMC	N/A	10 mm [Bottom]	1.111	1.101	1.01	N/A	N/A	N/A	N/A
1880.0	18900	LTE B2	LTE	N/A	10 mm [Bottom]	0.928	0.904	1.03	N/A	N/A	N/A	N/A
ANSI / IEEE C95.1-2005– SAFETY LIMIT Spatial Peak Uncontrolled Exposure/General Population Exposure							Body 1.6 W/kg (mW/g) averaged over 1 gram					

### 14.2 Measurement Uncertainty

The measured SAR was  $< 1.5$  W/kg for all frequency bands. Therefore, per KDB Publication 865664D01v01r04, the standard measurement uncertainty analysis per IEEE 1528-2013 was not required.

## 15. IEEE P1528 –MEASUREMENT UNCERTAINTIES

### 750 MHz Head

Error Description	Uncertainty value $\pm\%$	Probability Distribution	Divisor	(Ci) 1g	Standard (1g)	vi 2 or Veff
<b>Measurement System</b>						
Probe calibration	$\pm 6.0$	Normal	1	1	$\pm 6.0 \%$	$\infty$
Axial isotropy	$\pm 4.7$	Rectangular	$\sqrt{3}$	1	$\pm 2.714 \%$	$\infty$
Hemispherical isotropy	$\pm 9.6$	Rectangular	$\sqrt{3}$	1	$\pm 5.543 \%$	$\infty$
Boundary Effects	$\pm 0.8$	Rectangular	$\sqrt{3}$	1	$\pm 0.462 \%$	$\infty$
Probe Linearity	$\pm 4.7$	Rectangular	$\sqrt{3}$	1	$\pm 2.714 \%$	$\infty$
Detection limits	$\pm 0.25$	Rectangular	$\sqrt{3}$	1	$\pm 0.145 \%$	$\infty$
Readout Electronics	$\pm 1.0$	Normal	1	1	$\pm 1.0 \%$	$\infty$
Response time	$\pm 0.8$	Rectangular	$\sqrt{3}$	1	$\pm 0.462 \%$	$\infty$
Integration time	$\pm 2.6$	Rectangular	$\sqrt{3}$	1	$\pm 1.501 \%$	$\infty$
RF Ambient Conditions	$\pm 3.0$	Rectangular	$\sqrt{3}$	1	$\pm 1.732 \%$	$\infty$
Probe Positioner	$\pm 0.4$	Rectangular	$\sqrt{3}$	1	$\pm 0.231 \%$	$\infty$
Probe Positioning	$\pm 2.9$	Rectangular	$\sqrt{3}$	1	$\pm 1.674 \%$	$\infty$
Algorithms for Max. SAR Eval.	$\pm 1.0$	Rectangular	$\sqrt{3}$	1	$\pm 0.577 \%$	$\infty$
<b>Test Sample Related</b>						
Device Positioning	$\pm 2.9$	Normal	1	1	$\pm 2.9 \%$	145
Device Holder	$\pm 3.6$	Normal	1	1	$\pm 3.6 \%$	5
Power Drift	$\pm 5.0$	Rectangular	$\sqrt{3}$	1	$\pm 2.887 \%$	$\infty$
<b>Physical Parameters</b>						
Phantom Shell	$\pm 4.0$	Rectangular	$\sqrt{3}$	1	$\pm 2.31 \%$	$\infty$
Liquid conductivity (Target)	$\pm 5.0$	Rectangular	$\sqrt{3}$	0.64	$\pm 2.887 \%$	$\infty$
Liquid conductivity (Meas.)	$\pm 4.0$	Normal	1	0.64	$\pm 4.0 \%$	$\infty$
Liquid permittivity (Target)	$\pm 5.0$	Rectangular	$\sqrt{3}$	0.6	$\pm 2.887 \%$	$\infty$
Liquid permittivity (Meas.)	$\pm 4.2$	Normal	1	0.6	$\pm 4.2 \%$	$\infty$
<b>Combined Standard Uncertainty</b>					<b><math>\pm 12.1 \%</math></b>	<b>330</b>
<b>Expanded Uncertainty (k=2)</b>					<b><math>\pm 24.2 \%</math></b>	

The above measurement uncertainties are according to IEEE P1528 (2003)

**750 MHz Body**

Error Description	Uncertainty value $\pm\%$	Probability Distribution	Divisor	(Ci) 1g	Standard (1g)	vi 2 or Veff
<b>Measurement System</b>						
Probe calibration	$\pm 6.0$	Normal	1	1	$\pm 6.0 \%$	$\infty$
Axial isotropy	$\pm 4.7$	Rectangular	$\sqrt{3}$	1	$\pm 2.714 \%$	$\infty$
Hemispherical isotropy	$\pm 9.6$	Rectangular	$\sqrt{3}$	1	$\pm 5.543 \%$	$\infty$
Boundary Effects	$\pm 0.8$	Rectangular	$\sqrt{3}$	1	$\pm 0.462 \%$	$\infty$
Probe Linearity	$\pm 4.7$	Rectangular	$\sqrt{3}$	1	$\pm 2.714 \%$	$\infty$
Detection limits	$\pm 0.25$	Rectangular	$\sqrt{3}$	1	$\pm 0.145 \%$	$\infty$
Readout Electronics	$\pm 1.0$	Normal	1	1	$\pm 1.0 \%$	$\infty$
Response time	$\pm 0.8$	Rectangular	$\sqrt{3}$	1	$\pm 0.462 \%$	$\infty$
Integration time	$\pm 2.6$	Rectangular	$\sqrt{3}$	1	$\pm 1.501 \%$	$\infty$
RF Ambient Conditions	$\pm 3.0$	Rectangular	$\sqrt{3}$	1	$\pm 1.732 \%$	$\infty$
Probe Positioner	$\pm 0.4$	Rectangular	$\sqrt{3}$	1	$\pm 0.231 \%$	$\infty$
Probe Positioning	$\pm 2.9$	Rectangular	$\sqrt{3}$	1	$\pm 1.674 \%$	$\infty$
Algorithms for Max. SAR Eval.	$\pm 1.0$	Rectangular	$\sqrt{3}$	1	$\pm 0.577 \%$	$\infty$
<b>Test Sample Related</b>						
Device Positioning	$\pm 2.9$	Normal	1	1	$\pm 2.9 \%$	145
Device Holder	$\pm 3.6$	Normal	1	1	$\pm 3.6 \%$	5
Power Drift	$\pm 5.0$	Rectangular	$\sqrt{3}$	1	$\pm 2.887 \%$	$\infty$
<b>Physical Parameters</b>						
Phantom Shell	$\pm 4.0$	Rectangular	$\sqrt{3}$	1	$\pm 2.31\%$	$\infty$
Liquid conductivity (Target)	$\pm 5.0$	Rectangular	$\sqrt{3}$	0.64	$\pm 2.887 \%$	$\infty$
Liquid conductivity (Meas.)	$\pm 3.7$	Normal	1	0.64	$\pm 3.7 \%$	$\infty$
Liquid permittivity (Target)	$\pm 5.0$	Rectangular	$\sqrt{3}$	0.6	$\pm 2.887 \%$	$\infty$
Liquid permittivity (Meas.)	$\pm 4.5$	Normal	1	0.6	$\pm 4.5 \%$	$\infty$
<b>Combined Standard Uncertainty</b>					<b><math>\pm 12.1 \%</math></b>	<b>330</b>
<b>Expanded Uncertainty (k=2)</b>					<b><math>\pm 24.2 \%</math></b>	

The above measurement uncertainties are according to IEEE P1528 (2003)

**835 MHz Head**

Error Description	Uncertainty value $\pm\%$	Probability Distribution	Divisor	(Ci) 1g	Standard (1g)	vi 2 or Veff
<b>Measurement System</b>						
Probe calibration	$\pm 6.0$	Normal	1	1	$\pm 6.0 \%$	$\infty$
Axial isotropy	$\pm 4.7$	Rectangular	$\sqrt{3}$	1	$\pm 2.714 \%$	$\infty$
Hemispherical isotropy	$\pm 9.6$	Rectangular	$\sqrt{3}$	1	$\pm 5.543 \%$	$\infty$
Boundary Effects	$\pm 0.8$	Rectangular	$\sqrt{3}$	1	$\pm 0.462 \%$	$\infty$
Probe Linearity	$\pm 4.7$	Rectangular	$\sqrt{3}$	1	$\pm 2.714 \%$	$\infty$
Detection limits	$\pm 0.25$	Rectangular	$\sqrt{3}$	1	$\pm 0.145 \%$	$\infty$
Readout Electronics	$\pm 1.0$	Normal	1	1	$\pm 1.0 \%$	$\infty$
Response time	$\pm 0.8$	Rectangular	$\sqrt{3}$	1	$\pm 0.462 \%$	$\infty$
Integration time	$\pm 2.6$	Rectangular	$\sqrt{3}$	1	$\pm 1.501 \%$	$\infty$
RF Ambient Conditions	$\pm 3.0$	Rectangular	$\sqrt{3}$	1	$\pm 1.732 \%$	$\infty$
Probe Positioner	$\pm 0.4$	Rectangular	$\sqrt{3}$	1	$\pm 0.231 \%$	$\infty$
Probe Positioning	$\pm 2.9$	Rectangular	$\sqrt{3}$	1	$\pm 1.674 \%$	$\infty$
Algorithms for Max. SAR Eval.	$\pm 1.0$	Rectangular	$\sqrt{3}$	1	$\pm 0.577 \%$	$\infty$
<b>Test Sample Related</b>						
Device Positioning	$\pm 2.9$	Normal	1	1	$\pm 2.9 \%$	145
Device Holder	$\pm 3.6$	Normal	1	1	$\pm 3.6 \%$	5
Power Drift	$\pm 5.0$	Rectangular	$\sqrt{3}$	1	$\pm 2.887 \%$	$\infty$
<b>Physical Parameters</b>						
Phantom Shell	$\pm 4.0$	Rectangular	$\sqrt{3}$	1	$\pm 2.31 \%$	$\infty$
Liquid conductivity (Target)	$\pm 5.0$	Rectangular	$\sqrt{3}$	0.64	$\pm 2.887 \%$	$\infty$
Liquid conductivity (Meas.)	$\pm 4.6$	Normal	1	0.64	$\pm 4.6 \%$	$\infty$
Liquid permittivity (Target)	$\pm 5.0$	Rectangular	$\sqrt{3}$	0.6	$\pm 2.887 \%$	$\infty$
Liquid permittivity (Meas.)	$\pm 4.2$	Normal	1	0.6	$\pm 4.2 \%$	$\infty$
<b>Combined Standard Uncertainty</b>					<b><math>\pm 12.2 \%</math></b>	<b>330</b>
<b>Expanded Uncertainty (k=2)</b>					<b><math>\pm 24.4 \%</math></b>	

The above measurement uncertainties are according to IEEE P1528 (2003)

**835 MHz Body**

Error Description	Uncertainty value $\pm\%$	Probability Distribution	Divisor	(Ci) 1g	Standard (1g)	vi 2 or Veff
<b>Measurement System</b>						
Probe calibration	$\pm 6.0$	Normal	1	1	$\pm 6.0 \%$	$\infty$
Axial isotropy	$\pm 4.7$	Rectangular	$\sqrt{3}$	1	$\pm 2.714 \%$	$\infty$
Hemispherical isotropy	$\pm 9.6$	Rectangular	$\sqrt{3}$	1	$\pm 5.543 \%$	$\infty$
Boundary Effects	$\pm 0.8$	Rectangular	$\sqrt{3}$	1	$\pm 0.462 \%$	$\infty$
Probe Linearity	$\pm 4.7$	Rectangular	$\sqrt{3}$	1	$\pm 2.714 \%$	$\infty$
Detection limits	$\pm 0.25$	Rectangular	$\sqrt{3}$	1	$\pm 0.145 \%$	$\infty$
Readout Electronics	$\pm 1.0$	Normal	1	1	$\pm 1.0 \%$	$\infty$
Response time	$\pm 0.8$	Rectangular	$\sqrt{3}$	1	$\pm 0.462 \%$	$\infty$
Integration time	$\pm 2.6$	Rectangular	$\sqrt{3}$	1	$\pm 1.501 \%$	$\infty$
RF Ambient Conditions	$\pm 3.0$	Rectangular	$\sqrt{3}$	1	$\pm 1.732 \%$	$\infty$
Probe Positioner	$\pm 0.4$	Rectangular	$\sqrt{3}$	1	$\pm 0.231 \%$	$\infty$
Probe Positioning	$\pm 2.9$	Rectangular	$\sqrt{3}$	1	$\pm 1.674 \%$	$\infty$
Algorithms for Max. SAR Eval.	$\pm 1.0$	Rectangular	$\sqrt{3}$	1	$\pm 0.577 \%$	$\infty$
<b>Test Sample Related</b>						
Device Positioning	$\pm 2.9$	Normal	1	1	$\pm 2.9 \%$	145
Device Holder	$\pm 3.6$	Normal	1	1	$\pm 3.6 \%$	5
Power Drift	$\pm 5.0$	Rectangular	$\sqrt{3}$	1	$\pm 2.887 \%$	$\infty$
<b>Physical Parameters</b>						
Phantom Shell	$\pm 4.0$	Rectangular	$\sqrt{3}$	1	$\pm 2.31 \%$	$\infty$
Liquid conductivity (Target)	$\pm 5.0$	Rectangular	$\sqrt{3}$	0.64	$\pm 2.887 \%$	$\infty$
Liquid conductivity (Meas.)	$\pm 4.5$	Normal	1	0.64	$\pm 4.5 \%$	$\infty$
Liquid permittivity (Target)	$\pm 5.0$	Rectangular	$\sqrt{3}$	0.6	$\pm 2.887 \%$	$\infty$
Liquid permittivity (Meas.)	$\pm 3.8$	Normal	1	0.6	$\pm 3.8 \%$	$\infty$
<b>Combined Standard Uncertainty</b>					<b><math>\pm 12.1 \%</math></b>	<b>330</b>
<b>Expanded Uncertainty (k=2)</b>					<b><math>\pm 24.2 \%</math></b>	

The above measurement uncertainties are according to IEEE P1528 (2003)



**1800 MHz Head**

Error Description	Uncertainty value $\pm\%$	Probability Distribution	Divisor	(Ci) 1g	Standard (1g)	vi 2 or Veff
<b>Measurement System</b>						
Probe calibration	$\pm 6.0$	Normal	1	1	$\pm 6.0 \%$	$\infty$
Axial isotropy	$\pm 4.7$	Rectangular	$\sqrt{3}$	1	$\pm 2.714 \%$	$\infty$
Hemispherical isotropy	$\pm 9.6$	Rectangular	$\sqrt{3}$	1	$\pm 5.543 \%$	$\infty$
Boundary Effects	$\pm 0.8$	Rectangular	$\sqrt{3}$	1	$\pm 0.462 \%$	$\infty$
Probe Linearity	$\pm 4.7$	Rectangular	$\sqrt{3}$	1	$\pm 2.714 \%$	$\infty$
Detection limits	$\pm 0.25$	Rectangular	$\sqrt{3}$	1	$\pm 0.145 \%$	$\infty$
Readout Electronics	$\pm 1.0$	Normal	1	1	$\pm 1.0 \%$	$\infty$
Response time	$\pm 0.8$	Rectangular	$\sqrt{3}$	1	$\pm 0.462 \%$	$\infty$
Integration time	$\pm 2.6$	Rectangular	$\sqrt{3}$	1	$\pm 1.501 \%$	$\infty$
RF Ambient Conditions	$\pm 3.0$	Rectangular	$\sqrt{3}$	1	$\pm 1.732 \%$	$\infty$
Probe Positioner	$\pm 0.4$	Rectangular	$\sqrt{3}$	1	$\pm 0.231 \%$	$\infty$
Probe Positioning	$\pm 2.9$	Rectangular	$\sqrt{3}$	1	$\pm 1.674 \%$	$\infty$
Algorithms for Max. SAR Eval.	$\pm 1.0$	Rectangular	$\sqrt{3}$	1	$\pm 0.577 \%$	$\infty$
<b>Test Sample Related</b>						
Device Positioning	$\pm 2.9$	Normal	1	1	$\pm 2.9 \%$	145
Device Holder	$\pm 3.6$	Normal	1	1	$\pm 3.6 \%$	5
Power Drift	$\pm 5.0$	Rectangular	$\sqrt{3}$	1	$\pm 2.887 \%$	$\infty$
<b>Physical Parameters</b>						
Phantom Shell	$\pm 4.0$	Rectangular	$\sqrt{3}$	1	$\pm 2.31 \%$	$\infty$
Liquid conductivity (Target)	$\pm 5.0$	Rectangular	$\sqrt{3}$	0.64	$\pm 2.887 \%$	$\infty$
Liquid conductivity (Meas.)	$\pm 4.2$	Normal	1	0.64	$\pm 4.2 \%$	$\infty$
Liquid permittivity (Target)	$\pm 5.0$	Rectangular	$\sqrt{3}$	0.6	$\pm 2.887 \%$	$\infty$
Liquid permittivity (Meas.)	$\pm 3.9$	Normal	1	0.6	$\pm 3.9 \%$	$\infty$
<b>Combined Standard Uncertainty</b>					<b><math>\pm 12.1 \%</math></b>	<b>330</b>
<b>Expanded Uncertainty (k=2)</b>					<b><math>\pm 24.2 \%</math></b>	

The above measurement uncertainties are according to IEEE P1528 (2003)

**1800 MHz Body**

Error Description	Uncertainty value $\pm\%$	Probability Distribution	Divisor	(Ci) 1g	Standard (1g)	vi 2 or Veff
<b>Measurement System</b>						
Probe calibration	$\pm 6.0$	Normal	1	1	$\pm 6.0 \%$	$\infty$
Axial isotropy	$\pm 4.7$	Rectangular	$\sqrt{3}$	1	$\pm 2.714 \%$	$\infty$
Hemispherical isotropy	$\pm 9.6$	Rectangular	$\sqrt{3}$	1	$\pm 5.543 \%$	$\infty$
Boundary Effects	$\pm 0.8$	Rectangular	$\sqrt{3}$	1	$\pm 0.462 \%$	$\infty$
Probe Linearity	$\pm 4.7$	Rectangular	$\sqrt{3}$	1	$\pm 2.714 \%$	$\infty$
Detection limits	$\pm 0.25$	Rectangular	$\sqrt{3}$	1	$\pm 0.145 \%$	$\infty$
Readout Electronics	$\pm 1.0$	Normal	1	1	$\pm 1.0 \%$	$\infty$
Response time	$\pm 0.8$	Rectangular	$\sqrt{3}$	1	$\pm 0.462 \%$	$\infty$
Integration time	$\pm 2.6$	Rectangular	$\sqrt{3}$	1	$\pm 1.501 \%$	$\infty$
RF Ambient Conditions	$\pm 3.0$	Rectangular	$\sqrt{3}$	1	$\pm 1.732 \%$	$\infty$
Probe Positioner	$\pm 0.4$	Rectangular	$\sqrt{3}$	1	$\pm 0.231 \%$	$\infty$
Probe Positioning	$\pm 2.9$	Rectangular	$\sqrt{3}$	1	$\pm 1.674 \%$	$\infty$
Algorithms for Max. SAR Eval.	$\pm 1.0$	Rectangular	$\sqrt{3}$	1	$\pm 0.577 \%$	$\infty$
<b>Test Sample Related</b>						
Device Positioning	$\pm 2.9$	Normal	1	1	$\pm 2.9 \%$	145
Device Holder	$\pm 3.6$	Normal	1	1	$\pm 3.6 \%$	5
Power Drift	$\pm 5.0$	Rectangular	$\sqrt{3}$	1	$\pm 2.887 \%$	$\infty$
<b>Physical Parameters</b>						
Phantom Shell	$\pm 4.0$	Rectangular	$\sqrt{3}$	1	$\pm 2.31 \%$	$\infty$
Liquid conductivity (Target)	$\pm 5.0$	Rectangular	$\sqrt{3}$	0.64	$\pm 2.887 \%$	$\infty$
Liquid conductivity (Meas.)	$\pm 3.6$	Normal	1	0.64	$\pm 3.6 \%$	$\infty$
Liquid permittivity (Target)	$\pm 5.0$	Rectangular	$\sqrt{3}$	0.6	$\pm 2.887 \%$	$\infty$
Liquid permittivity (Meas.)	$\pm 4.0$	Normal	1	0.6	$\pm 4.0 \%$	$\infty$
<b>Combined Standard Uncertainty</b>					<b><math>\pm 12.0 \%</math></b>	<b>330</b>
<b>Expanded Uncertainty (k=2)</b>					<b><math>\pm 24.0 \%</math></b>	

The above measurement uncertainties are according to IEEE P1528 (2003)

**1900 MHz Head**

Error Description	Uncertainty value $\pm\%$	Probability Distribution	Divisor	(Ci) 1g	Standard (1g)	vi 2 or Veff
<b>Measurement System</b>						
Probe calibration	$\pm 6.0$	Normal	1	1	$\pm 6.0 \%$	$\infty$
Axial isotropy	$\pm 4.7$	Rectangular	$\sqrt{3}$	1	$\pm 2.714 \%$	$\infty$
Hemispherical isotropy	$\pm 9.6$	Rectangular	$\sqrt{3}$	1	$\pm 5.543 \%$	$\infty$
Boundary Effects	$\pm 0.8$	Rectangular	$\sqrt{3}$	1	$\pm 0.462 \%$	$\infty$
Probe Linearity	$\pm 4.7$	Rectangular	$\sqrt{3}$	1	$\pm 2.714 \%$	$\infty$
Detection limits	$\pm 0.25$	Rectangular	$\sqrt{3}$	1	$\pm 0.145 \%$	$\infty$
Readout Electronics	$\pm 1.0$	Normal	1	1	$\pm 1.0 \%$	$\infty$
Response time	$\pm 0.8$	Rectangular	$\sqrt{3}$	1	$\pm 0.462 \%$	$\infty$
Integration time	$\pm 2.6$	Rectangular	$\sqrt{3}$	1	$\pm 1.501 \%$	$\infty$
RF Ambient Conditions	$\pm 3.0$	Rectangular	$\sqrt{3}$	1	$\pm 1.732 \%$	$\infty$
Probe Positioner	$\pm 0.4$	Rectangular	$\sqrt{3}$	1	$\pm 0.231 \%$	$\infty$
Probe Positioning	$\pm 2.9$	Rectangular	$\sqrt{3}$	1	$\pm 1.674 \%$	$\infty$
Algorithms for Max. SAR Eval.	$\pm 1.0$	Rectangular	$\sqrt{3}$	1	$\pm 0.577 \%$	$\infty$
<b>Test Sample Related</b>						
Device Positioning	$\pm 2.9$	Normal	1	1	$\pm 2.9 \%$	145
Device Holder	$\pm 3.6$	Normal	1	1	$\pm 3.6 \%$	5
Power Drift	$\pm 5.0$	Rectangular	$\sqrt{3}$	1	$\pm 2.887 \%$	$\infty$
<b>Physical Parameters</b>						
Phantom Shell	$\pm 4.0$	Rectangular	$\sqrt{3}$	1	$\pm 2.31 \%$	$\infty$
Liquid conductivity (Target)	$\pm 5.0$	Rectangular	$\sqrt{3}$	0.64	$\pm 2.887 \%$	$\infty$
Liquid conductivity (Meas.)	$\pm 4.3$	Normal	1	0.64	$\pm 4.3 \%$	$\infty$
Liquid permittivity (Target)	$\pm 5.0$	Rectangular	$\sqrt{3}$	0.6	$\pm 2.887 \%$	$\infty$
Liquid permittivity (Meas.)	$\pm 4.5$	Normal	1	0.6	$\pm 4.5 \%$	$\infty$
<b>Combined Standard Uncertainty</b>					<b><math>\pm 12.2 \%</math></b>	<b>330</b>
<b>Expanded Uncertainty (k=2)</b>					<b><math>\pm 24.4 \%</math></b>	

The above measurement uncertainties are according to IEEE P1528 (2003)

**1900 MHz Body**

Error Description	Uncertainty value $\pm\%$	Probability Distribution	Divisor	(Ci) 1g	Standard (1g)	vi 2 or Veff
<b>Measurement System</b>						
Probe calibration	$\pm 6.0$	Normal	1	1	$\pm 6.0 \%$	$\infty$
Axial isotropy	$\pm 4.7$	Rectangular	$\sqrt{3}$	1	$\pm 2.714 \%$	$\infty$
Hemispherical isotropy	$\pm 9.6$	Rectangular	$\sqrt{3}$	1	$\pm 5.543 \%$	$\infty$
Boundary Effects	$\pm 0.8$	Rectangular	$\sqrt{3}$	1	$\pm 0.462 \%$	$\infty$
Probe Linearity	$\pm 4.7$	Rectangular	$\sqrt{3}$	1	$\pm 2.714 \%$	$\infty$
Detection limits	$\pm 0.25$	Rectangular	$\sqrt{3}$	1	$\pm 0.145 \%$	$\infty$
Readout Electronics	$\pm 1.0$	Normal	1	1	$\pm 1.0 \%$	$\infty$
Response time	$\pm 0.8$	Rectangular	$\sqrt{3}$	1	$\pm 0.462 \%$	$\infty$
Integration time	$\pm 2.6$	Rectangular	$\sqrt{3}$	1	$\pm 1.501 \%$	$\infty$
RF Ambient Conditions	$\pm 3.0$	Rectangular	$\sqrt{3}$	1	$\pm 1.732 \%$	$\infty$
Probe Positioner	$\pm 0.4$	Rectangular	$\sqrt{3}$	1	$\pm 0.231 \%$	$\infty$
Probe Positioning	$\pm 2.9$	Rectangular	$\sqrt{3}$	1	$\pm 1.674 \%$	$\infty$
Algorithms for Max. SAR Eval.	$\pm 1.0$	Rectangular	$\sqrt{3}$	1	$\pm 0.577 \%$	$\infty$
<b>Test Sample Related</b>						
Device Positioning	$\pm 2.9$	Normal	1	1	$\pm 2.9 \%$	145
Device Holder	$\pm 3.6$	Normal	1	1	$\pm 3.6 \%$	5
Power Drift	$\pm 5.0$	Rectangular	$\sqrt{3}$	1	$\pm 2.887 \%$	$\infty$
<b>Physical Parameters</b>						
Phantom Shell	$\pm 4.0$	Rectangular	$\sqrt{3}$	1	$\pm 2.31 \%$	$\infty$
Liquid conductivity (Target)	$\pm 5.0$	Rectangular	$\sqrt{3}$	0.64	$\pm 2.887 \%$	$\infty$
Liquid conductivity (Meas.)	$\pm 3.7$	Normal	1	0.64	$\pm 3.7 \%$	$\infty$
Liquid permittivity (Target)	$\pm 5.0$	Rectangular	$\sqrt{3}$	0.6	$\pm 2.887 \%$	$\infty$
Liquid permittivity (Meas.)	$\pm 4.5$	Normal	1	0.6	$\pm 4.5 \%$	$\infty$
<b>Combined Standard Uncertainty</b>					<b><math>\pm 12.1 \%</math></b>	<b>330</b>
<b>Expanded Uncertainty (k=2)</b>					<b><math>\pm 24.2 \%</math></b>	

The above measurement uncertainties are according to IEEE P1528 (2003)

**2450 MHz Head**

Error Description	Uncertainty value $\pm\%$	Probability Distribution	Divisor	(Ci) 1g	Standard (1g)	vi 2 or Veff
<b>Measurement System</b>						
Probe calibration	$\pm 6.0$	Normal	1	1	$\pm 6.0 \%$	$\infty$
Axial isotropy	$\pm 4.7$	Rectangular	$\sqrt{3}$	1	$\pm 2.714 \%$	$\infty$
Hemispherical isotropy	$\pm 9.6$	Rectangular	$\sqrt{3}$	1	$\pm 5.543 \%$	$\infty$
Boundary Effects	$\pm 0.8$	Rectangular	$\sqrt{3}$	1	$\pm 0.462 \%$	$\infty$
Probe Linearity	$\pm 4.7$	Rectangular	$\sqrt{3}$	1	$\pm 2.714 \%$	$\infty$
Detection limits	$\pm 0.25$	Rectangular	$\sqrt{3}$	1	$\pm 0.145 \%$	$\infty$
Readout Electronics	$\pm 1.0$	Normal	1	1	$\pm 1.0 \%$	$\infty$
Response time	$\pm 0.8$	Rectangular	$\sqrt{3}$	1	$\pm 0.462 \%$	$\infty$
Integration time	$\pm 2.6$	Rectangular	$\sqrt{3}$	1	$\pm 1.501 \%$	$\infty$
RF Ambient Conditions	$\pm 3.0$	Rectangular	$\sqrt{3}$	1	$\pm 1.732 \%$	$\infty$
Probe Positioner	$\pm 0.4$	Rectangular	$\sqrt{3}$	1	$\pm 0.231 \%$	$\infty$
Probe Positioning	$\pm 2.9$	Rectangular	$\sqrt{3}$	1	$\pm 1.674 \%$	$\infty$
Algorithms for Max. SAR Eval.	$\pm 1.0$	Rectangular	$\sqrt{3}$	1	$\pm 0.577 \%$	$\infty$
<b>Test Sample Related</b>						
Device Positioning	$\pm 2.9$	Normal	1	1	$\pm 2.9 \%$	145
Device Holder	$\pm 3.6$	Normal	1	1	$\pm 3.6 \%$	5
Power Drift	$\pm 5.0$	Rectangular	$\sqrt{3}$	1	$\pm 2.887 \%$	$\infty$
<b>Physical Parameters</b>						
Phantom Shell	$\pm 4.0$	Rectangular	$\sqrt{3}$	1	$\pm 2.31 \%$	$\infty$
Liquid conductivity (Target)	$\pm 5.0$	Rectangular	$\sqrt{3}$	0.64	$\pm 2.887 \%$	$\infty$
Liquid conductivity (Meas.)	$\pm 4.4$	Normal	1	0.64	$\pm 4.4 \%$	$\infty$
Liquid permittivity (Target)	$\pm 5.0$	Rectangular	$\sqrt{3}$	0.6	$\pm 2.887 \%$	$\infty$
Liquid permittivity (Meas.)	$\pm 4.6$	Normal	1	0.6	$\pm 4.6 \%$	$\infty$
<b>Combined Standard Uncertainty</b>					<b><math>\pm 12.2 \%</math></b>	<b>330</b>
<b>Expanded Uncertainty (k=2)</b>					<b><math>\pm 24.4 \%</math></b>	

The above measurement uncertainties are according to IEEE P1528 (2003)

**2450 MHz Body**

Error Description	Uncertainty value $\pm\%$	Probability Distribution	Divisor	(Ci) 1g	Standard (1g)	vi 2 or Veff
<b>Measurement System</b>						
Probe calibration	$\pm 6.0$	Normal	1	1	$\pm 6.0 \%$	$\infty$
Axial isotropy	$\pm 4.7$	Rectangular	$\sqrt{3}$	1	$\pm 2.714 \%$	$\infty$
Hemispherical isotropy	$\pm 9.6$	Rectangular	$\sqrt{3}$	1	$\pm 5.543 \%$	$\infty$
Boundary Effects	$\pm 0.8$	Rectangular	$\sqrt{3}$	1	$\pm 0.462 \%$	$\infty$
Probe Linearity	$\pm 4.7$	Rectangular	$\sqrt{3}$	1	$\pm 2.714 \%$	$\infty$
Detection limits	$\pm 0.25$	Rectangular	$\sqrt{3}$	1	$\pm 0.145 \%$	$\infty$
Readout Electronics	$\pm 1.0$	Normal	1	1	$\pm 1.0 \%$	$\infty$
Response time	$\pm 0.8$	Rectangular	$\sqrt{3}$	1	$\pm 0.462 \%$	$\infty$
Integration time	$\pm 2.6$	Rectangular	$\sqrt{3}$	1	$\pm 1.501 \%$	$\infty$
RF Ambient Conditions	$\pm 3.0$	Rectangular	$\sqrt{3}$	1	$\pm 1.732 \%$	$\infty$
Probe Positioner	$\pm 0.4$	Rectangular	$\sqrt{3}$	1	$\pm 0.231 \%$	$\infty$
Probe Positioning	$\pm 2.9$	Rectangular	$\sqrt{3}$	1	$\pm 1.674 \%$	$\infty$
Algorithms for Max. SAR Eval.	$\pm 1.0$	Rectangular	$\sqrt{3}$	1	$\pm 0.577 \%$	$\infty$
<b>Test Sample Related</b>						
Device Positioning	$\pm 2.9$	Normal	1	1	$\pm 2.9 \%$	145
Device Holder	$\pm 3.6$	Normal	1	1	$\pm 3.6 \%$	5
Power Drift	$\pm 5.0$	Rectangular	$\sqrt{3}$	1	$\pm 2.887 \%$	$\infty$
<b>Physical Parameters</b>						
Phantom Shell	$\pm 4.0$	Rectangular	$\sqrt{3}$	1	$\pm 2.31 \%$	$\infty$
Liquid conductivity (Target)	$\pm 5.0$	Rectangular	$\sqrt{3}$	0.64	$\pm 2.887 \%$	$\infty$
Liquid conductivity (Meas.)	$\pm 4.1$	Normal	1	0.64	$\pm 4.1 \%$	$\infty$
Liquid permittivity (Target)	$\pm 5.0$	Rectangular	$\sqrt{3}$	0.6	$\pm 2.887 \%$	$\infty$
Liquid permittivity (Meas.)	$\pm 4.5$	Normal	1	0.6	$\pm 4.5 \%$	$\infty$
<b>Combined Standard Uncertainty</b>					<b><math>\pm 12.1 \%</math></b>	<b>330</b>
<b>Expanded Uncertainty (k=2)</b>					<b><math>\pm 24.2 \%</math></b>	

The above measurement uncertainties are according to IEEE P1528 (2003)

**5300 MHz Head**

Error Description	Uncertainty value $\pm\%$	Probability Distribution	Divisor	(Ci) 1g	Standard (1g)	vi 2 or Veff
<b>Measurement System</b>						
Probe calibration	$\pm 6.55$	Normal	1	1	$\pm 6.55 \%$	$\infty$
Axial isotropy	$\pm 4.7$	Rectangular	$\sqrt{3}$	1	$\pm 2.714 \%$	$\infty$
Hemispherical isotropy	$\pm 9.6$	Rectangular	$\sqrt{3}$	1	$\pm 5.543 \%$	$\infty$
Boundary Effects	$\pm 0.8$	Rectangular	$\sqrt{3}$	1	$\pm 0.462 \%$	$\infty$
Probe Linearity	$\pm 4.7$	Rectangular	$\sqrt{3}$	1	$\pm 2.714 \%$	$\infty$
Detection limits	$\pm 0.25$	Rectangular	$\sqrt{3}$	1	$\pm 0.145 \%$	$\infty$
Readout Electronics	$\pm 1.0$	Normal	1	1	$\pm 1.0 \%$	$\infty$
Response time	$\pm 0.8$	Rectangular	$\sqrt{3}$	1	$\pm 0.462 \%$	$\infty$
Integration time	$\pm 2.6$	Rectangular	$\sqrt{3}$	1	$\pm 1.501 \%$	$\infty$
RF Ambient Conditions	$\pm 3.0$	Rectangular	$\sqrt{3}$	1	$\pm 1.732 \%$	$\infty$
Probe Positioner	$\pm 0.4$	Rectangular	$\sqrt{3}$	1	$\pm 0.231 \%$	$\infty$
Probe Positioning	$\pm 2.9$	Rectangular	$\sqrt{3}$	1	$\pm 1.674 \%$	$\infty$
Algorithms for Max. SAR Eval.	$\pm 1.0$	Rectangular	$\sqrt{3}$	1	$\pm 0.577 \%$	$\infty$
<b>Test Sample Related</b>						
Device Positioning	$\pm 2.9$	Normal	1	1	$\pm 2.9 \%$	145
Device Holder	$\pm 3.6$	Normal	1	1	$\pm 3.6 \%$	5
Power Drift	$\pm 5.0$	Rectangular	$\sqrt{3}$	1	$\pm 2.887 \%$	$\infty$
<b>Physical Parameters</b>						
Phantom Shell	$\pm 4.0$	Rectangular	$\sqrt{3}$	1	$\pm 2.31 \%$	$\infty$
Liquid conductivity (Target)	$\pm 5.0$	Rectangular	$\sqrt{3}$	0.64	$\pm 2.887 \%$	$\infty$
Liquid conductivity (Meas.)	$\pm 3.7$	Normal	1	0.64	$\pm 3.7 \%$	$\infty$
Liquid permittivity (Target)	$\pm 5.0$	Rectangular	$\sqrt{3}$	0.6	$\pm 2.887 \%$	$\infty$
Liquid permittivity (Meas.)	$\pm 4.6$	Normal	1	0.6	$\pm 4.6 \%$	$\infty$
<b>Combined Standard Uncertainty</b>					<b><math>\pm 12.4 \%</math></b>	<b>330</b>
<b>Expanded Uncertainty (k=2)</b>					<b><math>\pm 24.8 \%</math></b>	

The above measurement uncertainties are according to IEEE P1528 (2003)

**5600 MHz Head**

Error Description	Uncertainty value $\pm\%$	Probability Distribution	Divisor	(Ci) 1g	Standard (1g)	vi 2 or Veff
<b>Measurement System</b>						
Probe calibration	$\pm 6.55$	Normal	1	1	$\pm 6.55 \%$	$\infty$
Axial isotropy	$\pm 4.7$	Rectangular	$\sqrt{3}$	1	$\pm 2.714 \%$	$\infty$
Hemispherical isotropy	$\pm 9.6$	Rectangular	$\sqrt{3}$	1	$\pm 5.543 \%$	$\infty$
Boundary Effects	$\pm 0.8$	Rectangular	$\sqrt{3}$	1	$\pm 0.462 \%$	$\infty$
Probe Linearity	$\pm 4.7$	Rectangular	$\sqrt{3}$	1	$\pm 2.714 \%$	$\infty$
Detection limits	$\pm 0.25$	Rectangular	$\sqrt{3}$	1	$\pm 0.145 \%$	$\infty$
Readout Electronics	$\pm 1.0$	Normal	1	1	$\pm 1.0 \%$	$\infty$
Response time	$\pm 0.8$	Rectangular	$\sqrt{3}$	1	$\pm 0.462 \%$	$\infty$
Integration time	$\pm 2.6$	Rectangular	$\sqrt{3}$	1	$\pm 1.501 \%$	$\infty$
RF Ambient Conditions	$\pm 3.0$	Rectangular	$\sqrt{3}$	1	$\pm 1.732 \%$	$\infty$
Probe Positioner	$\pm 0.4$	Rectangular	$\sqrt{3}$	1	$\pm 0.231 \%$	$\infty$
Probe Positioning	$\pm 2.9$	Rectangular	$\sqrt{3}$	1	$\pm 1.674 \%$	$\infty$
Algorithms for Max. SAR Eval.	$\pm 1.0$	Rectangular	$\sqrt{3}$	1	$\pm 0.577 \%$	$\infty$
<b>Test Sample Related</b>						
Device Positioning	$\pm 2.9$	Normal	1	1	$\pm 2.9 \%$	145
Device Holder	$\pm 3.6$	Normal	1	1	$\pm 3.6 \%$	5
Power Drift	$\pm 5.0$	Rectangular	$\sqrt{3}$	1	$\pm 2.887 \%$	$\infty$
<b>Physical Parameters</b>						
Phantom Shell	$\pm 4.0$	Rectangular	$\sqrt{3}$	1	$\pm 2.31 \%$	$\infty$
Liquid conductivity (Target)	$\pm 5.0$	Rectangular	$\sqrt{3}$	0.64	$\pm 2.887 \%$	$\infty$
Liquid conductivity (Meas.)	$\pm 3.9$	Normal	1	0.64	$\pm 3.9 \%$	$\infty$
Liquid permittivity (Target)	$\pm 5.0$	Rectangular	$\sqrt{3}$	0.6	$\pm 2.887 \%$	$\infty$
Liquid permittivity (Meas.)	$\pm 4.5$	Normal	1	0.6	$\pm 4.5 \%$	$\infty$
<b>Combined Standard Uncertainty</b>					<b><math>\pm 12.4 \%</math></b>	<b>330</b>
<b>Expanded Uncertainty (k=2)</b>					<b><math>\pm 24.8 \%</math></b>	

The above measurement uncertainties are according to IEEE P1528 (2003)



**5800 MHz Head**

Error Description	Uncertainty value $\pm\%$	Probability Distribution	Divisor	(Ci) 1g	Standard (1g)	vi 2 or Veff
<b>Measurement System</b>						
Probe calibration	$\pm 6.55$	Normal	1	1	$\pm 6.55 \%$	$\infty$
Axial isotropy	$\pm 4.7$	Rectangular	$\sqrt{3}$	1	$\pm 2.714 \%$	$\infty$
Hemispherical isotropy	$\pm 9.6$	Rectangular	$\sqrt{3}$	1	$\pm 5.543 \%$	$\infty$
Boundary Effects	$\pm 0.8$	Rectangular	$\sqrt{3}$	1	$\pm 0.462 \%$	$\infty$
Probe Linearity	$\pm 4.7$	Rectangular	$\sqrt{3}$	1	$\pm 2.714 \%$	$\infty$
Detection limits	$\pm 0.25$	Rectangular	$\sqrt{3}$	1	$\pm 0.145 \%$	$\infty$
Readout Electronics	$\pm 1.0$	Normal	1	1	$\pm 1.0 \%$	$\infty$
Response time	$\pm 0.8$	Rectangular	$\sqrt{3}$	1	$\pm 0.462 \%$	$\infty$
Integration time	$\pm 2.6$	Rectangular	$\sqrt{3}$	1	$\pm 1.501 \%$	$\infty$
RF Ambient Conditions	$\pm 3.0$	Rectangular	$\sqrt{3}$	1	$\pm 1.732 \%$	$\infty$
Probe Positioner	$\pm 0.4$	Rectangular	$\sqrt{3}$	1	$\pm 0.231 \%$	$\infty$
Probe Positioning	$\pm 2.9$	Rectangular	$\sqrt{3}$	1	$\pm 1.674 \%$	$\infty$
Algorithms for Max. SAR Eval.	$\pm 1.0$	Rectangular	$\sqrt{3}$	1	$\pm 0.577 \%$	$\infty$
<b>Test Sample Related</b>						
Device Positioning	$\pm 2.9$	Normal	1	1	$\pm 2.9 \%$	145
Device Holder	$\pm 3.6$	Normal	1	1	$\pm 3.6 \%$	5
Power Drift	$\pm 5.0$	Rectangular	$\sqrt{3}$	1	$\pm 2.887 \%$	$\infty$
<b>Physical Parameters</b>						
Phantom Shell	$\pm 4.0$	Rectangular	$\sqrt{3}$	1	$\pm 2.31 \%$	$\infty$
Liquid conductivity (Target)	$\pm 5.0$	Rectangular	$\sqrt{3}$	0.64	$\pm 2.887 \%$	$\infty$
Liquid conductivity (Meas.)	$\pm 4.4$	Normal	1	0.64	$\pm 4.4 \%$	$\infty$
Liquid permittivity (Target)	$\pm 5.0$	Rectangular	$\sqrt{3}$	0.6	$\pm 2.887 \%$	$\infty$
Liquid permittivity (Meas.)	$\pm 4.0$	Normal	1	0.6	$\pm 4.0 \%$	$\infty$
<b>Combined Standard Uncertainty</b>					<b><math>\pm 12.4 \%</math></b>	<b>330</b>
<b>Expanded Uncertainty (k=2)</b>					<b><math>\pm 24.8 \%</math></b>	

The above measurement uncertainties are according to IEEE P1528 (2003)

---

## 16. CONCLUSION

---

### Measurement Conclusion

The SAR measurement indicates that the EUT complies with the RF radiation exposure limits of the FCC. These measurements are taken to simulate the RF effects exposure under the worst-case conditions. Precise laboratory measures were taken to assure repeatability of the tests. The tested device complies with the requirements in respect to all parameters subject to the test. The test results and statements relate only to the item(s) tested.

Please note that the absorption and distribution of electromagnetic energy in the body are every complex phenomena that depend on the mass, shape, and size of the body, the orientation of the body with respect to the field vectors, and the electrical properties of both the body and the environment. Other variables that may play a substantial role impossible biological effect are those that characterize the environment (e.g. ambient temperature, air velocity, relative humidity, and body insulation) and those that characterize the individual (e.g. age, gender, activity level, debilitation, or disease).

Because innumerable factors may interact to determine the specific biological outcome of an exposure to electromagnetic fields, any protection guide shall consider maximal amplification of biological effects as a result of field-body interactions, environmental conditions, and physiological variables.

## 17. REFERENCES

---

- [1] Federal Communications Commission, ET Docket 93-62, Guidelines for Evaluating the Environmental Effects of Radiofrequency Radiation, Aug. 1996.
- [2] ANSI/IEEE C95.1-2005, American National Standard safety levels with respect to human exposure to radiofrequency electromagnetic fields, 3kHz to 300GHz, New York: IEEE, 2006.
- [3] ANSI/IEEE C95.1-1992, American National Standard safety levels with respect to human exposure to radiofrequency electromagnetic fields, 3kHz to 300GHz, New York: IEEE, Sept. 1992.
- [4] ANSI/IEEE C95.3-2002, IEEE Recommended Practice for the Measurement of Potentially Hazardous Electromagnetic Fields - RF and Microwave, New York: IEEE, December 2002.
- [5] IEEE Standards Coordinating Committee 39 – IEEE Std. 1528-2013, Recommended Practice for Determining the Peak Spatial-Average Specific Absorption Rate (SAR) in the Human Head from Wireless Communications Devices.
- [6] NCRP, National Council on Radiation Protection and Measurements, Biological Effects and Exposure Criteria for Radio Frequency Electromagnetic Fields, NCRP Report No. 86, 1986. Reprinted Feb. 1995.
- [7] T. Schmid, O. Egger, N. Kuster, Automated E-field scanning system for dosimetric assessments, IEEE Transaction on Microwave Theory and Techniques, vol. 44, Jan. 1996, pp. 105-113.
- [8] K. Pokovic, T. Schmid, N. Kuster, Robust setup for precise calibration of E-field probes in tissue simulating liquids at mobile communications frequencies, ICECOM97, Oct. 1997, pp. -124.
- [9] K. Pokovic, T. Schmid, and N. Kuster, E-field Probe with improved isotropy in brain simulating liquids, Proceedings of the ELMAR, Zadar, Croatia, June 23-25, 1996, pp. 172-175.
- [10] Schmid & Partner Engineering AG, Application Note: Data Storage and Evaluation, June 1998, p2.
- [11] V. Hombach, K. Meier, M. Burkhardt, E. Kuhn, N. Kuster, The Dependence of EM Energy Absorption upon Human Modeling at 900 MHz, IEEE Transaction on Microwave Theory and Techniques, vol. 44 no. 10, Oct. 1996, pp. 1865-1873.
- [12] N. Kuster and Q. Balzano, Energy absorption mechanism by biological bodies in the near field of dipole antennas above 300MHz, IEEE Transaction on Vehicular Technology, vol. 41, no. 1, Feb. 1992, pp. 17-23.
- [13] G. Hartsgrove, A. Kraszewski, A. Surowiec, Simulated Biological Materials for Electromagnetic Radiation Absorption Studies, University of Ottawa, Bio electromagnetics, Canada: 1987, pp. 29-36.
- [14] Q. Balzano, O. Garay, T. Manning Jr., Electromagnetic Energy Exposure of Simulated Users of Portable Cellular Telephones, IEEE Transactions on Vehicular Technology, vol. 44, no.3, Aug. 1995.
- [15] W. Gander, Computer mathematick, Birkhaeuser, Basel, 1992.
- [16] W.H. Press, S.A. Teukolsky, W.T. Vetterling, and B.P. Flannery, Numerical Recipes in C, The Art of Scientific Computing, Second edition, Cambridge University Press, 1992.
- [17] N. Kuster, R. Kastle, T. Schmid, Dosimetric evaluation of mobile communications equipment with known precision, IEEE Transaction on Communications, vol. E80-B, no. 5, May 1997, pp. 645-652.
- [18] CENELEC CLC/SC111B, European Prestandard (prENV 50166-2), Human Exposure to Electromagnetic Fields High-frequency: 10kHz-300GHz, Jan. 1995.
- [19] Prof. Dr. Niels Kuster, ETH, Eidgenössische Technische Hochschule Zürich, Dosimetric Evaluation of the Cellular Phone.

- [20] IEC 62209-1, Human exposure to radio frequency fields from hand-held and body-mounted wireless communication devices - Human models, instrumentation, and procedures - Part 1: Procedure to determine the specific absorption rate (SAR) for hand-held devices used in close proximity to the ear (frequency range of 300MHz to 3 GHz), Feb. 2005.
- [21] Industry Canada RSS-102 Radio Frequency Exposure Compliance of Radio communication Apparatus (All Frequency Bands) Issue 4, March 2010.
- [22] Health Canada Safety Code 6 Limits of Human Exposure to Radio Frequency Electromagnetic Fields in the Frequency Range from 3 kHz – 300 GHz, 2009
- [23] FCC SAR Test Procedures for 2G-3G Devices, Mobile Hotspot and UMPC Devices KDB Publications 941225, D01-D07
- [24] SAR Measurement procedures for IEEE 802.11a/b/g KDB Publication 248227 D01v02r02
- [25] FCC SAR Considerations for Handsets with Multiple Transmitters and Antennas, KDB Publications 648474 D03-D04
- [26] FCC SAR Evaluation Considerations for Laptop, Notebook, Netbook and Tablet Computers, FCC KDB Publication 616217 D04
- [27] FCC SAR Measurement and Reporting Requirements for 100MHz – 6 GHz, KDB Publications 865664 D01-D02
- [28] FCC General RF Exposure Guidance and SAR Procedures for Dongles, KDB Publication 447498, D01-D02
- [29] 615223 D01 802 16e WI-Max SAR Guidance v01, Nov. 13, 2009
- [30] Anexo à Resolução No. 533, de 10 de September de 2009.
- [31] IEC 62209-2, Human exposure to radio frequency fields from hand-held and body-mounted wireless communication devices - Human models, instrumentation, and procedures - Part 2: Procedure to determine the specific absorption rate (SAR) for wireless communication devices used in close proximity to the human body(frequency range of 30 MHz to 6 GHz), Mar. 2010.



---

## Attachment 1. – Probe Calibration Data

**Calibration Laboratory of  
Schmid & Partner  
Engineering AG**  
Zeughausstrasse 43, 8004 Zurich, Switzerland



**S** Schweizerischer Kalibrierdienst  
**C** Service suisse d'étalonnage  
**S** Servizio svizzero di taratura  
**S** Swiss Calibration Service

Accredited by the Swiss Accreditation Service (SAS)  
The Swiss Accreditation Service is one of the signatories to the EA  
Multilateral Agreement for the recognition of calibration certificates

Accreditation No.: **SCS 0108**

Client **DT&C (Dymstec)**

Certificate No: **EX3-3866\_May15**

### CALIBRATION CERTIFICATE

Object: **EX3DV4 - SN:3866**

Calibration procedure(s): **QA CAL-01.v9, QA CAL-12.v9, QA CAL-14.v4, QA CAL-23.v5,  
QA CAL-25.v6  
Calibration procedure for dosimetric E-field probes**



Calibration date: **May 27, 2015**

This calibration certificate documents the traceability to national standards, which realize the physical units of measurements (SI).  
The measurements and the uncertainties with confidence probability are given on the following pages and are part of the certificate.

All calibrations have been conducted in the closed laboratory facility: environment temperature (22 ± 3)°C and humidity < 70%.

Calibration Equipment used (M&TE critical for calibration)

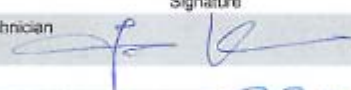
Primary Standards	ID	Cal Date (Certificate No.)	Scheduled Calibration
Power meter E4419B	GB41293874	01-Apr-15 (No. 217-02128)	Mar-16
Power sensor E4412A	MY41498087	01-Apr-15 (No. 217-02128)	Mar-16
Reference 3 dB Attenuator	SN: S5054 (3c)	01-Apr-15 (No. 217-02129)	Mar-16
Reference 20 dB Attenuator	SN: S5277 (20x)	01-Apr-15 (No. 217-02132)	Mar-16
Reference 30 dB Attenuator	SN: S5129 (30b)	01-Apr-15 (No. 217-02133)	Mar-16
Reference Probe ES3DV2	SN: 3013	30-Dec-14 (No. ES3-3013_Dec14)	Dec-15
DAE4	SN: 660	14-Jan-15 (No. DAE4-660_Jan15)	Jan-16
Secondary Standards	ID	Check Date (in house)	Scheduled Check
RF generator HP 8648C	US3642U01700	4-Aug-99 (in house check Apr-13)	In house check: Apr-16
Network Analyzer HP 8753E	US37390585	18-Oct-01 (in house check Oct-14)	In house check: Oct-15

Calibrated by:	Name <b>Jeton Kastrati</b>	Function <b>Laboratory Technician</b>	Signature 
Approved by:	Name <b>Katja Pokovic</b>	Function <b>Technical Manager</b>	Signature 

Issued: May 28, 2015

This calibration certificate shall not be reproduced except in full without written approval of the laboratory.

**Calibration Laboratory of  
Schmid & Partner  
Engineering AG**  
Zeughausstrasse 43, 8004 Zurich, Switzerland



**S** Schweizerischer Kalibrierdienst  
**C** Service suisse d'étalonnage  
**S** Servizio svizzero di taratura  
**S** Swiss Calibration Service

Accredited by the Swiss Accreditation Service (SAS)  
The Swiss Accreditation Service is one of the signatories to the EA  
Multilateral Agreement for the recognition of calibration certificates

Accreditation No.: SCS 0108

### Glossary:

TSL	tissue simulating liquid
NORM <sub>x,y,z</sub>	sensitivity in free space
ConvF	sensitivity in TSL / NORM <sub>x,y,z</sub>
DCP	diode compression point
CF	crest factor (1/duty_cycle) of the RF signal
A, B, C, D	modulation dependent linearization parameters
Polarization $\varphi$	$\varphi$ rotation around probe axis
Polarization $\vartheta$	$\vartheta$ rotation around an axis that is in the plane normal to probe axis (at measurement center), i.e., $\vartheta = 0$ is normal to probe axis
Connector Angle	information used in DASY system to align probe sensor X to the robot coordinate system

### Calibration is Performed According to the Following Standards:

- IEEE Std 1528-2013, "IEEE Recommended Practice for Determining the Peak Spatial-Averaged Specific Absorption Rate (SAR) in the Human Head from Wireless Communications Devices: Measurement Techniques", June 2013
- IEC 62209-1, "Procedure to measure the Specific Absorption Rate (SAR) for hand-held devices used in close proximity to the ear (frequency range of 300 MHz to 3 GHz)", February 2005

### Methods Applied and Interpretation of Parameters:

- NORM<sub>x,y,z</sub>**: Assessed for E-field polarization  $\vartheta = 0$  ( $f \leq 900$  MHz in TEM-cell;  $f > 1800$  MHz: R22 waveguide). NORM<sub>x,y,z</sub> are only intermediate values, i.e., the uncertainties of NORM<sub>x,y,z</sub> does not affect the E<sup>2</sup>-field uncertainty inside TSL (see below ConvF).
- NORM(f)<sub>x,y,z</sub> = NORM<sub>x,y,z</sub> \* frequency\_response** (see Frequency Response Chart). This linearization is implemented in DASY4 software versions later than 4.2. The uncertainty of the frequency response is included in the stated uncertainty of ConvF.
- DCP<sub>x,y,z</sub>**: DCP are numerical linearization parameters assessed based on the data of power sweep with CW signal (no uncertainty required). DCP does not depend on frequency nor media.
- PAR**: PAR is the Peak to Average Ratio that is not calibrated but determined based on the signal characteristics
- A<sub>x,y,z</sub>; B<sub>x,y,z</sub>; C<sub>x,y,z</sub>; D<sub>x,y,z</sub>; VR<sub>x,y,z</sub>; A, B, C, D** are numerical linearization parameters assessed based on the data of power sweep for specific modulation signal. The parameters do not depend on frequency nor media. VR is the maximum calibration range expressed in RMS voltage across the diode.
- ConvF and Boundary Effect Parameters**: Assessed in flat phantom using E-field (or Temperature Transfer Standard for  $f \leq 800$  MHz) and inside waveguide using analytical field distributions based on power measurements for  $f > 800$  MHz. The same setups are used for assessment of the parameters applied for boundary compensation (alpha, depth) of which typical uncertainty values are given. These parameters are used in DASY4 software to improve probe accuracy close to the boundary. The sensitivity in TSL corresponds to NORM<sub>x,y,z</sub> \* ConvF whereby the uncertainty corresponds to that given for ConvF. A frequency dependent ConvF is used in DASY version 4.4 and higher which allows extending the validity from  $\pm 50$  MHz to  $\pm 100$  MHz.
- Spherical isotropy (3D deviation from isotropy)**: in a field of low gradients realized using a flat phantom exposed by a patch antenna.
- Sensor Offset**: The sensor offset corresponds to the offset of virtual measurement center from the probe tip (on probe axis). No tolerance required.
- Connector Angle**: The angle is assessed using the information gained by determining the NORM<sub>x</sub> (no uncertainty required).

EX3DV4 – SN:3866

May 27, 2015

# Probe EX3DV4

## SN:3866

Manufactured: February 2, 2012  
Calibrated: May 27, 2015

Calibrated for DASY/EASY Systems  
(Note: non-compatible with DASY2 system!)



EX3DV4- SN:3866

May 27, 2015

## DASY/EASY - Parameters of Probe: EX3DV4 - SN:3866

### Basic Calibration Parameters

	Sensor X	Sensor Y	Sensor Z	Unc (k=2)
Norm ( $\mu\text{V}/(\text{V}/\text{m})^2$ ) <sup>A</sup>	0.42	0.46	0.40	$\pm 10.1 \%$
DCP (mV) <sup>B</sup>	101.2	101.7	102.6	

### Modulation Calibration Parameters

UID	Communication System Name		A dB	B dB $\sqrt{\mu\text{V}}$	C	D dB	VR mV	Unc <sup>E</sup> (k=2)
0	CW	X	0.0	0.0	1.0	0.00	145.9	$\pm 3.8 \%$
		Y	0.0	0.0	1.0		130.9	
		Z	0.0	0.0	1.0		136.9	

The reported uncertainty of measurement is stated as the standard uncertainty of measurement multiplied by the coverage factor k=2, which for a normal distribution corresponds to a coverage probability of approximately 95%.

<sup>A</sup> The uncertainties of NormX,Y,Z do not affect the E<sup>2</sup>-field uncertainty inside TSL (see Pages 5 and 6).

<sup>B</sup> Numerical linearization parameter: uncertainty not required.

<sup>E</sup> Uncertainty is determined using the max. deviation from linear response applying rectangular distribution and is expressed for the square of the field value.

EX3DV4-- SN:3866

May 27, 2015

## DASY/EASY - Parameters of Probe: EX3DV4 - SN:3866

### Calibration Parameter Determined in Head Tissue Simulating Media

f (MHz) <sup>C</sup>	Relative Permittivity <sup>F</sup>	Conductivity (S/m) <sup>F</sup>	ConvF X	ConvF Y	ConvF Z	Alpha <sup>G</sup>	Depth <sup>G</sup> (mm)	Unct. (k=2)
300	45.3	0.87	10.94	10.94	10.94	0.10	1.15	± 13.3 %
450	43.5	0.87	11.20	11.20	11.20	0.18	1.20	± 13.3 %
600	42.7	0.88	9.99	9.99	9.99	0.08	1.15	± 13.3 %
750	41.9	0.89	9.54	9.54	9.54	0.25	1.20	± 12.0 %
835	41.5	0.90	9.09	9.09	9.09	0.18	1.68	± 12.0 %
900	41.5	0.97	8.93	8.93	8.93	0.24	1.37	± 12.0 %
1750	40.1	1.37	7.84	7.84	7.84	0.39	0.81	± 12.0 %
1900	40.0	1.40	7.58	7.58	7.58	0.26	0.98	± 12.0 %
2300	39.5	1.67	7.20	7.20	7.20	0.34	0.80	± 12.0 %
2450	39.2	1.80	6.85	6.85	6.85	0.25	1.09	± 12.0 %
2600	39.0	1.96	6.73	6.73	6.73	0.23	1.17	± 12.0 %
3500	37.9	2.91	6.58	6.58	6.58	0.21	1.79	± 13.1 %
5200	36.0	4.66	5.24	5.24	5.24	0.35	1.80	± 13.1 %
5300	35.9	4.76	5.02	5.02	5.02	0.35	1.80	± 13.1 %
5500	35.6	4.96	4.50	4.50	4.50	0.40	1.80	± 13.1 %
5600	35.5	5.07	4.33	4.33	4.33	0.40	1.80	± 13.1 %
5800	35.3	5.27	4.57	4.57	4.57	0.40	1.80	± 13.1 %

<sup>C</sup> Frequency validity above 300 MHz of ± 100 MHz only applies for DASY v4.4 and higher (see Page 2), else it is restricted to ± 50 MHz. The uncertainty is the RSS of the ConvF uncertainty at calibration frequency and the uncertainty for the indicated frequency band. Frequency validity below 300 MHz is ± 10, 25, 40, 50 and 70 MHz for ConvF assessments at 30, 64, 128, 150 and 220 MHz respectively. Above 5 GHz frequency validity can be extended to ± 110 MHz.

<sup>F</sup> At frequencies below 3 GHz, the validity of tissue parameters ( $\epsilon$  and  $\sigma$ ) can be relaxed to ± 10% if liquid compensation formula is applied to measured SAR values. At frequencies above 3 GHz, the validity of tissue parameters ( $\epsilon$  and  $\sigma$ ) is restricted to ± 5%. The uncertainty is the RSS of the ConvF uncertainty for indicated target tissue parameters.

<sup>G</sup> Alpha/Depth are determined during calibration. SPEAG warrants that the remaining deviation due to the boundary effect after compensation is always less than ± 1% for frequencies below 3 GHz and below ± 2% for frequencies between 3-6 GHz at any distance larger than half the probe tip diameter from the boundary.

EX3DV4- SN:3866

May 27, 2015

## DASY/EASY - Parameters of Probe: EX3DV4 - SN:3866

### Calibration Parameter Determined in Body Tissue Simulating Media

f (MHz) <sup>c</sup>	Relative Permittivity <sup>f</sup>	Conductivity (S/m) <sup>f</sup>	ConvF X	ConvF Y	ConvF Z	Alpha <sup>g</sup>	Depth <sup>g</sup> (mm)	Unct. (k=2)
300	58.2	0.92	10.73	10.73	10.73	0.06	1.15	± 13.3 %
450	56.7	0.94	10.60	10.60	10.60	0.10	1.15	± 13.3 %
600	56.1	0.95	10.02	10.02	10.02	0.05	1.15	± 13.3 %
750	55.5	0.96	9.39	9.39	9.39	0.43	0.80	± 12.0 %
835	55.2	0.97	9.25	9.25	9.25	0.51	0.84	± 12.0 %
900	55.0	1.05	9.12	9.12	9.12	0.33	1.06	± 12.0 %
1750	53.4	1.49	7.64	7.64	7.64	0.44	0.80	± 12.0 %
1900	53.3	1.52	7.31	7.31	7.31	0.42	0.80	± 12.0 %
2300	52.9	1.81	7.15	7.15	7.15	0.38	0.80	± 12.0 %
2450	52.7	1.95	7.00	7.00	7.00	0.36	0.80	± 12.0 %
2600	52.5	2.16	6.84	6.84	6.84	0.29	0.80	± 12.0 %
3500	51.3	3.31	6.18	6.18	6.18	0.22	2.07	± 13.1 %
5200	49.0	5.30	4.28	4.28	4.28	0.40	1.90	± 13.1 %
5300	48.9	5.42	4.21	4.21	4.21	0.40	1.90	± 13.1 %
5500	48.6	5.65	3.90	3.90	3.90	0.45	1.90	± 13.1 %
5600	48.5	5.77	3.83	3.83	3.83	0.45	1.90	± 13.1 %
5800	48.2	6.00	4.02	4.02	4.02	0.45	1.90	± 13.1 %

<sup>c</sup> Frequency validity above 300 MHz of ± 100 MHz only applies for DASY v4.4 and higher (see Page 2), else it is restricted to ± 50 MHz. The uncertainty is the RSS of the ConvF uncertainty at calibration frequency and the uncertainty for the indicated frequency band. Frequency validity below 300 MHz is ± 10, 25, 40, 50 and 70 MHz for ConvF assessments at 30, 64, 128, 150 and 220 MHz respectively. Above 5 GHz frequency validity can be extended to ± 110 MHz.

<sup>f</sup> At frequencies below 3 GHz, the validity of tissue parameters ( $\epsilon$  and  $\sigma$ ) can be relaxed to ± 10% if liquid compensation formula is applied to measured SAR values. At frequencies above 3 GHz, the validity of tissue parameters ( $\epsilon$  and  $\sigma$ ) is restricted to ± 5%. The uncertainty is the RSS of the ConvF uncertainty for indicated target tissue parameters.

<sup>g</sup> Alpha/Depth are determined during calibration. SPEAG warrants that the remaining deviation due to the boundary effect after compensation is always less than ± 1% for frequencies below 3 GHz and below ± 2% for frequencies between 3-6 GHz at any distance larger than half the probe tip diameter from the boundary.

EX3DV4- SN:3866

May 27, 2015

### Frequency Response of E-Field (TEM-Cell:ifi110 EXX, Waveguide: R22)

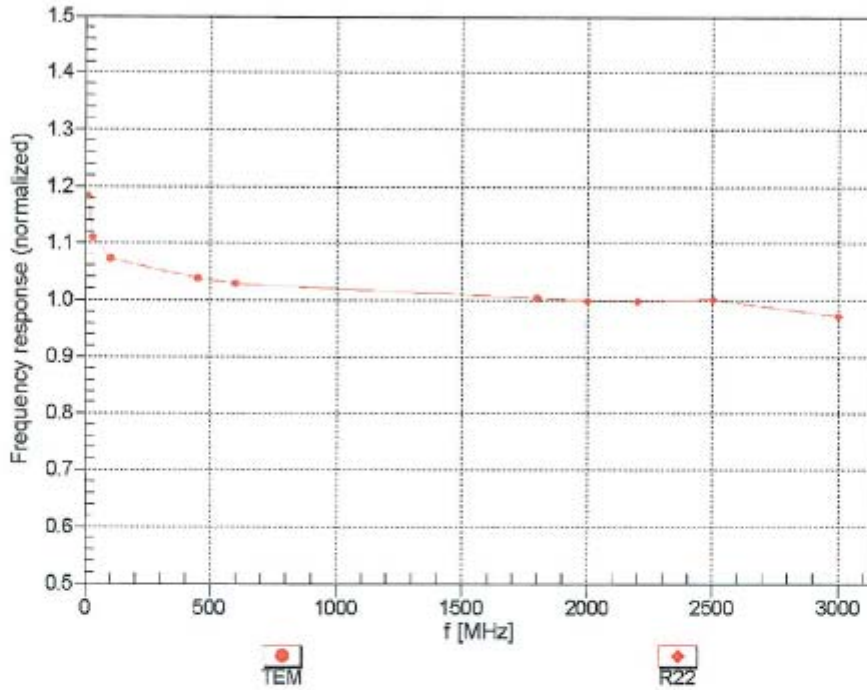

Uncertainty of Frequency Response of E-field:  $\pm 6.3\%$  (k=2)

EX3DV4- SN:3866

May 27, 2015

### Receiving Pattern ( $\phi$ ), $\vartheta = 0^\circ$

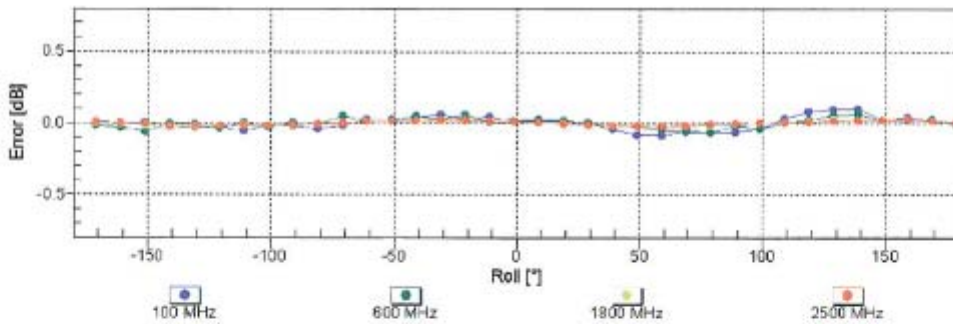
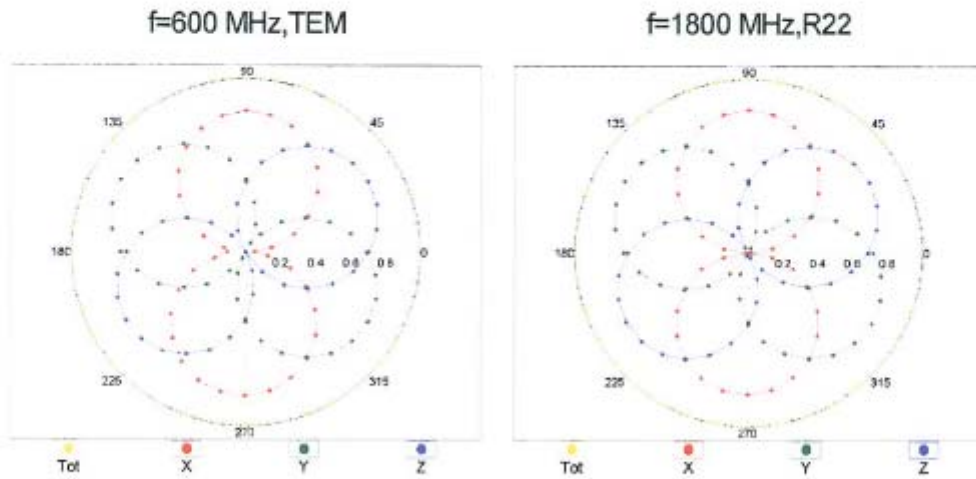

Uncertainty of Axial Isotropy Assessment:  $\pm 0.5\%$  ( $k=2$ )

EX3DV4- SN:3866

May 27, 2015

### Dynamic Range $f(\text{SAR}_{\text{head}})$ (TEM cell, $f_{\text{eval}} = 1900 \text{ MHz}$ )

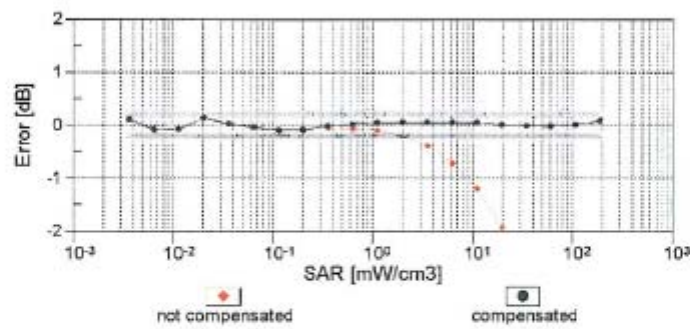
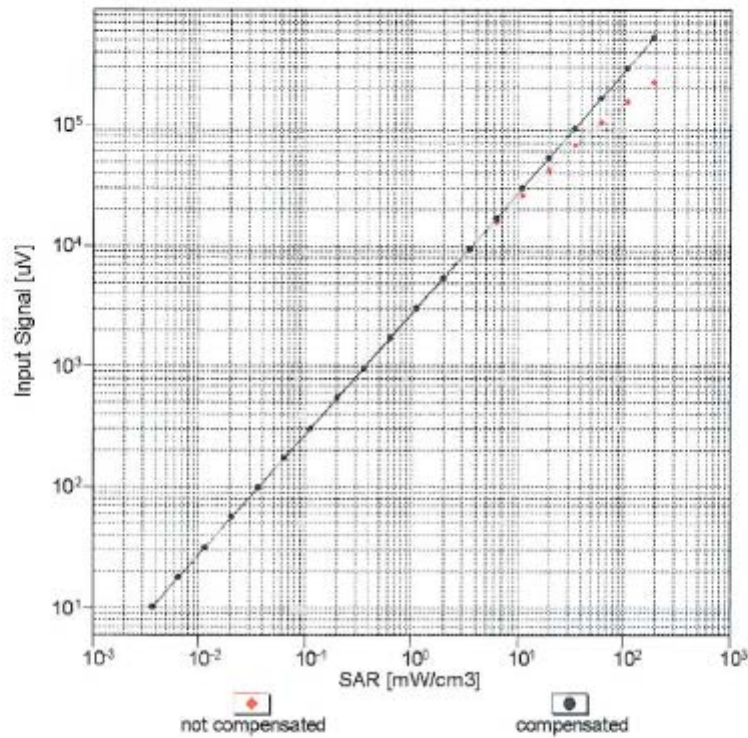

Uncertainty of Linearity Assessment:  $\pm 0.6\%$  (k=2)

EX3DV4- SN:3866

May 27, 2015

### Conversion Factor Assessment

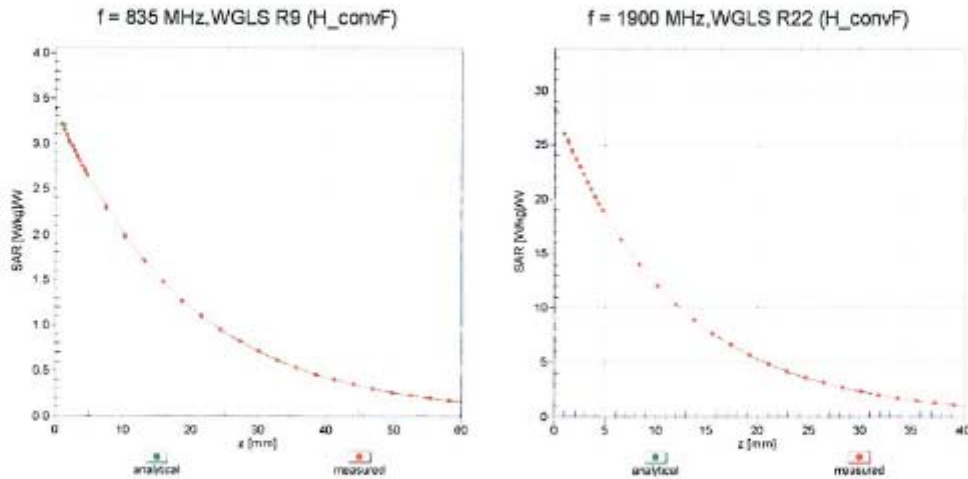

### Deviation from Isotropy in Liquid Error ( $\phi, \theta$ ), f = 900 MHz

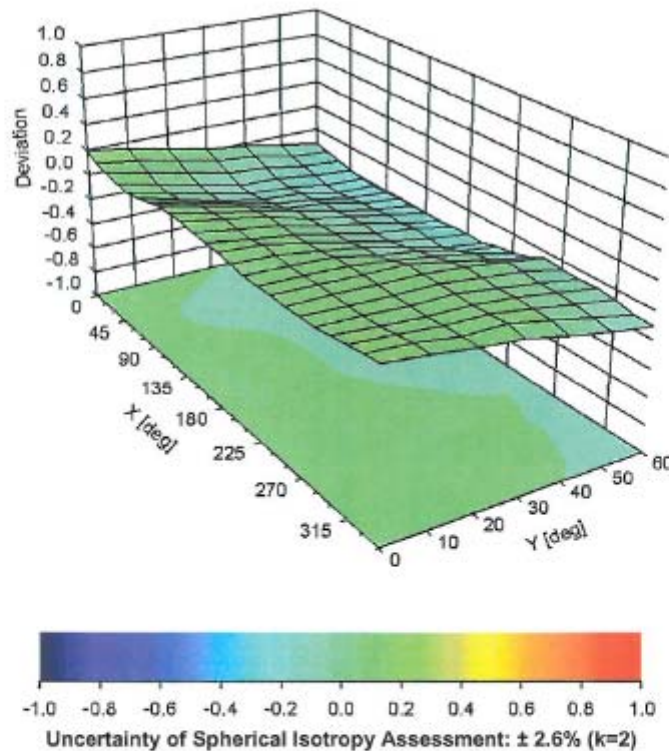

EX3DV4- SN:3866

May 27, 2015

## DASY/EASY - Parameters of Probe: EX3DV4 - SN:3866

### Other Probe Parameters

Sensor Arrangement	Triangular
Connector Angle (°)	68.9
Mechanical Surface Detection Mode	enabled
Optical Surface Detection Mode	disabled
Probe Overall Length	337 mm
Probe Body Diameter	10 mm
Tip Length	9 mm
Tip Diameter	2.5 mm
Probe Tip to Sensor X Calibration Point	1 mm
Probe Tip to Sensor Y Calibration Point	1 mm
Probe Tip to Sensor Z Calibration Point	1 mm
Recommended Measurement Distance from Surface	1.4 mm