

TEST REPORT

<p>DT&C Co., Ltd. 42, Yurim-ro, 154Beon-gil, Cheoin-gu, Yongin-si, Gyeonggi-do, Korea Tel : 031-321-2664, Fax : 031-321-1664</p>	<p>Report No : DRTFCC1510-0217 Pages:(1) / (53) page</p>	
<p>1. Customer</p> <ul style="list-style-type: none">• Name : BLUEBIRD INC.• Address : (Dogok-dong, SEI Tower 13,14) 39, Eonjuro30-gil, Gangnam-gu, Seoul, South Korea <p>2. Use of Report : FCC Original Grant</p> <p>3. Product Name (FCC ID): Enterprise Handheld Computer (SS4EF500)</p> <p>4. Date of Test : 2015-07-30 ~ 2015-09-30</p> <p>5. Test Method Used: FCC Part 22, 24, 27</p> <p>6. Testing Environment : See appended test report</p> <p>7. Test Result : <input checked="" type="checkbox"/> Pass <input type="checkbox"/> Fail</p> <p>The results shown in this test report refer only to the sample(s) tested unless otherwise stated. This Test Report cannot be reproduced, except in full.</p>		
Affirmation	Tested by Name : KwiCheol Yeom (Signature)	Technical Manager Name : GeunKi Son (Signature)
<p style="text-align: center;">2015. 10. 23.</p> <p style="text-align: center;">DT&C Co., Ltd.</p>		

Test Report Version

Test Report No.	Date	Description
DRTFCC1510-0217	Oct. 23, 2015	Initial issue

Table of Contents

- 1. GENERAL INFORMATION 5**
- 2. INTRODUCTION 6**
 - 2.1 EUT DESCRIPTION 6
 - 2.2 MEASURING INSTRUMENT CALIBRATION..... 6
 - 2.3 TEST FACILITY..... 6
- 3. DESCRIPTION OF TESTS..... 7**
 - 3.1 ERP&EIRP 7
 - 3.2 PEAK TO AVERAGE RATIO 9
 - 3.3 OCCUPIED BANDWIDTH..... 10
 - 3.4 BAND EDGE EMISSIONS (Conducted)..... 11
 - 3.5 SPURIOUS AND HARMONIC EMISSIONS (Conducted)..... 12
 - 3.6 UNDESIRABLE EMISSIONS (Radiated)..... 13
 - 3.7 FREQUENCY STABILITY 14
- 4. LIST OF TEST EQUIPMENT 15**
- 5. SUMMARY OF TEST RESULTS 16**
- 6. SAMPLE CALCULATION 17**
- 7. TEST DATA..... 18**
 - 7.1 OCCUPIED BANDWIDTH..... 18
 - 7.2 PEAKTOAVERAGERATIO..... 18
 - 7.3 BAND EDEG EMISSIONS (Conducted)..... 18
 - 7.4 SPURIOUS AND HARMONICS EMISSIONS (Conducted) 18
 - 7.5 EQUIVALENT ISOTROPIC RADIATED POWER 19
 - 7.5.1 LTE Band 17..... 19
 - 7.5.2 LTE Band 5..... 20
 - 7.5.3 LTE Band 4..... 21
 - 7.5.4 LTE Band 2..... 22
 - 7.6 UNDESIRABLE EMISSIONS (Radiated)..... 23
 - 7.6.1 LTE Band 17..... 23
 - 7.6.2 LTE Band 5..... 24
 - 7.6.3 LTE Band 4..... 25
 - 7.6.4 LTE Band 2..... 26
 - 7.7 FREQUENCY STABILITY 27
 - 7.7.1 LTE Band 17..... 27
 - 7.7.2 LTE Band 5..... 28
 - 7.7.3 LTE Band 4..... 29
 - 7.7.4 LTE Band 2..... 30
- 8. TEST PLOTS 31**
 - 8.1 OCCUPIED BANDWIDTH..... 31
 - 8.1.1 LTE Band 17..... 31
 - 8.1.2 LTE Band 5..... 32
 - 8.1.3 LTE Band 4..... 33

8.1.4 LTE Band 2.....	34
8.2 PEAK TO AVERAGE RATIO	35
8.2.1 LTE Band 4.....	35
8.2.2 LTE Band 2.....	36
8.3 BAND EDGE EMISSIONS(Conducted).....	37
8.3.1 LTE Band 17.....	37
8.3.2 LTE Band 5.....	39
8.3.3 LTE Band 4.....	41
8.3.4 LTE Band 2.....	43
8.4 SPURIOUS AND HARMONICS EMISSIONS(Conducted)	45
8.4.1 LTE Band 17.....	45
8.4.2 LTE Band 5.....	46
8.4.3 LTE Band 4.....	48
8.4.4 LTE Band 2.....	51

1. GENERAL INFORMATION

Applicant Name: BLUEBIRD INC.

Address: (Dogok-dong, SEI Tower 13,14) 39, Eonjuro30-gil, Gangnam-gu, Seoul, South Korea

FCC ID : SS4EF500

FCC Classification : Licensed Portable Transmitter Held to Ear (PCE)
EUT Type : Enterprise Handheld Computer

Model Name : EF500

Add Model Name : EF500R

Supplying power : DC 3.8 V

Antenna Information : Internal Antenna

Mode	TX Frequency (MHz)	Emission Designator	Modulation	ERP/EIRP	
				Max power(dBm)	Max power(W)
LTE Band 17	709 ~ 711	8M97G7D	QPSK	17.39	0.055
LTE Band 17	709 ~ 711	8M93W7D	16QAM	16.36	0.043
LTE Band 5	829 ~ 844	8M96G7D	QPSK	19.60	0.091
LTE Band 5	829 ~ 844	8M95W7D	16QAM	18.38	0.069
LTE Band 4	1715 ~ 1750	8M99G7D	QPSK	22.13	0.163
LTE Band 4	1715 ~ 1750	8M98W7D	16QAM	21.55	0.143
LTE Band 2	1855 ~ 1905	8M95G7D	QPSK	23.12	0.205
LTE Band 2	1855 ~ 1905	8M95W7D	16QAM	22.21	0.166

2. INTRODUCTION

2.1 EUT DESCRIPTION

The Equipment under Test (EUT) supports 850/1900 GSM/GPRS/EDGE, 850/1900 WCDMA/HSPA, Band 17 (10 MHz BW), Band 5 (10 MHz BW), Band 4 (10 MHz BW), Band 2 (10 MHz BW), LTE, 802.11 b/g/n WLAN, Bluetooth (BDR, EDR, LE) and NFC

2.2 MEASURING INSTRUMENT CALIBRATION

The measuring equipment, which was utilized in performing the tests documented herein, has been calibrated in accordance with the manufacturer's recommendations for utilizing calibration equipment, which is traceable to recognized national standards.

2.3 TEST FACILITY

The 3M test site and conducted measurement facility used to collect the radiated data are located at the 42, Yurim-ro, 154beon-gil, Cheoin-gu, Yongin-si, Gyeonggi-do, Korea 449-935. The site is constructed in conformance with the requirements.

- 3M test site registration Number: 165783

3. DESCRIPTION OF TESTS

3.1 ERP&EIRP

(Effective Radiated Power & Equivalent Isotropic Radiated Power)

Test Set-up

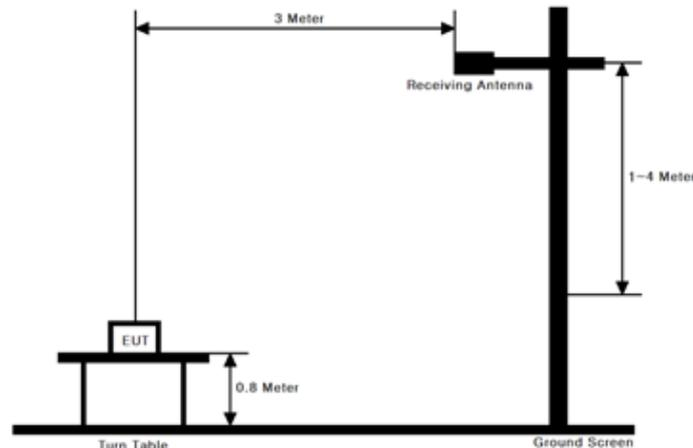

Test Procedure

- ANSI/TIA-603-C-2004 - Section 2.2.17
- KDB971168 v02r02 - Section 5.2.1

These measurements were performed at 3 & 10 m test site. The equipment under test is placed on a non-conductive table 0.8-meters above a turntable which is flush with the ground plane and 3 meters from the receive antenna.

Test setting

1. Set span to at least 1.5 times the OBW.
2. Set RBW = 1-5 % of the OBW, not to exceed 1 MHz.
3. Set VBW $\geq 3 \times$ RBW.
4. Set number of points in sweep $\geq 2 \times$ span / RBW.
5. Sweep time = auto couple.
6. Detector = RMS (power averaging).
7. If the EUT can be configured to transmit continuously (i.e., burst duty cycle ≥ 98 %), then set the trigger to free run.
8. If the EUT cannot be configured to transmit continuously (i.e., burst duty cycle < 98 %), then use a sweep trigger with the level set to enable triggering only on full power bursts and configure the EUT to transmit at full power for the entire duration of each sweep.
Ensure that the sweep time is less than or equal to the transmission burst duration.
9. Trace average at least 100 traces in power averaging (i.e., RMS) mode.
10. Compute the power by integrating the spectrum across the OBW of the signal using the instrument's band power measurement function, with the band limits set equal to the OBW band edges. If the instrument does not have a band power function, then sum the spectrum levels (in linear power units) at intervals equal to the RBW extending across the entire OBW of the spectrum.

The receive antenna height and turntable rotations were adjusted for the highest reading on the receive spectrum analyzer.

A half-wave dipole was substituted in place of the EUT. This dipole antenna was driven by a signal generator and the level of the signal generator was adjusted to obtain the same receive spectrum analyzer reading. The conducted power at the terminal of the substitute antenna is measured.

The ERP/EIRP is calculated using the following formula:

ERP/EIRP = The conducted power at the substitute antenna's terminal [dBm] + Substitute Antenna gain [dBd for ERP , dBi for EIRP]

For readings above 1 GHz, the above procedure is repeated using horn antennas and the difference between the gain of the horn antenna and an isotropic antenna are taken into consideration.

3.2 PEAK TO AVERAGE RATIO

Test set-up

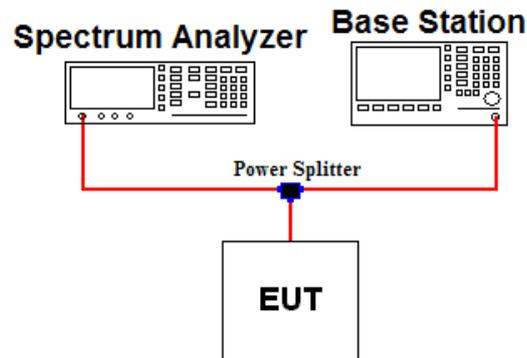

Test Procedure

- KDB971168 v02r02 - Section 5.7.1

A peak to average ratio measurement is performed at the conducted port of the EUT. The spectrum analyzers Complementary Cumulative Distribution Function (CCDF) measurement profile is used to determine the largest deviation between the average and the peak power of the EUT in a given bandwidth. The CCDF curve shows how much time the peak waveform spends at or above a given average power level. The present of time the signal spends at or above the level defines the probability for that particular power level.

Test setting

The spectrum Analyzer`s CCDF measurement function is enabled.

1. Set resolution/measurement bandwidth \geq signal`s occupied bandwidth.
2. Set the number of counts to a value that stabilizes the measured CCDF curve
3. Set the measurement interval as follows:
 - 1) For continuous transmissions, set to 1 ms.
 - 2) For burst transmissions, employ an external trigger that is synchronized with the EUT burst timing sequence, or use the internal burst trigger with a trigger level that allows the burst to stabilize and set the measurement interval to a time that is less than or equal to the burst duration.
4. Record the maximum PAPR level associated with a probability of 0.1 %

3.3 OCCUPIED BANDWIDTH.

Test set-up

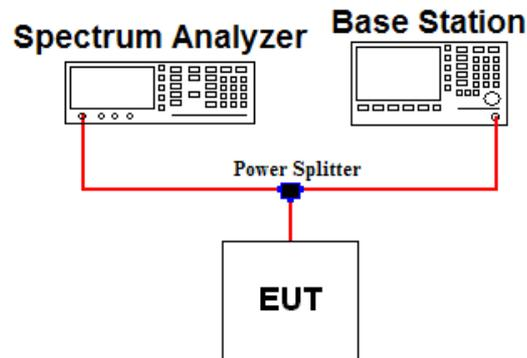

Test Procedure

- KDB971168 v02r02 - Section 4.2

The occupied bandwidth, that is the frequency bandwidth such that, below its lower and above its upper frequency limits, the mean powers radiated are each equal to 0.5 percent of the total mean power of a given emission.

Test setting

1. The signal analyzer's automatic bandwidth measurement capability was used to perform the 99 % occupied bandwidth and the 26 dB bandwidth. The bandwidth measurement was not influenced by any intermediate power nulls in the fundamental emission.
2. $RBW = 1 \sim 5 \%$ of the expected OBW & $VBW \geq 3 \times RBW$
3. Detector = Peak
4. Trance mode = Max hold
5. Sweep = Auto couple
6. The trace was allowed to stabilize
7. If necessary, step 2 ~ 6 were repeated after changing the RBW such that it would be within 1 ~ 5 % of the 99 % occupied bandwidth observed in step 6.

3.4 BAND EDGE EMISSIONS (Conducted)

Test set-up

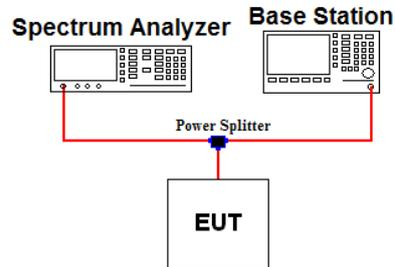

Test Procedure

- KDB971168 v02r02 - Section 6.0

All out of band emissions are measured by means of a calibrated spectrum analyzer. The EUT was setup to maximum output power at its lowest and highest channel with all bandwidths, modulations and RB configurations.

The power of any spurious emission shall be attenuated below the transmitter power (P) by at least $43 + 10 \log(P)$ dB or requirements on note 2 in case of band 7 and 41.

Test setting

1. Start and stop frequency were set such that the band edge would be placed in the center of the plot
2. Span was set large enough so as to capture all out of band emissions near the band edge
3. RBW $\geq 1\%$ of the emission bandwidth or 2% of the emission bandwidth (refer to note 2)
4. VBW $\geq 3 \times$ RBW
5. Detector = RMS & Trace mode = Max hold
6. Sweep time = Auto couple or 1 s for band edge
7. Number of sweep point $\geq 2 \times$ span / RBW
8. The trace was allowed to stabilize

Note 1: In the 1 MHz bands immediately outside and adjacent to the frequency block a resolution bandwidth of **at least one percent** of the emission bandwidth of the fundamental emission of the transmitter may be employed to demonstrate compliance with the out-of-band emissions limit. The emission bandwidth is defined as the width of the signal between two points, one below the carrier center frequency and one above the carrier center frequency, outside of which all emission are attenuated at least 26 dB below the transmitter power.

Note 2: For part 27.53(m)(4) the attenuation factor shall be not less than $40 + 10 \log(P)$ dB on all frequencies between the channel edge and 5 MHz from the channel edge, $43 + 10 \log(P)$ dB on all frequencies between 5 MHz and X MHz from the channel edge, and $55 + 10 \log(P)$ dB on all frequencies more than X MHz from the channel edge, where X is the greater of 6 MHz or the actual emission bandwidth as defined in paragraph (m)(6) of this section. In addition, the attenuation factor shall not be less that $43 + 10 \log(P)$ dB on all frequencies between 2490.5 MHz and 2496 MHz and $55 + 10 \log(P)$ dB at or below 2490.5 MHz. For mobile digital stations, in the 1 MHz bands immediately outside and adjacent to the frequency block a resolution bandwidth of **at least two percent** may be employed, except when the 1 MHz band is 2495-2496 MHz, in which case a resolution bandwidth of **at least one percent** may be employed.

3.5 SPURIOUS AND HARMONIC EMISSIONS (Conducted)

Test set-up

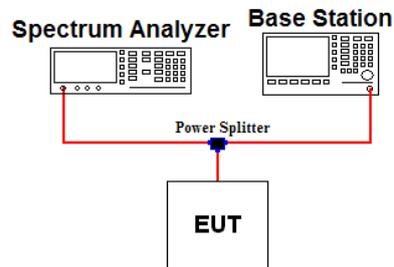

Test Procedure

- KDB971168 v02r02 - Section 6.0

The level of the carrier and the various conducted spurious and harmonic frequencies is measured by means of a calibrated spectrum analyzer. The EUT was setup to maximum output power at its low, middle, high channel with all bandwidths, modulations and RB configurations. The spectrum is scanned from 30 MHz up to a frequency including its 10th harmonic.

The power of any spurious emission shall be attenuated below the transmitter power (P) by at least $43 + 10 \log(P)$ dB or $55 + 10 \log(P)$ in case of band 7 and 41.

Test setting

1. RBW = 100 KHz or 1 MHz & VBW $\geq 3 \times$ RBW (Refer to Note 1)
2. Detector = RMS & Trace mode = Max hold
3. Sweep time = Auto couple
4. Number of sweep point $\geq 2 \times$ span / RBW
5. The trace was allowed to stabilize

Note 1: Compliance with these provisions is based on the use of measurement instrumentation employing a resolution bandwidth of 100 kHz or greater for Part 22 and 1 MHz or greater for Part 24, 27.

3.6 UNDESIRABLE EMISSIONS (Radiated)

Test Set-up

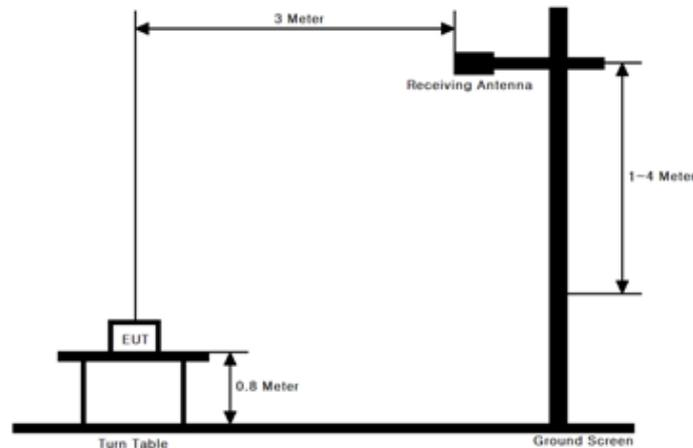

Test Procedure

- ANSI/TIA-603-C-2004 - Section 2.2.12
- KDB971168 v02r02 - Section 5.8

These measurements were performed at 3 & 10m test site. The equipment under test is placed on a non-conductive table 0.8-meters above a turntable which is flush with the ground plane and 3 meters from the receive antenna.

Test setting

1. RBW = 100 kHz for below 1 GHz and 1 MHz for above 1 GHz / VBW \geq 3 X RBW
2. Detector = Peak & Trace mode = Max hold
3. Sweep time = Auto couple
4. Number of sweep point \geq 2 X span / RBW
5. The trace was allowed to stabilize

The receive antenna height and turntable rotations were adjusted for the highest reading on the receive spectrum analyzer.

For radiated power measurements below 1 GHz, a half-wave dipole was substituted in place of the EUT. This dipole antenna was driven by a signal generator and the level of the signal generator was adjusted to obtain the same spectrum analyzer reading.

For radiated power measurements above 1 GHz, a Horn antenna was substituted in place of the EUT. This Horn antenna was driven by a signal generator and the level of the signal generator was adjusted to obtain the same spectrum analyzer reading. The difference between the gain of the horn and an isotropic antenna are taken into consideration.

This measurement was performed with the EUT oriented in 3 orthogonal axis.

3.7 FREQUENCY STABILITY

Test Set-up

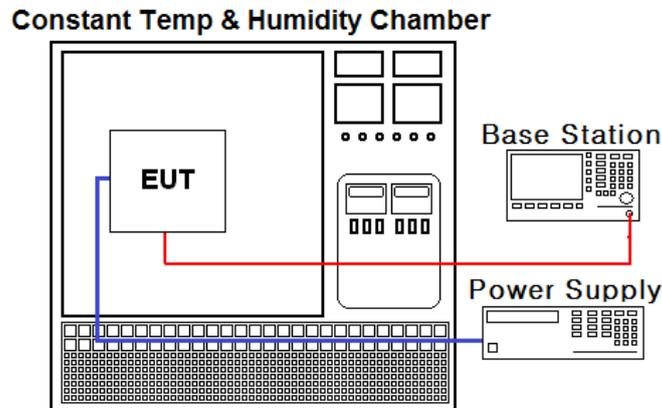

Test Procedure

- ANSI/TIA-603-C-2004
- KDB971168 v02r02 - Section 9.0

The frequency stability of the transmitter is measured by:

a.) **Temperature:**

The temperature is varied from - 30 °C to + 50 °C using an environmental chamber.

b.) **Primary Supply Voltage:**

The primary supply voltage is varied from 85 % to 115 % of the nominal value for non hand-carried battery and AC powered equipment. For hand-carried, battery-powered equipment, primary supply voltage is reduced to the battery operating end point which shall be specified by the manufacturer.

Specification:

The frequency stability shall be sufficient to ensure that the fundamental emission stays within the authorized frequency block for Part 24. The frequency stability of the transmitter shall be maintained within $\pm 0.00025\%$ (± 2.5 ppm) of the center frequency for Part 22.

Time Period and Procedure:

1. The carrier frequency of the transmitter is measured at room temperature.
(25 °C to provide a reference)
2. The equipment is turned on in a “standby” condition for one minute before applying power to the transmitter. Measurement of the carrier frequency of the transmitter is made within one minute after applying power to the transmitter.
3. Frequency measurements are made at 10 °C intervals ranging from -30 °C to +50 °C.
A period of at least one half-hour is provided to allow stabilization of the equipment at each temperature level.

4. LIST OF TEST EQUIPMENT

Type	Manufacturer	Model	Cal.Date (yy/mm/dd)	Next.Cal. Date (yy/mm/dd)	S/N
MXA Signal Analyzer	Agilent Technologies	N9020A	15/02/26	16/02/26	MY50200816
Dynamic Measurement DC Source	Agilent Technologies	66332A	15/01/06	16/01/06	GB37470190
Temp & Humi Test Chamber	SJ Science	SJ-TH-S50	15/02/26	16/02/26	SJ-TH-S50-140205
RadioCommunication Analyzer	Anritsu	MT8820C	15/01/09	16/01/09	6201274516
Power Splitter	Anritsu	K241B	15/06/25	16/06/25	017060
Thermohygrometer	BODYCOM	BJ5478	15/05/08	16/05/08	120612-2
Digital Multimeter	Agilent Technologies	34401A	15/01/06	16/01/06	US36099541
Vector Signal Generator	Rohde Schwarz	SMBV100A	15/01/06	16/01/06	255571
Signal Generator	Rohde Schwarz	SMF100A	15/06/29	16/06/29	102341
Loop Antenna	Schwarzbeck	FMZB1513	14/04/29	16/04/29	1513-128
TRILOG Broadband Test-Antenna	SCHWARZBECK	VULB 9160	14/04/04	16/04/04	3357
Dipole Antenna	Schwarzbeck	VHA9103	13/10/24	15/10/24	2116
Dipole Antenna	Schwarzbeck	VHA9103	14/04/01	16/04/01	2117
Dipole Antenna	Schwarzbeck	UHA9105	13/10/24	15/10/24	2261
Dipole Antenna	Schwarzbeck	UHA9105	14/04/01	16/04/01	2262
HORN ANT	ETS	3115	15/02/09	17/02/09	00021097
HORN ANT	ETS	3117	14/05/12	16/05/12	140394
HORN ANT	A.H.Systems	SAS-574	15/04/30	17/04/30	154
HORN ANT	ETS	3160-09-01	15/09/03	17/09/03	00158433
Low Noise Pre Amplifier	TSJ	MLA-010K01-B01-27	15/04/09	16/04/09	1844538
Amplifier	RF Bay Inc	MPA-40-40	15/05/08	16/05/08	21151801
Amplifier	EMPOWER	BBS3Q7ELU	15/09/09	16/09/09	1020
Amplifier (30dB)	Agilent	8449B	14/11/06	15/11/06	3008A02108
High-pass filter	Wainwright	WHKX12-935-1000-15000-40SS	15/09/23	16/09/23	7
High-pass filter	Wainwright	WHKX12-2580-3000-18000-80SS	15/09/23	16/09/23	3
High-pass filter	Wainwright	WHNX5.0	15/09/09	16/09/09	8

5. SUMMARY OF TEST RESULTS

FCC Part Section(s)	Test Description	Test Limit	Test Condition	Status Note 1
2.1046	Conducted Output Power	N/A	Conducted	C Note2
2.1049	Occupied Bandwidth	N/A		C
24.232(d) 27.50(d.5)	Peak to Average Ratio	< 13 dB		C
2.1051 22.917(a) 24.238(a) 27.53(g) 27.53(h)	Band Edge / conducted Spurious Emissions	> 43 + 10log ₁₀ (P) dB at Band edge and for all out-of-band emissions		C
27.53(m)	Band Edge / conducted Spurious Emissions	> 40 + 10log ₁₀ (P) dB at channel edge and 5 MHz from the channel edge > 43 + 10log ₁₀ (P) dB at 5 MHz and X MHz from the channel edge > 55 + 10log ₁₀ (P) dB at all frequencies more than X MHz from the channel edge		C Note3
2.1055 22.355 24.235 27.54	Frequency Stability	< 2.5 ppm (Part 22) Fundamental emissions must stay within Authorized frequency block (Part 24, 27)		C
22.913(a.2)	Effective Radiated Power (Band5)	< 7 Watts max. ERP	Radiated	C
27.50(c.10)	Effective Radiated Power (Band17)	< 3 Watts max. ERP		C
24.232(c) 27.50(h.2)	Equivalent Isotropic Radiated Power (Band 2,7)	< 2 Watts max. EIRP		C
27.50(d.4)	Equivalent Isotropic Radiated Power (Band 4)	< 1 Watts max. ERP		C
2.1053 22.917(a) 24.238(a) 27.53(g) 27.53(h)	Undesirable Emissions	> 43 + 10log ₁₀ (P) dB at Band edge and for all out-of-band emissions		C
27.53(m)	Undesirable Emissions	> 40 + 10log ₁₀ (P) dB at channel edge and 5 MHz from the channel edge > 43 + 10log ₁₀ (P) dB at 5 MHz and X MHz from the channel edge > 55 + 10log ₁₀ (P) dB at all frequencies more than X MHz from the channel edge		C
<p>Note 1: C=Comply NC=Not Comply NT=Not Tested NA=Not Applicable</p> <p>Note 2: Refer to RF Exposure Report (Test Report_SAR)</p> <p>Note 3: where X is the greater of 6 MHz or the actual emission bandwidth as defined in paragraph (m)(6) of this section.</p>				

The sample was tested according to the following specification:
ANSI/TIA/EIA-603-C-2004 and KDB 971168 D01 v02r02

6. SAMPLE CALCULATION

A. Emission Designator

LTE Band 17(QPSK)

Emission Designator = **8M97G7D**
 LTE OBW = 8.965 MHz
 G = Phase Modulation
 7 = Quantized/Digital Info
 D = Data Transmission

LTE Band 5(QPSK)

Emission Designator = **8M96G7D**
 LTE OBW = 8.963 MHz
 G = Phase Modulation
 7 = Quantized/Digital Info
 D = Data Transmission

LTE Band 4(QPSK)

Emission Designator = **8M99G7D**
 LTE OBW = 8.989 MHz
 G = Phase Modulation
 7 = Quantized/Digital Info
 D = Data Transmission

LTE Band 2(QPSK)

Emission Designator = **8M95G7D**
 LTE OBW = 8.946 MHz
 G = Phase Modulation
 7 = Quantized/Digital Info
 D = Data Transmission

LTE Band 17(16QAM)

Emission Designator = **8M93W7D**
 LTE OBW = 8.932 MHz
 W = Amplitude/Angle Modulated
 7 = Quantized/Digital Info
 D = Data Transmission

LTE Band 5(16QAM)

Emission Designator = **8M95W7D**
 LTE OBW = 8.948 MHz
 W = Amplitude/Angle Modulated
 7 = Quantized/Digital Info
 D = Data Transmission

LTE Band 4(16QAM)

Emission Designator = **8M98W7D**
 LTE OBW = 8.979 MHz
 W = Amplitude/Angle Modulated
 7 = Quantized/Digital Info
 D = Data Transmission

LTE Band 2(16QAM)

Emission Designator = **8M95W7D**
 LTE OBW = 8.948 MHz
 W = Amplitude/Angle Modulated
 7 = Quantized/Digital Info
 D = Data Transmission

B. EIRP Sample Calculation

Channel Bandwidth (MHz)	Test Frequency (MHz)	Test Mode	RB Size/Offset	Spectrum Reading Value(dBm)	EUT Axis	Ant Pol (H/V)	Level(dBm) @ Ant Terminal	TX Ant Gain (dBi)	EIRP (dBm)	EIRP (W)
10	709	QPSK	1/0	-18.07	X	H	15.71	1.32	17.03	0.050

EIRP = @ Ant Terminal LEVEL(dBm) + Ant. Gain

- 1) The EUT mounted on a non-conductive turntable is 0.8 meter above test site ground level.
- 2) During the test, the turn table is rotated until the maximum signal is found.
- 3) Record the field strength meter's level.
- 4) Replace the EUT with dipole/Horn antenna that is connected to a calibrated signal generator.
- 5) Increase the signal generator output till the field strength meter's level is equal to the item (3).
- 6) The signal generator output level with Ant. Gain is the rating of effective isotropic radiated power (EIRP).

7. TEST DATA

7.1 OCCUPIED BANDWIDTH

- Plots of the EUT's Occupied Bandwidth are shown in Clause 8.1

7.2 PEAK TO AVERAGE RATIO

- Plots of the EUT's Peak- to- Average Ratio are shown in Clause 8.2

7.3 BAND EDGE EMISSIONS (Conducted)

- Plots of the EUT's Band Edge Emissions are shown in Clause 8.3

7.4 SPURIOUS AND HARMONICS EMISSIONS (Conducted)

- Plots of the EUT's Spurious Emissions are shown in Clause 8.4

7.5 EQUIVALENT ISOTROPIC RADIATED POWER

7.5.1 LTE Band 17

Channel Bandwidth (MHz)	Test Frequency (MHz)	Test Mode	RB Size/ Offset	EUT Axis	Ant Pol (H/V)	Level(dBm) @ Ant Terminal	TX Ant Gain (dBd)	ERP (dBm)	ERP (W)
10	709	QPSK	1/0	X	H	15.71	1.32	17.03	0.050
		16QAM	1/0	X	H	14.43	1.32	15.75	0.038
	711	QPSK	1/49	X	H	16.07	1.32	17.39	0.055
		16QAM	1/49	X	H	15.04	1.32	16.36	0.043

Note: This device was tested under all bandwidths, modulations and RB configurations and the worst case data are reported in the table above.

7.5.2 LTE Band 5

Channel Bandwidth (MHz)	Test Frequency (MHz)	Test Mode	RB Size/Offset	EUT Axis	Ant Pol (H/V)	Level(dBm) @ Ant Terminal	TX Ant Gain (dBd)	ERP (dBm)	ERP (W)
10	829	QPSK	1/0	X	H	18.39	1.21	19.60	0.091
		16QAM	1/0	X	H	17.17	1.21	18.38	0.069
	836.5	QPSK	1/0	X	H	16.90	1.17	18.07	0.064
		16QAM	1/0	X	H	16.01	1.17	17.18	0.052
	844	QPSK	1/25	X	H	16.69	1.13	17.82	0.061
		16QAM	1/25	X	H	15.66	1.13	16.79	0.048

Note: This device was tested under all bandwidths, modulations and RB configurations and the worst case data are reported in the table above.

7.5.3 LTE Band 4

Channel Bandwidth (MHz)	Test Frequency (MHz)	Test Mode	RB Size/ Offset	EUT Axis	Ant Pol (H/V)	Level(dBm) @ Ant Terminal	TX Ant Gain (dBi)	EIRP (dBm)	EIRP (W)
10	1715	QPSK	1/49	X	H	12.82	8.87	21.69	0.148
		16QAM	1/49	X	H	12.68	8.87	21.55	0.143
	1732.5	QPSK	1/0	X	H	12.17	8.88	21.05	0.127
		16QAM	1/0	X	H	11.69	8.88	20.57	0.114
	1750	QPSK	1/25	X	H	13.23	8.90	22.13	0.163
		16QAM	1/25	X	H	12.63	8.90	21.53	0.142

Note: This device was tested under all bandwidths, modulations and RB configurations and the worst case data are reported in the table above.

7.5.4 LTE Band 2

Channel Bandwidth (MHz)	Test Frequency (MHz)	Test Mode	RB Size/Offset	EUT Axis	Ant Pol (H/V)	Level(dBm) @ Ant Terminal	TX Ant Gain (dBi)	EIRP (dBm)	EIRP (W)
10	1855	QPSK	1/0	X	H	12.28	9.02	21.30	0.135
		16QAM	1/0	X	H	11.26	9.02	20.28	0.107
	1880	QPSK	1/49	X	H	11.20	9.05	20.25	0.106
		16QAM	1/49	X	H	10.32	9.05	19.37	0.086
	1905	QPSK	1/0	X	H	14.04	9.08	23.12	0.205
		16QAM	1/0	X	H	13.13	9.08	22.21	0.166

Note: This device was tested under all bandwidths, modulations and RB configurations and the worst case data are reported in the table above.

7.6 UNDESIRABLE EMISSIONS (Radiated)

7.6.1 LTE Band 17

B.W (MHz)	Test Freq. (MHz)	RB Size/Offset	Test Mode	Freq.(MHz)	EUT Axis	Ant Pol (H/V)	Level(dBm) @ Ant Terminal	TX Ant Gain(dBd)	Result		Limit (dBc)
									(dBm)	(dBc)	
10	709	1/0	QPSK	1409.03	Z	H	-53.92	5.94	-47.98	65.01	30.03
				-	-	-	-	-	-	-	
	1/0	16QAM	1409.22	Z	H	-53.95	5.94	-48.01	63.76	28.75	
			-	-	-	-	-	-	-		
	711	1/49	QPSK	1413.02	Z	H	-54.91	5.96	-48.95	66.34	30.39
				-	-	-	-	-	-	-	
1/49	16QAM	1413.07	Z	H	-55.52	5.96	-49.56	65.92	29.36		
		-	-	-	-	-	-	-			

Note 1: Limit Calculation = $43 + 10\log_{10}(P[\text{Watts}])$

Note 2: This device was tested under all bandwidths, modulations and RB configurations and the worst case data are reported in the table above.

Note 3: The frequency spectrum is examined from 9 kHz to the 10th harmonic of the fundamental frequency of the transmitter. No other spurious and harmonic emissions were reported greater than listed emissions above table.

7.6.2 LTE Band 5

B.W (MHz)	Test Freq. (MHz)	RB Size/Offset	Test Mode	Freq.(MHz)	EUT Axis	Ant Pol (H/V)	Level(dBm) @ Ant Terminal	TX Ant Gain(dBd)	Result		Limit (dBc)
									(dBm)	(dBc)	
10	829	1/0	QPSK	1649.28	Z	H	-54.45	6.64	-47.81	67.41	32.60
				2473.92	Y	H	-56.26	7.58	-48.68	68.28	
		1/0	16QAM	1649.21	Z	H	-54.47	6.64	-47.83	66.21	31.38
				2474.01	Y	H	-55.81	7.58	-48.23	66.61	
	836.5	1/0	QPSK	1664.17	Z	H	-53.47	6.65	-46.82	64.89	31.07
				2496.16	Y	H	-56.45	7.61	-48.84	66.91	
		1/0	16QAM	1664.19	Z	H	-54.20	6.65	-47.55	64.73	30.18
				2496.15	Y	H	-56.65	7.61	-49.04	66.22	
	844	1/25	QPSK	1649.19	Z	H	-54.11	6.64	-47.47	65.29	30.82
				2518.54	Y	H	-57.31	7.61	-49.70	67.52	
		1/0	16QAM	1649.24	Z	H	-54.92	6.64	-48.28	65.07	29.79
				2518.51	Y	H	-57.49	7.61	-49.88	66.67	

Note 1: Limit Calculation = $43 + 10\log_{10}(P[\text{Watts}])$

Note 2: This device was tested under all bandwidths, modulations and RB configurations and the worst case data are reported in the table above.

Note 3: The frequency spectrum is examined from 9 kHz to the 10th harmonic of the fundamental frequency of the transmitter. No other spurious and harmonic emissions were reported greater than listed emissions above table.

7.6.3 LTE Band 4

B.W (MHz)	Test Freq. (MHz)	RB Size/Offset	Test Mode	Freq.(MHz)	EUT Axis	Ant Pol (H/V)	Level(dBm) @ Ant Terminal	TX Ant Gain(dBi)	Result		Limit (dBc)
									(dBm)	(dBc)	
10	1715	1/49	QPSK	3421.08	Z	H	-51.39	7.89	-43.50	65.19	34.69
				5131.76	Y	H	-43.81	8.59	-35.22	56.91	
		1/49	16QAM	3421.09	Z	H	-51.45	7.89	-43.56	65.11	34.55
				5131.87	Y	H	-44.39	8.59	-35.80	57.35	
	1732.5	1/0	QPSK	3456.05	Z	H	-52.27	7.92	-44.35	65.40	34.05
				5184.29	Y	H	-43.42	8.61	-34.81	55.86	
		1/0	16QAM	3455.96	Z	H	-52.53	7.92	-44.61	65.18	33.57
				5184.28	Y	H	-43.92	8.61	-35.31	55.88	
	1750	1/25	QPSK	3491.07	Z	H	-51.14	7.95	-43.19	65.32	35.13
				5236.80	Y	H	-42.71	8.63	-34.08	56.21	
		1/25	16QAM	3491.18	Z	H	-50.84	7.95	-42.89	64.42	34.53
				5236.74	Y	H	-42.68	8.63	-34.05	55.58	

Note 1: Limit Calculation = 43 + 10log₁₀ (P[Watts])

Note 2: This device was tested under all bandwidths, modulations and RB configurations and the worst case data are reported in the table above.

Note 3: The frequency spectrum is examined from 9 kHz to the 10th harmonic of the fundamental frequency of the transmitter. No other spurious and harmonic emissions were reported greater than listed emissions above table.

7.6.4 LTE Band 2

B.W (MHz)	Test Freq. (MHz)	RB Size/Offset	Test Mode	Freq.(MHz)	EUT Axis	Ant Pol (H/V)	Level(dBm) @ Ant Terminal	TX Ant Gain(dBi)	Result		Limit (dBc)	
									(dBm)	(dBc)		
10	1855	1/0	QPSK	3701.20	Z	H	-48.46	9.91	-38.55	59.85	34.30	
				5551.18	Y	H	-40.32	10.98	-29.34	50.64		
				-	-	-	-	-	-	-		
		1/0	16QAM	3701.05	Z	H	-48.89	9.91	-38.98	59.26		33.28
				5551.75	Y	H	-41.02	10.98	-30.04	50.32		
				-	-	-	-	-	-	-		
	1880	1/49	QPSK	3751.10	Z	H	-52.26	9.86	-42.40	62.65	33.25	
				5626.84	Y	H	-41.10	11.09	-30.01	50.26		
				-	-	-	-	-	-	-		
		1/49	16QAM	3751.12	Z	H	-52.85	9.86	-42.99	62.36	32.37	
				5626.77	Y	H	-41.46	11.09	-30.37	49.74		
				-	-	-	-	-	-	-		
	1905	1/0	QPSK	3801.24	Z	H	-51.35	9.81	-41.54	64.66	36.12	
				5701.72	Y	H	-43.51	11.20	-32.31	55.43		
				-	-	-	-	-	-	-		
1/0		16QAM	3801.11	Z	H	-51.61	9.81	-41.80	64.01	35.21		
			5701.78	Y	H	-44.02	11.20	-32.82	55.03			
			-	-	-	-	-	-	-			

Note 1: Limit Calculation = 43 + 10log₁₀ (P[Watts])

Note 2: This device was tested under all bandwidths, modulations and RB configurations and the worst case data are reported in the table above.

Note 3: The frequency spectrum is examined from 9 kHz to the 10th harmonic of the fundamental frequency of the transmitter. No other spurious and harmonic emissions were reported greater than listed emissions above table.

7.7 FREQUENCY STABILITY

7.7.1 LTE Band 17

OPERATING FREQUENCY : 710 MHz
 CHANNEL : 23790
 REFERENCE VOLTAGE : 3.80 VDC
 LIMIT : The frequency stability shall be sufficient to ensure that the fundamental emission stays within the authorized frequency block.

VOLTAGE (%)	POWER (V DC)	TEMP (°C)	FREQUENCY (Hz)	FREQ.Dev (Hz)	Deviation	
					(ppm)	(%)
100%	3.80	+25(Ref)	710,000,003	3	0.0042	0.000000423
100%		-30	710,000,005	5	0.0070	0.000000704
100%		-20	710,000,004	4	0.0056	0.000000563
100%		-10	709,999,998	-2	-0.0028	-0.000000282
100%		0	709,999,997	-3	-0.0042	-0.000000423
100%		10	710,000,003	3	0.0042	0.000000423
100%		20	710,000,004	4	0.0056	0.000000563
100%		30	710,000,004	4	0.0056	0.000000563
100%		40	710,000,008	8	0.0113	0.000001127
100%		50	710,000,002	2	0.0028	0.000000282
115%		4.37	25	709,999,996	-4	-0.0056
BATT.ENDPOINT	3.23	25	709,999,998	-2	-0.0028	-0.000000282

7.7.2 LTE Band 5

OPERATING FREQUENCY : 836.5 MHz
 CHANNEL : 20525
 REFERENCE VOLTAGE : 3.80 VDC
 LIMIT : ± 0.00025 % or 2.5 ppm

VOLTAGE (%)	POWER (V DC)	TEMP (°C)	FREQUENCY (Hz)	FREQ.Dev (Hz)	Deviation	
					(ppm)	(%)
100%	3.80	+25(Ref)	836,500,006	6	0.0072	0.000000717
100%		-30	836,500,003	3	0.0036	0.000000359
100%		-20	836,500,004	4	0.0048	0.000000478
100%		-10	836,499,998	-2	-0.0024	-0.000000239
100%		0	836,500,008	8	0.0096	0.000000956
100%		10	836,499,996	-4	-0.0048	-0.000000478
100%		20	836,499,995	-5	-0.0060	-0.000000598
100%		30	836,500,007	7	0.0084	0.000000837
100%		40	836,500,003	3	0.0036	0.000000359
100%		50	836,500,002	2	0.0024	0.000000239
115%	4.37	25	836,499,996	-4	-0.0048	-0.000000478
BATT.ENDPOINT	3.23	25	836,500,002	2	0.0024	0.000000239

7.7.3 LTE Band 4

OPERATING FREQUENCY : 1732.5 MHz
 CHANNEL : 20175
 REFERENCE VOLTAGE : 3.80_VDC
 LIMIT : The frequency stability shall be sufficient to ensure that the fundamental emission stays within the authorized frequency block.

VOLTAGE (%)	POWER (V DC)	TEMP (°C)	FREQUENCY (Hz)	FREQ.Dev (Hz)	Deviation	
					(ppm)	(%)
100%	3.80	+25(Ref)	1,732,500,003	3	0.0017	0.000000173
100%		-30	1,732,500,005	5	0.0029	0.000000289
100%		-20	1,732,500,004	4	0.0023	0.000000231
100%		-10	1,732,500,007	7	0.0040	0.000000404
100%		0	1,732,499,994	-6	-0.0035	-0.000000346
100%		10	1,732,499,998	-2	-0.0012	-0.000000115
100%		20	1,732,499,995	-5	-0.0029	-0.000000289
100%		30	1,732,500,004	4	0.0023	0.000000231
100%		40	1,732,500,002	2	0.0012	0.000000115
100%		50	1,732,499,997	-3	-0.0017	-0.000000173
115%	4.37	25	1,732,500,002	2	0.0012	0.000000115
BATT.ENDPOINT	3.23	25	1,732,499,999	-1	-0.0006	-0.000000058

7.7.4 LTE Band 2

OPERATING FREQUENCY : 1880 MHz
 CHANNEL : 18900
 REFERENCE VOLTAGE : 3.80 VDC
 DEVIATION LIMIT : The frequency stability shall be sufficient to ensure that the fundamental emission stays within the authorized frequency block.

VOLTAGE (%)	POWER (V DC)	TEMP (°C)	FREQUENCY (Hz)	FREQ.Dev (Hz)	Deviation	
					(ppm)	(%)
100%	3.80	+25(Ref)	1,880,000,002	2	0.0011	0.000000106
100%		-30	1,880,000,004	4	0.0021	0.000000213
100%		-20	1,880,000,003	3	0.0016	0.000000160
100%		-10	1,879,999,998	-2	-0.0011	-0.000000106
100%		0	1,880,000,007	7	0.0037	0.000000372
100%		+10	1,880,000,003	3	0.0016	0.000000160
100%		+20	1,880,000,004	4	0.0021	0.000000213
100%		+30	1,880,000,005	5	0.0027	0.000000266
100%		+40	1,880,000,002	2	0.0011	0.000000106
100%		+50	1,879,999,997	-3	-0.0016	-0.000000160
115%		4.37	+25	1,879,999,998	-2	-0.0011
BATT.ENDPOINT	3.23	+25	1,879,999,996	-4	-0.0021	-0.000000213

8. TEST PLOTS

Note: All bandwidths, RB configurations, and modulations were investigated. The worst case test results are reported below.

8.1 OCCUPIED BANDWIDTH

8.1.1 LTE Band 17

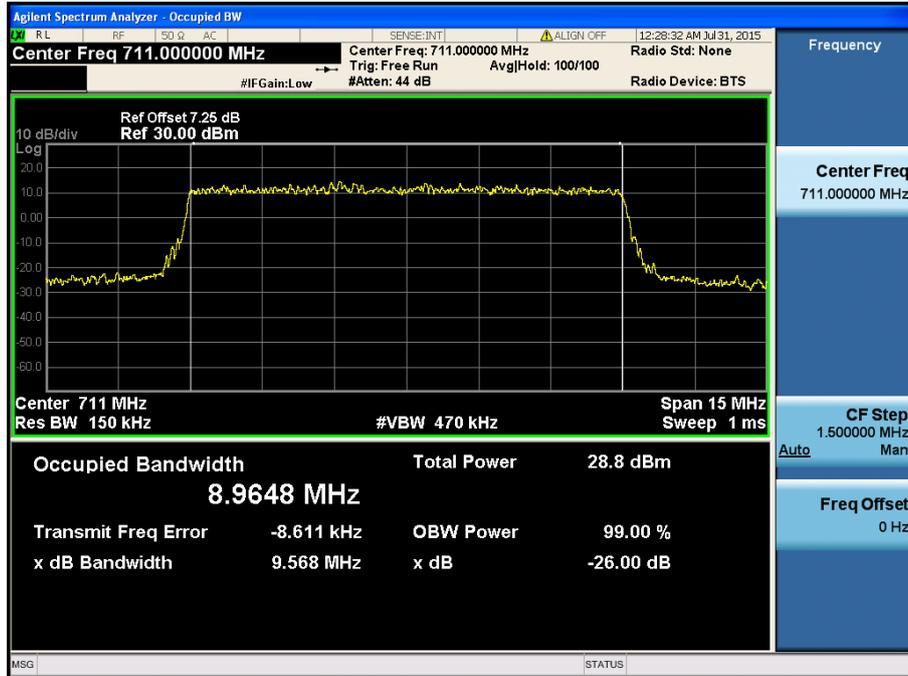

LTE Band 17 / 10 MHz / QPSK - RB Size 50

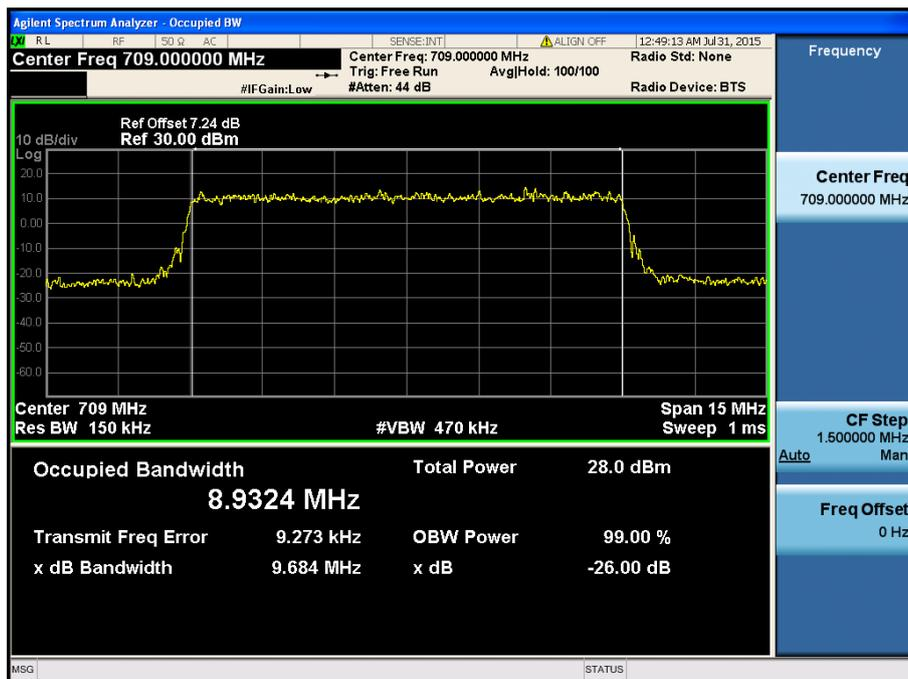

LTE Band 17 / 10 MHz / 16QAM - RB Size 50

8.1.2 LTE Band 5

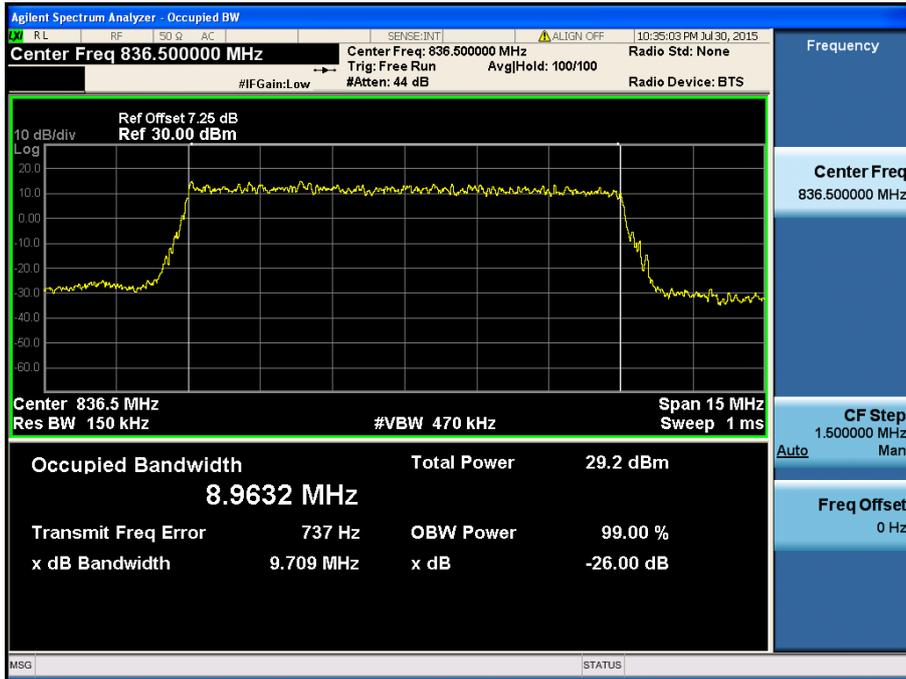

LTE Band 5 / 10 MHz / QPSK - RB Size 50

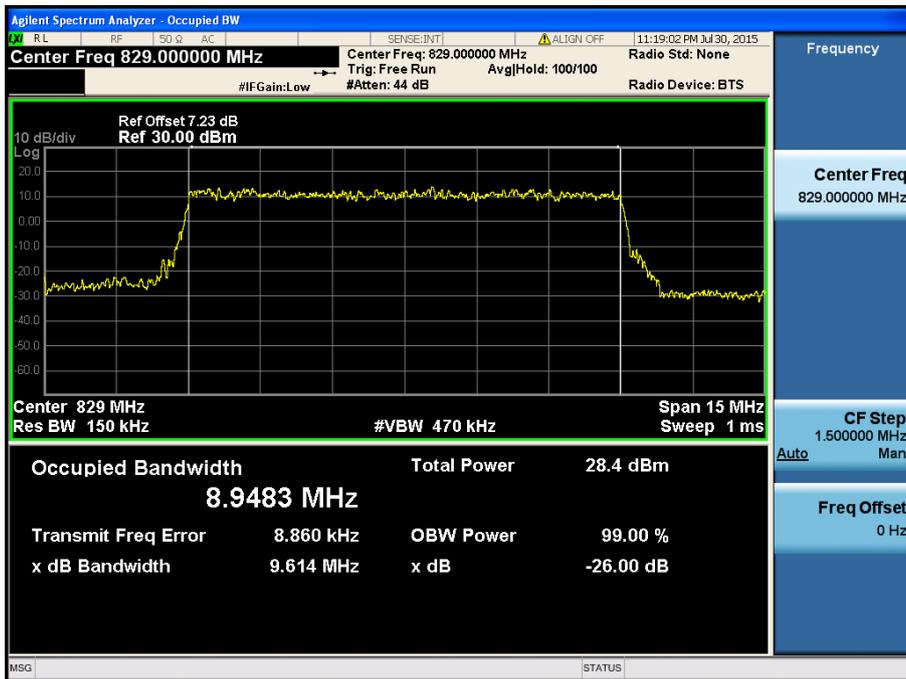

LTE Band 5 / 10 MHz / 16QAM - RB Size 50

8.1.3 LTE Band 4

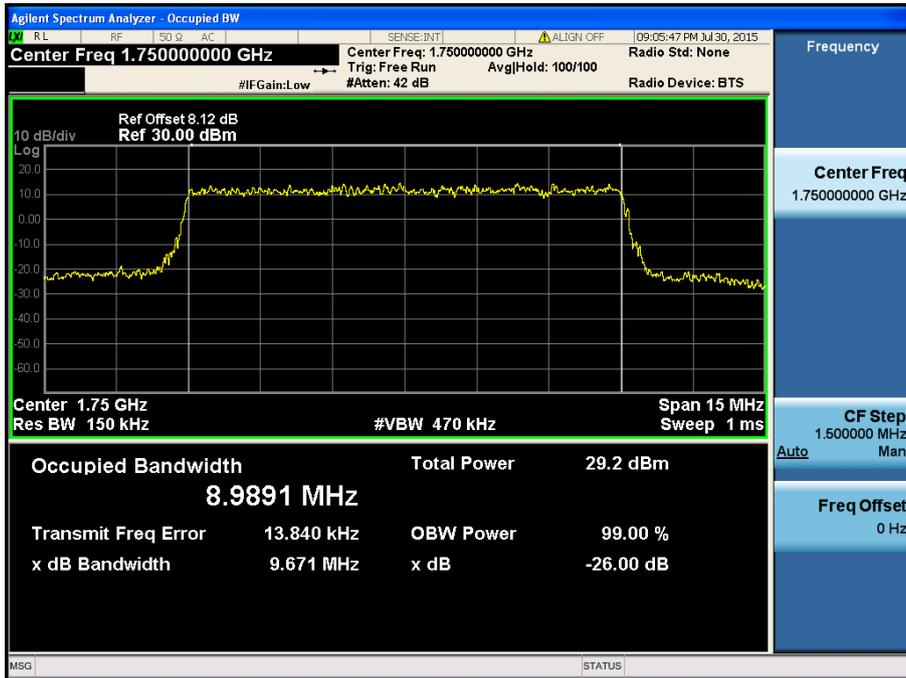

LTE Band 4 / 10 MHz / QPSK - RB Size 50

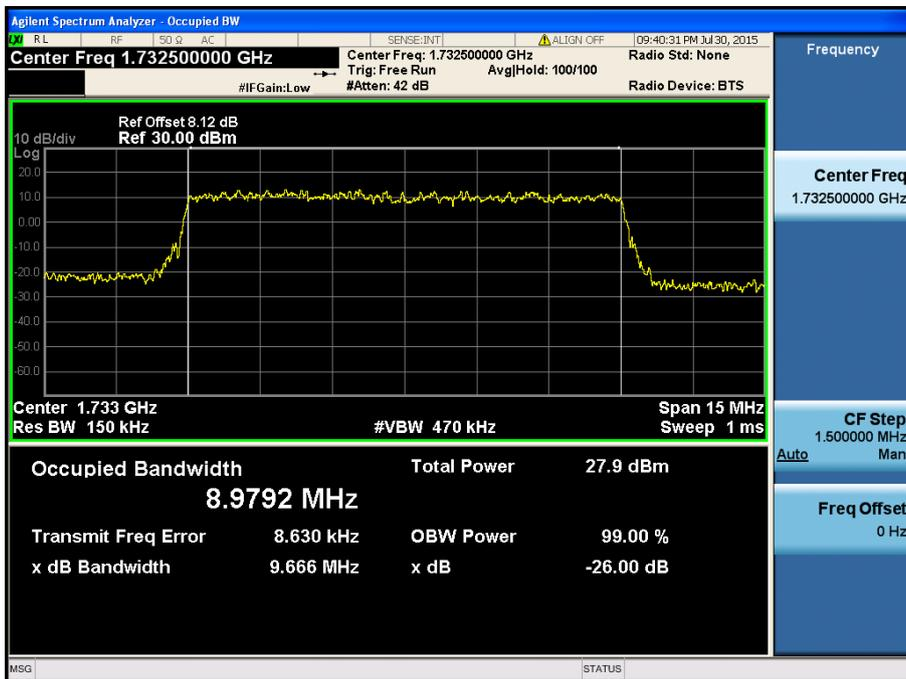

LTE Band 4 / 10 MHz / 16QAM - RB Size 50

8.1.4 LTE Band 2

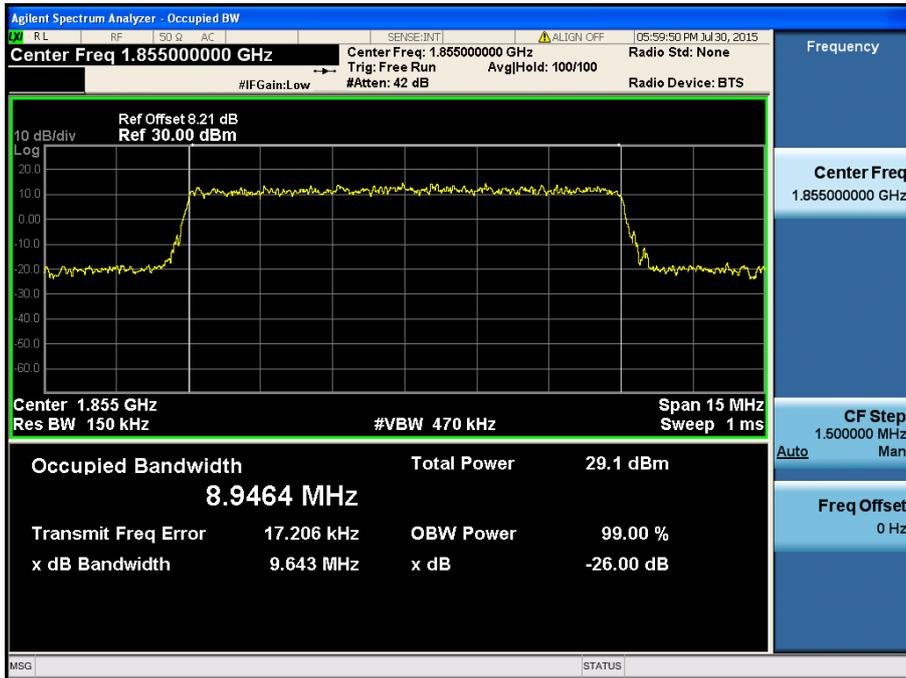

LTE Band 2 / 10 MHz / QPSK - RB Size 50

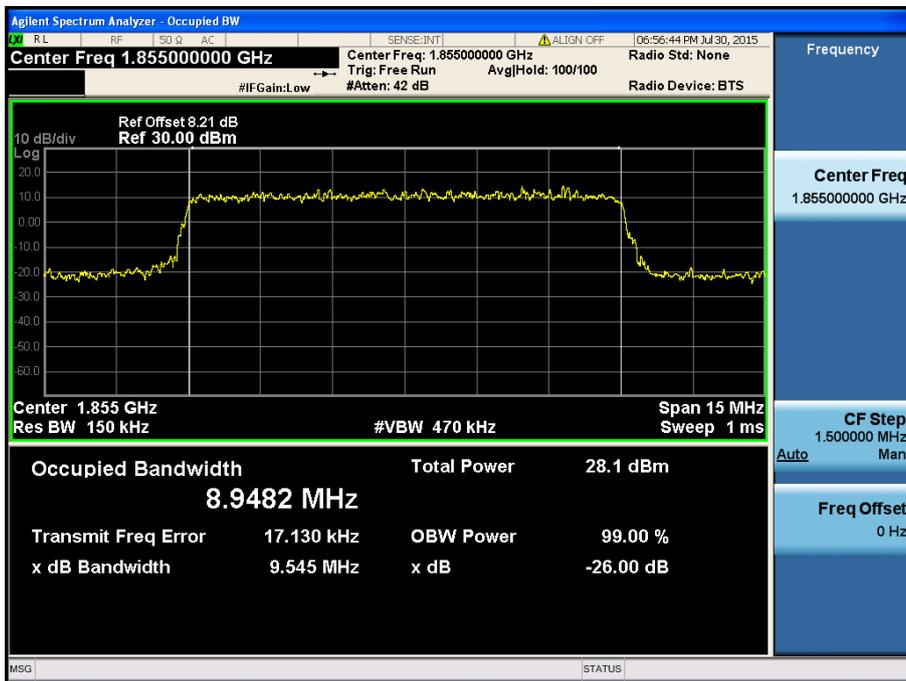

LTE Band 2 / 10 MHz / 16QAM - RB Size 50

8.2 PEAK TO AVERAGE RATIO

8.2.1 LTE Band 4

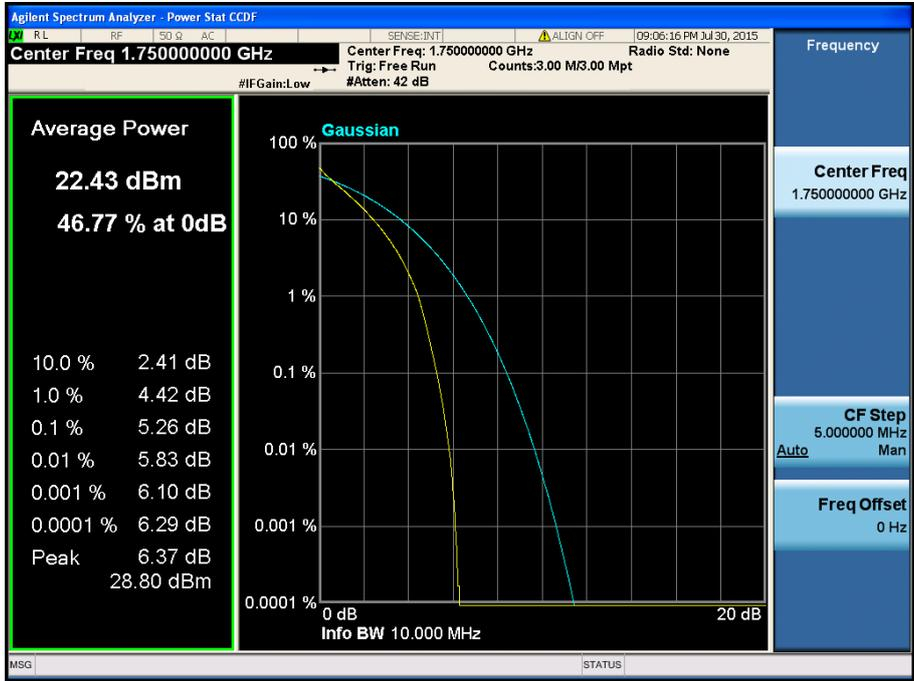

LTE Band 4 / 10 MHz / QPSK - RB Size 50

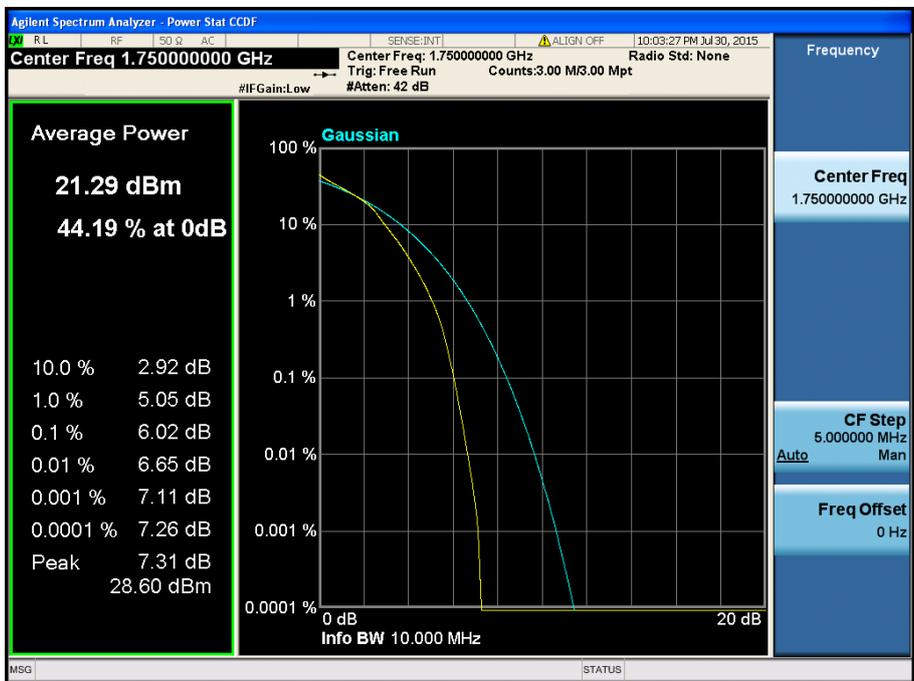

LTE Band 4 / 10 MHz / 16QAM - RB Size 50

8.2.2 LTE Band 2

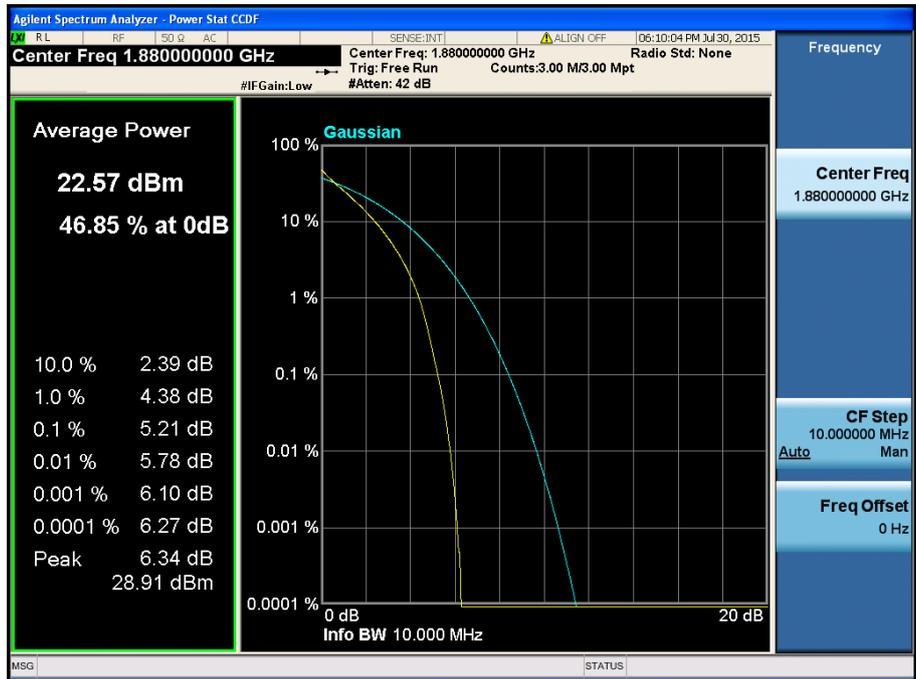

LTE Band 2 / 10 MHz / QPSK - RB Size 50

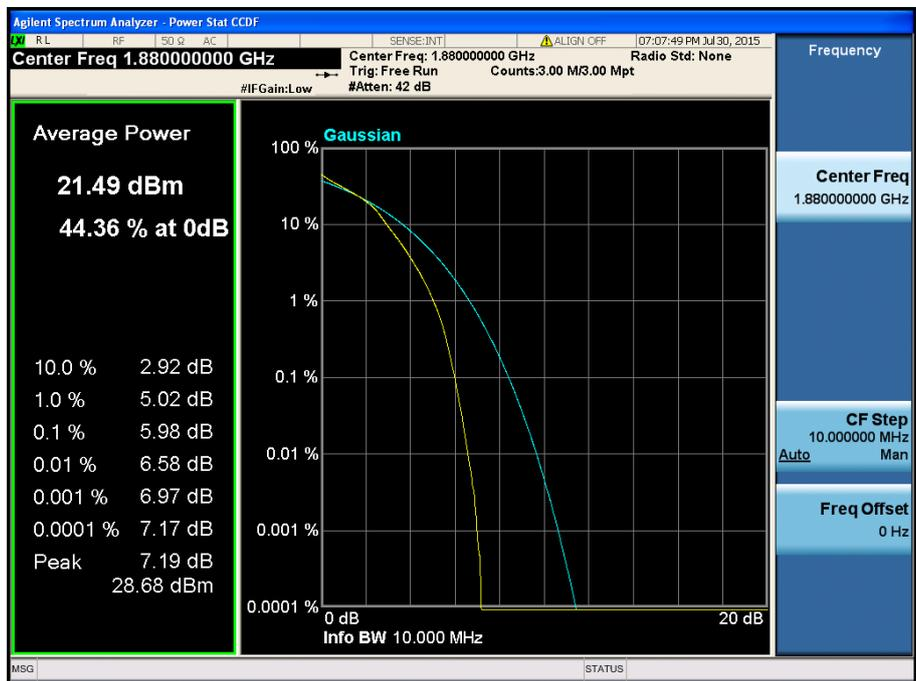

LTE Band 2 / 10 MHz / 16QAM - RB Size 50

- Upper Band Edge

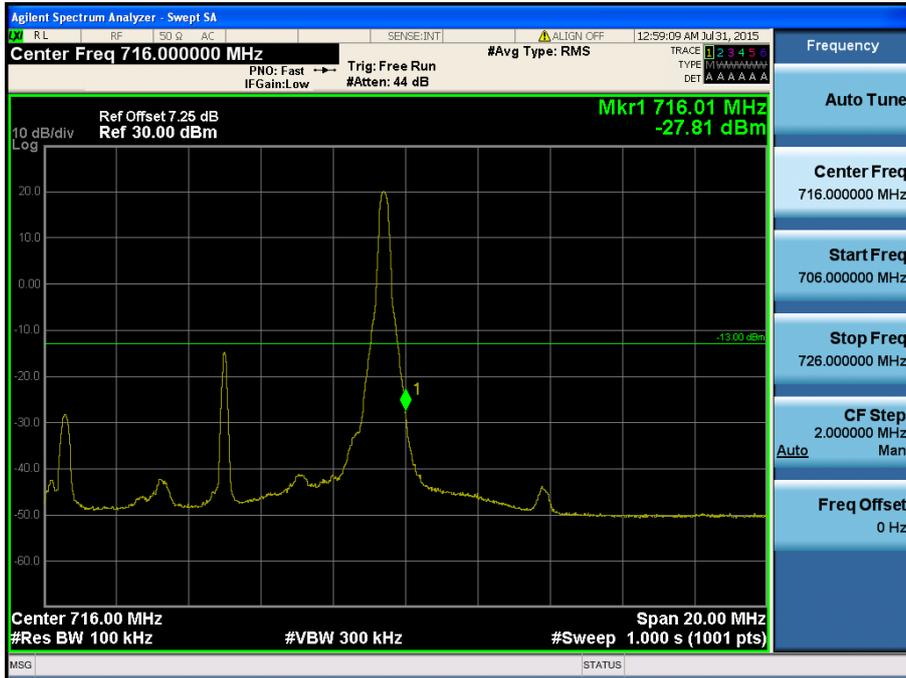

LTE Band 17 / 10MHz / 16QAM - RB Size/Offset (1/49)

- Upper Extended Band Edge



LTE Band 17 / 10MHz / QPSK - RB Size/Offset (50/0)

8.3.2 LTE Band 5

- Lower Band Edge



LTE Band 5 / 10MHz / QPSK - RB Size/Offset (25/0)

- Lower Extended Band Edge



LTE Band 5 / 10MHz / QPSK - RB Size/Offset (50/0)

- Upper Band Edge

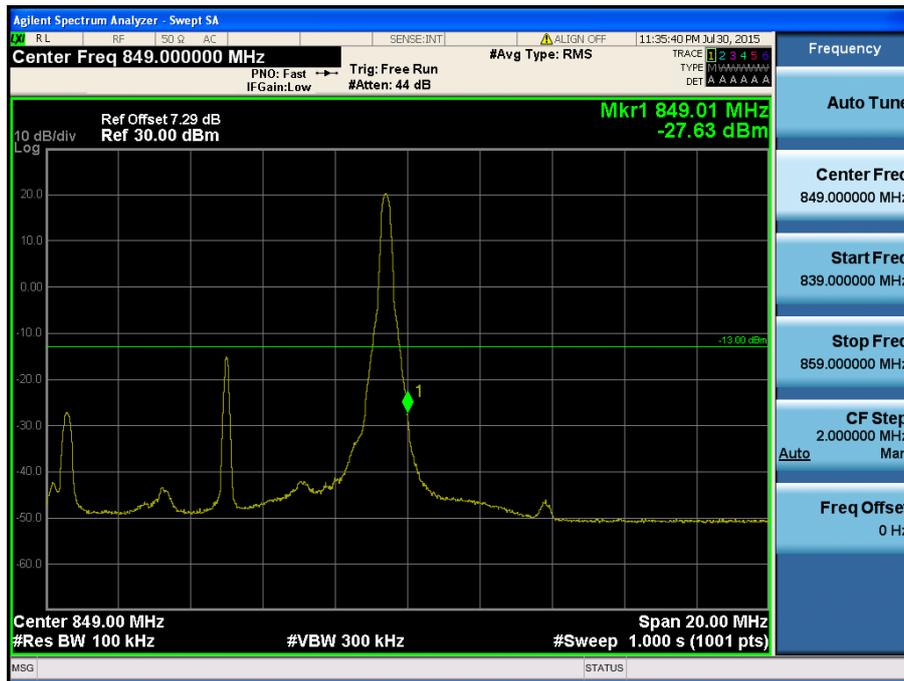

LTE Band 5 / 10MHz / 16QAM - RB Size/Offset (1/49)

- Upper Extended Band Edge



LTE Band 5 / 10MHz / 16QAM - RB Size/Offset (25/25)

8.3.3 LTE Band 4

- Lower Band Edge



LTE Band 4 / 10MHz / QPSK - RB Size/Offset (25/0)

- Lower Extended Band Edge



LTE Band 4 / 10MHz / QPSK - RB Size/Offset (25/0)

- Upper Band Edge



LTE Band 4 / 10MHz / QPSK - RB Size/Offset (25/25)

- Upper Extended Band Edge



LTE Band 4 / 10MHz / QPSK - RB Size/Offset (25/25)

8.3.4 LTE Band 2

- Lower Band Edge



LTE Band 2 / 10MHz / QPSK - RB Size/Offset (25/0)

- Lower Extended Band Edge



LTE Band 2 / 10MHz / QPSK - RB Size/Offset (25/0)

- Upper Band Edge



LTE Band 2 / 10MHz / QPSK - RB Size/Offset (25/25)

- Upper Extended Band Edge



LTE Band 2 / 10MHz / QPSK - RB Size/Offset (25/25)

8.4 SPURIOUS AND HARMONICS EMISSIONS(Conducted)

8.4.1 LTE Band 17

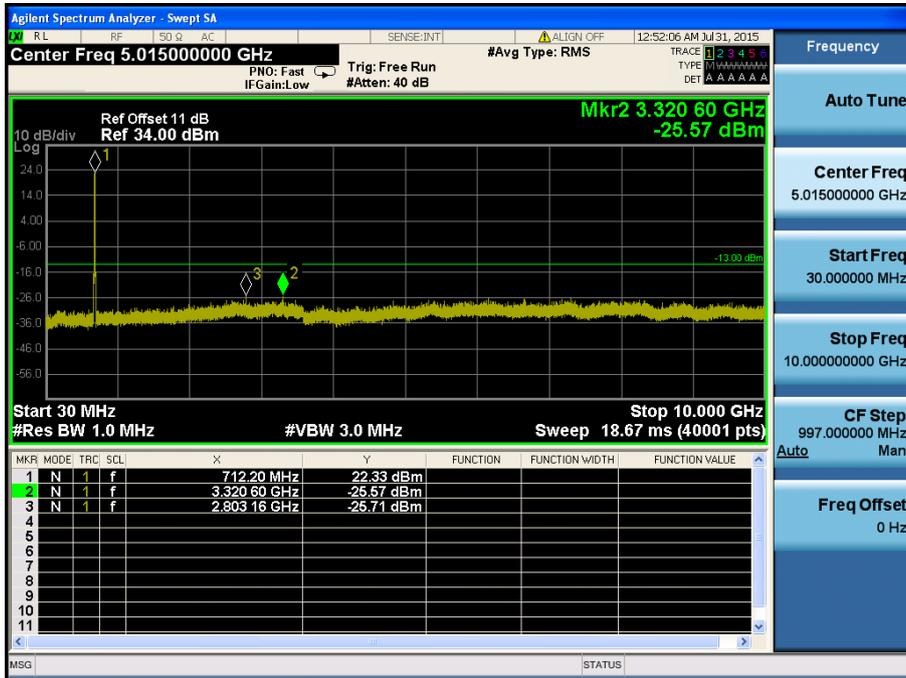

LTE Band 17 / 10MHz / 16QAM - RB Size/Offset (50/0) – Low Channel

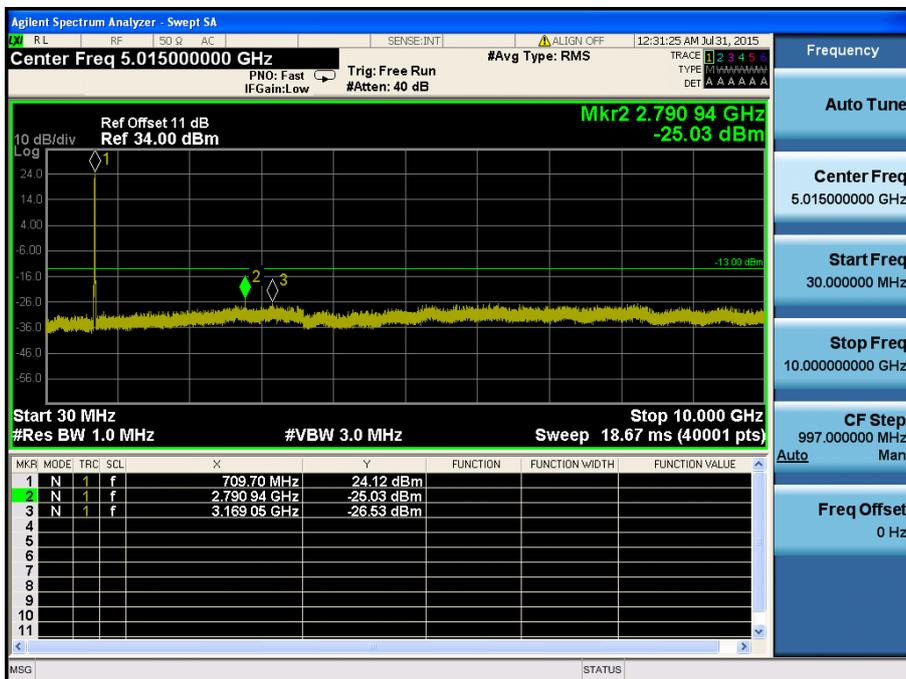

LTE Band 17 / 10MHz / QPSK - RB Size/Offset (50/0) – High Channel

8.4.2 LTE Band 5

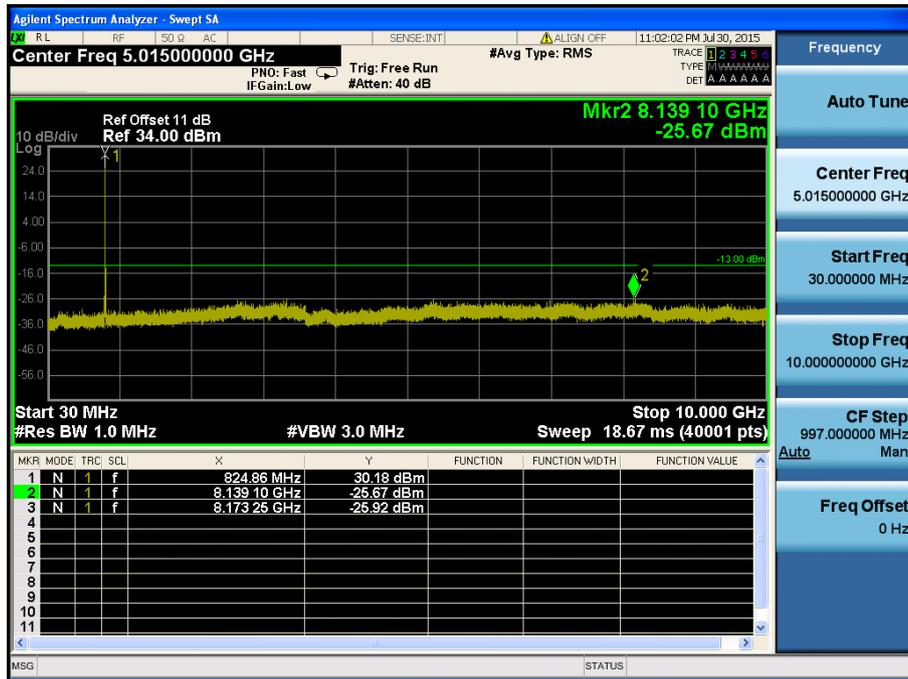

LTE Band 5 / 10MHz / 16QAM - RB Size/Offset (1/0) – Low Channel

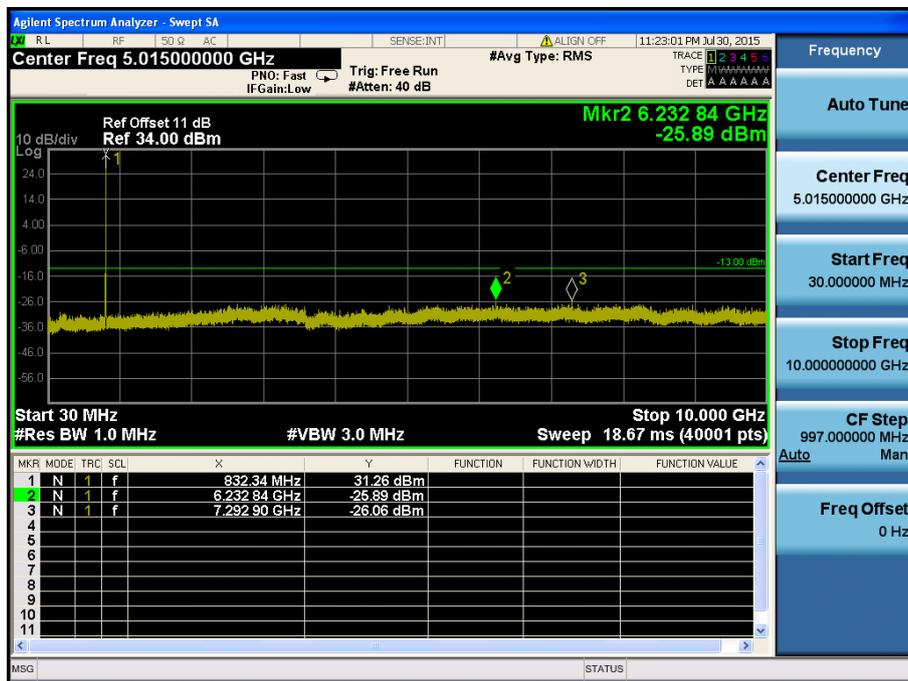

LTE Band 5 / 10MHz / 16QAM - RB Size/Offset (1/0) – Mid Channel

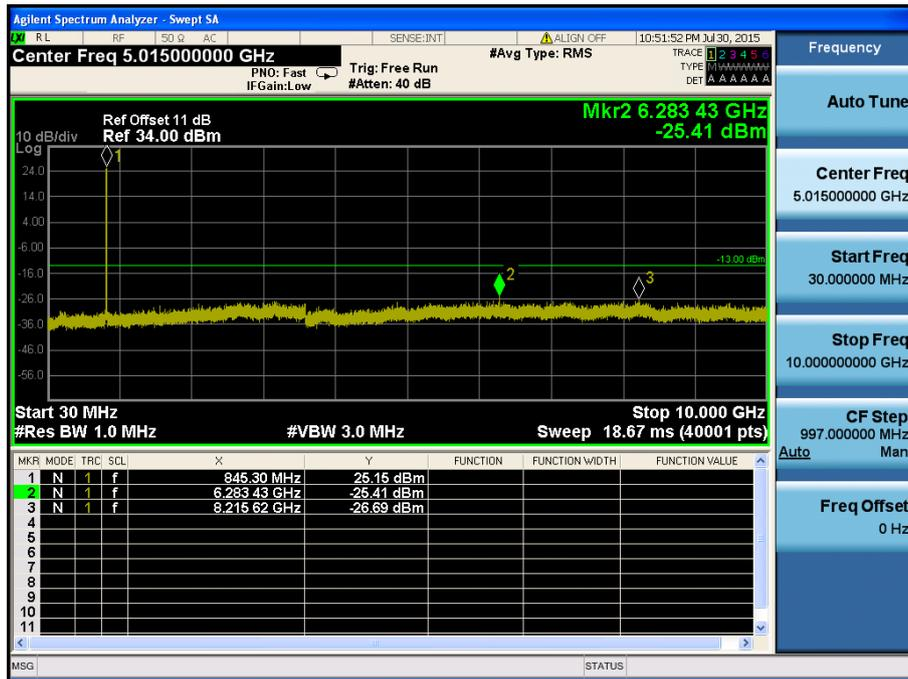

LTE Band 5 / 10MHz / QPSK - RB Size/Offset (25/12) – High Channel

8.4.3 LTE Band 4

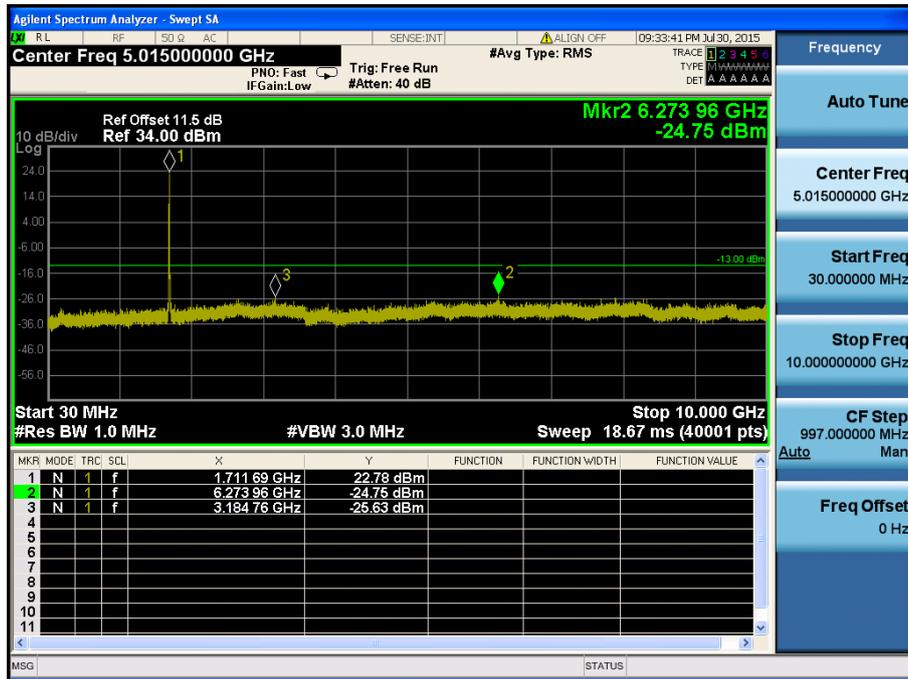

LTE Band 4 / 10MHz / 16QAM - RB Size/Offset (50/0) – Low Channel

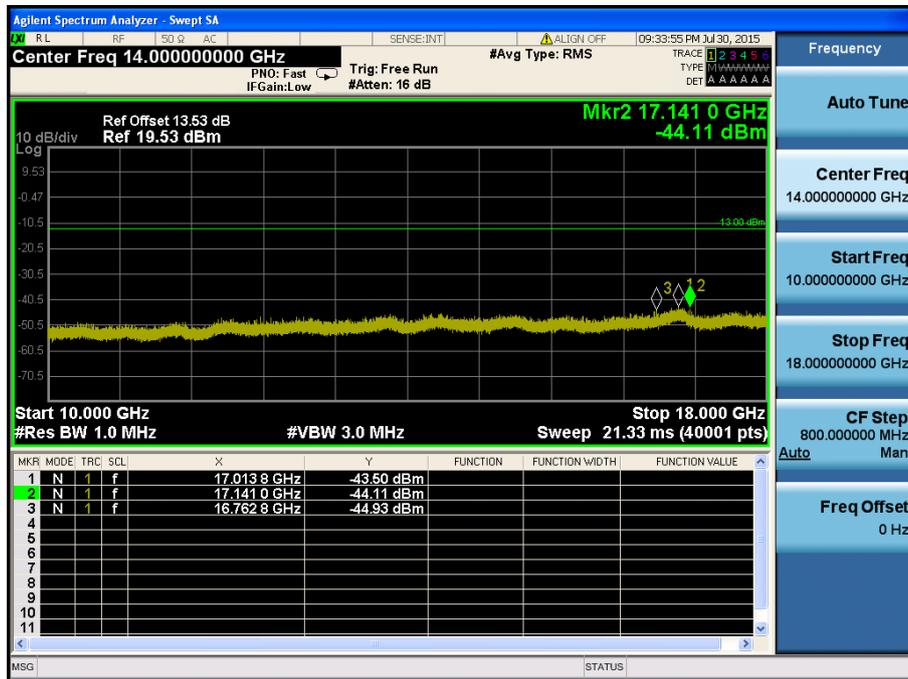

LTE Band 4 / 10MHz / 16QAM - RB Size/Offset (50/0) – Low Channel

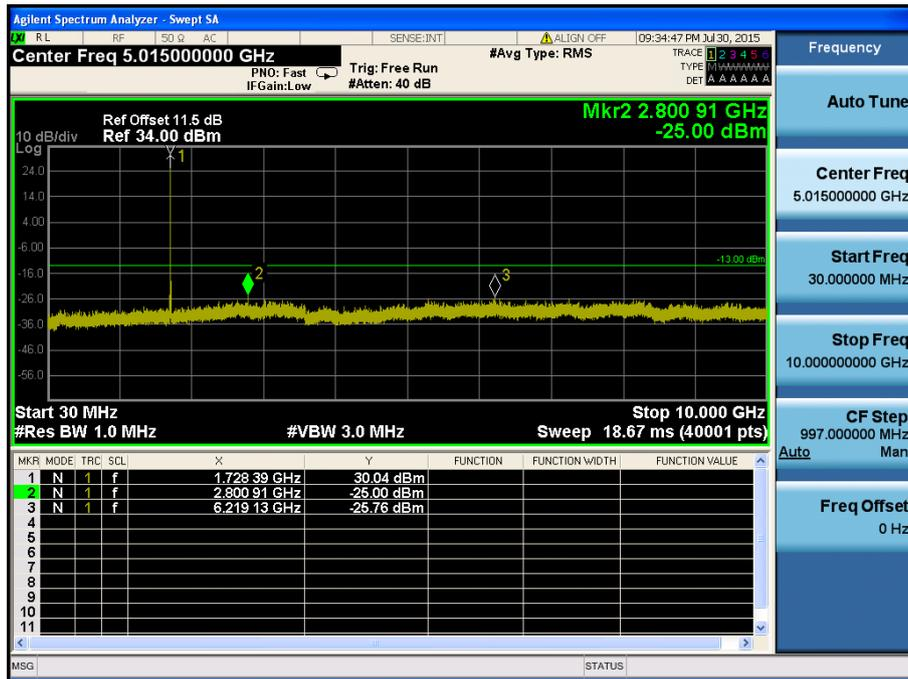

LTE Band 4 / 10MHz / 16QAM - RB Size/Offset (1/0) – Mid Channel

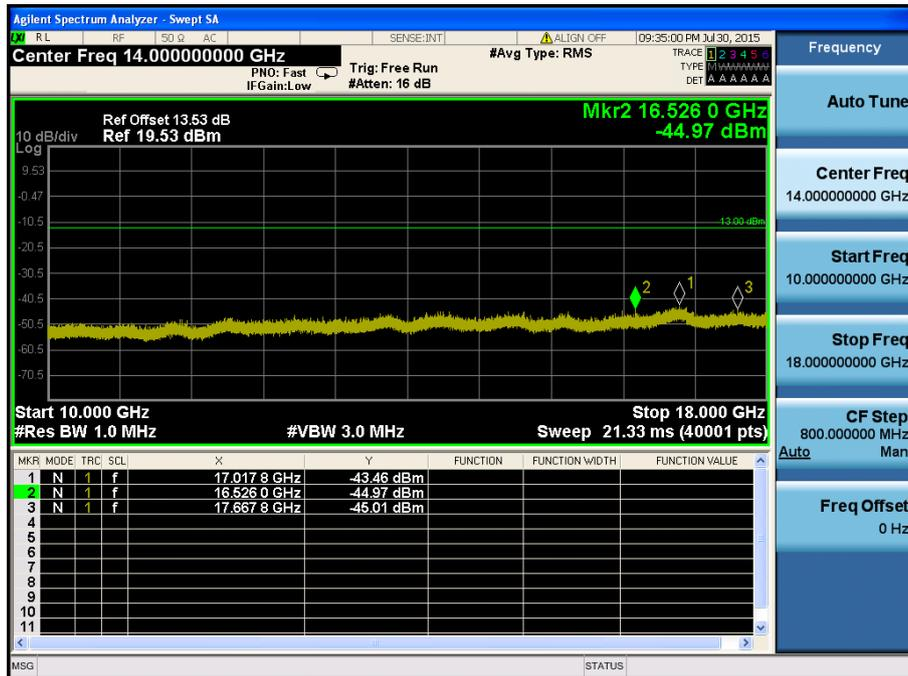

LTE Band 4 / 10MHz / 16QAM - RB Size/Offset (1/0) – Mid Channel

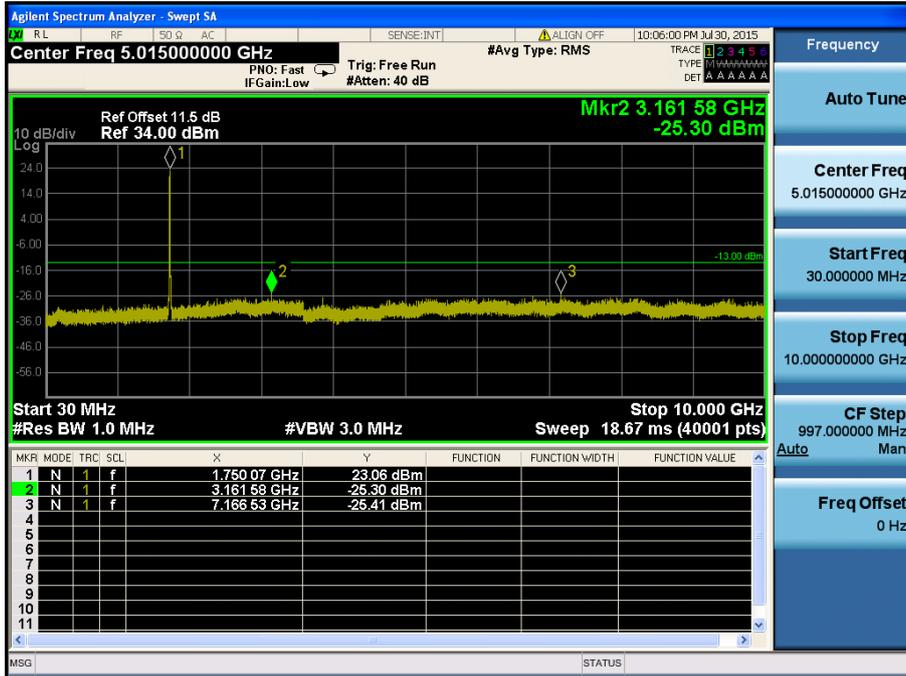

LTE Band 4 / 10MHz / 16QAM - RB Size/Offset (50/0) – High Channel

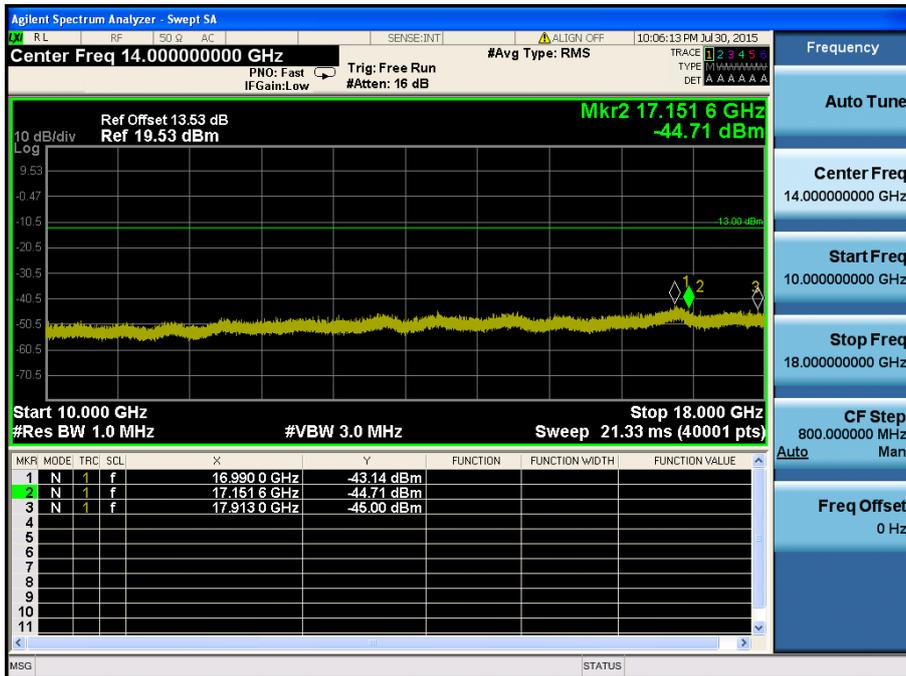

LTE Band 4 / 10MHz / 16QAM - RB Size/Offset (50/0) – High Channel

8.4.4 LTE Band 2

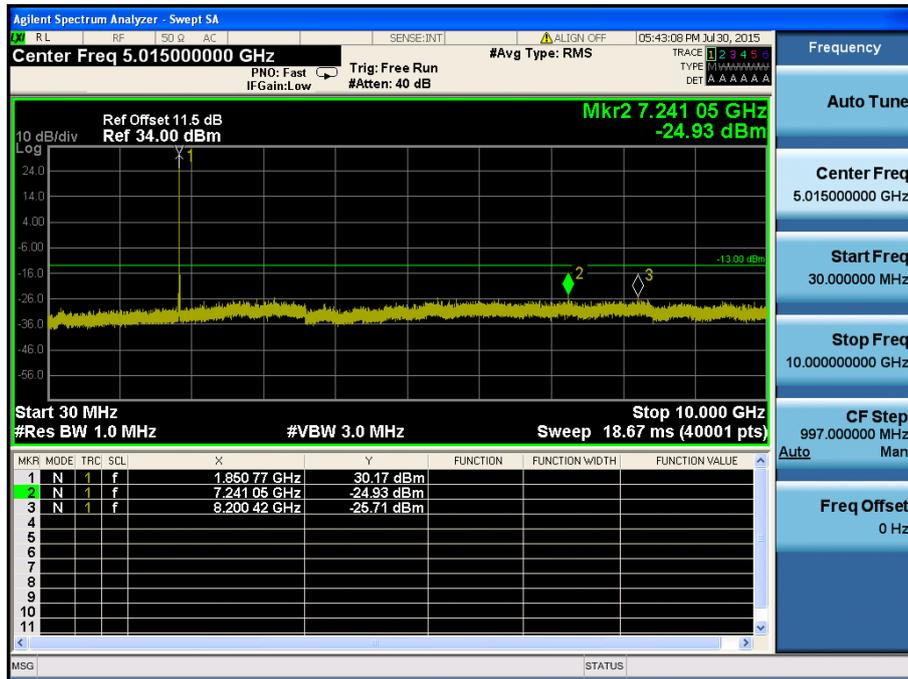

LTE Band 2 / 10MHz / QPSK - RB Size/Offset (1/0) – Low Channel

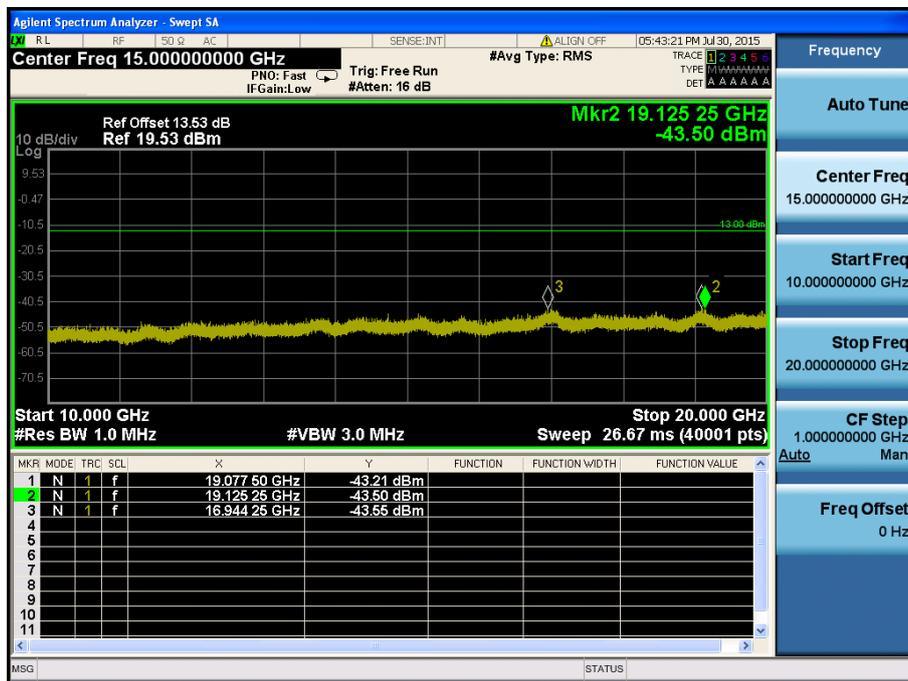

LTE Band 2 / 10MHz / QPSK - RB Size/Offset (1/0) – Low Channel

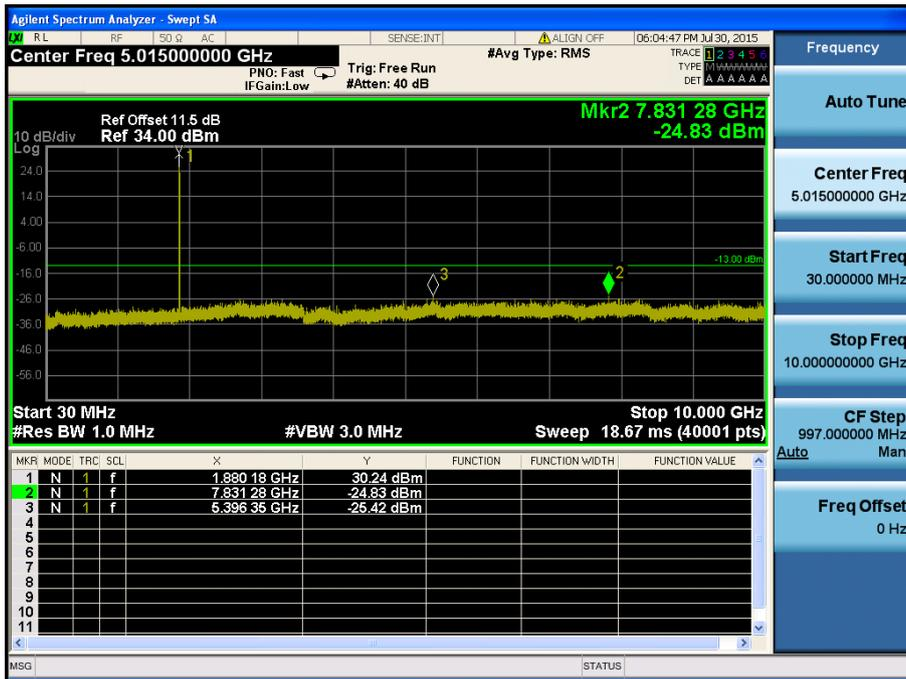

LTE Band 2 / 10MHz / QPSK - RB Size/Offset (1/25) – Mid Channel

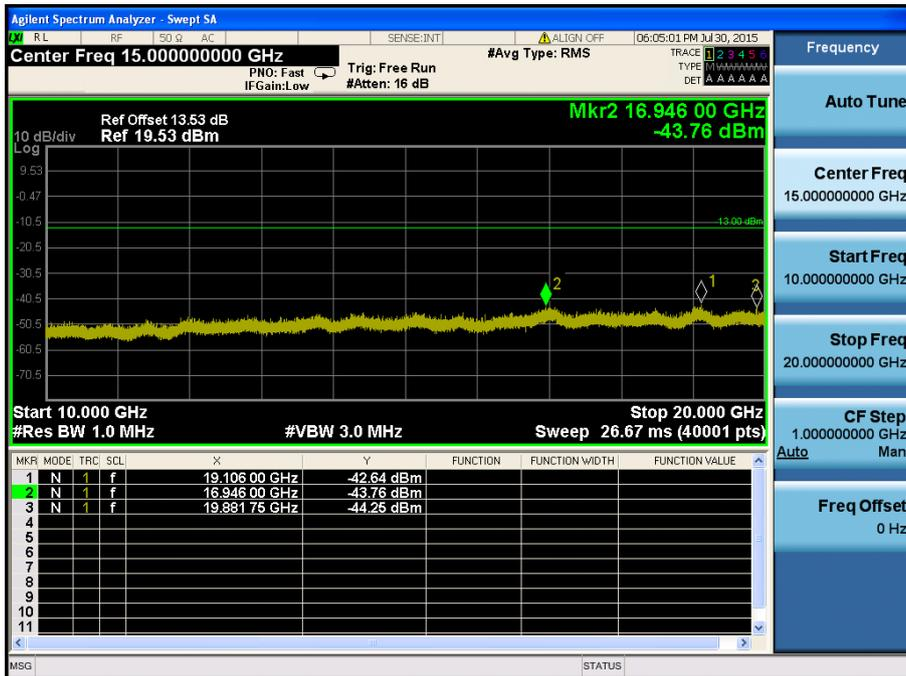

LTE Band 2 / 10MHz / QPSK - RB Size/Offset (1/25) – Mid Channel

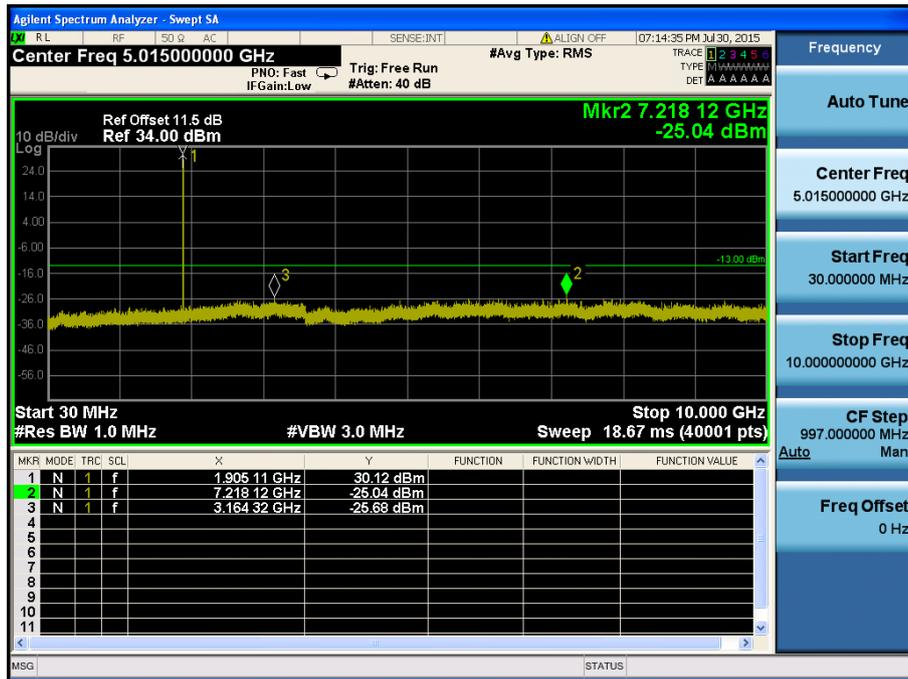

LTE Band 2 / 10MHz / 16QAM - RB Size/Offset (1/25) – High Channel

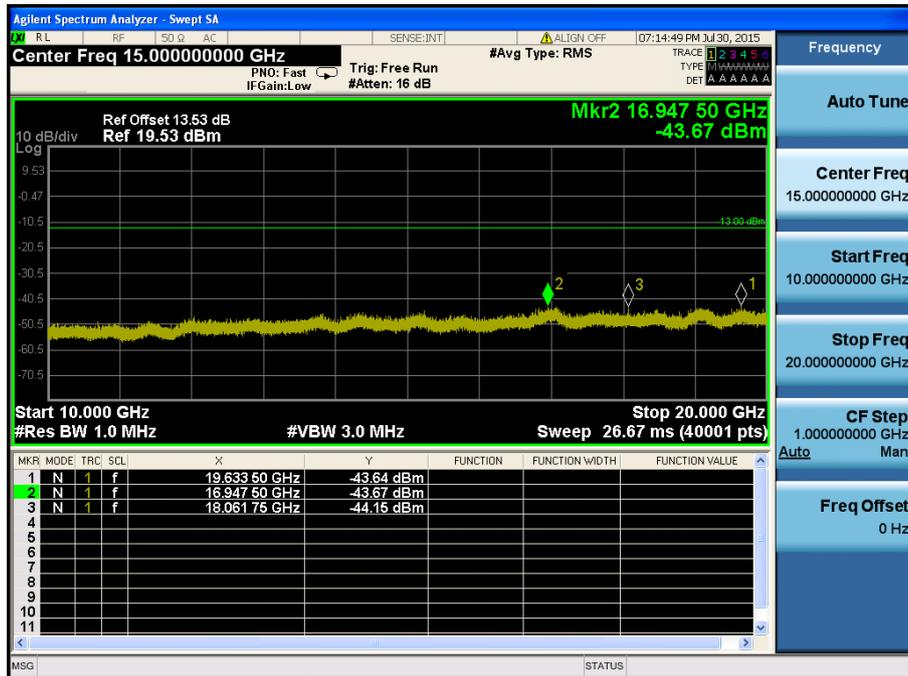

LTE Band 2 / 10MHz / 16QAM - RB Size/Offset (1/25) – High Channel