



243 Jubug-Ri, Yangji-Myeon, Yongin-Si, Gyeonggi-Do, Korea 17159
Tel: +82-31-323-6008 Fax: +82-31-323-6010
<http://www.ltalab.com>

Dates of Tests: Jul 13 ~ Jul 22, 2020
Test Report S/N: LR500142007L
Test Site : LTA CO., LTD.

CERTIFICATION OF COMPLIANCE

FCC ID.

SS4DR901

APPLICANT

Bluebird Inc.

Equipment Class	:	Part 15 Spread Spectrum Transmitter
Manufacturing Description	:	Desktop RFID Reader
Manufacturer	:	Bluebird Inc.
Model name	:	DR901
Test Device Serial No.:	:	Identical prototype
Rule Part(s)	:	FCC Part 15.247 Subpart C ; ANSI C-63.10-2013
Frequency Range	:	917.10 MHz ~ 926.90 MHz(900 MHz RFID)
Max. Output Power	:	Max 24.28 dBm
Data of issue	:	Jul 23, 2020

This test report is issued under the authority of:

The test was supervised by:

Ja-Beom Koo, Manager

Eun-Hwan Jung, Test Engineer

This test result only responds to the tested sample. It is not allowed to copy this report even partly without the allowance of the test laboratory. The report must not be used by the client to claim product certification, approval, or endorsement by NVLAP, NIST, or any agency of the Federal Government.



NVLAP LAB Code.: 200723-0

TABLE OF CONTENTS

1. GENERAL INFORMATION	3
2. INFORMATION ABOUT TEST ITEM	4
3. TEST REPORT	5
3.1 SUMMARY OF TESTS	5
3. TEST REPORT	5
3.1 SUMMARY OF TESTS	5
3.2 FREQUENCY HOPPING SYSTEM REQUIREMENTS	6
3.3 TECHNICAL CHARACTERISTICS TEST	7
3.3.1 CARRIER FREQUENCY SEPARATION	7
3.3.2 NUMBER OF HOPPING FREQUENCIES	8
3.3.3 20 dB BANDWIDTH	9
3.3.4 TIME OF OCCUPANCY (Dwell Time)	10
3.3.5 TRANSMITTER OUTPUT POWER	11
3.3.6 BAND EDGE	12
3.3.7 CONDUCTED SPURIOUS EMISSIONS	13
3.3.8 RADIATED SPURIOUS EMISSIONS	14
3.3.9 AC Conducted Emissions	28
APPENDIX	
APPENDIX TEST EQUIPMENT USED FOR TESTS	29

1. General information

1-1 Test Performed

Company name : LTA Co., Ltd.
 Address : 243, Jubug-ri, Yangji-Myeon, Youngin-Si, Kyunggi-Do, Korea. 449-822
 Web site : <http://www.ltalab.com>
 E-mail : chahn@ltalab.com
 Telephone : +82-31-323-6008
 Facsimile : +82-31-323-6010

Quality control in the testing laboratory is implemented as per ISO/IEC 17025 which is the “General requirements for the competents of calibration and testing laboratory”.

1-2 Accredited agencies

LTA Co., Ltd. is approved to perform EMC testing by the following agencies:

Agency	Country	Accreditation No.	Validity	Reference
NVLAP	U.S.A	200723-0	2020-09-30	ECT accredited Lab.
RRA	KOREA	KR0049	-	EMC accredited Lab.
FCC	U.S.A	649054	2021-04-11	FCC CAB
VCCI	JAPAN	C-4948,	2020-09-10	VCCI registration
VCCI	JAPAN	T-2416,	2020-09-10	VCCI registration
VCCI	JAPAN	R-4483(10 m),	2020-10-15	VCCI registration
VCCI	JAPAN	G-847	2022-06-13	VCCI registration
IC	CANADA	5799A-1	2021-06-16	IC filing
KOLAS	KOREA	NO.551	2021-08-20	KOLAS accredited Lab.

2. Information about test item

2-1 Client & Manufacturer

Company name : Bluebird Inc.
 Address : (Dogok-dong, SEI Tower 13,14) 39,Eonjuro30-gil, Gangnam-gu, Seoul, South Korea
 Tel / Fax : TEL No : +82-010-4093-8861 / FAX No : +82-02-2258-9209
 Model name : DR901

2-2 Equipment Under Test (EUT)

Date of receipt : July 13, 2020
 EUT condition : Pre-production, not damaged
 Antenna type : Patch Antenna
 Frequency Range : 917.10 MHz ~ 926.90 MHz
 RF output power : Max 24.28 dBm
 Number of channels : 50
 Type of Modulation : ASK
 Power Source : DC 5.0 V
 Firmware Version : V1.0.0

2-3 Tested frequency

900MHz RFID	LOW	MID	HIGH
Frequency (MHz)	917.10	921.90	926.90

2-4 Ancillary Equipment

Equipment	Model No.	Serial No.	Manufacturer
Notebook	CR720	MS-1736	MSI

3. Test Report

3.1 Summary of tests

FCC Part Section(s)	Parameter	Limit	Test Condition	Status (note 1)
15.247(a)	Carrier Frequency Separation	$\geq 2/3$ of 20dB BW	Conducted	N/A
15.247(a)	Number of Hopping Frequencies	≥ 15 channels		N/A
15.247(a)	20 dB Bandwidth 99% Bandwidth	–		N/A
15.247(a)	Dwell Time	≤ 0.4 seconds		N/A
15.247(b)	Transmitter Output Power	≤ 1 W for 1Mbps ≤ 125 mW for 2,3Mbps		N/A
15.247(d)	Conducted Spurious emission	> 20 dBc		N/A
15.247(d)	Band Edge	> 20 dBc		N/A
15.249 / 15.209	Field Strength of Harmonics	< 54 dBuV (at 3m)		Radiated
15.109	Field Strength	–	C	
15.207 /15.107	AC Conducted Emissions	EN 55022	Conducted	NA
15.203	Antenna requirement	–	-	C

Note 1: C=Complies NC=Not Complies NT=Not Tested NA=Not Applicable

Note 2: The data in this test report are traceable to the national or international standards.

Note 3: This product is for fixed use.

N/A: The product replaces this test with a certificate using an authenticated module.

→ Antenna Requirement

Bluebird Inc. FCC ID : SS4DR901 unit complies with the requirement of §15.203.

The antenna type is Patch Antenna

The sample was tested according to the following specification:

*FCC Parts 15.247; ANSI C-63.4-2014

*FCC KDB Publication No. 558074 D01 v05r02

*FCC TCB Workshop 2012, April

3.2 Frequency Hopping System Requirements

3.2.1 Standard Applicable

According to FCC Part 15.247(a)(1), The system shall hop to channel frequencies that are selected at the system hopping rate from a pseudo randomly ordered list of hopping frequencies. Each frequency must be used equally on the average by each transmitter. The system receivers shall have input bandwidths that match the hopping channel bandwidths of their corresponding transmitters and shall shift frequencies in synchronization with the transmitted signals.

(g) Frequency hopping spread spectrum systems are not required to employ all available hopping channels during each transmission. However, the system, consisting of both the transmitter and the receiver, must be designed to comply with all of the regulations in this section should the transmitter be presented with a continuous data (or information) stream. In addition, a system employing short transmission bursts must comply with the definition of a frequency hopping system and must distribute its transmissions over the minimum number of hopping channels specified in this section.

(h) The incorporation of intelligence within a frequency hopping spread spectrum system that permits the system to recognize other users within the spectrum band so that it individually and independently chooses and adapts its hopsets to avoid hopping on occupied channels is permitted. The coordination of frequency hopping systems in any other manner for the express purpose of avoiding the simultaneous occupancy of individual hopping frequencies by multiple transmitters is not permitted.

3.3 TECHNICAL CHARACTERISTIC TEST

3.3.1 Carrier Frequency Separation

Procedure:

The test follows ANSI C-63.10. The carrier frequency separation was measured with a spectrum analyzer connected to the antenna terminal, while EUT had its hopping function enabled.

After the trace being stable, the reading value between the peaks of the adjacent channels using the marker-delta function was recorded as the measurement results.

The spectrum analyzer is set to:

Span = 2~ 3 MHz (wide enough to capture the peaks of two adjacent channels)

RBW = 100 kHz (1% of the span or more)

Sweep = auto

VBW = 100 kHz

Detector function = peak

Trace = max hold

Measurement Data: N/A

Minimum Standard:

The EUT shall have hopping channel carrier frequencies separated by a minimum of 25 kHz or two-thirds of 20 dB bandwidth of the hopping channel, whichever is greater.

Measurement Setup

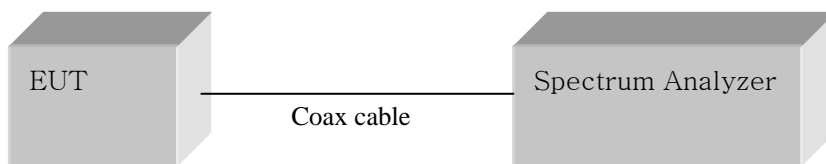

Figure 1: Measurement setup for the carrier frequency separation

3.3.2 Number of Hopping Frequencies

Procedure:

For frequency hopping systems operating in the 902–928 MHz band: if the 20 dB bandwidth of the hopping channel is less than 250 kHz, the system shall use at least 50 hopping frequencies

The spectrum analyzer is set to (Bluetooth):

Frequency range Start = 802 MHz, Stop = 928 MHz

RBW = 100 kHz (1% of the span or more) Sweep = auto

e)

VBW = 100 kHz (VBW \geq RBW)

Detector function = peak

Trace = max hold

Span > 40 MHz

Measurement Data : N/A

Minimum Standard:

Have at least 50 channels below 250 kHz bandwidth

Measurement Setup

Same as the Chapter 3.3.1 (Figure 1)

3.3.3 20 dB Bandwidth

Procedure:

The bandwidth at 20 dB below the highest inband spectral density was measured with a spectrum analyzer connected to the antenna terminal, while EUT had its hopping function disabled at the highest, middle and the lowest available channels..

After the trace being stable, Use the marker-to-peak function to set the marker to the peak of the emission. Use the marker-delta function to measure 20 dB down one side of the emission. Reset the marker-delta function, and move the marker to the other side of the emission, until it is (as close as possible to) even with the reference marker level. The marker-delta reading at this point is the 20 dB bandwidth of the emission.

The spectrum analyzer is set to RFID :

Center frequency = the highest, middle and the lowest channels

Span = 3 MHz (approximately 2 or 3 times of the 20 dB bandwidth)

RBW = 30 kHz

Sweep = auto

VBW = 30 kHz (VBW \geq RBW)

Detector function = peak

Trace = max hold

Measurement Data: N/A

Minimum Standard:

N/A

Measurement Setup

Same as the Chapter 3.3.1 (Figure 1)

3.3.4 Time of Occupancy (Dwell Time)

Procedure:

The test follows ANSI C-63.10. The dwell time was measured with a spectrum analyzer connected to the antenna terminal, while EUT had its hopping function enabled.

The spectrum analyzer is set to :

Center frequency = 915 MHz

Span = zero

RBW = 1 MHz

VBW = 1 MHz (VBW \geq RBW)

Trace = max hold

Detector function = peak

Measurement Data (RFID): N/A

Minimum Standard:

the average time of occupancy on any frequency shall not be greater than 0.4 seconds within a 20 second period

Measurement Setup

Same as the Chapter 3.3.1 (Figure 1)

3.3.5 Transmitter Output Power

Procedure:

The test follows ANSI C-63.10. The peak output power was measured with a spectrum analyzer connected to the antenna terminal, while EUT had its hopping function disabled at the highest, middle and the lowest available channels..

After the trace being stable, Use the marker-to-peak function to set the marker to the peak of the emission. The indicated level is the peak output power.

The spectrum analyzer is set to :

Center frequency = the highest, middle and the lowest channels

Span = 10 MHz (approximately 5 times of the 20 dB bandwidth)

RBW = 3 MHz (greater than the 20 dB bandwidth of the emission being measured)

VBW = 3 MHz (VBW \geq RBW)

Detector function = peak

Trace = max hold

Sweep = auto

Measurement Data : N/A

Minimum Standard:	at least 1 W.
--------------------------	---------------

Measurement Setup

Same as the Chapter 3.3.1 (Figure 1)

3.3.6 Band Edge

Procedure:

The bandwidth at 20 dB down from the highest inband spectral density is measured with a spectrum analyzer connected to the antenna terminal, while EUT had its hopping function disabled at the highest, middle and the lowest available channels.

After the trace being stable, Use the marker-to-peak function to measure 20 dB down both sides of the intentional emission.

The spectrum analyzer is set to:

Center frequency = the highest, middle and the lowest channels

RBW = 100 kHz

VBW = 300 kHz

Span = 10~30 MHz

Detector function = peak

Trace = max hold

Sweep = auto

Measurement Data: N/A

Minimum Standard:	≤ 20 dBc
--------------------------	---------------

Measurement Setup

Same as the Chapter 3.3.1 (Figure 1)

3.3.7 Conducted Spurious Emissions

Procedure:

The test follows ANSI C-63.10. The conducted spurious emissions were measured with a spectrum analyzer connected to the antenna terminal, while EUT had its hopping function disabled at the highest, middle and the lowest available channels..

After the trace being stable, set the marker on the peak of any spurious emission recorded.

The spectrum analyzer is set to:

Span = wide enough to capture the peak level of the in-band emission and all spurious emissions

RBW = 100 kHz

Sweep = auto

VBW = 100 kHz

Detector function = peak

Trace = max hold

Measurement Data: N/A

Minimum Standard:	≤ 20 dBc
--------------------------	---------------

Measurement Setup

Same as the Chapter 3.3.1 (Figure 1)

3.3.8 Radiated Spurious Emissions

Procedure:

The EUT was placed on a 0.8 m high wooden table inside a shielded enclosure. An antenna was placed near the EUT and measurements of frequencies and amplitudes of field strengths were recorded for reference during final measurements. For final radiated testing, measurements were performed in OATS. Measurements were performed with the EUT oriented in 3 orthogonal axis and rotated 360 degrees to determine worst-case orientation for maximum emissions.

The spectrum analyzer is set to:

Center frequency = the worst channel

Frequency Range = 9 kHz ~ 10th harmonic.

RBW = 100 kHz (30 MHz ~ 1 GHz)

VBW \geq RBW

= 1 MHz (1 GHz ~ 10th harmonic)

Span = 100 MHz

Detector function = peak

Trace = max hold

Sweep = auto

Note : Attach worst-case data in accordance with ANSI C63.10-2013 6.3.4.

below 30 MHz

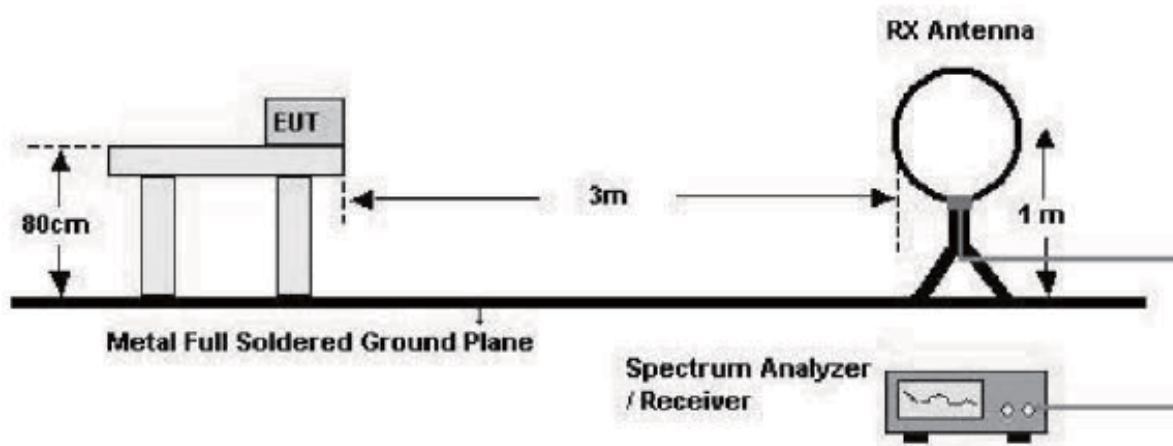

below 1 GHz (30 MHz to 1 GHz)

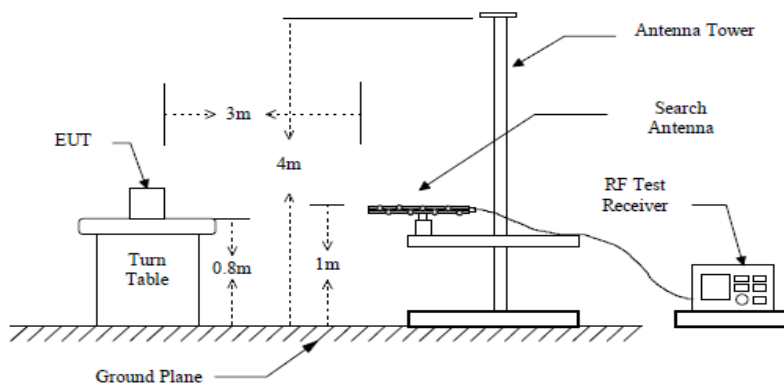

above 1 GHz

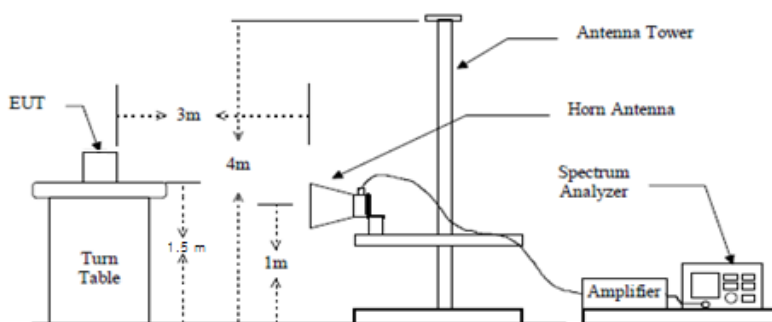

Measurement Data: **Complies**

- See next pages for actual measured data.
- No other emissions were detected at a level greater than 20 dB below limit include from 9 kHz to 30 MHz.
- Checked with a red circle is the fundamental frequency.

Minimum Standard: FCC Part 15.209(a)

Frequency (MHz)	Limit (uV/m) @ 3 m
0.009 ~ 0.490	2400/F(kHz) (@ 300 m)
0.490 ~ 1.705	24000/F(kHz) (@ 30 m)
1.705 ~ 30	30(@ 30 m)
30 ~ 88	100 **
88 ~ 216	150 **
216 ~ 960	200 **
Above 960	500

** Except as provided in 15.209(g), fundamental emissions from intentional radiators operating under this Section shall not be located in the frequency bands 54-72 MHz, 76-88 MHz, 174-216 MHz or 470-806 MHz. However, operation within these frequency bands is permitted under other sections of this Part, e.g. 15.231 and 15.241.

Radiated Emissions



4, Songjuro 236Beon-gil, yanggi-myeon,
 Yongin-si, Gyeonggi-do, Korea
 Tel : +82-31-3236008,9
 Fax : +82-31-3236010
 www.ltalab.com

EUT/Model No.: DR901

Temp/Humi: 23 °C / 55 % R.H.

Test Mode : Operating mode_L

Tested by: JUNG E H

Power :

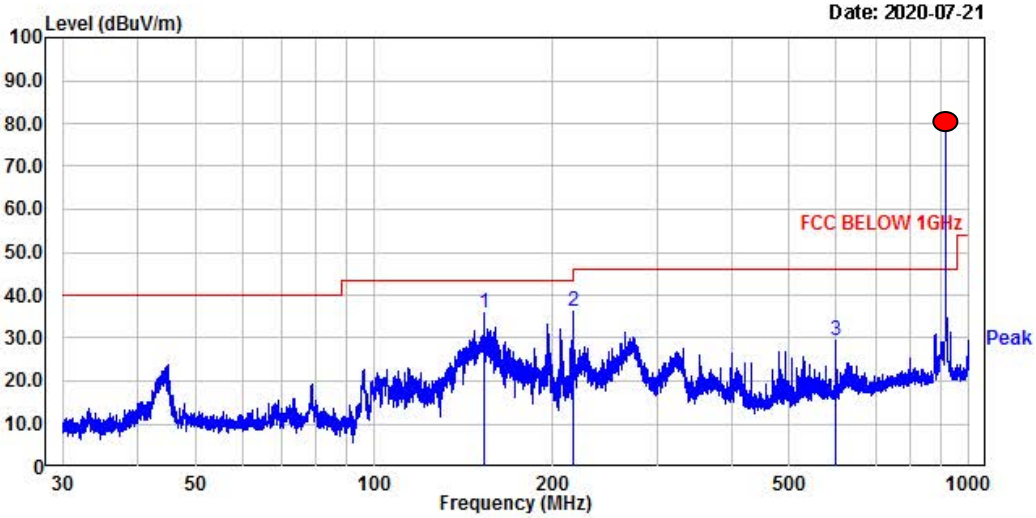

No.	Freq MHz	Reading dBµV	C.F dB	Result QP dBµV/m	Limit dBµV/m	Margin dB	Height cm	Angle deg	Polarity
1.	153.60	50.53	-14.77	35.76	43.50	7.74	100	223	horizontal
2.	216.50	53.44	-17.15	36.29	46.00	9.71	100	92	horizontal
3.	600.11	38.41	-9.05	29.36	46.00	16.64	100	294	horizontal

Remarks: C.F (Correction Factor) = Antenna factor + Cable loss - Preamp gain



4, Songjuro 236Beon-gil, yanggi-myeon,
 Yongin-si, Gyeonggi-do, Korea
 Tel : +82-31-3236008,9
 Fax : +82-31-3236010
 www.ltalab.com

EUT/Model No.: DR901
 Temp/Humi: 23 °C / 55 % R.H.
 Test Mode : Operating mode_L
 Tested by: JUNG E H
 Power :

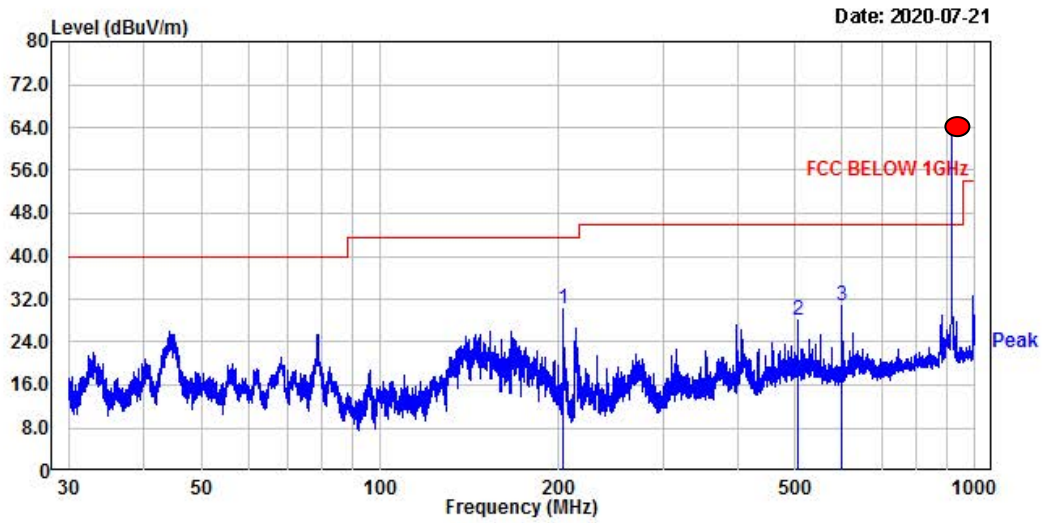

No.	Freq MHz	Reading dBμV	C.F dB	Result QP dBμV/m	Limit dBμV/m	Margin dB	Height cm	Angle deg	Polarity
1.	202.81	47.89	-17.77	30.12	43.50	13.38	100	196	vertical
2.	504.04	39.24	-11.04	28.20	46.00	17.80	100	257	vertical
3.	600.11	39.76	-9.05	30.71	46.00	15.29	100	20	vertical

Remarks: C.F (Correction Factor) = Antenna factor + Cable loss - Preamp gain



4, Songjuro 236Beon-gil, yanggi-myeon,
 Yongin-si, Gyeonggi-do, Korea
 Tel : +82-31-3236008,9
 Fax : +82-31-3236010
 www.ltalab.com

EUT/Model No.: DR901 Temp/Humi: 23 °C / 55 % R.H.
 Test Mode : Operating mode_M Tested by: JUNG E H
 Power : -----

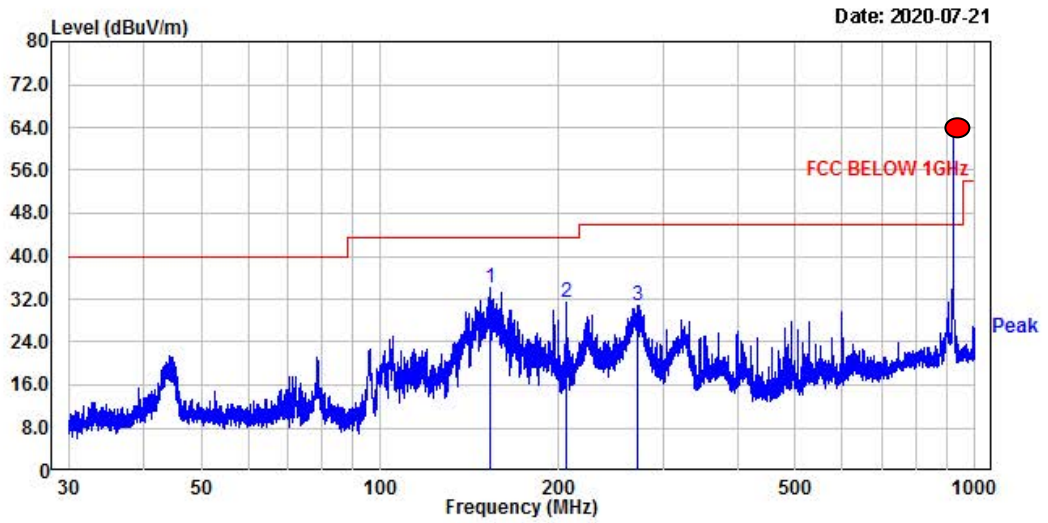

No.	Freq MHz	Reading dBμV	C.F dB	Result QP dBμV/m	Limit dBμV/m	Margin dB	Height cm	Angle deg	Polarity
1.	153.60	48.89	-14.77	34.12	43.50	9.38	100	236	horizontal
2.	205.40	49.17	-17.65	31.52	43.50	11.98	100	143	horizontal
3.	270.61	45.75	-14.90	30.85	46.00	15.15	100	272	horizontal

Remarks: C.F (Correction Factor) = Antenna factor + Cable loss - Preamp gain



4, Songjuro 236Beon-gil, yanggi-myeon,
 Yongin-si, Gyeonggi-do, Korea
 Tel : +82-31-3236008,9
 Fax : +82-31-3236010
 www.ltalab.com

EUT/Model No.: DR901
 Temp/Humi: 23 °C / 55 % R.H.
 Test Mode : Operating mode_M
 Tested by: JUNG E H
 Power :

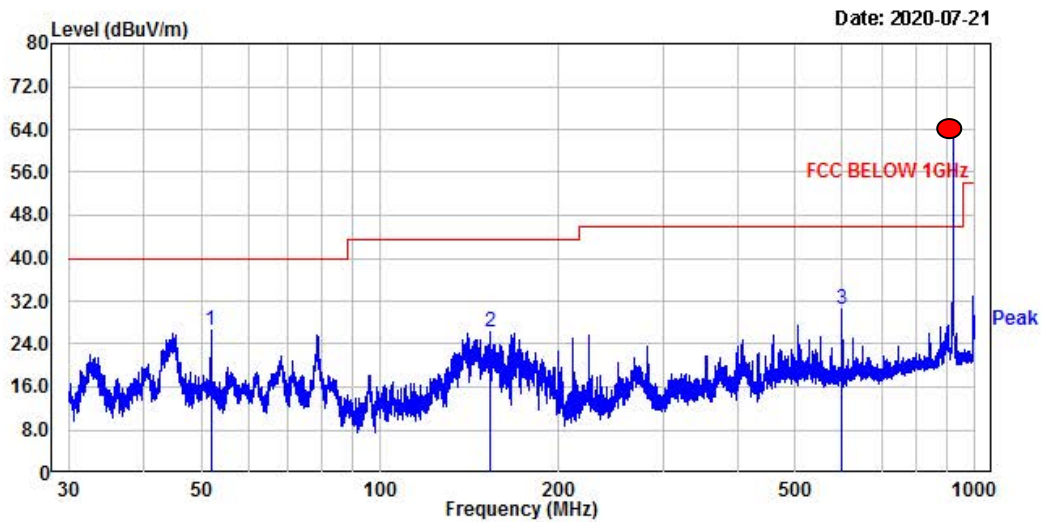

No.	Freq MHz	Reading dBμV	C.F dB	Result QP dBμV/m	Limit dBμV/m	Margin dB	Height cm	Angle deg	Polarity
1.	51.91	41.37	-14.74	26.63	40.00	13.37	400	360	vertical
2.	153.60	41.07	-14.77	26.30	43.50	17.20	100	46	vertical
3.	600.11	39.55	-9.05	30.50	46.00	15.50	100	173	vertical

Remarks: C.F (Correction Factor) = Antenna factor + Cable loss - Preamp gain



4, Songjuro 236Beon-gil, yanggi-myeon,
 Yongin-si, Gyeonggi-do, Korea
 Tel : +82-31-3236008,9
 Fax : +82-31-3236010
 www.ltalab.com

EUT/Model No.: DR901
 Temp/Humi: 23 °C / 55 % R.H.
 Test Mode : Operating mode_H
 Tested by: JUNG E H
 Power :

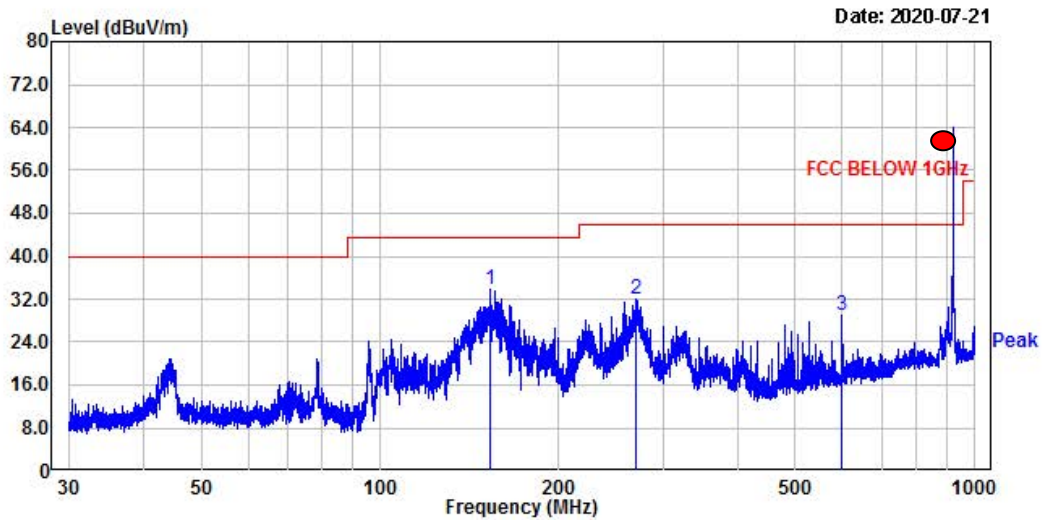

No.	Freq MHz	Reading dBμV	C.F dB	Result QP dBμV/m	Limit dBμV/m	Margin dB	Height cm	Angle deg	Polarity
1.	153.60	48.56	-14.77	33.79	43.50	9.71	100	211	horizontal
2.	270.37	47.06	-14.92	32.14	46.00	13.86	100	260	horizontal
3.	600.11	38.04	-9.05	28.99	46.00	17.01	100	283	horizontal

Remarks: C.F (Correction Factor) = Antenna factor + Cable loss - Preamp gain



4, Songjuro 236Beon-gil, yanggi-myeon,
 Yongin-si, Gyeonggi-do, Korea
 Tel : +82-31-3236008,9
 Fax : +82-31-3236010
 www.ltalab.com

EUT/Model No.: DR901
 Temp/Humi: 23 °C / 55 % R.H.
 Test Mode : Operating mode_L
 Tested by: JUNG E H
 Power :

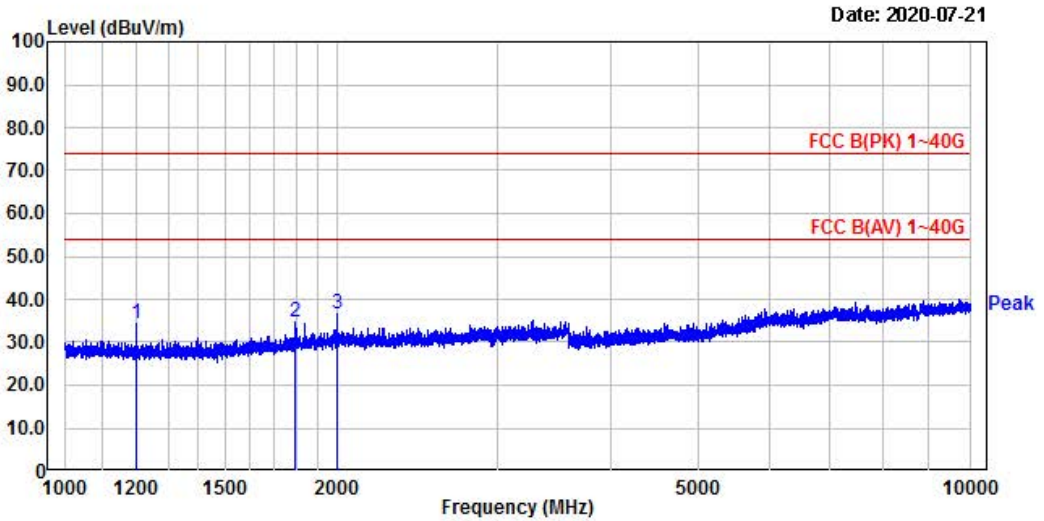

No.	Freq MHz	RD PK dBμV	RD AV dBμV	C.F dB	Result PK dBμV	Result AV dBμV	Limit PK dBμV	Limit AV dBμV	Margin PK dB	Margin AV dB	Height cm	Angle deg	Polarity
1.	1199.15	44.87	-----	-10.70	34.17	-----	74.00	-----	39.83	-----	100	209	horizontal
2.	1794.73	42.10	-----	-7.29	34.81	-----	74.00	-----	39.19	-----	100	222	horizontal
3.	1999.86	42.48	-----	-5.65	36.79	-----	74.00	-----	37.21	-----	100	198	horizontal

Remarks: C.F (Correction Factor) = Antenna factor + Cable loss - Preamp gain



4, Songjuro 236Beon-gil, yanggi-myeon,
 Yongin-si, Gyeonggi-do, Korea
 Tel : +82-31-3236008,9
 Fax : +82-31-3236010
 www.ltalab.com

EUT/Model No.: DR901
 Temp/Humi: 23 °C / 55 % R.H.
 Test Mode : Operating mode_L
 Tested by: JUNG E H
 Power :

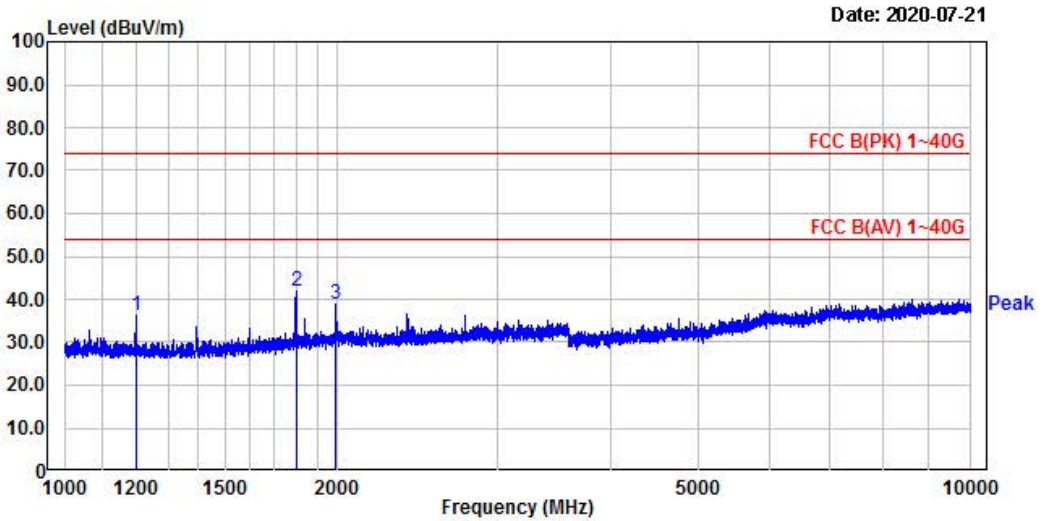

No.	Freq MHz	RD		C.F dB	Result		Limit		Margin		Height cm	Angle deg	Polarity
		PK dBµV	AV dBµV		PK dBµV	AV dBµV	PK dB	AV dB	PK dB	AV dB			
1.	1198.12	47.84	-----	-18.78	36.34	-----	74.88	-----	37.66	-----	188	336	vertical
2.	1798.35	49.84	-----	-7.27	41.77	-----	74.88	-----	32.23	-----	188	75	vertical
3.	1991.25	44.48	-----	-5.76	38.72	-----	74.88	-----	35.28	-----	188	238	vertical

Remarks: C.F (Correction Factor) = Antenna factor + Cable loss - Preamp gain



4, Songjuro 236Beon-gil, yanggi-myeon,
 Yongin-si, Gyeonggi-do, Korea
 Tel : +82-31-3236008,9
 Fax : +82-31-3236010
 www.ltalab.com

EUT/Model No.: DR901
 Temp/Humi: 23 °C / 55 % R.H.
 Test Mode : Operating mode_M
 Tested by: JUNG E H
 Power :

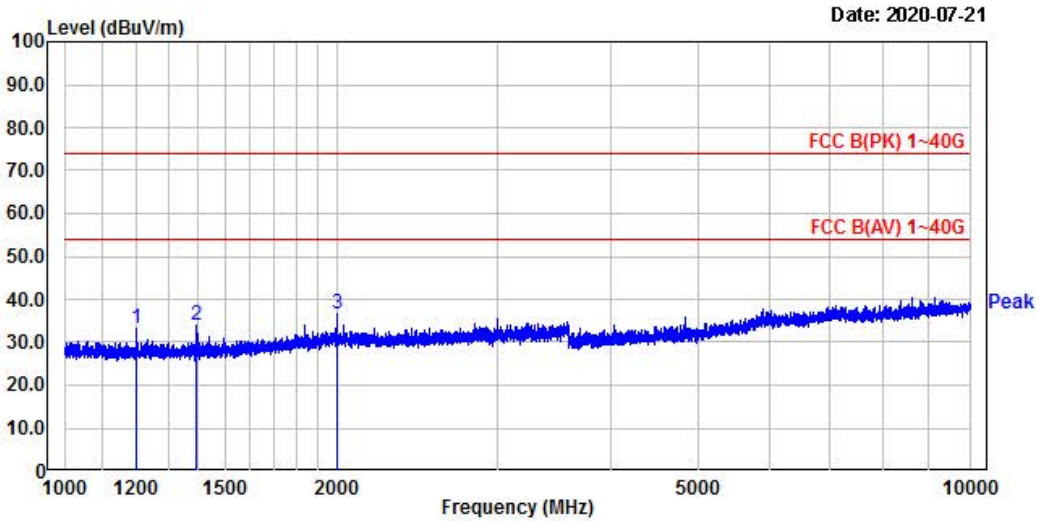

No.	Freq MHz	RD		C.F dB	Result		Limit		Margin		Height cm	Angle deg	Polarity
		PK dBµV	AV dBµV		PK dBµV	AV dBµV	PK dB	AV dB	PK dB	AV dB			
1.	1197.43	44.11	-----	-10.72	33.39	-----	74.00	-----	40.61	-----	100	46	horizontal
2.	1393.96	43.99	-----	-9.99	34.00	-----	74.00	-----	40.00	-----	100	175	horizontal
3.	1999.86	42.36	-----	-5.65	36.67	-----	74.00	-----	37.33	-----	100	186	horizontal

Remarks: C.F (Correction Factor) = Antenna factor + Cable loss - Preamp gain



4, Songjuro 236Beon-gil, yanggi-myeon,
 Yongin-si, Gyeonggi-do, Korea
 Tel : +82-31-3236008,9
 Fax : +82-31-3236010
 www.ltalab.com

EUT/Model No.: DR901 Temp/Humi: 23 °C / 55 % R.H.

 Test Mode : Operating mode_M Tested by: JUNG E H

 Power :

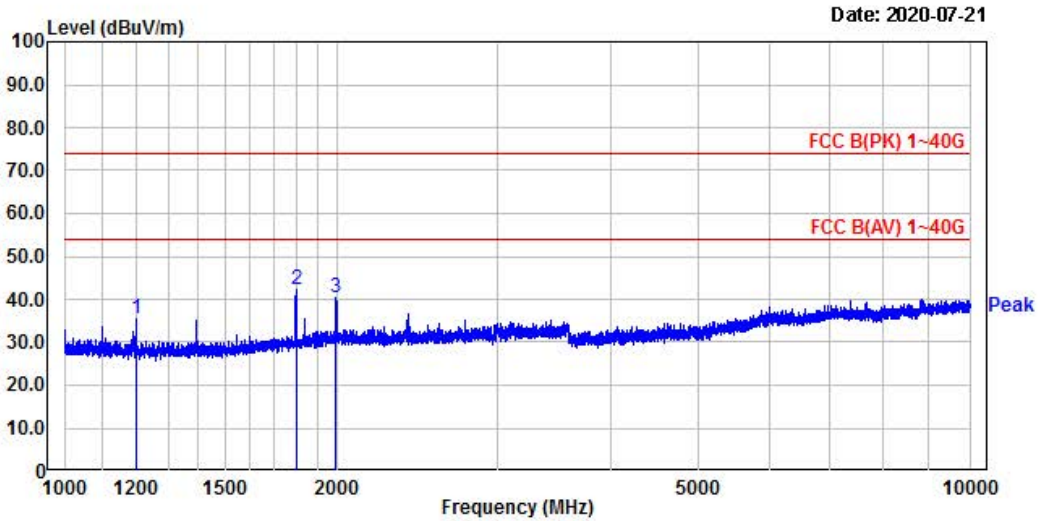

No.	Freq MHz	RD		C.F dB	Result		Limit		Margin		Height cm	Angle deg	Polarity
		PK dBμV	AV dBμV		PK dBμV	AV dBμV	PK dB	AV dB					
1.	1197.77	46.15	-----	-18.71	35.44	-----	74.88	-----	38.56	-----	188	286	vertical
2.	1798.35	49.44	-----	-7.27	42.17	-----	74.88	-----	31.83	-----	188	83	vertical
3.	1998.67	46.15	-----	-5.77	48.38	-----	74.88	-----	33.62	-----	188	62	vertical

Remarks: C.F (Correction Factor) = Antenna factor + Cable loss - Preamp gain



4, Songjuro 236Beon-gil, yanggi-myeon,
 Yongin-si, Gyeonggi-do, Korea
 Tel : +82-31-3236008,9
 Fax : +82-31-3236010
 www.ltalab.com

EUT/Model No.: DR901

Temp/Humi: 23 °C / 55 % R.H.

Test Mode : Operating mode_H

Tested by: JUNG E H

Power :

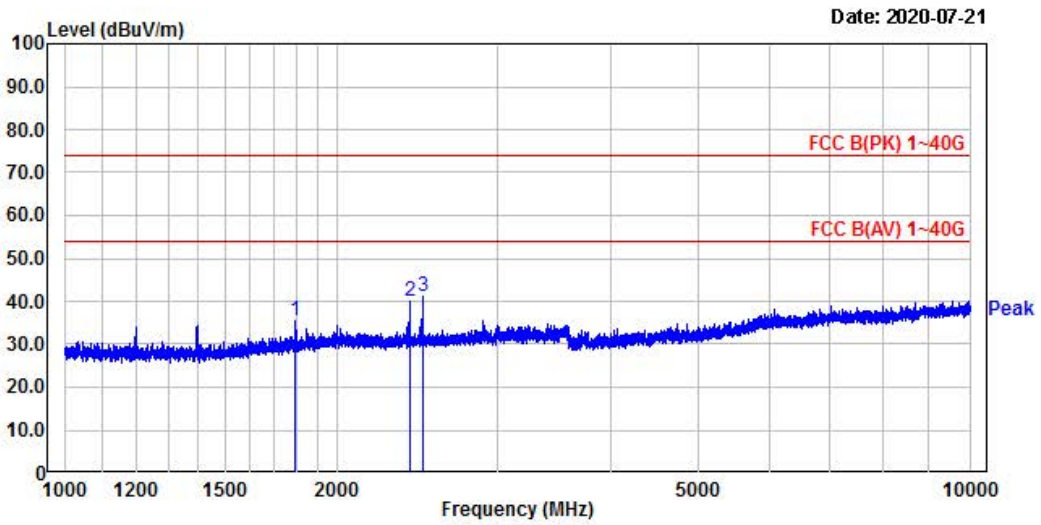

No.	Freq MHz	RD PK dBμV	RD AV dBμV	C.F dB	Result PK dBμV	Result AV dBμV	Limit PK dBμV	Limit AV dBμV	Margin PK dB	Margin AV dB	Height cm	Angle deg	Polarity
1.	1797.84	42.87	-----	-7.28	35.59	-----	74.00	-----	38.41	-----	100	13	horizontal
2.	2403.67	45.49	-----	-5.39	40.10	-----	74.00	-----	33.90	-----	100	335	horizontal
3.	2481.70	46.52	-----	-5.33	41.19	-----	74.00	-----	32.81	-----	100	95	horizontal

Remarks: C.F (Correction Factor) = Antenna factor + Cable loss - Preamp gain



4, Songjuro 236Beon-gil, yanggi-myeon,
 Yongin-si, Gyeonggi-do, Korea
 Tel : +82-31-3236008,9
 Fax : +82-31-3236010
 www.ltalab.com

EUT/Model No.: DR901
 Temp/Humi: 23 °C / 55 % R.H.
 Test Mode : Operating mode_H
 Tested by: JUNG E H
 Power :

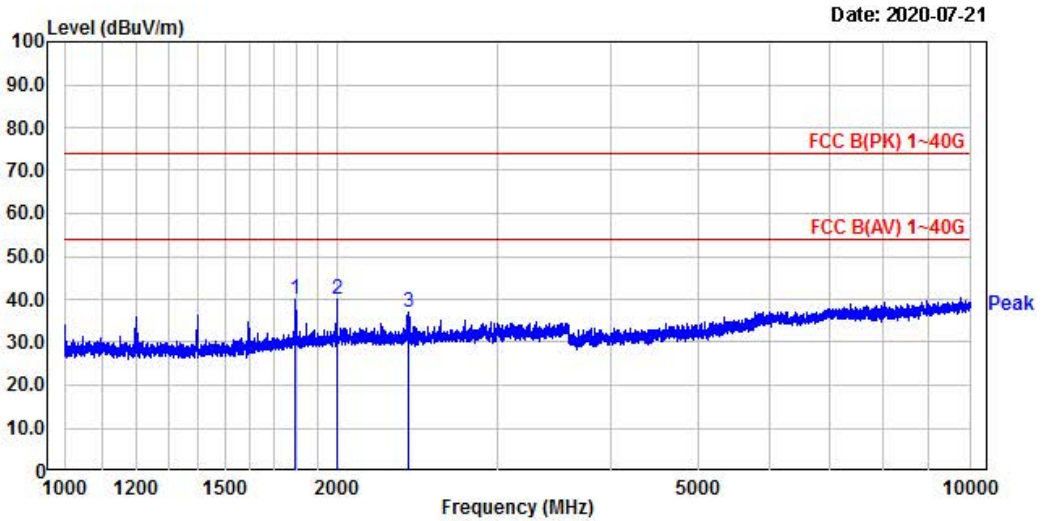

No.	Freq MHz	RD		C.F dB	Result		Limit		Margin		Height cm	Angle deg	Polarity
		PK dBµV	AV dBµV		PK dBµV	AV dBµV	PK dB	AV dB	PK dB	AV dB			
1.	1793.19	47.34	-----	-7.30	40.04	-----	74.00	-----	33.96	-----	100	181	vertical
2.	1996.41	45.77	-----	-5.71	40.06	-----	74.00	-----	33.94	-----	100	62	vertical
3.	2394.69	42.28	-----	-5.39	36.89	-----	74.00	-----	37.11	-----	100	100	vertical

Remarks: C.F (Correction Factor) = Antenna factor + Cable loss - Preamp gain

3.3.9 AC Conducted Emissions

Procedure:

The conducted emissions are measured in the shielded room with a spectrum analyzer in peak hold. While the measurement, EUT had its hopping function disabled at the middle channels in line with Section 15.31(m). Emissions closest to the limit are measured in the quasi-peak mode (QP) with the tuned receiver using a bandwidth of 9 kHz. The emissions are maximized further by cable manipulation and Exerciser operation. The highest emissions relative to the limit are listed.

Measurement Data: NA

Minimum Standard: FCC Part 15.207(a) / EN 55022

Class B

Frequency Range	quasi-peak	Average
0.15 ~ 0.5	66 to 56 *	56 to 46 *
0.5 ~ 5	56	46
5 ~ 30	60	50

* Decreases with the logarithm of the frequency

APPENDIX
TEST EQUIPMENT USED FOR TESTS

	Use	Description	Model No.	Serial No.	Manufacturer	Interval	Next Cal. Date
1		Signal Analyzer (9 kHz ~ 30 GHz)	FSV30	100757	R&S	1 year	2020-09-06
2		Signal Generator (~3.2 GHz)	8648C	3623A02597	HP	1 year	2021-03-20
3		SYNTHESIZED CW GENERATOR	83711B	US34490456	HP	1 year	2021-03-20
4		Attenuator (3 dB)	8491A	37822	HP	1 year	2020-09-06
5		Attenuator (10 dB)	8491A	63196	HP	1 year	2020-09-06
6	■	EMI Test Receiver (~40 GHz)	ESU	100092	R&S	1 year	2021-03-20
7	■	RF Amplifier (~40 GHz)	PAM-840A	461314	HP	1 year	2021-03-20
8	■	RF Amplifier (1~26.5 GHz)	8449B	3008A02126	HP	1 year	2021-03-20
9	■	Horn Antenna (1~18 GHz)	3115	00114105	ETS	2 year	2020-08-04
10	■	DRG Horn (Small)	3116B	81109	ETS-Lindgren	2 year	2022-03-18
11		DRG Horn (Small)	3116B	133350	ETS-Lindgren	2 year	2022-03-18
12	■	TRILOG Antenna	VULB 9160	9160-3237	SCHWARZBECK	2 year	2021-03-20
13		Temp.Humidity Data Logger	SK-L200TH II A	00801	SATO	1 year	2021-03-20
14		Splitter (SMA)	ZFSC-2-2500	SF617800326	Mini-Circuits	-	-
15	■	DC Power Supply	6674A	3637A01657	Agilent	-	-
17	■	Power Meter	EPM-441A	GB32481702	HP	1 year	2021-03-20
18	■	Power Sensor	8481A	3318A94972	HP	1 year	2020-09-06
19		Audio Analyzer	8903B	3729A18901	HP	1 year	2020-09-06
20		Modulation Analyzer	8901B	3749A05878	HP	1 year	2020-09-06
21		TEMP & HUMIDITY Chamber	YJ-500	LTAS06041	JinYoung Tech	1 year	2020-09-06
22		Stop Watch	HS-3	812Q08R	CASIO	2 year	2022-03-18
23		LISN	KNW-407	8-1430-1	Kyoritsu	1 year	2020-09-06
24		Two-Lime V-Network	ESH3-Z5	893045/017	R&S	1 year	2021-03-20
25		UNIVERSAL RADIO COMMUNICATION TESTER	CMU200	106243	R&S	1 year	2021-03-20
26		Highpass Filter	WHKX1.5/15G-10SS	74	Wainwright Instruments	1 year	2021-03-20
27		Highpass Filter	WHKX3.0/18G-10SS	118	Wainwright Instruments	1 year	2021-03-20
28		OSP120 BASE UNIT	OSP120	101230	R&S	1 year	2021-03-20
29	■	Signal Generator(100 kHz ~ 40 GHz)	SMB100A03	177621	R&S	1 year	2021-03-20
30	■	Signal Analyzer (10 Hz ~ 40 GHz)	FSV40	101367	R&S	1 year	2021-03-20
31	■	Active Loop Antenna	FMZB 1519	1519-031	SCHWARZBECK	2 year	2021-02-26