

# TEST REPORT

Report No: KST-FCR-140001

<b>Applicant</b>	Name	Bluebird Inc.
	Address	(Dogok-dong, SEI Tower 13,14) 39, Eonjuro30-gil, Gangnam-gu, Seoul, South Korea
<b>Manufacturer</b>	Name	Bluebird Inc.
	Address	(Dogok-dong, SEI Tower 13,14) 39, Eonjuro30-gil, Gangnam-gu, Seoul, South Korea
<b>Equipment</b>	Name	Handheld PDA
	Model No	BM180
	Brand	None
	FCC ID	SS4BM180
<b>Test Standard</b>	FCC CFR 47, Part 15. Subpart C-15.225	
<b>Test Date(s)</b>	2014. 02. 24 - 2014. 02. 24	
<b>Issue Date</b>	2014. 02. 25	
<b>Test Result</b>	Compliance	
<b>Note</b>	<ul style="list-style-type: none"> <li>- This equipment contained the certified module for WLAN 802.11abgn, Bluetooth 4.0.</li> <li>- Request for various model names derived from the name of the base model by manufacturer. derived additional model names: BP30</li> </ul>	

## Supplementary Information

The device bearing the brand name and FCC ID specified above has been shown to comply with the applicable technical standards as indicated in the measurement report and was tested in accordance with measurement procedures specified in ANSI C 63.10-2009.

We attest to the accuracy of data and all measurements reported herein were performed by KOSTEC Co., Ltd. and were made under Chief Engineer's supervision. We assume full responsibility for the completeness of these measurements and vouch for the qualifications of all persons taking them.

Tested by      Mi Young, Lee

Approved by      Gyeong Hyeon, Park

Signature



Signature



## Table of Contents

<b>1. GENERAL INFORMATION .....</b>	<b>3</b>
1.1 Test Facility .....	3
1.2 Location .....	3
<b>2. EQUIPMENT DESCRIPTION .....</b>	<b>4</b>
<b>3. SYSTEM CONFIGURATION FOR TEST .....</b>	<b>5</b>
3.1 Characteristics of equipment.....	5
3.2 Used peripherals list.....	5
3.3 Product Modification.....	5
3.4 Operating Mode.....	5
3.5 Test Setup of EUT .....	5
3.6 Used Test Equipment List.....	6
<b>4. SUMMARY TEST RESULTS .....</b>	<b>8</b>
<b>5. MEASUREMENT RESULTS .....</b>	<b>9</b>
5.1 Carrier Frequency tolerance.....	9
5.2 Field strength of radiated emissions .....	10
5.3 AC Power Conducted emissions .....	16
5.4 Antenna requirement .....	20
5.5 20 dB bandwidth measurement.....	21

## 1. GENERAL INFORMATION

### 1.1 Test Facility

#### Test laboratory and address

KOSTEC Co., Ltd.

180-254, Annyeong-dong, Hwaseong-si, Gyeonggi-do, South Korea

The open area field test site and conducted measurement facility are used for these testing. This site at was fully described in a reports submitted to the Federal Communications Commission (FCC).

The details of these reports have been found to be in complies with the requirements of Section 2.948 of the FCC Rules on November 14, 2002. The facility also complies with the radiated and conducted test site criteria set forth in ANSI C 63.10-2009.

The Federal Communications Commission (FCC) has the reports on file and KOSTEC Co., Ltd. is listed under FCC Registration No.525762. The test site has been approved by the FCC for public use and is List in the FCC Public Access Link CORES (Commission Registration System)

#### Registration information

KCC (Korea Communications Commission) Number : KR0041

KOLAS(Korea Laboratory Accreditation Scheme) Number : 232

FCC Registration Number(FRN) : 525762

VCCI Registration Number : R-1657 / C -1763

IC Registration Site Number : 8305A-1

### 1.2 Location



## 2. EQUIPMENT DESCRIPTION

The product specification described herein was declared by manufacturer. And refer to user's manual for the details.

1) Equipment Name	Handheld PDA
2) Model No	BM180
3) Brand Name	None
4) Usage	Handheld PDA
5) Serial Number	Proto type
6) ITU emission Code	Not required (because it is unlicensed devices)
7) Oscillation Type	X-tal
8) Data connection Type	RFID (Radio Frequency Identification)
9) Modulation type	ASK
10) Field Strength	25.72 dB $\mu$ V/m @ 30 meter**
11) Operated Frequency	13.561 Mhz
12) Channel Number	1 ea
13) Communication Type	Half duplex
15) Final Amplifier	U41
16) Operation temperature	- 20 °C ~ + 55 °C
17) Power Source	AC/DC adapter Input : AC 100-240 V, 0.3 A, 50 - 60 Hz Output : DC 5 V, 1.0 A Battery : DC 3.7 V
18) Antenna Description	Type : Internal PCB Antenna
19) FCC ID	SS4BM180

\*\* it is maximum peak power in band

### 3. SYSTEM CONFIGURATION FOR TEST

#### 3.1 Characteristics of equipment

The Equipment Under Test (EUT) contains the following capabilities:  
WLAN 802.11abgn, Bluetooth 4.0, RFID.

The test data contained in this report pertains only to the emissions due to the RFID transmitter of the EUT.

Manufacturer / Model	FCC ID	Description
Wistron Neweb Corporation / PW8Q7	NKR-PW8Q7A	802.11a/b/g/n 2.4GHz/5GHz + USB BT 4.0 card

#### 3.2 Used peripherals list

Description	Model No.	Serial No.	Manufacture	Remark
Battery	Egen	BAT-HM40_E-BM	None	
				-

#### 3.3 Product Modification

N/A

#### 3.4 Operating Mode

- \* Constantly transmitting with a modulated carrier at maximum power.
- \* Radiated emissions tests were performed with all unused ports terminated.

#### 3.5 Test Setup of EUT

The measurements were taken in continuous transmit / receive mode on condition that EUT was read a RFID card.

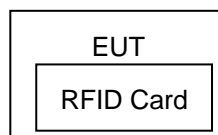

### 3.6 Used Test Equipment List

No.	Instrument	Model	S/N	Manufacturer	Due to cal date	Cal interval	used
1	T & H Chamber	EY-101	90E14260	TABAI ESPEC	2014.10.05	1 year	<input type="checkbox"/>
2	Constant switch Tester	DS-COT	None	Dong sung Ele.	N/A	N/A	<input type="checkbox"/>
3	Vibration Tester	70UA	L90016	IDEX Co.,Ltd	N/A	N/A	<input type="checkbox"/>
4	Vibration Meter	VM-6360	N225098	LANDTEK	2015.04.04	18 month	<input type="checkbox"/>
5	Falling Tester	SWD-8000	None	Sinwoo	N/A		<input type="checkbox"/>
6	Spectrum Analyzer	8563E	3846A10662	Agilent Technology	2015.02.07	1 year	<input type="checkbox"/>
7	Spectrum Analyzer	8593E	3710A02859	Agilent Technology	2015.02.07	1 year	<input type="checkbox"/>
8	Spectrum Analyzer	FSV30	20-353063	Rohde& Schwarz	2015.02.07	1 year	<input type="checkbox"/>
9	EMI Test Receiver	ESCI7	100823	Rohde& Schwarz	2015.02.05	1 year	<input checked="" type="checkbox"/>
10	EMI Test Receiver	ESI	834000/002	Rohde& Schwarz	2015.02.05	1 year	<input checked="" type="checkbox"/>
11	Vector Signal Analyzer	89441A	3416A02620	Agilent Technology	2015.02.07	1 year	<input type="checkbox"/>
12	Network Analyzer	8753ES	US39172348	AGILENT	2014.10.05	1 year	<input type="checkbox"/>
13	EPM Series Power meter	E4418B	GB39512547	Agilent Technology	2015.02.07	1 year	<input type="checkbox"/>
14	RF Power Sensor	E9300A	MY41496631	Agilent Technology	2015.02.07	1 year	<input type="checkbox"/>
15	Microwave Frequency Counter	5352B	2908A00480	Agilent Technology	2015.02.07	1 year	<input type="checkbox"/>
16	Modulation Analyzer	8901A	3538A07071	Agilent Technology	2015.02.07	1 year	<input type="checkbox"/>
17	Audio Analyzer	8903B	3514A16919	Agilent Technology	2015.02.07	1 year	<input type="checkbox"/>
18	Audio Telephone Analyzer	DD-5601CID	520010281	CREDIX	2015.02.07	1 year	<input type="checkbox"/>
19	Digital storage Oscilloscope	TDS3052	B015962	Tektronix	2014.10.05	1 year	<input type="checkbox"/>
20	ESG-D Series Signal Generator	E4436B	US39260458	Agilent Technology	2015.02.07	1 year	<input checked="" type="checkbox"/>
21	ESG Vector Signal Generator	E4438C	MY42083133	Agilent Technology	2014.10.05	1 year	<input type="checkbox"/>
22	Vector Signal Generator	SMBV100A	257557	Rohde & Schwarz	2015.01.21	1 year	<input type="checkbox"/>
23	Tracking Source	85645A	070521-A1	Agilent Technology	2015.02.07	1 year	<input type="checkbox"/>
24	Signal Generator	SML03	100692	Rohde& Schwarz	2015.02.07	1 year	<input type="checkbox"/>
25	Arbitrary waveform Generator	AFG3021	C011995	Tektronix	2015.02.07	1 year	<input type="checkbox"/>
26	SLIDAC	None	0207-4	Myoung sung Ele.	2015.02.07	1 year	<input type="checkbox"/>
27	DC Power supply	DRP-5030	9028029	Digital Electronic Co.,Ltd	2015.02.07	1 year	<input type="checkbox"/>
28	DC Power supply	6038A	3440A12674	Agilent Technology	2015.02.07	1 year	<input type="checkbox"/>
29	DC Power supply	E3610A	KR24104505	Agilent Technology	2015.02.07	1 year	<input checked="" type="checkbox"/>
30	DC Power supply	UP-3005T	68	Unicon Co.,Ltd	2015.02.07	1 year	<input type="checkbox"/>
31	DC Power Supply	SM 3004-D	114701000117	DELTAELEKTRONIKA	2015.02.07	1 year	<input type="checkbox"/>
32	Dummy Load	8173	3780	Bird Electronic Co., Corp	2015.02.07	1 year	<input type="checkbox"/>
33	Attenuator	50FH-030-500	140410 9433	JEW Industries Inc.	2015.02.07	1 year	<input type="checkbox"/>
34	Attenuator	765-20	9703	Narda	2014.10.05	1 year	<input type="checkbox"/>
35	Attenuator	8498A	3318A09485	HP	2015.02.07	1 year	<input type="checkbox"/>
36	Step Attenuator	8494B	3308A32809	HP	2015.02.07	1 year	<input type="checkbox"/>
37	Step Attenuator	8495D	3308A01464	HP	2015.02.07	1 year	<input type="checkbox"/>
38	Power divider	11636B	51212	HP	2014.10.05	1 year	<input type="checkbox"/>
39	3Way Power divider	KPDSU3W	00070365	KMW	2015.02.07	1 year	<input type="checkbox"/>
40	Band rejection filter	WTR-BRF2442-84NN	09020001	WAVE TECH Co.,LTD	2015.02.07	1 year	<input type="checkbox"/>
41	White noise audio filter	ST31EQ	101902	SoundTech	2014.10.05	1 year	<input type="checkbox"/>
42	Dual directional coupler	778D	17693	HEWLETT PACKARD	2015.02.07	1 year	<input type="checkbox"/>
43	Dual directional coupler	772D	2839A00924	HEWLETT PACKARD	2015.02.07	1 year	<input type="checkbox"/>
44	Band rejection filter	3TNF-0006	26	DOVER Tech	2015.02.07	1 year	<input type="checkbox"/>
45	Band rejection filter	3TNF-0008	317	DOVER Tech	2015.02.07	1 year	<input type="checkbox"/>
46	Band rejection filter	3TNF-0007	311	DOVER Tech	2015.02.07	1 year	<input type="checkbox"/>
47	Highpass Filter	WHJS1100-10EF	1	WAINWRIGHT	2015.02.07	1 year	<input type="checkbox"/>
48	Highpass Filter	WHJS3000-10EF	1	WAINWRIGHT	2015.02.07	1 year	<input type="checkbox"/>
49	Radio Communication Alalyzer	MT8815A	6200429622	ANRITSU	2015.02.07	1 year	<input type="checkbox"/>
50	CDMA Mobile Station Test Set	E8285A	US40081298	AGILENT	2015.02.07	1 year	<input type="checkbox"/>
51	WideBand Radio Communication Tester	CMW500	127302	Rohde & Schwarz	2014.02.18	1 year	<input type="checkbox"/>

No.	Instrument	Model	S/N	Manufacturer	Due to cal date	Cal interval	used
52	RF Up/Down Converter	DCP-1780	980901003	CREDIX	2014.02.28	1 year	<input type="checkbox"/>
53	DECT Test set	8923B	3829U00364	HP	2014.02.28	1 year	<input type="checkbox"/>
54	DECT Test set	CMD60	840677/005	Rohde& Schwarz	2014.12.04	1 year	<input type="checkbox"/>
55	Loop Antenna	6502	9203-0493	EMCO	2015.05.31	2 year	<input checked="" type="checkbox"/>
56	Dipole Antenna	HZ-12	100005	Rohde & Schwarz	2014.04.19	2 year	<input type="checkbox"/>
57	Dipole Antenna	HZ-13	100007	Rohde & Schwarz	2014.04.19	2 year	<input type="checkbox"/>
58	BiconiLog Antenna	HL562	100075	Rohde & Schwarz	2015.04.10	2 year	<input type="checkbox"/>
59	BiconiLog Antenna	HL562	100076	Rohde & Schwarz	2014.12.10	2 year	<input checked="" type="checkbox"/>
60	Horn Antenna	3115	9605-4834	EMCO	2014.07.04	2 year	<input checked="" type="checkbox"/>
61	Horn Antenna	3115	2996	EMCO	2014.05.15	2 year	<input type="checkbox"/>
62	Signal Generator	SMT-06	100552	Rohde & Schwarz	2015.02.07	1 year	<input type="checkbox"/>
63	HYGRO-Thermograph	NSII-Q	1611545	SATO	2014.10.05	1 year	<input type="checkbox"/>
64	Barometer	7612	81134	SATO	2016.01.20	2 year	<input type="checkbox"/>
65	Multi meter	DM-313	S60901832	LG Precision Co.,Ltd	2015.02.07	1 year	<input type="checkbox"/>
66	Antenna Mast(OSA)	AT14	None	Daeil EMC	N/A	N/A	<input type="checkbox"/>
67	Turn table(OSA)	None	None	Daeil EMC	N/A	N/A	<input type="checkbox"/>
68	RF Amplifier(OSA)	8447D	2944A07881	AGILENT	2015.02.04	1 year	<input type="checkbox"/>
69	Antenna Master(3)	AT13	None	AUDIX	N/A	N/A	<input checked="" type="checkbox"/>
70	Turn Table(3)	None	None	AUDIX	N/A	N/A	<input checked="" type="checkbox"/>
71	PREAMPLIFIER(3)	8449B	3008A02577	Agilent	2015.02.05	1 year	<input checked="" type="checkbox"/>
72	Antenna Master(10)	MA4000-EP	None	inno systems GmbH	N/A	N/A	<input checked="" type="checkbox"/>
73	Turn Table(10)	None	None	inno systems GmbH	N/A	N/A	<input checked="" type="checkbox"/>
74	AMPLIFIER(10)	TK-PA6S	120009	TESTEK	2015.02.05	1 year	<input type="checkbox"/>
75	Vernier Calipers	None	8280373	Mitutoyo	2014.10.05	1 year	<input type="checkbox"/>

## 4. SUMMARY TEST RESULTS

Description of Test	FCC Rule	Reference Clause	Used	Test Result
Carrier frequency tolerance	15.225(e)	Clause 5.1	<input checked="" type="checkbox"/>	Compliance
Field strength of radiated emission	15.225(a) ~ (d)	Clause 5.2	<input checked="" type="checkbox"/>	Compliance
AC Conducted emission	15.207	Clause 5.3	<input checked="" type="checkbox"/>	Compliance
Antenna requirement	15.203, 15.247	Clause 5.4	<input checked="" type="checkbox"/>	Compliance
20 dB bandwidth measurement	2.1049	Clause 5.4	<input checked="" type="checkbox"/>	Compliance
<p>Compliance/pass : The EUT complies with the essential requirements in the standard.            Not Compliance : The EUT does not comply with the essential requirements in the standard.            N/A : The test was not applicable in the standard.</p>				



## 5. MEASUREMENT RESULTS

### 5.1 Carrier Frequency tolerance

#### 5.1.1 Standard Applicable [FCC §15.225(e)]

The frequency tolerance of the carrier signal shall be maintained within +/- 0.01% of the operating frequency Over a temperature variation of - 20 degrees to + 50 degrees C at normal supply voltage, and for a variation In the primary supply from 85 % to 115 % of the rated supply voltage at a temperature of 20 degrees C. For battery operated equipment, the equipment tests shall be performed using a new battery.

#### 5.1.2 Test Environment conditions

- Ambient temperature : 21 °C,
- Relative Humidity : ( 50 - 53 ) % R.H.

#### 5.1.3 Measurement Procedure

Before measurements are made the equipment shall have reached thermal balance in the Test chamber period. and then it is normal operating for about 15 minutes after thermal balance has been reached. For tests at the extreme temperature, the equipment shall be left in the test chamber until thermal balance is attained, then the standby or receive condition for a period of a few minute after which the equipment shall meet the specified requirements. The test data sheet recorded measured value by frequency counter.

#### 5.1.4 Test setup

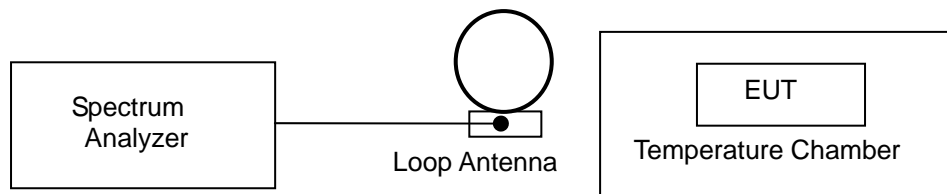

#### 5.1.5 Measurement Result

Frequency (13.561 MHz)		Measured frequency [Hz]	Frequency Tolerance		
			%	Hz	
T <sub>NOM</sub>	+ 21 °C	New battery	13,561,090	0.000664	90
T <sub>MIN</sub>	- 20 °C	New battery	13,561,085	0.000627	85
T <sub>MAX</sub>	+ 55 °C	New battery	13,561,093	0.000686	93
LIMIT		Within in (±) 0.01 % or (±) 1 356 Hz			
Max. Tolerance		0.000686 %, +93 Hz			
Result		Compliance			

## 5.2 Field strength of radiated emissions

### 5.2.1 Standard Applicable [FCC §15.225 (a) ~ (d)]

(a) The Field strength of any emissions within the band 13.553-13.567 MHz shall not exceed 15,848  $\mu\text{V}/\text{m}$  at 30 meter

(b) Within the bands 13.410-13.553 MHz and 13.567-13.710 MHz, the field strength of any emissions shall not exceed 334 micro volts/meter at 30 meter

(c) Within the bands 13.110-13.410 MHz and 13.710-14.010 MHz, the field strength of any emissions shall not exceed 106 micro volts/meter at 30 meter

(d) The Field strength of any emissions appearing outside of the 13.110-14.010 MHz band shall not exceed The general radiated emission limits in §15.209

Above required standard (a ~ c) and (d) is brief describe table as follows

#### § 15.225 [(a) ~ (c)] : Limit for in-band field strength

Frequency Band (MHz)	Limit		Measurement distance (meter)
	( $\mu\text{V}/\text{m}$ )	( $\text{dB}\mu\text{V}/\text{m}$ )	
13.553 – 13.567	15,848	84.00	30
13.410 – 13.553 13.567 – 13.710	334	50.47	30
13.110 – 13.410 13.710 – 14.010	106	40.50	30

#### §15.209. limits for radiated emissions measurements

Frequency Band	Limit [ $\mu\text{V}/\text{m}$ ]	Limit [ $\text{dB}\mu\text{V}/\text{m}$ ]	Measurement distance (meter)	Detector
0.009 – 0.490	2 400/F (kHz)	-	300	
0.490 – 1.705	2 4000/F (kHz)	-	30	
1.705 – 30.0	30	29.54	30	Quasi peak
30 - 88	100 **	40.0	3	Quasi peak
88 - 216	150 **	43.5	3	Quasi peak
216 - 960	200 **	46.0	3	Quasi peak
Above 960	500	54.0	3	Peak & Average

\*\* fundamental emissions from intentional radiators operation under this Section shall not be located in the frequency bands 54-72 MHz, 76-88 MHz, 174-216 MHz, or 470-806 MHz. However, operation within these Frequency bands is permitted under other sections of this Part Section 15.231 and 15.241

§15.205. [Table 1] : Restrict Band of Operation

Only spurious emissions are permitted in any of the frequency bands listed below ;

[MHz]	[MHz]	[MHz]	[GHz]
0.090 - 0.110	16.42 - 16.423	399.9 - 410	4.5 - 5.15
0.495 - 0.505**	16.69475 - 16.69525	608 - 614	5.35 - 5.46
2.1735 - 2.1905	16.80425 - 16.80475	960 - 1240	7.25 - 7.75
4.125 - 4.128	25.5 - 25.67	1300 - 1427	8.025 - 8.
4.17725 - 4.17775	37.5 - 38.25	1435 - 1626.5	9.0 - 9.2
4.20725 - 4.20775	73 - 74.6	1645.5 - 1646.5	9.3 - 9.5
6.215 - 6.218	74.8 - 75.2	1660 - 1710	10.6 - 12.7
6.26775 - 6.26825	108 - 121.94	1718.8 - 1722.2	13.25 - 13.
6.31175 - 6.31225	123 - 138	2200 - 2300	14.47 - 14.5
8.291 - 8.294	149.9 - 150.05	2310 - 2390	15.35 - 16.2
8.362 - 8.366	156.52475 - 156.52525	2483.5 - 2500	17.7 - 21.4
8.37625 - 8.38675	156.7 - 156.9	2690 - 2900	22.01 - 23.12
8.41425 - 8.41475	162.0125 - 167.17	3260 - 3267	23.6 - 24.0
12.29 - 12.293	167.72 - 173.2	3332 - 3339	31.2 - 31.8
12.51975 - 12.52025	240 - 285	3345.8 - 3358	36.43 - 36.5
12.57675 - 12.57725	322 - 335.4	3600 - 4400	Above 38.6

\*\* Until February 1, 1999, this restricted band shall be 0.490-0.510

### 5.2.2 Test Environment conditions

- Ambient temperature : 21 °C,
- Relative Humidity : ( 52 - 55 ) % R.H.

### 5.2.3 Measurement Procedure

The measurements procedure of the transmitter radiated E-field is as following describe method.

The test is performed in a Shield chamber to determine the accurate frequencies, after maximum emissions level will be checked on a test chamber and measuring distance is 3 m from EUT to test antenna.

(The chamber is ensured that comply with at least 6 dB above the ambient noise level)

- ① The EUT was powered ON with continuously operating mode and placed on a 0.8 meter high non-conductive table on the reference ground plane.
- ② The test antenna was used on Horn antenna for above 1 GHz, and if the below 1 GHz, broad-band antenna and Loop antenna were used for below 30 MHz and it's antenna positioned in both the horizontal and vertical plane was location at EUT during the test for maximized the emission measurement.
- ③ The output of the test antenna will be connected to a measuring receiver, and it is set to tuned over the frequency range according to required standard
- ④ The measuring detector type of the measurement receiver is based on average value of measurement instrumentation employing a CISPR Quasi Peak detector according to required standard and for above 1 GHz, set the spectrum analyzer on a average and peak detector for the provisions in §15.35 and investigated frequency range is set the spectrum analyzer according to §15.33.
- ⑤ The fundamental frequency at which a relevant radiated signal component is detected, the test antenna

will be raised and lowered through the specified range of heights in horizontal and vertical polarized orientation, until an maximum signal level is detected on the measuring receiver.

- ⑥ The transmitter is position x, y, z axis on rotating through 360 degrees, until the maximum signal level is detected by the measuring receiver.
  - ⑦ The receiver is scanned from requested measuring frequency band and then the maximum meter reading is recorded. The radiated emissions were measured with required standard.
- The measurement results are obtained as described below:  
Result(dB  $\mu$ V/m) = Reading(dB  $\mu$ V) + Antenna factor(dB/m) + CL(dB) + other applicable factor (dB)
  - According to §15.33 (a)(1), Frequency range of radiated measurement is performed the tenth harmonic.
- ※ if necessary, additionally receiver is adopted high-pass filter and preamp because lower radiated signal
- ※ The transmitter radiated spectrum was investigated from 9 kHz to 10<sup>th</sup> harmonic and the worst-case emissions were reported.

#### 5.2.4 Measurement Uncertainty

All measurements involve certain levels of uncertainties. The factors contributing to uncertainties are test receiver, Cable loss, Antenna factor calibration, antenna directivity, antenna factor variation with height, antenna phase center variation, Antenna frequency interpolation, measurement distance variation, Site imperfection, mismatch, and system repeatability based on NIS 80,81.

Radiated Emission measurement: 30 - 1000 MHz: 4.4 dB (CL: Approx 95 %, k=2)  
Above 1 GHz: 4.88 dB (CL: Approx 95 %, k=2)

## 5.2.5 Test Configuration

### Radiated emission setup, Below 30 MHz

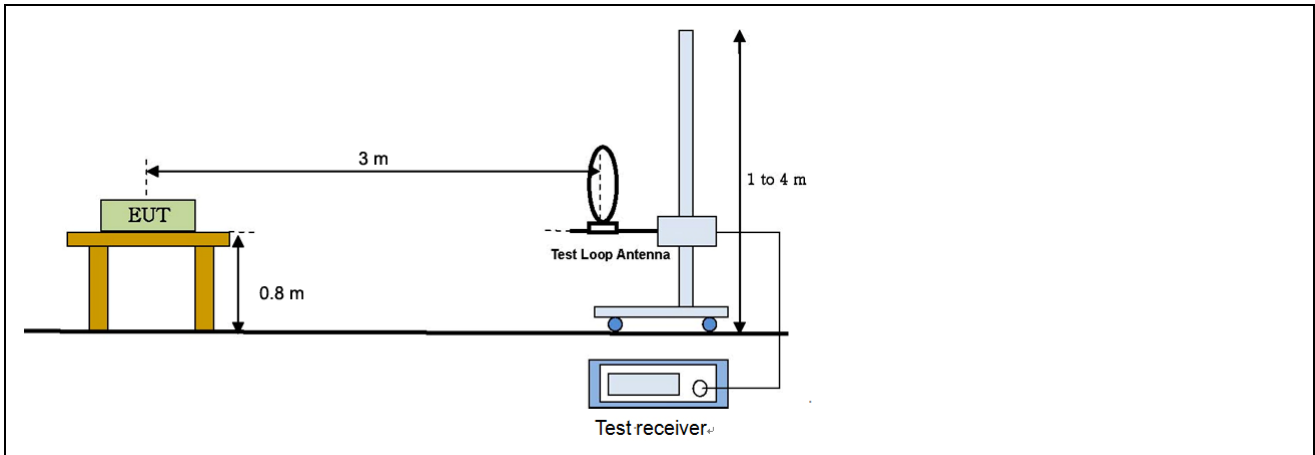

### Radiated emission setup, Below 1 000 MHz

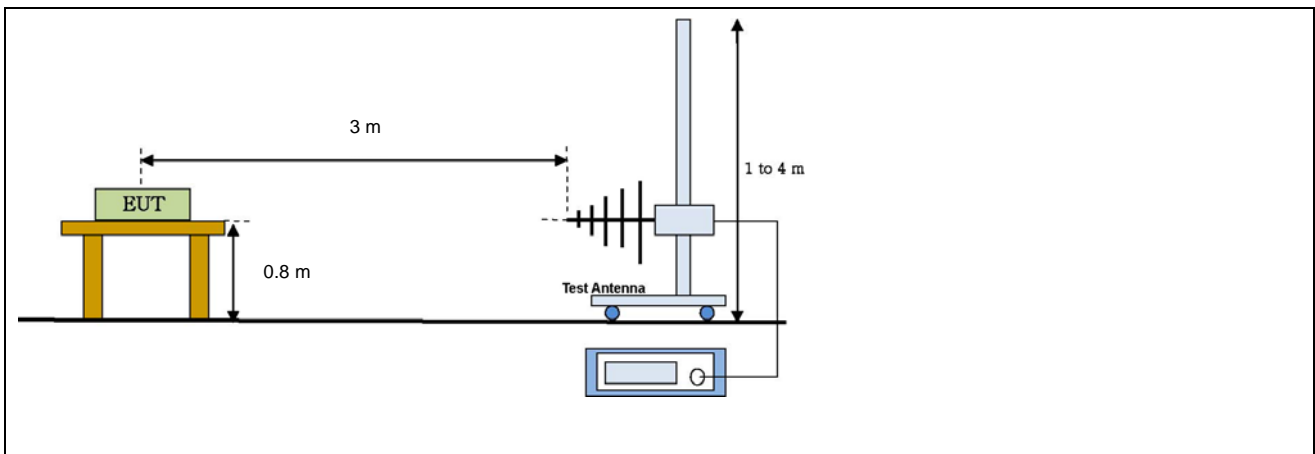

### Radiated emission setup, Above 1 GHz

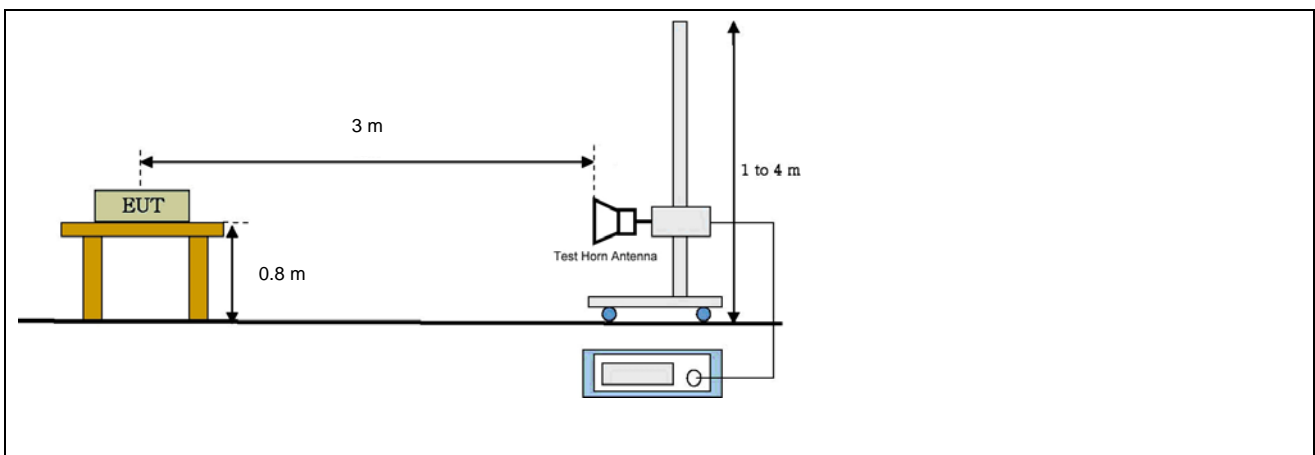

## 5.2.6 Measurement Result

### ■ IN-BAND

Freq. (MHz)	Reading (dB $\mu$ V/m)	Table (Deg)	Pstn (axis)	Antenna			CL (dB)	Pre AMP (dB)	Distn factor (dB)	Meas Result (dB $\mu$ V/m)	Limit (dB $\mu$ V/m)	Mgn (dB)	Result
				Height (m)	Pol. (H/V)	Fctr. (dB/m)							
13.56*	35.40	120	X	1.0	-	8.84	0.56	-	-19.08	25.72	84.00	58.28	Compliance
13.35	14.16	130	X	1.0	-	8.84	0.56	-	-19.08	4.48	40.50	36.02	Compliance

\*It is fundamental frequency

Note1. above measured frequency have been done at 10 m distance and corrected according to required FCC 15.209. e)

$\therefore$  Extrapolation distance factor :  $40\log(10/30) = -19.08$  dB If Measurement distance is 10 m and Mandatory requirement distance is 30 m at 30 MHz or less, extrapolation distance factor(dB) is  $40 / \text{decade} = 40 \log_{10}^{(MRD/MD)}$

MRD is Mandatory requirement distance and MD is Measured distance

Note2. above measured frequencies is apply required standard FCC Part 15.225

Note3. All measurements were performed using a loop antenna. The antenna was positioned in three orthogonal positions (X front, Y side, Z top) and the position with the highest emission level was recorded.

Note4. All measurements were recorded using a quasi-peak detector.

Freq.(MHz) : Measurement frequency, Reading(dB $\mu$ V/m) : Indicated value for test receiver,

Table (Deg) : Directional degree of Turn table, Pstn(axis) : Location axis of EUT

Antenna (Height, Pol, Fctr) : Antenna Height, Polarization and Factor

Cbl(dB) : Cable loss, Distn factor(dB) : distance correction factor [40 dB/decade as per § 15.31f (2)]

Meas Result (dB $\mu$ V/m) : Reading(dB $\mu$ V/m)+ Antenna factor.(dB/m) + CL(dB) + Distn factor(dB)

Limit(dB $\mu$ V/m): Limit value specified with FCC Rule, Mgn(dB) : FCC Limit (dB $\mu$ V/m) – Meas Result(dB $\mu$ V/m)

### ■ OUT- BAND

Freq. (MHz)	Reading (dB $\mu$ V/m)	Table (Deg)	Antenna			CL (dB)	Pre AMP (dB)	Meas Result (dB $\mu$ V/m)	Limit (dB $\mu$ V/m)	Mgn (dB)	Result
			Height (m)	Pol. (H/V)	Fctr. (dB/m)						
--- Nil emissions ---											Compliance

Freq.(MHz) : Measurement frequency, Reading(dB $\mu$ V/m) : Indicated value for test receiver,

Table (Deg) : Directional degree of Turn table,

Antenna (Height, Pol, Fctr) : Antenna Height, Polarization and Factor

Cbl(dB) : Cable loss, Pre AMP(dB) : Preamplifier gain(dB)

Meas Result (dB $\mu$ V/m) : Reading(dB $\mu$ V/m)+ Antenna factor.(dB/m) + CL(dB) - Pre AMP(dB)

Limit(dB $\mu$ V/m): Limit value specified with FCC Rule, Mgn(dB) : FCC Limit (dB $\mu$ V/m) – Meas Result(dB $\mu$ V/m)

### 5.2.7 Test plot

Fundamental frequency level &  $\leq 30$  MHz spectrum mask

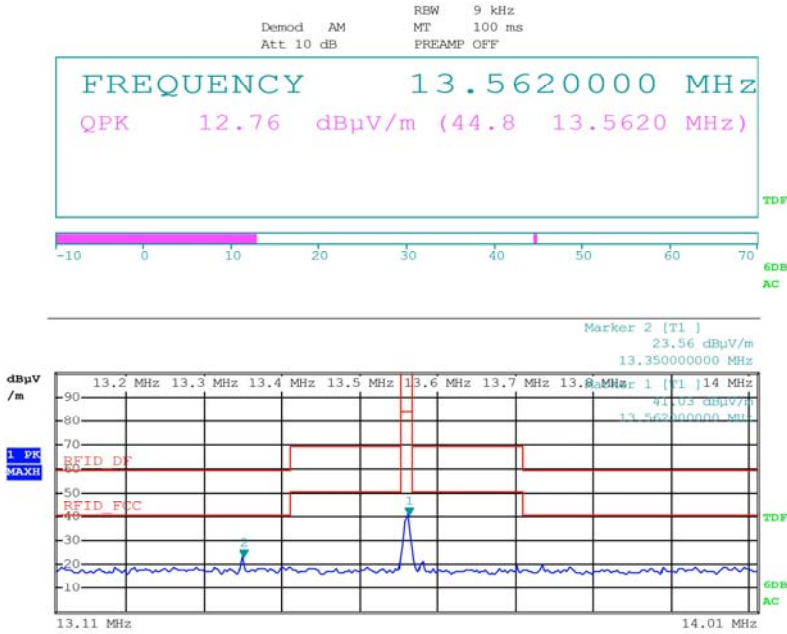

## 5.3 AC Power Conducted emissions

### 5.3.1 Standard Applicable [ FCC §15.207(a) ]

For intentional radiator that is designed to be connected to the public utility(AC)power line, the radio frequency. Voltage that is conducted back onto the AC power line on any frequencies hopping mode within the band 150 kHz to 30 MHz shall not exceed the limits in the following table, as measured using a 50 uH/50 ohms line Impedance stabilization network(LISN). Compliance with the provisions of this paragraph shall be based on the measurement of the radio frequency voltage between each power line and ground at the power terminal. The lower limit applies at the boundary between the frequency ranges.

§15.207 limits for AC line conducted emissions;

Frequency of Emission(MHz)	Conducted Limit (dB $\mu$ V)	
	Quasi-peak	Average
0.15 ~ 0.5	66 to 56 *	56 to 46 *
0.5 ~ 5	56	46
5 ~ 30	60	50

\* Decreases with the logarithm of the frequency

### 5.3.2 Test Environment conditions

- Ambient temperature : 21 °C,
- Relative Humidity : ( 50 -53 ) % R.H.

### 5.3.3 Measurement Procedure

The measurements were performed in a shielded room. EUT was placed on a non-metallic table Height of 0.4 m above the reference ground plane. They were folded back and forth forming a bundle 30 cm to 40 cm long and were hanged at a 40 cm height to the ground plane. Each EUT power lead, except ground (safety) lead, was individually connected through a LISN to Input power source. Both lines of power cord, live and neutral, were measured.

### 5.3.4 Used equipment

Equipment	Model No.	Serial No.	Manufacturer	Next cal date	Used
Test receiver	ESCS30	100111	Rohde & Schwarz	2015.02.05	●
LISN	ESH2-Z5	100044	R&S	2015.02.05	-
	ESH3-Z5	100147	R&S	2015.02.05	●

Measurement uncertainty : Conducted Emission measurement: 3.5 dB (CL: Approx 95%, k=2)



### 5.3.5 Measurement Result

**< Class B >**

Freq. [MHz]	Factor [dB]		POL	QP			CISPR AV		
	LISN	CABLE		Limit [dB $\mu$ V]	Reading [dB $\mu$ V]	Result [dB $\mu$ V]	Limit [dB $\mu$ V]	Reading [dB $\mu$ V]	Result [dB $\mu$ V]
0.158	0.08	0.1	N	65.58	44.73	44.88	55.58	37.13	37.28
0.201	0.08	0.1	N	63.58	41.33	41.47	53.58	35.14	35.28
0.240	0.08	0.1	N	62.10	39.03	39.17	52.10	33.64	33.78
0.283	0.08	0.1	N	60.73	35.47	35.62	50.73	30.83	30.98
0.322	0.06	0.1	L	59.66	35.75	35.88	49.66	35.63	35.76
0.400	0.08	0.1	L	57.85	33.95	34.10	47.85	33.83	33.98
0.521	0.09	0.1	N	56.00	30.09	30.26	46.00	29.82	29.99
0.560	0.10	0.1	L	56.00	28.39	28.57	46.00	28.22	28.40
1.244	0.12	0.1	L	56.00	23.75	23.98	46.00	20.59	20.82
1.404	0.11	0.1	N	56.00	24.78	25.02	46.00	22.27	22.51
1.810	0.12	0.2	N	56.00	22.97	23.27	46.00	18.32	18.62
2.162	0.14	0.2	N	56.00	22.95	23.29	46.00	18.80	19.14
5.580	0.27	0.3	N	60.00	19.74	20.27	50.00	15.34	15.87
12.791	0.63	0.4	N	60.00	27.35	28.37	50.00	17.51	18.53
15.822	0.51	0.5	L	60.00	29.40	30.36	50.00	20.05	21.01
16.240	0.82	0.5	N	60.00	36.61	37.89	50.00	25.04	26.32
18.818	0.57	0.5	L	60.00	22.38	23.45	50.00	12.10	13.17
18.912	0.94	0.5	N	60.00	39.88	41.32	50.00	25.20	26.64

- \* LISN: LISN insertion Loss, Cable: Cable Loss
- \* Reading: test receiver reading value
- \* Result = LISN + Cable + Reading

### 5.3.6 Test Plot

Line. Live

Kostec Co., Ltd.

10 Feb 2014 21:04

#### Conducted Emission

EUT: BM180  
Manuf: Bluebird Inc.  
Op Cond: AC 120 V / 60 Hz  
Operator: S.S.Kim  
Test Spec: FCC Part15 SubpartB  
Comment: Live

Result File: bule\_l.dat : New Measurement

#### Scan Settings (1 Range)

Frequencies				Receiver Settings				
Start	Stop	Step	IF BW	Detector	M-Time	Atten	Preamp	OpRge
150kHz	30MHz	3.9063kHz	9kHz	PK+AV	10msec	15 dB	OFF	60dB

Transducer	No.	Start	Stop	Name
	12	9kHz	30MHz	CNEFactor

Final Measurement: Detectors: X QP / + AV  
Meas Time: 1sec  
Subranges: 25  
Acc Margin: 50 dB

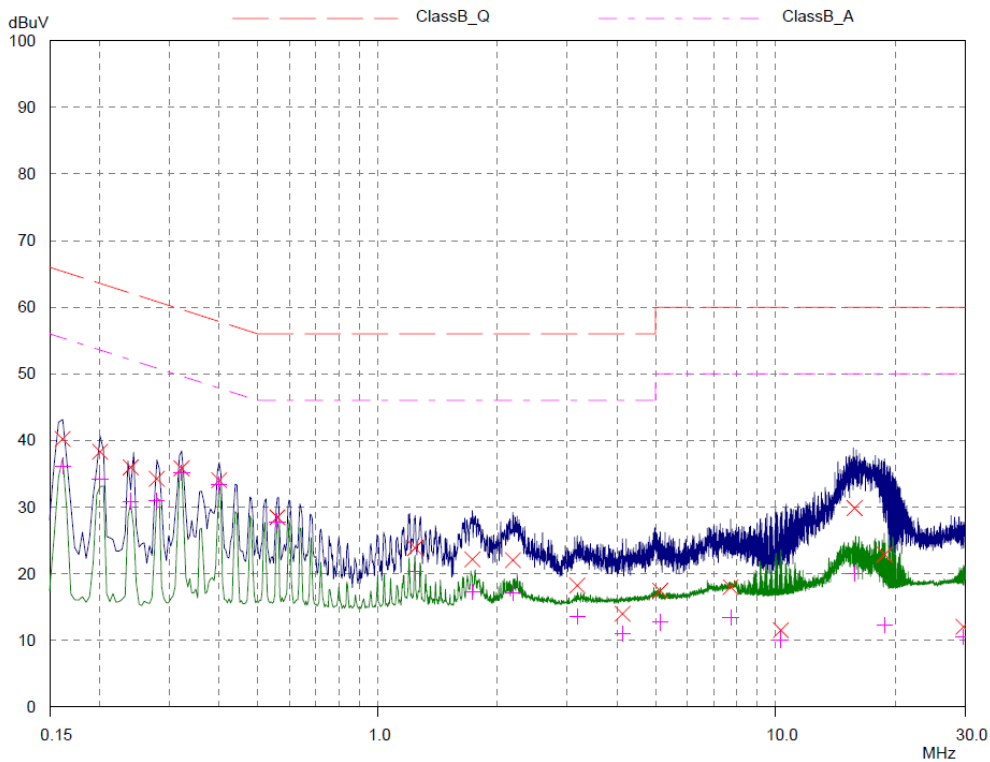

## Line. Neutral

Kostec Co., Ltd.

10 Feb 2014 20:57

### Conducted Emission

EUT: BM180  
 Manuf: Bluebird Inc.  
 Op Cond: AC 120 V / 60 Hz  
 Operator: S.S.Kim  
 Test Spec: FCC Part15 SubpartB  
 Comment: Neutral

Result File: bule\_n.dat : New Measurement

#### Scan Settings (1 Range)

Frequencies			Receiver Settings					
Start	Stop	Step	IF BW	Detector	M-Time	Atten	Preamp	OpRge
150kHz	30MHz	3.9063kHz	9kHz	PK+AV	10msec	15 dB	OFF	60dB

Transducer	No.	Start	Stop	Name
	12	9kHz	30MHz	CNEFactor

Final Measurement: Detectors: X QP / + AV  
 Meas Time: 1sec  
 Subranges: 25  
 Acc Margin: 50 dB

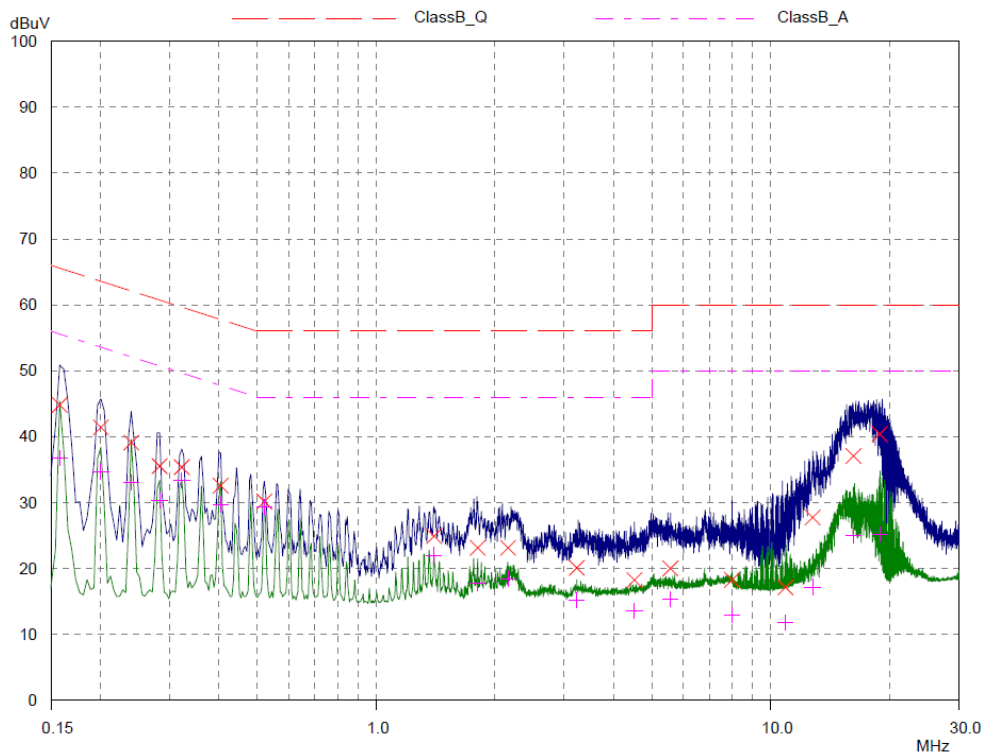

## 5.4 Antenna requirement

### 5.4.1 Standard applicable [FCC §15.203]

For intentional device, according to §15.203, an intentional radiator shall be designed to ensure that no antenna other than furnished by responsible party shall be used with the device.

The use of a permanently attached antenna or of an antenna that user a unique coupling to the intentional radiator shall be considered sufficient to comply with the provisions of this section.

The manufacturer may design the unit So that broken antenna can be replaced by the user, but the Use of a standard antenna jack or electrical connector is prohibited.

The NFC antenna is located on one specific battery cover of EUT and uses a unique coupling to the intentional radiator. So The Handheld PDA FCC ID: SS4BM180 Unit complies with the requirement of §15.203.

## 5.5 20 dB bandwidth measurement

### 5.5.1 Standard applicable [FCC §2.1049]

The 20 dB bandwidth is measured with a spectrum analyzer connected via a receive antenna placed near the EUT while the EUT is operating in transmission mode.

### 5.5.2 Test Environment conditions

- Ambient temperature : 21 °C,
- Relative Humidity : ( 50 - 53 ) % R.H.

### 5.5.3 Measurement Procedure

Please refer 5.5.1

### 5.5.4 Test setup

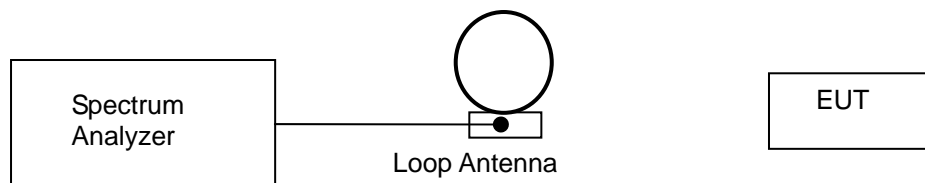

### 5.5.5 Measurement Result

Frequency	20 dB bandwidth
13.561 MHz	5.00 kHz

### 5.5.6 Test plot

