

Attachment 1. – Dipole Validation Plots

DIGITAL EMC CO., LTD

DUT: Dipole 835 MHz; Type: D835V2; Serial: D835V2 - SN:464

Communication System: CW; Frequency: 835 MHz; Duty Cycle: 1:1

Medium parameters used: $f = 835 \text{ MHz}$; $\sigma = 0.969 \text{ mho/m}$; $\epsilon_r = 53.6$; $\rho = 1000 \text{ kg/m}^3$

Phantom section: Flat Section

DASY4 Configuration:

Probe: EX3DV4 - SN3643; ConvF(9.12, 9.12, 9.12); Calibrated: 2012-01-27; Electronics: DAE3 Sn519

Phantom: SAM with 835MHz; Type: SAM; Serial: TP-1223

Measurement SW: DASY4, V4.7 Build 80; Postprocessing SW: SEMCAD, V1.8 Build 186

Test Date: 2012-08-26; Ambient Temp: 22.3; Tissue Temp: 22.5

Dipole Validation

Area Scan (61x81x1): Measurement grid: $dx=15\text{mm}$, $dy=15\text{mm}$

Zoom Scan (7x7x7)/Cube 0: Measurement grid: $dx=5\text{mm}$, $dy=5\text{mm}$, $dz=5\text{mm}$

Power Drift = 0.059 dB

Peak SAR (extrapolated) = 3.84 W/kg

SAR(1 g) = 2.56 mW/g; SAR(10 g) = 1.68 mW/g

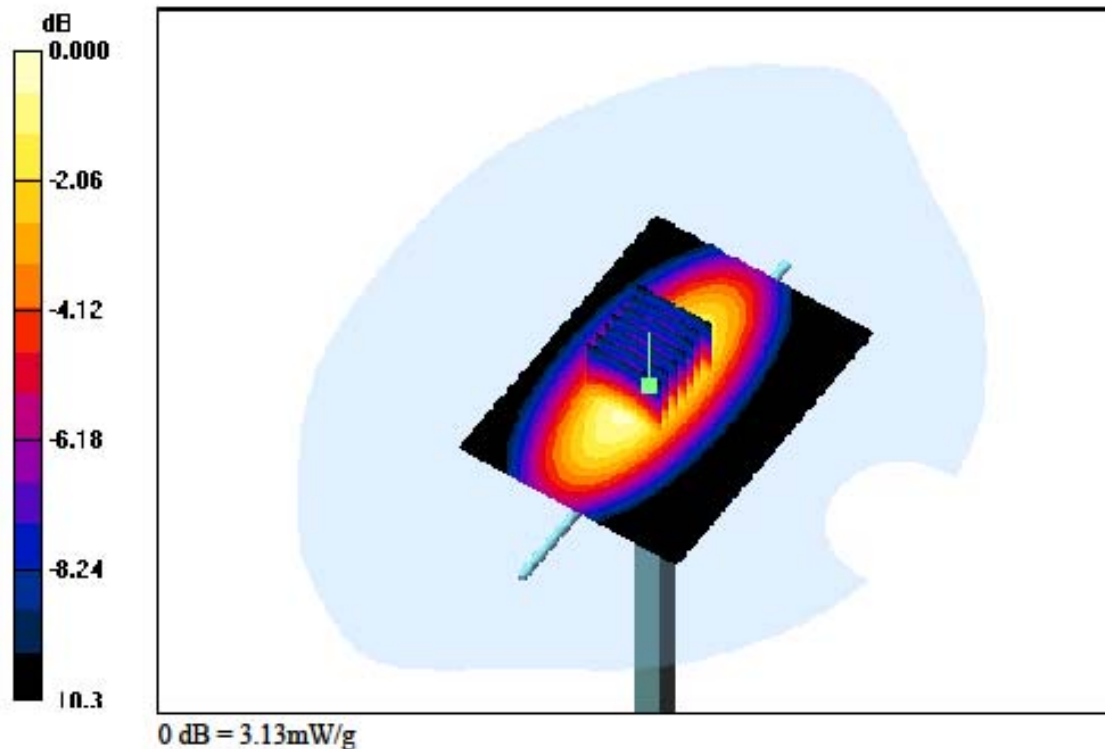

DIGITAL EMC CO., LTD

DUT: Dipole 835 MHz; Type: D835V2; Serial: D835V2 - SN:464

Communication System: CW; Frequency: 835 MHz; Duty Cycle: 1:1

Medium parameters used: $f = 835 \text{ MHz}$; $\sigma = 0.969 \text{ mho/m}$; $\epsilon_r = 53.6$; $\rho = 1000 \text{ kg/m}^3$

Phantom section: Flat Section

DASY4 Configuration:

Probe: EX3DV4 - SN3643; ConvF(9.12, 9.12, 9.12); Calibrated: 2012-01-27; Electronics: DAE3 Sn519

Phantom: SAM with 835MHz; Type: SAM; Serial: TP-1223

Measurement SW: DASY4, V4.7 Build 80; Postprocessing SW: SEMCAD, V1.8 Build 186

Test Date: 2012-08-26; Ambient Temp: 22.3; Tissue Temp: 22.5

Dipole Validation

Area Scan (61x81x1): Measurement grid: $dx=15\text{mm}$, $dy=15\text{mm}$

Zoom Scan (7x7x7)/Cube 0: Measurement grid: $dx=5\text{mm}$, $dy=5\text{mm}$, $dz=5\text{mm}$

Power Drift = 0.059 dB

Peak SAR (extrapolated) = 3.84 W/kg

SAR(1 g) = 2.56 mW/g; SAR(10 g) = 1.68 mW/g



DIGITAL EMC CO., LTD

DUT: Dipole 835 MHz; Type: D835V2; Serial: D835V2 - SN:464

Communication System: CW; Frequency: 835 MHz; Duty Cycle: 1:1

Medium parameters used: $f = 835 \text{ MHz}$; $\sigma = 0.969 \text{ mho/m}$; $\epsilon_r = 53.7$; $\rho = 1000 \text{ kg/m}^3$

Phantom section: Flat Section

DASY4 Configuration:

Probe: EX3DV4 - SN3643; ConvF(9.12, 9.12, 9.12); Calibrated: 2012-01-27; Electronics: DAE3 Sn519

Phantom: SAM with 835MHz; Type: SAM; Serial: TP-1223

Measurement SW: DASY4, V4.7 Build 80; Postprocessing SW: SEMCAD, V1.8 Build 186

Test Date: 2012-08-31; Ambient Temp: 22.3; Tissue Temp: 22.6

Dipole Validation

Area Scan (61x81x1): Measurement grid: $dx=15\text{mm}$, $dy=15\text{mm}$

Zoom Scan (7x7x7)/Cube 0: Measurement grid: $dx=5\text{mm}$, $dy=5\text{mm}$, $dz=5\text{mm}$

Power Drift = -0.020 dB

Peak SAR (extrapolated) = 3.80 W/kg

SAR(1 g) = 2.54 mW/g; SAR(10 g) = 1.67 mW/g

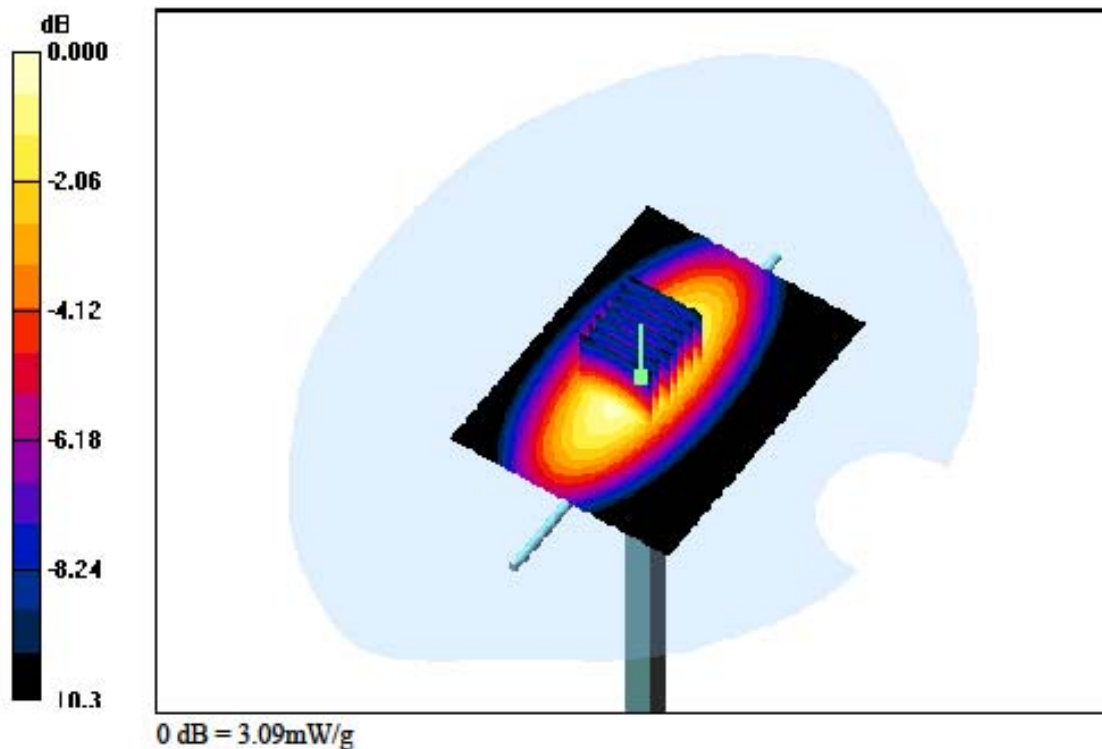

DIGITAL EMC CO., LTD

DUT: Dipole 835 MHz; Type: D835V2; Serial: D835V2 - SN:464

Communication System: CW; Frequency: 835 MHz; Duty Cycle: 1:1

Medium parameters used: $f = 835 \text{ MHz}$; $\sigma = 0.969 \text{ mho/m}$; $\epsilon_r = 53.7$; $\rho = 1000 \text{ kg/m}^3$

Phantom section: Flat Section

DASY4 Configuration:

Probe: EX3DV4 - SN3643; ConvF(9.12, 9.12, 9.12); Calibrated: 2012-01-27; Electronics: DAE3 Sn519

Phantom: SAM with 835MHz; Type: SAM; Serial: TP-1223

Measurement SW: DASY4, V4.7 Build 80; Postprocessing SW: SEMCAD, V1.8 Build 186

Test Date: 2012-08-31; Ambient Temp: 22.3; Tissue Temp: 22.6

Dipole Validation

Area Scan (61x81x1): Measurement grid: $dx=15\text{mm}$, $dy=15\text{mm}$

Zoom Scan (7x7x7)/Cube 0: Measurement grid: $dx=5\text{mm}$, $dy=5\text{mm}$, $dz=5\text{mm}$

Power Drift = -0.020 dB

Peak SAR (extrapolated) = 3.80 W/kg

SAR(1 g) = 2.54 mW/g; SAR(10 g) = 1.67 mW/g

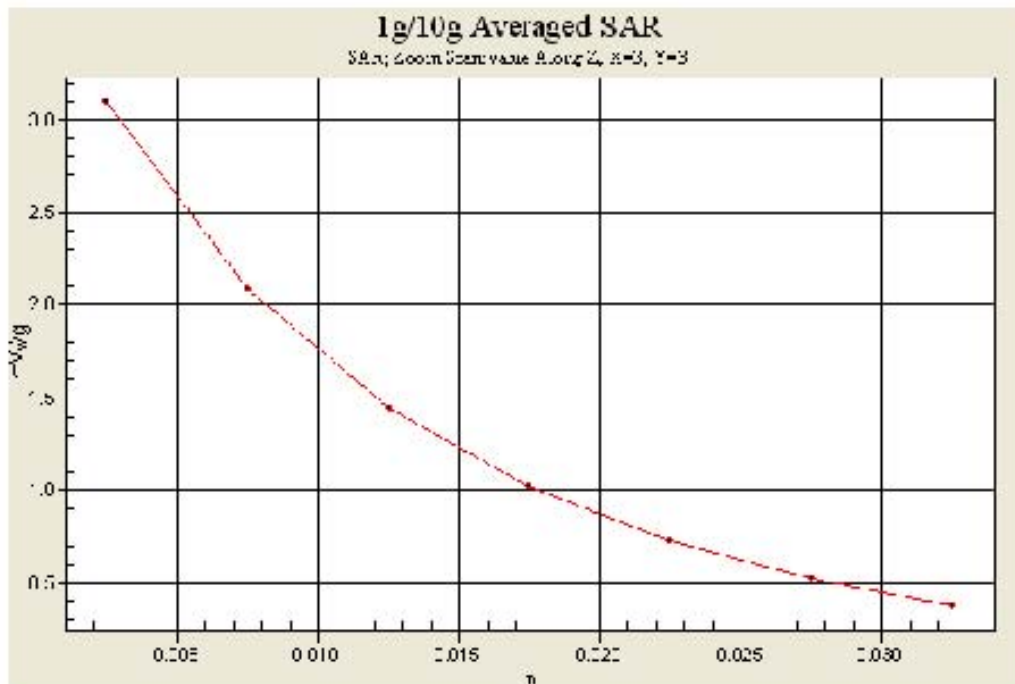

DIGITAL EMC CO., LTD

DUT: Dipole 1900 MHz; Type: D1900V2; Serial: D1900V2 - SN:5d029

Communication System: CW; Frequency: 1900 MHz; Duty Cycle: 1:1

Medium parameters used: $f = 1900$ MHz; $\sigma = 1.52$ mho/m; $\epsilon_r = 52.4$; $\rho = 1000$ kg/m³

Phantom section: Flat Section

DASY4 Configuration:

Probe: EX3DV4 - SN3643; ConvF(7.34, 7.34, 7.34); Calibrated: 2012-01-27; Electronics: DAE3 Sn519

Phantom: SAM 1800/1900 MHz; Type: SAM; Serial: TP-1224

Measurement SW: DASY4, V4.7 Build 80; Postprocessing SW: SEMCAD, V1.8 Build 186

Test Date: 2012-08-28; Ambient Temp: 22.4; Tissue Temp: 22.6

Dipole Validation

Area Scan (61x91x1): Measurement grid: dx=10mm, dy=10mm

Zoom Scan (7x7x7)/Cube 0: Measurement grid: dx=5mm, dy=5mm, dz=5mm

Power Drift = 0.050 dB

Peak SAR (extrapolated) = 18.6 W/kg

SAR(1 g) = 9.79 mW/g; SAR(10 g) = 5.03 mW/g

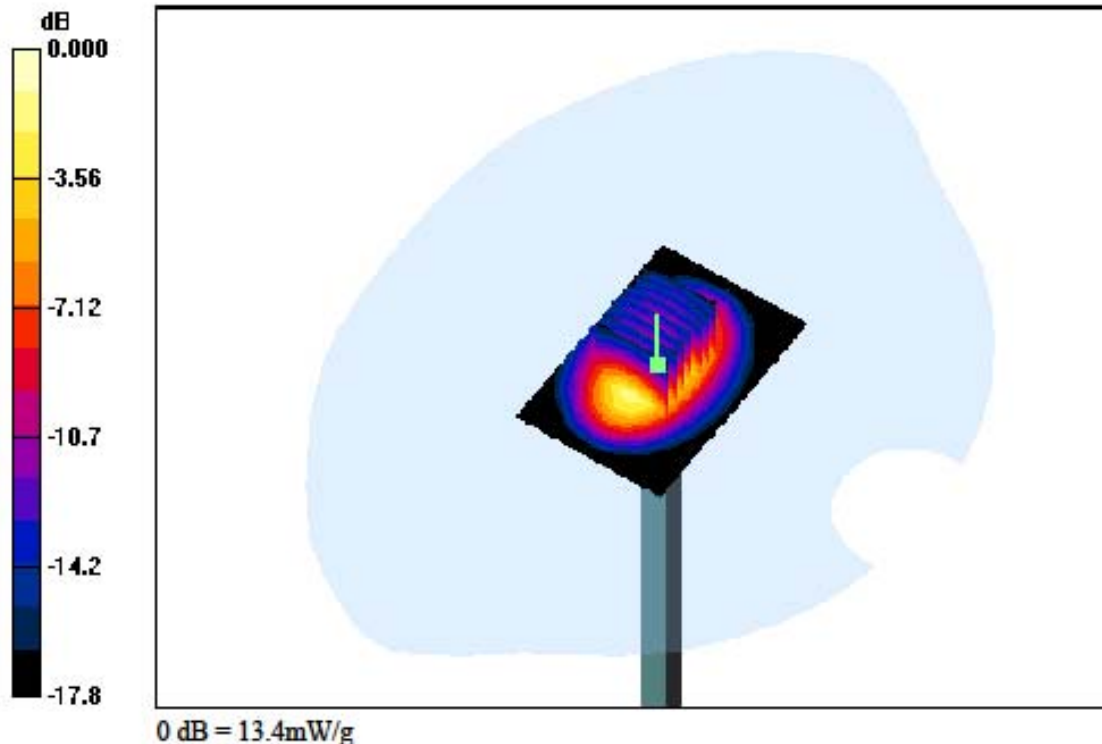

DIGITAL EMC CO., LTD

DUT: Dipole 1900 MHz; Type: D1900V2; Serial: D1900V2 - SN:5d029

Communication System: CW; Frequency: 1900 MHz; Duty Cycle: 1:1

Medium parameters used: $f = 1900$ MHz; $\sigma = 1.52$ mho/m; $\epsilon_r = 52.4$; $\rho = 1000$ kg/m³

Phantom section: Flat Section

DASY4 Configuration:

Probe: EX3DV4 - SN3643; ConvF(7.34, 7.34, 7.34); Calibrated: 2012-01-27; Electronics: DAE3 Sn519

Phantom: SAM 1800/1900 MHz; Type: SAM; Serial: TP-1224

Measurement SW: DASY4, V4.7 Build 80; Postprocessing SW: SEMCAD, V1.8 Build 186

Test Date: 2012-08-28; Ambient Temp: 22.4; Tissue Temp: 22.6

Dipole Validation

Area Scan (61x91x1): Measurement grid: dx=10mm, dy=10mm

Zoom Scan (7x7x7)/Cube 0: Measurement grid: dx=5mm, dy=5mm, dz=5mm

Power Drift = 0.050 dB

Peak SAR (extrapolated) = 18.6 W/kg

SAR(1 g) = 9.79 mW/g; SAR(10 g) = 5.03 mW/g



DIGITAL EMC CO., LTD

DUT: Dipole 1900 MHz; Type: D1900V2; Serial: D1900V2 - SN:5d029

Communication System: CW; Frequency: 1900 MHz; Duty Cycle: 1:1

Medium parameters used: $f = 1900$ MHz; $\sigma = 1.53$ mho/m; $\epsilon_r = 52.2$; $\rho = 1000$ kg/m³

Phantom section: Flat Section

DASY4 Configuration:

Probe: EX3DV4 - SN3643; ConvF(7.34, 7.34, 7.34); Calibrated: 2012-01-27; Electronics: DAE3 Sn519

Phantom: SAM 1800/1900 MHz; Type: SAM; Serial: TP-1224

Measurement SW: DASY4, V4.7 Build 80; Postprocessing SW: SEMCAD, V1.8 Build 186

Test Date: 2012-09-01; Ambient Temp: 22.1; Tissue Temp: 22.2

Dipole Validation

Area Scan (61x91x1): Measurement grid: dx=10mm, dy=10mm

Zoom Scan (7x7x7)/Cube 0: Measurement grid: dx=5mm, dy=5mm, dz=5mm

Power Drift = 0.053 dB

Peak SAR (extrapolated) = 18.9 W/kg

SAR(1 g) = 10 mW/g; SAR(10 g) = 5.17 mW/g

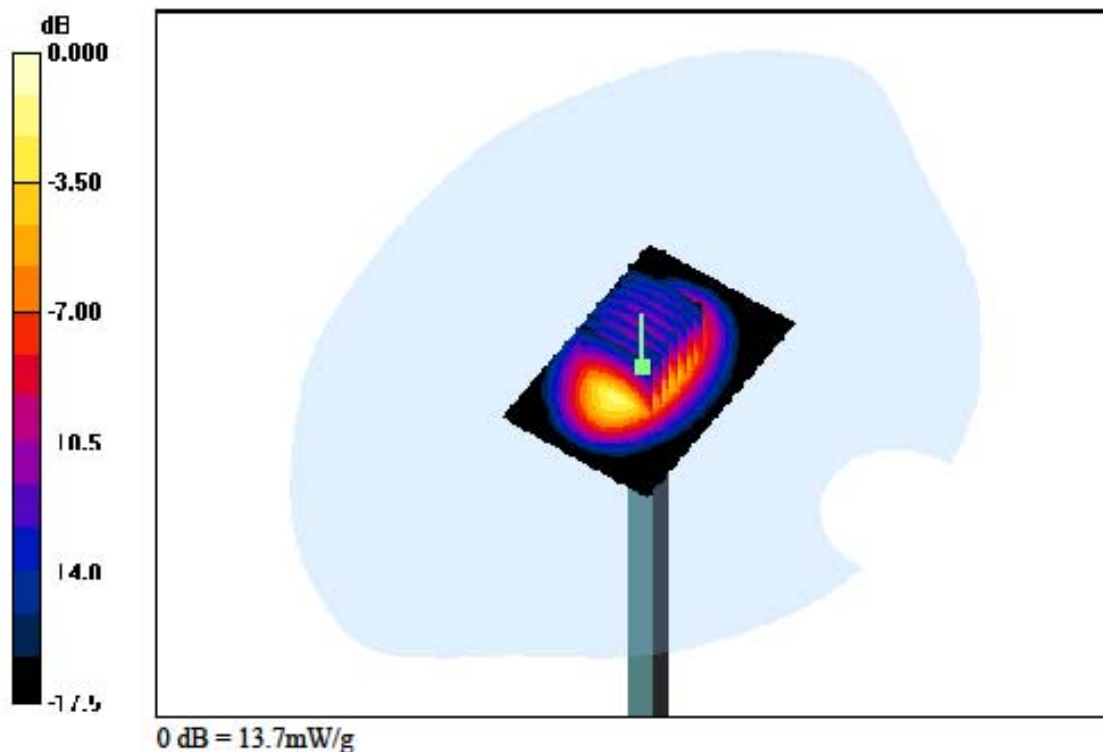

DIGITAL EMC CO., LTD

DUT: Dipole 1900 MHz; Type: D1900V2; Serial: D1900V2 - SN:5d029

Communication System: CW; Frequency: 1900 MHz; Duty Cycle: 1:1

Medium parameters used: $f = 1900$ MHz; $\sigma = 1.53$ mho/m; $\epsilon_r = 52.2$; $\rho = 1000$ kg/m³

Phantom section: Flat Section

DASY4 Configuration:

Probe: EX3DV4 - SN3643; ConvF(7.34, 7.34, 7.34); Calibrated: 2012-01-27; Electronics: DAE3 Sn519

Phantom: SAM 1800/1900 MHz; Type: SAM; Serial: TP-1224

Measurement SW: DASY4, V4.7 Build 80; Postprocessing SW: SEMCAD, V1.8 Build 186

Test Date: 2012-09-01; Ambient Temp: 22.1; Tissue Temp: 22.2

Dipole Validation

Area Scan (61x91x1): Measurement grid: dx=10mm, dy=10mm

Zoom Scan (7x7x7)/Cube 0: Measurement grid: dx=5mm, dy=5mm, dz=5mm

Power Drift = 0.053 dB

Peak SAR (extrapolated) = 18.9 W/kg

SAR(1 g) = 10 mW/g; SAR(10 g) = 5.17 mW/g



Attachment 2. – SAR Test Plots

DIGITAL EMC CO., LTD**DUT: BIP-1530; Type: PDA**

Communication System: GSM 850; Frequency: 836.6 MHz; Duty Cycle: 1:8.3
 Medium parameters used: $f = 836.6 \text{ MHz}$; $\sigma = 0.971 \text{ mho/m}$; $\epsilon_r = 53.6$; $\rho = 1000 \text{ kg/m}^3$
 Phantom section: Flat Section

DASY4 Configuration:

Probe: EX3DV4 - SN3643; ConvF(9.12, 9.12, 9.12); Calibrated: 2012-01-27; Electronics: DAE3 Sn519
 Phantom: SAM with 835MHz; Type: SAM; Serial: TP-1223
 Measurement SW: DASY4, V4.7 Build 80; Postprocessing SW: SEMCAD, V1.8 Build 186

Test Date: 2012-08-26 Ambient Temp: 22.3; Tissue Temp: 22.5

Touch from Body, Front, GSM850 Ch. 190, Ant Internal

Area Scan (81x161x1): Measurement grid: $dx=15\text{mm}$, $dy=15\text{mm}$
Zoom Scan (5x5x7)/Cube 0: Measurement grid: $dx=8\text{mm}$, $dy=8\text{mm}$, $dz=5\text{mm}$
 Power Drift = 0.183 dB
 Peak SAR (extrapolated) = 0.398 W/kg
 SAR(1 g) = 0.280 mW/g; SAR(10 g) = 0.188 mW/g

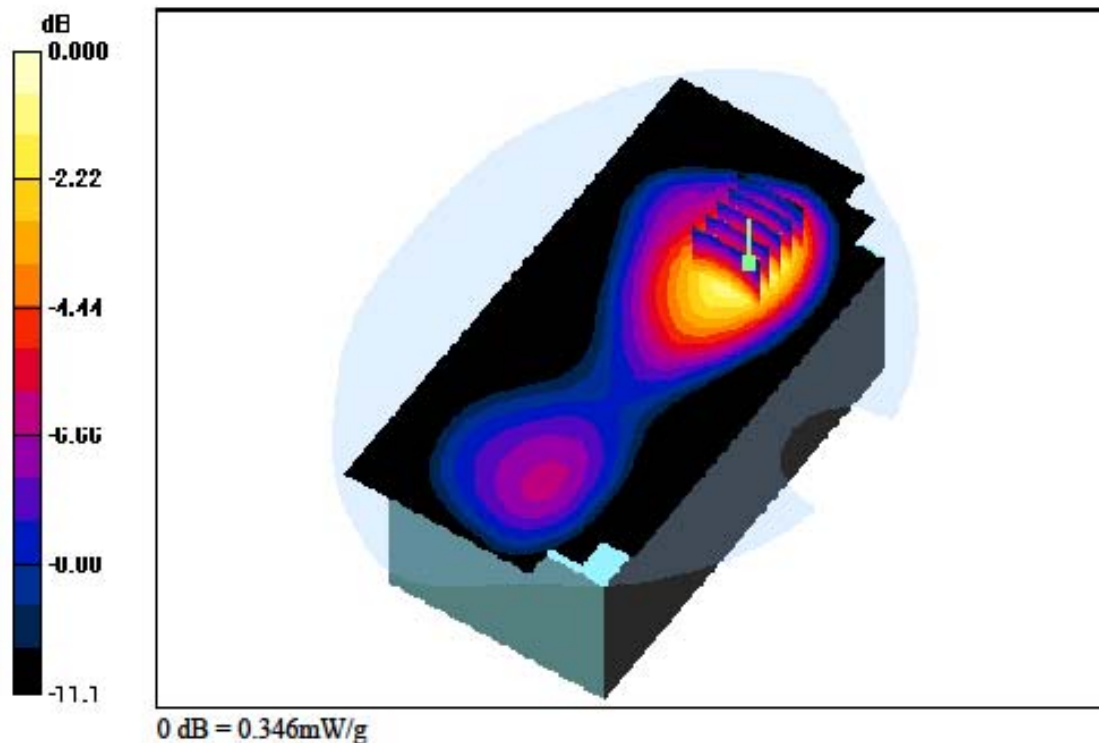

DIGITAL EMC CO., LTD**DUT: BIP-1530; Type: PDA**

Communication System: GSM 850; Frequency: 836.6 MHz; Duty Cycle: 1:8.3
Medium parameters used: $f = 836.6 \text{ MHz}$; $\sigma = 0.971 \text{ mho/m}$; $\epsilon_r = 53.6$; $\rho = 1000 \text{ kg/m}^3$
Phantom section: Flat Section

DASY4 Configuration:

Probe: EX3DV4 - SN3643; ConvF(9.12, 9.12, 9.12); Calibrated: 2012-01-27; Electronics: DAE3 Sn519
Phantom: SAM with 835MHz; Type: SAM; Serial: TP-1223
Measurement SW: DASY4, V4.7 Build 80; Postprocessing SW: SEMCAD, V1.8 Build 186

Test Date: 2012-08-26 Ambient Temp: 22.3; Tissue Temp: 22.5

Touch from Body, Front, GSM850 GPRS Class 8 Ch. 190, Ant Internal

Area Scan (81x161x1): Measurement grid: $dx=15\text{mm}$, $dy=15\text{mm}$
Zoom Scan (5x5x7)/Cube 0: Measurement grid: $dx=8\text{mm}$, $dy=8\text{mm}$, $dz=5\text{mm}$
Power Drift = 0.109 dB
Peak SAR (extrapolated) = 0.353 W/kg
SAR(1 g) = 0.250 mW/g; SAR(10 g) = 0.168 mW/g

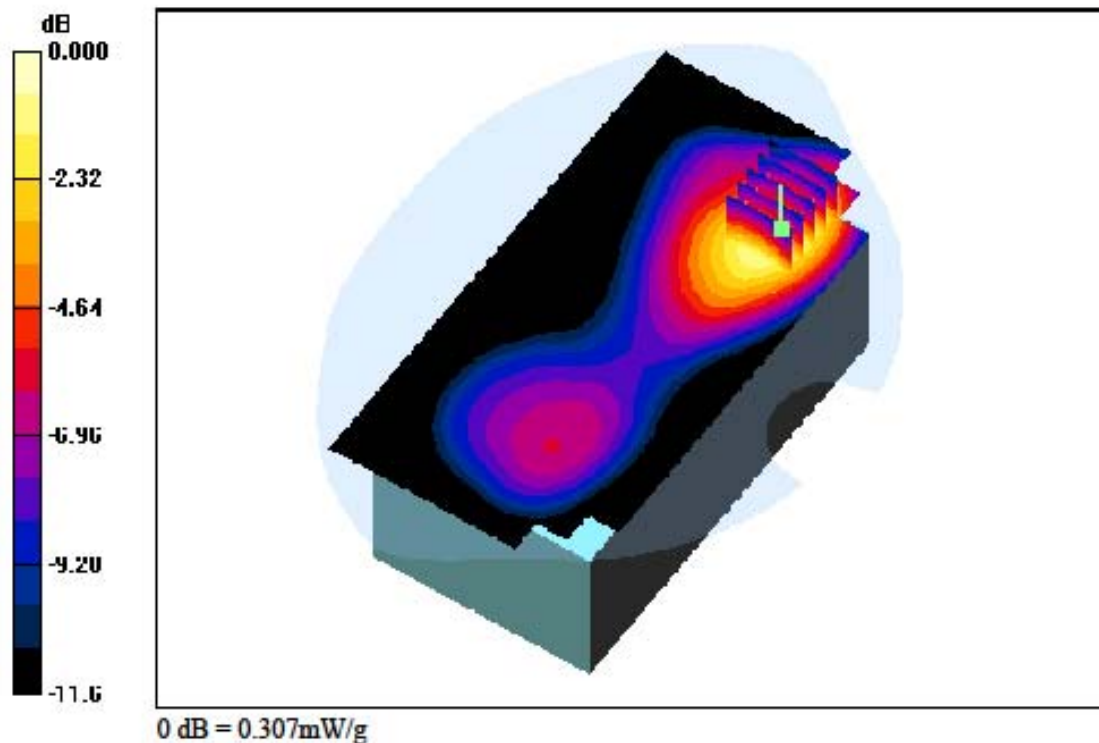

DIGITAL EMC CO., LTD**DUT: BIP-1530; Type: PDA**

Communication System: GSM 850; Frequency: 836.6 MHz; Duty Cycle: 1:4.15
Medium parameters used: $f = 836.6 \text{ MHz}$; $\sigma = 0.971 \text{ mho/m}$; $\epsilon_r = 53.6$; $\rho = 1000 \text{ kg/m}^3$
Phantom section: Flat Section

DASY4 Configuration:

Probe: EX3DV4 - SN3643; ConvF(9.12, 9.12, 9.12); Calibrated: 2012-01-27; Electronics: DAE3 Sn519
Phantom: SAM with 835MHz; Type: SAM; Serial: TP-1223
Measurement SW: DASY4, V4.7 Build 80; Postprocessing SW: SEMCAD, V1.8 Build 186

Test Date: 2012-08-26 Ambient Temp: 22.3; Tissue Temp: 22.5

Touch from Body, Front, GSM850 GPRS Class 10 Ch. 190, Ant Internal

Area Scan (81x161x1): Measurement grid: $dx=15\text{mm}$, $dy=15\text{mm}$
Zoom Scan (5x5x7)/Cube 0: Measurement grid: $dx=8\text{mm}$, $dy=8\text{mm}$, $dz=5\text{mm}$
Power Drift = 0.065 dB
Peak SAR (extrapolated) = 0.502 W/kg
SAR(1 g) = 0.349 mW/g; SAR(10 g) = 0.234 mW/g

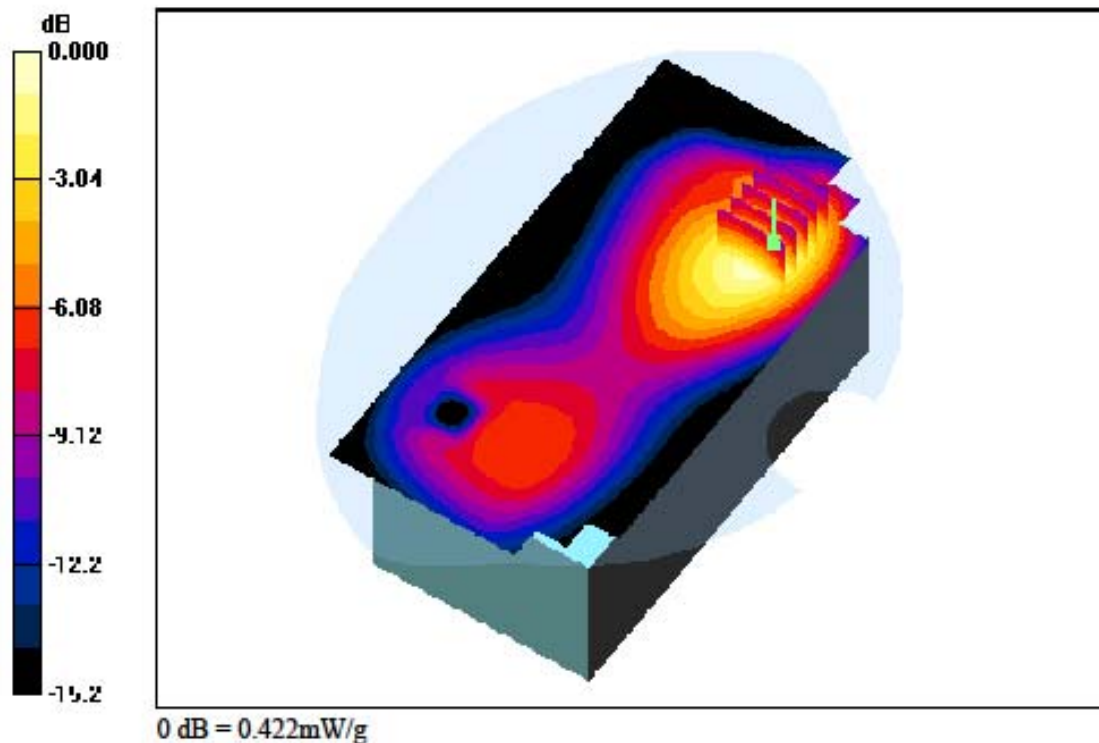

DIGITAL EMC CO., LTD**DUT: BIP-1530; Type: PDA**

Communication System: GSM 850; Frequency: 836.6 MHz; Duty Cycle: 1:4.15
Medium parameters used: $f = 836.6$ MHz; $\sigma = 0.971$ mho/m; $\epsilon_r = 53.6$; $\rho = 1000$ kg/m³
Phantom section: Flat Section

DASY4 Configuration:

Probe: EX3DV4 - SN3643; ConvF(9.12, 9.12, 9.12); Calibrated: 2012-01-27; Electronics: DAE3 Sn519
Phantom: SAM with 835MHz; Type: SAM; Serial: TP-1223
Measurement SW: DASY4, V4.7 Build 80; Postprocessing SW: SEMCAD, V1.8 Build 186

Test Date: 2012-08-26 Ambient Temp: 22.3; Tissue Temp: 22.5

Touch from Body, Rear, GSM850 GPRS Class 10 Ch. 190, Ant Internal

Area Scan (101x161x1): Measurement grid: dx=15mm, dy=15mm
Zoom Scan (5x5x7)/Cube 0: Measurement grid: dx=8mm, dy=8mm, dz=5mm
Power Drift = 0.156 dB
Peak SAR (extrapolated) = 0.062 W/kg
SAR(1 g) = 0.047 mW/g; SAR(10 g) = 0.036 mW/g

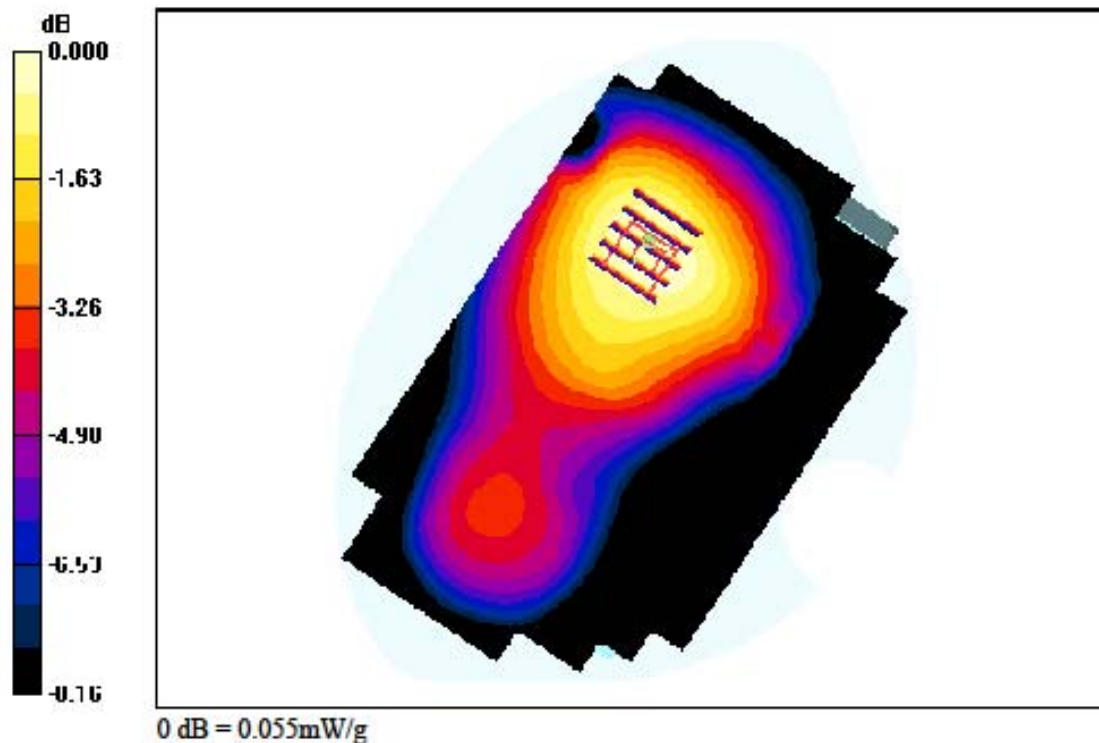

DIGITAL EMC CO., LTD**DUT: BIP-1530; Type: PDA**

Communication System: GSM 850; Frequency: 836.6 MHz; Duty Cycle: 1:4.15
 Medium parameters used: $f = 836.6 \text{ MHz}$; $\sigma = 0.971 \text{ mho/m}$; $\epsilon_r = 53.6$; $\rho = 1000 \text{ kg/m}^3$
 Phantom section: Flat Section

DASY4 Configuration:

Probe: EX3DV4 - SN3643; ConvF(9.12, 9.12, 9.12); Calibrated: 2012-01-27; Electronics: DAE3 Sn519
 Phantom: SAM with 835MHz; Type: SAM; Serial: TP-1223
 Measurement SW: DASY4, V4.7 Build 80; Postprocessing SW: SEMCAD, V1.8 Build 186

Test Date: 2012-08-26 Ambient Temp: 22.3; Tissue Temp: 22.5

Touch from Body, Sim2, Front, GSM850 GPRS Class 10 Ch. 190, Ant Internal

Area Scan (81x161x1): Measurement grid: $dx=15\text{mm}$, $dy=15\text{mm}$
Zoom Scan (5x5x7)/Cube 0: Measurement grid: $dx=8\text{mm}$, $dy=8\text{mm}$, $dz=5\text{mm}$
 Power Drift = -0.190 dB
 Peak SAR (extrapolated) = 0.489 W/kg
 SAR(1 g) = 0.346 mW/g; SAR(10 g) = 0.232 mW/g

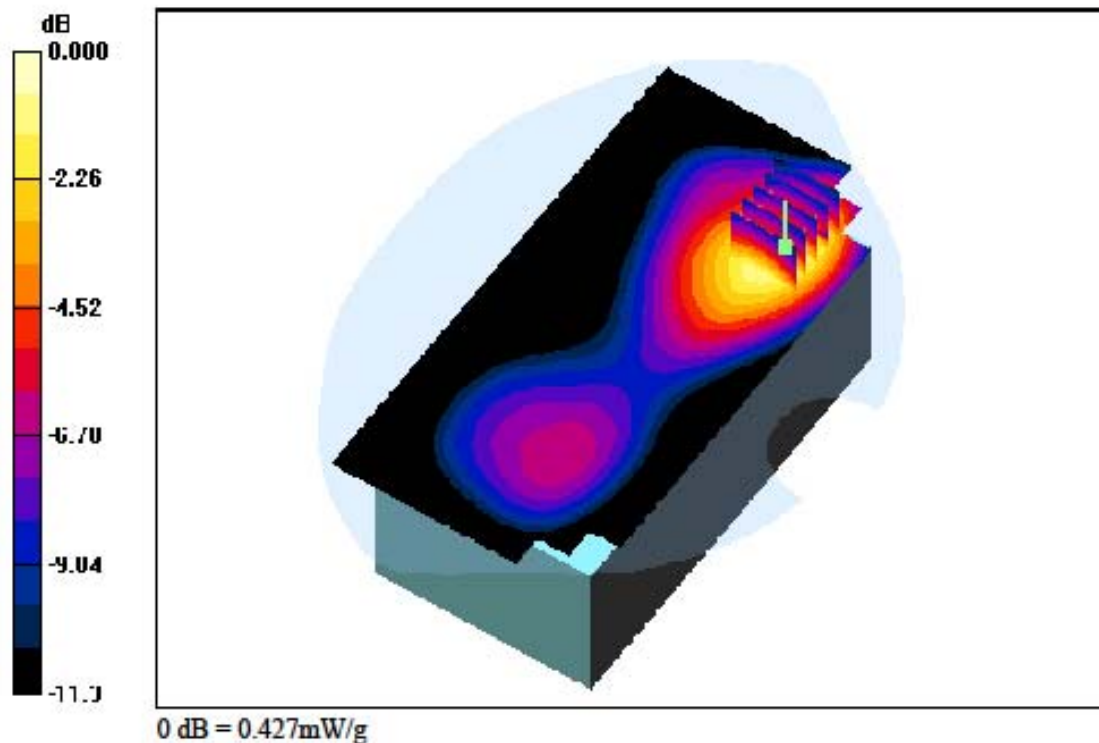

DIGITAL EMC CO., LTD**DUT: BIP-1530; Type: PDA**

Communication System: GSM 850; Frequency: 836.6 MHz; Duty Cycle: 1:4.15
Medium parameters used: $f = 836.6 \text{ MHz}$; $\sigma = 0.971 \text{ mho/m}$; $\epsilon_r = 53.6$; $\rho = 1000 \text{ kg/m}^3$
Phantom section: Flat Section

DASY4 Configuration:

Probe: EX3DV4 - SN3643; ConvF(9.12, 9.12, 9.12); Calibrated: 2012-01-27; Electronics: DAE3 Sn519
Phantom: SAM with 835MHz; Type: SAM; Serial: TP-1223
Measurement SW: DASY4, V4.7 Build 80; Postprocessing SW: SEMCAD, V1.8 Build 186

Test Date: 2012-08-26 Ambient Temp: 22.3; Tissue Temp: 22.5

Touch from Body, RFID, Front, GSM850 GPRS Class 10 Ch. 190, Ant Internal

Area Scan (81x161x1): Measurement grid: $dx=15\text{mm}$, $dy=15\text{mm}$
Zoom Scan (5x5x7)/Cube 0: Measurement grid: $dx=8\text{mm}$, $dy=8\text{mm}$, $dz=5\text{mm}$
Power Drift = 0.016 dB
Peak SAR (extrapolated) = 0.486 W/kg
SAR(1 g) = 0.343 mW/g; SAR(10 g) = 0.231 mW/g

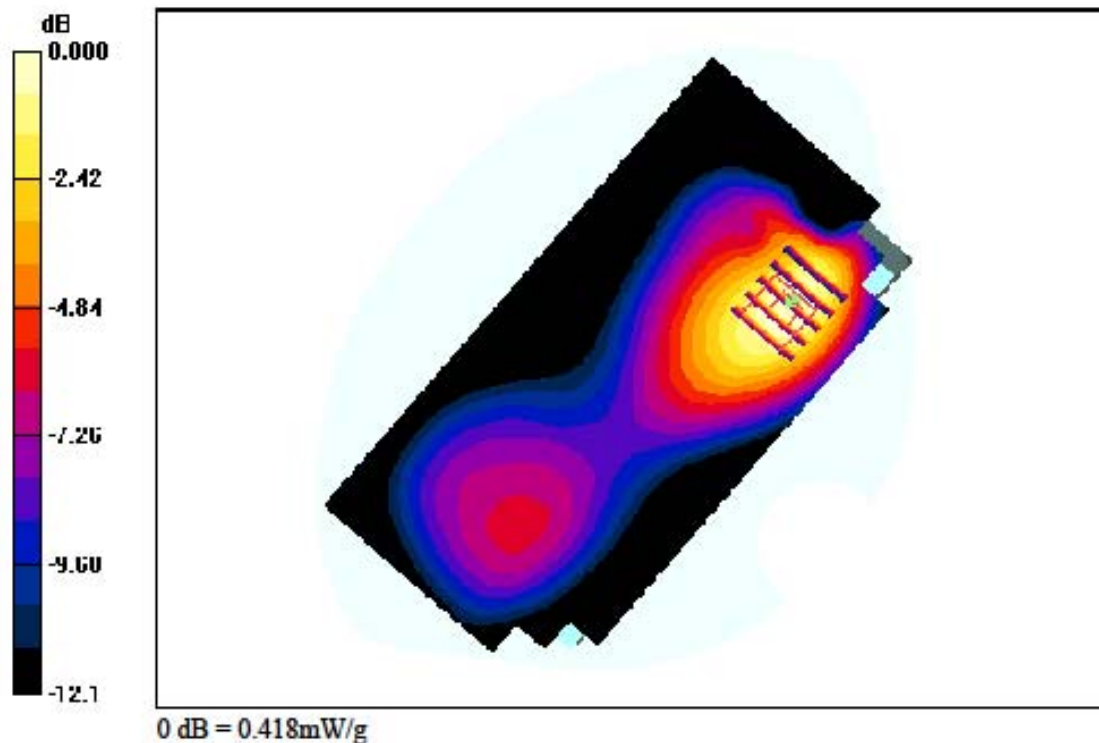

DIGITAL EMC CO., LTD**DUT: BIP-1530; Type: PDA**

Communication System: GSM 850; Frequency: 836.6 MHz; Duty Cycle: 1:4.15
Medium parameters used: $f = 836.6 \text{ MHz}$; $\sigma = 0.971 \text{ mho/m}$; $\epsilon_r = 53.6$; $\rho = 1000 \text{ kg/m}^3$
Phantom section: Flat Section

DASY4 Configuration:

Probe: EX3DV4 - SN3643; ConvF(9.12, 9.12, 9.12); Calibrated: 2012-01-27; Electronics: DAE3 Sn519
Phantom: SAM with 835MHz; Type: SAM; Serial: TP-1223
Measurement SW: DASY4, V4.7 Build 80; Postprocessing SW: SEMCAD, V1.8 Build 186

Test Date: 2012-08-26 Ambient Temp: 22.3; Tissue Temp: 22.5

Touch from Body, Card Reader, Front, GSM850 GPRS Class 10 Ch. 190, Ant Internal

Area Scan (81x161x1): Measurement grid: $dx=15\text{mm}$, $dy=15\text{mm}$
Zoom Scan (5x5x7)/Cube 0: Measurement grid: $dx=8\text{mm}$, $dy=8\text{mm}$, $dz=5\text{mm}$
Power Drift = -0.024 dB
Peak SAR (extrapolated) = 0.472 W/kg
SAR(1 g) = 0.337 mW/g; SAR(10 g) = 0.227 mW/g

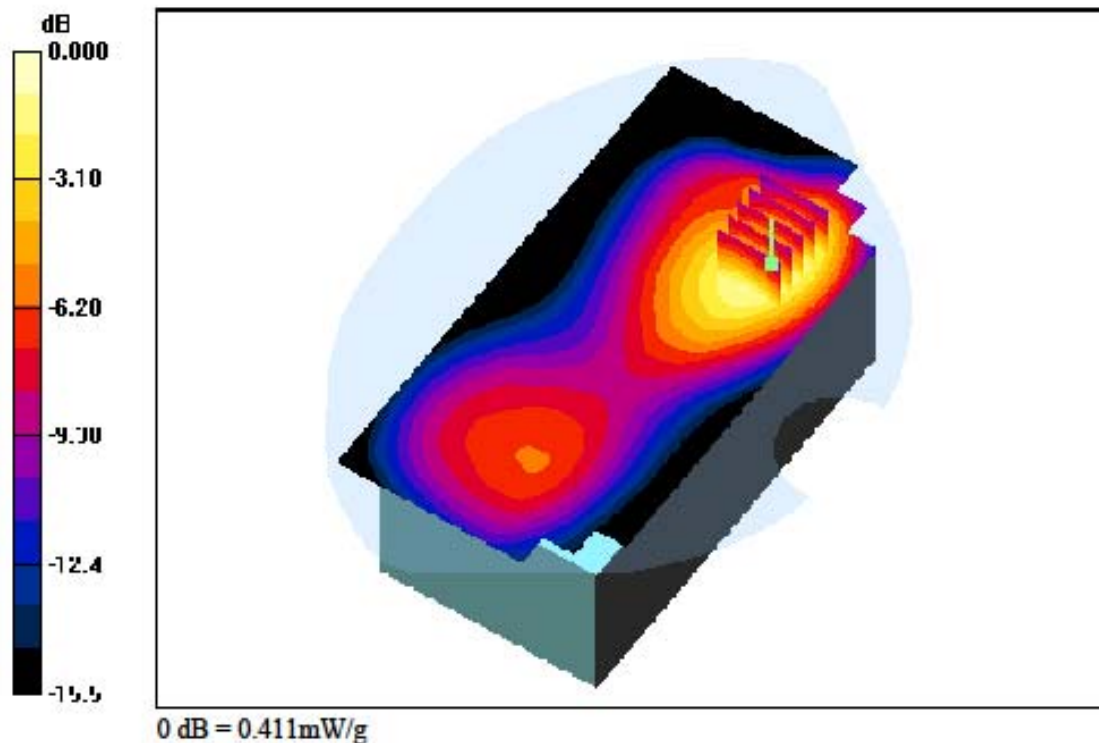

DIGITAL EMC CO., LTD**DUT: BIP-1530; Type: PDA**

Communication System: GSM 850; Frequency: 836.6 MHz; Duty Cycle: 1:4.15
Medium parameters used: $f = 836.6 \text{ MHz}$; $\sigma = 0.971 \text{ mho/m}$; $\epsilon_r = 53.6$; $\rho = 1000 \text{ kg/m}^3$
Phantom section: Flat Section

DASY4 Configuration:

Probe: EX3DV4 - SN3643; ConvF(9.12, 9.12, 9.12); Calibrated: 2012-01-27; Electronics: DAE3 Sn519
Phantom: SAM with 835MHz; Type: SAM; Serial: TP-1223
Measurement SW: DASY4, V4.7 Build 80; Postprocessing SW: SEMCAD, V1.8 Build 186

Test Date: 2012-08-26 Ambient Temp: 22.3; Tissue Temp: 22.5

Touch from Body, Finger Printer, Front, GSM850 GPRS Class 10 Ch. 190, Ant Internal

Area Scan (81x161x1): Measurement grid: $dx=15\text{mm}$, $dy=15\text{mm}$
Zoom Scan (5x5x7)/Cube 0: Measurement grid: $dx=8\text{mm}$, $dy=8\text{mm}$, $dz=5\text{mm}$
Power Drift = 0.044 dB
Peak SAR (extrapolated) = 0.476 W/kg
SAR(1 g) = 0.337 mW/g; SAR(10 g) = 0.228 mW/g

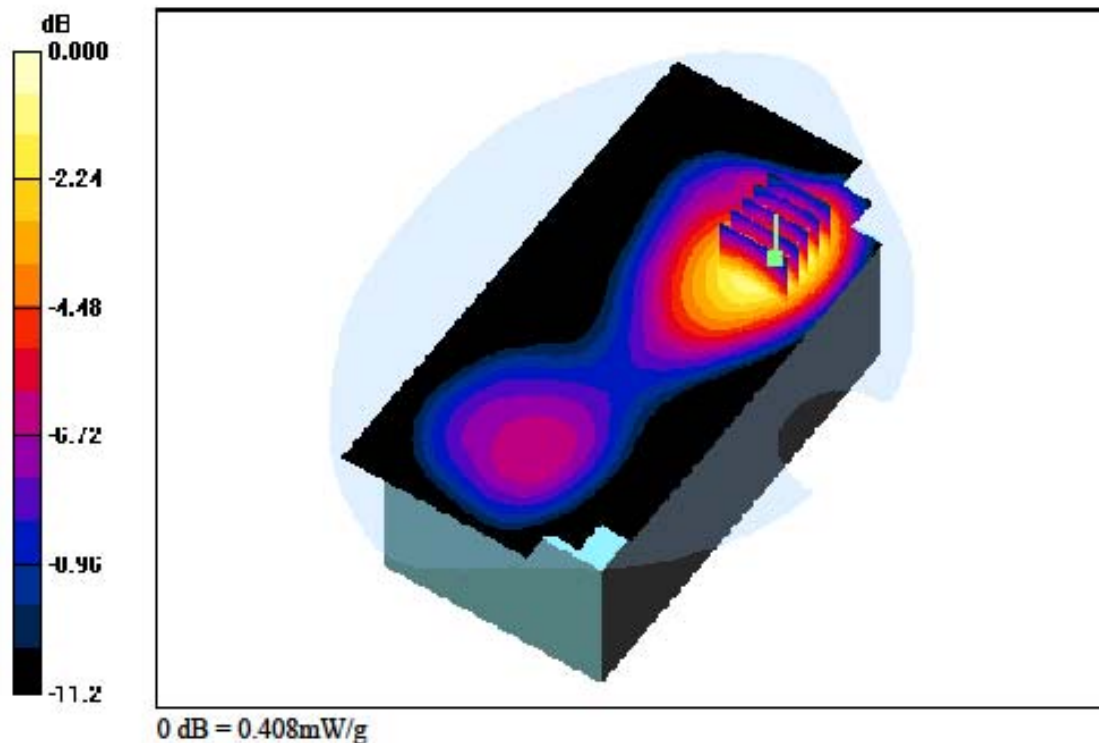

DIGITAL EMC CO., LTD

DUT: BIP-1530; Type: PDA

Communication System: PCS1900; Frequency: 1880 MHz; Duty Cycle: 1:8.3
Medium parameters used: $f = 1880$ MHz; $\sigma = 1.5$ mho/m; $\epsilon_r = 52.4$; $\rho = 1000$ kg/m³
Phantom section: Flat Section

DASY4 Configuration:

Probe: EX3DV4 - SN3643; ConvF(7.34, 7.34, 7.34); Calibrated: 2012-01-27; Electronics: DAE3 Sn519
Phantom: SAM 1800/1900 MHz; Type: SAM; Serial: TP-1224
Measurement SW: DASY4, V4.7 Build 80; Postprocessing SW: SEMCAD, V1.8 Build 186

Test Date: 2012-08-28 Ambient Temp: 22.4; Tissue Temp: 22.6

Touch from Body, Front, PCS1900 Ch. 661, Ant Internal

Area Scan (81x151x1): Measurement grid: dx=15mm, dy=15mm
Zoom Scan (5x5x7)/Cube 0: Measurement grid: dx=8mm, dy=8mm, dz=5mm
Power Drift = 0.005 dB
Peak SAR (extrapolated) = 0.120 W/kg
SAR(1 g) = 0.074 mW/g; SAR(10 g) = 0.048 mW/g

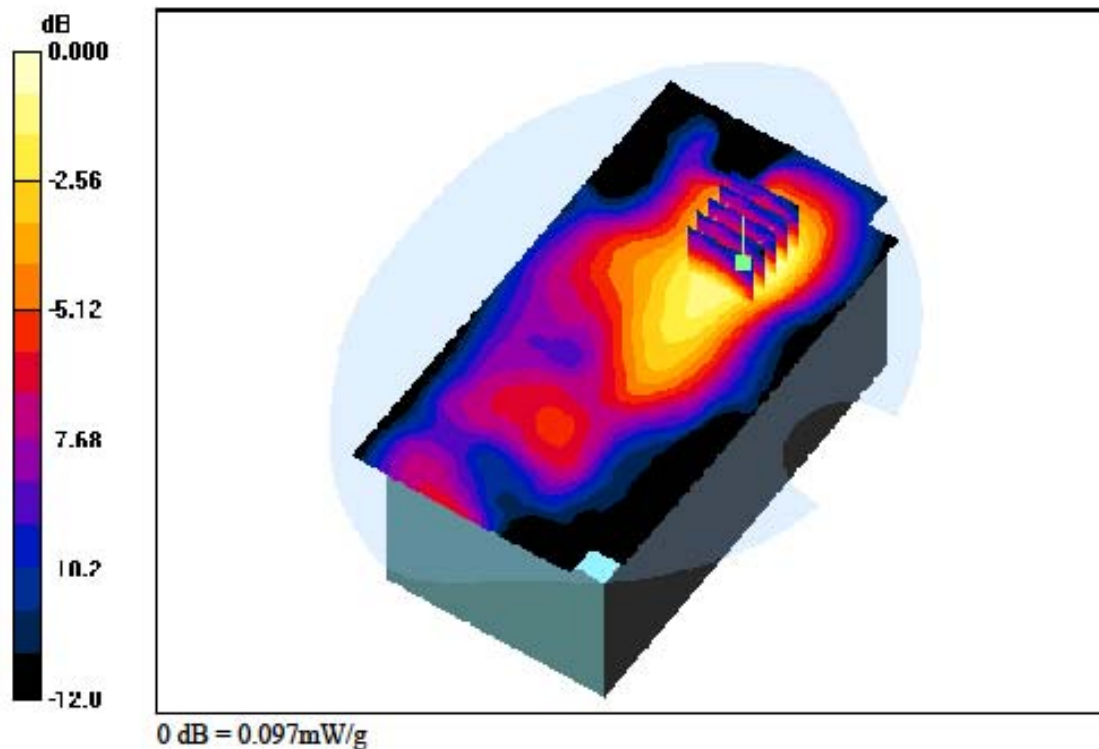

DIGITAL EMC CO., LTD**DUT: BIP-1530; Type: PDA**

Communication System: PCS1900; Frequency: 1880 MHz; Duty Cycle: 1:8.3
 Medium parameters used: $f = 1880 \text{ MHz}$; $\sigma = 1.5 \text{ mho/m}$; $\epsilon_r = 52.4$; $\rho = 1000 \text{ kg/m}^3$
 Phantom section: Flat Section

DASY4 Configuration:

Probe: EX3DV4 - SN3643; ConvF(7.34, 7.34, 7.34); Calibrated: 2012-01-27; Electronics: DAE3 Sn519
 Phantom: SAM 1800/1900 MHz; Type: SAM; Serial: TP-1224
 Measurement SW: DASY4, V4.7 Build 80; Postprocessing SW: SEMCAD, V1.8 Build 186

Test Date: 2012-08-28 Ambient Temp: 22.4; Tissue Temp: 22.6

Touch from Body, Front, PCS1900 GPRS Class 8 Ch. 661, Ant Internal

Area Scan (81x151x1): Measurement grid: $dx=15\text{mm}$, $dy=15\text{mm}$
Zoom Scan (5x5x7)/Cube 0: Measurement grid: $dx=8\text{mm}$, $dy=8\text{mm}$, $dz=5\text{mm}$
 Power Drift = 0.200 dB
 Peak SAR (extrapolated) = 0.116 W/kg
 SAR(1 g) = 0.077 mW/g; SAR(10 g) = 0.049 mW/g

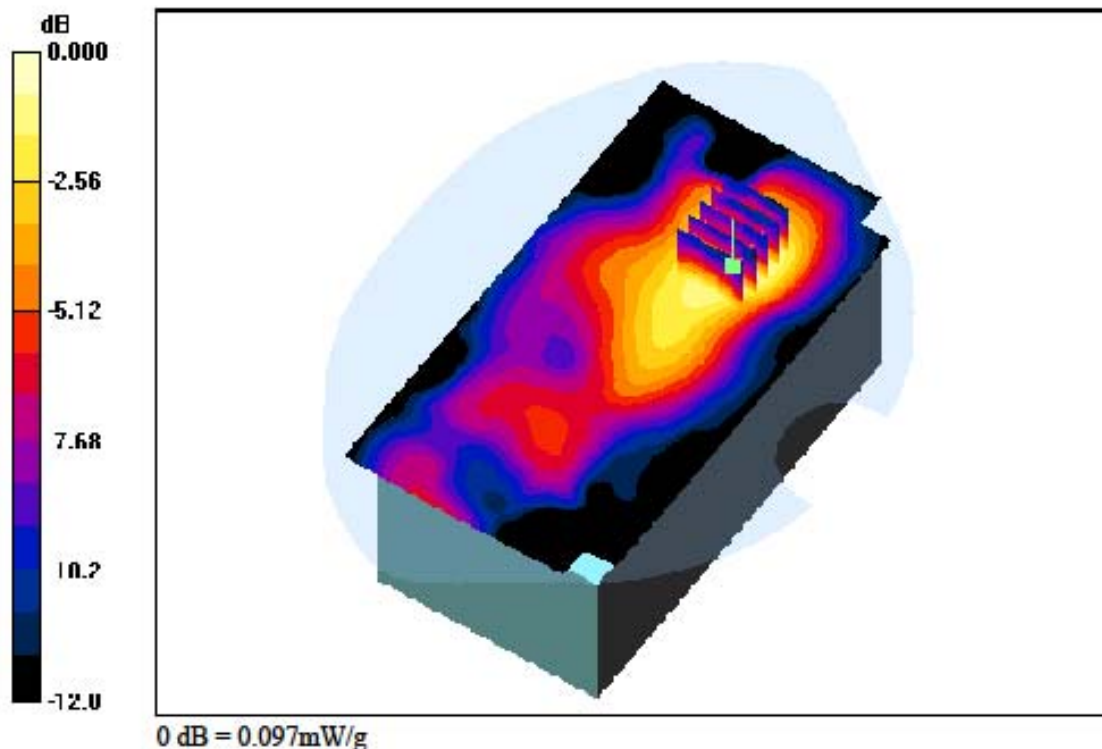

DIGITAL EMC CO., LTD**DUT: BIP-1530; Type: PDA**

Communication System: PCS1900; Frequency: 1880 MHz; Duty Cycle: 1:4.15
 Medium parameters used: $f = 1880$ MHz; $\sigma = 1.5$ mho/m; $\epsilon_r = 52.4$; $\rho = 1000$ kg/m³
 Phantom section: Flat Section

DASY4 Configuration:

Probe: EX3DV4 - SN3643; ConvF(7.34, 7.34, 7.34); Calibrated: 2012-01-27; Electronics: DAE3 Sn519
 Phantom: SAM 1800/1900 MHz; Type: SAM; Serial: TP-1224
 Measurement SW: DASY4, V4.7 Build 80; Postprocessing SW: SEMCAD, V1.8 Build 186

Test Date: 2012-08-28 Ambient Temp: 22.4; Tissue Temp: 22.6

Touch from Body, Front, PCS1900 GPRS Class 10 Ch. 661, Ant Internal

Area Scan (81x151x1): Measurement grid: dx=15mm, dy=15mm
Zoom Scan (5x5x7)/Cube 0: Measurement grid: dx=8mm, dy=8mm, dz=5mm
 Power Drift = 0.117 dB
 Peak SAR (extrapolated) = 0.192 W/kg
 SAR(1 g) = 0.118 mW/g; SAR(10 g) = 0.074 mW/g

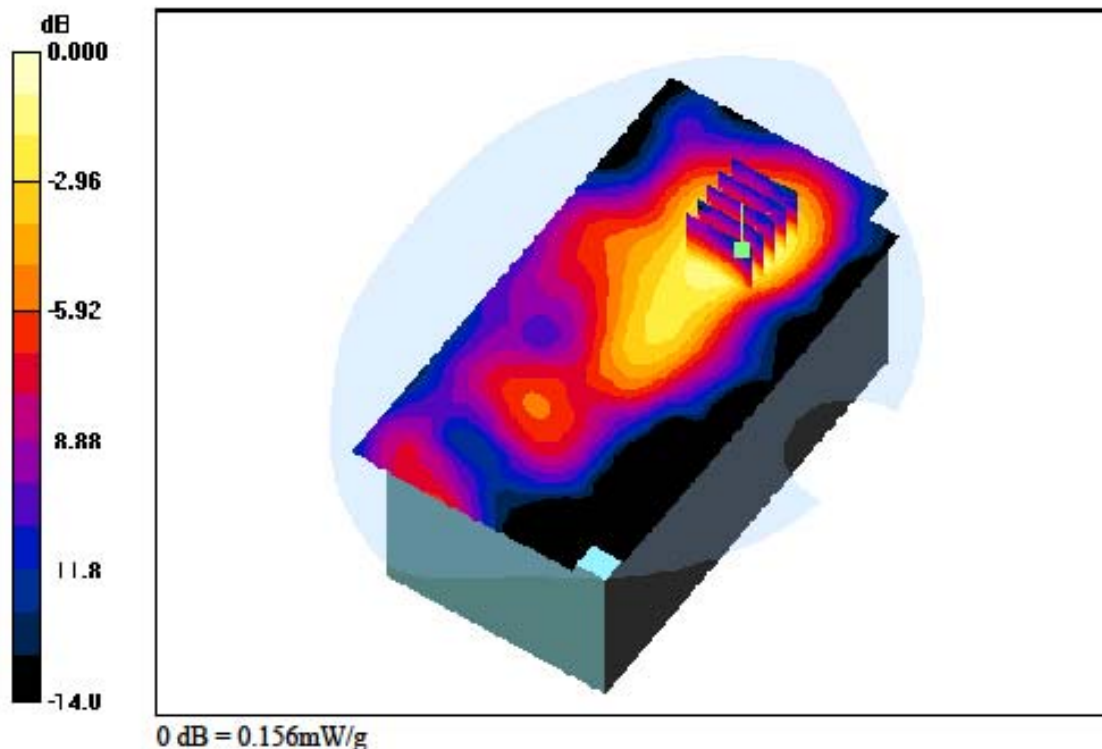

DIGITAL EMC CO., LTD**DUT: BIP-1530; Type: PDA**

Communication System: PCS1900; Frequency: 1880 MHz; Duty Cycle: 1:4.15
Medium parameters used: $f = 1880$ MHz; $\sigma = 1.5$ mho/m; $\epsilon_r = 52.4$; $\rho = 1000$ kg/m³
Phantom section: Flat Section

DASY4 Configuration:

Probe: EX3DV4 - SN3643; ConvF(7.34, 7.34, 7.34); Calibrated: 2012-01-27; Electronics: DAE3 Sn519
Phantom: SAM 1800/1900 MHz; Type: SAM; Serial: TP-1224
Measurement SW: DASY4, V4.7 Build 80; Postprocessing SW: SEMCAD, V1.8 Build 186

Test Date: 2012-08-28 Ambient Temp: 22.4; Tissue Temp: 22.6

Touch from Body, Rear, PCS1900 GPRS Class 10 Ch. 661, Ant Internal

Area Scan (91x151x1): Measurement grid: dx=15mm, dy=15mm
Zoom Scan (5x5x7)/Cube 0: Measurement grid: dx=8mm, dy=8mm, dz=5mm
Power Drift = 0.122 dB
Peak SAR (extrapolated) = 0.057 W/kg
SAR(1 g) = 0.036 mW/g; SAR(10 g) = 0.024 mW/g

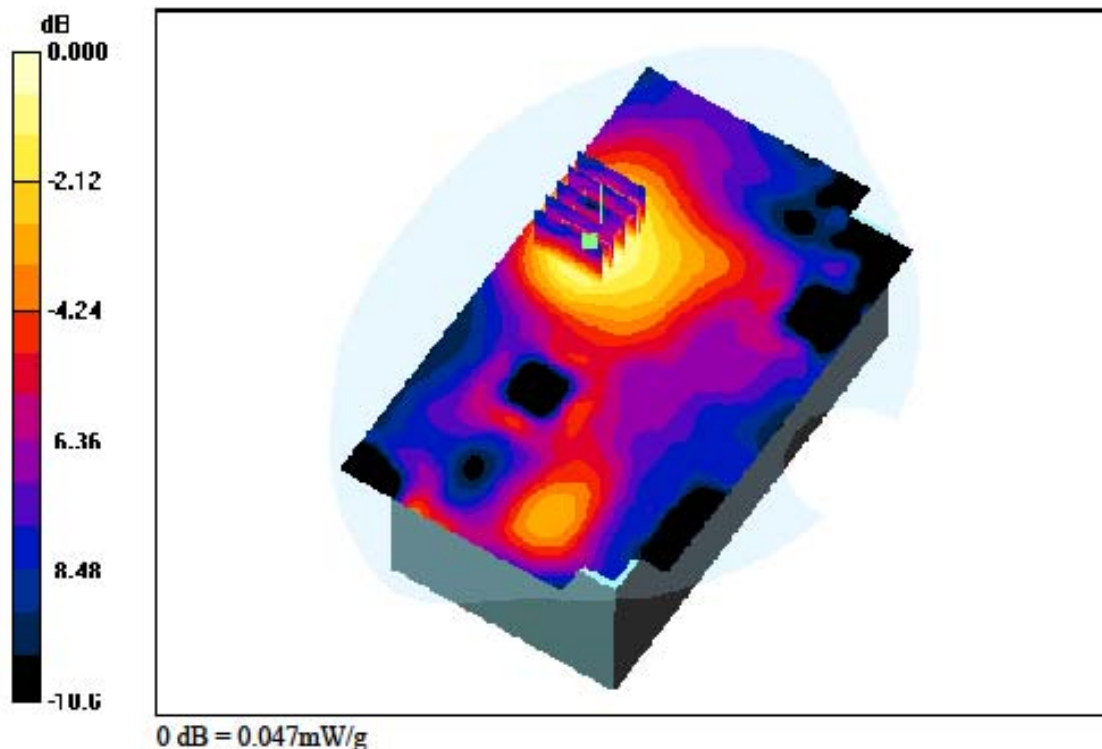

DIGITAL EMC CO., LTD**DUT: BIP-1530; Type: PDA**

Communication System: PCS1900; Frequency: 1880 MHz; Duty Cycle: 1:4.15
Medium parameters used: $f = 1880$ MHz; $\sigma = 1.5$ mho/m; $\epsilon_r = 52.4$; $\rho = 1000$ kg/m³
Phantom section: Flat Section

DASY4 Configuration:

Probe: EX3DV4 - SN3643; ConvF(7.34, 7.34, 7.34); Calibrated: 2012-01-27; Electronics: DAE3 Sn519
Phantom: SAM 1800/1900 MHz; Type: SAM; Serial: TP-1224
Measurement SW: DASY4, V4.7 Build 80; Postprocessing SW: SEMCAD, V1.8 Build 186

Test Date: 2012-08-28 Ambient Temp: 22.4; Tissue Temp: 22.6

Touch from Body, Sim2, Front, PCS1900 GPRS Class 10 Ch. 661, Ant Internal

Area Scan (81x151x1): Measurement grid: dx=15mm, dy=15mm
Zoom Scan (5x5x7)/Cube 0: Measurement grid: dx=8mm, dy=8mm, dz=5mm
Power Drift = 0.039 dB
Peak SAR (extrapolated) = 0.193 W/kg
SAR(1 g) = 0.118 mW/g; SAR(10 g) = 0.073 mW/g

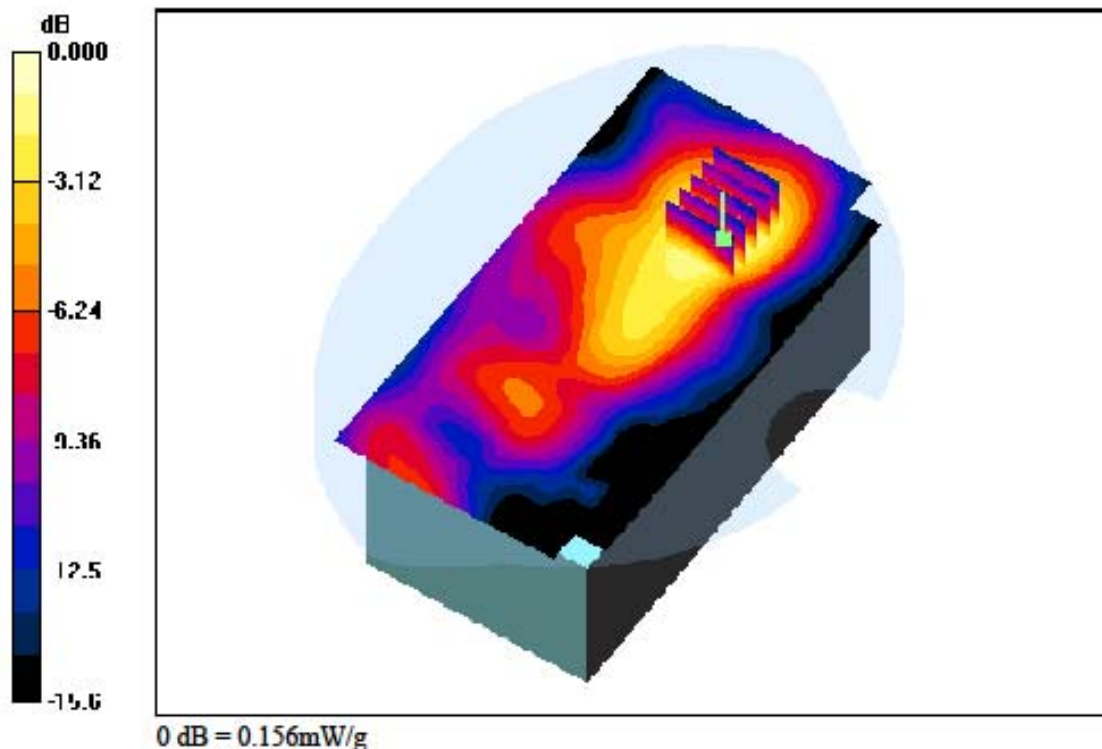

DIGITAL EMC CO., LTD**DUT: BIP-1530; Type: PDA**

Communication System: PCS1900; Frequency: 1880 MHz; Duty Cycle: 1:4.15
Medium parameters used: $f = 1880$ MHz; $\sigma = 1.5$ mho/m; $\epsilon_r = 52.4$; $\rho = 1000$ kg/m³
Phantom section: Flat Section

DASY4 Configuration:

Probe: EX3DV4 - SN3643; ConvF(7.34, 7.34, 7.34); Calibrated: 2012-01-27; Electronics: DAE3 Sn519
Phantom: SAM 1800/1900 MHz; Type: SAM; Serial: TP-1224
Measurement SW: DASY4, V4.7 Build 80; Postprocessing SW: SEMCAD, V1.8 Build 186

Test Date: 2012-08-28 Ambient Temp: 22.4; Tissue Temp: 22.6

Touch from Body, RFID, Front, PCS1900 GPRS Class 10 Ch. 661, Ant Internal

Area Scan (81x151x1): Measurement grid: $dx=15$ mm, $dy=15$ mm
Zoom Scan (5x5x7)/Cube 0: Measurement grid: $dx=8$ mm, $dy=8$ mm, $dz=5$ mm
Power Drift = 0.083 dB
Peak SAR (extrapolated) = 0.194 W/kg
SAR(1 g) = 0.118 mW/g; SAR(10 g) = 0.073 mW/g

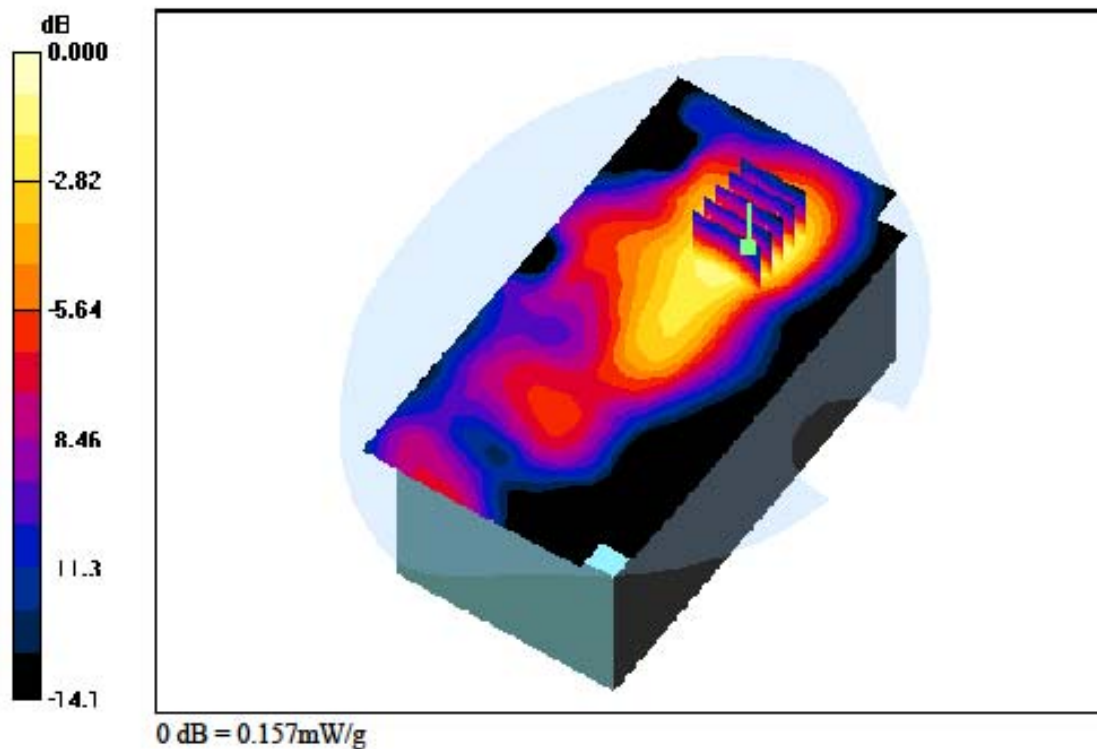

DIGITAL EMC CO., LTD**DUT: BIP-1530; Type: PDA**

Communication System: PCS1900; Frequency: 1880 MHz; Duty Cycle: 1:4.15
Medium parameters used: $f = 1880$ MHz; $\sigma = 1.5$ mho/m; $\epsilon_r = 52.4$; $\rho = 1000$ kg/m³
Phantom section: Flat Section

DASY4 Configuration:

Probe: EX3DV4 - SN3643; ConvF(7.34, 7.34, 7.34); Calibrated: 2012-01-27; Electronics: DAE3 Sn519
Phantom: SAM 1800/1900 MHz; Type: SAM; Serial: TP-1224
Measurement SW: DASY4, V4.7 Build 80; Postprocessing SW: SEMCAD, V1.8 Build 186

Test Date: 2012-08-28 Ambient Temp: 22.4; Tissue Temp: 22.6

Touch from Body, Card Reader, Front, PCS1900 GPRS Class 10 Ch. 661, Ant Internal

Area Scan (81x151x1): Measurement grid: dx=15mm, dy=15mm
Zoom Scan (5x5x7)/Cube 0: Measurement grid: dx=8mm, dy=8mm, dz=5mm
Power Drift = -0.029 dB
Peak SAR (extrapolated) = 0.190 W/kg
SAR(1 g) = 0.117 mW/g; SAR(10 g) = 0.073 mW/g

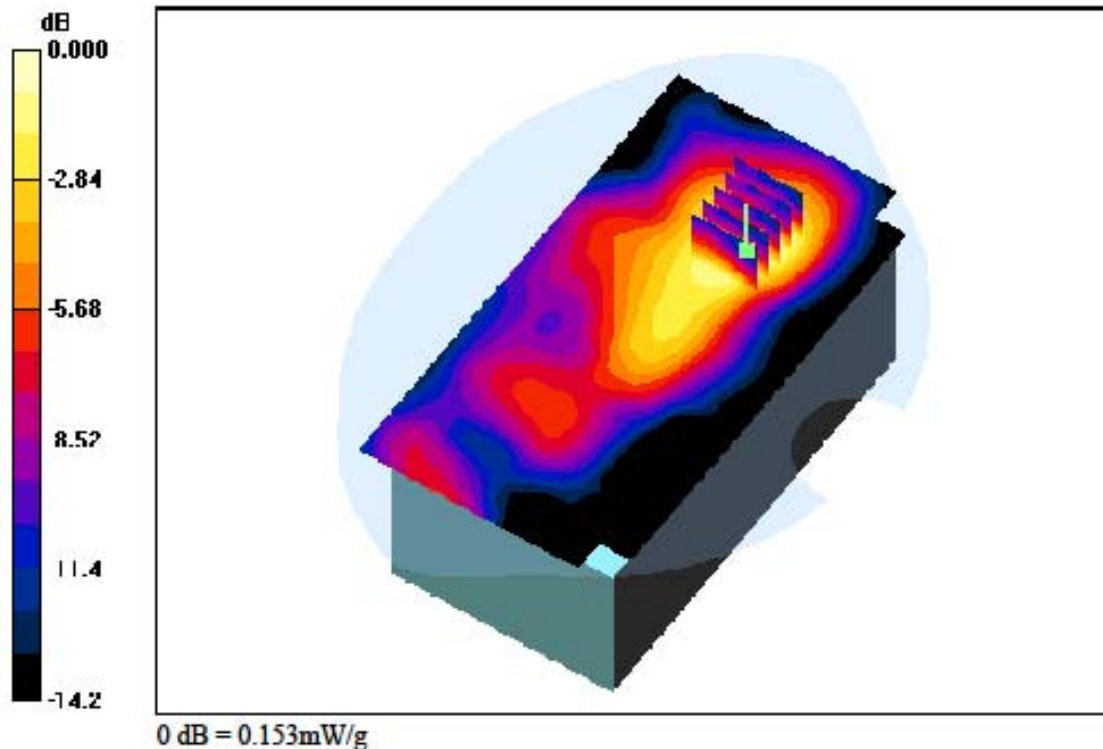

DIGITAL EMC CO., LTD**DUT: BIP-1530; Type: PDA**

Communication System: PCS1900; Frequency: 1880 MHz; Duty Cycle: 1:4.15
Medium parameters used: $f = 1880$ MHz; $\sigma = 1.5$ mho/m; $\epsilon_r = 52.4$; $\rho = 1000$ kg/m³
Phantom section: Flat Section

DASY4 Configuration:

Probe: EX3DV4 - SN3643; ConvF(7.34, 7.34, 7.34); Calibrated: 2012-01-27; Electronics: DAE3 Sn519
Phantom: SAM 1800/1900 MHz; Type: SAM; Serial: TP-1224
Measurement SW: DASY4, V4.7 Build 80; Postprocessing SW: SEMCAD, V1.8 Build 186

Test Date: 2012-08-28 Ambient Temp: 22.4; Tissue Temp: 22.6

Touch from Body, Finger Printer, Front, PCS1900 GPRS Class 10 Ch. 661, Ant Internal

Area Scan (81x151x1): Measurement grid: $dx=15$ mm, $dy=15$ mm
Zoom Scan (5x5x7)/Cube 0: Measurement grid: $dx=8$ mm, $dy=8$ mm, $dz=5$ mm
Power Drift = -0.015 dB
Peak SAR (extrapolated) = 0.166 W/kg
SAR(1 g) = 0.104 mW/g; SAR(10 g) = 0.066 mW/g

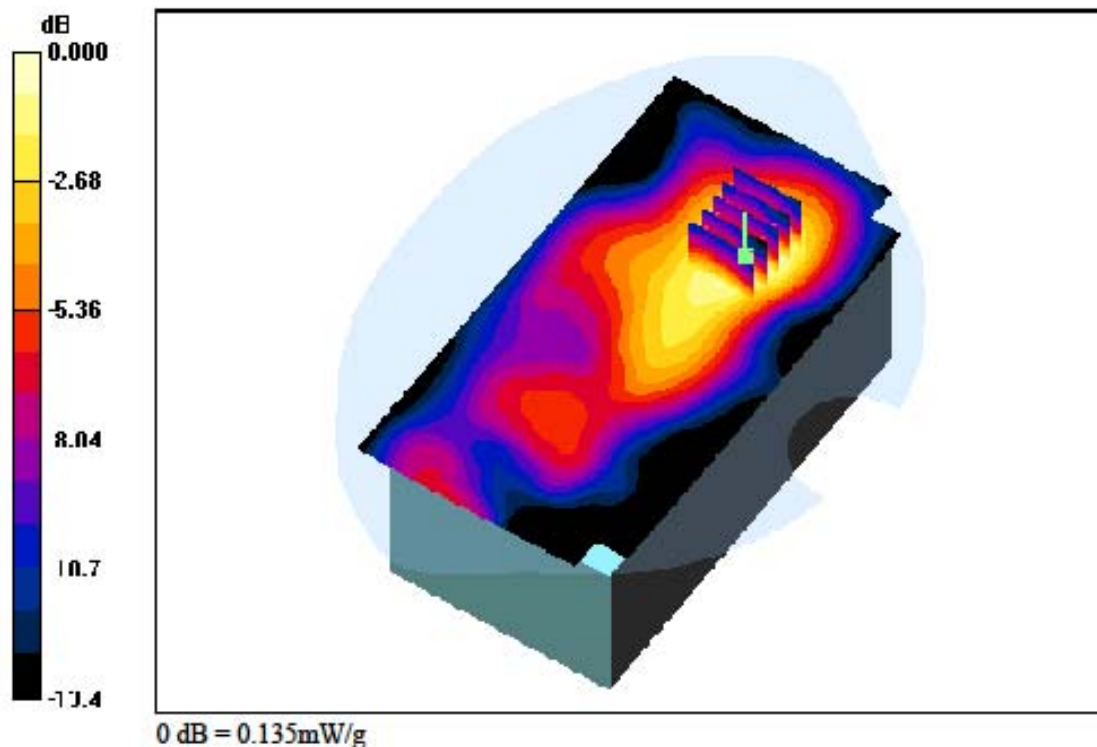

DIGITAL EMC CO., LTD**DUT: BIP-1530; Type: PDA**

Communication System: WCDMA 850 ; Frequency: 836.6 MHz; Duty Cycle: 1:1
Medium parameters used: $f = 836.6 \text{ MHz}$; $\sigma = 0.971 \text{ mho/m}$; $\epsilon_r = 53.7$; $\rho = 1000 \text{ kg/m}^3$
Phantom section: Flat Section

DASY4 Configuration:

Probe: EX3DV4 - SN3643; ConvF(9.12, 9.12, 9.12); Calibrated: 2012-01-27; Electronics: DAE3 Sn519
Phantom: SAM with 835MHz; Type: SAM; Serial: TP-1223
Measurement SW: DASY4, V4.7 Build 80; Postprocessing SW: SEMCAD, V1.8 Build 186

Test Date: 2012-08-31 Ambient Temp: 22.3; Tissue Temp: 22.6

Touch from Body, Front, WCDMA850 Ch. 4183, Ant Internal

Area Scan (81x161x1): Measurement grid: $dx=15\text{mm}$, $dy=15\text{mm}$
Zoom Scan (5x5x7)/Cube 0: Measurement grid: $dx=8\text{mm}$, $dy=8\text{mm}$, $dz=5\text{mm}$
Power Drift = -0.086 dB
Peak SAR (extrapolated) = 0.281 W/kg
SAR(1 g) = 0.200 mW/g; SAR(10 g) = 0.135 mW/g

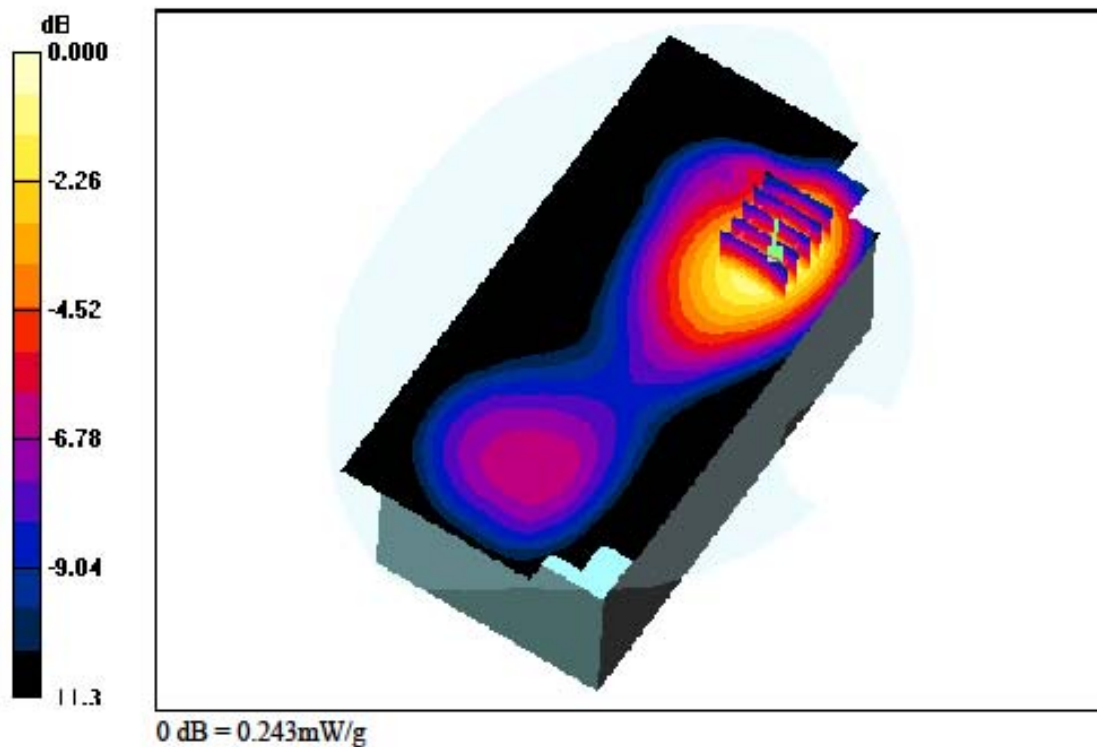

DIGITAL EMC CO., LTD**DUT: BIP-1530; Type: PDA**

Communication System: WCDMA 850 ; Frequency: 836.6 MHz; Duty Cycle: 1:1
Medium parameters used: $f = 836.6 \text{ MHz}$; $\sigma = 0.971 \text{ mho/m}$; $\epsilon_r = 53.7$; $\rho = 1000 \text{ kg/m}^3$

Phantom section: Flat Section

DASY4 Configuration:

Probe: EX3DV4 - SN3643; ConvF(9.12, 9.12, 9.12); Calibrated: 2012-01-27; Electronics: DAE3 Sn519

Phantom: SAM with 835MHz; Type: SAM; Serial: TP-1223

Measurement SW: DASY4, V4.7 Build 80; Postprocessing SW: SEMCAD, V1.8 Build 186

Test Date: 2012-08-31 Ambient Temp: 22.3; Tissue Temp: 22.6

Touch from Body, Rear, WCDMA850 Ch. 4183, Ant InternalArea Scan (81x161x1): Measurement grid: $dx=15\text{mm}$, $dy=15\text{mm}$ Zoom Scan (5x5x7)/Cube 0: Measurement grid: $dx=8\text{mm}$, $dy=8\text{mm}$, $dz=5\text{mm}$

Power Drift = 0.183 dB

Peak SAR (extrapolated) = 0.036 W/kg

SAR(1 g) = 0.027 mW/g; SAR(10 g) = 0.021 mW/g

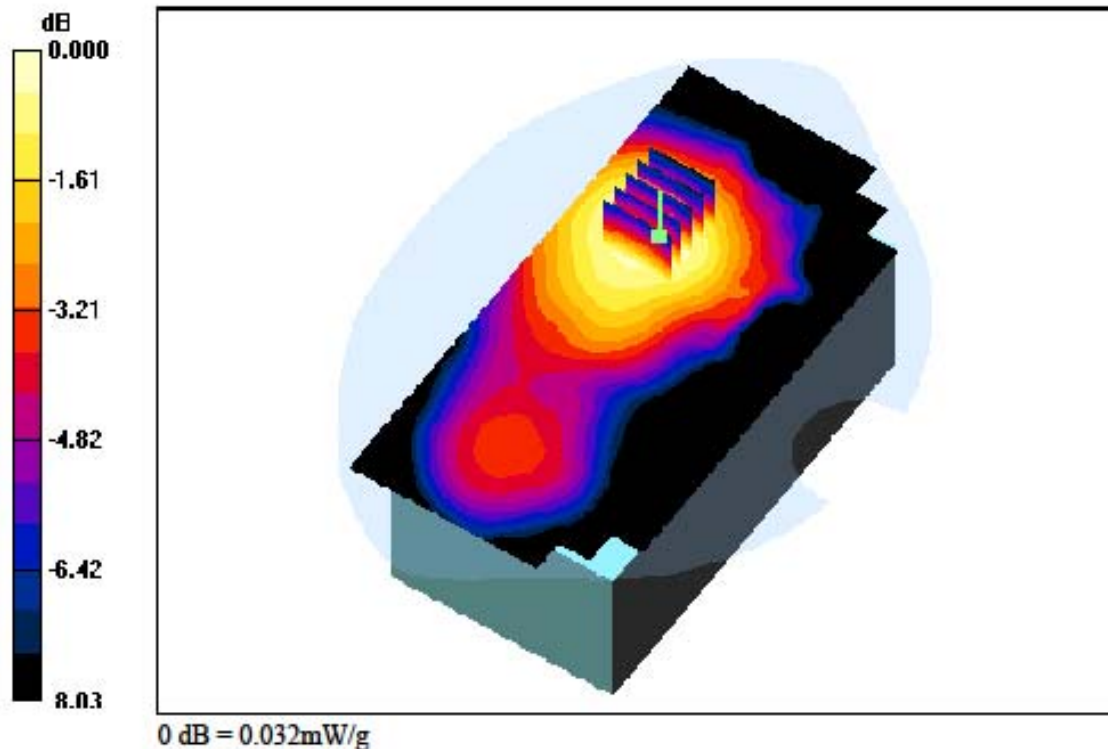

DIGITAL EMC CO., LTD**DUT: BIP-1530; Type: PDA**

Communication System: WCDMA 850 ; Frequency: 836.6 MHz; Duty Cycle: 1:1
Medium parameters used: $f = 836.6 \text{ MHz}$; $\sigma = 0.971 \text{ mho/m}$; $\epsilon_r = 53.7$; $\rho = 1000 \text{ kg/m}^3$
Phantom section: Flat Section

DASY4 Configuration:

Probe: EX3DV4 - SN3643; ConvF(9.12, 9.12, 9.12); Calibrated: 2012-01-27; Electronics: DAE3 Sn519
Phantom: SAM with 835MHz; Type: SAM; Serial: TP-1223
Measurement SW: DASY4, V4.7 Build 80; Postprocessing SW: SEMCAD, V1.8 Build 186

Test Date: 2012-08-31 Ambient Temp: 22.3; Tissue Temp: 22.6

Touch from Body, Sim2, Front, WCDMA850 Ch. 4183, Ant Internal

Area Scan (81x161x1): Measurement grid: $dx=15\text{mm}$, $dy=15\text{mm}$
Zoom Scan (5x5x7)/Cube 0: Measurement grid: $dx=8\text{mm}$, $dy=8\text{mm}$, $dz=5\text{mm}$
Power Drift = 0.033 dB
Peak SAR (extrapolated) = 0.276 W/kg
SAR(1 g) = 0.197 mW/g; SAR(10 g) = 0.134 mW/g

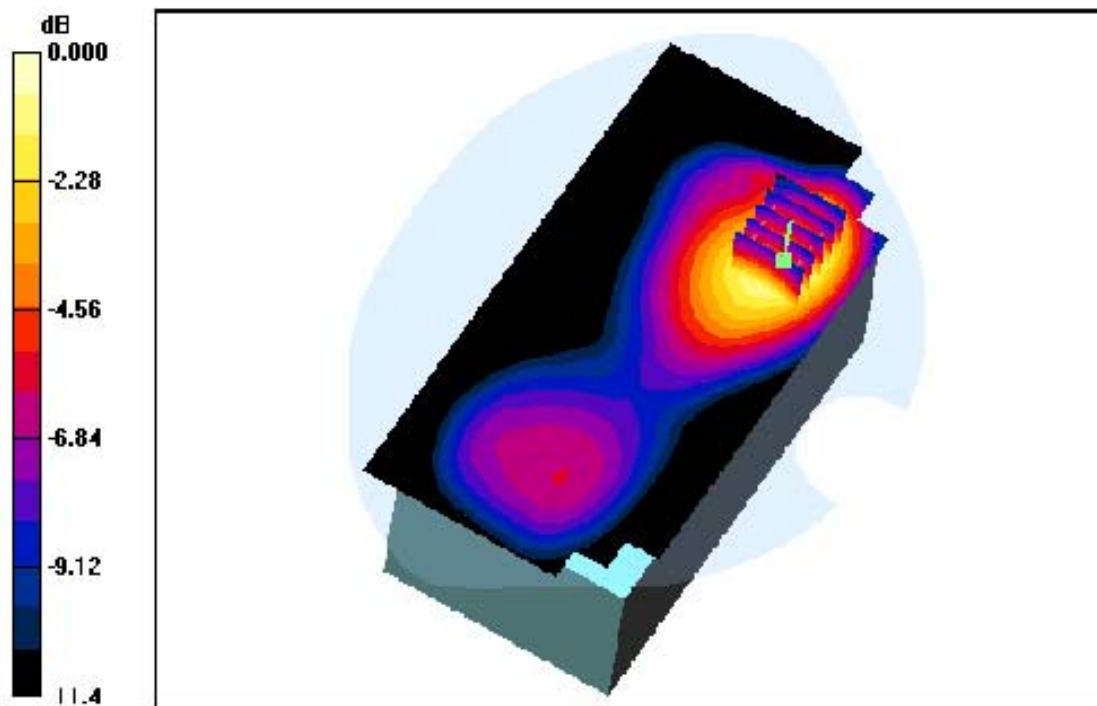

DIGITAL EMC CO., LTD**DUT: BIP-1530; Type: PDA**

Communication System: WCDMA 850 ; Frequency: 836.6 MHz; Duty Cycle: 1:1
Medium parameters used: $f = 836.6 \text{ MHz}$; $\sigma = 0.971 \text{ mho/m}$; $\epsilon_r = 53.7$; $\rho = 1000 \text{ kg/m}^3$
Phantom section: Flat Section

DASY4 Configuration:

Probe: EX3DV4 - SN3643; ConvF(9.12, 9.12, 9.12); Calibrated: 2012-01-27; Electronics: DAE3 Sn519
Phantom: SAM with 835MHz; Type: SAM; Serial: TP-1223
Measurement SW: DASY4, V4.7 Build 80; Postprocessing SW: SEMCAD, V1.8 Build 186

Test Date: 2012-08-31 Ambient Temp: 22.3; Tissue Temp: 22.6

Touch from Body, RFID, Front, WCDMA850 Ch. 4183, Ant Internal

Area Scan (81x161x1): Measurement grid: $dx=15\text{mm}$, $dy=15\text{mm}$
Zoom Scan (5x5x7)/Cube 0: Measurement grid: $dx=8\text{mm}$, $dy=8\text{mm}$, $dz=5\text{mm}$
Power Drift = 0.013 dB
Peak SAR (extrapolated) = 0.269 W/kg
SAR(1 g) = 0.194 mW/g; SAR(10 g) = 0.136 mW/g

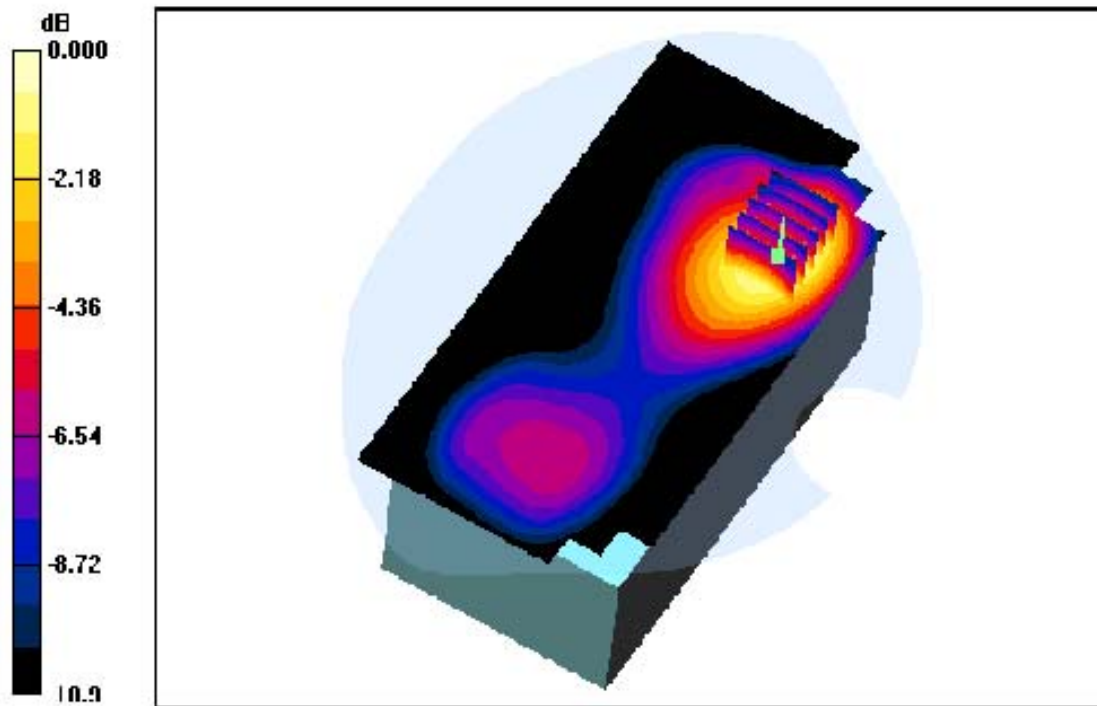

DIGITAL EMC CO., LTD**DUT: BIP-1530; Type: PDA**

Communication System: WCDMA 850 ; Frequency: 836.6 MHz; Duty Cycle: 1:1
 Medium parameters used: $f = 836.6 \text{ MHz}$; $\sigma = 0.971 \text{ mho/m}$; $\epsilon_r = 53.7$; $\rho = 1000 \text{ kg/m}^3$
 Phantom section: Flat Section

DASY4 Configuration:

Probe: EX3DV4 - SN3643; ConvF(9.12, 9.12, 9.12); Calibrated: 2012-01-27; Electronics: DAE3 Sn519
 Phantom: SAM with 835MHz; Type: SAM; Serial: TP-1223
 Measurement SW: DASY4, V4.7 Build 80; Postprocessing SW: SEMCAD, V1.8 Build 186

Test Date: 2012-08-31 Ambient Temp: 22.3; Tissue Temp: 22.6

Touch from Body, Card Reader, Front, WCDMA850 Ch. 4183, Ant Internal

Area Scan (81x161x1): Measurement grid: $dx=15\text{mm}$, $dy=15\text{mm}$
Zoom Scan (5x5x7)/Cube 0: Measurement grid: $dx=8\text{mm}$, $dy=8\text{mm}$, $dz=5\text{mm}$
 Power Drift = 0.175 dB
 Peak SAR (extrapolated) = 0.273 W/kg
 SAR(1 g) = 0.194 mW/g; SAR(10 g) = 0.132 mW/g

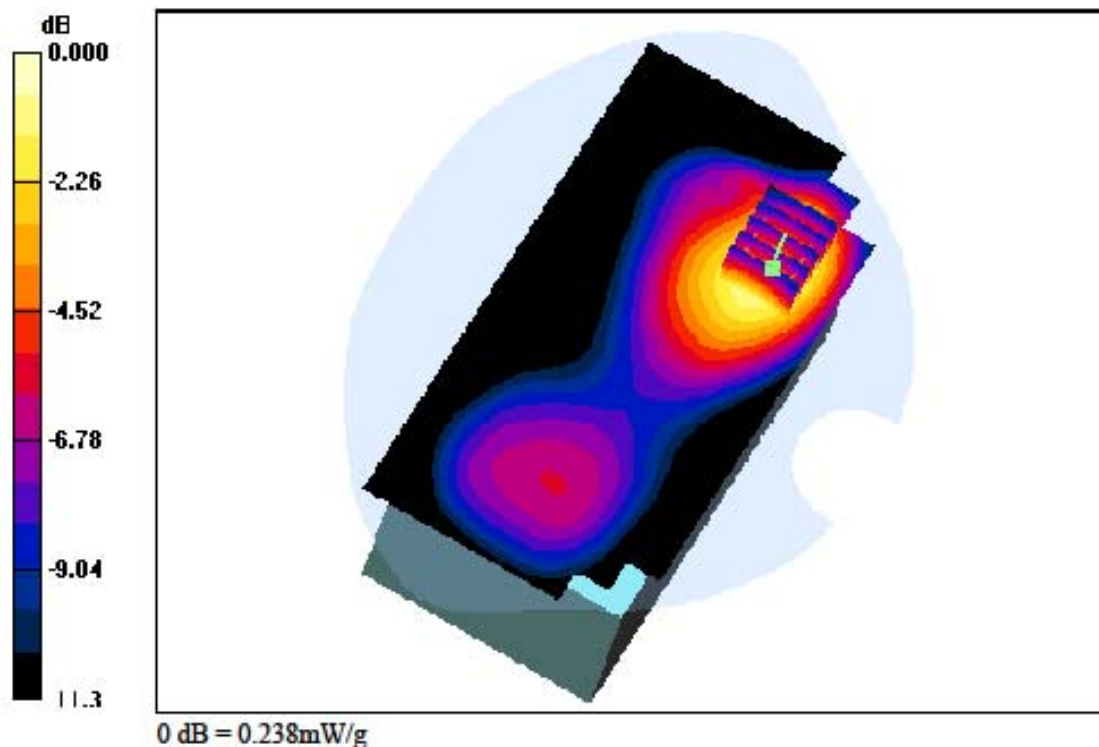

DIGITAL EMC CO., LTD

DUT: BIP-1530; Type: PDA

Communication System: WCDMA 850 ; Frequency: 836.6 MHz; Duty Cycle: 1:1
Medium parameters used: $f = 836.6 \text{ MHz}$; $\sigma = 0.971 \text{ mho/m}$; $\epsilon_r = 53.7$; $\rho = 1000 \text{ kg/m}^3$
Phantom section: Flat Section

DASY4 Configuration:

Probe: EX3DV4 - SN3643; ConvF(9.12, 9.12, 9.12); Calibrated: 2012-01-27; Electronics: DAE3 Sn519
Phantom: SAM with 835MHz; Type: SAM; Serial: TP-1223
Measurement SW: DASY4, V4.7 Build 80; Postprocessing SW: SEMCAD, V1.8 Build 186

Test Date: 2012-08-31 Ambient Temp: 22.3; Tissue Temp: 22.6

Touch from Body, Finger Printer, Front, WCDMA850 Ch. 4183, Ant Internal

Area Scan (81x161x1): Measurement grid: $dx=15\text{mm}$, $dy=15\text{mm}$
Zoom Scan (5x5x7)/Cube 0: Measurement grid: $dx=8\text{mm}$, $dy=8\text{mm}$, $dz=5\text{mm}$
Power Drift = -0.069 dB
Peak SAR (extrapolated) = 0.265 W/kg
SAR(1 g) = 0.190 mW/g; SAR(10 g) = 0.130 mW/g

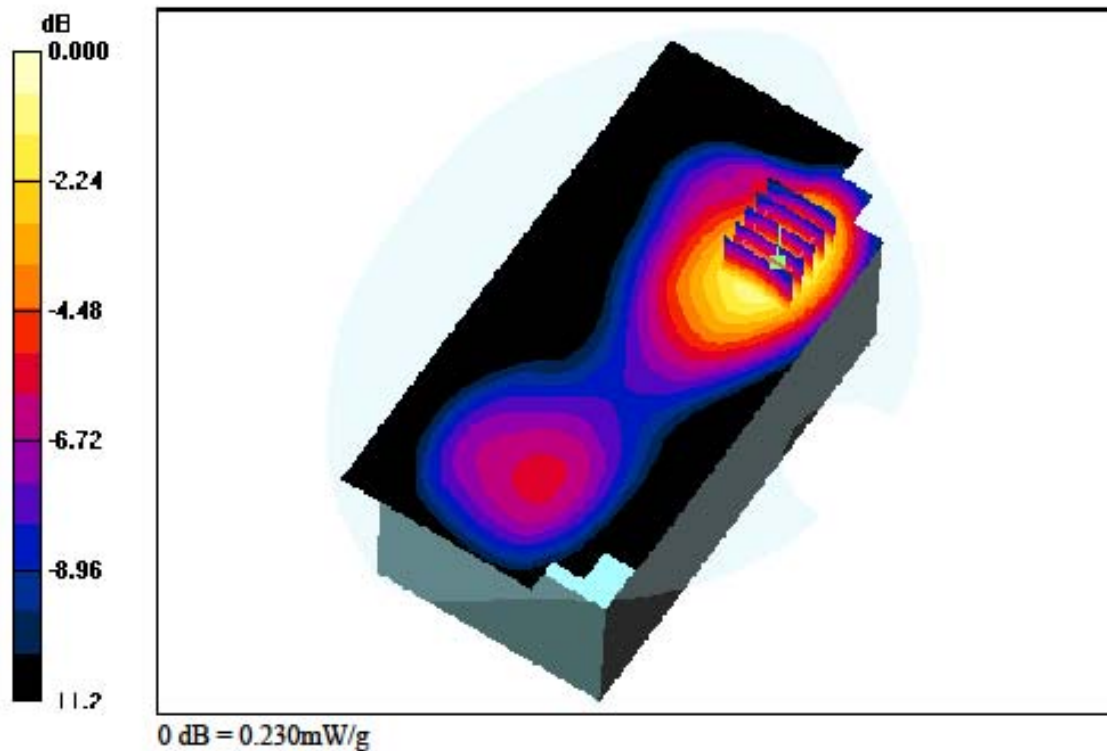

DIGITAL EMC CO., LTD

DUT: BIP-1530; Type: PDA

Communication System: WCDMA 1900; Frequency: 1880 MHz; Duty Cycle: 1:1
Medium parameters used: $f = 1880$ MHz; $\sigma = 1.51$ mho/m; $\epsilon_r = 52.3$; $\rho = 1000$ kg/m³
Phantom section: Flat Section

DASY4 Configuration:

Probe: EX3DV4 - SN3643; ConvF(7.34, 7.34, 7.34); Calibrated: 2012-01-27; Electronics: DAE3 Sn519
Phantom: SAM 1800/1900 MHz; Type: SAM; Serial: TP-1224
Measurement SW: DASY4, V4.7 Build 80; Postprocessing SW: SEMCAD, V1.8 Build 186

Test Date: 2012-09-01 Ambient Temp: 22.1; Tissue Temp: 22.2

Touch from Body, Front, WCDMA1900 Ch. 9400, Ant Internal

Area Scan (101x161x1): Measurement grid: dx=15mm, dy=15mm
Zoom Scan (5x5x7)/Cube 0: Measurement grid: dx=8mm, dy=8mm, dz=5mm
Power Drift = 0.017 dB
Peak SAR (extrapolated) = 0.349 W/kg
SAR(1 g) = 0.207 mW/g; SAR(10 g) = 0.126 mW/g

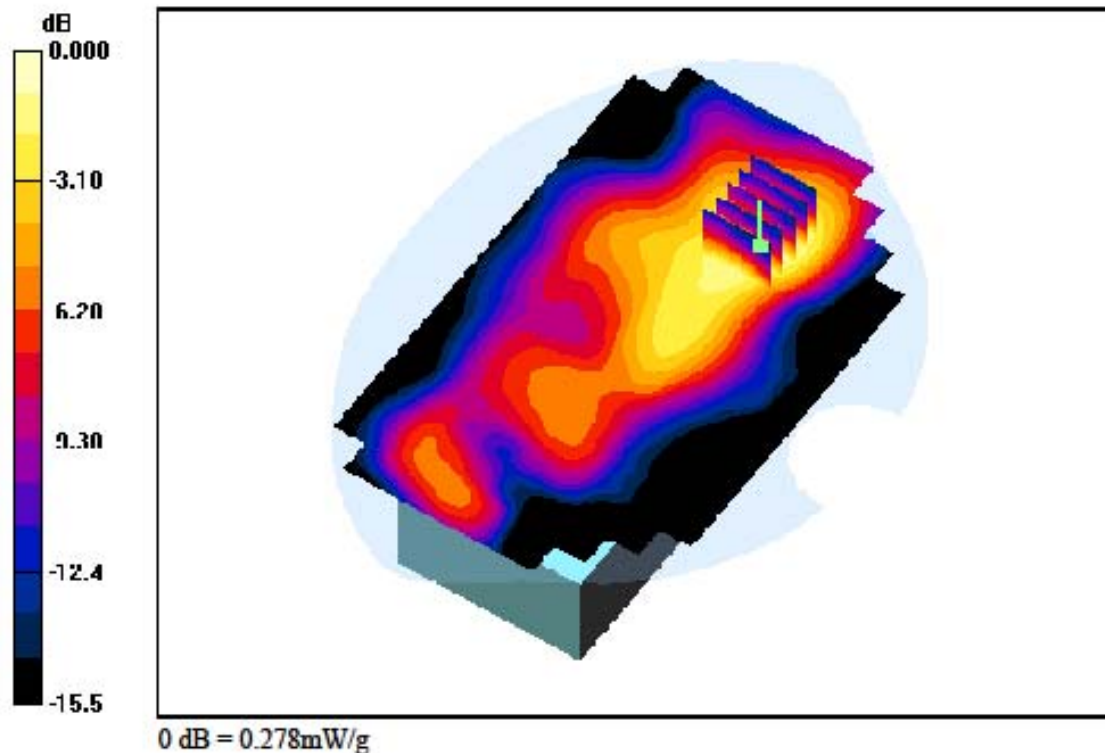

DIGITAL EMC CO., LTD**DUT: BIP-1530; Type: PDA**

Communication System: WCDMA 1900; Frequency: 1880 MHz; Duty Cycle: 1:1
Medium parameters used: $f = 1880$ MHz; $\sigma = 1.51$ mho/m; $\epsilon_r = 52.3$; $\rho = 1000$ kg/m³
Phantom section: Flat Section

DASY4 Configuration:

Probe: EX3DV4 - SN3643; ConvF(7.34, 7.34, 7.34); Calibrated: 2012-01-27; Electronics: DAE3 Sn519
Phantom: SAM 1800/1900 MHz; Type: SAM; Serial: TP-1224
Measurement SW: DASY4, V4.7 Build 80; Postprocessing SW: SEMCAD, V1.8 Build 186

Test Date: 2012-09-01 Ambient Temp: 22.1; Tissue Temp: 22.2

Touch from Body, Rear, WCDMA1900 Ch. 9400, Ant Internal

Area Scan (101x161x1): Measurement grid: dx=15mm, dy=15mm
Zoom Scan (5x5x7)/Cube 0: Measurement grid: dx=8mm, dy=8mm, dz=5mm
Power Drift = 0.086 dB
Peak SAR (extrapolated) = 0.112 W/kg
SAR(1 g) = 0.071 mW/g; SAR(10 g) = 0.044 mW/g

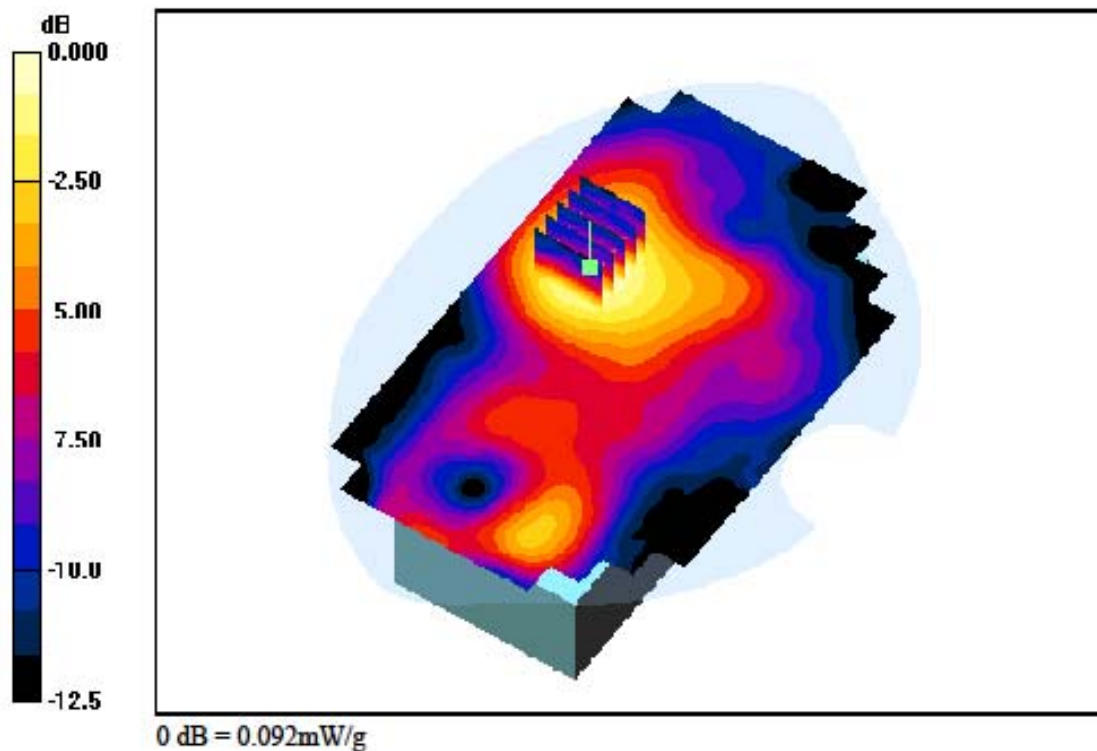

DIGITAL EMC CO., LTD**DUT: BIP-1530; Type: PDA**

Communication System: WCDMA 1900; Frequency: 1880 MHz; Duty Cycle: 1:1
Medium parameters used: $f = 1880$ MHz; $\sigma = 1.51$ mho/m; $\epsilon_r = 52.3$; $\rho = 1000$ kg/m³
Phantom section: Flat Section

DASY4 Configuration:

Probe: EX3DV4 - SN3643; ConvF(7.34, 7.34, 7.34); Calibrated: 2012-01-27; Electronics: DAE3 Sn519
Phantom: SAM 1800/1900 MHz; Type: SAM; Serial: TP-1224
Measurement SW: DASY4, V4.7 Build 80; Postprocessing SW: SEMCAD, V1.8 Build 186

Test Date: 2012-09-01 Ambient Temp: 22.1; Tissue Temp: 22.2

Touch from Body, Sim2, Front, WCDMA1900 Ch. 9400, Ant Internal

Area Scan (101x161x1): Measurement grid: dx=15mm, dy=15mm
Zoom Scan (5x5x7)/Cube 0: Measurement grid: dx=8mm, dy=8mm, dz=5mm
Power Drift = 0.044 dB
Peak SAR (extrapolated) = 0.346 W/kg
SAR(1 g) = 0.207 mW/g; SAR(10 g) = 0.126 mW/g

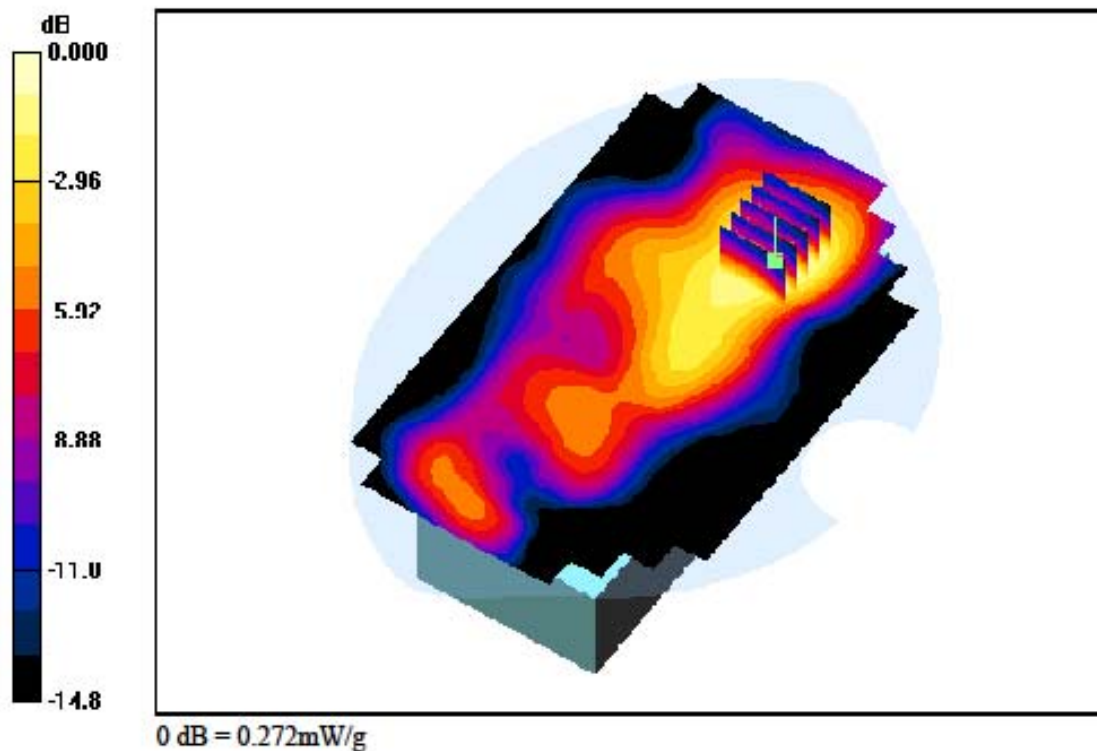

DIGITAL EMC CO., LTD**DUT: BIP-1530; Type: PDA**

Communication System: WCDMA 1900; Frequency: 1880 MHz; Duty Cycle: 1:1
Medium parameters used: $f = 1880$ MHz; $\sigma = 1.51$ mho/m; $\epsilon_r = 52.3$; $\rho = 1000$ kg/m³
Phantom section: Flat Section

DASY4 Configuration:

Probe: EX3DV4 - SN3643; ConvF(7.34, 7.34, 7.34); Calibrated: 2012-01-27; Electronics: DAE3 Sn519
Phantom: SAM 1800/1900 MHz; Type: SAM; Serial: TP-1224
Measurement SW: DASY4, V4.7 Build 80; Postprocessing SW: SEMCAD, V1.8 Build 186

Test Date: 2012-09-01 Ambient Temp: 22.1; Tissue Temp: 22.2

Touch from Body, RFID, Front, WCDMA1900 Ch. 9400, Ant Internal

Area Scan (101x161x1): Measurement grid: dx=15mm, dy=15mm
Zoom Scan (5x5x7)/Cube 0: Measurement grid: dx=8mm, dy=8mm, dz=5mm
Power Drift = 0.110 dB
Peak SAR (extrapolated) = 0.343 W/kg
SAR(1 g) = 0.203 mW/g; SAR(10 g) = 0.123 mW/g

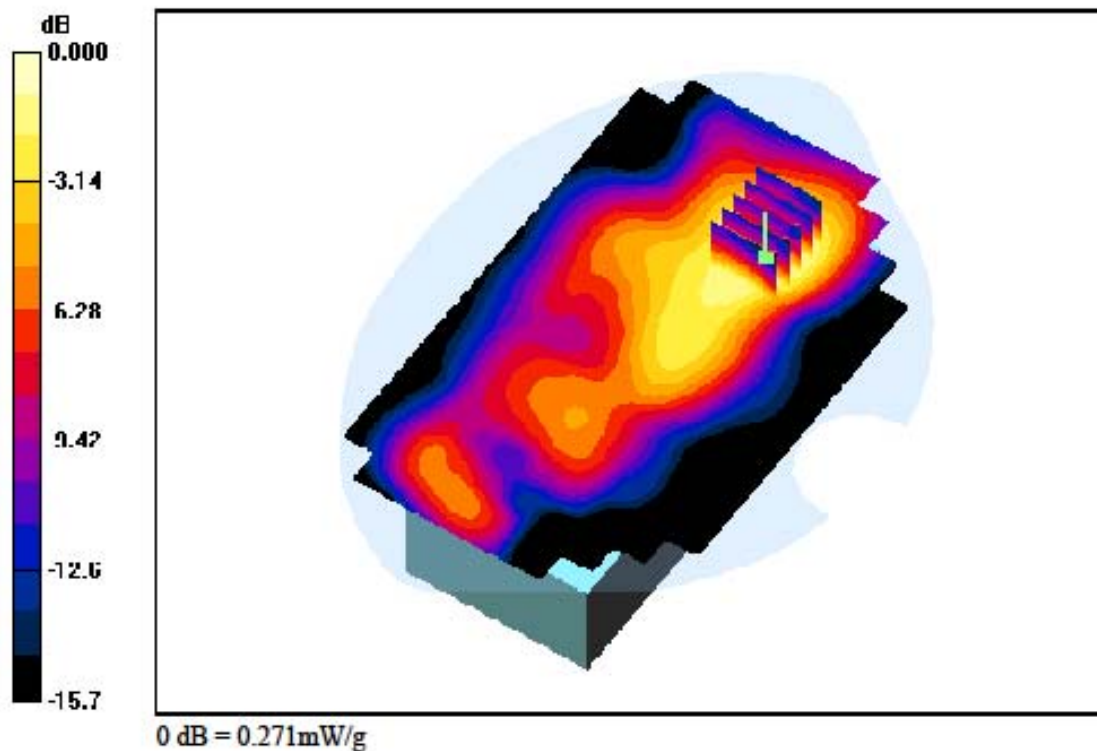

DIGITAL EMC CO., LTD**DUT: BIP-1530; Type: PDA**

Communication System: WCDMA 1900; Frequency: 1880 MHz; Duty Cycle: 1:1
Medium parameters used: $f = 1880$ MHz; $\sigma = 1.51$ mho/m; $\epsilon_r = 52.3$; $\rho = 1000$ kg/m³
Phantom section: Flat Section

DASY4 Configuration:

Probe: EX3DV4 - SN3643; ConvF(7.34, 7.34, 7.34); Calibrated: 2012-01-27; Electronics: DAE3 Sn519
Phantom: SAM 1800/1900 MHz; Type: SAM; Serial: TP-1224
Measurement SW: DASY4, V4.7 Build 80; Postprocessing SW: SEMCAD, V1.8 Build 186

Test Date: 2012-09-01 Ambient Temp: 22.1; Tissue Temp: 22.2

Touch from Body, Card Reader, Front, WCDMA1900 Ch. 9400, Ant Internal

Area Scan (101x161x1): Measurement grid: dx=15mm, dy=15mm
Zoom Scan (5x5x7)/Cube 0: Measurement grid: dx=8mm, dy=8mm, dz=5mm
Power Drift = 0.037 dB
Peak SAR (extrapolated) = 0.345 W/kg
SAR(1 g) = 0.206 mW/g; SAR(10 g) = 0.125 mW/g

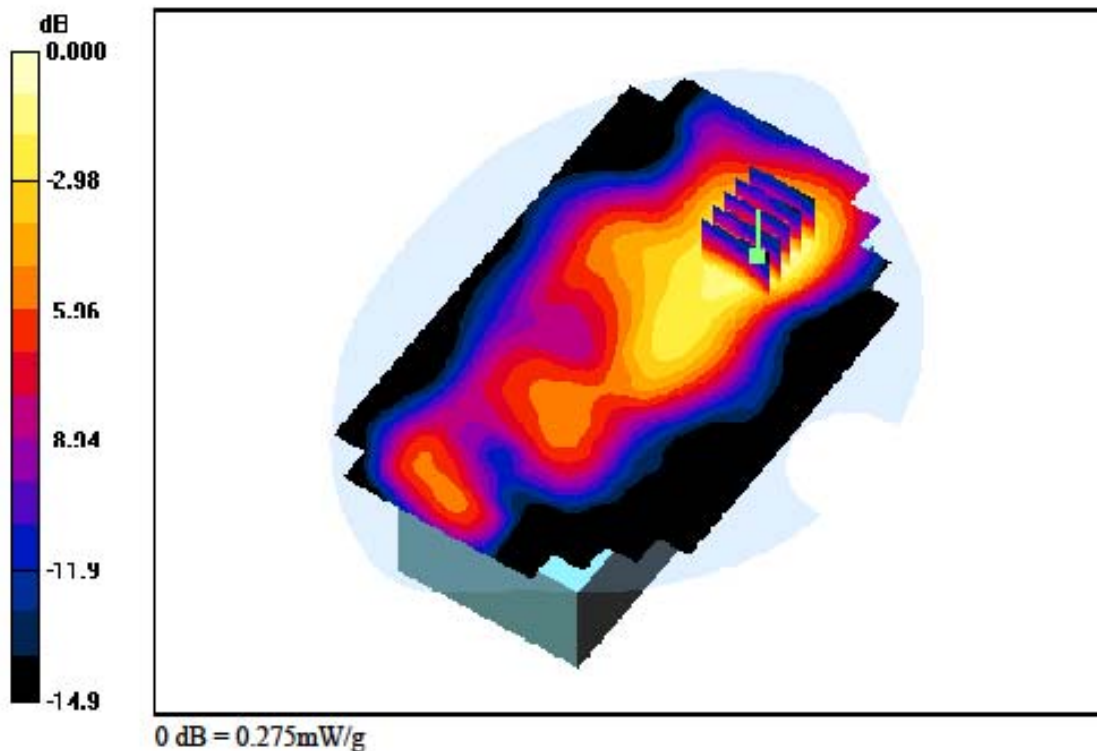

DIGITAL EMC CO., LTD

DUT: BIP-1530; Type: PDA

Communication System: WCDMA 1900; Frequency: 1880 MHz; Duty Cycle: 1:1
Medium parameters used: $f = 1880$ MHz; $\sigma = 1.51$ mho/m; $\epsilon_r = 52.3$; $\rho = 1000$ kg/m³
Phantom section: Flat Section

DASY4 Configuration:

Probe: EX3DV4 - SN3643; ConvF(7.34, 7.34, 7.34); Calibrated: 2012-01-27; Electronics: DAE3 Sn519
Phantom: SAM 1800/1900 MHz; Type: SAM; Serial: TP-1224
Measurement SW: DASY4, V4.7 Build 80; Postprocessing SW: SEMCAD, V1.8 Build 186

Test Date: 2012-09-01 Ambient Temp: 22.1; Tissue Temp: 22.2

Touch from Body, Finger Printer, Front, WCDMA1900 Ch. 9400, Ant Internal

Area Scan (101x161x1): Measurement grid: dx=15mm, dy=15mm
Zoom Scan (5x5x7)/Cube 0: Measurement grid: dx=8mm, dy=8mm, dz=5mm
Power Drift = -0.010 dB
Peak SAR (extrapolated) = 0.339 W/kg
SAR(1 g) = 0.205 mW/g; SAR(10 g) = 0.125 mW/g

