

RF TEST REPORT

Test item : Cradle
Model No. : 1SC-MT
Order No. : DEMC1208-01646
Date of receipt : 2012-08-30
Test duration : 2012-10-12 ~ 2013-01-14
Date of issue : 2013-03-05
Use of report : FCC Original Grant

Applicant : Bluebird Soft Inc.
1242, Gaepo-dong ,Gangnam-gu, Seoul, Korea

Test laboratory : Digital EMC Co., Ltd.
683-3, Yubang-Dong, Cheoin-Gu, Yongin-Si, Kyunggi-Do, 449-080, Korea

Test specification : FCC Part 15 Subpart C 247
Test environment : See appended test report
Test result : Pass Fail

The test results presented in this test report are limited only to the sample supplied by applicant and the use of this test report is inhibited other than its purpose. This test report shall not be reproduced except in full, without the written approval of DIGITAL EMC CO., LTD.

Tested by:

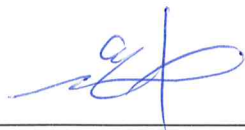

Engineer
HongHee Lee

Witnessed by:

N/A

Reviewed by:

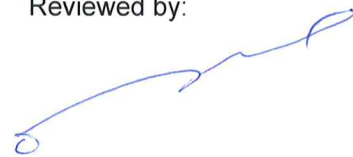

Deputy General Manager
WonJung Lee

Test Report Version

Test Report No.	Date	Description
DRTFCC1303-0200	Mar. 05, 2013	Final version for approval

Table of Contents

1. General Information	5
1.1 Testing Laboratory	5
1.2 Details of Applicant	5
1.3 Description of EUT	5
1.4 Declaration by the manufacturer	5
1.5 Information about the FHSS characteristics:	6
1.6 Test Equipment List	7
1.7 Summary of Test Results.....	8
1.8 Conclusion of worst-case and operation mode	9
2. Transmitter Radiated Spurious Emissions and Conducted Spurious Emission	10
2.1. Test Setup.....	10
2.2. Limit	10
2.3. Test Procedures	11
2.3.1. Test Procedures for Radiated Spurious Emissions.....	11
2.3.2. Test Procedures for Conducted Spurious Emissions	11
2.4. Test Results.....	12
2.4.1. Radiated Emission.....	12
2.4.2. Conducted Spurious Emissions	15
3. Carrier Frequency Separation.....	33
3.1. Test Setup.....	33
3.2. Limit	33
4. Number of Hopping Frequencies	38
4.1. Test Setup.....	38
4.2. Limit	38
5. 20dBc BW.....	47
5.1. Test Setup.....	47
5.2. Limit	47
5.3. Test Procedure	47
5.4. Test Results.....	47
6. Time of Occupancy (Dwell Time).....	53
6.1. Test Setup.....	53
6.2. Limit	53
6.3. Test Procedure	53
6.4. Test Results.....	53
7. Maximum Peak Output Power Measurement	58
7.1. Test Setup.....	58
7.2. Limit	58
7.3. Test Procedure.....	58
7.4. Test Results.....	58
8. Transmitter AC Power Line Conducted Emission	64

8.1. Test Setup..... 64
8.2. Limit 64
8.3. Test Procedures..... 64
8.4. Test Results..... 65
9. Antenna Requirement 67
9.1 Procedure 67
9.2 Conclusion 67
9.3 Minimum Standard 67
APPENDIX I 68

1. General Information

1.1 Testing Laboratory

Digital EMC Co., Ltd.

683-3, Yubang-Dong, Cheoin-Gu, Yongin-Si, Kyunggi-Do, 449-080, Korea

www.digitalemcc.com

Telephone : + 82-31-321-2664

FAX : + 82-31-321-1664

1.2 Details of Applicant

Applicant : Bluebird Soft Inc.

Address : 1242, Gaepo-dong ,Gangnam-gu, Seoul, Korea

Contact person : JooHyungLee

Phone No. : 070-7730-8239

1.3 Description of EUT

Product	Cradle
Model Name	1SC-MT
Serial Number	Identical prototype
Power Supply	DC 9V
Frequency Range	2402 ~ 2480MHz
Modulation Technique	GFSK, $\pi/4$ -DQPSK, 8DPSK
Number of Channels	79
Antenna Type	CHIP Antenna
Antenna Gain	PK :1.40dBi

1.4. Declaration by the manufacturer

- N/A

1.5. Information about the FHSS characteristics:

- This Bluetooth module has been tested by a Bluetooth Qualification Lab, and we confirm the following:
 - A) The hopping sequence is pseudorandom
 - B) All channels are used equally on average
 - C) The receiver input bandwidth equals the transmit bandwidth
 - D) The receiver hops in sequence with the transmit signal
- 15.247(g): In accordance with the Bluetooth Industry Standard, the system is designed to comply with all of the regulations in Section 15.247 when the transmitter is presented with a continuous data (or information) system.
- 15.247(h): In accordance with the Bluetooth Industry Standard, the system does not coordinate its channels selection/ hopping sequence with other frequency hopping systems for the express purpose of avoiding the simultaneous occupancy of individual hopping frequencies by multiple transmitter.
- 15.247(h): The EUT employs Adaptive Frequency Hopping (AFH) which identifies sources of interference namely devices operating in 802.11 WLAN and excludes them from the list of available channels. The process of re-mapping reduces the number of test channels from 79 channels to a minimum number of 20 channels.

1.6. Test Equipment List

Type	Manufacturer	Model	Cal.Date (yy/mm/dd)	Next.Cal.Date (yy/mm/dd)	S/N
Spectrum Analyzer	Agilent	E4440A	12/09/18	13/09/18	MY45304199
Spectrum Analyzer	Rohde Schwarz	FSQ26	12/02/06	13/02/06	200445
Digital Multimeter	H.P	34401A	12/03/05	13/03/05	3146A13475
Signal Generator	Rohde Schwarz	SMR20	12/03/05	13/03/05	101251
MXA Signal Analyzer	Agilent	N9020A	12/01/09	13/01/09	MY49100833
			13/01/08	14/01/08	
Vector Signal Generator	Rohde Schwarz	SMJ100A	12/01/09	13/01/09	100148
			13/01/08	14/01/08	
Thermo hygrometer	BODYCOM	BJ5478	12/06/20	13/06/20	120612-2
Bluetooth Tester	TESCOM	TC-3000B	12/07/01	13/07/01	3000B000268
Power Splitter	Anritsu	K241B	12/09/17	13/09/17	020611
DC Power Supply	HP	6622A	12/03/05	13/03/05	3448A03760
High-pass filter	Wainwright	WHNX3.0	12/09/17	13/09/17	9
LOOP Antenna	Schwarzbeck	FMZB1513	12/09/24	13/09/24	1513-128
BILOG ANTENNA	SCHAFFNER	CBL6112B	12/11/16	14/11/16	2737
HORN ANT	ETS	3115	12/02/20	14/02/20	6419
HORN ANT	A.H.Systems	SAS-574	11/03/25	13/03/25	154
Amplifier (22dB)	H.P	8447E	12/01/09	13/01/09	2945A02865
			13/01/08	14/01/08	
Amplifier (30dB)	Agilent	8449B	12/03/05	13/03/05	3008A00370
EMI TEST RECEIVER	R&S	ESU	12/01/09	13/01/09	100014
			13/01/08	14/01/08	
EMI TEST RECEIVER	R&S	ESCI	12/03/06	13/03/06	100364
CVCF	KIKUSUI	PCR1000L	12/09/15	13/09/15	14110610
LISN	R&S	ESH2-Z5	12/09/18	13/09/18	828739/006
RFI/Field intensity Meter	KYORITSU	KNM-2402	12/07/02	13/07/02	4N-170-3

1.7. Summary of Test Results

FCC Part Section(s)	Parameter	Limit (Using in 2400~ 2483.5MHz)	Test Condition	Status Note 1
15.247(a)	Carrier frequency separation	>= 20dB BW or >= Two-Thirds of the 20dB BW	Conducted	C
	Number of hopping frequencies	>= 15 hops		C
	99% &20 dB bandwidth	None		C
	Dwell time	=< 0.4 seconds		C
15.247(b)	Transmitter output power	=< 1Watt , if CHs >= 75 Others =<0.125W		C
15.247(d)	Band-edge	The radiated emission to any 100 kHz of out-band shall be at least 20dB below the highest in-band spectral density.	C	
	Conducted spurious emissions		C	
15.247(d) 15.205 15.209	Radiated emissions	FCC 15.209 Limits	Radiated	C
15.207	AC conducted emissions	FCC 15.207 Limits	AC Line Conducted	C
15.203	Antenna requirements	FCC 15.203	-	C

Note 1: **C**=Comply **NC**=Not Comply **NT**=Not Tested **NA**=Not Applicable

Note 2:The sample was tested according to the following specification:
 ANSI C63.10-2009, DA00-705

1.8 Conclusion of worst-case and operation mode

The EUT has three type of modulation (GFSK, $\pi/4$ DQPSK and 8DPSK).

Therefore all applicable requirements were tested with all the modulations.

The field strength of spurious emissions was measured in three orthogonal EUT positions(X, Y and Z axis).

Tested frequency information,

- Hopping Function: Enable

	TXFrequency(MHz)	RX Frequency(MHz)
Hopping Band	2402 ~ 2480	2402 ~ 2480

- Hopping Function: Disable

	TXFrequency(MHz)	RX Frequency(MHz)
Lowest Channel	2402	2402
Middle Channel	2441	2441
Highest Channel	2480	2480

2. Transmitter Radiated Spurious Emissions and Conducted Spurious Emission

2.1. Test Setup

Refer to the APPENDIX I.

2.2. Limit

According to §15.247(d), in any 100 kHz bandwidth outside the frequency band in which the spread spectrum or digitally modulated intentional radiator is operating, the radio frequency power that is produced by the intentional radiator shall be at least 20 dB below that in the 100 kHz bandwidth within the band that contains the highest level of the desired power, based on either an RF conducted or a radiated measurement, provided the transmitter demonstrates compliance with the peak conducted power limits. If the transmitter complies with the conducted power limits based on the use of RMS averaging over a time interval, as permitted under paragraph(b)(3) of this section, the attenuation required under this paragraph shall be 30 dB instead of 20 dB. Attenuation below the general limits specified in section §15.209(a) is not required. In addition, radiated emission which in the restricted band, as define in section §15.205(a), must also comply the radiated emission limits specified in section §15.209(a) (see section §15.205(c))

According to § 15.209(a), except as provided elsewhere in this Subpart, the emissions from an intentional radiator shall not exceed the field strength levels specified in the following table

Frequency (MHz)	Limit (uV/m) @ 3m
30 ~ 88	100 **
88 ~ 216	150 **
216 ~ 960	200 **
Above 960	500

** Except as provided in 15.209(g), fundamental emissions from intentional radiators operating under this Section shall not be located in the frequency bands 54-72 MHz, 76-88MHz, 174-216MHz or 470-806MHz. However, operation within these frequency bands is permitted under other sections of this Part, e.g. 15.231 and 15.241.

According to § 15.205(a) and (b), only spurious emissions are permitted in any of the frequency bands listed below:

MHz	MHz	MHz	MHz	GHz	GHz
0.009 ~ 0.110	8.41425 ~ 8.41475	108 ~ 121.94	1300 ~ 1427	3600 ~ 4400	14.47 ~ 14.5
0.495 ~ 0.505	12.29 ~ 12.293	123 ~ 138	1435 ~ 1626.5	4.5 ~ 5.15	15.35 ~ 16.2
2.1735 ~ 2.1905	12.51975 ~ 12.52025	149.9 ~ 150.05	1645.5 ~ 1646.5	5.35 ~ 5.46	17.7 ~ 22.4
4.125 ~ 4.128	12.57675 ~ 12.57725	156.52475 ~	1660 ~ 1710	7.25 ~ 7.75	22.01 ~ 23.12
4.17725 ~ 4.17775	13.36 ~ 13.41	156.52525	1718.8 ~ 1722.2	8.025 ~ 8.5	23.6 ~ 24.0
4.20725 ~ 4.20775	16.42 ~ 16.423	156.7 ~ 156.9	2200 ~ 2300	9.0 ~ 9.2	31.2 ~ 31.8
6.215 ~ 6.218	16.69475 ~ 16.69525	162.0125 ~ 167.17	2310 ~ 2390	9.3 ~ 9.5	36.43 ~ 36.5
6.26775 ~ 6.26825	16.80425 ~ 16.80475	167.72 ~ 173.2	2483.5 ~ 2500	10.6 ~ 12.7	Above 38.6
6.31175 ~ 6.31225	25.5 ~ 25.67	240 ~ 285	2655 ~ 2900	13.25 ~ 13.4	
8.291 ~ 8.294	37.5 ~ 38.25	322 ~ 335.4	3260 ~ 3267		
8.362 ~ 8.366	73 ~ 74.6	399.90 ~ 410	3332 ~ 3339		
8.37625 ~ 8.38675	74.8 ~ 75.2	608 ~ 614	3345.8 ~ 3358		
		960 ~ 1240			

The field strength of emissions appearing within these frequency bands shall not exceed the limits shown in §15.209. At frequencies equal to or less than 1000 MHz, compliance with the limits in §15.209 shall be demonstrated using measurement instrumentation employing a CISPR quasi-peak detector. Above 1000 MHz, compliance with the emission limits in §15.209 shall be demonstrated based on the average value of the measured emissions. The provisions in §15.35 apply to these measurements.

2.3. Test Procedures

Radiated emissions from the EUT were measured according to the DA 00-705 and ANSI C63.10-2009

2.3.1. Test Procedures for Radiated Spurious Emissions

1. The EUT was placed on the top of a rotating table 0.8 meters above the ground at a 3 meter anechoic chamber test site. The table was rotated 360 degrees to determine the position of the highest radiation.
2. During performing radiated emission below 1 GHz, the EUT was set 3 meters away from the interference receiving antenna, which was mounted on the top of a variable-height antenna tower. During performing radiated emission above 1 GHz, the EUT was set 3 meter away from the interference-receiving antenna.
3. The antenna is a broadband antenna, and its height is varied from one meter to four meters above the ground to determine the maximum value of the field strength. Both horizontal and vertical polarizations of the antenna are set to make the measurement.
4. For each suspected emission, the EUT was arranged to its worst case and then the antenna was tuned to heights from 1 meter to 4 meters and the table was turned from 0 degrees to 360 degrees to find the maximum reading.
5. The test-receiver system was set to Peak Detect Function and Specified Bandwidth with Maximum Hold Mode.
6. If the emission level of the EUT in peak mode was 10 dB lower than the limit specified, then testing could be stopped and the peak values of the EUT would be reported. Otherwise the emissions that did not have 10 dB margin would be re-tested one by one using peak, quasi-peak or average method as specified and then reported in a data sheet.

Note : Measurement Instrument Setting for Radiated Emission Measurements.

1. Frequency Range Below 1 GHz

RBW = 100 or 120 KHz, VBW = 3 x RBW , Detector = Peak or Quasi Peak

2. Frequency Range > 1 GHz

Peak Measurement > 1 GHz

RBW = 1 MHz , VBW = 3 MHz, Detector = Peak

Average Measurement > 1GHz

VBW = 10 Hz, When duty cycle is no less than 98 percent.

VBW ≥ 1/T, when duty cycle is less than 98 percent where T is the minimum transmission duration over which the transmitter is on and is transmitting at its maximum power control level for the tested mode of operation.

Mode	Duty Cycle (%)	T _{on} (ms)	1/T _{on} (Hz)	Determined VBW Setting
BT	76.80	2.88	347	1 kHz

Note1: For average measurement with duty cycle < 98%, the reduced VBW measurement method of Section 4.2.3.2.3 in ANSI C63.10 is used.

Note2: If necessary, ANSI C63.10 Section 4.2.3.2.4 is applied for pulsed emissions as following description. Unless otherwise specified, when the radiated emission limits are expressed in terms of the average value of the emission, and pulsed operation is employed, the measurement field strength shall be determined by averaging over one complete pulse train, including blanking intervals, as long as the pulse train does not exceed 0.1 s. As an alternative (provided the unlicensed wireless device operates for longer than 0.1 s) or in cases where the pulse train exceeds 0.1 s, the measured field strength shall be determined from the average absolute voltage during a 0.1 second interval while the field strength is at its maximum value. Please see Note 4 of the radiated emission tables for calculation of Duty cycle Correction Factor (DCF).

2.3.2. Test Procedures for Conducted Spurious Emissions

1. The transmitter output was connected to the spectrum analyzer.
2. The reference level of the fundamental frequency was measured with the spectrum analyzer using RBW=100 kHz, VBW=300 kHz.
3. The conducted spurious emission was performed using the spectrum analyzer's spurious measurement function from 30 MHz to 25 GHz with the 11 sub measurement ranges.(Detail ranges are listed on the measurement plots) The following spectrum settings were used for each measurement rages.
 RBW=100 kHz, VBW=300 kHz, SWEEP TIME = AUTO, DETECTOR = PEAK, TRACE = MAX HOLD.

2.4. Test Results

Ambient temperature : 24°C
 Relative humidity : 49%

2.4.1. Radiated Emission

9KHz ~ 25GHz Data(Modulation: GFSK)

▪ Lowest Channel

Frequency (MHz)	ANT Pol	The worst case EUT Position (Axis)	Detector Mode	Reading (dBuV)	T.F (dB/m)	D.C.F. (dB)	Result (dBuV/m)	Limit (dBuV/m)	Margin (dB)
84.665	V	X	QP	51.47	-14.60	N/A	36.87	40.00	3.13
266.248	H	X	QP	49.10	-7.90	N/A	41.20	46.00	4.80
2388.640	V	X	PK	56.69	-4.73	N/A	51.96	74.00	22.04
2388.660	V	X	AV	48.59	-4.73	N/A	43.86	54.00	10.14
4803.640	V	X	PK	69.47	2.23	N/A	71.70	74.00	2.30
4803.640	V	X	AV	66.77	2.23	-30.81	38.19	54.00	15.81

▪ Middle Channel

Frequency (MHz)	ANT Pol	The worst case EUT Position (Axis)	Detector Mode	Reading (dBuV)	T.F (dB/m)	D.C.F. (dB)	Result (dBuV/m)	Limit (dBuV/m)	Margin (dB)
84.667	V	X	QP	50.97	-14.60	N/A	36.37	40.00	3.63
266.250	H	X	QP	48.66	-7.90	N/A	40.76	46.00	5.24
4882.300	V	X	PK	66.53	2.92	N/A	69.45	74.00	4.55
4882.300	V	X	AV	65.36	2.92	-30.81	37.47	54.00	16.53

▪ Highest Channel

Frequency (MHz)	ANT Pol	The worst case EUT Position (Axis)	Detector Mode	Reading (dBuV)	T.F (dB/m)	D.C.F. (dB)	Result (dBuV/m)	Limit (dBuV/m)	Margin (dB)
84.659	V	X	QP	51.46	-14.60	N/A	36.86	40.00	3.14
266.247	H	X	QP	48.73	-7.90	N/A	40.83	46.00	5.17
2483.560	V	X	PK	76.41	-4.66	N/A	71.75	74.00	2.25
2483.560	V	X	AV	67.70	-4.66	-30.81	32.23	54.00	21.77
4960.310	V	X	PK	67.19	2.67	N/A	69.86	74.00	4.14
4960.310	V	X	AV	66.20	2.67	-30.81	38.06	54.00	15.94

Note.

- No other spurious and harmonic emissions were reported greater than listed emissions above table.
- Above listed point data is the worst case data.
- Sample Calculation.
 $Margin = Limit - Result$ / $Result = Reading + T.F + D.C.F.$ / $T.F = AF + CL - AG$
 Where, T.F = Total Factor, AF = Antenna Factor, CL = Cable Loss, AG = Amplifier Gain,
- Duty Cycle Correction Factor
 - Time to cycle through all channels= $\Delta t = \tau_{[ms]} \times 79 \text{ channels} = 227.52ms$, where τ = pulse width
 - $100ms / \Delta t_{[ms]} = H$ -> Round up to next highest integer, to account for worst case, $H' = 1$
 - Worst Case Dwell Time = $\tau_{[ms]} \times H' = 2.88ms$
 - Duty Cycle Correction = $20\log(\text{Worst Case Dwell Time} / 100ms)_{[dB]} = -30.81 \text{ dB}$

9KHz ~ 25GHz Data(Modulation: $\pi/4$ -DQPSK)

▪ **Lowest Channel**

Frequency (MHz)	ANT Pol	The worst case EUT Position (Axis)	Detector Mode	Reading (dBuV)	T.F (dB/m)	D.C.F. (dB)	Result (dBuV/m)	Limit (dBuV/m)	Margin (dB)
84.645	V	X	QP	51.53	-14.60	N/A	36.93	40.00	3.07
266.241	H	X	QP	49.17	-7.90	N/A	41.27	46.00	4.73
2389.910	V	X	PK	55.15	-4.73	N/A	50.42	74.00	23.58
2389.910	V	X	AV	46.35	-4.73	N/A	41.62	54.00	12.38
4803.690	V	X	PK	67.80	2.23	N/A	70.03	74.00	3.97
4803.690	V	X	AV	63.02	2.23	-30.81	34.44	54.00	19.56

▪ **Middle Channel**

Frequency (MHz)	ANT Pol	The worst case EUT Position (Axis)	Detector Mode	Reading (dBuV)	T.F (dB/m)	D.C.F. (dB)	Result (dBuV/m)	Limit (dBuV/m)	Margin (dB)
84.647	V	X	QP	51.56	-14.60	N/A	36.96	40.00	3.04
266.266	H	X	QP	49.26	-7.90	N/A	41.36	46.00	4.64
4882.250	V	X	PK	66.25	2.92	N/A	69.17	74.00	4.83
4882.250	V	X	AV	61.26	2.92	-30.81	33.37	54.00	20.63

▪ **Highest Channel**

Frequency (MHz)	ANT Pol	The worst case EUT Position (Axis)	Detector Mode	Reading (dBuV)	T.F (dB/m)	D.C.F. (dB)	Result (dBuV/m)	Limit (dBuV/m)	Margin (dB)
84.636	V	X	QP	50.35	-14.60	N/A	35.75	40.00	4.25
266.275	H	X	QP	48.68	-7.90	N/A	40.78	46.00	5.22
2483.600	V	X	PK	75.13	-4.66	N/A	70.47	74.00	3.53
2483.600	V	X	AV	70.96	-4.66	-30.81	35.49	54.00	18.51
4960.270	V	X	PK	66.50	2.67	N/A	69.17	74.00	4.83
4960.270	V	X	AV	61.15	2.67	-30.81	33.01	54.00	20.99

Note.

- No other spurious and harmonic emissions were reported greater than listed emissions above table.
- Above listed point data is the worst case data.
- Sample Calculation.
 $Margin = Limit - Result$ / $Result = Reading + T.F + D.C.F.$ / $T.F = AF + CL - AG$
 Where, T.F = Total Factor, AF = Antenna Factor, CL = Cable Loss, AG = Amplifier Gain,
- Duty Cycle Correction Factor
 - Time to cycle through all channels= $\Delta t = \tau_{[ms]} \times 79 \text{ channels} = 227.52ms$, where τ = pulse width
 - $100ms / \Delta t_{[ms]} = H$ -> Round up to next highest integer, to account for worst case, $H' = 1$
 - Worst Case Dwell Time = $\tau_{[ms]} \times H' = 2.88ms$
 - Duty Cycle Correction = $20\log(\text{Worst Case Dwell Time} / 100ms)_{[dB]} = -30.81 \text{ dB}$

9KHz ~ 25GHz Data(Modulation: 8DPSK)

▪ **Lowest Channel**

Frequency (MHz)	ANT Pol	The worst case EUT Position (Axis)	Detector Mode	Reading (dBuV)	T.F (dB/m)	D.C.F. (dB)	Result (dBuV/m)	Limit (dBuV/m)	Margin (dB)
84.666	V	X	QP	51.28	-14.60	N/A	36.68	40.00	3.32
266.254	H	X	QP	48.99	-7.90	N/A	41.09	46.00	4.91
2388.080	V	X	PK	54.89	-4.73	N/A	50.16	74.00	23.84
2388.030	V	X	AV	46.54	-4.73	N/A	41.81	54.00	12.19
4804.060	V	X	PK	67.89	2.23	N/A	70.12	74.00	3.88
4804.060	V	X	AV	63.24	2.23	-30.81	34.66	54.00	19.34

▪ **Middle Channel**

Frequency (MHz)	ANT Pol	The worst case EUT Position (Axis)	Detector Mode	Reading (dBuV)	T.F (dB/m)	D.C.F. (dB)	Result (dBuV/m)	Limit (dBuV/m)	Margin (dB)
84.597	V	X	QP	51.09	-14.60	N/A	36.49	40.00	3.51
266.425	H	X	QP	49.35	-7.90	N/A	41.45	46.00	4.55
4882.000	V	X	PK	66.42	2.92	N/A	69.34	74.00	4.66
4882.000	V	X	AV	61.47	2.92	-30.81	33.58	54.00	20.42

▪ **Highest Channel**

Frequency (MHz)	ANT Pol	The worst case EUT Position (Axis)	Detector Mode	Reading (dBuV)	T.F (dB/m)	D.C.F. (dB)	Result (dBuV/m)	Limit (dBuV/m)	Margin (dB)
84.497	V	X	QP	51.16	-14.60	N/A	36.56	40.00	3.44
266.535	H	X	QP	49.64	-7.90	N/A	41.74	46.00	4.26
2483.500	V	X	PK	75.43	-4.66	N/A	70.77	74.00	3.23
2483.500	V	X	AV	70.37	-4.66	-30.81	34.90	54.00	19.10
4960.000	V	X	PK	66.68	2.67	N/A	69.35	74.00	4.65
4960.000	V	X	AV	61.23	2.67	-30.81	33.09	54.00	20.91

Note.

1. No other spurious and harmonic emissions were reported greater than listed emissions above table.
2. Above listed point data is the worst case data.
3. Sample Calculation.

Margin = Limit – Result / Result = Reading + T.F + D.C.F. / T.F = AF + CL – AG
 Where, T.F = Total Factor, AF = Antenna Factor, CL = Cable Loss, AG = Amplifier Gain,

4. Duty Cycle Correction Factor

- Time to cycle through all channels= $\Delta t = \tau_{[ms]} \times 79 \text{ channels} = 227.52ms$, where τ = pulse width
- $100ms / \Delta t_{[ms]} = H \rightarrow$ Round up to next highest integer, to account for worst case, $H' = 1$
- Worst Case Dwell Time = $\tau_{[ms]} \times H' = 2.88ms$
- Duty Cycle Correction = $20\log(\text{Worst Case Dwell Time} / 100ms)_{[dB]} = -30.81 \text{ dB}$

2.4.2. Conducted Spurious Emissions

Low Band-edge

Lowest Channel & Modulation: GFSK



Low Band-edge

Hopping mode & Modulation: GFSK



Conducted Spurious Emissions

Lowest Channel & Modulation: **GFSK**

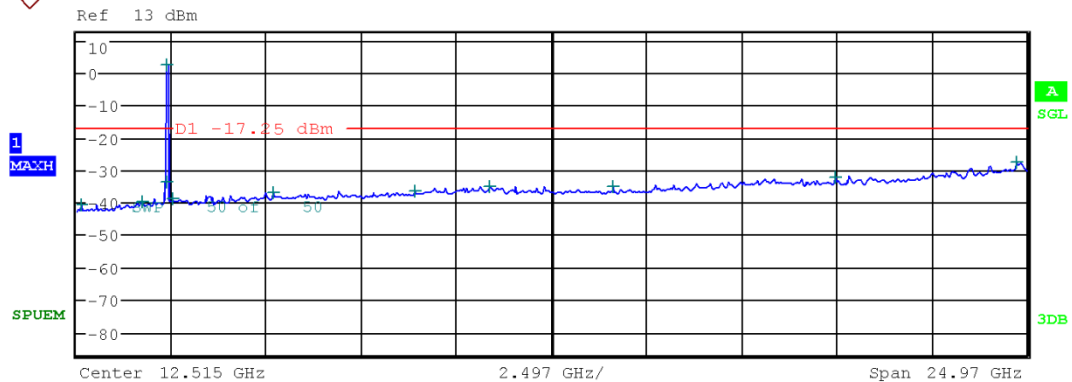
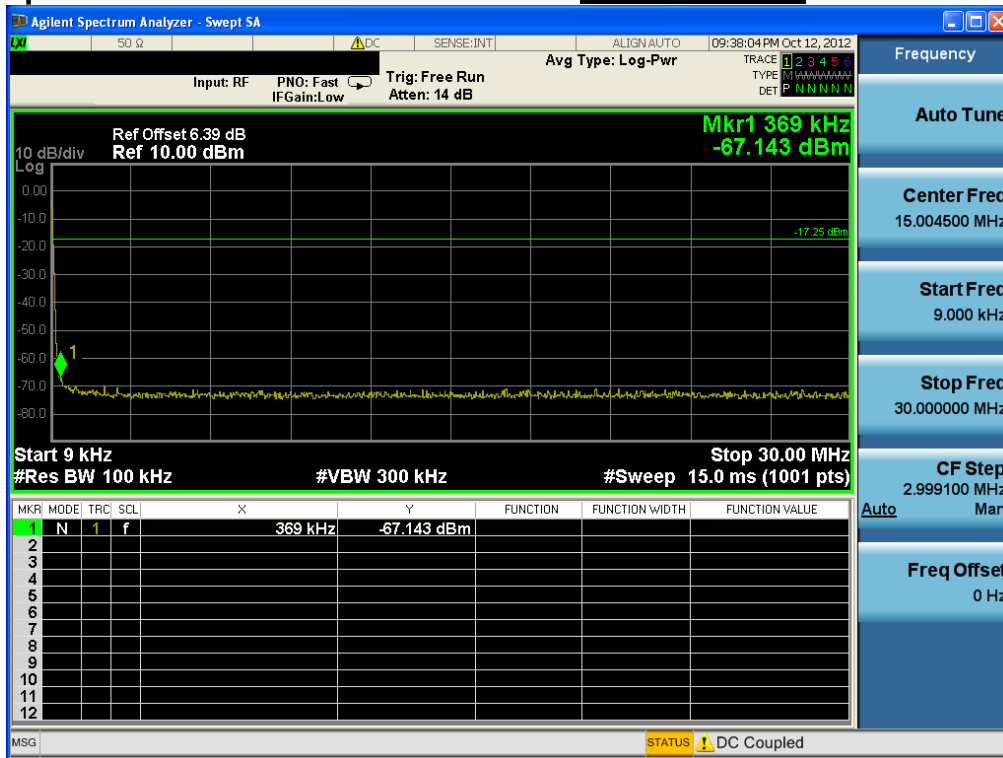

Start [Hz]	Stop [Hz]	RBW [Hz]	Freq [Hz]	PwrAbs [dBm]	Δ Limit [dB]
30.000 M	1.000 G	100.00 k	137.670000 M	-40.59	-200.00
1.000 G	2.000 G	100.00 k	1.761000 G	-39.81	-200.00
2.000 G	2.400 G	100.00 k	2.400000 G	-33.57	-200.00
2.400 G	2.483 G	100.00 k	2.402150 G	2.49	-200.00
2.483 G	3.000 G	100.00 k	2.559735 G	-38.89	-200.00
3.000 G	6.000 G	100.00 k	5.206667 G	-36.80	-200.00
6.000 G	9.000 G	100.00 k	8.913333 G	-36.49	-200.00
9.000 G	12.000 G	100.00 k	10.894000 G	-35.24	-200.00
12.000 G	15.000 G	100.00 k	14.116333 G	-35.31	-200.00
15.000 G	20.000 G	100.00 k	19.967778 G	-32.15	-200.00
20.000 G	25.000 G	100.00 k	24.707778 G	-27.53	-200.00

Reference for limit

Middle Channel & Modulation: GFSK

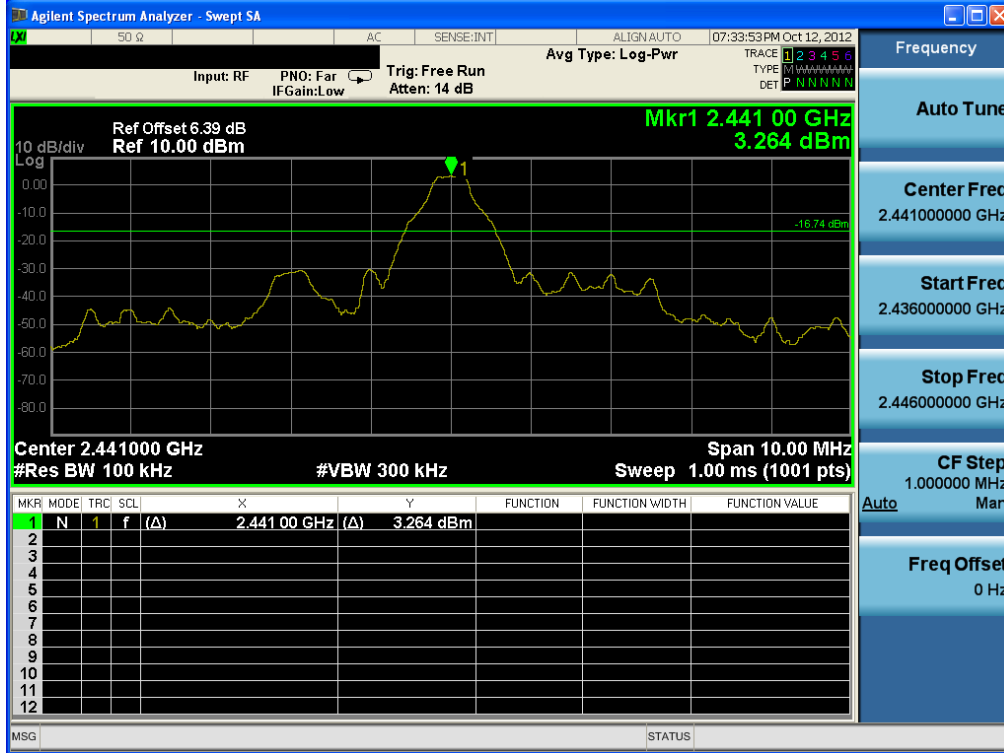

Conducted Spurious Emissions

Middle Channel & Modulation: GFSK

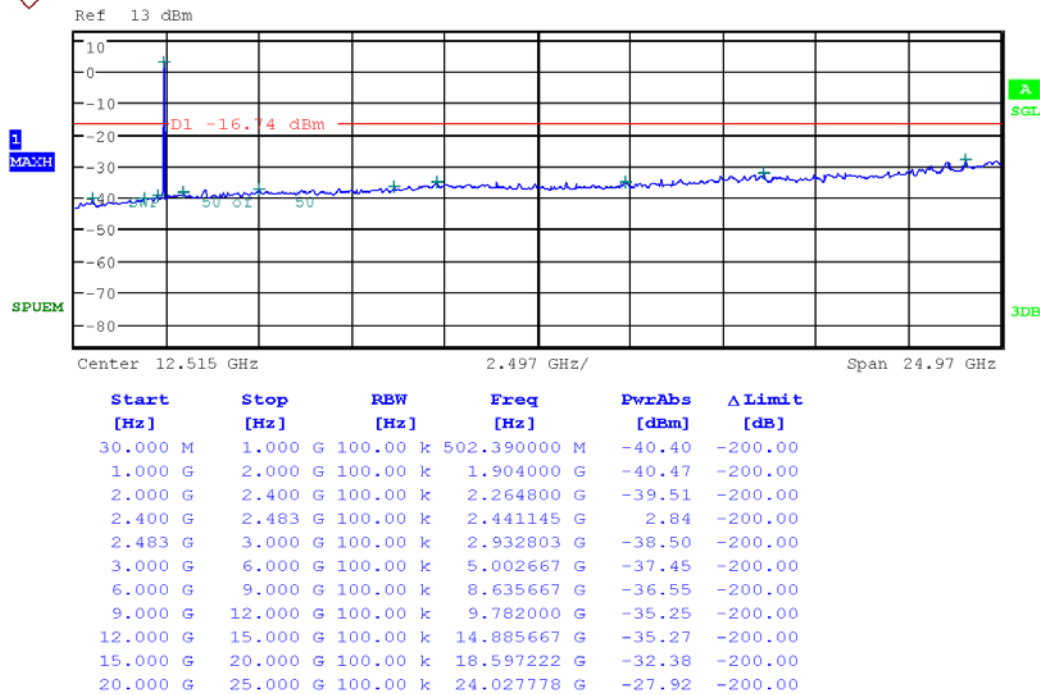
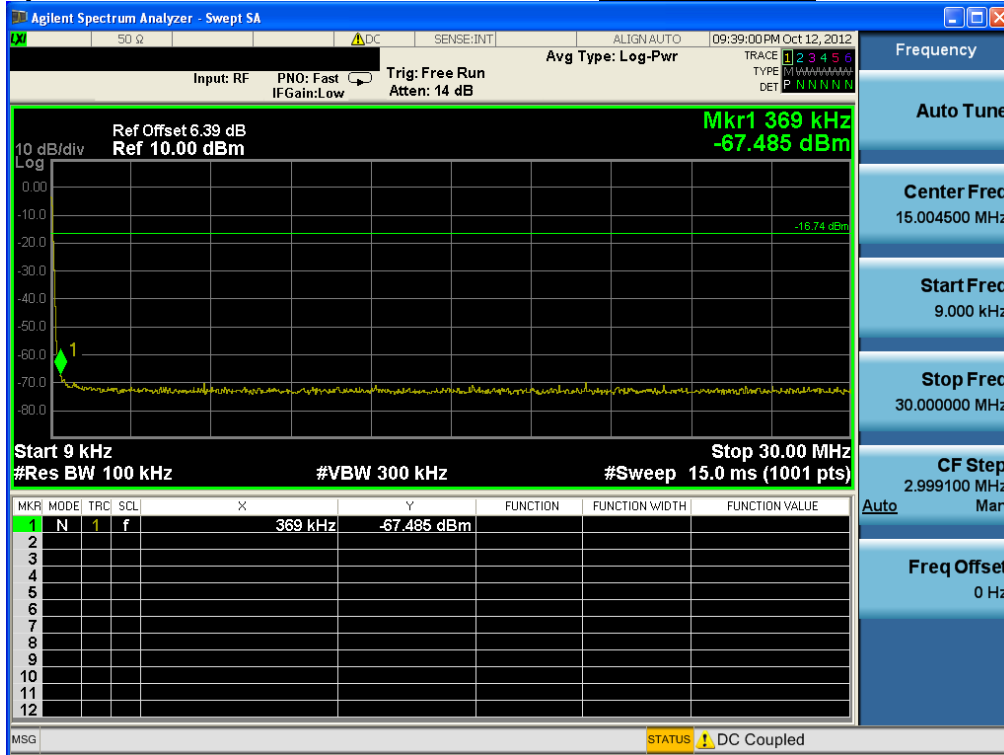

High Band-edge **Highest Channel** & Modulation: **GFSK**

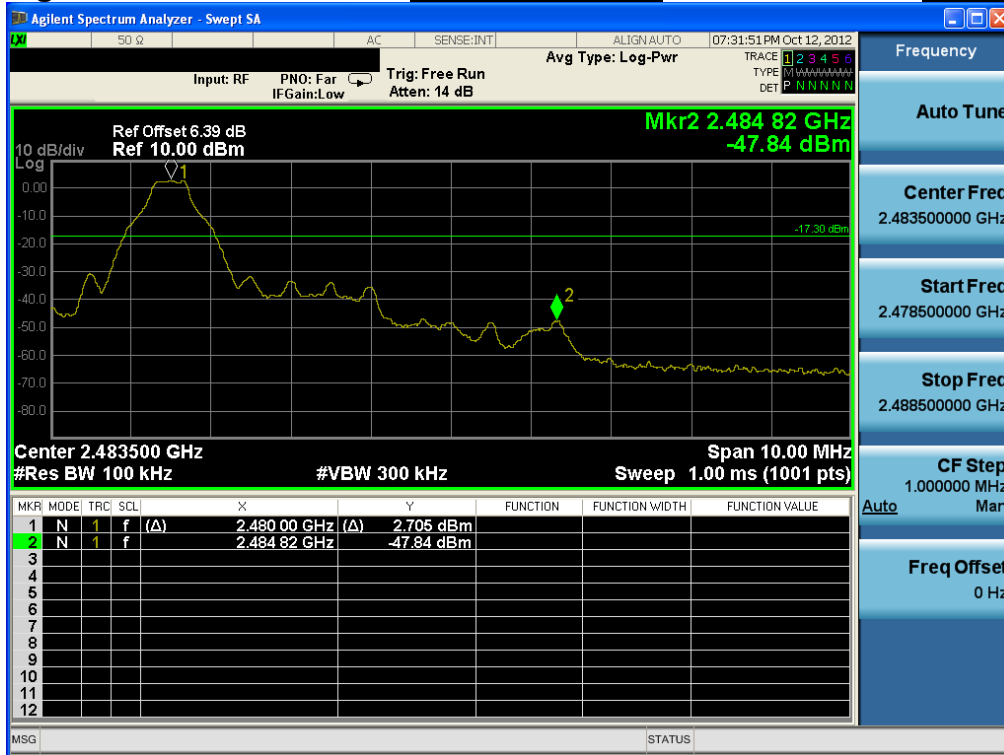

High Band-edge **Hopping mode** & Modulation: **GFSK**



Conducted Spurious Emissions

Highest Channel & Modulation: GFSK

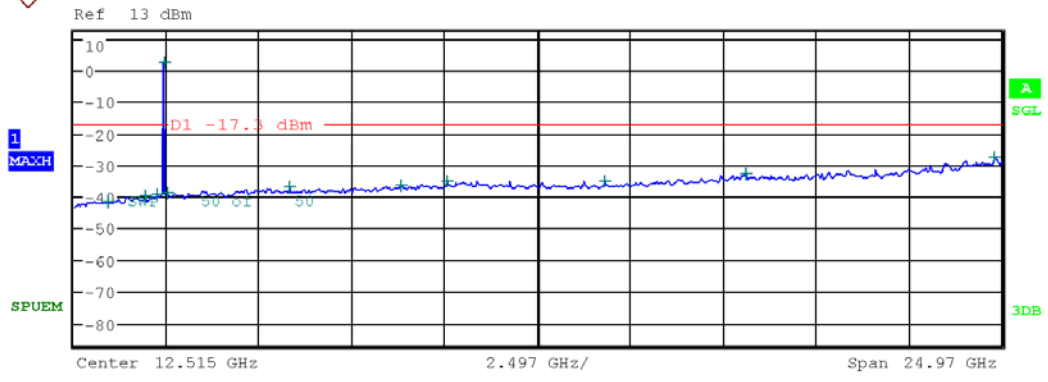
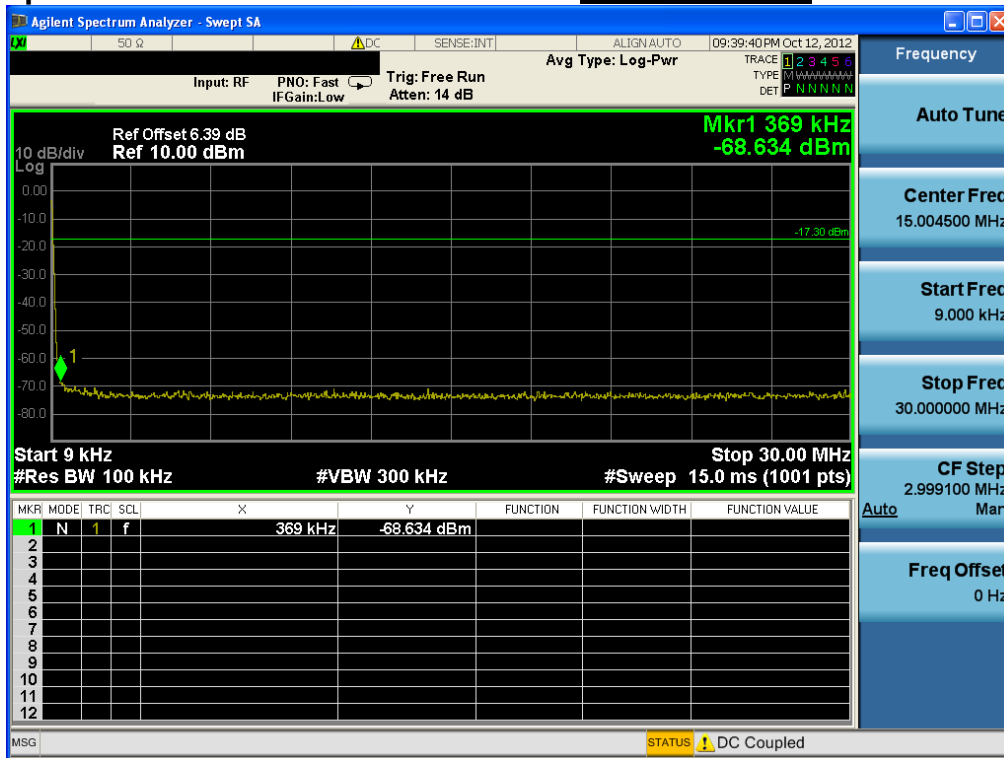

Start [Hz]	Stop [Hz]	RBW [Hz]	Freq [Hz]	PwrAbs [dBm]	Δ Limit [dB]
30.000 M	1.000 G	100.00 k	935.010000 M	-41.52	-200.00
1.000 G	2.000 G	100.00 k	1.939000 G	-39.91	-200.00
2.000 G	2.400 G	100.00 k	2.281720 G	-39.33	-200.00
2.400 G	2.483 G	100.00 k	2.479980 G	2.33	-200.00
2.483 G	3.000 G	100.00 k	2.543982 G	-38.86	-200.00
3.000 G	6.000 G	100.00 k	5.819000 G	-37.12	-200.00
6.000 G	9.000 G	100.00 k	8.838667 G	-36.72	-200.00
9.000 G	12.000 G	100.00 k	10.061333 G	-35.12	-200.00
12.000 G	15.000 G	100.00 k	14.310333 G	-35.01	-200.00
15.000 G	20.000 G	100.00 k	18.116111 G	-32.90	-200.00
20.000 G	25.000 G	100.00 k	24.796111 G	-27.42	-200.00

Low Band-edge Lowest Channel & Modulation: $\pi/4$ QPSK



Low Band-edge Hopping mode & Modulation: $\pi/4$ QPSK



Reference for limit

Middle Channel & Modulation: $\pi/4$ DQPSK



Conducted Spurious Emissions

Middle Channel & Modulation: $\pi/4$ DQPSK

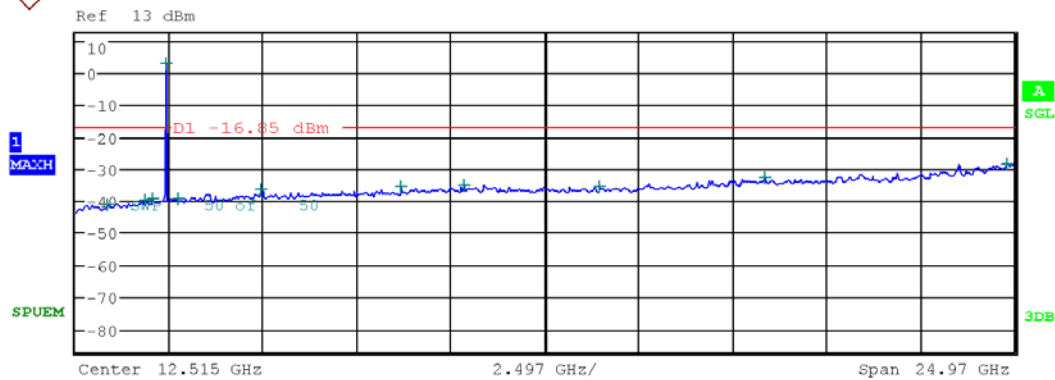
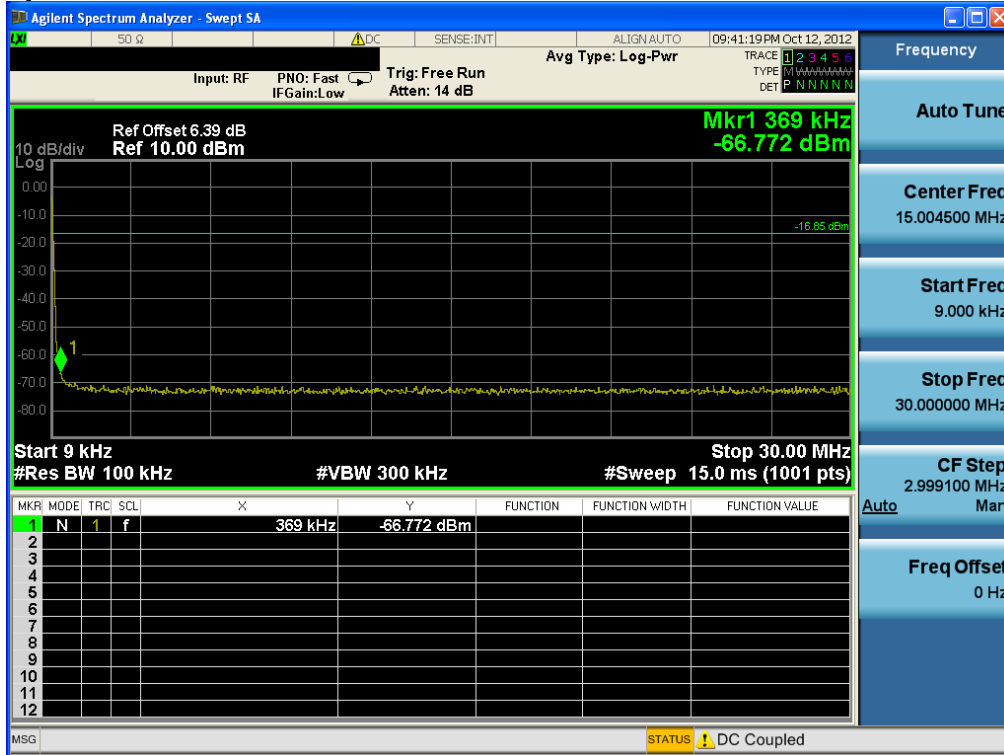

Start [Hz]	Stop [Hz]	RBW [Hz]	Freq [Hz]	PwrAbs [dBm]	Δ Limit [dB]
30.000 M	1.000 G	100.00 k	879.720000 M	-41.15	-200.00
1.000 G	2.000 G	100.00 k	1.852000 G	-39.86	-200.00
2.000 G	2.400 G	100.00 k	2.053280 G	-39.40	-200.00
2.400 G	2.483 G	100.00 k	2.440990 G	2.79	-200.00
2.483 G	3.000 G	100.00 k	2.731885 G	-39.18	-200.00
3.000 G	6.000 G	100.00 k	4.935667 G	-36.40	-200.00
6.000 G	9.000 G	100.00 k	8.660333 G	-35.83	-200.00
9.000 G	12.000 G	100.00 k	10.351333 G	-35.29	-200.00
12.000 G	15.000 G	100.00 k	13.950333 G	-35.42	-200.00
15.000 G	20.000 G	100.00 k	18.357222 G	-32.86	-200.00
20.000 G	25.000 G	100.00 k	24.792778 G	-28.53	-200.00

High Band-edge Highest Channel & Modulation: $\pi/4$ DQPSK



High Band-edge Hopping mode & Modulation: $\pi/4$ DQPSK



Conducted Spurious Emissions

Highest Channel & Modulation: $\pi/4$ DQPSK

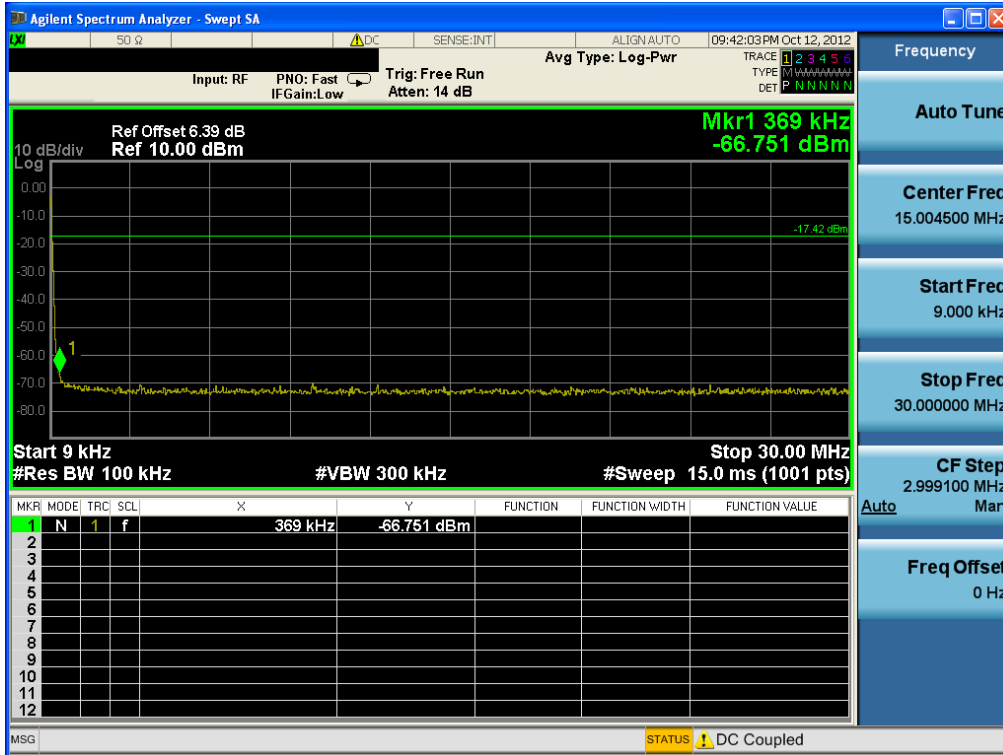

Ref 13 dBm

1 MAXH

SPUEM

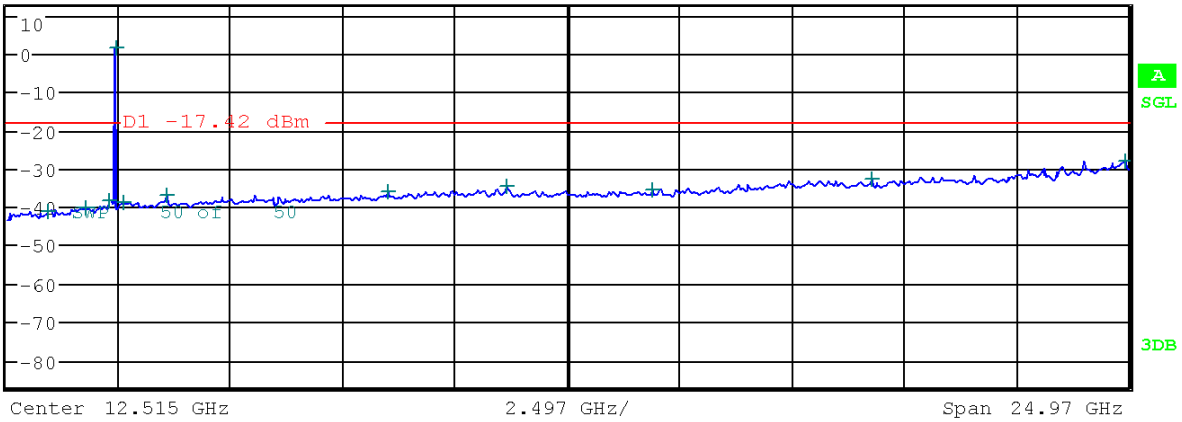

Start [Hz]	Stop [Hz]	RBW [Hz]	Freq [Hz]	PwrAbs [dBm]	Δ Limit [dB]
30.000 M	1.000 G	100.00 k	947.620000 M	-41.31	-200.00
1.000 G	2.000 G	100.00 k	1.797000 G	-40.44	-200.00
2.000 G	2.400 G	100.00 k	2.305960 G	-38.34	-200.00
2.400 G	2.483 G	100.00 k	2.480031 G	1.56	-200.00
2.483 G	3.000 G	100.00 k	2.616912 G	-38.65	-200.00
3.000 G	6.000 G	100.00 k	3.572000 G	-37.08	-200.00
6.000 G	9.000 G	100.00 k	8.524000 G	-36.21	-200.00
9.000 G	12.000 G	100.00 k	11.159333 G	-34.69	-200.00
12.000 G	15.000 G	100.00 k	14.382333 G	-35.42	-200.00
15.000 G	20.000 G	100.00 k	19.266111 G	-33.00	-200.00
20.000 G	25.000 G	100.00 k	24.913889 G	-27.89	-200.00

Low Band-edge **Lowest Channel** & Modulation: **8DPSK**



Low Band-edge **Hopping mode** & Modulation: **8DPSK**

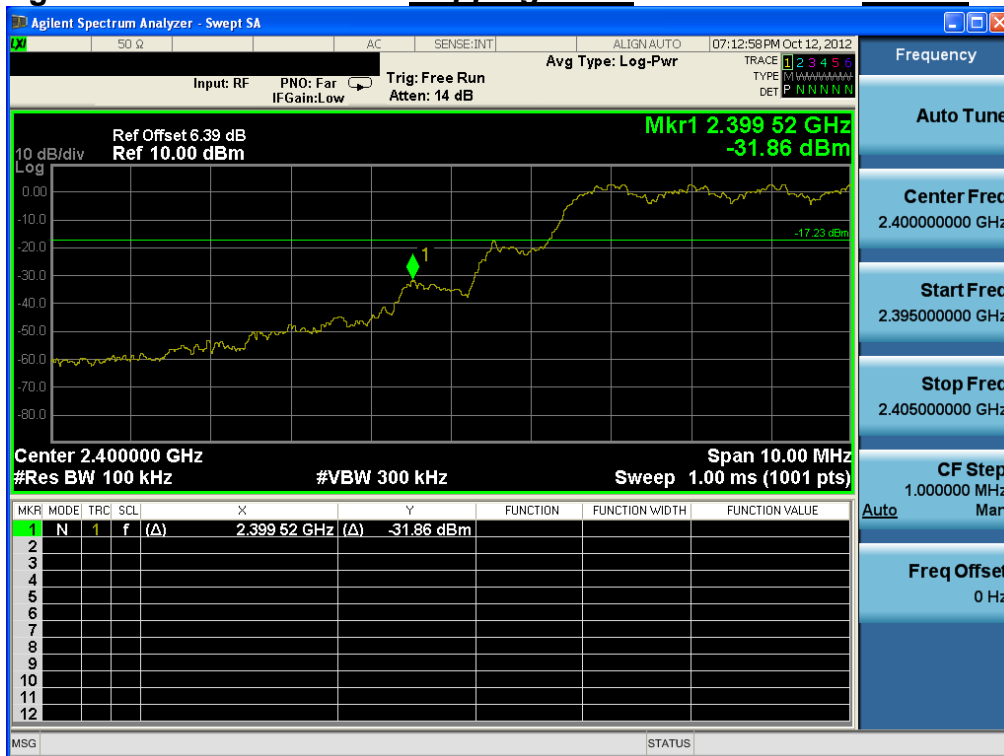

Conducted Spurious Emissions

Lowest Channel & Modulation: 8DPSK

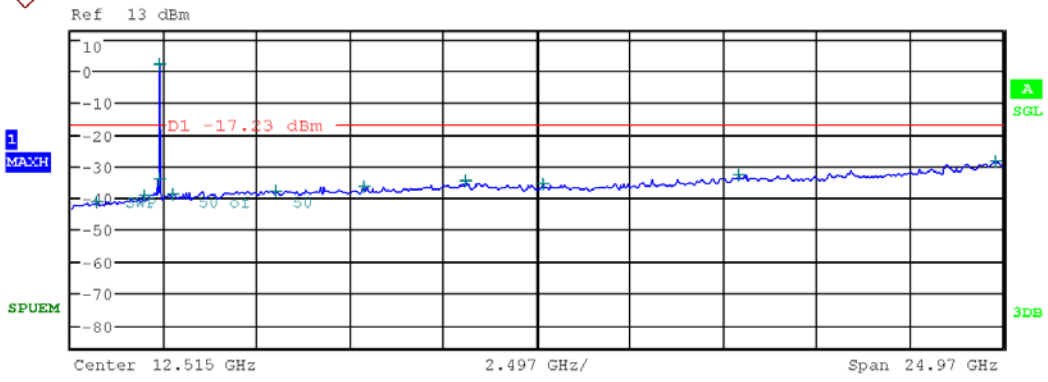
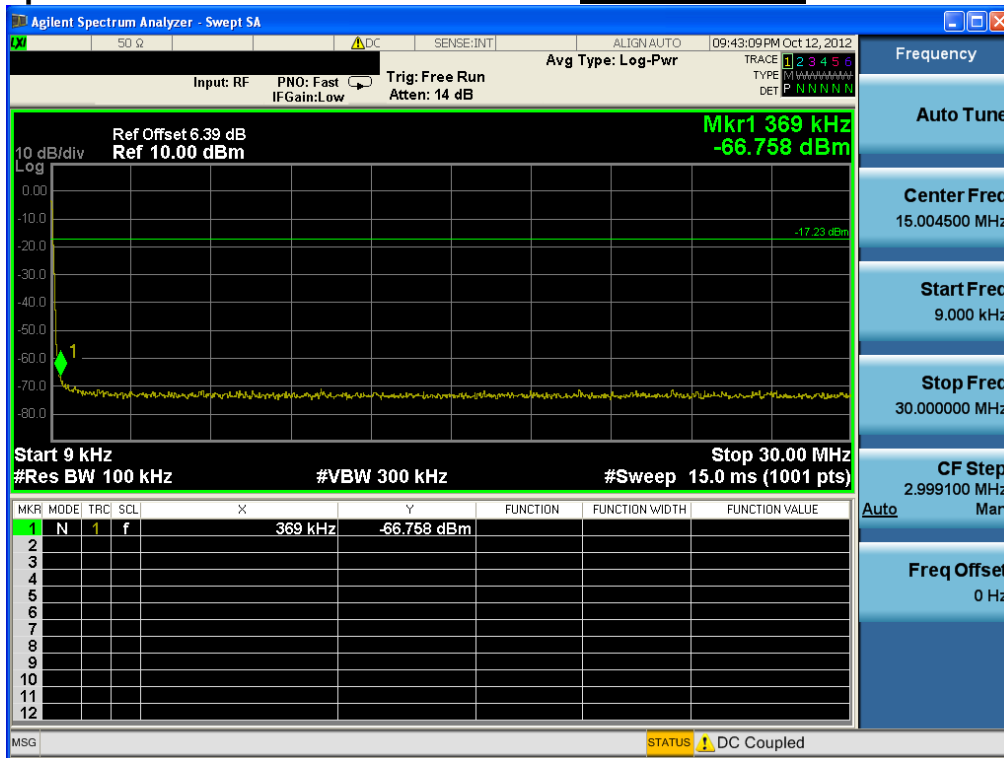

Start [Hz]	Stop [Hz]	RBW [Hz]	Freq [Hz]	PwrAbs [dBm]	Δ Limit [dB]
30.000 M	1.000 G	100.00 k	716.760000 M	-41.21	-200.00
1.000 G	2.000 G	100.00 k	1.991000 G	-39.23	-200.00
2.000 G	2.400 G	100.00 k	2.399480 G	-34.07	-200.00
2.400 G	2.483 G	100.00 k	2.401996 G	2.03	-200.00
2.483 G	3.000 G	100.00 k	2.759053 G	-38.75	-200.00
3.000 G	6.000 G	100.00 k	5.523000 G	-37.75	-200.00
6.000 G	9.000 G	100.00 k	7.854333 G	-36.31	-200.00
9.000 G	12.000 G	100.00 k	10.585333 G	-34.82	-200.00
12.000 G	15.000 G	100.00 k	12.669000 G	-35.41	-200.00
15.000 G	20.000 G	100.00 k	17.918333 G	-32.79	-200.00
20.000 G	25.000 G	100.00 k	24.796667 G	-28.50	-200.00

Reference for limit

Middle Channel & Modulation: **8DPSK**



Conducted Spurious Emissions

Middle Channel & Modulation: 8DPSK

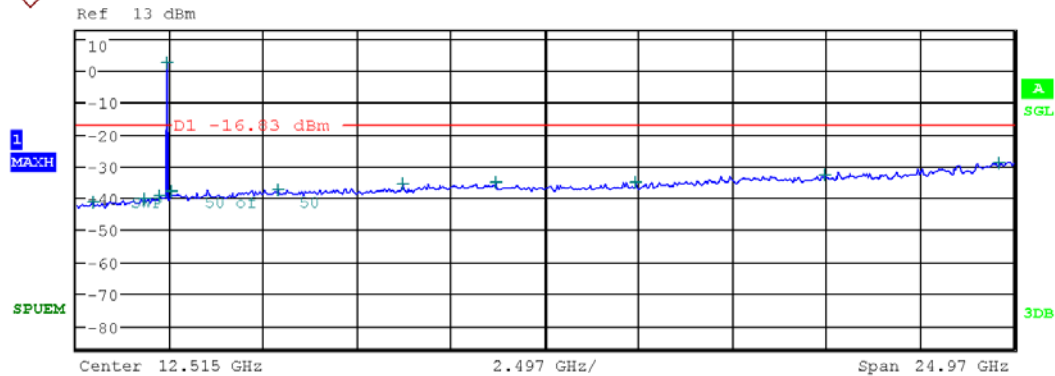
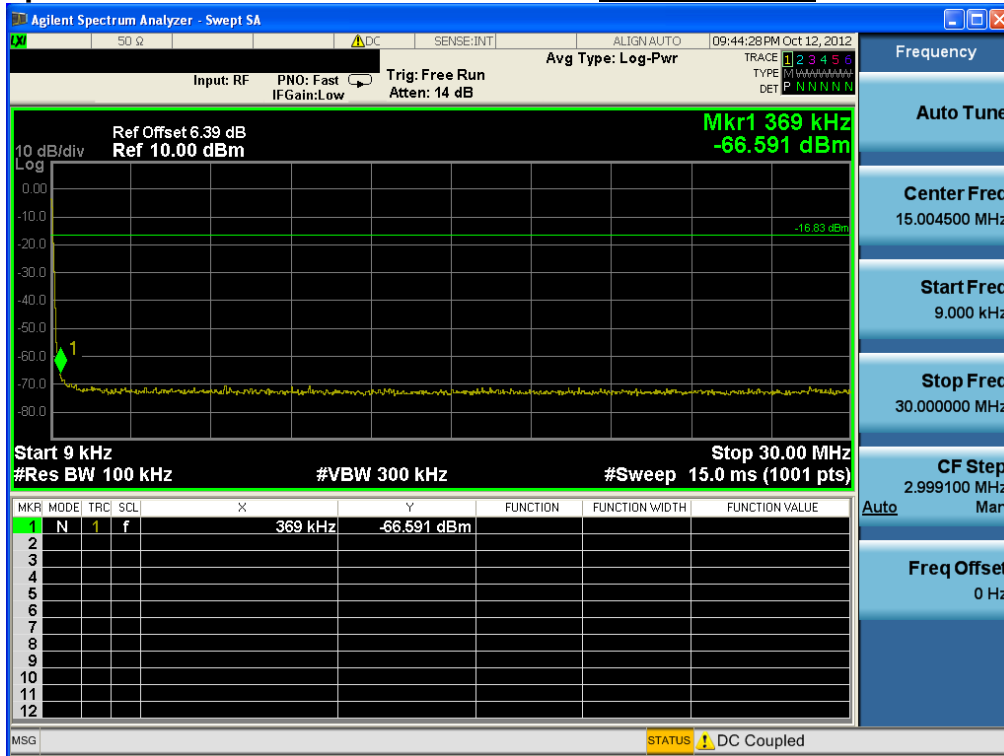

Start [Hz]	Stop [Hz]	RBW [Hz]	Freq [Hz]	PwrAbs [dBm]	Δ Limit [dB]
30.000 M	1.000 G	100.00 k	454.860000 M	-41.11	-200.00
1.000 G	2.000 G	100.00 k	1.837000 G	-40.15	-200.00
2.000 G	2.400 G	100.00 k	2.248880 G	-39.32	-200.00
2.400 G	2.483 G	100.00 k	2.440990 G	2.52	-200.00
2.483 G	3.000 G	100.00 k	2.563712 G	-38.00	-200.00
3.000 G	6.000 G	100.00 k	5.396667 G	-37.30	-200.00
6.000 G	9.000 G	100.00 k	8.714667 G	-35.68	-200.00
9.000 G	12.000 G	100.00 k	11.192667 G	-35.08	-200.00
12.000 G	15.000 G	100.00 k	14.925333 G	-35.11	-200.00
15.000 G	20.000 G	100.00 k	19.951667 G	-33.00	-200.00
20.000 G	25.000 G	100.00 k	24.619444 G	-28.81	-200.00

High Band-edge

Highest Channel & Modulation: 8DPSK



High Band-edge

Hopping mode & Modulation: 8DPSK



Conducted Spurious Emissions

Highest Channel & Modulation: **8DPSK**

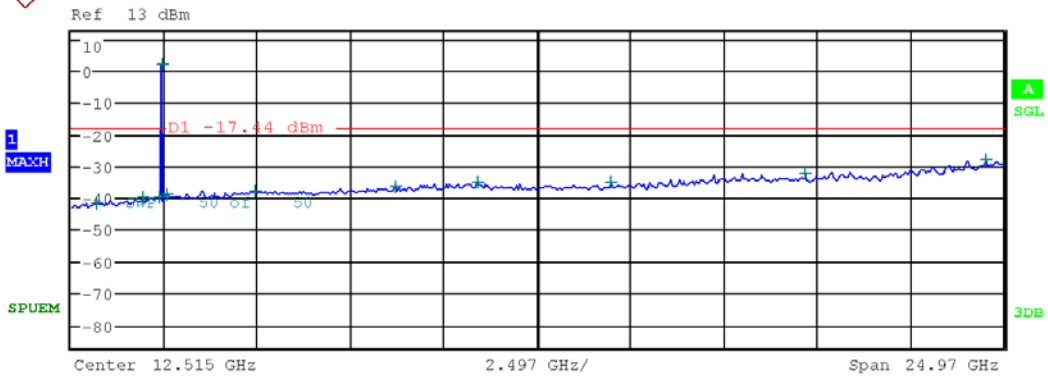
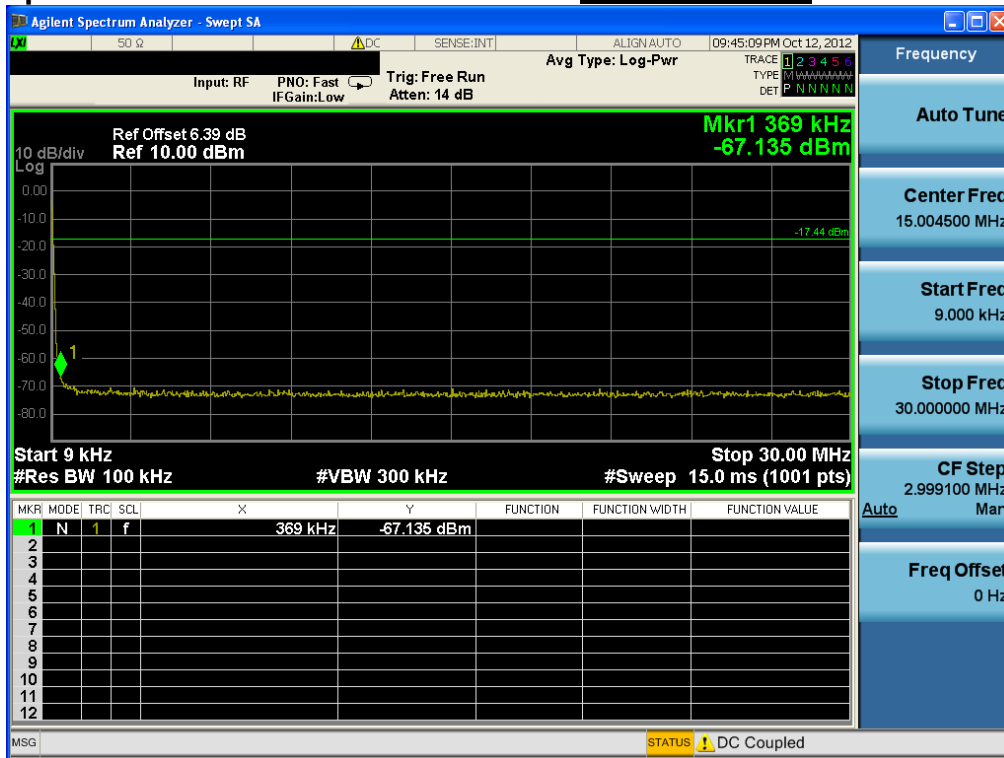

Start [Hz]	Stop [Hz]	RBW [Hz]	Freq [Hz]	PwrAbs [dBm]	Δ Limit [dB]
30.000 M	1.000 G	100.00 k	728.400000 M	-41.61	-200.00
1.000 G	2.000 G	100.00 k	1.958000 G	-39.95	-200.00
2.000 G	2.400 G	100.00 k	2.395520 G	-39.63	-200.00
2.400 G	2.483 G	100.00 k	2.479997 G	1.81	-200.00
2.483 G	3.000 G	100.00 k	2.597027 G	-38.86	-200.00
3.000 G	6.000 G	100.00 k	4.939000 G	-37.79	-200.00
6.000 G	9.000 G	100.00 k	8.715667 G	-36.32	-200.00
9.000 G	12.000 G	100.00 k	10.901000 G	-34.96	-200.00
12.000 G	15.000 G	100.00 k	14.473000 G	-35.33	-200.00
15.000 G	20.000 G	100.00 k	19.671667 G	-32.13	-200.00
20.000 G	25.000 G	100.00 k	24.519444 G	-28.28	-200.00

3. Carrier Frequency Separation

3.1. Test Setup

Refer to the APPENDIX I.

3.2. Limit

Limit: $\geq 20\text{dB BW}$ or $\geq \text{Two-Thirds of the } 20\text{dB BW}$

- Procedure:

The carrier frequency separation was measured with a spectrum analyzer connected to the antenna terminal, while EUT had its hopping function enabled.

After the trace being stable, the reading value between the peaks of the adjacent channels using the marker-delta function was recorded as the measurement results.

The spectrum analyzer is set to:

- Span = wide enough to capture the peaks of two adjacent channels
- RBW = 1% of the span
- VBW = \geq RBW
- Trace = max hold
- Sweep = auto
- Detector function = peak

- Measurement Data: Comply

- FH mode

Hopping Mode	Test Mode	Peak of center channel (MHz)	Peak of adjacent Channel (MHz)	Test Result (MHz)
Enable	Test Case 1	2439.995	2440.997	1.002
	Test Case 2	2439.998	2441.000	1.002
	Test Case 3	2440.988	2441.990	1.002

- AFH mode

Hopping Mode	Test Mode	Peak of center channel (MHz)	Peak of adjacent Channel (MHz)	Test Result (MHz)
Enable	Test Case 1	2409.995	2410.997	1.002
	Test Case 2	2410.994	2411.996	1.002
	Test Case 3	2409.992	2410.994	1.002

Note 1: See next pages for actual measured spectrum plots.

- Minimum Standard:

Frequency hopping systems shall have hopping channel carrier frequencies separated by a minimum of 25 kHz or the 20 dB bandwidth of the hopping channel, whichever is greater.
 Alternatively, frequency hopping systems operating in the 2400-2483.5 MHz band may have hopping channel carrier frequencies that are separated by 25 kHz or two-thirds of the 20 dB bandwidth of the hopping channel, whichever is greater, provided the systems operate with an output power no greater than 125 mW

Carrier Frequency Separation (FH)

Hopping mode: Enable&Test Case 1



Carrier Frequency Separation (FH)

Hopping mode: Enable&Test Case 2

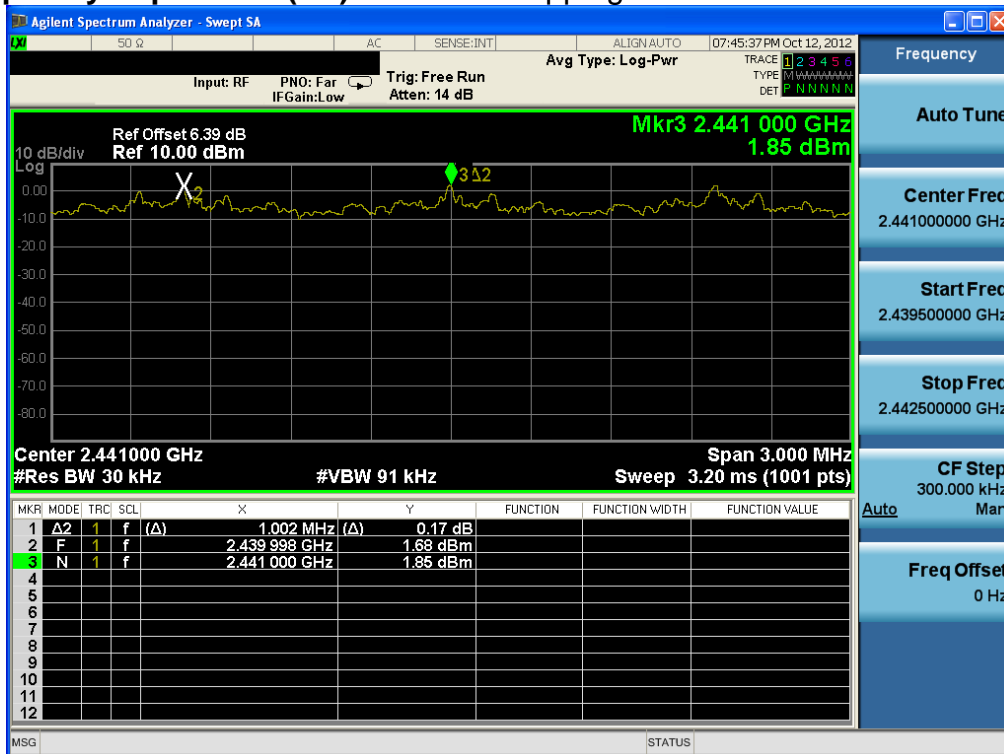

Carrier Frequency Separation (FH)

Hopping mode: Enable&Test Case 3

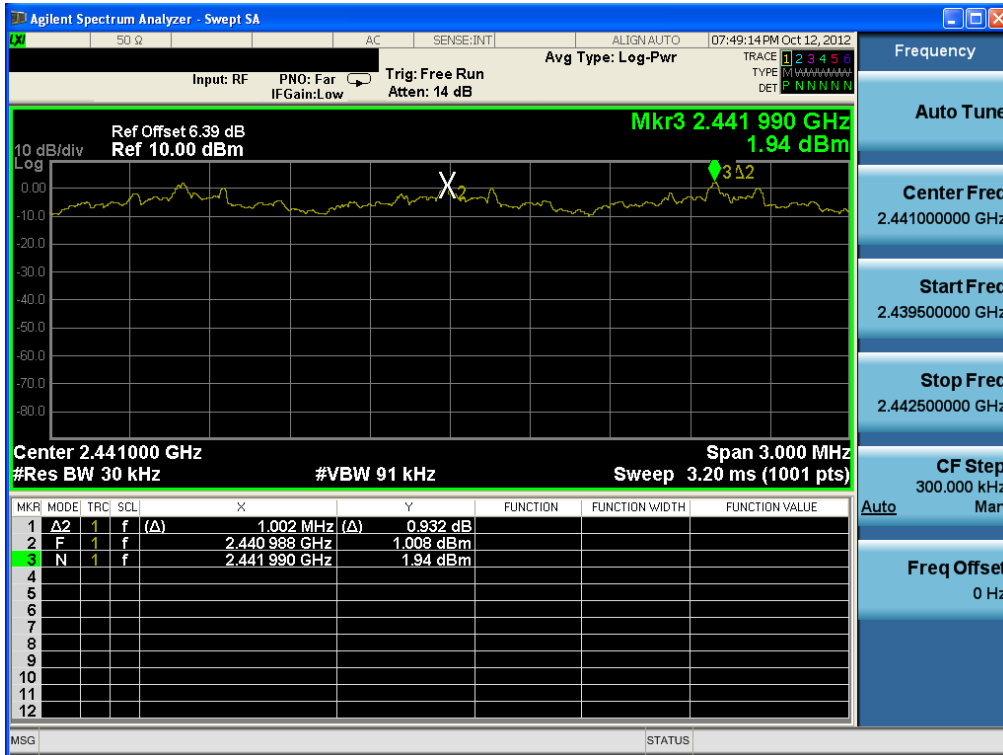

Carrier Frequency Separation (AFH)

Hopping mode: Enable&Test Case 1

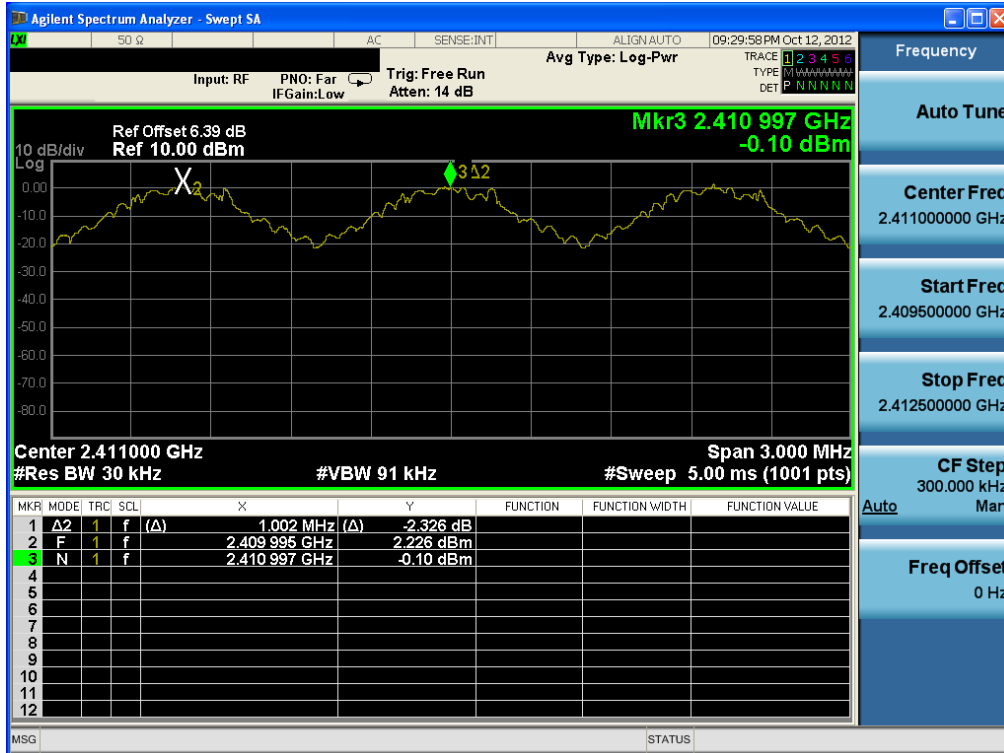

Carrier Frequency Separation (AFH)

Hopping mode: Enable&Test Case 2

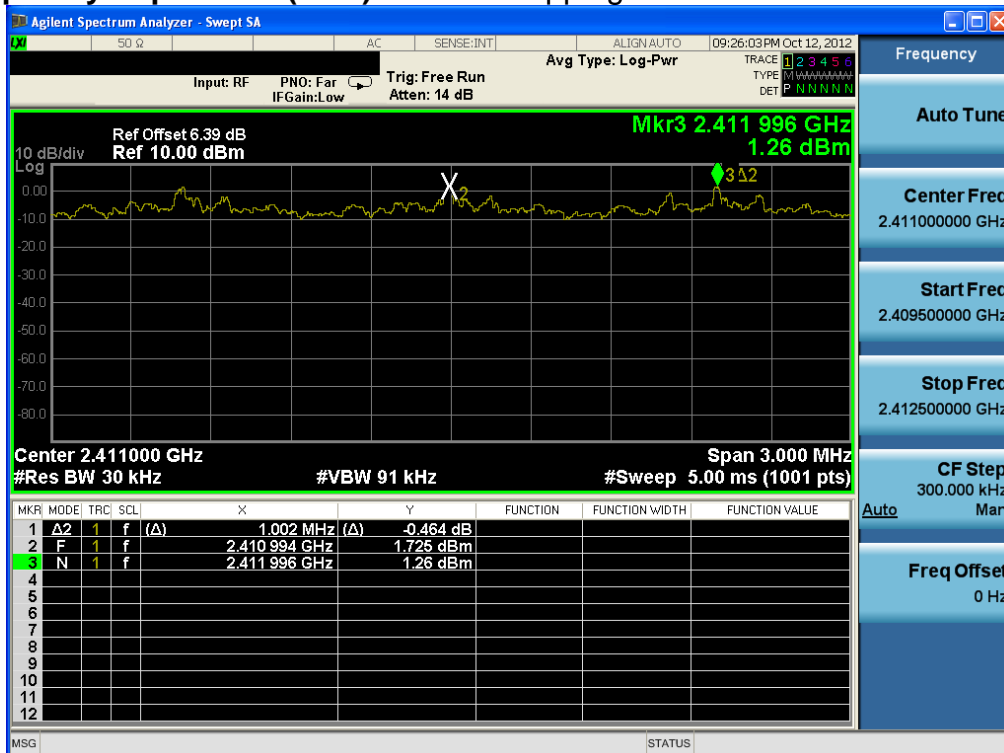

Carrier Frequency Separation (AFH)

Hopping mode: Enable&Test Case 3



4. Number of Hopping Frequencies

4.1. Test Setup

Refer to the APPENDIX I.

4.2. Limit

Limit: >= 15 hops

- Procedure:

The number of hopping frequencies was measured with a spectrum analyzer connected to the antenna terminal, while EUT had its hopping function enabled.

To get higher resolution, four frequency ranges within the 2400 ~ 2483.5 MHz FH band were examined.

The spectrum analyzer is set to:

Span = 25MHz	Plot 1(FH): Start Frequency = 2389.5MHz, Stop Frequency = 2414.5 MHz
	Plot 2(FH): Start Frequency = 2414.5MHz, Stop Frequency = 2439.5 MHz
	Plot 3(FH): Start Frequency = 2439.5MHz, Stop Frequency = 2464.5 MHz
	Plot 4(FH): Start Frequency = 2464.5MHz, Stop Frequency = 2489.5 MHz
	Plot 1(AFH) : Start Frequency = 2398.5MHz, Stop Frequency = 2423.5 MHz
RBW = 1% of the span or more	Sweep = auto
VBW = ≥ RBW	Detector function = peak
Trace = max hold	

- Measurement Data: **Comply**

FH mode

Hopping mode	Test mode	Test Result(Total Hops)
Enable	Test Case 1	79
	Test Case 2	79
	Test Case 3	79

AFH mode

Hopping mode	Test mode	Test Result(Total Hops)
Enable	Test Case 1	20
	Test Case 2	20
	Test Case 3	20

Note 1: See next pages for actual measured spectrum plots.

- Minimum Standard:

At least 15 hopes

Number of Hopping Frequencies 1(FH) Hopping mode: Enable & Test Case 1

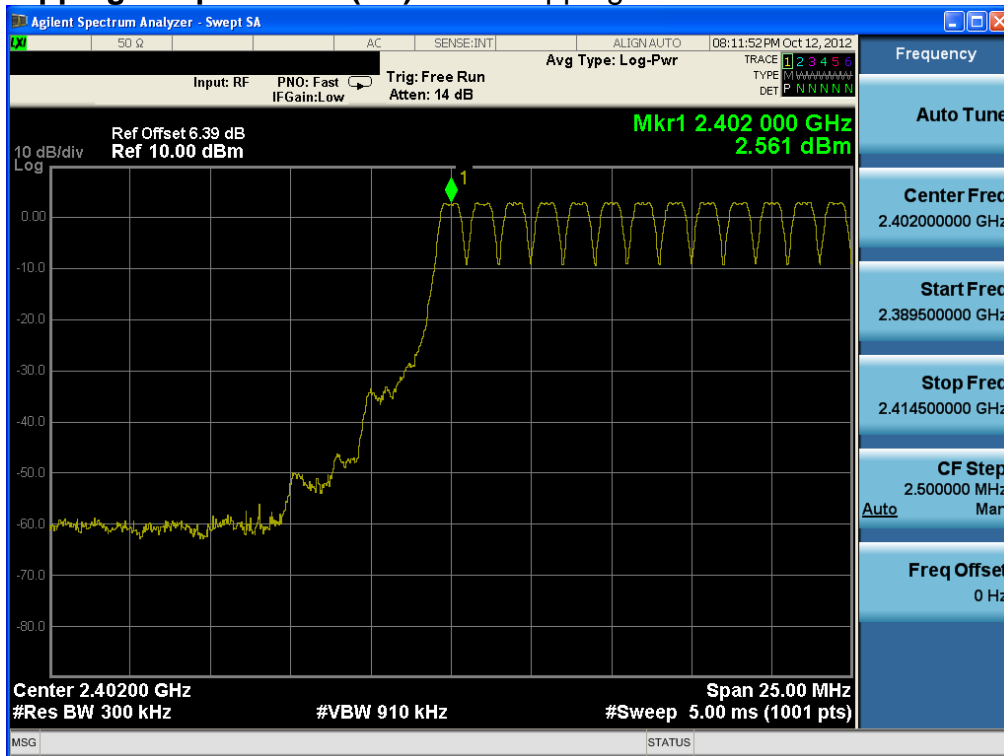

Number of Hopping Frequencies 2(FH) Hopping mode: Enable & Test Case 1

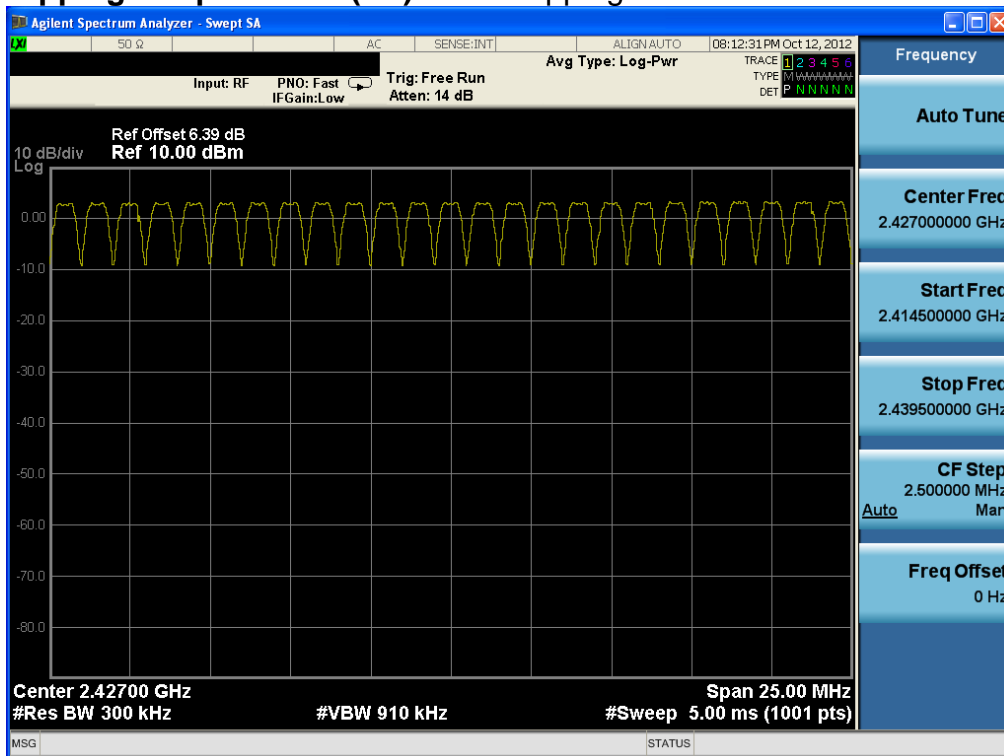

Number of Hopping Frequencies 3(FH) Hopping mode: Enable & Test Case 1

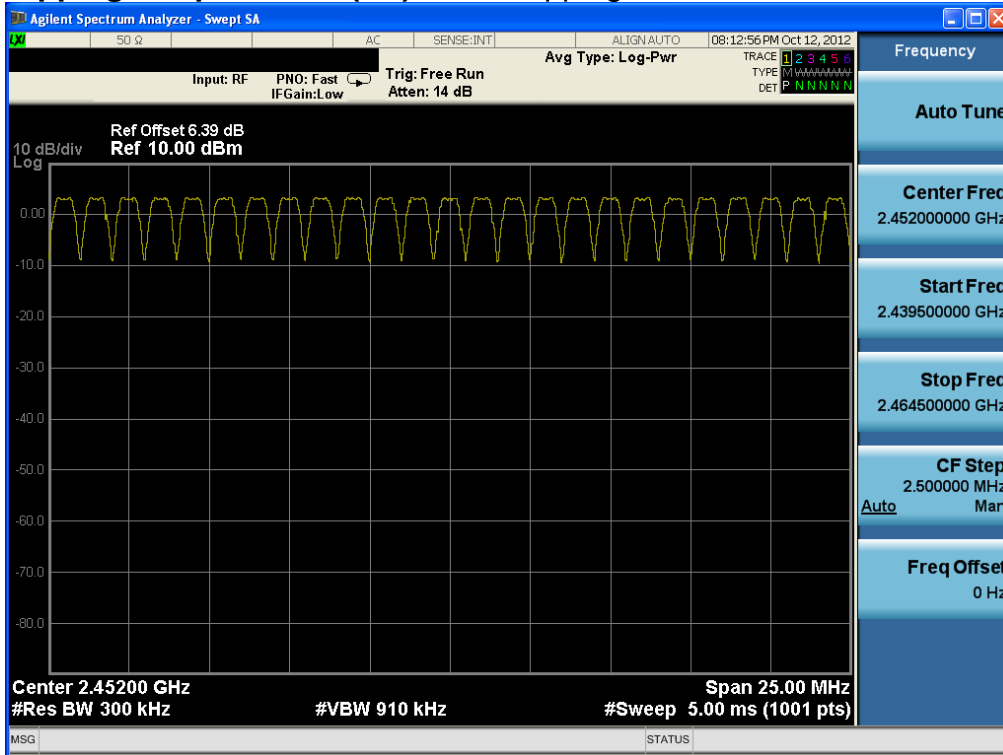

Number of Hopping Frequencies 4(FH) Hopping mode: Enable & Test Case 1

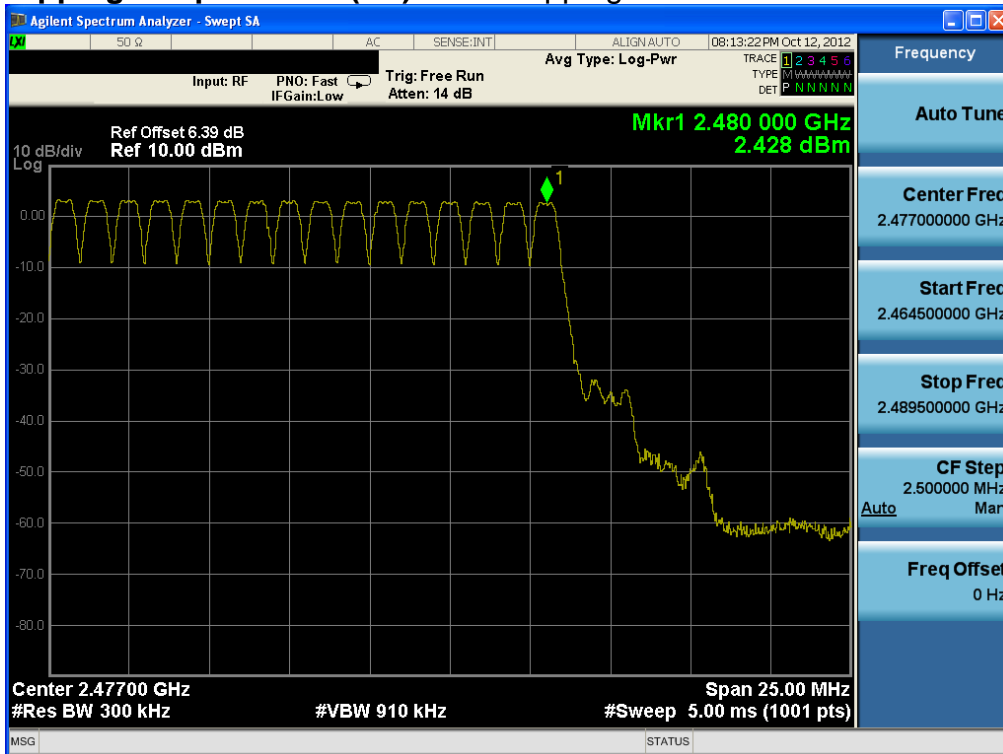

Number of Hopping Frequencies 1(FH) Hopping mode: Enable & Test Case 2

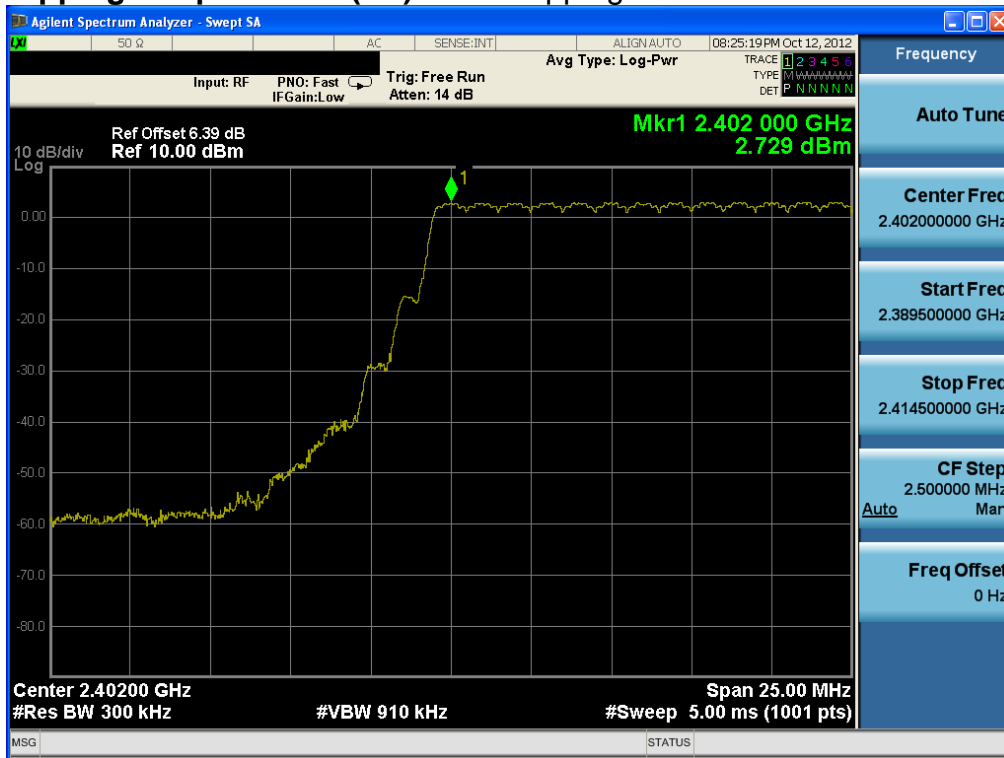

Number of Hopping Frequencies 2(FH) Hopping mode: Enable & Test Case 2

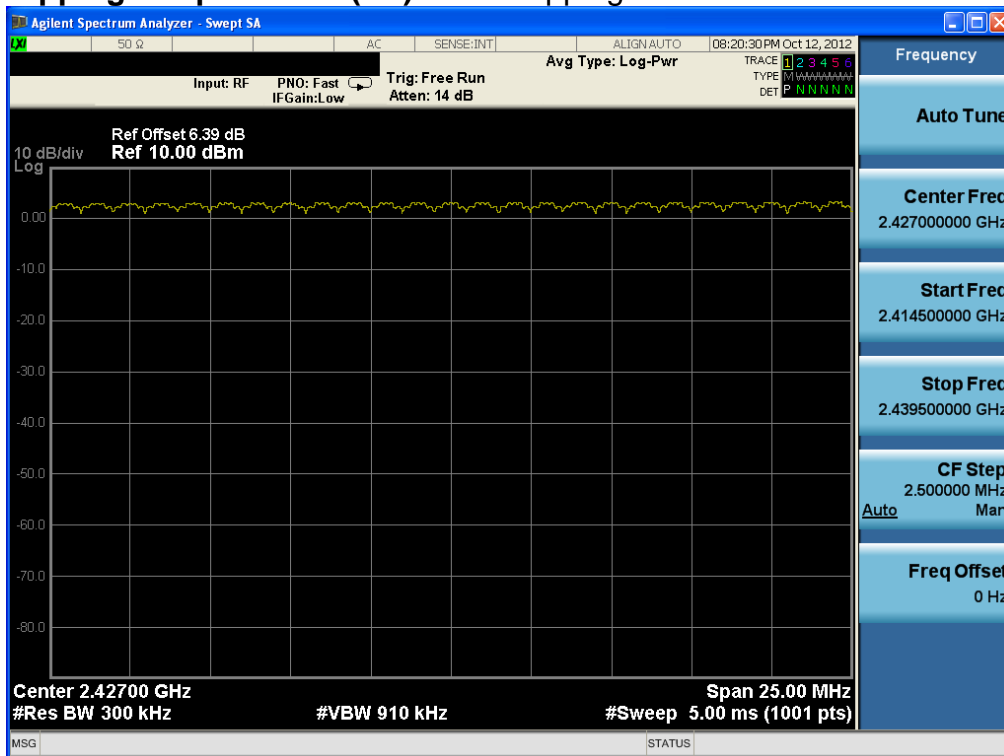

Number of Hopping Frequencies 3(FH) Hopping mode: Enable & Test Case 2

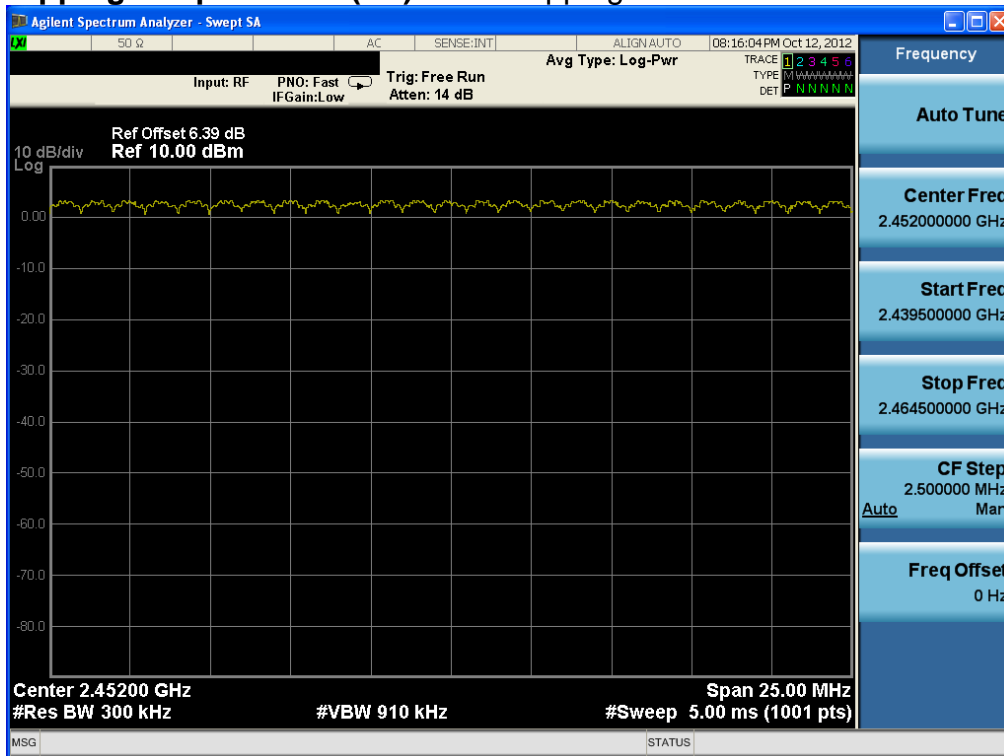

Number of Hopping Frequencies 4(FH) Hopping mode: Enable & Test Case 2

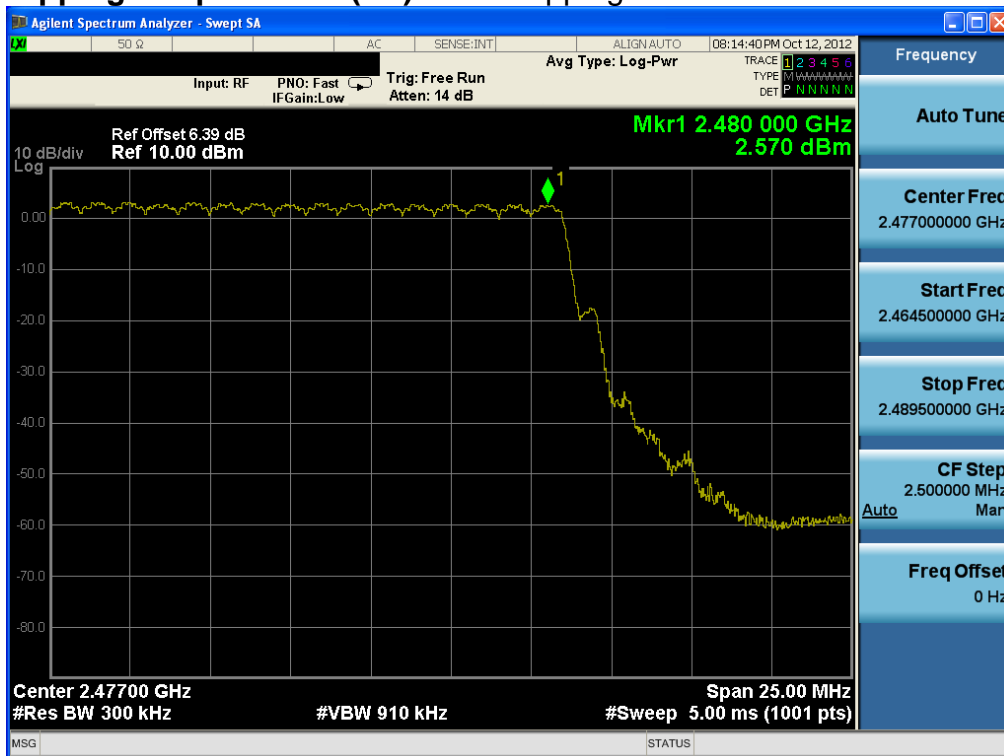

Number of Hopping Frequencies 1(FH) Hopping mode: Enable & Test Case 3

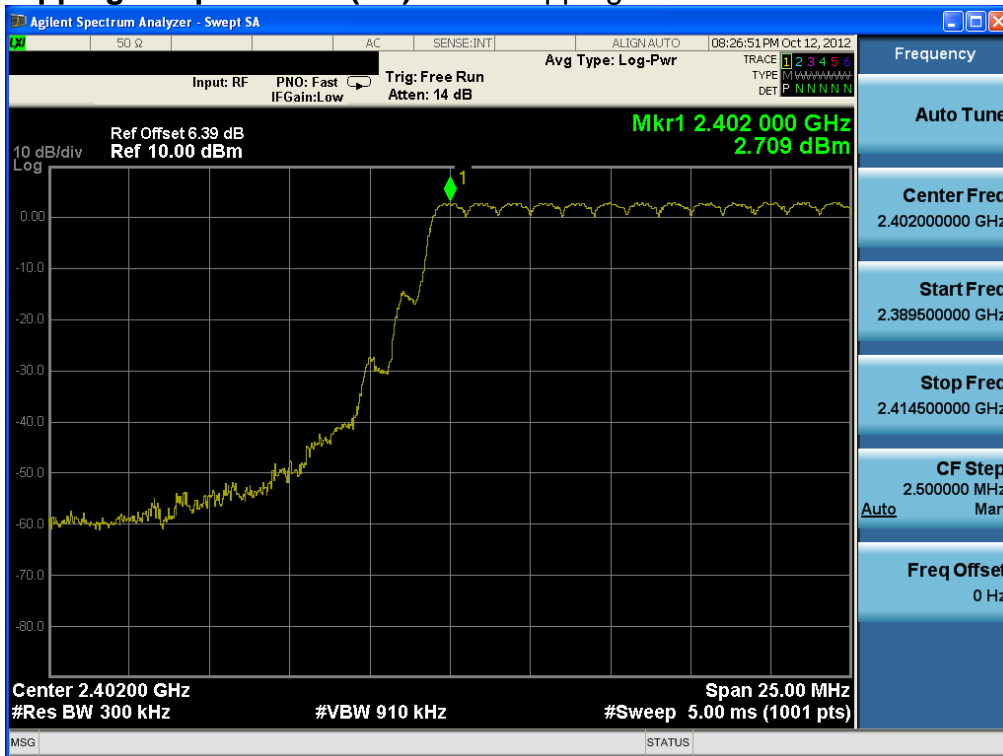

Number of Hopping Frequencies 2(FH) Hopping mode: Enable & Test Case 3

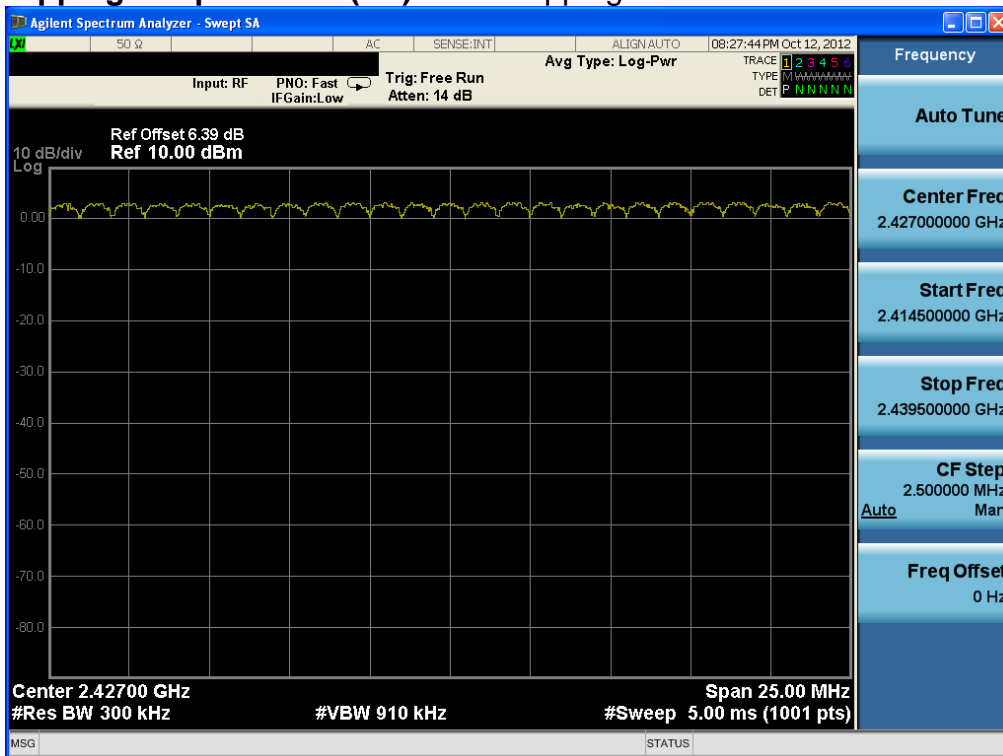

Number of Hopping Frequencies 3(FH) Hopping mode: Enable & Test Case 3

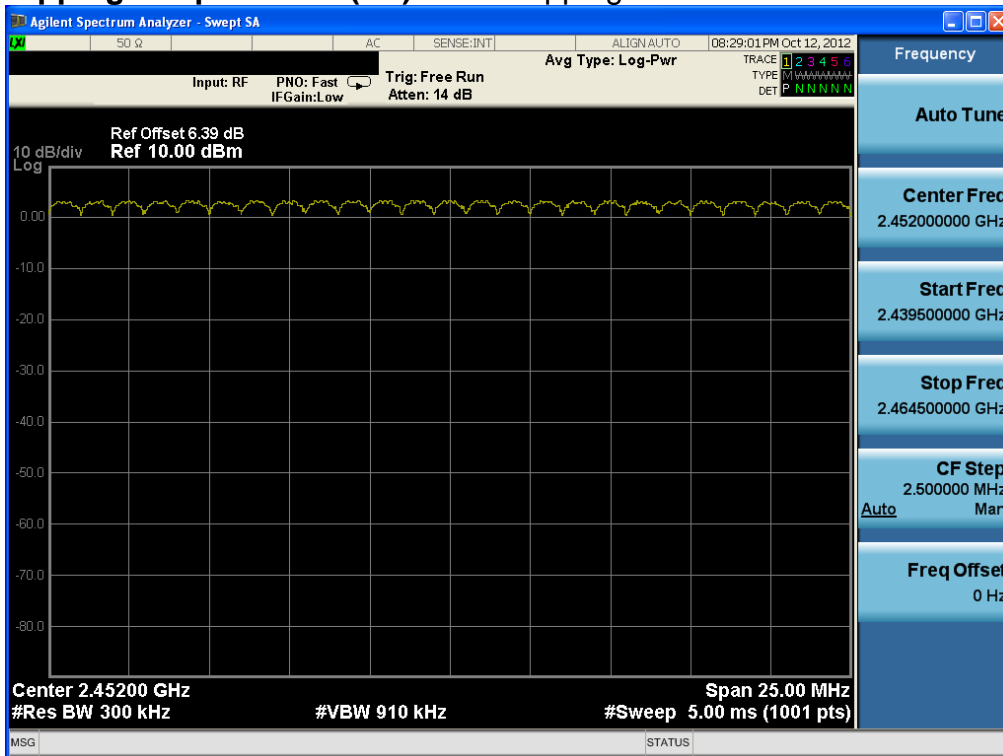

Number of Hopping Frequencies 4(FH) Hopping mode: Enable & Test Case 3



Number of Hopping Frequencies 1(AFH) Hopping mode: Enable & Test Case 1

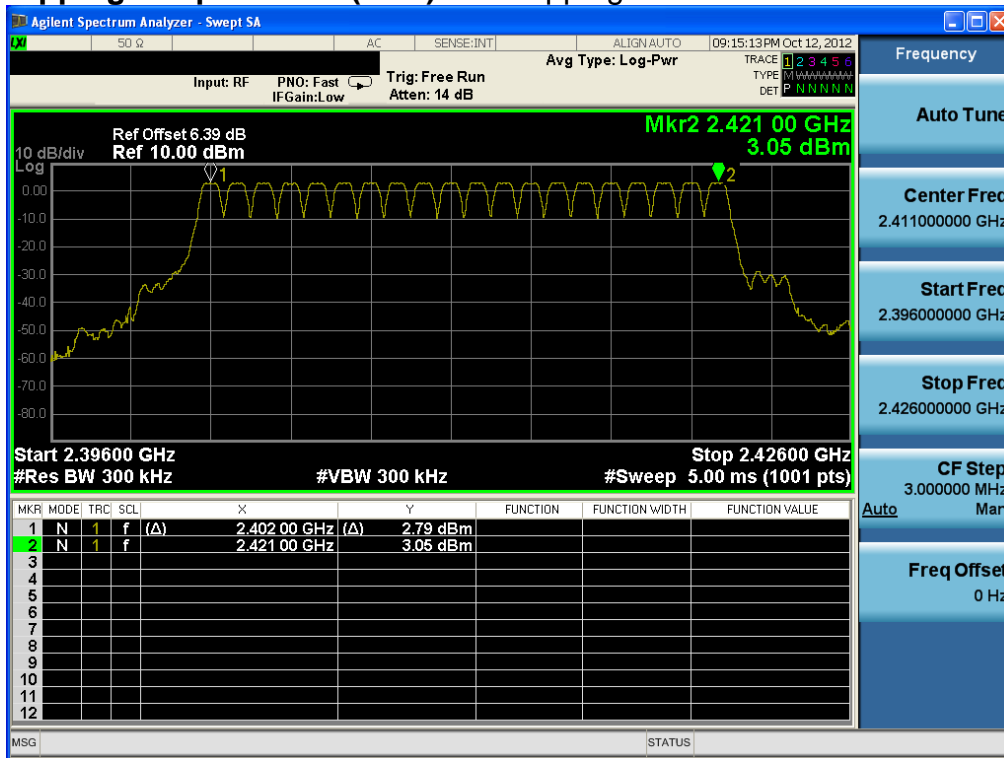

Number of Hopping Frequencies 1(AFH) Hopping mode: Enable & Test Case 2



Number of Hopping Frequencies 1(AFH) Hopping mode: Enable & Test Case 3

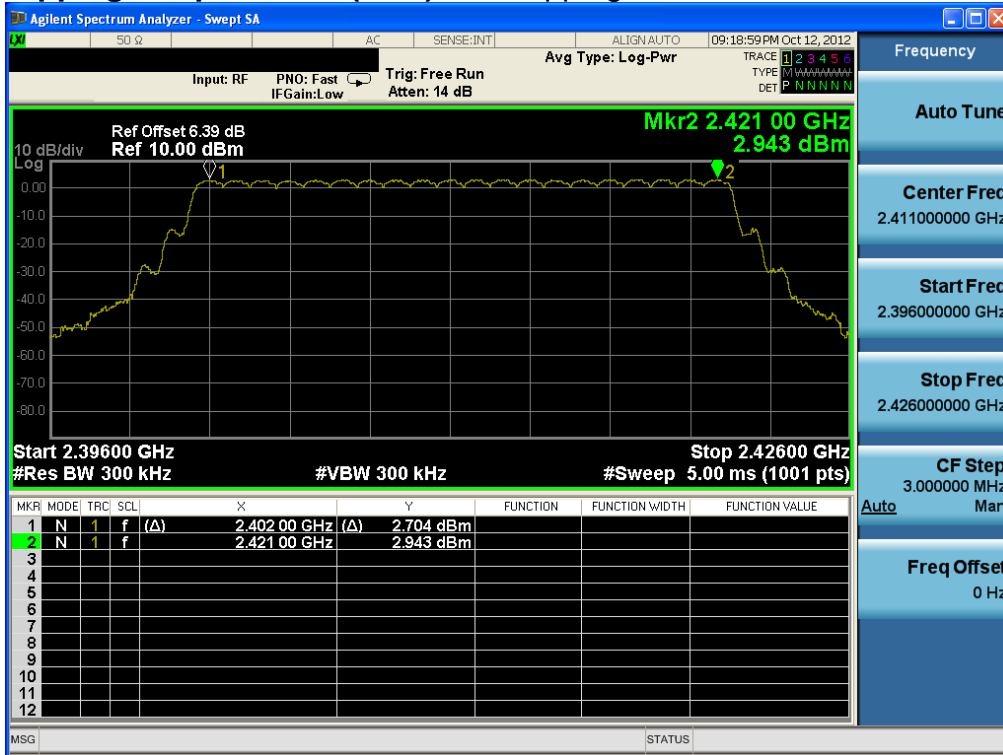

5. 20dBc BW

5.1. Test Setup

Refer to the APPENDIX I.

5.2. Limit

Limit: Not Applicable

5.3. Test Procedure

1. The 20dBc bandwidth were measured with a spectrum analyzer connected to RF antenna connector (conducted measurement) while EUT was operating in transmit mode. The analyzer center frequency was set to the EUT carrier frequency, using the analyzer.
2. The bandwidth of the fundamental frequency was measured with the spectrum analyzer using $RBW \geq 1\%$ of the 20 dB bandwidth, $VBW \geq RBW$, Span = 3MHz.

5.4. Test Results

Ambient temperature : 23°C
 Relative humidity : 50%

Modulation	Tested Channel	20dBc BW (MHz)
<u>GFSK</u>	Lowest	0.891
	Middle	0.930
	Highest	0.927
<u>$\pi/4$DQPSK</u>	Lowest	1.353
	Middle	1.341
	Highest	1.338
<u>8DPSK</u>	Lowest	1.344
	Middle	1.335
	Highest	1.335

Note 1: See next pages for actual measured spectrum plots.

20dBc Bandwidth

Lowest Channel Modulation: GFSK



20dBc Bandwidth

Middle Channel Modulation: GFSK



20dBc Bandwidth

Highest Channel Modulation: GFSK



20dBc Bandwidth

Lowest Channel Modulation: $\pi/4$ DQPSK



20dBc Bandwidth

Middle Channel & Modulation: $\pi/4$ DQPSK



20dBc Bandwidth

Highest Channel & Modulation: $\pi/4$ DQPSK



20dBc Bandwidth

Lowest Channel Modulation: **8DPSK**

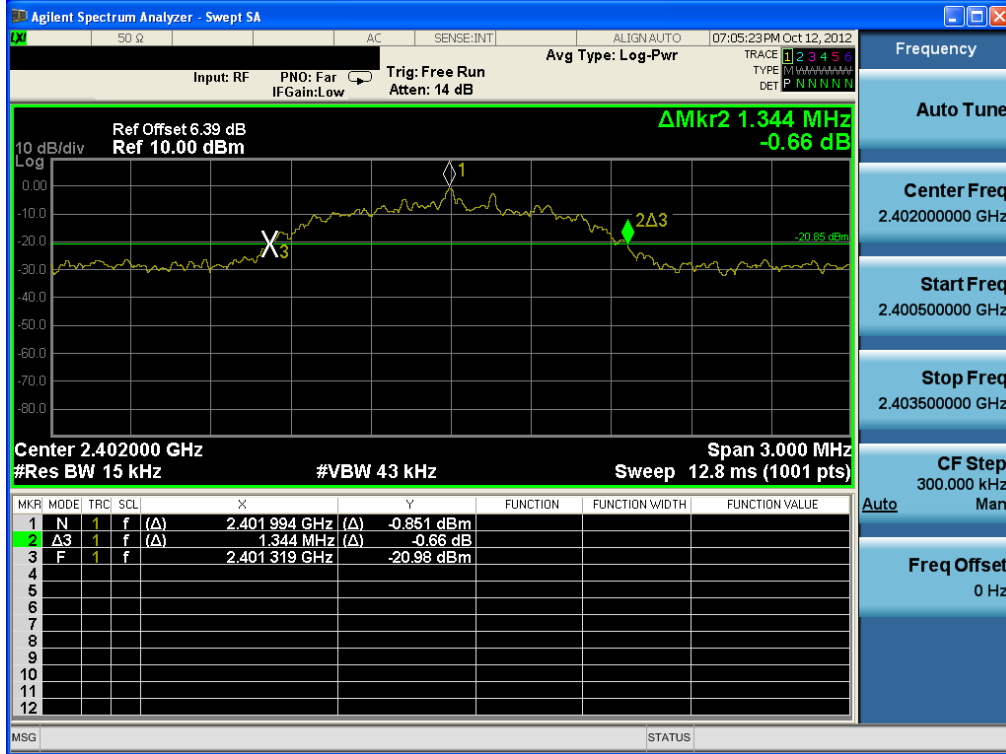

20dBc Bandwidth

Middle Channel Modulation: **8DPSK**



20dBc Bandwidth

Highest Channel Modulation: 8DPSK



6. Time of Occupancy (Dwell Time)

6.1. Test Setup

Refer to the APPENDIX I.

6.2. Limit

Limit: Not Applicable

6.3. Test Procedure

The dwell time was measured with a spectrum analyzer connected to the antenna terminal, while EUT had its hopping function enabled.

The spectrum analyzer is set to:

Center frequency = 2441, 2411 MHz

Span = zero

RBW = 1 MHz

VBW = ≥ RBW

Trace = max hold

Detector function = peak

6.4. Test Results

Ambient temperature : 23°C

Relative humidity : 50 %

- FH mode

Hopping mode	Packet Type	Number of hopping Channels	Burst On Time (ms)	Period (ms)	Test Result (s)
Enable	DH 5	79	2.880	3.750	0.307
	2 DH 5	79	2.880	3.720	0.310
	3 DH 5	79	2.880	3.750	0.307

- AFH mode

Hopping mode	Packet Type	Number of hopping Channels	Burst On Time (ms)	Period (ms)	Test Result (s)
Enable	DH 5	20	2.880	3.750	0.307
	2 DH 5	20	2.880	3.750	0.307
	3 DH 5	20	2.880	3.750	0.307

Note 1: Dwell Time = $0.4 \times \text{Hopping channel} \times \text{Burst ON time} \times ((\text{Hopping rate} \div \text{Time slots}) \div \text{Hopping channel})$

- Time slots for DH5 = 6 slots(TX = 5 slot / RX = 1 slot)

- Hopping Rate = 1600 for FH mode & 800 for AFH mode

Note 2: See next pages for actual measured spectrum plots.

Time of Occupancy (FH)

Hopping mode: Enable & Test Case 1

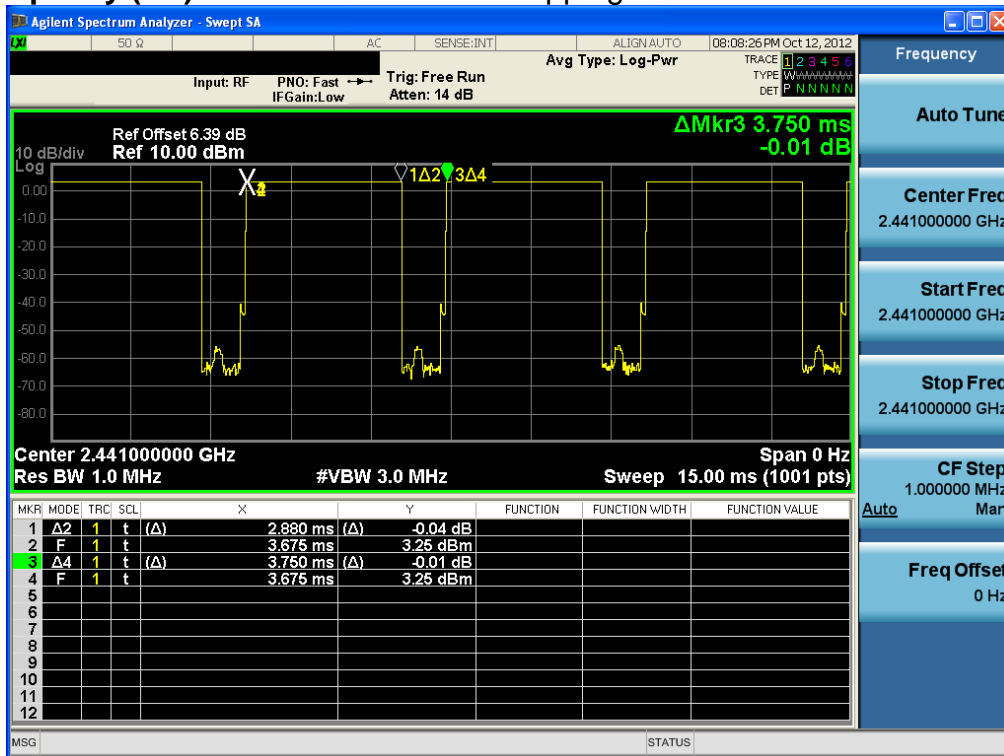

Time of Occupancy (FH)

Hopping mode: Enable & Test Case 2

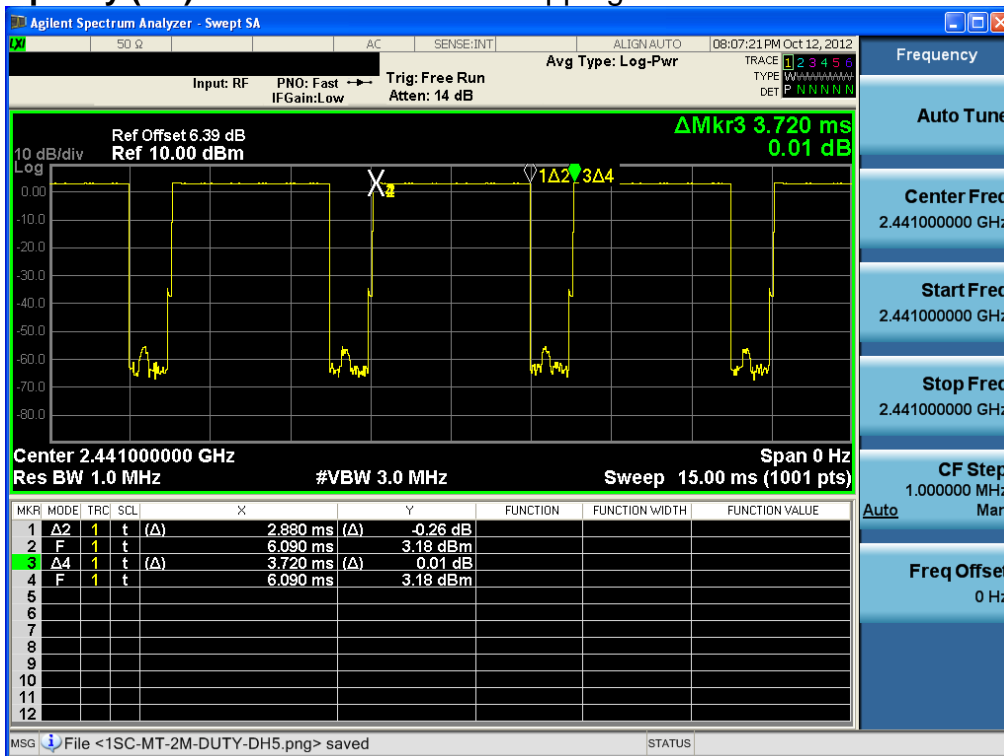

Time of Occupancy (FH)

Hopping mode: Enable & Test Case 3

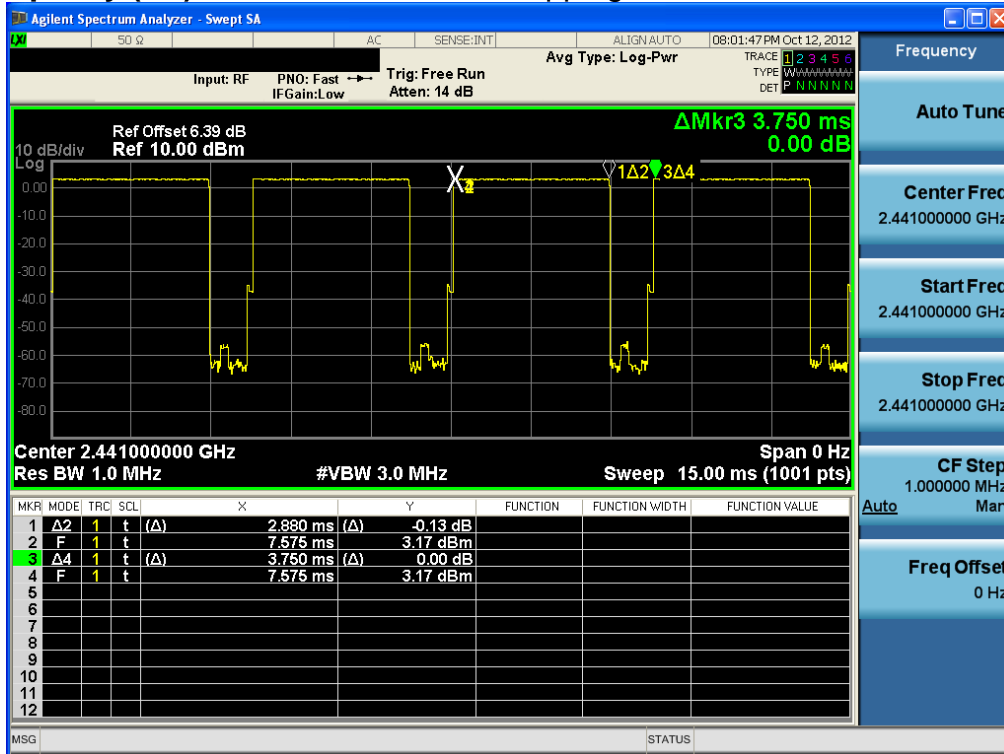

Time of Occupancy (AFH)

Hopping mode: Enable & Test Case 1

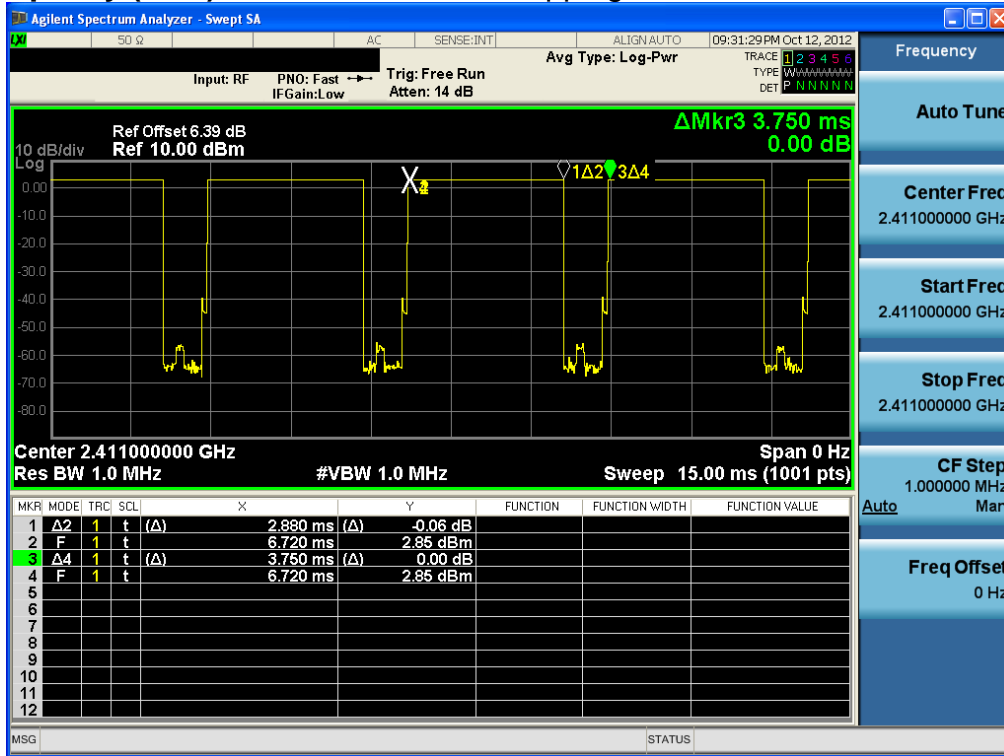

Time of Occupancy (AFH)

Hopping mode: Enable & Test Case 2

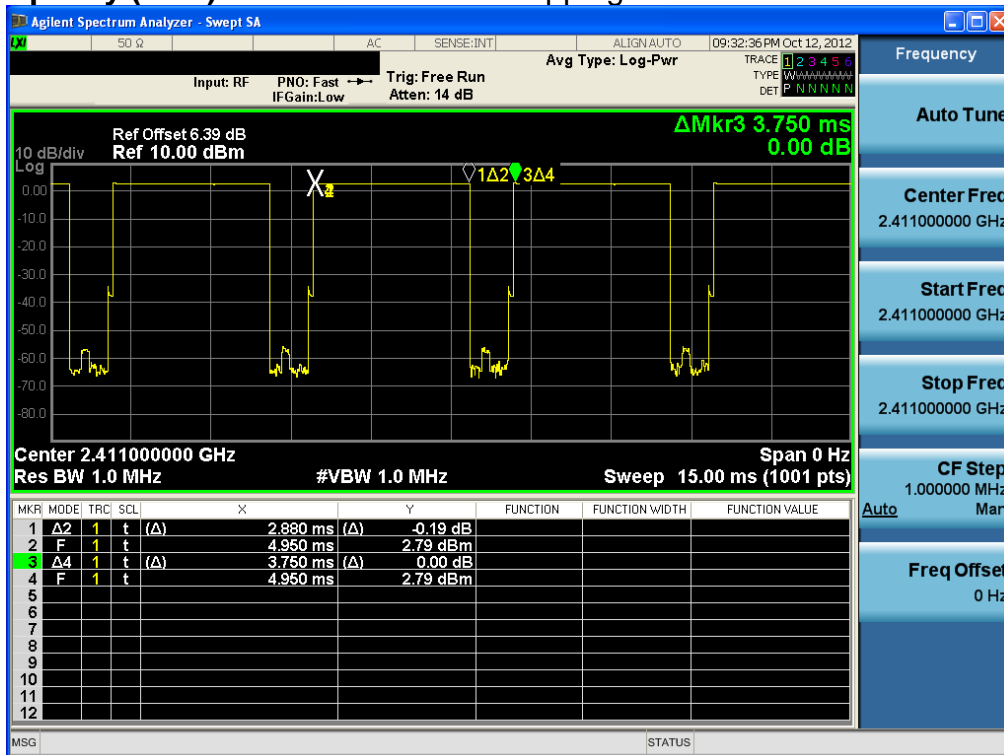

Time of Occupancy (AFH)

Hopping mode: Enable & Test Case 3

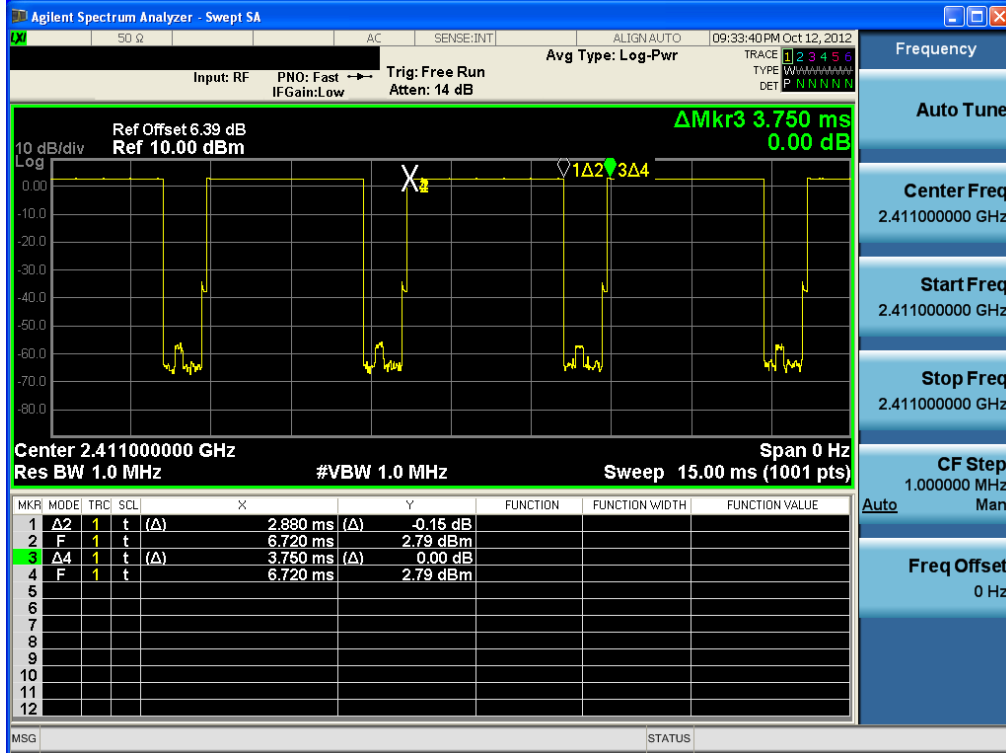

7. Maximum Peak Output Power Measurement

7.1. Test Setup

Refer to the APPENDIX I.

7.2. Limit

The maximum peak output power of the intentional radiator shall not exceed the following :

1. §15.247(a)(1), Frequency hopping systems shall have hopping channel carrier frequencies separated by a minimum of 25 kHz or the 20 dB bandwidth of the hopping channel, whichever is greater, provided the systems operate with an output power no greater than 125 mW.
2. §15.247(b)(1), For frequency hopping systems operating in the 2 400 – 2 483.5 MHz employing at least 75 non-overlapping hopping channels, and all frequency hopping systems in the 5 725 – 5 805 MHz band: 1 Watt.

7.3. Test Procedure

1. The RF power output was measured with a Spectrum analyzer connected to the RF Antenna connector (conducted measurement) while EUT was operating in transmit mode at the appropriate center frequency, A spectrum analyzer was used to record the shape of the transmit signal.
2. The bandwidth of the fundamental frequency was measured with the spectrum analyzer using ;
 Span = approximately 5 times the 20 dB bandwidth, centered on a hopping channel
 RBW ≥ 20dB BW
 VBW ≥ RBW
 Sweep = auto
 Detector function = peak
 Trace = max hold

7.4. Test Results

Ambient temperature : 23°C
 Relative humidity : 50 %

Modulation	Tested Channel	Peak Output Power	
		dBm	mW
<u>GFSK</u>	Lowest	2.789	1.901
	Middle	3.264	2.120
	Highest	2.697	1.861
<u>π/4DQPSK</u>	Lowest	2.818	1.913
	Middle	3.299	2.137
	Highest	2.718	1.870
<u>8DPSK</u>	Lowest	2.861	1.932
	Middle	3.350	2.163
	Highest	2.773	1.894

Note 1: See next pages for actual measured spectrum plots.

Peak Output Power

Lowest Channel Modulation: GFSK

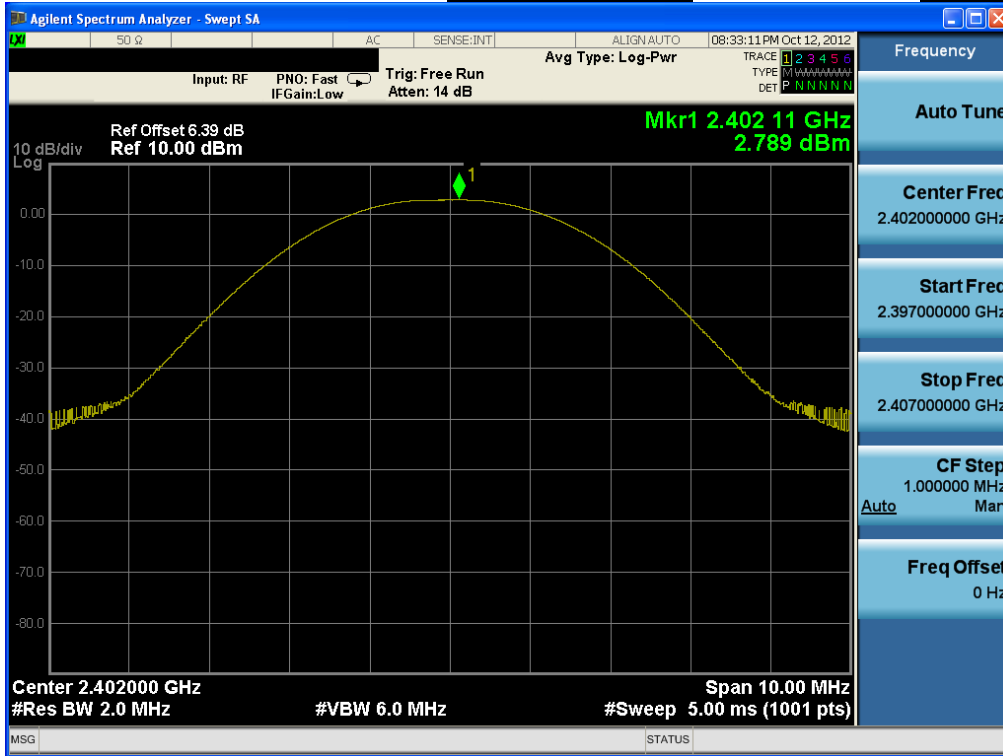

Peak Output Power

Middle Channel Modulation: GFSK

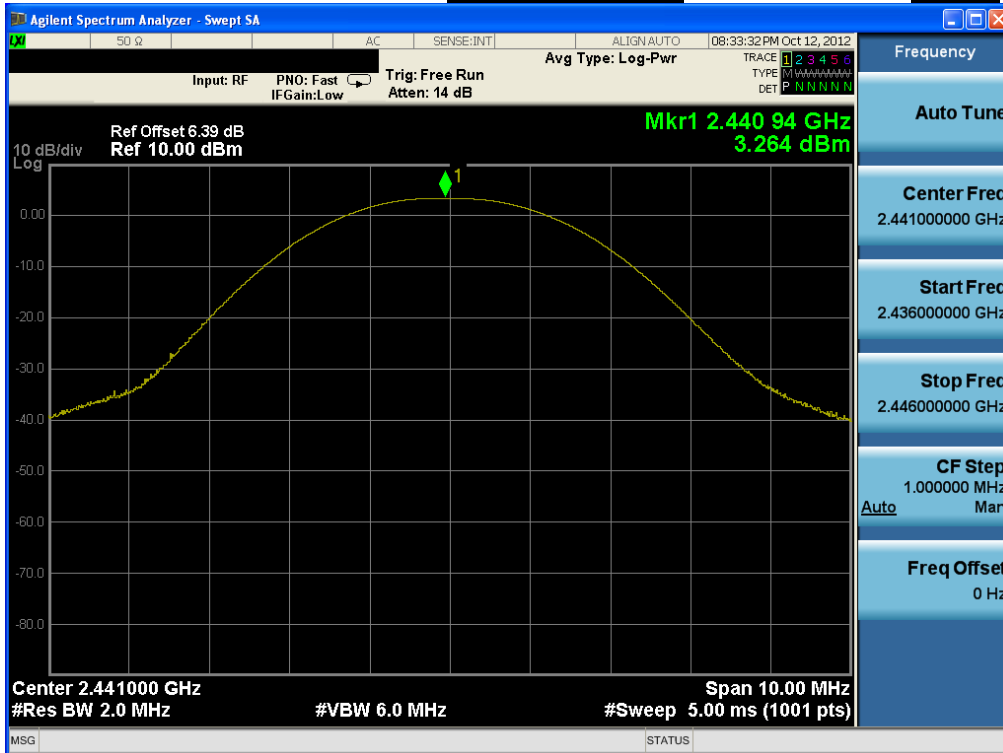

Peak Output Power

Highest Channel Modulation: GFSK

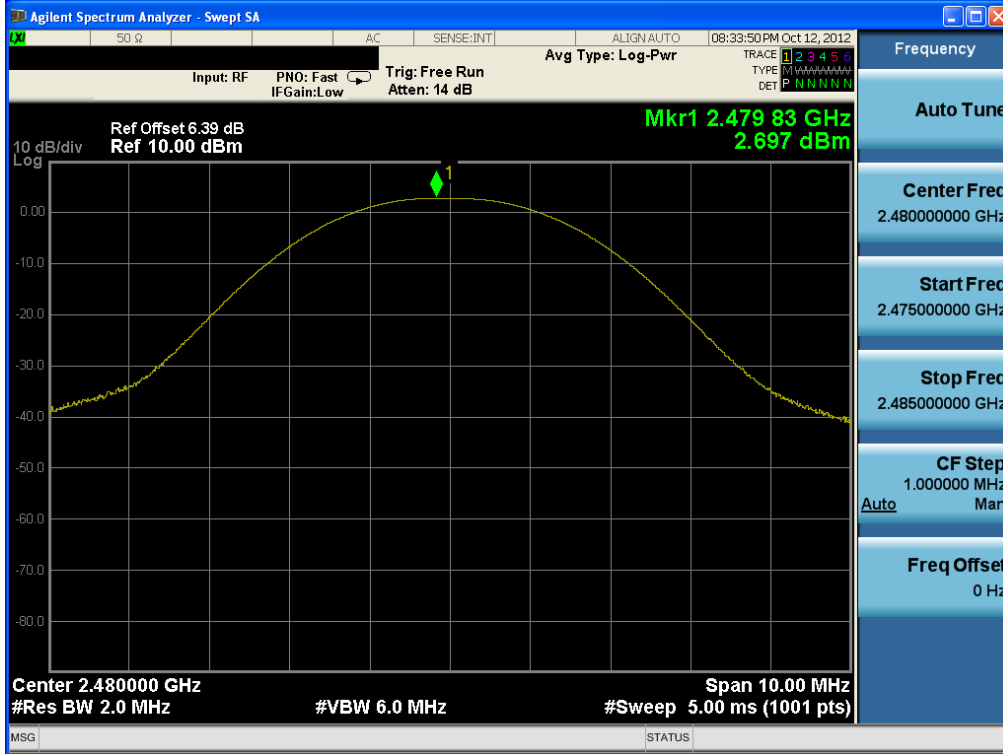

Peak Output Power

Lowest Channel Modulation: $\pi/4$ DQPSK

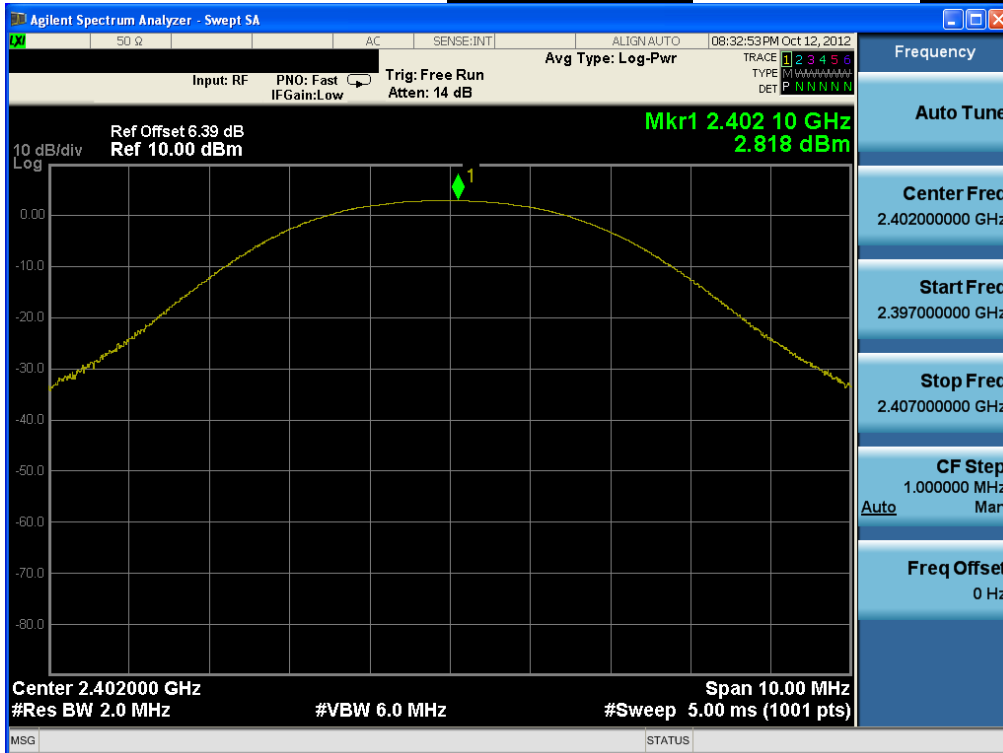

Peak Output Power

Middle Channel & Modulation: $\pi/4$ DQPSK

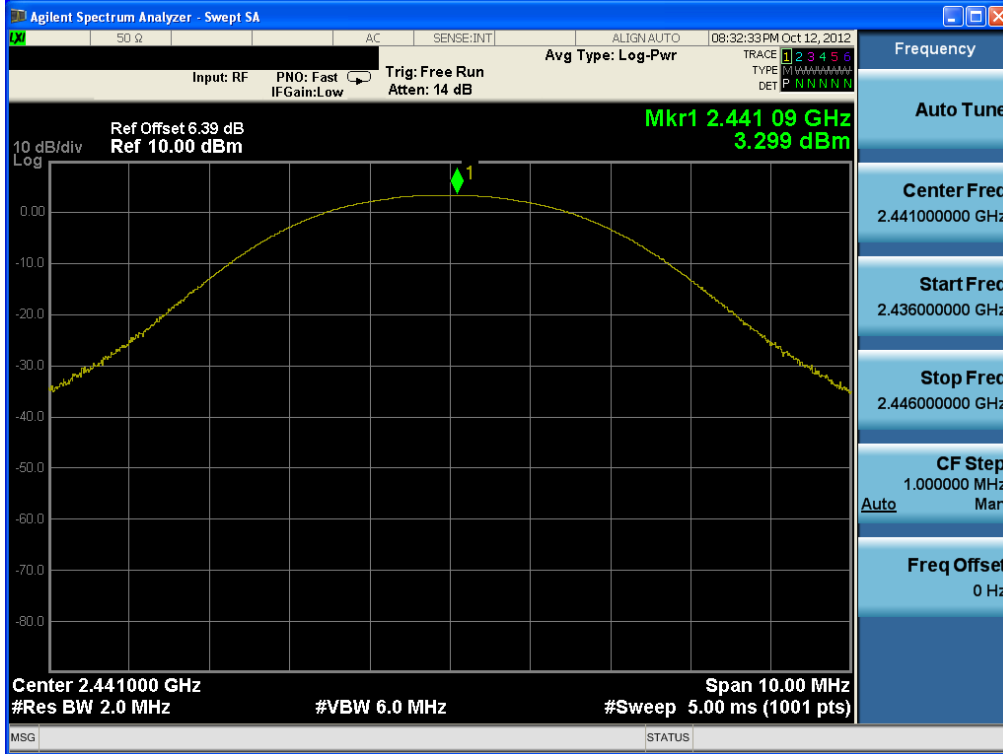

Peak Output Power

Highest Channel & Modulation: $\pi/4$ DQPSK

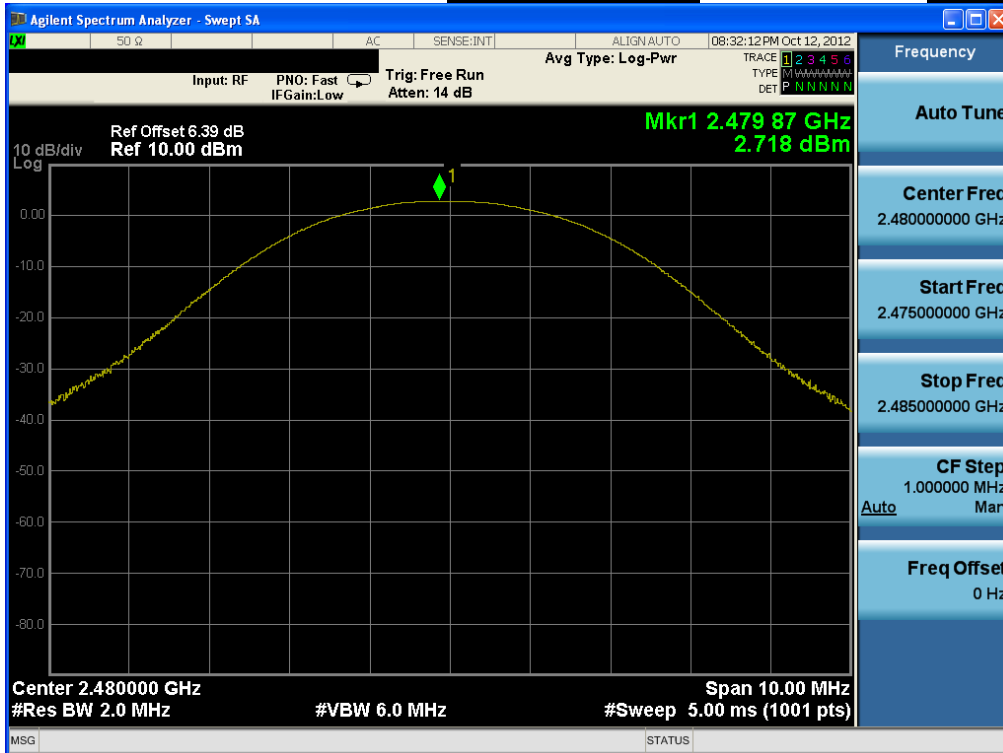

Peak Output Power

Lowest Channel Modulation: **8DPSK**

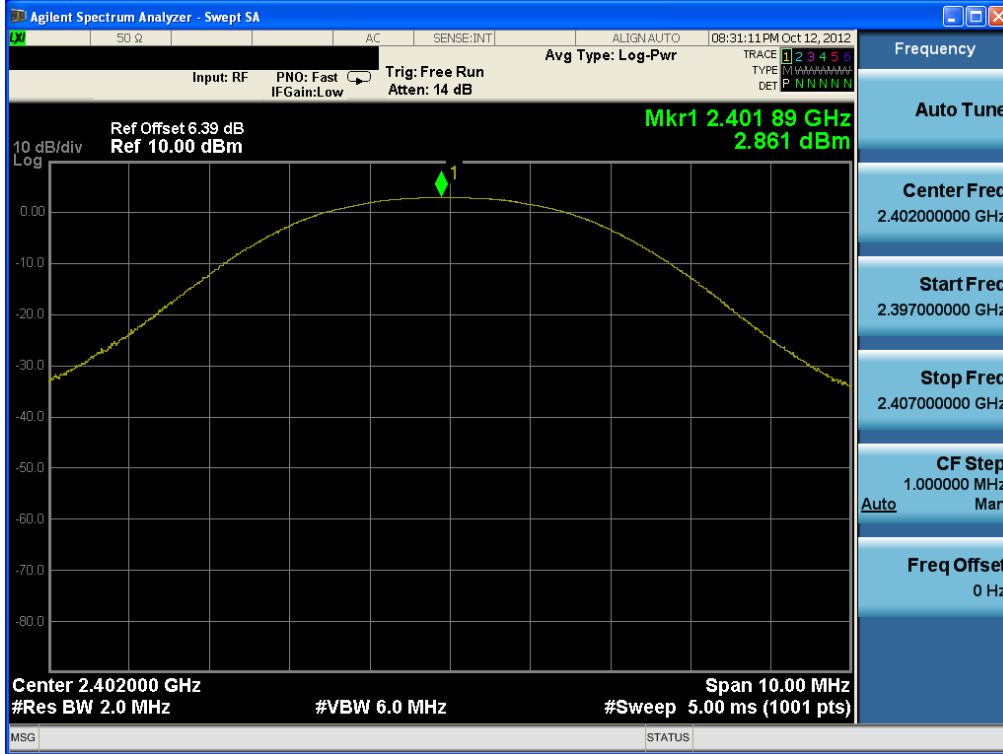

Peak Output Power

Middle Channel Modulation: **8DPSK**

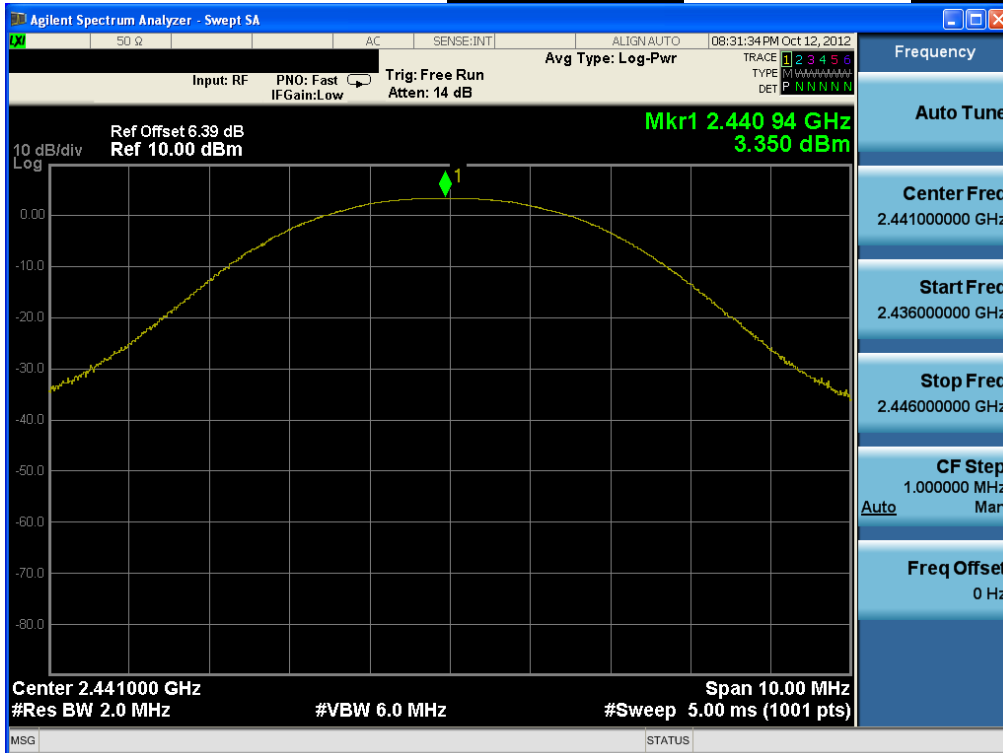

Peak Output Power

Highest Channel Modulation: **8DPSK**

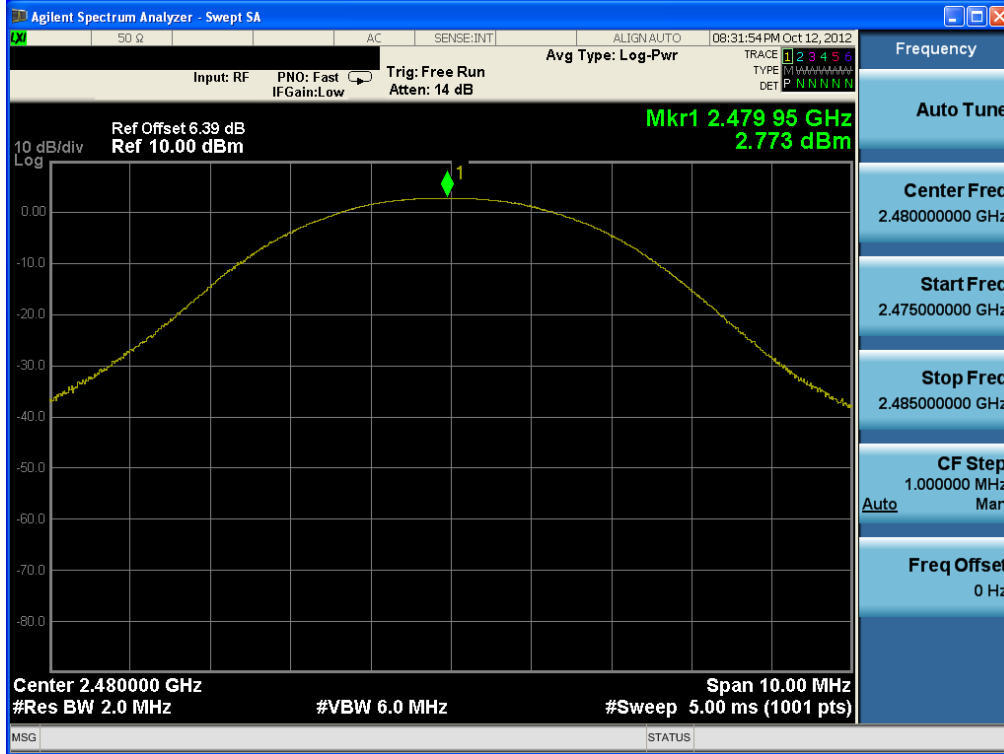

8. Transmitter AC Power Line Conducted Emission

8.1. Test Setup

Refer to test setup photo.

8.2. Limit

According to §15.207(a) for an intentional radiator that is designed to be connected to the public utility (AC) power line, the radio frequency voltage that is conducted back onto the AC power line on any frequency or frequencies, within the band 150 kHz to 30 MHz, shall not exceed the limits in the following table, as measured using a 50 uH/50 ohm line impedance stabilization network(LISN).

Compliance with the provision of this paragraph shall on the measurement of the radio frequency voltage between each power line and ground at the power terminal. The lower applies at the boundary between the frequency ranges.

Frequency Range (MHz)	Conducted Limit (dBuV)	
	Quasi-Peak	Average
0.15 ~ 0.5	66 to 56 *	56 to 46 *
0.5 ~ 5	56	46
5 ~ 30	60	50

* Decreases with the logarithm of the frequency

8.3. Test Procedures

Conducted emissions from the EUT were measured according to the dictates of ANSI C63.10-2009

1. The test procedure is performed in a 6.5 m × 3.5 m × 3.5 m (L × W × H) shielded room. The EUT along with its peripherals were placed on a 1.0 m (W) × 1.5 m (L) and 0.8 m in height wooden table and the EUT was adjusted to maintain a 0.4 meter space from a vertical reference plane.
2. The EUT was connected to power mains through a line impedance stabilization network (LISN) which provides 50 ohm coupling impedance for measuring instrument and the chassis ground was bounded to the horizontal ground plane of shielded room.
3. All peripherals were connected to the second LISN and the chassis ground also bounded to the horizontal ground plane of shielded room.
4. The excess power cable between the EUT and the LISN was bundled. The power cables of peripherals were unbundled. All connecting cables of EUT and peripherals were moved to find the maximum emission.

8.4. Test Results

AC Line Conducted Emissions (Graph)& Modulation: **GFSK**



Results of Conducted Emission

Digital EMC
 Date : 2012-11-06

Model No.	: 1SC-MT	Reference No.	:
Type	:	Power Supply	: 120 V 60 Hz
Serial No.	: NONE	Temp/Humi.	: 23°C 47% R. H.
Test Condition	: BLUETOOTH	Operator	: H.H.LEE

Memo :
 LIMIT : CISPR22_B_QP
 CISPR22_B_AV

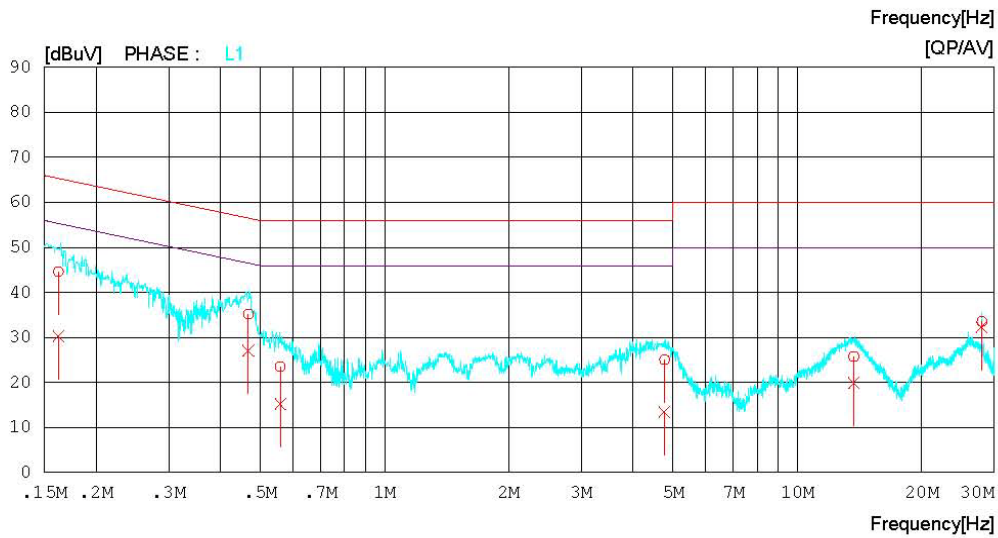
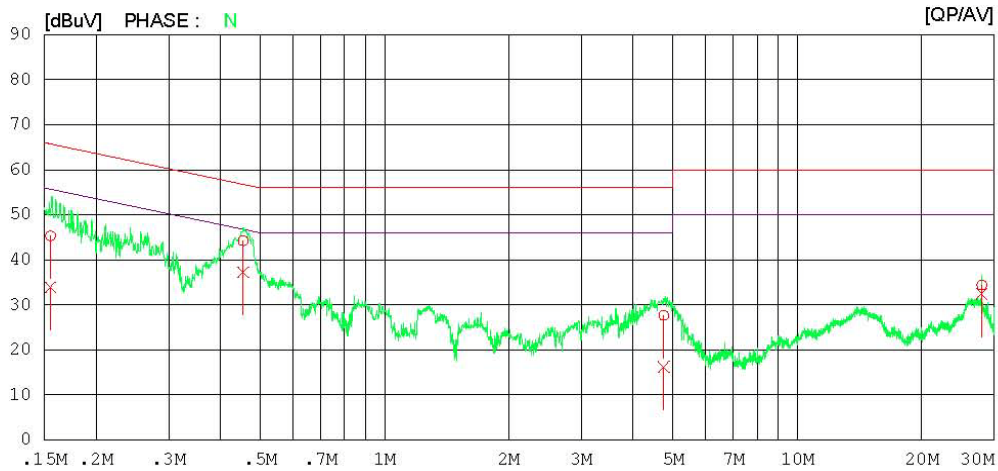

AC Line Conducted Emissions (List)& Modulation: GFSK

Results of Conducted Emission

Digital EMC
 Date : 2012-11-06

Model No.	: 1SC-MT	Reference No.	:
Type	:	Power Supply	: 120 V 60 Hz
Serial No.	: NONE	Temp/Humi.	: 23°C 47 % R. H.
Test Condition	: BLUETOOTH	Operator	: H.H.LEE

Memo :

LIMIT : CISPR22_B QP
 CISPR22_B AV

NO	FREQ [MHz]	READING		C. FACTOR [dB]	RESULT		LIMIT		MARGIN		PHASE
		QP [dBuV]	AV [dBuV]		QP [dBuV]	AV [dBuV]	QP [dBuV]	AV [dBuV]	QP [dBuV]	AV [dBuV]	
1	0.45470	44.0	37.0	0.2	44.2	37.2	56.8	46.8	12.6	9.6	N
2	4.74800	27.2	15.8	0.4	27.6	16.2	56.0	46.0	28.4	29.8	N
3	27.99900	33.4	31.5	1.0	34.4	32.5	60.0	50.0	25.6	17.5	N
4	0.15531	45.1	33.7	0.2	45.3	33.9	65.7	55.7	20.4	21.8	N
5	0.16225	44.4	30.1	0.2	44.6	30.3	65.3	55.3	20.7	25.0	L1
6	0.46796	35.0	26.9	0.2	35.2	27.1	56.6	46.6	21.4	19.5	L1
7	0.55949	23.3	15.0	0.2	23.5	15.2	56.0	46.0	32.5	30.8	L1
8	4.77150	24.6	13.1	0.4	25.0	13.5	56.0	46.0	31.0	32.5	L1
9	13.70750	25.1	19.2	0.7	25.8	19.9	60.0	50.0	34.2	30.1	L1
10	27.99750	32.5	31.3	1.0	33.5	32.3	60.0	50.0	26.5	17.7	L1

9. Antenna Requirement

9.1 Procedure

Describe how the EUT complies with the requirement that either its antenna is permanently attached, or that it employs a unique antenna connector, for every antenna proposed for use with the EUT.

9.2 Conclusion

The internal antenna (Chip antenna type) of this EUT is permanently attached on the PCB. (Refer to Internal Photo.) Therefore this device complies with the requirement.

9.3 Minimum Standard

An intentional radiator shall be designed to ensure that no antenna other than that furnished by the responsible party shall be used with the device. The use of a permanently attached antenna or of an antenna that uses a unique coupling to the intentional radiator shall be considered sufficient to comply with the provisions.

APPENDIX I

Test set up Diagrams&Path lossInformation

▪Radiated Measurement

The diagram below shows the test setup that is utilized to make the measurements for emission from 9KHz to 25GHzEmissions.

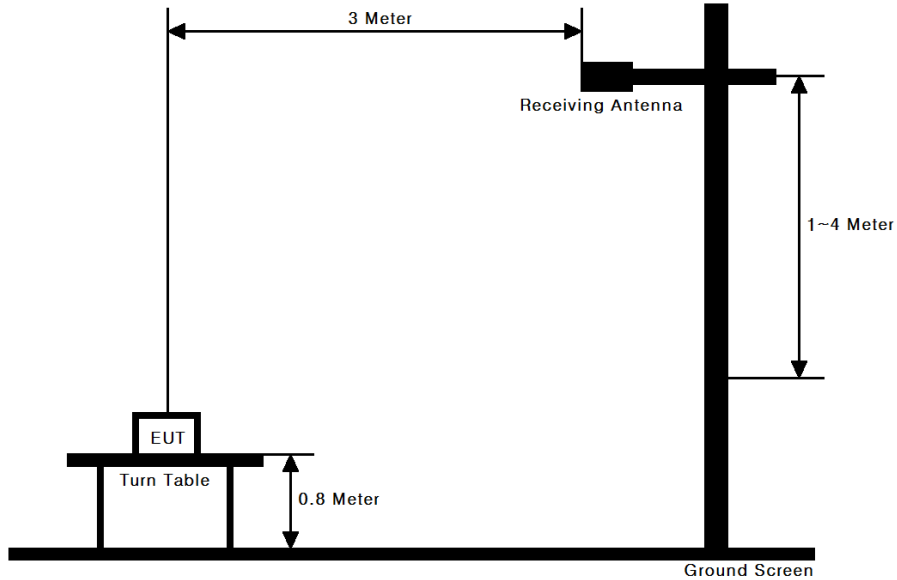

▪Conducted Measurement

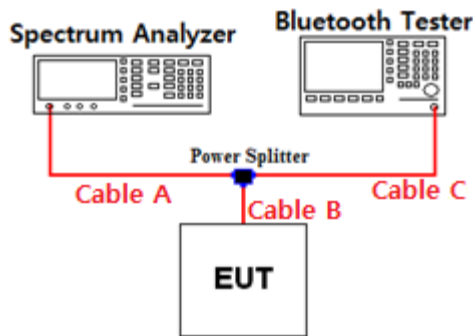

Offset value information

Frequency (GHz)	Path Loss (dB)	Frequency (GHz)	Path Loss (dB)
0.03	5.52	15	8.50
1	6.08	20	8.79
2.402 & 2.441 & 2.480	6.39	26.5	9.34
5	7.26	-	-
10	7.88	-	-

Note. 1: The path loss from EUT to Spectrum analyzer were measured and used for test.

Path loss (= S/A's Offset value) = Cable A + Power Splitter + Cable B

Note. 2: For conducted spurious emissions, the offset values were saved as the transducer factors on the spurious measurement function of the spectrum analyzer and the transducer factor of tested frequency is calculated and corrected automatically by the spectrum analyzer's measurement function.