

Prüfbericht-Nr.: <i>Test report no.:</i>	CN21ZGIE (P15C-2.4G) 001	Auftrags-Nr.: <i>Order no.:</i>	238495633	Seite 1 von 33 <i>Page 1 of 33</i>
Kunden-Referenz-Nr.: <i>Client reference no.:</i>	N/A	Auftragsdatum: <i>Order date:</i>	2020-12-23	
Auftraggeber: <i>Client:</i>	SZ DJI TECHNOLOGY CO.,LTD. , 14th floor, West Wing, Skyworth Semiconductor Design Building NO.18 Gaoxin South 4th Ave, Nanshan, Shenzhen, Guangdong, China			
Prüfgegenstand: <i>Test item:</i>	AGRAS T10			
Bezeichnung / Typ-Nr.: <i>Identification / Type no.:</i>	3WWDZ-10A			
Auftrags-Inhalt: <i>Order content:</i>	FCC Part 15C Test report (2.4GHz)			
Prüfgrundlage: <i>Test specification:</i>	FCC 47CFR Part 15: Subpart C Section 15.247			
Wareneingangsdatum: <i>Date of sample receipt:</i>	2021-01-07			
Prüfmuster-Nr.: <i>Test sample no:</i>	A002982403-015 A002982403-002			
Prüfzeitraum: <i>Testing period:</i>	2021-01-26 - 2021-04-09			
Ort der Prüfung: <i>Place of testing:</i>	EMC/RF Taipei Testing Site			
Prüflaboratorium: <i>Testing laboratory:</i>	Taipei Testing Laboratories			
Prüfergebnis*: <i>Test result*:</i>	Pass			
überprüft von: <i>reviewed by:</i>		genehmigt von: <i>authorized by:</i>		
Datum: <i>Date:</i>	2021-04-09	Ausstellungsdatum: <i>Issue date:</i>	2021-04-09	
Stellung / Position:	Senior Project Engineer	Stellung / Position:	Senior Project Manager	
Sonstiges / Other:				
Zustand des Prüfgegenstandes bei Anlieferung: <i>Condition of the test item at delivery:</i>	Prüfmuster vollständig und unbeschädigt <i>Test item complete and undamaged</i>			
* Legende:	1 = sehr gut P(ass) = entspricht o.g. Prüfgrundlage(n)	2 = gut F(ail) = entspricht nicht o.g. Prüfgrundlage(n)	3 = befriedigend N/A = nicht anwendbar	4 = ausreichend N/T = nicht getestet
* Legend:	1 = very good P(ass) = passed a.m. test specification(s)	2 = good F(ail) = failed a.m. test specification(s)	3 = satisfactory N/A = not applicable	4 = sufficient N/T = not tested
Dieser Prüfbericht bezieht sich nur auf das o.g. Prüfmuster und darf ohne Genehmigung der Prüfstelle nicht auszugsweise vervielfältigt werden. Dieser Bericht berechtigt nicht zur Verwendung eines Prüfzeichens. <i>This test report only relates to the a. m. test sample. Without permission of the test center this test report is not permitted to be duplicated in extracts. This test report does not entitle to carry any test mark.</i>				

TEST SUMMARY

Report Section	FCC Clause	Test Item	Result
5.1.1	15.247(b) & 15.203	Antenna Requirement	Pass
5.1.2	15.247(b)(3)	Output Power	Pass
5.1.3	15.247(a)(2)	6 dB Bandwidth	Pass
5.1.3	2.1049	99% Occupied Bandwidth	Pass
5.1.4	15.247(e)	Power Spectral Density	Pass
5.1.5	15.247(d)	Conducted Spurious Emissions and Band Edges	Pass
5.1.6	15.247(d) & 15.205 & 15.209	Radiated Spurious Emissions and Band Edges	Pass
-	15.207	Mains Conducted Emission	N/A (Note 1)

Note:

1. USB port is inside the enclosure and only for engineer debugging.
2. Determining compliance based on the results of the compliance measurement, not taking into account measurement instrumentation uncertainty.

Contents

HISTORY OF THIS TEST REPORT	5
1. GENERAL REMARKS	6
1.1 COMPLEMENTARY MATERIALS	6
1.2 DECISION RULE OF CONFORMITY	6
2. TEST SITES	7
2.1 TEST LABORATORY	7
2.2 TEST FACILITY	7
2.3 TRACEABILITY	8
2.4 CALIBRATION	8
2.5 MEASUREMENT UNCERTAINTY	8
3. GENERAL PRODUCT INFORMATION	9
3.1 PRODUCT FUNCTION AND INTENDED USE	9
3.2 SYSTEM DETAILS AND RATINGS	9
3.3 NOISE GENERATING AND NOISE SUPPRESSING PARTS	10
3.4 SUBMITTED DOCUMENTS	10
4. TEST SET-UP AND OPERATION MODES	11
4.1 PRINCIPLE OF CONFIGURATION SELECTION	11
4.2 CARRIER FREQUENCY AND CHANNEL	11
4.3 TEST OPERATION AND TEST SOFTWARE	14
4.4 SPECIAL ACCESSORIES AND AUXILIARY EQUIPMENT	16
4.5 TEST SETUP DIAGRAM	17
4.6 DUTY CYCLE OF TEST SIGNAL	18
5. TEST RESULTS	20
5.1 TRANSMITTER REQUIREMENT & TEST SUITES	20
5.1.1 <i>Antenna Requirement</i>	<i>20</i>
5.1.2 <i>Output Power</i>	<i>21</i>
5.1.3 <i>6 dB Bandwidth and 99% Occupied Bandwidth</i>	<i>26</i>
5.1.4 <i>Power Spectral Density</i>	<i>27</i>
5.1.5 <i>Conducted Spurious Emissions and Frequency Band Edges Measured in 100 kHz Bandwidth</i>	<i>28</i>
5.1.6 <i>Radiated Spurious Emissions and Band Edges</i>	<i>29</i>

Prüfbericht - Nr.: CN21ZGIE (P15C-2.4G) 001
Test Report No.

Seite 4 von 33
Page 4 of 33

APPENDIX A - TEST RESULT OF CONDUCTED

APPENDIX B - TEST RESULT OF RADIATED EMISSIONS

APPENDIX SP - PHOTOGRAPHS OF TEST SETUP

APPENDIX EP - PHOTOGRAPHS OF EUT

Prüfbericht- Nr.: CN21ZGIE (P15C-2.4G) 001
Test Report No.Seite 5 von 33
Page 5 of 33**HISTORY OF THIS TEST REPORT**

Report No.	Description	Date Issued
CN21ZGIE (P15C-2.4G) 001	Original Release	2021-04-09

1. General Remarks

1.1 Complementary Materials

All attachments are integral parts of this test report. This applies especially to the following appendix:

Appendix A - Test Result of Conducted

Appendix B - Test Result of Radiated Emissions

Appendix SP - Photographs of Test Setup

Appendix EP - Photographs of EUT

Applied Standard and Test Levels

Radio
FCC 47CFR Part 15: Subpart C Section 15.247
FCC 47CFR Part 2: Subpart J Section 2.1049
ANSI C63.10:2013
KDB 558074 D01 15.247 Meas Guidance v05r02

1.2 Decision Rule of Conformity

The decision rule of conformity of this test report is following the requirements of the requested standard in the quotation, and agreed among testing laboratory and manufacturer (applicant) to exclude the consideration of Measurement Uncertainty, unless it is required by the specific standard.

2. Test Sites

2.1 Test Laboratory

Taipei Testing Laboratories

11F. No.758, Sec. 4, Bade Rd., Songshan Dist.
Taipei City 105
Taiwan (R.O.C.)

2.2 Test Facility

Taipei Testing Laboratories

No.458-18, Sec. 2, Fenliao Rd., Linkou Dist.,
New Taipei City 244
Taiwan (R.O.C.)
FCC Registration No.: 226631
ISED Registration No.: 25563

2.3 Traceability

All measurement equipment calibrations are traceable to NML(Taiwan)/NIST(USA) or where calibration is performed outside Taiwan, to equivalent nationally recognized standards organizations.

2.4 Calibration

Equipment requiring calibration is calibrated periodically in a suitably accredited Calibration Lab. Additionally all equipment is verified for proper performance on a regular basis using in house standards or comparisons.

2.5 Measurement Uncertainty

All measurement uncertainty values are shown with a coverage factor of $k=2$ to indicate a 95% level of confidence.

Emission Measurement Uncertainty

Parameter	Uncertainty
Radiated Emission (9 kHz ~ 30 MHz)	± 1.15 dB
Radiated Emission (30 MHz ~ 200 MHz)	± 1.32 dB
Radiated Emission (200 MHz ~ 1 GHz)	± 1.31 dB
Radiated Emission (1 GHz ~ 18 GHz)	± 1.53 dB
Radiated Emission (18 GHz ~ 40 GHz)	± 2.50 dB
Mains Conducted Emission	± 1.65 dB

3. General Product Information

3.1 Product Function and Intended Use

The EUT is a AGRAS T10. It contains a 2.4GHz compatible module enabling the user to communicate data through a Wireless interface.

For details refer to the User Guide, Data Sheet and Circuit Diagram.

3.2 System Details and Ratings

Basic Information of EUT

Item	EUT information
Kind of Equipment/Test Item	AGRAS T10
Type Identification	3WWDZ-10A
FCC ID	SS3-T10A

Technical Specification of EUT

Item	EUT information	
Operating Frequency	1.4 MHz	2403.5 MHz ~ 2477.5 MHz
	3 MHz	2405.5 MHz ~ 2474.5 MHz
	10 MHz	2405.5 MHz ~ 2475.5 MHz
	20 MHz	2410.5 MHz ~ 2471.5 MHz
	40 MHz	2420.5 MHz ~ 2462.5 MHz
Channel Spacing	1.4 MHz	2 MHz
	3 MHz	3 MHz
	10 MHz	1 MHz
	20 MHz	1 MHz
	40 MHz	1 MHz
Channel Number	1.4 MHz	38
	3 MHz	24
	10 MHz	71
	20 MHz	62
	40 MHz	43
Operation Voltage	51.8 Vdc (Battery)	
Modulation	OFDM (BPSK, QPSK, 16QAM, 64QAM)	
Maximum Output Power (mW)	489.78	
Antenna Information	Refer to 5.1.1	
Accessory Device	Refer to 4.4	

Note: There're two antennas (Ant 0 and Ant 1) used for 2.4GHz function and supports SISO mode only.

3.3 Noise Generating and Noise Suppressing Parts

Refer to the Circuit Diagram.

3.4 Submitted Documents

- Circuit Diagram
- Instruction Manual
- Rating Label
- Technical Description

4. Test Set-up and Operation Modes

4.1 Principle of Configuration Selection

The test modes were adapted accordingly in reference to the instructions for use. During testing, Channel and Power Controlling Software provided by the customer was used to control the operating channel as well as the output power level. The RF output power selection is for the setting of RF output expected by the customer and is going to be fixed on the firmware of the final end product.

Table for Parameters of Test Software Setting

1.4 MHz		3 MHz		10 MHz		20 MHz		40 MHz	
Channel	Power Setting	Channel	Power Setting	Channel	Power Setting	Channel	Power Setting	Channel	Power Setting
2403.5	def.	2405.5	def.	2405.5	def.	2410.5	def.	2420.5	def.
2441.5	def.	2441.5	def.	2441.5	def.	2441.5	def.	2441.5	def.
2477.5	def.	2474.5	def.	2475.5	def.	2471.5	def.	2462.5	def.

4.2 Carrier Frequency and Channel

<1.4 MHz>

Channel	Frequency (MHz)	Channel	Frequency (MHz)
1	2403.5	20	2441.5
2	2405.5	21	2443.5
3	2407.5	22	2445.5
4	2409.5	23	2447.5
5	2411.5	24	2449.5
6	2413.5	25	2451.5
7	2415.5	26	2453.5
8	2417.5	27	2455.5
9	2419.5	28	2457.5
10	2421.5	29	2459.5
11	2423.5	30	2461.5
12	2425.5	31	2463.5
13	2427.5	32	2465.5
14	2429.5	33	2467.5
15	2431.5	34	2469.5
16	2433.5	35	2471.5
17	2435.5	36	2473.5
18	2437.5	37	2475.5
19	2439.5	38	2477.5

<3 MHz>

Channel	Frequency (MHz)	Channel	Frequency (MHz)
1	2405.5	13	2441.5
2	2408.5	14	2444.5
3	2411.5	15	2447.5
4	2414.5	16	2450.5
5	2417.5	17	2453.5
6	2420.5	18	2456.5
7	2423.5	19	2459.5
8	2426.5	20	2462.5
9	2429.5	21	2465.5
10	2432.5	22	2468.5
11	2435.5	23	2471.5
12	2438.5	24	2474.5

<10 MHz>

Channel	Freq. (MHz)	Channel	Freq. (MHz)	Channel	Freq. (MHz)	Channel	Freq. (MHz)
1	2405.5	21	2425.5	41	2445.5	61	2465.5
2	2406.5	22	2426.5	42	2446.5	62	2466.5
3	2407.5	23	2427.5	43	2447.5	63	2467.5
4	2408.5	24	2428.5	44	2448.5	64	2468.5
5	2409.5	25	2429.5	45	2449.5	65	2469.5
6	2410.5	26	2430.5	46	2450.5	66	2470.5
7	2411.5	27	2431.5	47	2451.5	67	2471.5
8	2412.5	28	2432.5	48	2452.5	68	2472.5
9	2413.5	29	2433.5	49	2453.5	69	2473.5
10	2414.5	30	2434.5	50	2454.5	70	2474.5
11	2415.5	31	2435.5	51	2455.5	71	2475.5
12	2416.5	32	2436.5	52	2456.5		
13	2417.5	33	2437.5	53	2457.5		
14	2418.5	34	2438.5	54	2458.5		
15	2419.5	35	2439.5	55	2459.5		
16	2420.5	36	2440.5	56	2460.5		
17	2421.5	37	2441.5	57	2461.5		
18	2422.5	38	2442.5	58	2462.5		
19	2423.5	39	2443.5	59	2463.5		
20	2424.5	40	2444.5	60	2464.5		

<20 MHz>

Channel	Freq. (MHz)	Channel	Freq. (MHz)	Channel	Freq. (MHz)	Channel	Freq. (MHz)
1	2410.5	21	2430.5	41	2450.5	61	2470.5
2	2411.5	22	2431.5	42	2451.5	62	2471.5
3	2412.5	23	2432.5	43	2452.5		
4	2413.5	24	2433.5	44	2453.5		
5	2414.5	25	2434.5	45	2454.5		
6	2415.5	26	2435.5	46	2455.5		
7	2416.5	27	2436.5	47	2456.5		
8	2417.5	28	2437.5	48	2457.5		
9	2418.5	29	2438.5	49	2458.5		
10	2419.5	30	2439.5	50	2459.5		
11	2420.5	31	2440.5	51	2460.5		
12	2421.5	32	2441.5	52	2461.5		
13	2422.5	33	2442.5	53	2462.5		
14	2423.5	34	2443.5	54	2463.5		
15	2424.5	35	2444.5	55	2464.5		
16	2425.5	36	2445.5	56	2465.5		
17	2426.5	37	2446.5	57	2466.5		
18	2427.5	38	2447.5	58	2467.5		
19	2428.5	39	2448.5	59	2468.5		
20	2429.5	40	2449.5	60	2469.5		

<40 MHz>

Channel	Freq. (MHz)	Channel	Freq. (MHz)	Channel	Freq. (MHz)
1	2420.5	16	2435.5	31	2450.5
2	2421.5	17	2436.5	32	2451.5
3	2422.5	18	2437.5	33	2452.5
4	2423.5	19	2438.5	34	2453.5
5	2424.5	20	2439.5	35	2454.5
6	2425.5	21	2440.5	36	2455.5
7	2426.5	22	2441.5	37	2456.5
8	2427.5	23	2442.5	38	2457.5
9	2428.5	24	2443.5	39	2458.5
10	2429.5	25	2444.5	40	2459.5
11	2430.5	26	2445.5	41	2460.5
12	2431.5	27	2446.5	42	2461.5
13	2432.5	28	2447.5	43	2462.5
14	2433.5	29	2448.5		
15	2434.5	30	2449.5		

4.3 Test Operation and Test Software

Setup for testing: Test samples are provided with a USB interface which makes it possible to control them through a test software installed on a notebook computer.

This software was running on the laptop computer connected to the EUT. It was used to enable the operation modes listed as below.

Test Software	DjiSdrConsole
---------------	---------------

The samples were used as follows:

A002982403-015

A002982403-002

Full test was applied on all test modes, but only worst case was shown.

After evaluated, antenna 0 was the worst case, and only antenna 0 was performed for the full tests.

EUT Configure Mode	Applicable To				Description
	Antenna Port Conducted Measurement	Radiated Spurious Emissions above 1 GHz	Radiated Spurious Emissions below 1 GHz	Mains Conducted Emission	
-	√	√	√	-	-

Note:

1. The EUT had been pre-tested on the positioned of each 3 axis. The worst case was found when position on **Y-plane**.
2. "-" means no effect.

Output Power

Pre-Scan full test was applied on all test modes, but only worst case was shown.

Following channel(s) was (were) selected for the final test as listed below.

EUT Configure Mode	Mode	Available Frequency (MHz)	Tested Frequency (MHz)
ANT 0 / ANT 1	1.4 MHz	2403.5 to 2477.5	2403.5, 2441.5, 2477.5
	3 MHz	2405.5 to 2474.5	2405.5, 2441.5, 2474.5
	10 MHz	2405.5 to 2475.5	2405.5, 2406.5, 2407.5, 2408.5, 2409.5, 2412.5, 2416.5, 2421.5, 2427.5, 2434.5, 2441.5, 2446.5, 2453.5, 2459.5, 2464.5, 2468.5, 2471.5, 2472.5, 2473.5, 2474.5, 2475.5
	20 MHz	2410.5 to 2471.5	2410.5, 2411.5, 2412.5, 2413.5, 2414.5, 2417.5, 2421.5, 2426.5, 2441.5, 2449.5, 2455.5, 2460.5, 2464.5, 2467.5, 2468.5, 2469.5, 2470.5, 2471.5
	40 MHz	2420.5 to 2462.5	2420.5, 2421.5, 2422.5, 2423.5, 2424.5, 2427.5, 2431.5, 2441.5, 2442.5, 2443.5, 2447.5, 2451.5, 2455.5, 2458.5, 2459.5, 2460.5, 2461.5, 2462.5

Conducted Bandedge

- Pre-Scan full test was applied on all test modes, but only worst case was shown.
 Following channel(s) was (were) selected for the final test as listed below.

EUT Configure Mode	Mode	Available Frequency (MHz)	Tested Frequency (MHz)
ANT 0	1.4 MHz	2403.5 to 2477.5	2403.5, 2477.5
	3 MHz	2405.5 to 2474.5	2405.5, 2474.5
	10 MHz	2405.5 to 2475.5	2405.5, 2407.5, 2408.5, 2471.5, 2472.5, 2475.5
	20 MHz	2410.5 to 2471.5	2410.5, 2413.5, 2464.5, 2470.5, 2471.5
	40 MHz	2420.5 to 2462.5	2420.5, 2421.5, 2460.5, 2462.5

Antenna Port Conducted Measurement (Other than Output power & Bandedge)

- Pre-Scan full test was applied on all test modes, but only worst case was shown.
 Following channel(s) was (were) selected for the final test as listed below.

EUT Configure Mode	Mode	Available Frequency (MHz)	Tested Frequency (MHz)
ANT 0	1.4 MHz	2403.5 to 2477.5	2403.5, 2441.5, 2477.5
	3 MHz	2405.5 to 2474.5	2405.5, 2441.5, 2474.5
	10 MHz	2405.5 to 2475.5	2405.5, 2441.5, 2475.5
	20 MHz	2410.5 to 2471.5	2410.5, 2441.5, 2471.5
	40 MHz	2420.5 to 2462.5	2420.5, 2441.5, 2462.5

Radiated Bandedge

- Pre-Scan full test was applied on all test modes, but only worst case was shown.
 Following channel(s) was (were) selected for the final test as listed below.

EUT Configure Mode	Mode	Available Frequency (MHz)	Tested Frequency (MHz)
ANT 0	1.4 MHz	2403.5 to 2477.5	2403.5, 2477.5
	3 MHz	2405.5 to 2474.5	2405.5, 2474.5
	10 MHz	2405.5 to 2475.5	2405.5, 2407.5, 2408.5, 2471.5, 2472.5, 2475.5
	20 MHz	2410.5 to 2471.5	2410.5, 2413.5, 2464.5, 2470.5, 2471.5
	40 MHz	2420.5 to 2462.5	2420.5, 2421.5, 2460.5, 2462.5
ANT 1	1.4 MHz	2403.5 to 2477.5	2477.5

Radiated Spurious Emissions (Above 1 GHz)

- Pre-Scan full test was applied on all test modes, but only worst case was shown.
 Following channel(s) was (were) selected for the final test as listed below.

EUT Configure Mode	Mode	Available Frequency (MHz)	Tested Frequency (MHz)
ANT 0	1.4 MHz	2403.5 to 2477.5	2403.5, 2441.5, 2477.5
	3 MHz	2405.5 to 2474.5	2405.5, 2441.5, 2474.5
	10 MHz	2405.5 to 2475.5	2405.5, 2441.5, 2475.5
	20 MHz	2410.5 to 2471.5	2410.5, 2441.5, 2471.5
	40 MHz	2420.5 to 2462.5	2420.5, 2441.5, 2462.5
ANT 1	1.4 MHz	2403.5 to 2477.5	2477.5

Radiated Spurious Emissions (Below 1 GHz)

- Pre-Scan full test was applied on all test modes, but only worst case was shown.
 Following channel(s) was (were) selected for the final test as listed below.

EUT Configure Mode	Mode	Available Frequency (MHz)	Tested Frequency (MHz)
ANT 0 / ANT 1	1.4 MHz	2403.5 to 2477.5	2477.5

Test Condition

Test Item	Ambient Temperature	Relative Humidity	Tested by
Conducted Measurement	22.6-24.5 °C	60-62 %	Stanislas Charles
Radiated Spurious Emissions above 1 GHz	23.9-25.9 °C	57-59 %	Eagle Tsai
Radiated Spurious Emissions below 1 GHz	23.9-25.9 °C	57-59 %	Eagle Tsai

4.4 Special Accessories and Auxiliary Equipment

The product has been tested together with the following additional accessories:

Accessory of EUT

No.	Product	Brand	Model	Description
-	Battery	DJI	BAX501-28000-51.8	51.8 Vdc, 28000 mAh
-	Battery	DJI	BAX501-9500-51.8	51.8 Vdc, 9500 mAh
-	Power Charger	DJI	AGRAS BATTERY HUB	I/P: 100-120 Vac, 15 A I/P: 200-240 Vac, 15 A
-	Power Cord (for power charger)	DJI	Power cord	1m cable
-	Remote Controller	DJI	RM500-ENT	--
-	USB Cable (for remote controller)	DJI	RM500-ENT	1 m cable
-	Adapter (for remote controller)	DJI	QC24-CN	I/P: 100-240 Vac, 0.8 A O/P: 3.6Vdc-12Vdc, 3.0 A

Support Unit

Support Unit							
No.	Description	Brand	Model	S/N	Shielded	Ferrite Core (Qty)	Length (cm)
1	Power Cable	TUV	TUV-050	N/A	NO	NO	80
2	Power Cable	TUV	TUV-049	N/A	NO	NO	120
-	Signal Cable	TUV	TUV-018	N/A	YES	NO	150
-	NoteBook	Lenovo	TP00094A	PF-1GT015	-	-	-
-	Power Supply	GWINSTEK	GPS-3303	GEU915613	-	-	-

4.5 Test Setup Diagram

<Radiated Spurious Emissions mode>

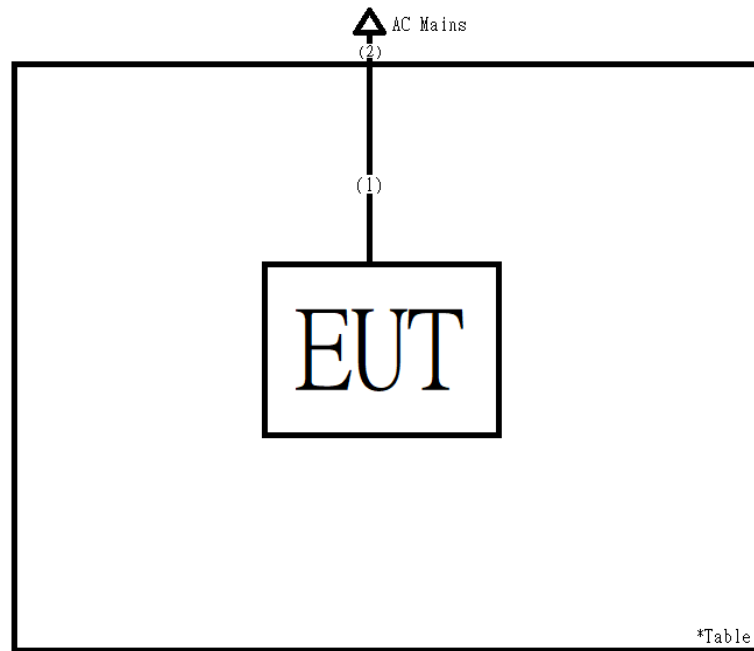

4.6 Duty Cycle of Test Signal

Mode	On + Off Time (ms)	On Time (ms)	Duty Cycle (%)	Duty Factor (dB)
1.4 MHz	1	1	100	0
3 MHz	1	1	100	0
10 MHz	1	1	100	0
20 MHz	1	1	100	0
40 MHz	1	1	100	0

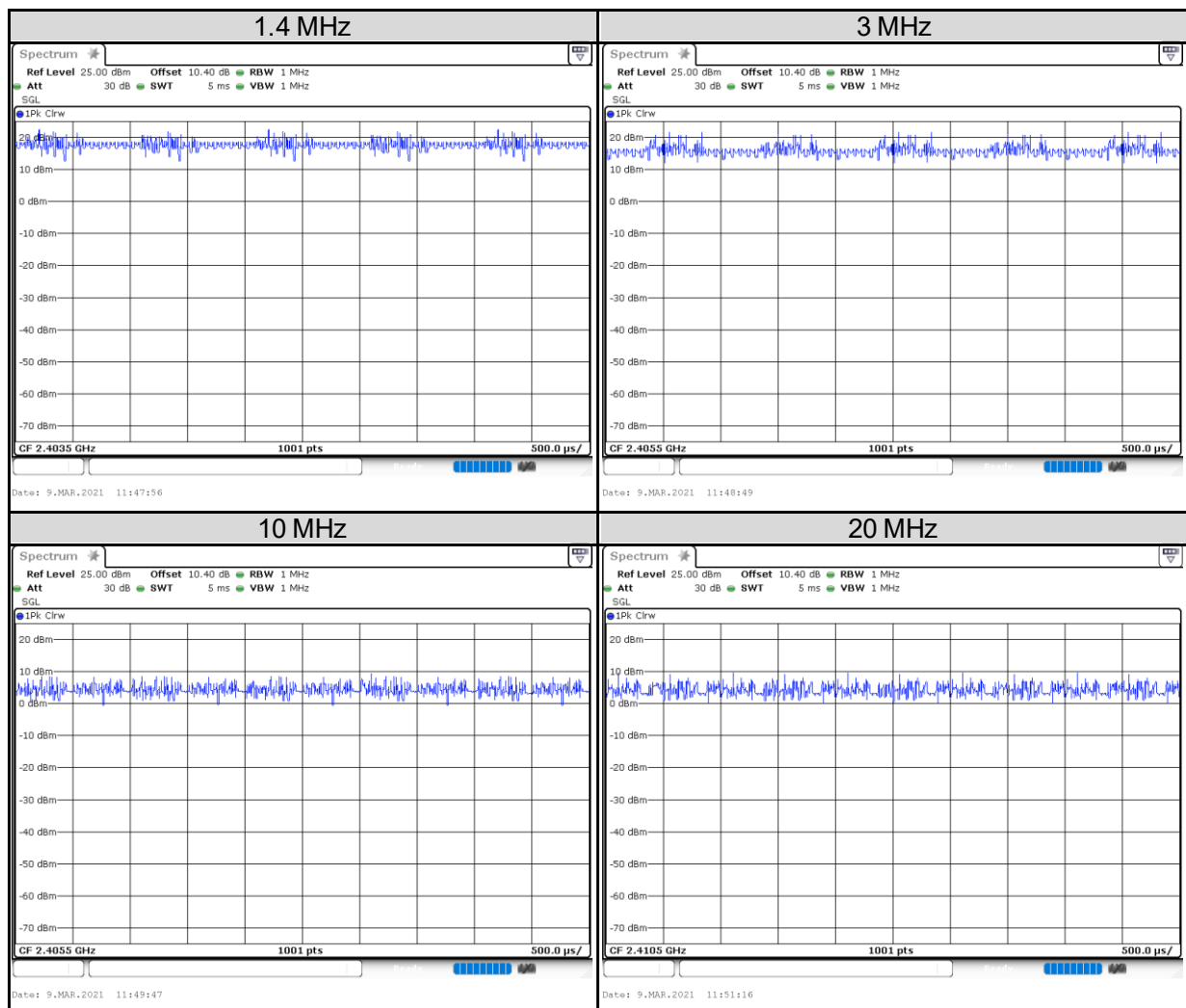

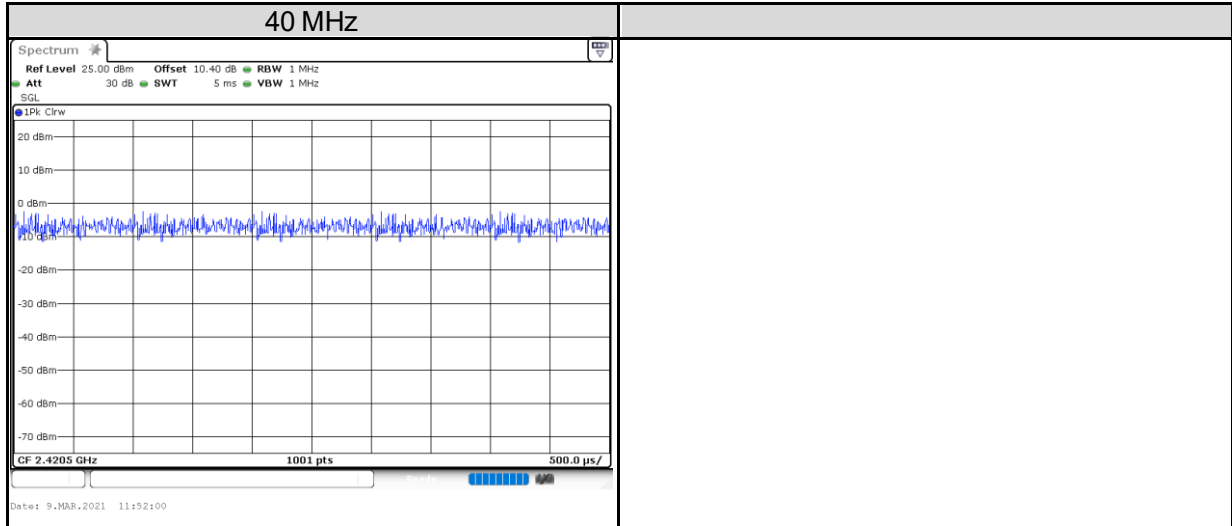

5. Test Results

5.1 Transmitter Requirement & Test Suites

5.1.1 Antenna Requirement

Requirement Use of approved antennas only

According to the manufacturer declaration, the antenna information is as listed below. The antenna is with no possibility of replacement with a non-approved antenna by the end-user. Therefore, the EUT is considered to comply with this provision.

ANT	Antenna Type	Antenna Gain (dBi)
Antenna 0	Dipole Antenna	4
Antenna 1		3

Refer to EUT photo for details.

5.1.2 Output Power

Limit 1 watt (30 dBm)

Kind of Test Site Shielded room

Test Setup

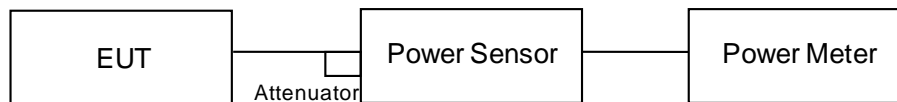

Test Instruments

Kind of Equipment	Manufacturer	Type	S/N	Calibration Date	Calibration Due Date	Test Date	
						From	Until
Power Meter	Anritsu	ML2495A	1901008	2020/4/6	2021/4/5	2021/2/24	2021/4/9
				2021/3/24	2022/3/23		
Power Sensor	Anritsu	MA2411B	1725269	2020/4/7	2021/4/6	2021/2/24	2021/4/9
				2021/3/24	2022/3/23		

Test Procedures

Average power sensor was used to perform output power measurement, trigger and gating function of wide band power meter is enabled to measure max output power of TX on burst. Duty factor is not added to measured value.

Test Result
Average Power
<1.4 MHz>

ANT	Channel Frequency (MHz)	Average Power		Limit (dBm)
		(dBm)	(mW)	
ANT 0	2403.5	15.94	39.26	30
	2441.5	15.56	35.97	30
	2477.5	16.24	42.07	30
ANT 1	2403.5	16.28	42.46	30
	2441.5	17.24	52.97	30
	2477.5	16.77	47.53	30

<3 MHz>

ANT	Channel Frequency (MHz)	Average Power		Limit (dBm)
		(dBm)	(mW)	
ANT 0	2405.5	15.94	39.26	30
	2441.5	16.06	40.36	30
	2474.5	16.39	43.55	30
ANT 1	2405.5	16.46	44.26	30
	2441.5	17.26	53.21	30
	2474.5	17.12	51.52	30

<10 MHz>

ANT	Channel Frequency (MHz)	Average Power		Limit (dBm)
		(dBm)	(mW)	
ANT 0	2405.5	9.86	9.68	30
	2406.5	10.68	11.69	30
	2407.5	12.69	18.58	30
	2408.5	13.68	23.33	30
	2409.5	14.64	29.11	30
	2412.5	15.74	37.50	30
	2416.5	17.72	59.16	30
	2421.5	20.86	121.90	30
	2427.5	23.65	231.74	30
	2434.5	25.57	360.58	30
	2441.5	25.87	386.37	30
	2446.5	26.13	410.20	30
	2453.5	20.99	125.60	30
	2459.5	17.99	62.95	30
	2464.5	16.11	40.83	30
	2468.5	14.04	25.35	30
	2471.5	11.99	15.81	30
	2472.5	10.41	10.99	30
	2473.5	4.54	2.84	30
	2474.5	4.46	2.79	30
2475.5	4.41	2.76	30	
ANT 1	2405.5	10.44	11.07	30
	2406.5	12.23	16.71	30
	2407.5	13.25	21.13	30
	2408.5	14.26	26.67	30
	2409.5	15.27	33.65	30
	2412.5	16.29	42.56	30
	2416.5	18.19	65.92	30
	2421.5	21.20	131.83	30
	2427.5	24.43	277.33	30
	2434.5	25.88	387.26	30
	2441.5	26.90	489.78	30
	2446.5	26.44	440.55	30
	2453.5	21.92	155.60	30
	2459.5	18.70	74.13	30
	2464.5	16.34	43.05	30
	2468.5	14.54	28.44	30
	2471.5	12.52	17.86	30
	2472.5	10.00	10.00	30
	2473.5	4.09	2.56	30
	2474.5	4.04	2.54	30
2475.5	4.62	2.90	30	

<20 MHz>

ANT	Channel Frequency (MHz)	Average Power		Limit (dBm)
		(dBm)	(mW)	
ANT 0	2410.5	12.89	19.45	30
	2411.5	12.56	18.03	30
	2412.5	13.57	22.75	30
	2413.5	14.60	28.84	30
	2414.5	15.61	36.39	30
	2417.5	18.56	71.78	30
	2421.5	20.67	116.68	30
	2426.5	21.28	134.28	30
	2441.5	22.81	190.99	30
	2449.5	22.05	160.32	30
	2455.5	18.90	77.62	30
	2460.5	13.55	22.65	30
	2464.5	11.54	14.26	30
	2467.5	9.97	9.93	30
	2468.5	9.95	9.89	30
	2469.5	9.91	9.79	30
	2470.5	9.90	9.77	30
2471.5	4.41	2.76	30	
ANT 1	2410.5	13.34	21.58	30
	2411.5	13.01	20.00	30
	2412.5	14.01	25.18	30
	2413.5	15.01	31.70	30
	2414.5	16.01	39.90	30
	2417.5	18.93	78.16	30
	2421.5	20.91	123.31	30
	2426.5	22.20	165.96	30
	2441.5	23.65	231.74	30
	2449.5	22.39	173.38	30
	2455.5	19.54	89.95	30
	2460.5	14.69	29.44	30
	2464.5	12.25	16.79	30
	2467.5	11.25	13.34	30
	2468.5	9.74	9.42	30
	2469.5	9.74	9.42	30
	2470.5	9.70	9.33	30
2471.5	4.51	2.82	30	

<40 MHz>

ANT	Channel Frequency (MHz)	Average Power		Limit (dBm)
		(dBm)	(mW)	
ANT 0	2420.5	4.06	2.55	30
	2421.5	9.83	9.62	30
	2422.5	9.86	9.68	30
	2423.5	9.85	9.66	30
	2424.5	9.87	9.71	30
	2427.5	9.91	9.79	30
	2431.5	12.93	19.63	30
	2441.5	13.57	22.75	30
	2442.5	12.37	17.26	30
	2443.5	11.36	13.68	30
	2447.5	9.85	9.66	30
	2451.5	9.81	9.57	30
	2455.5	9.78	9.51	30
	2458.5	9.74	9.42	30
	2459.5	9.70	9.33	30
	2460.5	9.68	9.29	30
	2461.5	3.47	2.22	30
2462.5	4.01	2.52	30	
ANT 1	2420.5	4.34	2.72	30
	2421.5	9.85	9.66	30
	2422.5	9.87	9.71	30
	2423.5	9.89	9.75	30
	2424.5	9.91	9.79	30
	2427.5	9.93	9.84	30
	2431.5	13.96	24.89	30
	2441.5	14.24	26.55	30
	2442.5	12.91	19.54	30
	2443.5	11.91	15.52	30
	2447.5	9.88	9.73	30
	2451.5	9.83	9.62	30
	2455.5	9.78	9.51	30
	2458.5	9.73	9.40	30
	2459.5	9.68	9.29	30
2460.5	9.65	9.23	30	
2461.5	3.44	2.21	30	
2462.5	4.07	2.55	30	

5.1.3 6 dB Bandwidth and 99% Occupied Bandwidth

Limit The minimum 6 dB bandwidth shall be at least 500 kHz.

Kind of Test Site Shielded room

Test Setup

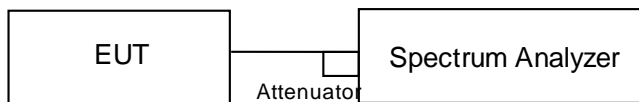

Test Instruments

Kind of Equipment	Manufacturer	Type	S/N	Calibration Date	Calibration Due Date	Test Date	
						From	Until
Spectrum Analyzer	R&S	FSV40	101512	2020/2/18	2021/2/16	2021/1/26	2021/3/9
				2021/1/29	2022/1/28		

Test Procedure

- Set resolution bandwidth (RBW) = 100 kHz
- Set the video bandwidth (VBW) $\geq 3 \times$ RBW, Detector = Peak.
- Trace mode = max hold.
- Sweep = auto couple.
- Measure the maximum width of the emission that is constrained by the frequencies associated with the two amplitude points (upper and lower) that are attenuated by 6 dB relative to the maximum level measured in the fundamental emission.
- For 99% occupied bandwidth measurement, the transmitter output was connected to the spectrum analyzer through an attenuator. The bandwidth of the fundamental frequency was measured by spectrum analyzer with resolution bandwidth in the range of 1% to 5% of the anticipated emission bandwidth, and a video bandwidth at least 3x the resolution bandwidth and set the detector to PEAK. The width of a frequency band such that, below the lower and above the upper frequency limits, the mean powers emitted are each equal to a specified percentage 0.5% of the total mean power of a given emission.

Test Results

Please refer to Appendix A.

5.1.4 Power Spectral Density

Limit

The power spectral density shall not be greater than 8 dBm in any 3 kHz band.

Kind of Test Site Shielded room

Test Setup

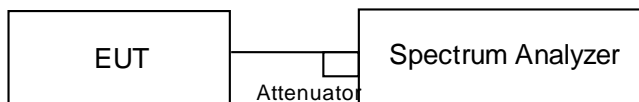

Test Instruments

Kind of Equipment	Manufacturer	Type	S/N	Calibration Date	Calibration Due Date	Test Date	
						From	Until
Spectrum Analyzer	R&S	FSV40	101512	2020/2/18	2021/2/16	2021/1/26	2021/3/9
				2021/1/29	2022/1/28		

Test Procedure

- a. Set analyzer center frequency to DTS channel center frequency.
- b. Set the span to 1.5 times the DTS bandwidth.
- c. Set the RBW to: $3 \text{ kHz} \leq \text{RBW} \leq 100 \text{ kHz}$.
- d. Set the VBW $\geq 3 \times \text{RBW}$.
- e. Detector = peak.
- f. Sweep time = auto couple.
- g. Trace mode = max hold.
- h. Allow trace to fully stabilize.
- i. Use the peak marker function to determine the maximum amplitude level within the RBW.

Test Results

Please refer to Appendix A.

5.1.5 Conducted Spurious Emissions and Frequency Band Edges Measured in 100 kHz Bandwidth

Limit

30 dB (below that in the 100 kHz bandwidth within the band that contains the highest level of the desired power.)

Kind of Test Site Shielded room

Test Setup

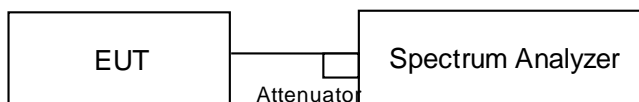

Test Instruments

Kind of Equipment	Manufacturer	Type	S/N	Calibration Date	Calibration Due Date	Test Date	
						From	Until
Spectrum Analyzer	R&S	FSV40	101512	2020/2/18	2021/2/16	2021/1/26	2021/4/9
				2021/1/29	2022/1/28		

Test Procedure

Measurement procedure REF

1. Set the RBW = 100 kHz.
2. Set the VBW \geq 300 kHz.
3. Detector = peak.
4. Sweep time = auto couple.
5. Trace mode = max hold.
6. Allow trace to fully stabilize.
7. Use the peak marker function to determine the maximum power level in any 100 kHz band segment within the fundamental EBW.

Measurement procedure OOBE

1. Set RBW = 100 kHz.
2. Set VBW \geq 300 kHz.
3. Detector = peak.
4. Sweep = auto couple.
5. Trace Mode = max hold.
6. Allow trace to fully stabilize.
7. Use the peak marker function to determine the maximum amplitude level.

Test Results

Please refer to Appendix A.

5.1.6 Radiated Spurious Emissions and Band Edges

Limit

Radiated emissions which fall in the restricted bands, as defined in §15.205(a), must comply with the radiated emission limits specified in §15.209(a).

Emissions radiated outside the restricted and authorized frequency bands must either comply with the radiated emission limits specified for the restricted bands or in §15.247(d).

Kind of Test Site 3m Semi-Anechoic Chamber

Test Setup

<Radiated Emissions below 30 MHz>

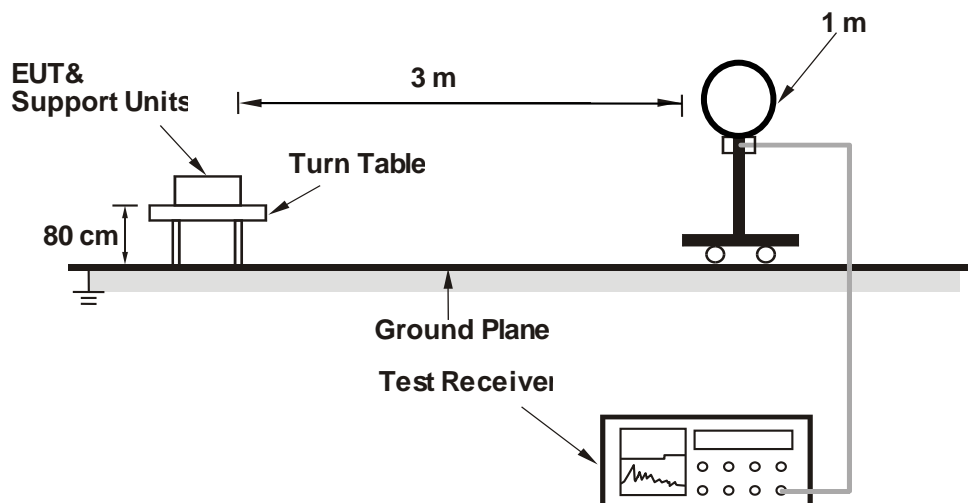

<Radiated Emissions 30 MHz to 1 GHz>

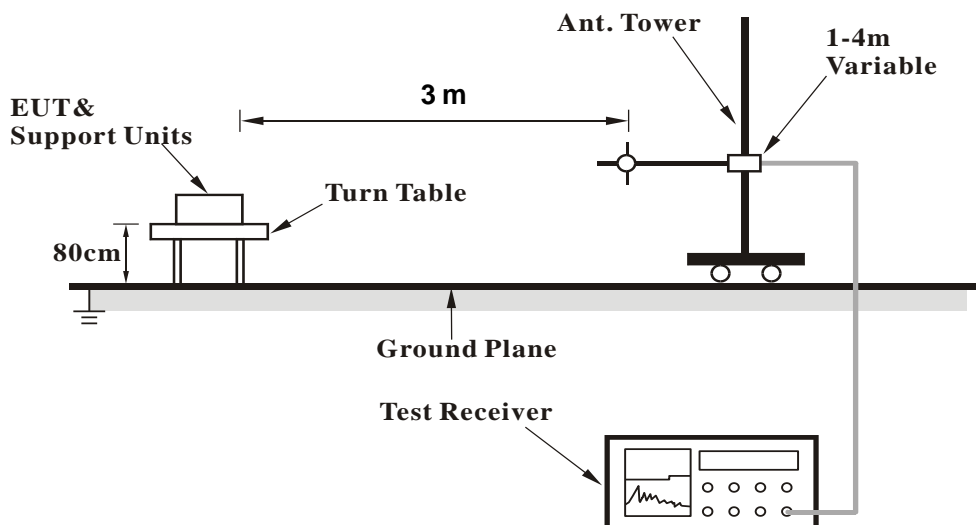

<Radiated Emissions above 1 GHz>

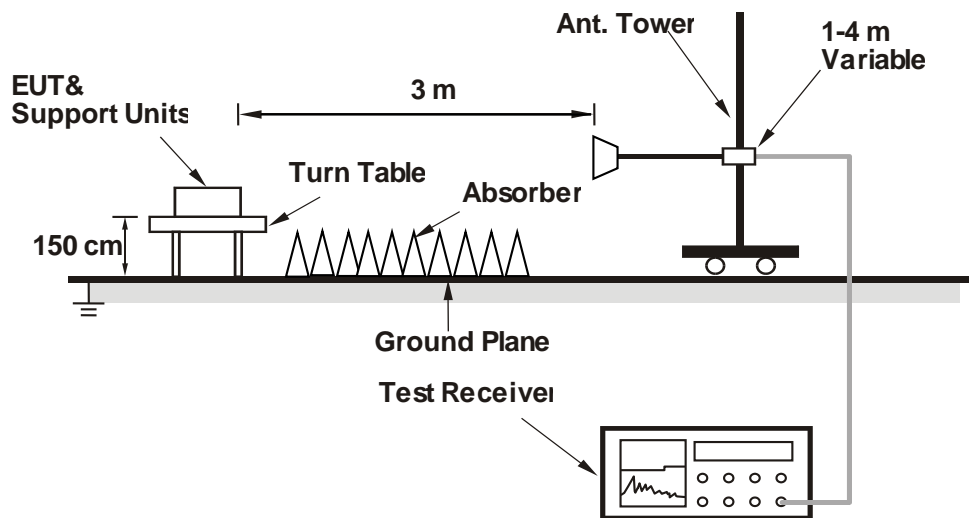

For the actual test configuration, please refer to the attached file (Test Setup Photo).

Test Instruments

Test Date: 2021-03-05 ~ 2021-04-09

Kind of Equipment	Manufacturer	Type	S/N	Calibration Date	Calibration Due Date
Signal Analyzer	R&S	FSV40	101509	2020/5/5	2021/5/4
Receiver	R&S	ESR7	102109	2020/3/30	2021/3/29
Receiver	R&S	ESR7	102109	2021/04/06	2022/04/05
Bilog Antenna	SCHWARZBECK	VULB-9168	00950	2021/1/25	2022/1/24
Horn Antenna	ETS-Lindgren	3117	00218929	2020/11/6	2021/11/5
LF-AMP	Agilent	8447D	2727A05146	2021/2/1	2022/1/31
HF-AMP + AC source	EMCI	EMC051845SE	980635	2021/2/1	2022/1/31
HF-AMP + AC source	EMCI	EMC184045SE	980656	2021/2/9	2022/2/8
Horn Antenna	SCHWARZBECK	BBHA 9170	00890	2020/4/13	2021/4/12
Microwave Cable	HUBER+SUHNER	SUCOFLEX 104EA	800057/4EA	2020/4/22	2021/4/21
Microwave Cable	HUBER+SUHNER	SUCOFLEX 104	802244/4	2020/4/22	2021/4/21
Microwave Cable	HUBER+SUHNER	SUCOFLEX 104	MY37203/4	2020/4/22	2021/4/21
Microwave Cable	HUBER+SUHNER	SUCOFLEX 102EA	800897/2EA	2020/3/25	2021/3/24
Microwave Cable	HUBER+SUHNER	SUCOFLEX 102EA	800897/2EA	2021/03/23	2022/03/22
Microwave Cable	HUBER+SUHNER	SUCOFLEX 102EA	800902/2EA	2020/3/25	2021/3/24
Microwave Cable	HUBER+SUHNER	SUCOFLEX 102EA	800902/2EA	2021/03/23	2022/03/22
Microwave Cable	HUBER+SUHNER	SUCOFLEX 102EA	801026/2EA	2020/3/25	2021/3/24
Microwave Cable	HUBER+SUHNER	SUCOFLEX 102EA	801026/2EA	2021/03/23	2022/03/22
Loop Antenna	Chance Most	EMCILPA600 +calibration	287	2021/1/18	2022/1/17

Test Procedures**For Radiated Emissions below 30 MHz**

- a. The EUT was placed on the top of a rotating table 0.8 meters above the ground at a 3 meter chamber room. The table was rotated 360 degrees to determine the position of the highest radiation.
- b. The EUT was set 3 meters away from the interference-receiving antenna, which was mounted on the top of a variable-height antenna tower.
- c. Parallel (OPEN), perpendicular (CLOSE), and ground-parallel (GROUND) orientations of the antenna are set to make the measurement.
- d. For each suspected emission, the EUT was arranged to its worst case and the rotatable table was turned from 0 degrees to 360 degrees to find the maximum reading.
- e. The test-receiver system was set to Quasi-Peak Detect Function and Specified Bandwidth with Maximum Hold Mode.

Note:

1. The resolution bandwidth and video bandwidth of test receiver/spectrum analyzer is 9 kHz at frequency below 30 MHz.
2. All modes of operation were investigated and the worst-case emissions are reported.

For Radiated Emissions above 30 MHz

- a. The EUT was placed on the top of a rotating table 0.8 meters (for 30 MHz ~ 1 GHz) / 1.5 meters (for above 1 GHz) above the ground at 3 meter chamber room for test. The table was rotated 360 degrees to determine the position of the highest radiation.
- b. The EUT was set 3 meters away from the interference-receiving antenna, which was mounted on the top of a variable-height antenna tower.
- c. The height of antenna is varied from one meter to four meters above the ground to determine the maximum value of the field strength. Both horizontal and vertical polarizations of the antenna are set to make the measurement.
- d. For each suspected emission, the EUT was arranged to its worst case and then the antenna was tuned to heights from 1 meter to 4 meters and the rotatable table was turned from 0 degrees to 360 degrees to find the maximum reading.
- e. The test-receiver system was set to quasi-peak detect function and specified bandwidth with maximum hold mode when the test frequency is below 1 GHz.
- f. The test-receiver system was set to peak and average detected function and specified bandwidth with maximum hold mode when the test frequency is above 1 GHz. If the peak reading value also meets average limit, measurement with the average detector is unnecessary.

Note:

1. The resolution bandwidth and video bandwidth of test receiver/spectrum analyzer is 120 kHz for Quasi-peak detection (QP) or Peak detection (PK) at frequency below 1 GHz.
2. The resolution bandwidth of test receiver/spectrum analyzer is 1 MHz and the video bandwidth is 3 MHz for Peak detection (PK) at frequency above 1 GHz.
3. The resolution bandwidth of test receiver/spectrum analyzer is 1 MHz and the video bandwidth is $\geq 1/T$ (Duty cycle $< 98\%$) or 10 Hz (Duty cycle $\geq 98\%$) for Average detection (AV) at frequency above 1 GHz.
4. All modes of operation were investigated and the worst-case emissions are reported.
5. The Radiated Emissions testing was performed in the X, Y and Z axis orientation. The worst-case Axis orientation is recorded in this test report.

Prüfbericht - Nr.: CN21ZGIE (P15C-2.4G) 001
Test Report No.

Seite 33 von 33
Page 33 of 33

Test Results

Factor (dB/m) = Antenna Factor (dB/m) + Cable Loss (dB)
Level (dBuV/m) = Reading (dBuV) + Factor (dB/m)

Please refer to Appendix B.