

ROBOMASTER

Youth Tournament Base 01

User Guide

v1.0 2020.04

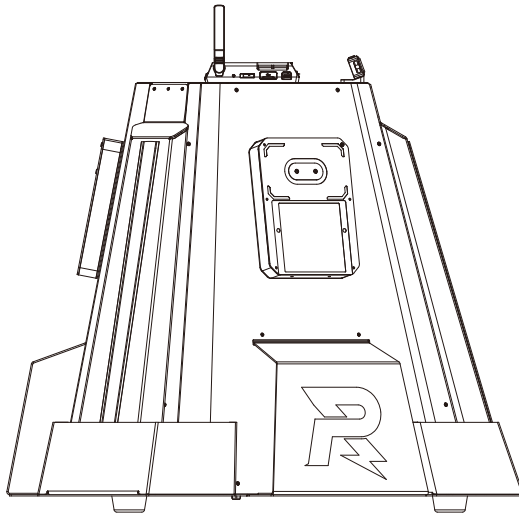

Disclaimer

Thank you for purchasing ROBOMASTER™ Youth Tournament Base 01 (hereinafter referred to as "Base"). Please read this entire document and all safe and lawful practices DJI™ provided carefully before use. Failure to read and follow instructions and warnings may result in serious injury to yourself or others, damage to your DJI product, or damage to other objects in the vicinity. By using this product, you hereby signify that you have read this disclaimer and warning carefully and that you understand and agree to abide by all terms and conditions of this document and all relevant documents of this product. You agree to use this product only for purposes that are proper. You agree that you are solely responsible for your own conduct while using this product, and for any consequences thereof. DJI accepts no liability for damage, injury or any legal responsibility incurred directly or indirectly from the use of this product.

DJI is a trademark of SZ DJI TECHNOLOGY CO., LTD. (abbreviated as "DJI") and its affiliated companies. Names of products, brands, etc., appearing in this document are trademarks or registered trademarks of their respective owner companies. This product and document are copyrighted by DJI with all rights reserved. No part of this product or document shall be reproduced in any form without the prior written consent or authorization of DJI.

This document and all other collateral documents are subject to change at the sole discretion of DJI. For up to date product information, visit www.robomaster.com and click on the product page for this product.

Warning

1. The use of any power adapter not provided officially by DJI may affect the lifespan of or cause permanent damage to the product, or result in current leakage causing personal injury. It is imperative to use an official power adapter provided by DJI.
2. Make sure the Base is correctly connected to the power adapter before use.
3. Avoid hitting or impacting the Base with force. Otherwise, the structure may be damaged and the circuit connections may be loosened.
4. If you detect any flames, smoke, burning smells, or other abnormalities after the Base is powered up, disconnect the power supply immediately.
5. Clean off any gel beads scattered on the Base's structure regularly.

Introduction

The RoboMaster Youth Tournament Base 01 consists of an intelligent controller, camera, light indicator, and Electronic Visual Marker. Its structural surface has been treated with anodizing sandblasting. The Base carries functions such as hit detection, image display, lighting effects, and voice prompts. It can communicate various status information directly through a speaker, light indicator, or Electronic Visual Marker. The Base is suitable for use in areas such as robotic competition, interactive gaming, scientific research, and education.

In the Box

Base × 1

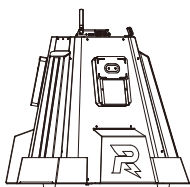

Power Adapter × 1*

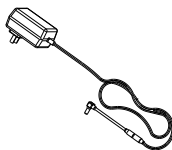

* Varies by region.

Overview

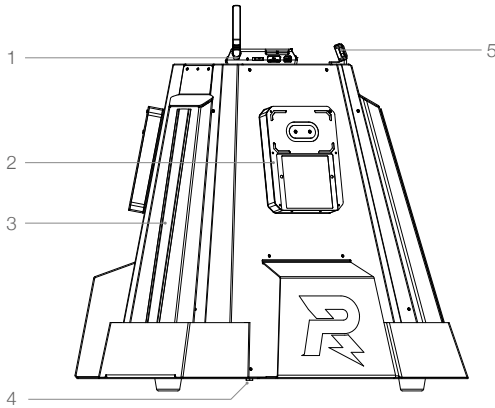

- | | |
|-----------------------------|---------------|
| 1. Intelligent Controller | 4. Power Port |
| 2. Electronic Visual Marker | 5. Camera |
| 3. Light Indicator | |

Usage

Team Identity

After the Base is powered on, the light indicator of the Base and Electronic Visual Marker will display the default light color. The user can determine the Base's default team identity by the light color.

Users may change the default team identity of the Base by connecting to the competition's engine. For specific ways to do so, please refer to the RoboMaster Champion User Guide. Users may access the document on the RoboMaster official website:

<https://www.robomaster.com/zh-CN/products/components/detail/3214>.

Modules

Intelligent Controller

The intelligent controller can operate at a frequency of 2.4 GHz, 5.1 GHz or 5.8 GHz*. It can be used for tasks such as updating Base firmware, connecting to supporting RoboMaster Champions and real-time transmission of data, and is stable with low latency.

* 5.1 GHz only applies to indoor uses. Usage at 5.1GHz must comply with local regulations. Some regions do not allow outdoor uses at such a frequency.

CMIIT ID:2019AP12753

Electronic Visual Marker

The Electronic Visual Marker consists of an armor and LED dot-matrix displays.

A Hit Detector is installed inside each armor, which can detect attacks by any gel bead on the Base.

Each LED dot-matrix display is a 7×7 dot matrix, formed by 49 LEDs. The default background color of the dot-matrix displays is either red or blue, which indicates the team identity of the Base. The default display characters are 1, 2, and 3, shown on three dot-matrix displays, respectively.

Light Indicator

The light indicator indicates the team identity of the Base, the current remaining HP, and the connection status between the intelligent controller and the light indicator control panel. If the intelligent controller and light indicator control panel are disconnected, the light indicator will flash yellow.

Power Port

The power port is used to connect the power adapter to supply power to the Base.

Camera

The camera uses a 1/4-inch sensor which is capable of recognizing objects with specific characteristics and scanning the QR code of the competition client to connect to the Base and the RoboMaster Champion.

Specifications

Model: RMYTBA01

Rated Operating Voltage	12 V
-------------------------	------

Rated Working Current	2 A
-----------------------	-----

Weight	6.6 kg
--------	--------

Dimensions (Length × Width × Height)	620×580×500 mm
--------------------------------------	----------------

Operating Temperature Range	-10° to 40°C
-----------------------------	--------------

WiFi: 802.11 b/g/n

Frequency: 2.412-2.472GHz, 5.180~5.240GHz, 5.745~5.825GHz

WWW.ROBOMASTER.COM

R and **ROBOMASTER** are the trademarks of DJI.
Copyright © 2020 DJI All Rights Reserved.

FCC Compliance Notice

Supplier's Declaration of Conformity

Product name: RoboMaster Youth Tournament Base 01

Model Number: RMYTBA01

Responsible Party: DJI Technology, Inc.

Responsible Party Address: 201 S. Victory Blvd., Burbank, CA 91502

Website: www.dji.com

We, DJI Technology, Inc., being the responsible party, declares that the above mentioned model was tested to demonstrate complying with all applicable FCC rules and regulations.

This device complies with Part 15 of the FCC Rules. Operation is subject to the following two conditions: (1) This device may not cause harmful interference, and (2) This device must accept any interference received, including interference that may cause undesired operation.

Any changes or modifications not expressly approved by the party responsible for compliance could void the user's authority to operate the equipment.

This equipment has been tested and found to comply with the limits for a Class B digital device, pursuant to part 15 of the FCC Rules. These limits are designed to provide reasonable protection against harmful interference in a residential installation. This equipment generates, uses and can radiate radio frequency energy and, if not installed and used in accordance with the instructions, may cause harmful interference to radio communications. However, there is no guarantee that interference will not occur in a particular installation. If this equipment does cause harmful interference to radio or television reception, which can be determined by turning the equipment off and on, the user is encouraged to try to correct the interference by one or more of the following measures:

- Reorient or relocate the receiving antenna.
- Increase the separation between the equipment and receiver.
- Connect the equipment into an outlet on a circuit different from that to which the receiver is connected.
- Consult the dealer or an experienced radio/TV technician for help.

This equipment complies with FCC radiation exposure limits set forth for an uncontrolled environment. This equipment should be installed and operated with minimum distance 20cm between the radiator and your body. This transmitter must not be co-located or operating in conjunction with any other antenna or transmitter.

ISED Compliance Notice

CAN ICES-003 (B) / NMB-003(B)

This device contains licence-exempt transmitter(s)/receiver(s) that comply with Innovation, Science and Economic Development Canada's licence-exempt RSS(s). Operation is subject to the following two conditions: (1) This device may not cause interference. (2) This device must accept any interference, including interference that may cause undesired operation of the device.

L'émetteur/récepteur exempt de licence contenu dans le présent appareil est conforme aux CNR d'Innovation, Sciences et Développement économique Canada

deux conditions suivantes : (1) L'appareil ne doit pas produire de brouillage; (2) L'appareil doit accepter tout brouillage radioélectrique subi, même si le brouillage est susceptible d'en compromettre le fonctionnement.

This equipment complies with IC RSS-102 radiation exposure limits set forth for an uncontrolled environment. This equipment should be installed and operated with minimum distance 20 cm between the radiator and your body.

Cet équipement est conforme aux limites d'exposition aux radiations IC CNR-102 établies pour un environnement non contrôlé. Cet équipement doit être installé et utilisé avec une distance minimale de 20 cm entre le radiateur et votre corps.

The device for operation in the band 5150–5250 MHz is only for indoor use to reduce the potential for harmful interference to co-channel mobile satellite systems; where applicable, antenna type(s), antenna models(s), and worst-case tilt angle(s) necessary to remain compliant with the e.i.r.p. elevation mask requirement set forth in section 6.2.2.3 shall be clearly indicated.

le dispositif utilisé dans la bande 5150-5250 MHz est réservé à une utilisation en intérieur afin de réduire le risque de brouillage préjudiciable aux systèmes mobiles par satellite dans le même canal; le cas échéant, le (s) type (s) d'antenne, le (s) modèle (s) d'antenne et l'angle (s) d'inclinaison le plus défavorable nécessaire (s) pour rester conforme (e) au p.e. L'exigence relative au masque d'élévation énoncée à la section 6.2.2.3 doit être clairement indiquée.



KCC Compliance Notice

“해당무선설비는 운용 중 전파혼신 가능성이 있으므로 인명안전과 관련된 서비스는 할 수 없습니다.”

“해당 무선설비는 운용 중 전파혼신 가능성이 있음”

NCC Compliance Notice

取得審驗證明之低功率射頻器材，非經核准，公司、商號或使用者均不得擅自變更頻率、加大功率或變更原設計之特性及功能。低功率射頻器材之使用不得影響飛航安全及干擾合法通信；經發現有干擾現象時，應立即停用，並改善至無干擾時方得繼續使用。前述合法通信，指依電信管理法規定作業之無線電通信。低功率射頻器材須忍受合法通信或工業、科學及醫療用電波輻射性電機設備之干擾。

應避免影響附近雷達系統之操作。

高增益指向性天線只得應用於固定式點對點系統。



EU Compliance Statement: SZ DJI TECHNOLOGY CO., LTD. hereby declares that this device (RMYTBA01) is in compliance with the essential requirements and other relevant provisions of the Directive 2014/53/EU.

A copy of the EU Declaration of Conformity is available online at www.dji.com/euro-compliance

EU contact address: DJI GmbH, Industriestrasse 12, 97618, Niederlauer, Germany

GB Compliance Statement: SZ DJI TECHNOLOGY CO., LTD. hereby declares that this device (RMYTBA01) is in compliance with the essential requirements and other relevant provisions of Radio Equipment Regulations 2017.

A copy of the GB Declaration of Conformity is available online at www.dji.com/euro-compliance

Declaración de cumplimiento UE: SZ DJI TECHNOLOGY CO., LTD. por la presente declara que este dispositivo (RMYTBA01) cumple los requisitos básicos y el resto de provisiones relevantes de la Directiva 2014/53/EU.

Hay disponible online una copia de la Declaración de conformidad UE en www.dji.com/euro-compliance

Dirección de contacto de la UE: DJI GmbH, Industriestrasse 12, 97618, Niederlauer, Germany

EU-verklaring van overeenstemming: SZ DJI TECHNOLOGY CO., LTD. verklaart hierbij dat dit apparaat (RMYTBA01) voldoet aan de essentiële vereisten en andere relevante bepalingen van Richtlijn 2014/53/EU.

De EU-verklaring van overeenstemming is online beschikbaar op www.dji.com/euro-compliance

Contactadres EU: DJI GmbH, Industriestrasse 12, 97618, Niederlauer, Germany

Declaração de conformidade da UE: A SZ DJI TECHNOLOGY CO., LTD. declara, através deste documento, que este dispositivo (RMYTBA01) está em conformidade com os requisitos essenciais e outras disposições relevantes da Diretiva 2014/53/EU.

Existe uma cópia da Declaração de conformidade da UE disponível online em www.dji.com/euro-compliance
Endereço de contacto na UE: DJI GmbH, Industriestrasse
12, 97618, Niederlauer, Germany

Dichiarazione di conformità UE: SZ DJI TECHNOLOGY CO., LTD. dichiara che il presente dispositivo (RMYTBA01) è conforme ai requisiti essenziali e alle altre disposizioni rilevanti della direttiva 2014/53/EU.

Una copia della dichiarazione di conformità UE è disponibile online all'indirizzo Web www.dji.com/euro-compliance

Indirizzo di contatto UE: DJI GmbH, Industriestrasse
12, 97618, Niederlauer, Germany

Déclaration de conformité UE : Par la présente, SZ DJI TECHNOLOGY CO., LTD déclare que cet appareil (RMYTBA01) est conforme aux principales exigences et autres clauses pertinentes de la directive européenne 2014/53/EU.

Une copie de la déclaration de conformité UE est disponible sur le site www.dji.com/euro-compliance

Adresse de contact pour l'UE : DJI GmbH, Industriestrasse
12, 97618, Niederlauer, Germany

EU-Compliance: Hiermit erklärt SZ DJI TECHNOLOGY CO., LTD., dass dieses Gerät (RMYTBA01) den wesentlichen Anforderungen und anderen einschlägigen Bestimmungen der EU-Richtlinie 2014/53/EU entspricht.

Eine Kopie der EU-Konformitätserklärung finden Sie online auf www.dji.com/euro-compliance

Kontaktadresse innerhalb der EU: DJI GmbH, Industriestrasse
12, 97618, Niederlauer, Germany

Декларация за съответствие на ЕС: SZ DJI TECHNOLOGY CO., LTD. декларира, че това устройство (RMYTBA01) отговаря на основните изисквания и другите приложими разпоредби на Директива 2014/53/ЕС.

Копие от Декларацията за съответствие на ЕС ще намерите онлайн на адрес www.dji.com/euro-compliance

Адрес за контакт за ЕС: DJI GmbH, Industriestrasse
12, 97618, Niederlauer, Германия

Prohlášení o shodě pro EU: Společnost SZ DJI TECHNOLOGY CO., LTD. tímto prohlašuje, že tohle zařízení (RMYTBA01) vyhovuje základním požadavkům a dalším příslušným ustanovením směrnice 2014/53/EU.

Kopie prohlášení o shodě pro EU je k dispozici on-line na webu www.dji.com/euro-compliance

Kontaktní adresa v EU: DJI GmbH, Industriestrasse 12, 97618, Niederlauer, Německo

EU-overensstemmelseserklæring: *SZ DJI TECHNOLOGY CO., LTD.* erklærer hermed, at denne enhed (RMYTBA01) er i overensstemmelse med de væsentlige krav og andre relevante bestemmelser i direktiv 2014/53/EU.

Der er en kopi af EU-overensstemmelseserklæringen tilgængelig online på www.dji.com/euro-compliance

EU-kontaktadresse: DJI GmbH, Industriestrasse 12, 97618, Niederlauer, Tyskland

Δήλωση Συμμόρφωσης ΕΕ: Η *SZ DJI TECHNOLOGY CO., LTD.* δια του παρόντος δηλώνει ότι η συσκευή (RMYTBA01) αυτή συμμορφώνεται με τις βασικές απαιτήσεις και άλλες σχετικές διατάξεις της Οδηγίας 2014/53/ΕΕ.

Αντίγραφο της Δήλωσης Συμμόρφωσης ΕΕ διατίθεται ηλεκτρονικά στη διεύθυνση www.dji.com/euro-compliance

Διεύθυνση επικοινωνίας στην ΕΕ: DJI GmbH, Industriestrasse 12, 97618, Niederlauer, Γερμανία

ELi vastavuskinnitus Käesolevaga teatab *SZ DJI TECHNOLOGY CO., LTD.*, et see seade (RMYTBA01) on kooskõlas direktiivi 2014/53/EL oluliste nõuete ja muude asjakohaste sätetega.

ELi vastavusdeklaratsiooni koopia on kättesaadav veebis aadressil www.dji.com/euro-compliance

Kontaktaadress ELis: DJI GmbH, Industriestrasse 12, 97618, Niederlauer, Saksamaa

Pranešimas dėl atitikties ES reikalavimams Bendrovė „*SZ DJI TECHNOLOGY CO., LTD.*“ tvirtina, kad šis prietaisas (RMYTBA01) atitinka pagrindinius 2014/53/ES direktyvos reikalavimus ir kitas susijusias nuostatas.

ES atitikties deklaracijos kopiją galite rasti adresu www.dji.com/euro-compliance

ES kontaktinis adresas: „DJI GmbH“, Industriestrasse 12, 97618, Niederlauer, Germany (Vokietija)

ES atbilstības paziņojums: *SZ DJI TECHNOLOGY CO., LTD.* ar šo apliecina, ka šī ierīce (RMYTBA01) atbilst direktīvas 2014/53/ES pamatprasībām un pārējiem būtiskiem nosacījumiem.

ES atbilstības deklarācijas kopija pieejama tiešsaistē vietnē www.dji.com/euro-compliance

ES kontaktadrese: DJI GmbH, Industriestrasse 12, 97618, Niederlauer, Vācija

EU:n vaatimustenmukaisuusvakuutus: *SZ DJI TECHNOLOGY CO., LTD.* ilmoittaa täten, että tämä laite (RMYTBA01) on direktiivin 2014/53/EU olennaisten vaatimusten ja sen muiden asiaankuuluvien ehtojen mukainen.

Kopio EU:n vaatimustenmukaisuusvakuutuksesta on saatavana verkossa osoitteessa www.dji.com/euro-compliance

Yhteystiedot EU:ssa: DJI GmbH, Industriestrasse 12, 97618, Niederlauer, Germany

RÁITEAS Comhlíonta an AE: Dearbhaíonn *SZ DJI TECHNOLOGY CO., LTD.* leis seo go bhfuil an gléas seo (RMYTBA01) de réir na gceanglas riachtanach agus na bhforálacha ábhartha eile sa Treoir 2014/53/AE.

Tá coip de Dhearbhú Comhréireachta an AE ar fáil ar líne ag www.dji.com/euro-compliance

Seoladh teagmhála san AE: DJI GmbH, Industriestrasse
12, 97618, Niederlauer, Germany

Dikjarazzjoni ta' Konformità tal-UE: *SZ DJI TECHNOLOGY CO., LTD.* hawnhekk tididikjara li dan l-apparat (RMYTBA01) huwa konformi mar-rekwiziti essenzjali u ma' dispozizzjonijiet relevanti oħra tad-Direttiva 2014/53/UE.

Kopja tad-Dikjarazzjoni ta' Konformità tal-UE hija disponibbli onlajn fis-sit www.dji.com/euro-compliance

Indirizz ta' kuntatt tal-UE: DJI GmbH, Industriestrasse 12, 97618, Niederlauer, il-Ġermanja

Declarația UE de conformitate: Prin prezenta, *SZ DJI TECHNOLOGY CO., LTD.* declară faptul că acest dispozitiv (RMYTBA01) este conform cu cerințele esențiale și celelalte prevederi relevante ale Directivei 2014/53/UE.

Un exemplar al Declarației UE de conformitate este disponibil online, la adresa www.dji.com/euro-compliance

Adresa de contact pentru UE: DJI GmbH, Industriestrasse
12, 97618, Niederlauer, Germania

Izjava EU o skladnosti: Družba *SZ DJI TECHNOLOGY CO., LTD.* izjavlja, da ta naprava (RMYTBA01) ustreza osnovnim zahtevam in drugim ustreznim določbam Direktive 2014/53/EU.

Kopija izjave EU o skladnosti je na voljo na spletu na www.dji.com/euro-compliance
Kontaktni naslov EU: DJI GmbH, Industriestrasse 12, 97618, Niederlauer, Nemčija

EU Izjava o skladnosti: Tvrtka *SZ DJI TECHNOLOGY CO., LTD.* izjavljuje da je ovaj uređaj (RMYTBA01) izrađen u skladu s osnovnim zahtjevima i ostalim relevantnim odredbama Direktive 2014/53/EU.

Kopija EU Izjave o skladnosti dostupna je na mrežnoj stranici www.dji.com/euro-compliance

Adresa EU kontakta: DJI GmbH, Industriestrasse 12 97618, Niederlauer, Njemačka

Vyhlasenie o zhode EÚ: *SZ DJI TECHNOLOGY CO., LTD.* týmto vyhlasuje, že toto zariadenie (RMYTBA01) je v zhode so základnými požiadavkami a ďalšími relevantnými ustanoveniami smernice 2014/53/EÚ.

Kópia tohto Vyhlasenia o zhode EÚ je k dispozícii online na www.dji.com/euro-compliance

Kontaktná adresa v EÚ: DJI GmbH, Industriestrasse 12, 97618, Niederlauer, Nemecko

Deklaracja zgodności UE: Firma *SZ DJI TECHNOLOGY CO., LTD.* niniejszym oświadcza, że przedmiotowe urządzenie (RMYTBA01) jest zgodne z zasadniczymi wymogami i innymi stosownymi postanowieniami dyrektywy 2014/53/UE.

Kopię deklaracji zgodności UE można znaleźć w Internecie na stronie www.dji.com/euro-compliance

Adres do kontaktu w UE: DJI GmbH, Industriestrasse 12, 97618, Niederlauer, Niemcy

EU megfeleléségi nyilatkozat: A *SZ DJI TECHNOLOGY CO., LTD.* ezúton megerősíti, hogy ez az eszköz (RMYTBA01) megfelel a 2014/53/EU Irányelv alapvető követelményeinek és más vonatkozó rendelkezéseinek.

Az EU megfeleléségi nyilatkozat másolata elérhető a www.dji.com/euro-compliance oldalon

EU kapcsolati cím: DJI GmbH, Industriestrasse 12, 97618, Niederlauer, Németország

EU-försäkran om efterlevnad: *SZ DJI TECHNOLOGY CO., LTD.* härmed förklarar att denna enhet (RMYTBA01) uppfyller de väsentliga kraven och andra relevanta bestämmelser i direktivet 2014/53/EU.

En kopia av EU-försäkran om efterlevnad finns att tillgå online på adressen www.dji.com/euro-compliance

Kontaktadress EU: DJI GmbH, Industriestrasse 12, 97618, Niederlauer, Tyskland

Yfirlýsing um fylgni við reglur ESB: *SZ DJI TECHNOLOGY CO., LTD.* lýsir hér með yfir að þetta tæki (RMYTBA01) hlíti mikilvægum kröfum og öðrum viðeigandi ákvæðum tilskipunar 2014/53/ESB.

Nálgast má eintak af ESB-samræmisyfirlýsingunni á netinu á www.dji.com/euro-compliance

Heimilisfang ESB-tengiliðar: DJI GmbH, Industriestrasse 12, 97618, Niederlauer, Germany

AB Uygunluk Beyanı: *SZ DJI TECHNOLOGY CO., LTD.* bu belge ile bu cihazın (RMYTBA01) temel gerekliliklere ve 2014/53/EU sayılı Direktifin diğer ilgili hükümlerine uygun olduğunu beyan eder.

AB Uygunluk Beyanının bir kopyasına www.dji.com/euro-compliance adresinden çevrim içi olarak ulaşılabilir

AB için iletişim adresi: DJI GmbH, Industriestrasse 12, 97618, Niederlauer, Almanya

Environmentally friendly disposal



Old electrical appliances must not be disposed of together with the residual waste, but have to be disposed of separately. The disposal at the communal collecting point via private persons is for free. The owner of old appliances is responsible to bring the appliances to these collecting points or to similar collection points. With this little personal effort, you contribute to recycle valuable raw materials and the treatment of toxic substances.

Umweltfreundliche Entsorgung

Dies ist das Symbol für die getrennte Sammlung von Elektro- und Elektronikgeräten. Elektroaltgeräte dürfen nicht zusammen mit dem Restmüll entsorgt werden (einschließlich Batterien, Akkus und Lampen), sondern müssen separat entsorgt werden. Die Entsorgung an der kommunalen Sammelstelle durch Privatpersonen oder an den von Händlern oder Herstellern eingerichteten Sammelstellen ist kostenlos. Der Besitzer von Altgeräten ist dafür verantwortlich, die persönlichen oder vertraulichen Daten auf den zu entsorgenden Altgeräten zu löschen und die Geräte zu diesen oder ähnlichen Sammelstellen zu bringen. Die Händler sind verpflichtet, Elektroaltgeräte für dich kostenlos zurückzunehmen. Durch diesen geringen Aufwand kannst du zur Wiederverwertung von wertvollen Rohmaterialien beitragen und dafür sorgen, dass umweltschädliche und giftige Substanzen ordnungsgemäß unschädlich gemacht werden.

Tratamiento de residuos responsable con el medio ambiente

Los aparatos eléctricos viejos no pueden desecharse junto con los residuos orgánicos, sino que deben ser desechados por separado. Existen puntos limpios donde los ciudadanos pueden dejar estos aparatos gratis. El propietario de los aparatos viejos es responsable de llevarlos a estos puntos limpios o similares puntos de recogida. Con este pequeño esfuerzo estás contribuyendo a reciclar valiosas materias primas y al tratamiento de residuos tóxicos.

Mise au rebut écologique

Les appareils électriques usagés ne doivent pas être éliminés avec les déchets résiduels. Ils doivent être éliminés séparément. La mise au rebut au point de collecte municipale par l'intermédiaire de particuliers est gratuite. Il incombe au propriétaire des appareils usagés de les apporter à ces points de collecte ou à des points de collecte similaires. Avec ce petit effort personnel, vous contribuez au recyclage de matières premières précieuses et au traitement des substances toxiques.

Smaltimento ecologico

I vecchi dispositivi elettrici non devono essere smaltiti insieme ai rifiuti residui, ma devono essere smaltiti separatamente. Lo smaltimento da parte di soggetti privati presso i punti di raccolta pubblici è gratis. È responsabilità del proprietario dei vecchi dispositivi portarli presso tali punti di raccolta o punti di raccolta analoghi. Grazie a questo piccolo impegno personale contribuirete al riciclo di materie prime preziose e al corretto trattamento di sostanze tossiche.

Milieuvriendelijk afvoeren

Oude elektrische apparaten mogen niet worden weggegooid samen met het restafval, maar moeten afzonderlijk worden afgevoerd. Afvoeren via het gemeentelijke inzamelpunt is gratis voor particulieren. De eigenaar van oude toestellen is verantwoordelijk voor het inleveren van de apparaten op deze of

vergelijkbare inzamelpunten. Met deze kleine persoonlijke inspanning lever je een bijdrage aan de recycling van waardevolle grondstoffen en de verwerking van giftige stoffen.

Eliminação ecológica

Os aparelhos elétricos antigos não podem ser eliminados juntamente com os materiais residuais. Têm de ser eliminados separadamente. A eliminação no ponto de recolha público através de entidades particulares é gratuita. É da responsabilidade do proprietário de aparelhos antigos levá-los a estes pontos de recolha ou a pontos de recolha semelhantes. Com este pequeno esforço pessoal, contribui para a reciclagem de matérias-primas úteis e para o tratamento de substâncias tóxicas.

Изхвърляне с оглед опазване на околната среда

Старите електрически уреди не трябва да се изхвърлят заедно с битовите отпадъци, а отделно. Изхвърлянето в общинския пункт за събиране на отпадъци от частни лица е безплатно. Собственикът на старите уреди е отговорен за пренасянето на уредите до тези или до подобни събирателни пунктове. С това малко собствено усилие допринасяте за рециклирането на ценни суровини и за обработката на токсични вещества.

Ekologicky šetrná likvidace

Stará elektrická zařízení nesmějí být likvidována spolu se zbytkovým odpadem, ale musí být likvidována samostatně. Likvidace na komunálních sběrných místech prostřednictvím soukromých osob je bezplatná. Vlastník starých zařízení odpovídá za to, že je donese do těchto sběrných míst nebo na obdobná sběrná místa. Tímto můžete přispět k recyklaci hodnotných surovin a zpracování toxických látek.

Miljøvenlig bortskaffelse

Gamle elektriske apparater må ikke bortskaffes sammen med restaffald, men skal bortskaffes separat. Bortskaffelse på et fælles indsamlingssted er gratis for privatpersoner. Ejere af gamle apparater er ansvarlige for at bringe apparater hen til disse indsamlingssteder eller til lignende indsamlingssteder. Med denne lille personlige indsats bidrager du til genanvendelse af værdifulde råvarer og behandlingen af giftige stoffer.

Απόρριψη φιλική προς το περιβάλλον

Οι παλιές ηλεκτρικές συσκευές δεν πρέπει να απορρίπτονται μαζί με τα υπολειμματικά απόβλητα, αλλά ξεχωριστά. Η απόρριψη στο δημοτικό σημείο συλλογής μέσω ιδιωτών γίνεται χωρίς χρέωση. Ο κάτοχος παλιών συσκευών είναι υπεύθυνος για τη μεταφορά των συσκευών σε αυτά ή παρόμοια σημεία συλλογής. Μέσω της ατομικής σας προσπάθειας, συμβάλλετε στην ανακύκλωση πολύτιμων πρώτων υλών και την επεξεργασία των τοξικών ουσιών.

Keskkonnasäästlik kasutuselt kõrvaldamine

Vanu elektriseadmeid ei tohi ära visata koos olmejäätmetega, vaid tuleb koguda ja kasutuselt kõrvaldada eraldi. Kohaliku omavalitsuse elektroonikaromude kogumispunktis on äraandmine erasikutele tasuta. Vanade seadmete sellistesse või sarnastesse kogumispunktidesse toimetamise eest vastutavad seadmete omanikud. Selle väikese isikliku panusega aitate kaasa väärtusliku toorme ringlussevõtule ja mürgiste ainete töötlemisele.

Utilizavimas nekenkiant aplinkai

Senų elektrinių prietaisų negalima išmesti kartu su buitineis atliekomis; juos būtina utilizuoti atskirai. Tokių prietaisų utilizavimas per komunalinius atliekų surinkimo punktus yra nemokamas. Elektrinių prietaisų savininkai utilizuojamus prietaisus privalo priduoti į atitinkamus arba analogiškus atliekų surinkimo punktus. Tokiu būdu, įdėdami nedaug pastangų, prisidėsite prie vertingų medžiagų perdirdbimo ir aplinkos apsaugojimo nuo toksinių medžiagų.

Videi draudzīga atkritumu likvidēšana

Vecas elektriskās ierīces nedrīkst likvidēt kopā ar pārējiem atkritumiem, bet tās jālikvidē atsevišķi. Privātpersonām atkritumu likvidēšana komunālajā savākšanas punktā ir bez maksas. Veco ierīču īpašnieks ir atbildīgs par ierīču nogādāšanu šajos savākšanas punktos vai līdzīgos savākšanas punktos. Ar šīm nelielām personiskajām pūlēm jūs veicināt vērtīgu izejmateriālu pārstrādi un toksisko vielu apstrādi.

Hävittäminen ympäristöystävällisesti

Vanhoja sähkölaitteita ei saa hävittää kaatopaikkajätteen mukana, vaan ne on hävitettävä erikseen. Kunnalliseen keräyspisteeseen vieminen on yksityishenkilölle ilmaista. Vanhojen laitteiden omistaja vastaa laitteiden toimittamisesta kyseisiin keräyspisteisiin tai vastaaviin. Tällä vähäisellä henkilökohtaisella vaivalla edistät omalta osaltasi arvokkaiden raaka-aineiden kierrätystä ja myrkyllisten aineiden käsittelyä.

Diúscairt neamhdhíobháilach don chomhshaol

Níor cheart seanghléasanna leictreacha a dhiúscairt leis an dramaíl iarmharach, ach caithfear iad a chur de láimh astu féin. Tá an diúscairt ag an ionad bailiúcháin pobail ag daoine príobháideacha saor in aisce. Tá freagracht ar úinéir seanghléasanna na gléasanna a thabhairt chuig na hionaid bhailiúcháin sin nó chuig ionaid bhailiúcháin den chineál céanna. Le hiarracht bheag phearsanta mar sin, cuidíonn tú le hamhábhair luachmhara a athchúrsáil agus le substaintí tocsaineacha a chóireáil

Rimi li jirrispetta l-ambjent

L-apparat elettriku qadim ma għandux jintrema flimkien ma' skart residwu, iżda għandu jintrema b'mod separat. Ir-rimi fil-post tal-ġbir komunali minn persuni privati huwa b'xejn. Is-sit ta' apparat qadim huwa responsabbli biex iġib l-apparat f'dawn il-postijiet tal-ġbir jew f'postijiet tal-ġbir simili. B'dan l-isforz personali zgħir,

inti tikkontribwixxi għar-riċiklaġġ ta' materja prima prezzjuża u għat-trattament ta' sustanzi tossiċi.

Eliminarea ecologică

Aparatele electrice vechi nu trebuie aruncate odată cu deșeurile reziduale, ci trebuie eliminate separat. Eliminarea în cadrul punctului de colectare local de către persoane fizice este gratuită. Proprietarii de aparate vechi sunt responsabili pentru transportul acestora la respectivele puncte de colectare sau la alte puncte de colectare similare. Prin acest efort personal nesemnificativ, puteți contribui la reciclarea materiilor prime valoroase și la tratarea substanțelor toxice.

Okolju prijazno odlaganje

Starih električnih aparatov ne smete odvreči skupaj z ostanki odpadkov, temveč ločeno. Odlaganje na komunalnem zbirnem mestu je za fizične osebe brezplačno. Lastnik starih naprav je odgovoren, da jih pripelje do teh ali podobnih zbirnih mest. S tako malo osebnega truda prispevate k recikliranju dragocenih surovin in obdelavi strupenih snovi.

Ekološko odlaganje

Stari električni uređaji ne smiju se odlagati zajedno s kućnim otpadom, već ih treba odlagati odvojeno. Odlaganje na komunalnom sabirnom mjestu od strane privatnih osoba je besplatno. Vlasnik starih uređaja dužan je donijeti uređaje do tih sabirnih mjesta ili sličnih sabirnih mjesta. Ovim malim osobnim naporom doprinosite recikliranju vrijednih sirovina i pravilnoj obradi otrovnih tvari.

Ekologická likvidácia

Staré elektrospotrebiče sa nesmú likvidovať spolu so zvyškovým odpadom, ale musia sa zlikvidovať samostatne. Likvidácia v komunálnom zbernom mieste prostredníctvom súkromných osôb je bezplatná. Majiteľ starých spotrebičov je zodpovedný za prinesenie spotrebičov na tieto zberné miesta alebo na podobné zberné miesta. Týmto malým osobným úsilím prispievate k recyklovaniu cenných surovín a spracovaniu toxických látok

Utylizacja przyjazna dla środowiska

Nie można usuwać starych urządzeń elektrycznych wraz z pozostałymi odpadami. Wymagają one oddzielnej utylizacji. Utylizacja przez osoby prywatne w punkcie zbiórki odpadów komunalnych jest darmowa. Właściciel starych urządzeń jest odpowiedzialny za dostarczenie ich do takich lub podobnych punktów zbiórki. Zadając sobie tak niewielki trud, przyczyniasz się do recyklingu cennych surowców i odpowiedniego postępowania z substancjami toksycznymi.

Környezetbarát hulladékkezelés

A régi elektromos készülékeket nem szabad a nem szelektíven gyűjtött hulladékkal együtt kidobni, hanem a hulladékkezelésüket elkülönítve kell végezni A közösségi

gyűjtőpontokon a magánszemélyek ingyenesen leadhatják ezeket. A régi készülékek tulajdonosai felelnek azért, hogy e készülékeket ezekre a gyűjtőpontokra, vagy más gyűjtőpontokra hozzák. Ezzel a kis személyes erőfeszítéssel Ön is hozzájárul az értékes nyersanyagok újrahasznosításához és a mérgező anyagok kezeléséhez.

Miljövämlig hantering av avfall

Gamla elektriska apparater får inte kasseras tillsammans med restavfallet utan måste kasseras separat. Kassering på den lokala insamlingsplatsen för privatpersoner är gratis. Ägaren av gamla apparater ansvarar för att ta apparaterna till dessa insamlingsplatser eller till liknande insamlingsplatser. Med denna lilla personliga insats bidrar du till återvinning av värdefulla råvaror och hantering av giftiga ämnen.

Umhverfisvæn förgun

Ekki má farga gömlum raftækjum með úrgangsleifum, heldur þarf að farga þeim sérstaklega. Förgun á almennum söfnunarstöðum er ókeypis fyrir einstaklinga. Eigandi gamalla tækja ber ábyrgð á að koma með tækin á þessa söfnunarstaði eða á svipaða söfnunarstaði. Með þessu litla persónulega átaki stuðlar þú að endurvinnslu verðmættra hráefna og meðferð eitrurefna.

Çevre dostu bertaraf

Eski elektrikli cihazlar, diğer atıklarla birlikte bertaraf edilmemeli, ayrıca atılmalıdır. Özel kişiler aracılığıyla genel toplama noktasına bertaraf işlemi ücretsiz olarak yapılmaktadır. Eski cihazların sahibi, cihazları bu toplama noktalarına veya benzer toplama noktalarına getirmekten sorumludur. Bu az miktardaki kişisel çabayla, değerli ham maddelerin geri dönüştürülmesine ve toksik maddelerin işleme alınmasına katkıda bulunmuş olursunuz.

This device is restricted to indoor use when operating in the 5150-5250MHz frequency range in all EU/EFTA member states, Turkey and UK.

Im Frequenzbereich 5150-5250 MHz darf dieses Gerät in allen EU/EFTA-Mitgliedsstaaten und der Türkei nur innerhalb von Gebäuden verwendet werden.

El dispositivo está restringido a uso en interiores cuando se opera en el rango de frecuencia de 5150-5250 MHz en todos los estados miembros de la UE/EFTA y Turquía.

Cet appareil est réservé à un usage en intérieur dans une plage de fréquence de 5 150 à 5 250 MHz dans tous les pays membres de l'Union Européenne et de l'Association européenne de libre-échange, ainsi qu'en Turquie.

Il dispositivo è limitato all'uso indoor quando si utilizza l'intervallo di frequenze 5150-5250 MHz in tutti gli stati membri dell'UE e AELS e in Turchia.

Това устройство се ограничава до употреба на закрито, когато работи в честотния диапазон 5150-5250MHz във всички държави-членки на ЕС/ЕАСТ и Турция.

Používání tohoto zařízení v interiéru je omezeno na kmitočtový rozsah 5150–5250 MHz ve všech členských státech EU/EFTA a Turecku.

Denne enhed er begrænset til indendørs brug, når den betjenes i frekvensområdet 5150-5250 MHz i alle EU-/EFTA-medlemslande og Tyrkiet.

Αυτή η συσκευή προορίζεται αποκλειστικά για χρήση σε εσωτερικούς χώρους κατά τη λειτουργία στο εύρος συχνοτήτων 5150-5250MHz σε όλα τα κράτη μέλη της ΕΕ/ΕΖΕΣ και την Τουρκία.

Kui kasutada sagedusvahemikku 5150–5250 MHz, tohib EL-i/EFTA riikides ja Türgis kasutada seadet ainult siseruumides.

Tämä laite on rajoitettu sisäkäyttöön, kun sitä käytetään 5 150–5 250 MHz:n taajuusalueella kaikissa EU/EFTA-jäsenmaissa ja Turkissa.

Níl cead an gléas seo a úsáid ach amháin taobh istigh agus é ag feidhmiú lastigh den raon minicíochta 5150-5250MHz i ngach ballstát den AE/CSTE agus sa Tuirc.

Uporaba ovog uređaj ograničena je na zatvoreni prostor kada radi u frekvencijskom rasponu od 5150 - 5250 MHz u svim državama članicama EU-a/EFTA-a i Turskoj.

Az 5150-5250 MHz-es frekvenciatartományban az eszköz kizárólag beltéren használható az EU/EFTA tagállamokban és Törökországban.

Þetta tæki er takmarkað við notkun innandyra í öllum aðildarríkjum ESB/EFTA og Tyrklandi, þegar það er notað á tíðnisviðinu 5150-5250MHz.

Visose ES/EFTA valstybėse narėse ir Turkijoje šis prietaisas gali būti naudojamas tik patalpose, kai veikia 5150–5250 MHz dažnių diapazone.

Šo ierīci visās ES/EBTA dalībvalstīs un Turcijā drīkst lietot tikai iekštelpās, darbinot to 5150–5250 MHz frekvenču diapazonā.

Dan l-apparat huwa ristrett għall-użu fuq għewwa waqt li jkun qed jopera fil-medda ta' frekwenza 5150-5250 MHz fl-Istati Membri kollha tal-UE/EFTA u fit-Turkija.

Dit apparaat is beperkt tot gebruik binnenshuis bij gebruik binnen het frequentiebereik van 5150-5250MHz in alle EU/EVA-lidstaten en Turkije.

Urządzenie to służy do użytku tylko w pomieszczeniach, gdy działa w zakresie częstotliwości 5150 - 5250 MHz, we wszystkich państwach członkowskich UE/EFTA i w Turcji.

Este dispositivo está limitado à utilização em espaços interiores quando opera na gama de frequências de 5150-5250 MHz em todos os Estados-Membros da UE/EFTA e na Turquia.

Acest dispozitiv este limitat la utilizarea în interior atunci când funcționează în intervalul de frecvență 5150-5250MHz în toate statele membre UE/EFTA și Turcia.

Pri prevádzke vo frekvenčnom rozsahu 5 150 – 5 250 MHz je toto zariadenie vo všetkých členských štátoch EÚ/EFTA a Turecku obmedzené na používanie v interiéri.

Ta pripomoček je v vseh državah članicah EU/EFTA in Turčiji pri delovanju v frekvenčnem območju 5150–5250 MHz omejen na uporabo v zaprtih prostorih.

Denna enhet är begränsad till inomhusanvändning vid drift i frekvensområdet 5150–5250 MHz i alla EU/EFTA-medlemsstater och Turkiet.

Tüm AB/EFTA üye ülkelerinde ve Türkiye'de bu cihazın kullanımı, 5150-5250MHz frekans aralığında yalnızca iç mekanlarda kullanılmak üzere sınırlandırılmıştır.

Operating authorizations must exist to operate the product in the following member states of the European Union, refer to the table below.

					
BE	BG	CZ	DK	DE	EE
IE	EL	ES	FR	HR	IT
CY	LV	LT	LU	HU	MT
NL	AT	PL	PT	RO	SI
SK	FI	SE	UK(NI)	TR	NO
CH	IS	LI			



Japan Compliance Statement :

5150-5250MHz : In case of AP, "only indoor use"

