

AGRAS T16

Quick Start Guide

v1.0

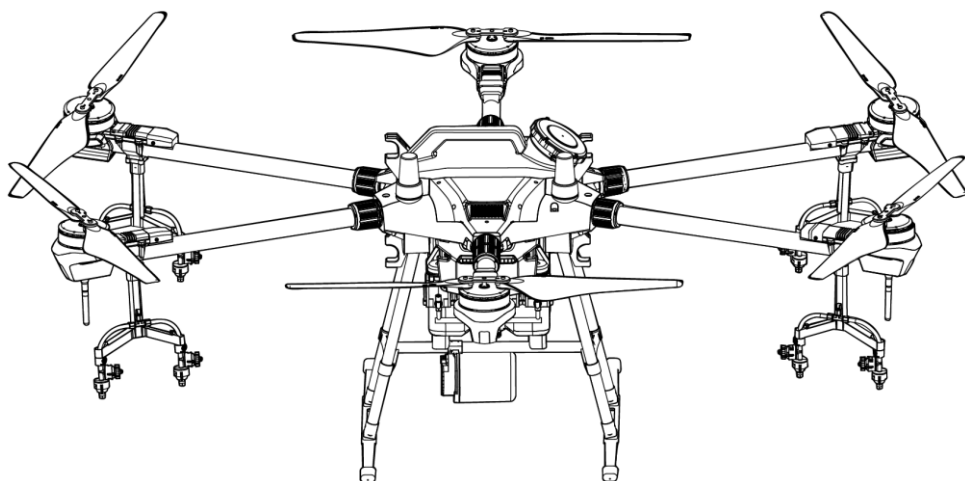

Aircraft

The T16 features a brand-new design including a foldable frame and quick-release spray tank and flight battery, making replacement, installation, and storage easy.

The stable and reliable modular aerial-electronics system is integrated with the dedicated industrial flight controller, OCUSYNC™ 2.0 HD transmission system, and RTK module. It has dual IMUs and barometers and adopts a propulsion control system redundancy design including both digital and analog signals to ensure flight safety. The GNSS+RTK dual-redundancy system supports GPS+GLONASS+BeiDou+Galileo and centimeter-level positioning* when used with the built-in onboard D-RTK™ antennas. The T16 also supports dual-antenna technology that provides strong resistance against magnetic interference.

The upgraded spraying system features an improvement in payload, spray rate, and spray width. It also has a new-generation electromagnetic flow meter, providing high precision and stability. The all-new digital beam forming (DBF) imaging radar features obstacle sensing and terrain following capabilities during both day and night, without being affected by light or dust. It can also plan a flight path to actively circumvent obstacles. The aircraft is equipped with a wide-angle FPV camera enabling observation of the landscape from the front of the aircraft.

The quality of the aircraft's industrial design and materials make it dustproof, waterproof, and corrosion-resistant. The aircraft has a protection rating of IP54 (IEC standard 60529), while the protection rating of the aerial-electronics system, spray control system, and propulsion ESC system is up to IP67.

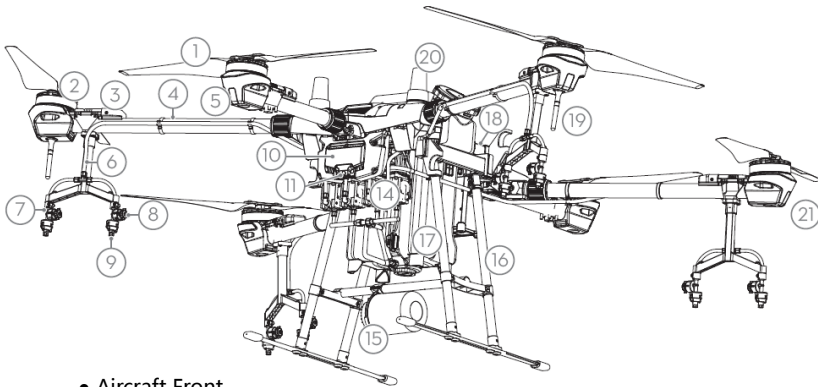

● Aircraft Front

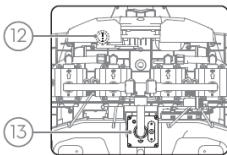

Bottom View

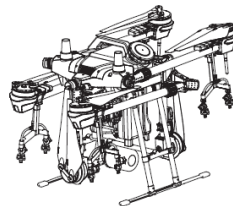

Folded

- | | |
|--|---|
| 1. Propellers | 12. USB-C Port (on the bottom of the aerial-electronics system, with a water-proof cover) |
| 2. Motors | 13. Flow Meter |
| 3. ESCs | 14. Delivery Pumps |
| 4. Frame Arms | 15. DBF Imaging Radar |
| 5. Aircraft Front LEDs (on the three front arms) | 16. Landing Gear |
| 6. Hoses | 17. Spray Tank |
| 7. Sprinklers | 18. Battery Compartment |
| 8. Manual Relief Valve | 19. OcuSync Antennas |
| 9. Nozzles | 20. Onboard D-RTK Antennas |
| 10. Aerial-Electronics System | 21. Aircraft Status Indicators (on the three rear arms) |
| 11. FPV Camera | |

* This should be used with a DJI D-RTK 2 High Precision GNSS Mobile Station (sold separately) or a DJI-approved Network RTK service.

Remote Controller

The remote controller uses the DJI OcuSync dual-band transmission system, has a maximum control distance of up to 3.11 mi (5 km), * and is equipped with a bright, dedicated screen with the new DJI MG app built in. Operation planning can be performed using the remote controller, an RTK hand-held mapping device, or by flying the aircraft to waypoints results in an upgraded spraying system, making flight operation more flexible and efficient. The Multi-Aircraft Control mode of the remote controller can be used to coordinate the operation of up to five aircraft at the same time, enabling pilots to work efficiently. Replaceable batteries make it easy to use the remote controller every day, and removable antennas make maintenance easier.

1. Power Button
2. RTH Button
3. Control Sticks
4. Speaker
5. Lanyard Attachment
6. Status LED
7. Battery Level LEDs
8. USB-C Port
9. 3.5 mm Audio Jack
10. microSD Card Slot
11. Display Device
12. Sleep/Wake Button
13. Antennas

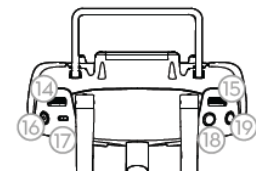
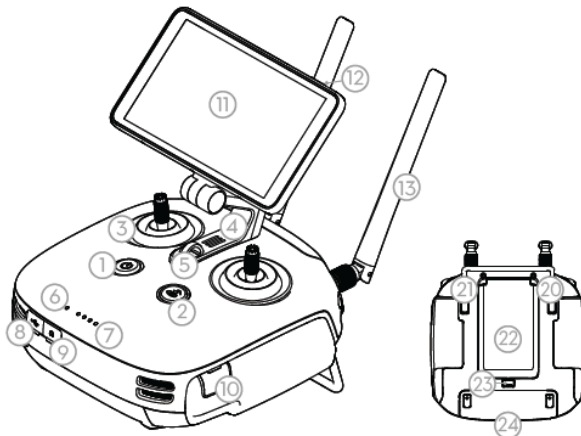

14. Spray Rate Dial
15. Aircraft Control Switch Dial
16. Spray Button
17. Pause Switch
18. Button A (customizable)
19. Button B (customizable)

20. Button C1 (customizable)
21. Button C2 (customizable)
22. Battery Compartment Cover
23. Battery Compartment Cover Lock
24. Dongle Compartment Cover

The figure below shows the function that each control stick movement performs, using Mode 2 as an example. In Mode 2, the left stick controls the aircraft's altitude and heading while the right stick controls its forward, backward, left, and right movements.

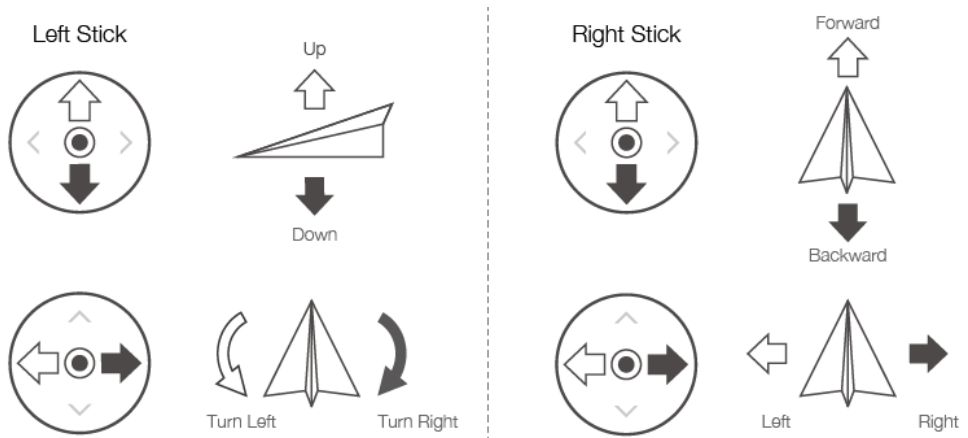

* The remote controller is able to reach its maximum transmission distance (FCC: 3.11 mi (5 km); CE/KCC/MIC/SRRC: 1.86 mi (3 km)) in an open area with no electromagnetic interference, and at an altitude of approximately 8.2 feet (2.5 m).

Fly Safe

It is important to understand some basic flight guidelines, both for your protection and for the safety of those around you.

1. Flying in Open Areas: Pay attention to utility poles, power lines, and other obstacles. DO NOT fly near or above water, people, or animals.
2. Maintain Control at All Times: Always keep your hands on the remote controller and maintain control of your aircraft when it is in flight, even when using intelligent functions such as the Route and A-B Route operation modes and Smart Return to Home.
3. Maintain Line of Sight: Maintain visual line of sight with your aircraft at all times and avoid flying behind buildings or other obstacles that may block your view.
4. Monitor Your Altitude: For the safety of manned aircraft and other air traffic, always fly at altitudes lower than 98 feet (30 meters) and in accordance with all local laws and regulations.



Visit <https://www.dji.com/flysafe> for more information on critical safety features such as GEO Zones.

Flying Considerations

1. DO NOT use the aircraft to spray in winds exceeding 11 mph (18 kph).

2. DO NOT use the aircraft in adverse weather conditions such as winds exceeding 17 mph (28 kph), heavy rain (precipitation rate exceeding 25 mm or 0.98 inches in 12 hours), snow, or fog.
3. The recommended operating altitude is 6,560 feet (2 km) above sea level. DO NOT fly over 9,842 feet (3 km) above sea level.
4. The payload of the spray tank should reduce by 2 kg once the operating altitude increases 3,280 feet (1 km) above sea level.
5. Make sure that there is a strong GNSS signal when operating.

Return to Home (RTH)

The aircraft will automatically return to the Home Point in the following situations:

Smart RTH: You press the RTH button.

Failsafe RTH: The remote controller signal is lost. *

During RTH, if there is an obstacle within 20 m of the aircraft, the aircraft decelerates and then stops and hovers. While decelerating, if the aircraft comes within 6 m of the obstacle, it flies backward to a distance of around 6 m from the obstacle and hovers. The aircraft then exits the RTH procedure and waits for pilot commands.

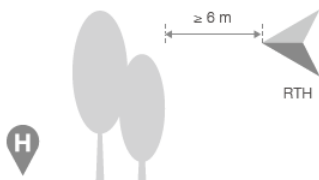

* If Failsafe RTH is disabled (the default setting in the DJI MG app), the aircraft hovers in place when the remote controller signal is lost.

	<ul style="list-style-type: none"> ● Obstacle avoidance is disabled in Attitude mode (which the aircraft enters in situations such as when the GNSS signal is weak) and is not available if the operating environment is not suitable for the radar module. Extra caution is required in such situations.
--	--

Pesticide Usage

1. Avoid the use of powder pesticides as much as possible as they may reduce the service life of the spraying system.
2. Pesticides are poisonous and pose serious risks to safety. Only use them in strict accordance with their specifications.
3. Use clean water to mix the pesticide to avoid blocking the strainer. Clear any blockage before using the equipment.
4. Effective use of pesticides relies on pesticide density, spray rate, spray distance, aircraft speed, wind speed, and wind direction. Consider all factors when using pesticides.
5. Never compromise the safety of people, animals, or the environment during operation.



It is important to understand basic flight guidelines for the safety of both you and those around you.

DO NOT forget to read the Disclaimer and Safety Guidelines.

Using the T16

1. Preparing the Intelligent Flight Battery

Only use DJI-approved flight batteries (model: AB2-17500mAh-51.8V). Check the battery level before flying, and charge it according to the corresponding document.

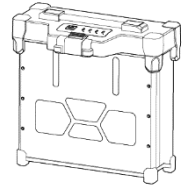

2. Preparing the Aircraft

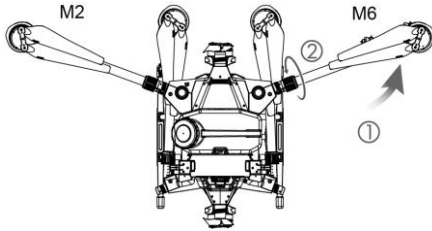

Unfold the M2 and M6 arms, and tighten the two arm sleeves.

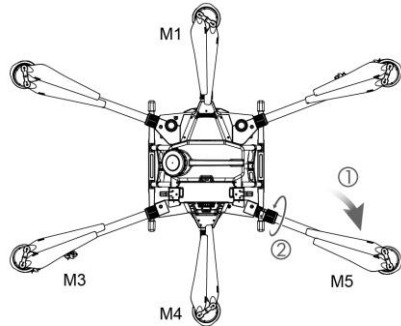

Unfold the M3 and M5 arms, then M1 and M4, and then tighten the four arm sleeves.

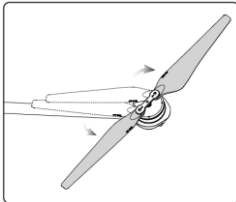

Unfold the propeller blades.

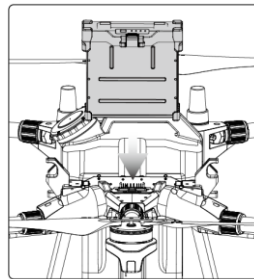

Insert the Intelligent Flight Battery into the aircraft until you hear a click.



- Make sure that the battery is firmly attached to the aircraft. Only insert or remove the battery when it is powered off.
- When folding the arms, make sure to fold the M3 and M5 arms first, and then M2 and M6. Otherwise, the arms may be damaged. Lift and lower the M1 and M4 arms gently to reduce wear and tear.

3. Preparing the Remote Controller

Charging the Battery

Press the battery level button once to check the battery level. Fully charge the batteries before initial use.

Place the battery into the charging hub, connect the AC power adapter to the charging hub, and then connect the AC power adapter to a power outlet (100-240 V, 50/60 Hz).

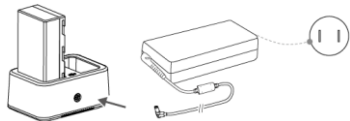

Charging Hub AC Power Adapter Power Outlet

Mounting the Battery

The remote controller uses an easily removable, interchangeable Intelligent Battery for long-term operation.

- ① Slide the battery compartment cover lock on the back of the remote controller down to open the cover.
- ② Insert the Intelligent Battery into the compartment and push it to the top.
- ③ Close the cover.

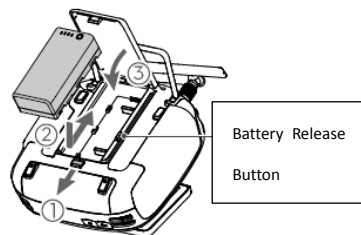

- To remove the Intelligent Battery, open the cover, press and hold the battery release button, then push the battery downward.

Mounting the Dongle and SIM Card



- Only use a DJI-approved dongle.
- The dongle supports various network standards. Use a SIM card that is compatible with the chosen mobile network provider, and select a mobile data plan according to the planned level of usage.
- The dongle and SIM card are used to enable the remote controller to access to specific networks and platforms, such as the DJI AG platform. Be sure to employ them correctly, or else network access will not be available.

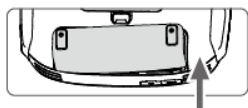

Lift the dongle compartment cover at the gap at its lower right corner, then remove it.

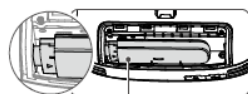

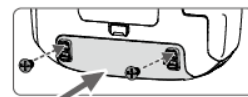

Insert the dongle into the USB port with the SIM card inserted into the dongle and test it. *

Dongle



Reattach the cover. To secure the cover, open the silicone protectors on it, insert and tighten two Phillips screws, then close the protectors.

* Test procedure: Press the remote controller power button once, then press again and hold to turn the remote controller on. In the DJI MG app tap  >  and select **Network Diagnostics**. If the status of all the devices in the network chain are shown in green, the dongle and SIM card are functioning properly.

Checking the Battery Level

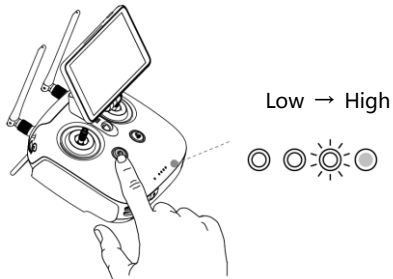

Press once to check the battery level. Press once, then press again and hold for two seconds to turn on/off.

Adjusting the Antennas

Tilt the display device on the remote controller to the desired position, then adjust the antennas, so they are facing outward. The strength of the remote controller signal is affected by the position of the antennas.



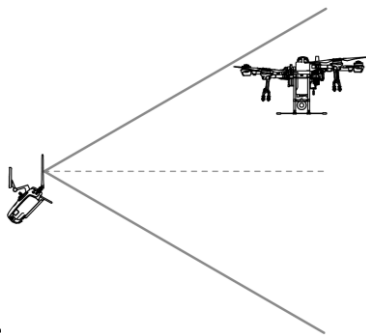

Optimal Transmission Zone

Try to keep the aircraft inside the optimal transmission zone. If the signal is weak, adjust the antennas or fly the aircraft closer.



- Avoid using wireless devices that use the same frequency bands as the remote controller.

4. Getting Ready for Takeoff

- Place the aircraft on open, flat ground with the Aircraft Status Indicators facing toward you.
- Make sure that the propellers are securely mounted, there are no foreign objects in or on the motors and propellers, the propeller blades and arms are unfolded, and the arm sleeves are firmly tightened.
- Make sure that the spray tank and flight battery are firmly in place.
- Pour liquid into the spray tank, and tighten the cover. Make sure that the four fins on the cover are in horizontal or vertical positions respectively.

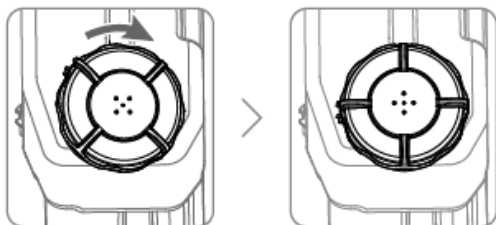

- Power on the remote controller, make sure that the DJI MG app is open, and then power on the aircraft.



When using for the first time, activate it using the DJI MG app. Your DJI account and an Internet connection are required.

Calibrating the Spraying System

Make sure to calibrate the spraying system before your first operation, or else it will adversely affect the spraying performance.

- Preparation before calibration: If there are any bubbles in the hoses, discharge them before calibrating. If there are no

bubbles, proceed with calibration.

- ① Fill the spray tank with about 10 L of water.
- ② Loosen all the manual relief valves and press the Spray button on the remote controller until the bubbles in the hoses have been fully discharged. * Tighten the valves and press the Spray button to stop spraying.

* If the bubbles have still not been fully discharged after an extended period, rotate and remove the valve cover. Reattach the cover once the bubbles have been fully discharged.

B. Spraying System Calibration

- ① Make sure that there is more than 6 L of water in the spray tank. In the DJI MG app, tap Execute Operation to enter Operation View, tap ******* > , then select the correct nozzle model (the standard nozzle is model XR11001VS).
- ② Tap Calibrate. Select the pump requiring calibration (all of the four pumps are selected by default), and tap Calibration.
- ③ Calibration will start automatically. After several minutes, the calibration result will be displayed in the app.
 - If the app displays a successful calibration, users can proceed with the operation.
 - If calibration fails, tap “?” to view the problem and resolve it. Afterwards, select the pump that failed to re-calibrate.

Calibrating the Compass

When the app prompts that compass calibration is required, tap ******* > , slide to the bottom, and select Advanced Settings > Sensors. Tap Calibration in the compass calibration section, then follow the on-screen instructions.

5. Flight

In the DJI MG app, go to Operation View. Make sure that there is a strong GNSS signal, and the system status bar indicates Manual Route (GNSS) or Manual Route (RTK). * Otherwise, the aircraft cannot take off.

It is recommended to create a plan for a field and select an operation to enable the aircraft to take off and perform the operation automatically. Refer to Starting Operations for more information. In other cases, take off and land manually.

* RTK positioning is recommended. In the DJI MG app, go to Operation View > ******* > RTK to enable Aircraft RTK and select a method for receiving RTK signals.

Takeoff

Perform a Combination Stick Command (CSC) and lowly push the throttle stick up to take off.

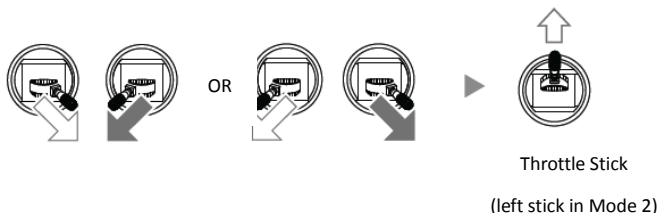

Landing

To land, pull down on the throttle stick to descend until the aircraft touches the ground. There are two methods to stop the motors.

Method 1: When the aircraft has landed, push and hold the throttle stick down. The motors will stop after 3 seconds.



Throttle Stick

Method 2: When the aircraft has landed, push the throttle stick down, then perform the same CSC that was used to start the motors. Release both sticks once the motors have stopped.



Method 1

Method 2

	<ul style="list-style-type: none">• Spinning propellers can be dangerous. Stay away from spinning propellers and motors. DO NOT start the motors in confined spaces or when there are people nearby.• Always keep your hands on the remote controller when the motors are spinning.• DO NOT stop the motors mid-flight unless in an emergency situation where doing so will reduce the risk of damage or injury.• Method 1 is the recommended method for stopping the motors. When using Method 2 to stop the motors, the aircraft may roll over if it is not completely on the ground. Use Method 2 with caution.• After landing, power off the aircraft before turning off the remote controller.
--	---

Starting Operations

The remote controller is equipped with a screen with a built-in Android system that can run the DJI MG app. The Intelligent Operation Planning system built into the app can be used to measure the operation area, identify obstacles, configure waypoints, set aircraft settings, and produce flight route plans. Once flight routes have been planned, they can be used to command the aircraft to fly routes automatically.

In scenarios with complicated terrain, users can use the Phantom 4 RTK and DJI Terra to plan 3D flight routes, and then import the routes to the DJI MG app for operation. Refer to the user manual for more information.

Planning Field

DJI MG app supports flight route planning by walking to waypoints, obstacles, and calibration points carrying the remote controller or an RTK handheld mapping device, or by flying the aircraft to these points. The following description takes planning by flying the aircraft to these points as an example.



Power on the remote controller, followed by the aircraft

Tap **Plan a Field > Fly the aircraft**

The app will display **Manual Route (GNSS)** or **Manual Route (RTK)**

Tap **Start Measuring**



Fly the aircraft alongside the boundary of the operation area and tap **Add Waypoint** at turning points.

Fly near each obstacle * in turn and tap **Start Obstacle Measurement.**

Fly the aircraft around the obstacle and tap **Add Waypoint** at several points around the obstacle. *

Tap **End Obstacle Measurement. ***



Fly to the location of each calibration point and tap **Add Calibration Point.**

Tap **End Measurement.**

Adjust the flight route: route angle, line spacing, and collision avoidance safety margin.

Save the field plan.

* If any obstacles are in the operation area.

Once you have finished planning, tap  in the upper left corner of the screen to return to the main screen.

	<ul style="list-style-type: none"> Operate the aircraft carefully when flying near obstacles to avoid a collision. Calibration points are used to rectify flight route biases caused by GNSS positioning deviations. Choose one or more fixed reference points for calibration like a metal peg or obvious marker that are easy to identify for bias rectification when using the plan.
--	---

Performing an Operation



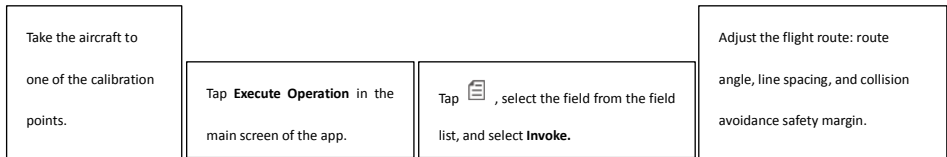



Tap **Rectify Offset**.

Tap **Start**.

Set the operation parameters, then confirm.

Set the auto-takeoff height, move the slider to take off and perform the operation automatically.

	<ul style="list-style-type: none"> ● Only take off in open areas, and set an appropriate auto-takeoff height according to the operating environment. ● An operation can be paused by toggling the Pause switch. The aircraft will hover and record the breakpoint, and then the aircraft can be controlled manually. To continue the operation, select it again from the Executing tag in  list, and the aircraft will return to the breakpoint automatically and resume the operation. Pay attention to aircraft safety when returning to the breakpoint. ● In Route Operation mode, the aircraft is able to circumvent obstacles, which is disabled by default and can be enabled in the app. If the function is enabled, the aircraft will plan a flight path, slow down, and fly across the obstacles after the radar detects the obstacles, then return to the operation path to resume the operation. ● The aircraft will hover at the endpoint of the flight route after the operation is completed. Instead of hovering, the aircraft can also be set to perform other actions in the app.
--	---

More Operation Modes

Refer to the user manual for more information about the A-B Route, Manual, and Manual Plus Operation modes.

More Functions



Operation Resumption

System Data Protection

Empty Tank Warning

Refer to the user manual for more information.

6. Maintenance

Clean all parts of the aircraft daily, immediately after spraying:

A. Completely fill the spray tank with clean water or soapy water and spray the water through the nozzle until the tank is empty. Repeat the step two more times.

B. Detach the spray tank to clean it. Remove the spray tank strainer, nozzle strainers, and nozzles to clean them and clear

any blockage. Afterwards, immerse them in clean water for 12 hours.

C. Use a water-filled spray washer to clean the aircraft body and wipe it with a soft brush or wet cloth before cleaning water stains with a dry cloth. DO NOT splash the aircraft body with an excessive volume of water.

Refer to the Disclaimer and Safety Guidelines for more information on product maintenance.

Specifications

Airframe	
Max Diagonal Wheelbase	1895 mm
Dimensions	2509×2213×732 mm (Arms and propellers unfolded) 1795×1510×732 mm (Arms unfolded and propellers folded) 1100×570×732 mm (Arms and propellers folded)
Propulsion System	
Motor	
Stator Size	100×15 mm
KV	75 rpm/V
Max Thrust	13.5 kg/rotor
Max Power	2400 W/rotor
Weight	616 g
ESC	
Max Working Current (Continuous)	40 A
Working Voltage	51.8 - 58.8 V (14S LiPo)
Foldable Propellers (R3390)	
Diameter × Pitch	33×9 in
Weight (Single propeller)	90 g
Spraying System	
Spray Tank	
Volume	Rated: 15 L, Full: 16 L
Operating Payload	Rated: 15 kg, Full: 16 kg
Nozzle	
Model	XR11001VS (Standard), XR110015VS (Optional, purchase separately)
Quantity	8
Max Spray Rate	XR11001VS: 3.6 L/min, XR110015VS: 4.8 L/min

Spray Width	4-6.5 m (8 nozzles, at a height of 1.5-3 m above crops)
Droplet Size	XR11001VS: 130-250 μm , XR110015VS: 170-265 μm (Subject to operating environment and spray rate)
Flow Meter	
Measurement Range	0.45-5 L/min
Error	< $\pm 2\%$
Measurable Liquid	Conductivity > 50 $\mu\text{S/cm}$ (Liquids such as water or pesticides that contains water)
DBF Imaging Radar	
Model	RD2418R
Operating Frequency	24.05 GHz -24.25 GHz
Power Consumption	15 W
Altitude Detection & Terrain Follow*	Altitude detection range: 1-30 m Stabilization working range: 1.5-15 m Max slope in Mountain mode: 35°
Obstacle Avoidance System*	Obstacle sensing range: 1.5-30 m FOV: Horizontal: $\pm 50^\circ$, Vertical: 0-10° Working conditions: Flying higher than 1.5 m over the obstacle at a speed lower than 7 m/s Safety distance: 2.5 m (Distance between the front of propellers and the obstacle after braking) Obstacle avoidance direction: Forward and backward obstacle avoidance depending on direction of flight.
IP Rating	IP67
*The effective radar range varies depending on the material, position, shape, and other properties of the obstacle.	
FPV Camera	
FOV	Horizontal: 98°, Vertical: 78°
Resolution	1280×960 30 fps
FPV Spotlight	FOV: 110°, Max brightness: 12 lux at 5 m of direct light

Flight Parameters	
Operating Frequency	2.4000 GHz-2.4835 GHz 5.725 GHz-5.850 GHz (Not available in Japan, Korea, and Europe)
Total Weight (Excluding battery)	18.5 kg
Standard Takeoff Weight	39.5 kg
Max Takeoff Weight	40.5 kg (At sea level)
Max Thrust-Weight Ratio	2.05 (Takeoff weight of 39.5 kg)
Hovering Accuracy (With strong GNSS signal)	D-RTK enabled: Horizontal: ± 10 cm, Vertical: ± 10 cm D-RTK disabled: Horizontal: ± 0.6 m, Vertical: ± 0.3 m (Radar module enabled: ± 0.1 m)
RTK/ GNSS Operating Frequency	RTK: GPS L1/L2, GLONASS F1/F2, BeiDou B1/B2, Galileo E1/E5 GNSS: GPS L1, GLONASS F1, Galileo E1
Battery	DJI-approved battery pack (AB2-17500mAh-51.8V)
Max Power Consumption	5600 W
Hovering Power Consumption	4600 W (Takeoff weight of 39.5 kg)
Hovering Time*	18 min (Takeoff weight of 24.5 kg with a 17500 mAh battery) 10 min (Takeoff weight of 39.5 kg with a 17500 mAh battery)
Max Tilt Angle	15°
Max Operating Speed	7 m/s
Max Flying Speed	10 m/s (With strong GNSS signal)
Max Wind Resistance	8 m/s
Max Service Ceiling Above Sea Level	2000 m
Recommended Operating Temperature	0° to 40°C (32° to 104°F)
*Hovering time acquired at sea level with wind speeds lower than 3 m/s.	
Remote Controller	
Model	GL300N
Operating Frequency	2.4000 GHz - 2.4835 GHz

	5.725 GHz- 5.850 GHz (Not available in Japan, Korea, and Europe)
Effective Transmission Distance (Unobstructed, free of interference)	SRR/ MIC/ KCC/ CE: 3 km, NCC/ FCC: 5 km
Display	5.5-inch screen, 1920×1080, 1000 cd/m ² , Android system, 4G RAM + 16G ROM storage
Power Consumption	16 W (Typical value)
Operating Temperature	-10° to 40°C (14° to 104°F)
Storage Temperature	Less than 3 months: -20° to 45°C (68° to 113°F) More than 3 months: 22° to 28°C (70° to 82°F)
Charging Temperature	5° to 40°C (40° to 104°F)
Remote Controller Intelligent Battery	
Model	WB37-4920mAh-7.6V
Battery Type	2S LiPo
Capacity	4920 mAh
Voltage	7.6 V
Energy	37.39 Wh
Charging Temperature	5° to 40°C (40° to 104°F)
Remote Controller Charging Hub	
Model	WCH2
Input Voltage	17.3-26.2 V
Output Voltage and Current	8.7 V, 6 A
Operating Temperature	5° to 40°C (40° to 104°F)
Remote Controller Power Adapter	
Model	A14-057N1A
Input Voltage	100-240 V, 50/60 Hz
Output Voltage	17.4 V
Rated Power	57 W

FCC/ISED Compliance Notice

This device complies with Part 15 of the FCC Rules and ISED licence-exempt RSS standard.. Operation is subject to the following two conditions:

- (1) This device may not cause harmful interference, and
- (2) This device must accept any interference received, including interference that may cause undesired operation.

Any changes or modifications not expressly approved by the party responsible for compliance could void the user's authority to operate the equipment.

Cet appareil est conforme à la section 15 du règlement de la FCC et à la norme RSS sans licence ISED. Son utilisation est soumise aux deux conditions suivantes:

- (1) Cet appareil ne doit pas causer d'interférences nuisibles, et
- (2) Cet appareil doit accepter toutes les interférences reçues, y compris celles susceptibles de provoquer un fonctionnement indésirable.

Tout changement ou modification non expressément approuvé par la partie responsable de la conformité peut annuler le droit de l'utilisateur à utiliser l'équipement.

This equipment has been tested and found to comply with the limits for a Class A digital device, pursuant to part 15 of the FCC Rules. These limits are designed to provide reasonable protection against harmful interference when the equipment is operated in a commercial environment. This equipment generates, uses and can radiate radio frequency energy and, if not installed and used in accordance with the instruction manual, may cause harmful interference to radio communications. Operation of this equipment in a residential area is likely to cause harmful interference in which case the user will be required to correct the interference at his own expense.

RF Exposure Information

Aircraft and HIGH-PRECISION DBF IMAGING RADAR complies with FCC/ISED radiation exposure limits set forth for an uncontrolled environment. In order to avoid the possibility of exceeding the FCC/ISED radio frequency exposure limits, human proximity to the antenna shall not be less than 20cm during normal operation.

For Remote Controller (model:GL300N), SAR tests are conducted using standard operating positions accepted by the FCC/ISED with the device transmitting at its highest certified power level in all tested frequency bands, although the SAR is determined at the highest certified power level, the actual SAR level of the device while operating can be well below the maximum value. Before a new model is available for sale to the public, it must be tested and certified to the FCC/ISED that it does not exceed the exposure limit established by the FCC/ISED. Tests for each product are performed in positions and locations as required by the FCC/ISED. For Handheld operation, this device has been tested and meets the FCC/ISED RF exposure guidelines when used with an accessory designated for this product or when used with an accessory that contains no metal.

For body worn operation, Remote Controller (model:GL300N) has been tested and meets the FCC/ISED RF exposure guidelines when used with an accessory designated for this product or when used with an accessory that contains no metal and that positions the handset a minimum of 0 cm from the body.

Non-compliance with the above restrictions may result in violation of RF exposure guidelines.

Informations sur l'exposition RF

Les aéronefs et HIGH-PRECISION DBF IMAGING RADAR sont conformes aux limites d'exposition aux rayonnements DE FAC/ISEDG fixées pour un environnement incontrôlé. Afin d'éviter la possibilité de dépasser les limites d'exposition à la radiofréquence FCC/ISEDG, la proximité humaine de l'antenne ne doit pas être inférieure à 20 cm pendant le fonctionnement normal.

Pour le contrôleur à distance (modèle GL300N), les tests SAR sont effectués sur des positions de fonctionnement standard acceptées par la FCC/ISEDG, le dispositif émettant à son niveau de puissance certifié le plus élevé dans toutes les bandes de fréquences testées, bien que le SAR soit déterminé au niveau de puissance certifié le plus élevé, le niveau de SAR réel de l'appareil en cours d'utilisation peut être bien inférieur à la valeur maximale. Avant qu'un nouveau modèle ne soit disponible à la vente au public, il doit être testé et certifié conforme par la FCC/ISEDG qu'il n'excède pas la limite d'exposition établie par la FCC/ISEDG. Les tests de chaque produit sont effectués à requis par la FCC/ISEDG. En mode portatif, cet appareil a été testé et respecte les directives d'exposition RF de la FCC/ISEDG lorsqu'il est utilisé avec un accessoire conçu pour ce produit ou avec un accessoire ne contenant pas de métal.

Pour le fonctionnement sur le corps, la télécommande (modèle GL300N) a été testée et répond aux directives d'exposition RF de FCC/ISEDG lorsqu'elle est utilisée avec un accessoire conçu pour ce produit ou avec un accessoire ne contenant pas de métal et positionnant le combiné au minimum de 0 cm du corps.

Le non-respect des restrictions ci-dessus peut entraîner une violation des consignes d'exposition aux RF.

EU Compliance Statement: SZ DJI TECHNOLOGY CO., LTD. hereby declares that this device is in compliance with the essential requirements and other relevant provisions of the RED Directive.

This equipment must be installed and operated in accordance with provide instructions and the antenna used for this transmitter must be installed to provide a separation distance of at least 20cm from all persons and must not be co-located or operation in conjunction with any other antenna or transmitter. End-users and installers must be provide with antenna installation instructions and transmitter operating conditions for satisfying RF exposure compliance.

A copy of the EU Declaration of Conformity is available online at www.dji.com/euro-compliance



Warning: Operation of this equipment in a residential environment could cause radio interference.

KCC Warning Message

해당무선설비는운용중전파혼신가능성이있

해당무선설비는전파혼신가능성이있으므로인명안전과관련된서비스는할수없음

NCC Warning Message

低功率電波輻射性電機管理辦法

第十二條 經型式認證合格之低功率射頻電機，非經許可，公司、商號或使用者均不得擅自變更頻率、加大功率或變更原設計之特性及功能。

第十四條 低功率射頻電機之使用不得影響飛航安全及干擾合法通信；經發現有干擾現象時，應改善至無干擾時方得繼續使用。前項合法通信，指依電信法規定作業之無線電通信。低功率射頻電機須忍受合法通信或工業、科學及醫療用電波輻射性電機設備之干擾。

應避免影響附近雷達系統之操作。

高增益指向性天線只得應用於固定式點對點系統。