

# Mavic Air 2 Quick Start Guide

## Aircraft

The DJI™ MAVIC™ Air 2 features a new folding design and a fully stabilized 3-axis gimbal camera capable of shooting 4K video and 48 MP photos. DJI signature technologies such as Obstacle Sensing and Intelligent Flight Modes like ActiveTrack 3.0, Point of Interest (POI) 3.0, QuickShot, and Advanced Pilot Assistance Systems 2.0, make capturing complex shots effortless and easy. The Mavic Air 2 boasts a maximum flight speed of 42.5 mph (68.4 kph) and a maximum flight time\* of 34 minutes.

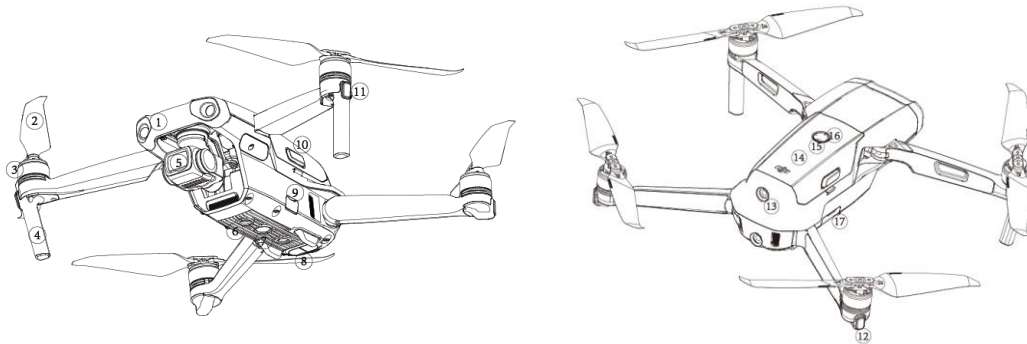

1. Forward Vision System
2. Propellers
3. Motors
4. Landing Gears (Built-in antennas)
5. Gimbal and Camera
6. Downward Vision System
7. Auxiliary Bottom Light
8. Infrared Sensing System
9. USB-C Port
10. Battery Buckles
11. Front LEDs
12. Aircraft Status Indicators
13. Backward Vision System
14. Intelligent Flight Battery
15. Power Button
16. Battery Level LEDs
17. microSD Card Slot

# Remote Controller

Built into the remote controller is DJI's long-range transmission technology OCUSYNC™ 2.0, offering a maximum transmission range of 5 mi (8 km) and displaying video from the aircraft to DJI Fly on your mobile device at up to 1080p.

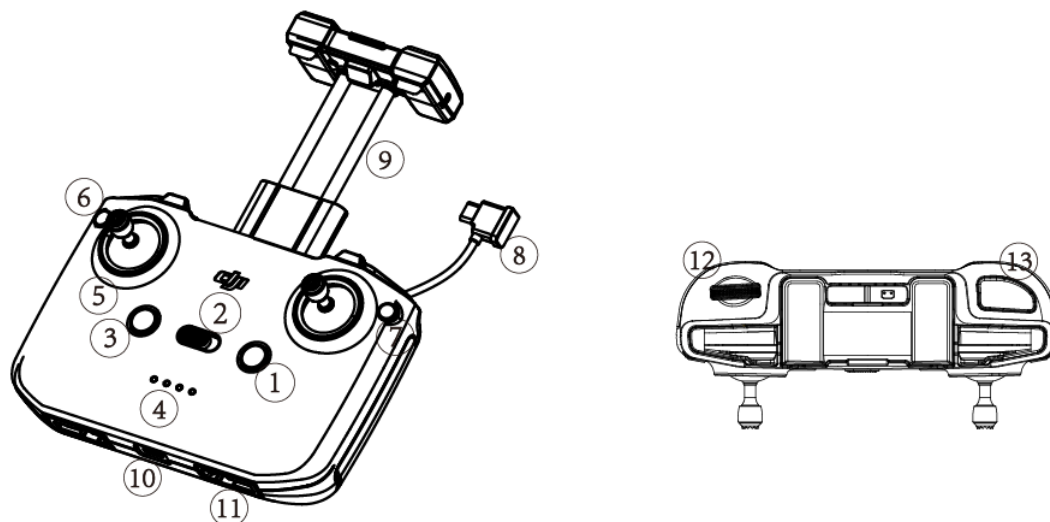

1. Power Button
2. Flight Mode Switch
3. Flight Pause/RTH Button
4. Battery Level LEDs
5. Control Sticks
6. Customizable Button
7. Photo/Video Toggle
8. Remote Controller Cable
9. Mobile Device Holder
10. USB-C Port
11. Control Sticks Storage Slot
12. Gimbal Dial
13. Shoot/Record Button

## Downloading the DJI Fly App

Search for 'DJI Fly' in the App Store or Google Play, or scan the QR code to download the app on your mobile device.



DJI Fly App



## Charging the Batteries

1. Use the provided charger to fully charge the Intelligent Flight Battery before first time use.

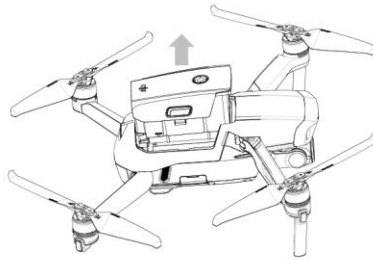

2. Use a USB charger to charge the remote controller via the USB-C port.

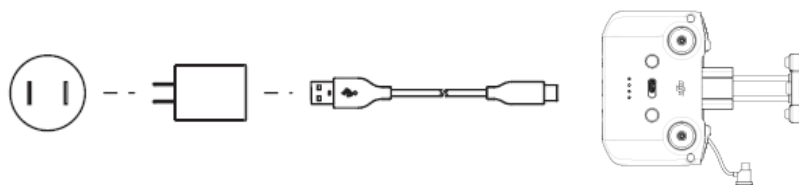

## Preparing the Remote Controller

1. Attach the control sticks.

2. Pull out the mobile device holder, and then unplug the end with mobile phone mark of the RC cable.
3. Place the mobile device onto the mobile device holder, and plug the RC cable into the mobile device.

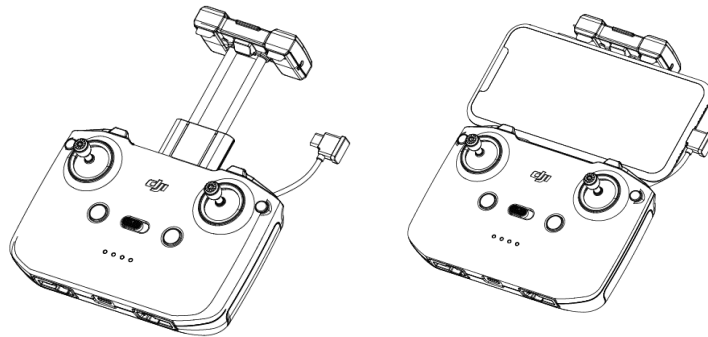

## Preparing the Aircraft

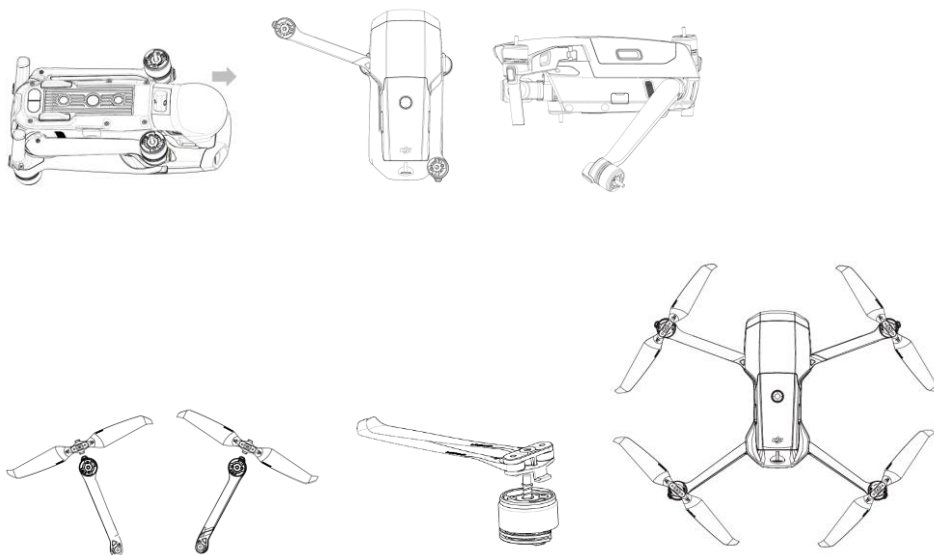

## Preparing for Take off

1. Press the power button of the remote controller once to check the current battery level. Press once, then again and hold to turn on/off the remote controller.
2. Press the power button of the Intelligent Flight Battery once to check the current battery level. Press once, then again and hold to turn on/off the aircraft.
3. Launch DJI Fly.

\* When connect an Android mobile device to the remote controller for the first time, select the default connection settings when there is prompt.

\*\*Use your DJI account to activate the aircraft. Activation requires an internet connection.

## Flight

- Auto Takeoff / Landing



Auto Takeoff



Auto Landing

- Manual Takeoff / Landing

Combination stick command to start/stop the motors



OR



Left stick up (slowly) to take off



Left stick down (slowly) until you touch the ground  
Hold a few seconds to stop the motors

### Remote Controller Operation

#### Left Stick



Up



Down



Turn Left



Turn Right

#### Right Stick



Forward



Backward

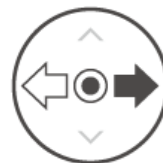

Left

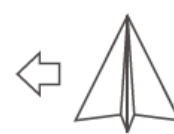

Right



## Specifications

Aircraft (Model: MA2UE1N)	
Operating Temperature	0° to 40°C
Operating Frequency	2.4-2.4835 GHz, 5.725-5.850 GHz*
Transmitter Power	2.4G: ≤20dBm (FCC Conducted power), ≤20 dBm (CE EIRP), ≤20 dBm (SRRC EIRP), ≤20 dBm (MIC conducted power) 5.8G: ≤23.5 dBm (FCC Conducted power), ≤14 dBm (CE EIRP), ≤26 dBm (SRRC EIRP)
Remote Controller (Model: RC231)	
Operating Temperature	0°C-40°C
Transmitter Power	2.4G: ≤24.5 dBm (FCC Conducted power), ≤20 dBm (CE EIRP), ≤20 dBm (SRRC EIRP), ≤20 dBm (MIC conducted power) 5.8G: ≤23.5 dBm (FCC Conducted power), ≤14 dBm (CE EIRP), ≤26 dBm (SRRC EIRP)
Intelligent Flight Battery	
Capacity	3500mAh
Voltage	11.55 V
Battery Type	LiPo 3S
Energy	40.4 Wh
Charging Temperature Range	5°C - 40°C

\* 5.8 GHz is not supported in some regions. Observe the local laws and regulations.

## Compliance Information

FCC ID information:

How to view the aircraft label: press and hold the left and right buttons of the battery to remove the battery. After the battery is removed, the label information can be seen in the battery compartment.

FCC Compliance Notice

This device complies with Part 15 of the FCC Rules. Operation is subject to the following two conditions: (1) This device may not cause harmful interference, and (2) This device must accept any interference received, including interference that may cause undesired operation.

Any changes or modifications not expressly approved by the party responsible for compliance could void the user's authority to operate the equipment.

This equipment has been tested and found to comply with the limits for a Class B digital device, pursuant to part 15 of the FCC Rules. These limits are designed to provide reasonable protection against harmful interference in a residential installation. This equipment generates, uses and can radiate radio frequency energy and, if not installed and used in accordance with the instructions,

may cause harmful interference to radio communications. However, there is no guarantee that interference will not occur in a particular installation. If this equipment does cause harmful interference to radio or television reception, which can be determined by turning the equipment off and on, the user is encouraged to try to correct the interference by one or more of the following measures:

- Reorient or relocate the receiving antenna.
- Increase the separation between the equipment and receiver.
- Connect the equipment into an outlet on a circuit different from that to which the receiver is connected.
- Consult the dealer or an experienced radio/TV technician for help.

The device (AIRCRAFT) complies with FCC radiation exposure limits set forth for an uncontrolled environment. In order to avoid the possibility of exceeding the FCC radio frequency exposure limits, human proximity to the antenna of the drone shall not be less than 20cm during normal operation. This transmitter must not be co-located or operating in conjunction with any other antenna or transmitter.

The device (Remote control) is designed to meet the requirements for exposure to radio waves established by the Federal Communications Commission (USA). These requirements set a SAR limit of 4 W/kg averaged over one gram of tissue. The highest SAR value reported under this standard during product certification for use when properly hold on hand.

### **ISED Compliance Notice**

This device contains licence-exempt transmitter(s)/receiver(s) that comply with Innovation, Science and Economic Development Canada's licence-exempt RSS(s). Operation is subject to the following two conditions: (1) This device may not cause interference. (2) This device must accept any interference, including interference that may cause undesired operation of the device.

L'émetteur/récepteur exempt de licence contenu dans le présent appareil est conforme aux CNR d'Innovation, Sciences et Développement économique Canada applicables aux appareils radio exempts de licence. L'exploitation est autorisée aux deux conditions suivantes : (1) L'appareil ne doit pas produire de brouillage; (2) L'appareil doit accepter tout brouillage radioélectrique subi, même si le brouillage est susceptible d'en compromettre le fonctionnement.

This equipment(AIRCRAFT) complies with RSS - 102 radiation exposure limits set forth for an uncontrolled environment. The drone should be installed and operated with minimum distance 20cm between the radiator and your body. The transmitter must not be co-located or operating in conjunction with any other antenna or transmitter.

Cet équipement est conforme aux limites d'exposition aux radiations CNR - 102 établies pour un environnement non contrôlé. Cet équipement doit être installé et utilisé avec une distance minimale de 20 cm entre le radiateur et votre corps.

These requirements (Remote control) set a SAR limit of 4 W/kg averaged over one gram of tissue. The highest SAR value reported under this standard during product certification for use when properly hold on hand.

Cet équipement est conforme aux limites d'exposition aux rayonnements ISED établies pour un environnement non contrôlé. L'utilisateur final doit suivre les instructions spécifiques pour satisfaire les normes. Cet émetteur ne doit pas être co-implanté ou fonctionner en conjonction avec toute autre antenne ou transmetteur. Le dispositif portatif est conçu pour répondre aux exigences d'exposition aux ondes radio établie par le développement énergétique DURABLE. Ces exigences un SAR limite de 1,6 W/kg en moyenne pour un gramme de tissu. La valeur SAR la plus élevée signalée en vertu de cette norme lors de la certification de produit à utiliser lorsqu'il est correctement porté sur le corps.

## 中国

部件名称	有害物质					
	铅 (Pb)	汞 (Hg)	镉 (Cd)	六价铬 (Cr <sup>+6</sup> )	多溴联苯 (PBB)	多溴二苯醚 (PBDE)
线路板	×	○	○	○	○	○
外壳	×	○	○	○	○	○
金属部件 (铜合金)	×	○	○	○	○	○
内部线材	×	○	○	○	○	○
其他配件	×	○	○	○	○	○

本表格依据SJ/T 11364 的规定编制。

○：表示该有害物质在该部件所有均质材料中的含量均在GB/T 26572 规定的限量要求以下。

×：表示该有害物质至少在该部件的某一均质材料中的含量超出GB/T 26572 规定的限量要求。(产品符合欧盟ROHS指令环保要求)



### KCC Compliance Notice

“해당무선설비는 운용 중 전파혼신 가능성이 있으므로 인명안전과 관련된 서비스는 할 수 없습니다.”

“해당 무선설비는 운용 중 전파혼신 가능성이 있음”

### NCC Compliance Notice



低功率電波輻射性電機管理辦法

第十二條 經型式認證合格之低功率射頻電機，非經許可，公司、商號或使用者均不得擅自變更頻率、加大功率或變更原設計之特性及功能。

第十四條 低功率射頻電機之使用不得影響飛航安全及干擾合法通信；經發現有干擾現象時，應改善至無干擾時方得繼續使用。前項合法通信，指依電信法規定作業之無線電通信。低功率射頻電機須忍受合法通信或工業、科學及醫療用電波輻射性電機設備之干擾。

應避免影響附近雷達系統之操作。

高增益指向性天線只得應用於固定式點對點系統。

設備名稱：待定，型號（型式）：XXXXXX						
單元Unit	限用物質及其化學符號					
	鉛Lead (Pb)	汞Mercury (Hg)	鎘Cadmium (Cd)	六價鉻Hexavalent chromium (Cr <sup>+6</sup> )	多溴聯苯Polybrominated biphenyls (PBB)	多溴二苯醚Polybrominated diphenyl ethers (PBDE)
線路板	-	○	○	○	○	○
外殼	○	○	○	○	○	○
AC 輸入插座	○	○	○	○	○	○
排針	○	○	○	○	○	○
備考 1. “超出 0.1 wt %” 及 “超出 0.01 wt %” 係指限用物質之百分比含量超出百分比含量基準值。						
備考 2. “○” 係指該項限用物質之百分比含量未超出百分比含量基準值。						
備考 3. “-” 係指該項限用物質為排除項目。						



**EU Compliance Statement:** SZ DJI TECHNOLOGY CO., LTD. hereby declares that this device is in compliance with the essential requirements and other relevant provisions of the Directive 2014/53/EU.

A copy of the EU Declaration of Conformity is available online at [www.dji.com/euro-compliance](http://www.dji.com/euro-compliance)

EU contact address: DJI GmbH, Industriestrasse 12, 97618, Niederlauer, Germany

**Declaración de cumplimiento UE:** SZ DJI TECHNOLOGY CO., LTD. por la presente declara que este dispositivo cumple los requisitos básicos y el resto de provisiones relevantes de la Directiva 2014/53/EU.

Hay disponible online una copia de la Declaración de conformidad UE en [www.dji.com/euro-compliance](http://www.dji.com/euro-compliance)

Dirección de contacto de la UE: DJI GmbH, Industriestrasse 12, 97618, Niederlauer, Germany

**EU-verklaring van overeenstemming:** SZ DJI TECHNOLOGY CO., LTD. verklaart hierbij dat dit apparaat voldoet aan de essentiële vereisten en andere relevante bepalingen van Richtlijn 2014/53/EU.

De EU-verklaring van overeenstemming is online beschikbaar op [www.dji.com/euro-compliance](http://www.dji.com/euro-compliance)

Contactadres EU: DJI GmbH, Industriestrasse 12, 97618, Niederlauer, Germany

**Declaração de conformidade da UE:** A SZ DJI TECHNOLOGY CO., LTD. declara, através deste documento, que este dispositivo está em conformidade com os requisitos essenciais e outras disposições relevantes da Diretiva 2014/53/EU.

Existe uma cópia da Declaração de conformidade da UE disponível online em [www.dji.com/euro-compliance](http://www.dji.com/euro-compliance)

Endereço de contacto na UE: DJI GmbH, Industriestrasse 12, 97618, Niederlauer, Germany

**Dichiarazione di conformità UE:** SZ DJI TECHNOLOGY CO., LTD. dichiara che il presente dispositivo è conforme ai requisiti essenziali e alle altre disposizioni rilevanti della direttiva 2014/53/EU.

Una copia della dichiarazione di conformità UE è disponibile online all'indirizzo Web [www.dji.com/euro-compliance](http://www.dji.com/euro-compliance)

Indirizzo di contatto UE: DJI GmbH, Industriestrasse 12, 97618, Niederlauer, Germany

**Déclaration de conformité UE :** Par la présente, SZ DJI TECHNOLOGY CO., LTD déclare que cet appareil est conforme aux principales exigences et autres clauses pertinentes de la directive européenne 2014/53/EU.

Une copie de la déclaration de conformité UE est disponible sur le site [www.dji.com/euro-compliance](http://www.dji.com/euro-compliance)

Adresse de contact pour l'UE : DJI GmbH, Industriestrasse 12, 97618, Niederlauer, Germany

**EU-Compliance:** Hiermit erklärt SZ DJI TECHNOLOGY CO., LTD., dass dieses Gerät den wesentlichen Anforderungen und anderen einschlägigen Bestimmungen der EU-Richtlinie 2014/53/EU entspricht.

Eine Kopie der EU-Konformitätserklärung finden Sie online auf [www.dji.com/euro-compliance](http://www.dji.com/euro-compliance).

Kontaktadresse innerhalb der EU: DJI GmbH, Industriestrasse 12, 97618, Niederlauer, Germany

////电池可更换的产品（比如无人机）增加以下一句话////

CAUTION: RISK OF EXPLOSION IF BATTERY IS REPLACED BY AN INCORRECT TYPE. DISPOSE OF USED BATTERIES ACCORDING TO THE INSTRUCTIONS

#### Environmentally friendly disposal



Old electrical appliances must not be disposed of together with the residual waste, but have to be disposed of separately. The disposal at the communal collecting point via private persons is for free. The owner of old appliances is responsible to bring the appliances to these collecting points or to similar collection points. With this little personal effort, you contribute to recycle valuable raw materials and the treatment of toxic substances.

#### Umweltfreundliche Entsorgung

Elektro-Altgeräte dürfen nicht mit gewöhnlichem Abfall entsorgt werden und müssen separat entsorgt werden. Die Entsorgung an kommunalen Sammelstellen ist für Privatpersonen kostenlos. Die Eigentümer der Altgeräte sind für den Transport zu den Sammelstellen verantwortlich. Durch diesen geringen Aufwand können Sie zur Wiederverwertung von wertvollen Rohmaterialien beitragen und dafür sorgen, dass umweltschädliche und giftige Substanzen ordnungsgemäß unschädlich gemacht werden.

#### Tratamiento de residuos responsable con el medio ambiente

Los aparatos eléctricos viejos no pueden desecharse junto con los residuos orgánicos, sino que deben ser desechados por separado. Existen puntos limpios donde los ciudadanos pueden dejar estos aparatos gratis. El propietario de los aparatos viejos es responsable de llevarlos a estos puntos limpios o similares puntos de recogida. Con este pequeño esfuerzo estás contribuyendo a reciclar valiosas materias primas y al tratamiento de residuos tóxicos.

#### Mise au rebut écologique

Les appareils électriques usagés ne doivent pas être éliminés avec les déchets résiduels. Ils doivent être éliminés séparément. La mise au rebut au point de collecte municipal par l'intermédiaire de particuliers est gratuite. Il incombe au propriétaire des appareils usagés de les apporter à ces points de collecte ou à des points de collecte similaires. Avec ce petit effort personnel, vous contribuez au recyclage de matières premières précieuses et au traitement des substances toxiques.

#### Smaltimento ecologico

I vecchi dispositivi elettrici non devono essere smaltiti insieme ai rifiuti residui, ma devono essere smaltiti separatamente. Lo smaltimento da parte di soggetti privati presso i punti di raccolta pubblici è gratis. È responsabilità del proprietario dei

vecchi dispositivi portarli presso tali punti di raccolta o punti di raccolta analoghi. Grazie a questo piccolo impegno personale contribuirete al riciclo di materie prime preziose e al corretto trattamento di sostanze tossiche.

#### Milieuvriendelijk afvoeren

Oude elektrische apparaten mogen niet worden weggegooid samen met het restafval, maar moeten afzonderlijk worden afgevoerd. Afvoeren via het gemeentelijke inzamelpunt is gratis voor particulieren. De eigenaar van oude toestellen is verantwoordelijk voor het inleveren van de apparaten op deze of vergelijkbare inzamelpunten. Met deze kleine persoonlijke inspanning lever je een bijdrage aan de recycling van waardevolle grondstoffen en de verwerking van giftige stoffen.

#### Eliminação ecológica

Os aparelhos elétricos antigos não podem ser eliminados juntamente com os materiais residuais. Têm de ser eliminados separadamente. A eliminação no ponto de recolha público através de entidades particulares é gratuita. É da responsabilidade do proprietário de aparelhos antigos levá-los a estes pontos de recolha ou a pontos de recolha semelhantes. Com este pequeno esforço pessoal, contribui para a reciclagem de matérias-primas úteis e para o tratamento de substâncias tóxicas.

#### Безопасная для окружающей среды утилизация

Старые электрические приборы нельзя выбрасывать вместе с бытовыми отходами, их утилизация производится отдельно. Частные лица могут сдавать приборы в специальные пункты приема бесплатно. Владельцы старой техники несут ответственность за ее сдачу в специальный пункт приема или аналогичную службу. Чтобы внести свой вклад в переработку ценного сырья и ядовитых веществ, от вас требуется совсем небольшое усилие.

#### Thailand Warning message

เครื่องโทรคมนาคมและอุปกรณ์นี้ มีความสอดคล้องตามข้อกำหนดของ กทท.

#### Mexico Warning message

“La operación de este equipo está sujeta a las siguientes dos condiciones: (1) es posible que este equipo o dispositivo no cause interferencia perjudicial y (2) este equipo o dispositivo debe aceptar cualquier interferencia, incluyendo la que pueda causar su operación no deseada.”

#### Brazil Warning message

Este equipamento opera em caráter secundário, isto é, não tem direito a proteção contra interferência prejudicial, mesmo de estações do mesmo tipo, e não pode causar interferência a sistemas operando em caráter primário



