

# FCC PART 15B

## TEST REPORT

For

### SZ DJI TECHNOLOGY CO., LTD

14th floor, West Wing, Skyworth Semiconductor Design Building NO.18 Gaoxin South 4th Ave,  
Nanshan, Shenzhen, Guangdong, China

**FCC ID: SS3-M1P1607**

<b>Report Type:</b> Original Report	<b>Product Type:</b> Mavic Pro
<b>Test Engineer:</b> Kira Liu	<i>Kira Liu</i>
<b>Report Number:</b> RDG160806002-00C	
<b>Report Date:</b> 2016-08-20	
<b>Reviewed By:</b> Ivan Cao Assistant Manager	<i>Ivan Cao</i>
<b>Test Laboratory:</b> Bay Area Compliance Laboratories Corp. (Dongguan) No.69 Pulongcun, Puxinhu Industrial Zone, Tangxia, Dongguan, Guangdong, China Tel: +86-769-86858888 Fax: +86-769-86858891 <a href="http://www.baclcorp.com.cn">www.baclcorp.com.cn</a>	

**Note:** This test report is prepared for the customer shown above and for the device described herein. It may not be duplicated or used in part without prior written consent from Bay Area Compliance Laboratories Corp. (Dongguan).

**TABLE OF CONTENTS**

**GENERAL INFORMATION.....3**

    PRODUCT DESCRIPTION FOR EQUIPMENT UNDER TEST (EUT).....3

    OBJECTIVE .....3

    RELATED SUBMITTAL(S)/GRANT(S).....3

    TEST FACILITY .....4

**SYSTEM TEST CONFIGURATION.....5**

    JUSTIFICATION .....5

    EUT EXERCISE SOFTWARE .....5

    EQUIPMENT MODIFICATIONS .....5

    TEST SOFTWARE CONFIGURATION.....5

    SUPPORT EQUIPMENT LIST AND DETAILS .....5

    EXTERNAL CABLE.....5

    BLOCK DIAGRAM OF TEST SETUP .....6

**SUMMARY OF TEST RESULTS .....7**

**FCC§15.107 - CONDUCTED EMISSIONS.....8**

    MEASUREMENT UNCERTAINTY .....8

    EUT SETUP .....8

    EMI TEST RECEIVER SETUP.....9

    TEST EQUIPMENT LIST AND DETAILS.....9

    TEST PROCEDURE .....9

    CORRECTED AMPLITUDE & MARGIN CALCULATION .....9

    TEST DATA .....10

**FCC §15.109 - RADIATED EMISSIONS .....21**

    MEASUREMENT UNCERTAINTY .....21

    EUT SETUP .....21

    EMI TEST RECEIVER SETUP.....22

    TEST PROCEDURE .....22

    CORRECTED AMPLITUDE & MARGIN CALCULATION .....23

    TEST EQUIPMENT LIST AND DETAILS.....23

    TEST DATA .....23

## GENERAL INFORMATION

### Product Description for Equipment under Test (EUT)

The *SZ DJI TECHNOLOGY CO., LTD*'s product, model number: *MIP (FCC ID: SS3-M1P1607)* (the "EUT") in this report was a *Mavic Pro*, which was measured approximately: 303.3mm (L) x 249.5mm (W) x 75.2mm(H), rated input voltage: DC11.4V from lithium battery, the battery can remove from the EUT and charged by adapter.

#### Adapter 1 information:

Manufacturer: AcTel Electronic (Dong guan) Co., Ltd./China  
Model: F1C50  
Input: AC 100-240V, 1.4A, 50-60Hz  
Total Output Power: 50W Max;  
Output: DC13.05V, 3.83A(Main); DC5.0V, 2.0A Total(USB)

#### Adapter 2 information:

Manufacturer: Shenzhen Huntkey Electronics Co., Ltd.  
Model: F1C50  
Input: AC 100-240V, 1.4A, 50-60Hz  
Total Output Power: 50W Max;  
Output: DC13.05V, 3.83A(Main); DC5.0V, 2.0A Total(USB)

#### Battery 1 information:

Manufacturer: Sunwoda Electronic Co., LTD.  
Model: FB1-3830 mAh-11.4V  
Max Charge Voltage: 13.05V  
Nominal Voltage: 11.4V  
Rated Capacity: 3830mAh

#### Battery 2 information:

Manufacturer: Dongguan Amperex Technology Limited  
Model: FB1-3830 mAh-11.4V  
Max Charge Voltage: 13.05V  
Nominal Voltage: 11.4V  
Rated Capacity: 3830mAh, 43.6Wh

*\* All measurement and test data in this report was gathered from production sample serial number: 160806002. (Assigned by BACL.Dongguan). The EUT was received on 2016-08-01.*

### Objective

This report is prepared on behalf of *SZ DJI TECHNOLOGY CO., LTD* in accordance with Part 2, Subpart J, Part 15, Subparts A and B of the Federal Communications Commission rules.

The objective of the manufacturer is to determine compliance with FCC Part 15B, Class B.

### Related Submittal(s)/Grant(s)

FCC Part 15E NII submissions with FCC ID: SS3-M1P1607.  
FCC Part 15C DTS submissions with FCC ID: SS3-M1P1607.  
Part of system submissions with FCC ID: SS3-GL200A1606.

### **Test Facility**

The Test site used by Bay Area Compliance Laboratories Corp. (Dongguan) to collect test data is located on the No.69 Pulongcun, Puxinhu Industrial Zone, Tangxia, Dongguan, Guangdong, China

Test site at Bay Area Compliance Laboratories Corp. (Dongguan) has been fully described in reports submitted to the Federal Communication Commission (FCC). The details of these reports have been found to be in compliance with the requirements of Section 2.948 of the FCC Rules on February 02, 2015.

The Federal Communications Commission has the reports on file and is listed under FCC Registration No.: 273710. The test site has been approved by the FCC for public use and is listed in the FCC Public Access Link (PAL) database.

## SYSTEM TEST CONFIGURATION

### Justification

The system was configured for testing in a typical fashion (as normally used by a typical user).

### EUT Exercise Software

The software “winthrax.exe” was used during test.

### Equipment Modifications

No modification was made to the EUT.

### Test Software Configuration

No software was used in testing.

### Support Equipment List and Details

Manufacturer	Description	Model	Serial Number
DELL	Laptop	PP11L	QDS-BRCM1017
HP	Printer	C3941A	JPTVOB2337
DELL	Keyboard	L100	CNORH656658907BL05 DC
SAST	Modem	AEM-2100	0293
Apple	iPhone	A1524	X3CY0TCP17CCCTY
DJI	Remote	GL200A	/

### External Cable

Cable Description	Shielding Type	Ferrite Core	Length (m)	From Port	To
Serial Cable	Yes	No	1.2	Serial Port of Laptop	Modem
Parallel Cable	Yes	No	1.2	ParallelPort of Laptop	Printer
Keyboard Cable	Yes	Yes	1.8	USB Port of Laptop	Keyboard
Adapter 1 DC cable	yes	No	1.98	Adapter	Battery& Remote
Adapter 2 DC cable	yes	No	1.98	Adapter	Battery& Remote
USB Cable	Yes	No	1.0	Adapter	iPhone

### Block Diagram of Test Setup

Downloading Mode:

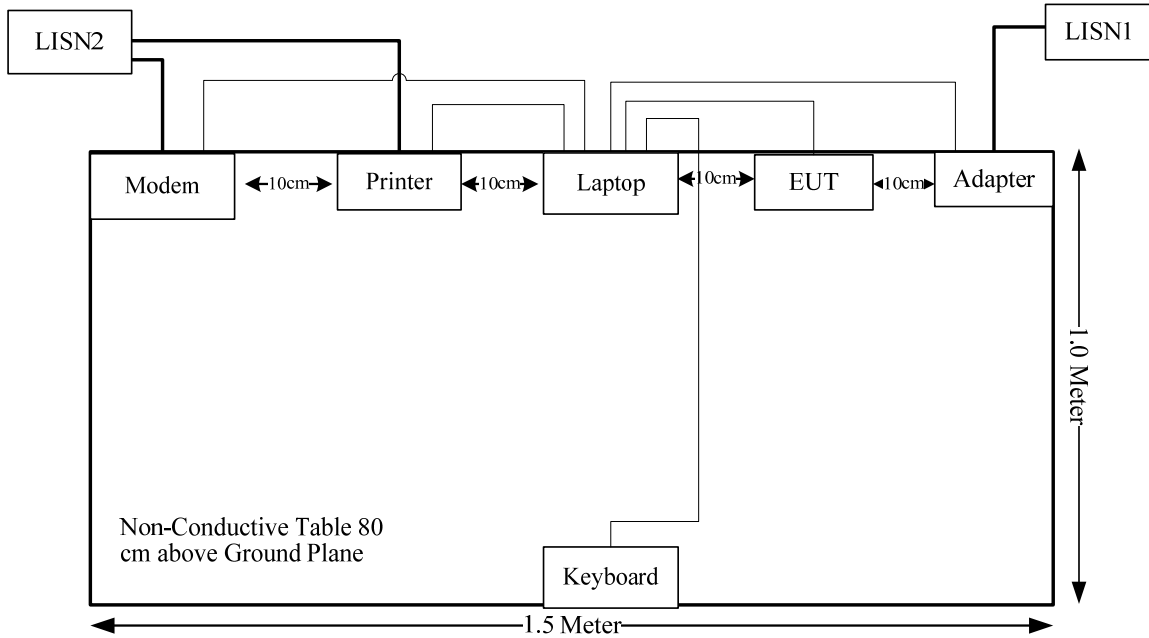

Charging Mode:

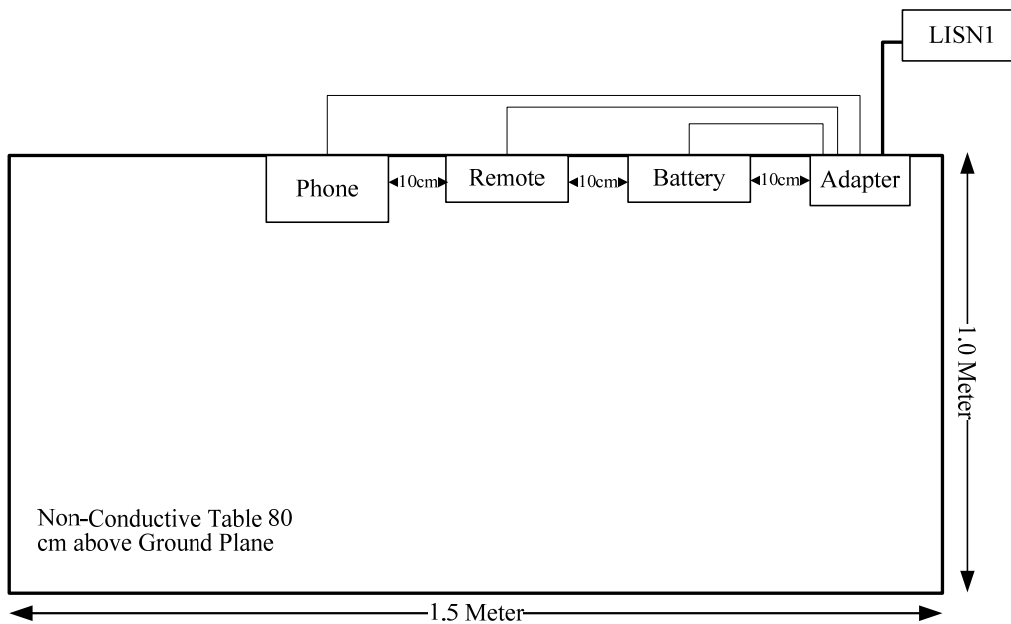

---

## **SUMMARY OF TEST RESULTS**

---

<b>FCC Rules</b>	<b>Description of Test</b>	<b>Results</b>
§15.107	AC Line Conducted Emissions	Compliance
§15.109	Radiated Emissions	Compliance

## FCC§15.107 - CONDUCTED EMISSIONS

### Measurement Uncertainty

All measurements involve certain levels of uncertainties, especially in field of EMC. The factors contributing to uncertainties are Receiver, cable loss, and LISN.

Compliance or non-compliance with a disturbance limit shall be determined in the following manner:

If  $U_{lab}$  is less than or equal to  $U_{cispr}$  of Table 1, then:

- compliance is deemed to occur if no measured disturbance level exceeds the disturbance limit;
- non-compliance is deemed to occur if any measured disturbance level exceeds the disturbance limit.

If  $U_{lab}$  is greater than  $U_{cispr}$  of Table 1, then:

- compliance is deemed to occur if no measured disturbance level, increased by  $(U_{lab} - U_{cispr})$ , exceeds the disturbance limit;
- non-compliance is deemed to occur if any measured disturbance level, increased by  $(U_{lab} - U_{cispr})$ , exceeds the disturbance limit.

Based on CISPR 16-4-2: 2011, measurement uncertainty of conducted disturbance at mains port using AMN at Bay Area Compliance Laboratories Corp. (Dongguan) is 3.12 dB (150 kHz to 30 MHz).

Table 1 – Values of  $U_{cispr}$

Measurement	$U_{cispr}$
Conducted disturbance at mains port using AMN (150 kHz to 30 MHz)	3.4 dB

### EUT Setup

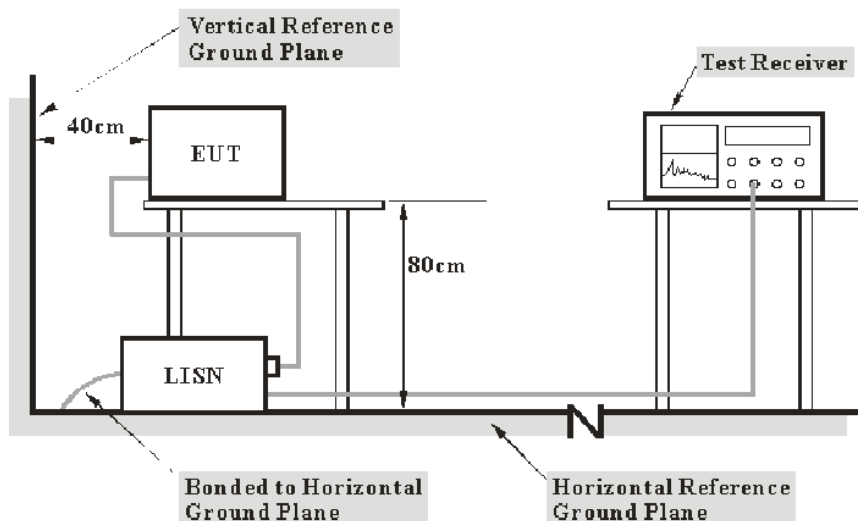

- Note: 1. Support units were connected to second LISN.  
 2. Both of LISNs (AMN) 80 cm from EUT and at the least 80 cm from other units and other metal planes support units.



The setup of EUT is according with per ANSI C63.4-2014 measurement procedure. The specification used was with the FCC Part 15 B Class B limits.

The external I/O cables were draped along the test table and formed a bundle 30 to 40 cm long in the middle.

The adapter was connected to a 120V/60Hz AC power source.

### EMI Test Receiver Setup

The EMI test receiver was set to investigate the spectrum from 150 kHz to 30 MHz.

During the conducted emission test, the EMI test receiver was set with the following configurations:

Frequency Range	IF B/W
150 kHz – 30 MHz	9 kHz

### Test Equipment List and Details

Manufacturer	Description	Model	Serial Number	Calibration Date	Calibration Due Date
R&S	EMI Test Receiver	ESCS 30	830245/006	2015-12-10	2016-12-09
R&S	L.I.S.N	ESH2-Z5	892107/021	2016-07-16	2017-07-15
R&S	Two-line V-network	ENV 216	3560.6550.12	2015-11-26	2016-11-25
R&S	Test Software	EMC32	Version8.53.0	N/A	N/A

\* Statement of Traceability: Bay Area Compliance Laboratories Corp. (Dongguan) attests that all calibrations have been performed, traceable to National Primary Standards and International System of Units (SI).

### Test Procedure

During the conducted emission test, the adapter of laptop was connected to the outlet of the first LISN and the other support equipments were connected to the outlet of the second LISN.

Maximizing procedure was performed on the six (6) highest emissions of the EUT.

All data was recorded in the Quasi-peak and average detection mode.

### Corrected Amplitude & Margin Calculation

The basic equation is as follows:

$$V_C = V_R + A_C + VDF$$

Herein,

$V_C$ : corrected voltage amplitude

$V_R$ : reading voltage amplitude

$A_C$ : attenuation caused by cable loss

VDF: voltage division factor of AMN or ISN

The “**Margin**” column of the following data tables indicates the degree of compliance within the applicable limit. For example, a margin of 7dB means the emission is 7dB below the maximum limit. The equation for margin calculation is as follows:

$$\text{Margin} = \text{Limit} - \text{Corrected Amplitude}$$

## Test Data

### Environmental Conditions

<b>Temperature:</b>	27.2°C
<b>Relative Humidity:</b>	67%
<b>ATM Pressure:</b>	98.9 kPa

*The testing was performed by Kira Liu on 2016-08-18.*

Test Mode: Downloading

AC120V, 60Hz, Line:

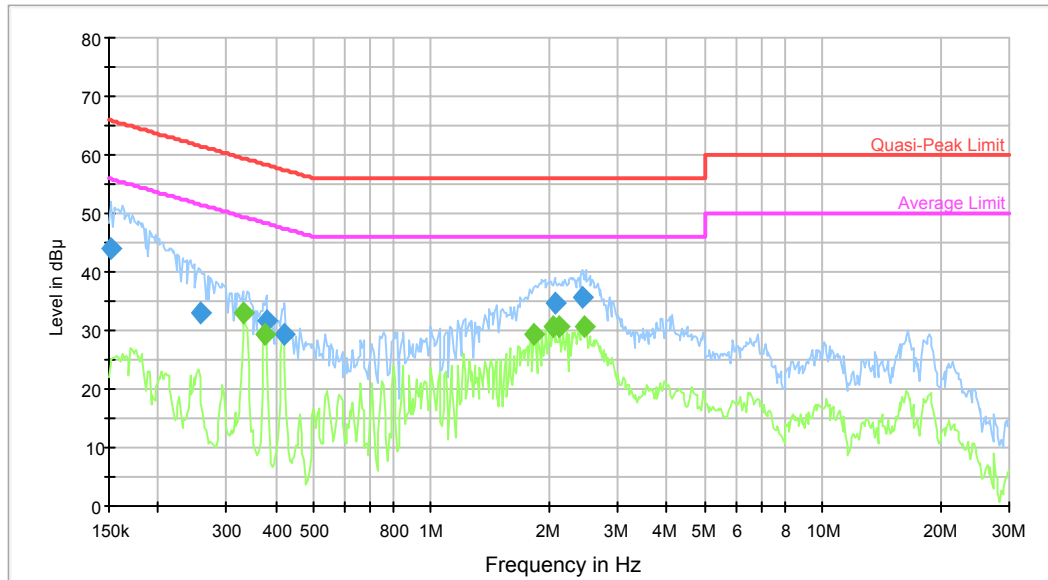

Frequency (MHz)	QuasiPeak (dBµV)	Bandwidth (kHz)	Line	Corr. (dB)	Margin (dB)	Limit (dBµV)	Comment
0.152410	44.1	9.000	L1	10.2	21.8	65.9	Compliance
0.255827	32.9	9.000	L1	10.2	28.7	61.6	Compliance
0.378019	31.7	9.000	L1	10.2	26.6	58.3	Compliance
0.422630	29.5	9.000	L1	10.2	27.9	57.4	Compliance
2.063510	34.7	9.000	L1	10.4	21.3	56.0	Compliance
2.439371	35.5	9.000	L1	10.4	20.5	56.0	Compliance

Frequency (MHz)	Average (dBµV)	Bandwidth (kHz)	Line	Corr. (dB)	Margin (dB)	Limit (dBµV)	Comment
0.332770	33.1	9.000	L1	10.3	16.3	49.4	Compliance
0.375019	29.2	9.000	L1	10.3	19.2	48.4	Compliance
1.831043	29.2	9.000	L1	10.4	16.8	46.0	Compliance
2.047133	30.5	9.000	L1	10.4	15.5	46.0	Compliance
2.130339	30.6	9.000	L1	10.4	15.4	46.0	Compliance
2.458886	30.7	9.000	L1	10.4	15.3	46.0	Compliance

**AC120V, 60Hz, Neutral:**

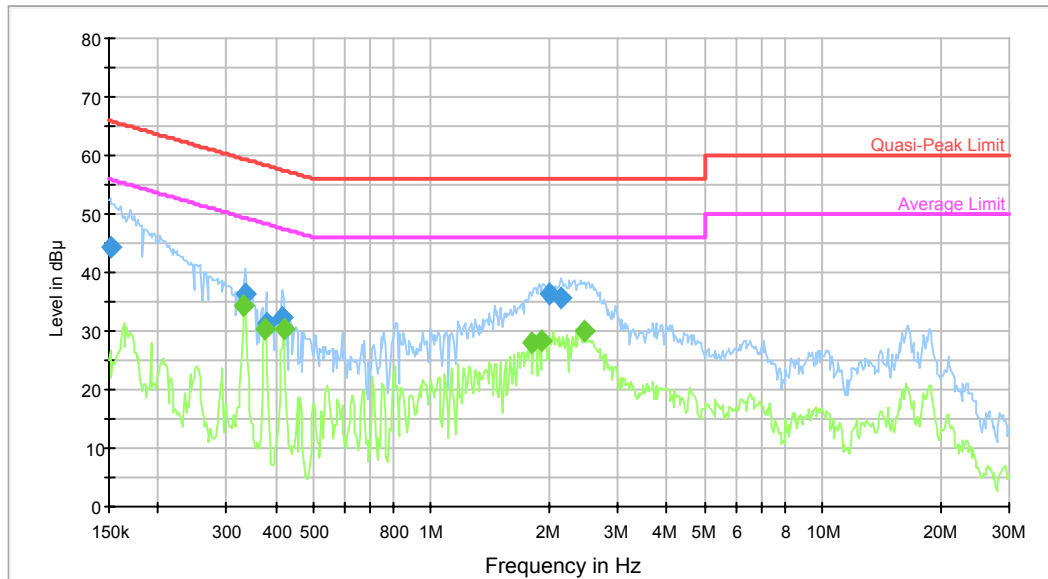

Frequency (MHz)	QuasiPeak (dBµV)	Bandwidth (kHz)	Line	Corr. (dB)	Margin (dB)	Limit (dBµV)	Comment
0.151200	44.4	9.000	N	10.2	21.5	65.9	Compliance
0.335433	36.3	9.000	N	10.3	23.0	59.3	Compliance
0.378019	31.3	9.000	N	10.2	27.0	58.3	Compliance
0.415949	32.2	9.000	N	10.2	25.3	57.5	Compliance
1.998778	36.4	9.000	N	10.4	19.6	56.0	Compliance
2.147382	35.5	9.000	N	10.4	20.5	56.0	Compliance

Frequency (MHz)	Average (dBµV)	Bandwidth (kHz)	Line	Corr. (dB)	Margin (dB)	Limit (dBµV)	Comment
0.332770	34.2	9.000	N	10.3	15.2	49.4	Compliance
0.375019	30.2	9.000	N	10.2	18.2	48.4	Compliance
0.419276	30.4	9.000	N	10.2	17.1	47.5	Compliance
1.802095	28.0	9.000	N	10.4	18.0	46.0	Compliance
1.920710	28.5	9.000	N	10.4	17.5	46.0	Compliance
2.458886	30.1	9.000	N	10.4	15.9	46.0	Compliance

Test Mode: Charging

Adapter 1&Battery 1

AC120V, 60Hz, Line:

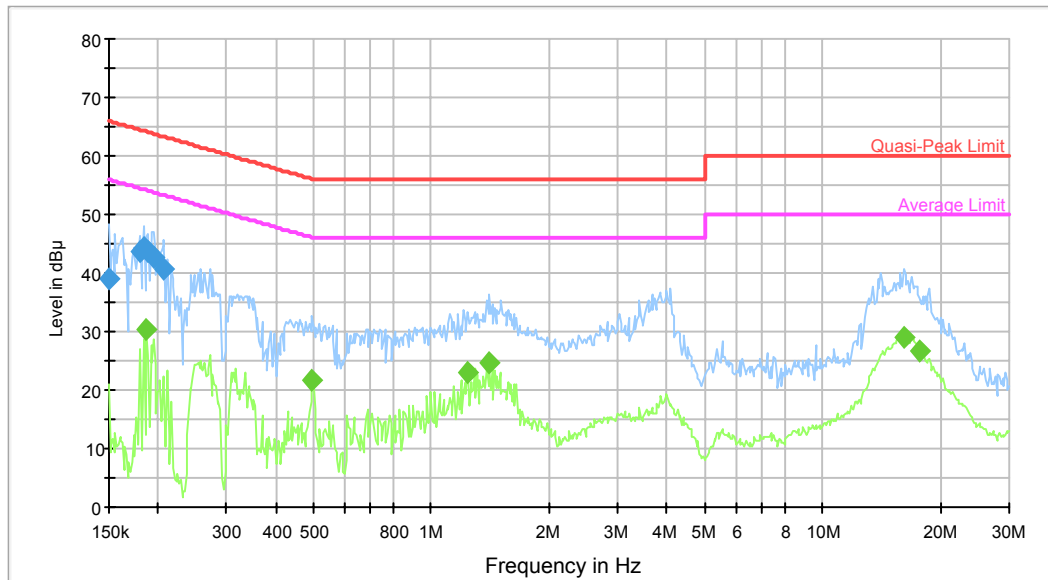

Frequency (MHz)	QuasiPeak (dBµV)	Bandwidth (kHz)	Line	Corr. (dB)	Margin (dB)	Limit (dBµV)	Comment
0.150000	39.0	9.000	L1	10.2	27.0	66.0	Compliance
0.180171	43.6	9.000	L1	10.2	20.9	64.5	Compliance
0.184529	44.3	9.000	L1	10.2	20.0	64.3	Compliance
0.188994	43.5	9.000	L1	10.2	20.6	64.1	Compliance
0.195114	42.8	9.000	L1	10.2	21.0	63.8	Compliance
0.207957	40.8	9.000	L1	10.2	22.5	63.3	Compliance

Frequency (MHz)	Average (dBµV)	Bandwidth (kHz)	Line	Corr. (dB)	Margin (dB)	Limit (dBµV)	Comment
0.187494	30.3	9.000	L1	10.2	23.8	54.1	Compliance
0.495646	21.8	9.000	L1	10.1	24.3	46.1	Compliance
1.239175	23.2	9.000	L1	10.4	22.8	46.0	Compliance
1.407671	24.5	9.000	L1	10.4	21.5	46.0	Compliance
16.122185	29.0	9.000	L1	10.7	21.0	50.0	Compliance
17.739864	26.7	9.000	L1	10.8	23.3	50.0	Compliance

**AC120V, 60Hz, Neutral:**

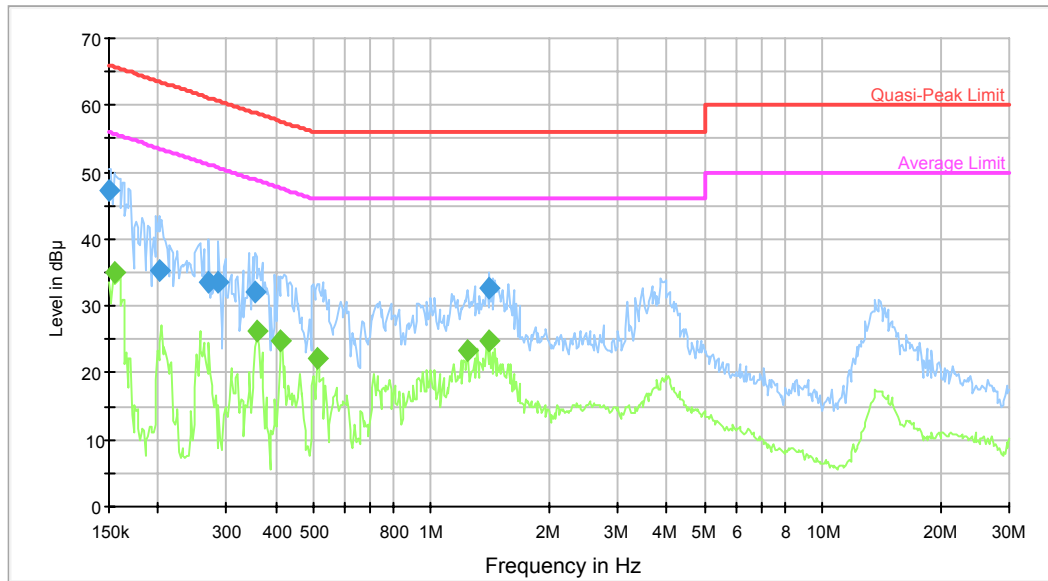

Frequency (MHz)	QuasiPeak (dBµV)	Bandwidth (kHz)	Line	Corr. (dB)	Margin (dB)	Limit (dBµV)	Comment
0.150000	47.2	9.000	N	10.2	18.8	66.0	Compliance
0.201433	35.2	9.000	N	10.2	28.4	63.6	Compliance
0.270502	33.6	9.000	N	10.2	27.5	61.1	Compliance
0.286019	33.4	9.000	N	10.2	27.2	60.6	Compliance
0.354674	32.0	9.000	N	10.3	26.9	58.9	Compliance
1.407671	32.6	9.000	N	10.4	23.4	56.0	Compliance

Frequency (MHz)	Average (dBµV)	Bandwidth (kHz)	Line	Corr. (dB)	Margin (dB)	Limit (dBµV)	Comment
0.154858	35.0	9.000	N	10.2	20.7	55.7	Compliance
0.360371	26.3	9.000	N	10.3	22.4	48.7	Compliance
0.412647	24.8	9.000	N	10.2	22.8	47.6	Compliance
0.511698	22.1	9.000	N	10.1	23.9	46.0	Compliance
1.239175	23.2	9.000	N	10.4	22.8	46.0	Compliance
1.407671	24.7	9.000	N	10.4	21.3	46.0	Compliance

**Adapter 1&Battery 2**

**AC120V, 60Hz, Line:**

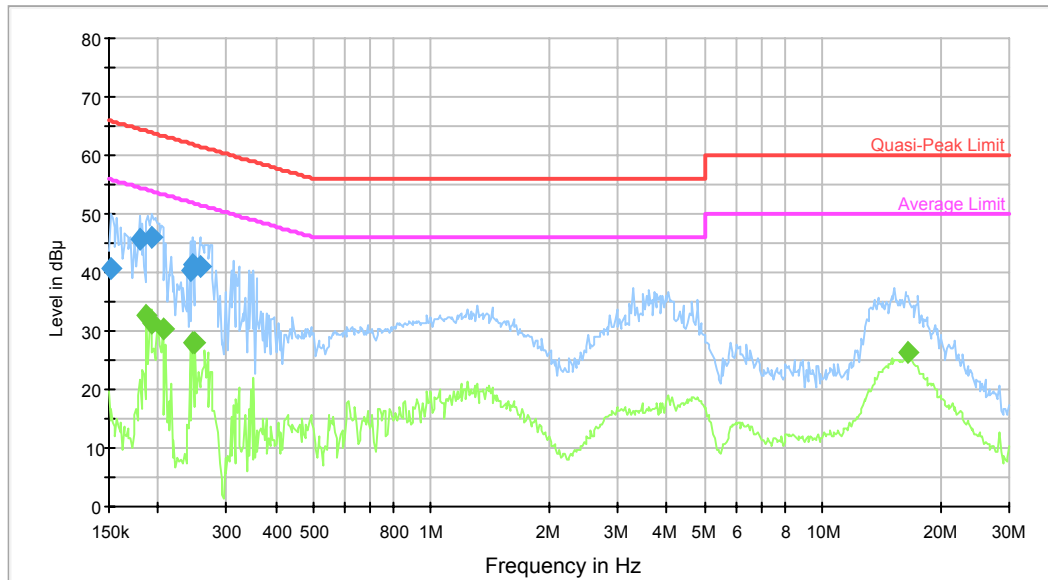

Frequency (MHz)	QuasiPeak (dBµV)	Bandwidth (kHz)	Line	Corr. (dB)	Margin (dB)	Limit (dBµV)	Comment
0.152410	40.7	9.000	L1	10.2	25.2	65.9	Compliance
0.180171	45.6	9.000	L1	10.2	18.9	64.5	Compliance
0.193566	45.9	9.000	L1	10.2	18.0	63.9	Compliance
0.241949	40.4	9.000	L1	10.2	21.6	62.0	Compliance
0.245835	41.3	9.000	L1	10.2	20.6	61.9	Compliance
0.255827	40.9	9.000	L1	10.2	20.7	61.6	Compliance

Frequency (MHz)	Average (dBµV)	Bandwidth (kHz)	Line	Corr. (dB)	Margin (dB)	Limit (dBµV)	Comment
0.187494	32.7	9.000	L1	10.2	21.4	54.1	Compliance
0.192030	31.3	9.000	L1	10.2	22.6	53.9	Compliance
0.206306	30.4	9.000	L1	10.2	23.0	53.4	Compliance
0.245835	28.1	9.000	L1	10.2	23.8	51.9	Compliance
0.249785	27.9	9.000	L1	10.2	23.9	51.8	Compliance
16.512221	26.2	9.000	L1	10.7	23.8	50.0	Compliance

**AC120V, 60Hz, Neutral:**

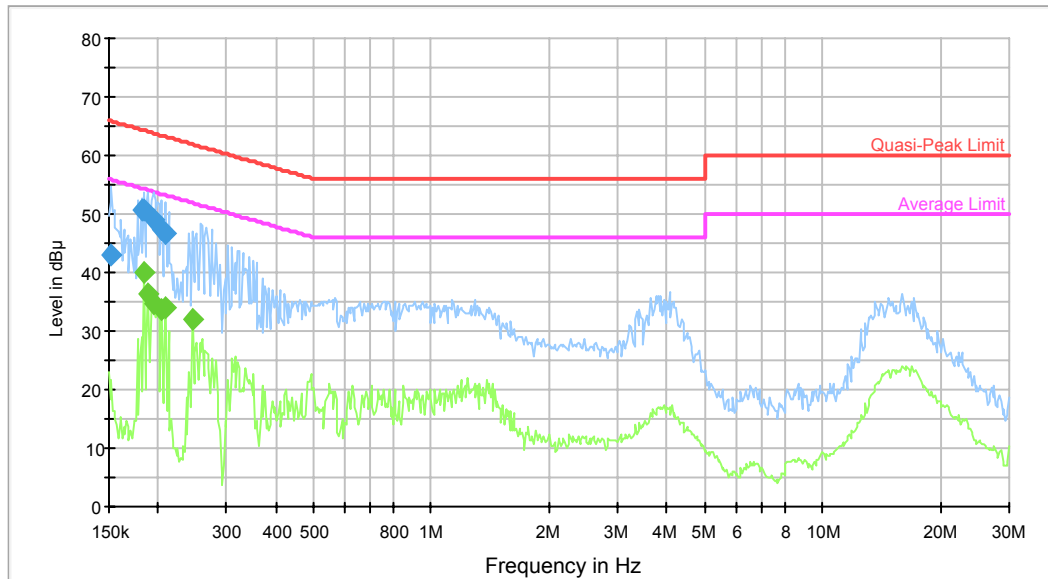

Frequency (MHz)	QuasiPeak (dBµV)	Bandwidth (kHz)	Line	Corr. (dB)	Margin (dB)	Limit (dBµV)	Comment
0.152410	43.0	9.000	N	10.2	22.9	65.9	Compliance
0.181612	50.6	9.000	N	10.1	13.8	64.4	Compliance
0.184529	50.6	9.000	N	10.1	13.7	64.3	Compliance
0.195114	49.0	9.000	N	10.2	14.8	63.8	Compliance
0.204669	47.4	9.000	N	10.2	16.0	63.4	Compliance
0.209621	46.6	9.000	N	10.2	16.6	63.2	Compliance

Frequency (MHz)	Average (dBµV)	Bandwidth (kHz)	Line	Corr. (dB)	Margin (dB)	Limit (dBµV)	Comment
0.184529	39.8	9.000	N	10.1	14.5	54.3	Compliance
0.188994	36.2	9.000	N	10.2	17.9	54.1	Compliance
0.195114	34.7	9.000	N	10.2	19.1	53.8	Compliance
0.204669	33.5	9.000	N	10.2	19.9	53.4	Compliance
0.209621	34.0	9.000	N	10.2	19.2	53.2	Compliance
0.245835	31.9	9.000	N	10.2	20.0	51.9	Compliance



**Adapter 2&Battery 1**

**AC120V, 60Hz, Line:**

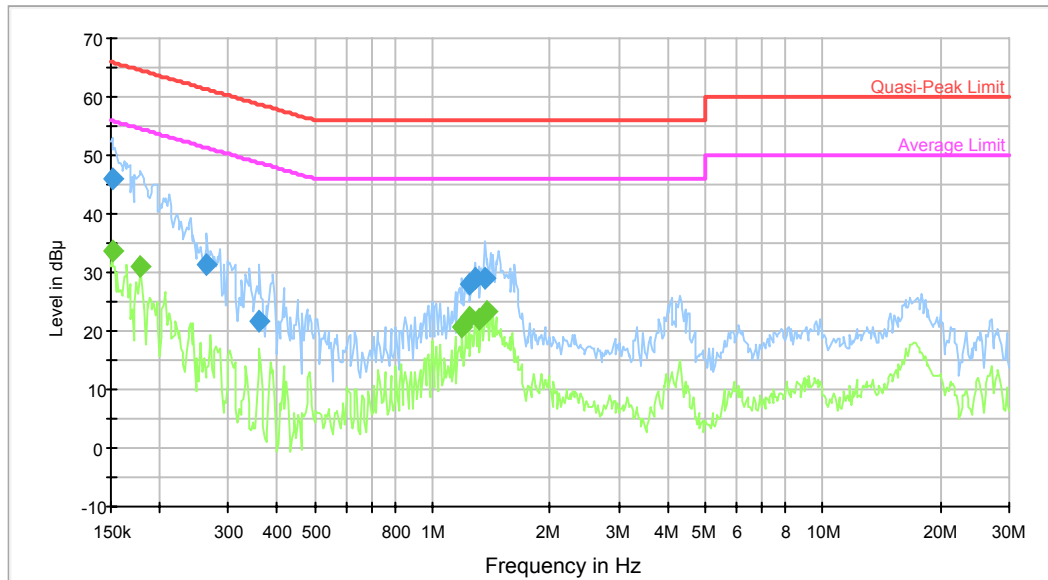

Frequency (MHz)	QuasiPeak (dBµV)	Bandwidth (kHz)	Line	Corr. (dB)	Margin (dB)	Limit (dBµV)	Comment
0.151200	46.0	9.000	L1	10.2	19.9	65.9	Compliance
0.264113	31.5	9.000	L1	10.2	29.8	61.3	Compliance
0.360371	21.8	9.000	L1	10.3	36.9	58.7	Compliance
1.239175	27.9	9.000	L1	10.4	28.1	56.0	Compliance
1.289541	29.0	9.000	L1	10.4	27.0	56.0	Compliance
1.363512	29.1	9.000	L1	10.4	26.9	56.0	Compliance

Frequency (MHz)	Average (dBµV)	Bandwidth (kHz)	Line	Corr. (dB)	Margin (dB)	Limit (dBµV)	Comment
0.151200	33.8	9.000	L1	10.2	22.1	55.9	Compliance
0.178741	30.8	9.000	L1	10.1	23.7	54.5	Compliance
1.190776	20.7	9.000	L1	10.4	25.3	46.0	Compliance
1.239175	22.5	9.000	L1	10.4	23.5	46.0	Compliance
1.310256	21.9	9.000	L1	10.4	24.1	46.0	Compliance
1.385415	23.3	9.000	L1	10.4	22.7	46.0	Compliance

**AC120V, 60Hz, Neutral:**

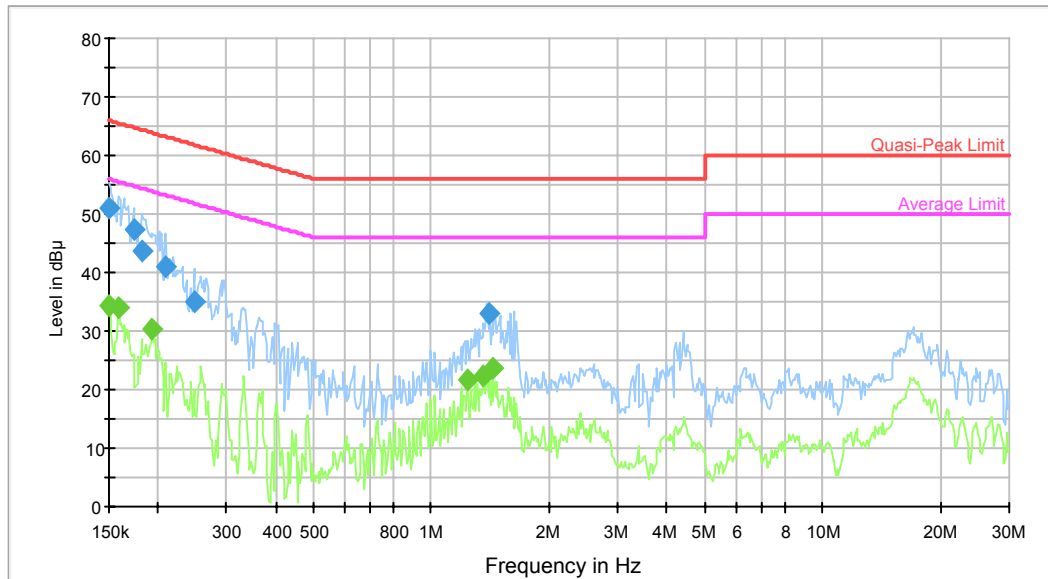

Frequency (MHz)	QuasiPeak (dBµV)	Bandwidth (kHz)	Line	Corr. (dB)	Margin (dB)	Limit (dBµV)	Comment
0.150000	51.0	9.000	N	10.2	15.0	66.0	Compliance
0.173134	47.2	9.000	N	10.1	17.6	64.8	Compliance
0.181612	43.5	9.000	N	10.1	20.9	64.4	Compliance
0.209621	40.9	9.000	N	10.2	22.3	63.2	Compliance
0.247802	35.0	9.000	N	10.2	26.8	61.8	Compliance
1.407671	32.9	9.000	N	10.4	23.1	56.0	Compliance

Frequency (MHz)	Average (dBµV)	Bandwidth (kHz)	Line	Corr. (dB)	Margin (dB)	Limit (dBµV)	Comment
0.150000	34.4	9.000	N	10.2	21.6	56.0	Compliance
0.158604	34.0	9.000	N	10.1	21.5	55.5	Compliance
0.193566	30.5	9.000	N	10.2	23.4	53.9	Compliance
1.239175	21.8	9.000	N	10.4	24.2	46.0	Compliance
1.363512	22.2	9.000	N	10.4	23.8	46.0	Compliance
1.430284	23.6	9.000	N	10.4	22.4	46.0	Compliance

**Adapter 2&Battery 2**

**AC120V, 60Hz, Line:**

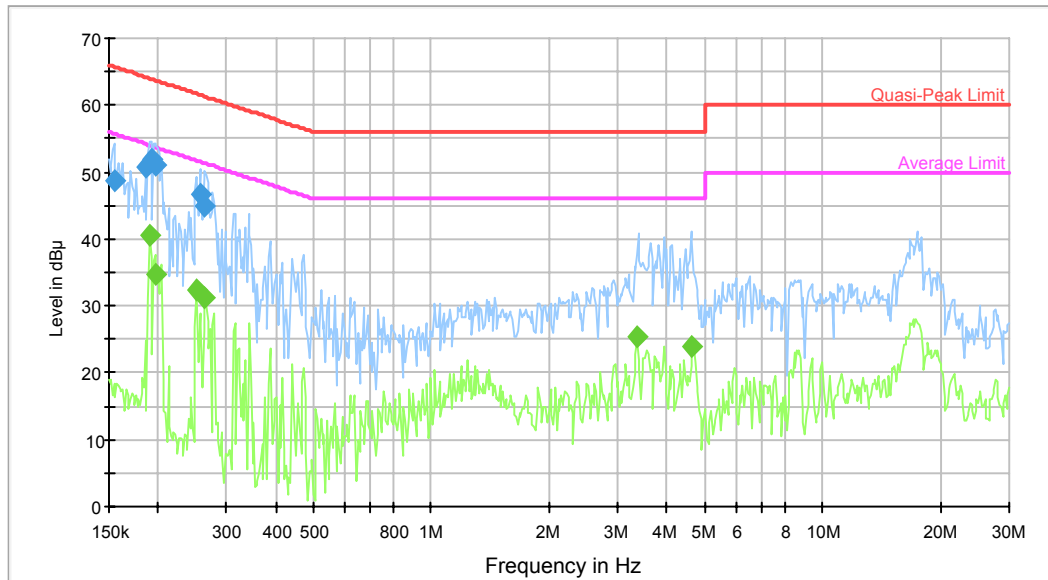

Frequency (MHz)	QuasiPeak (dBµV)	Bandwidth (kHz)	Line	Corr. (dB)	Margin (dB)	Limit (dBµV)	Comment
0.154858	48.6	9.000	L1	10.2	17.1	65.7	Compliance
0.186006	50.8	9.000	L1	10.2	13.4	64.2	Compliance
0.192030	52.0	9.000	L1	10.2	12.0	64.0	Compliance
0.196675	51.0	9.000	L1	10.2	12.7	63.7	Compliance
0.255827	46.8	9.000	L1	10.2	14.8	61.6	Compliance
0.264113	44.9	9.000	L1	10.2	16.4	61.3	Compliance

Frequency (MHz)	Average (dBµV)	Bandwidth (kHz)	Line	Corr. (dB)	Margin (dB)	Limit (dBµV)	Comment
0.190505	40.6	9.000	L1	10.2	13.4	54.0	Compliance
0.196675	34.7	9.000	L1	10.2	19.0	53.7	Compliance
0.251783	32.5	9.000	L1	10.2	19.2	51.7	Compliance
0.264113	31.3	9.000	L1	10.2	20.0	51.3	Compliance
3.355051	25.3	9.000	L1	10.6	20.7	46.0	Compliance
4.651370	23.9	9.000	L1	10.7	22.1	46.0	Compliance

**AC120V, 60Hz, Neutral:**

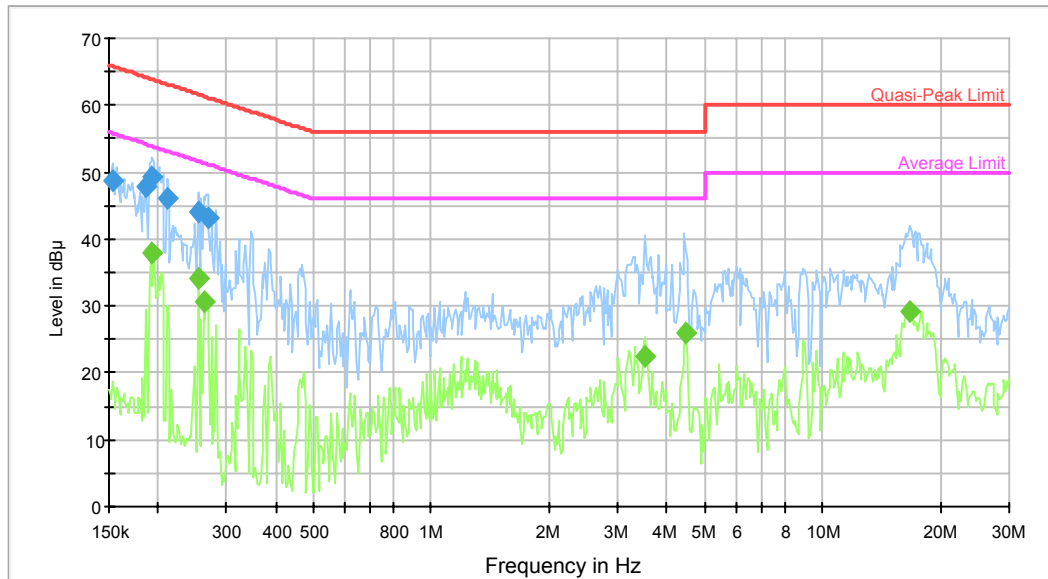

Frequency (MHz)	QuasiPeak (dBµV)	Bandwidth (kHz)	Line	Corr. (dB)	Margin (dB)	Limit (dBµV)	Comment
0.153629	48.6	9.000	N	10.2	17.2	65.8	Compliance
0.186006	47.8	9.000	N	10.2	16.4	64.2	Compliance
0.193566	49.4	9.000	N	10.2	14.5	63.9	Compliance
0.211298	46.0	9.000	N	10.2	17.2	63.2	Compliance
0.253797	43.9	9.000	N	10.2	17.7	61.6	Compliance
0.268355	43.3	9.000	N	10.2	17.9	61.2	Compliance

Frequency (MHz)	Average (dBµV)	Bandwidth (kHz)	Line	Corr. (dB)	Margin (dB)	Limit (dBµV)	Comment
0.192030	37.8	9.000	N	10.2	16.1	53.9	Compliance
0.253797	34.2	9.000	N	10.2	17.4	51.6	Compliance
0.262017	30.6	9.000	N	10.2	20.8	51.4	Compliance
3.519348	22.6	9.000	N	10.6	23.4	46.0	Compliance
4.469698	26.0	9.000	N	10.7	20.0	46.0	Compliance
16.777473	29.0	9.000	N	10.7	21.0	50.0	Compliance

## FCC §15.109 - RADIATED EMISSIONS

### Measurement Uncertainty

Compliance or non-compliance with a disturbance limit shall be determined in the following manner:

If  $U_{lab}$  is less than or equal to  $U_{cispr}$  of Table 2, then:

- compliance is deemed to occur if no measured disturbance level exceeds the disturbance limit;
- non-compliance is deemed to occur if any measured disturbance level exceeds the disturbance limit.

If  $U_{lab}$  is greater than  $U_{cispr}$  of Table 1, then:

- compliance is deemed to occur if no measured disturbance level, increased by  $(U_{lab} - U_{cispr})$ , exceeds the disturbance limit;
- non-compliance is deemed to occur if any measured disturbance level, increased by  $(U_{lab} - U_{cispr})$ , exceeds the disturbance limit.

Based on CISPR 16-4-2: 2011, measurement uncertainty of radiated emission at a distance of 3m at Bay Area Compliance Laboratories Corp. (Dongguan) is: 30M~200MHz: 4.58 dB for Horizontal, 4.59 dB for Vertical; 200M~1GHz: 4.83 dB for Horizontal, 5.85 dB for Vertical; 1G~6GHz: 4.45 dB, 6G~18GHz: 5.23 dB.

Table 1 – Values of  $U_{cispr}$

Measurement	$U_{cispr}$
Radiated disturbance (electric field strength at an OATS or in a SAC) (30 MHz to 1000 MHz)	6.3 dB
Radiated disturbance (electric field strength in a FAR) (1 GHz to 6 GHz)	5.2 dB
Radiated disturbance (electric field strength in a FAR) (6 GHz to 18 GHz)	5.5 dB

### EUT Setup

Below 1 GHz:

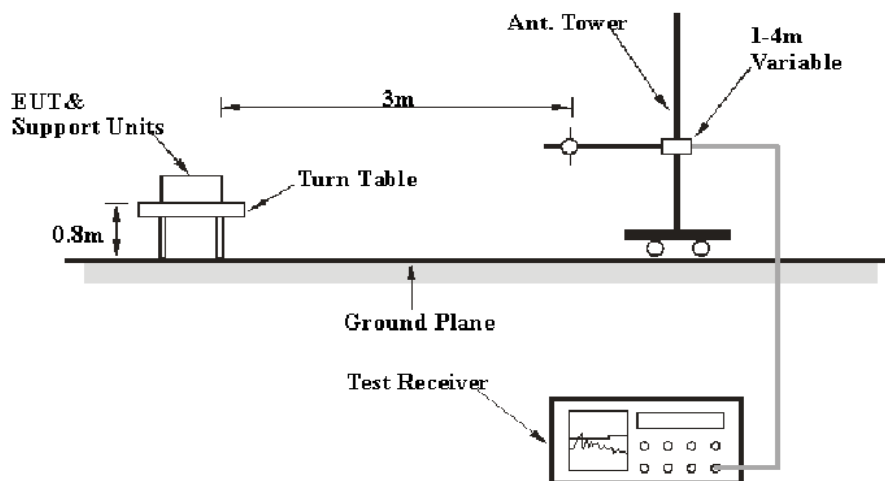

Above 1GHz:

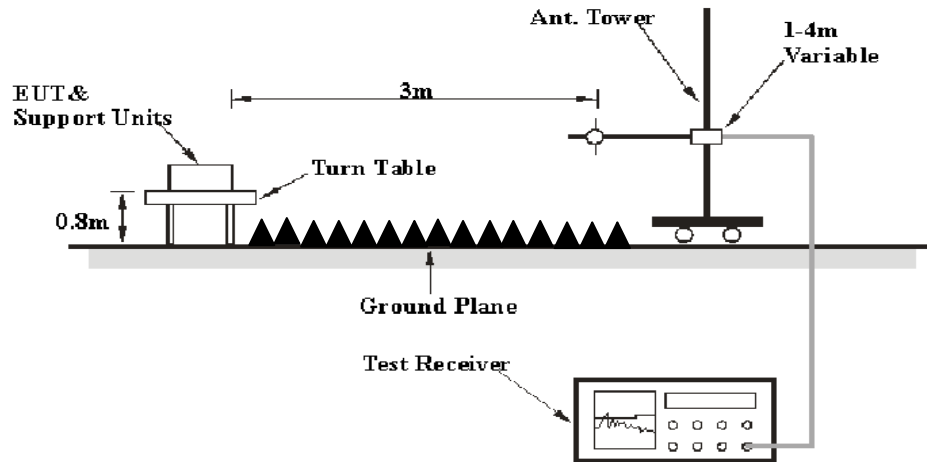

The radiated emission tests were performed in the 3 meters chamber test site, using the setup accordance with the ANSI C63.4-2014. The specification used was the FCC Part 15.109, Class B limits.

The external I/O cables were draped along the test table and formed a bundle 30 to 40 cm long in the middle.

The spacing between the peripherals was 10 cm.

**EMI Test Receiver Setup**

According to FCC 15.33 requirements, the system was measured from 30 MHz to 30 GHz.

During the radiated emission test, the EMI test receiver was set with the following configurations:

Frequency Range	RBW	Video B/W	IF B/W	Detector
30 MHz – 1000 MHz	120 kHz	300 kHz	120 kHz	QP
Above 1GHz	1MHz	3 MHz	/	Peak
	1MHz	10 Hz	/	Ave.

**Test Procedure**

Maximizing procedure was performed on the highest emissions to ensure that the EUT complied with all installation combinations.

The data was recorded in Quasi-peak detection mode for 30 MHz to 1 GHz, Peak and average detection mode above 1 GHz.

## Corrected Amplitude & Margin Calculation

The Corrected Amplitude is calculated by adding the Antenna Loss and Cable Loss, and subtracting the Amplifier Gain from the Meter Reading. The basic equation is as follows:

$$\text{Corrected Amplitude} = \text{Meter Reading} + \text{Antenna Loss} + \text{Cable Loss} - \text{Amplifier Gain}$$

The “**Margin**” column of the following data tables indicates the degree of compliance with the applicable limit. For example, a margin of 7dB means the emission is 7dB below the limit. The equation for margin calculation is as follows:

$$\text{Margin} = \text{Limit} - \text{Corrected Amplitude}$$

## Test Equipment List and Details

Manufacturer	Description	Model	Serial Number	Calibration Date	Calibration Due Date
R&S	EMI Test Receiver	ESCI	100224	2016-08-03	2017-08-02
Sunol Sciences	Antenna	JB3	A060611-3	2014-07-28	2017-07-27
HP	Amplifier	8447E	2434A02181	2015-09-01	2016-09-01
Agilent	Spectrum Analyzer	E4440A	SG43360054	2015-11-23	2016-11-22
N/A	Coaxial Cable	14m	N/A	2016-05-06	2017-05-06
N/A	Coaxial Cable	8m	N/A	2016-05-06	2017-05-06
Sinoscite	Bandstop Filters	BSF5150-5850MN-0899-003	N/A	2016-05-06	2017-05-06
ETS-Lindgren	Horn Antenna	3115	9808-5557	2015-09-06	2018-09-06
Mini-Circuit	Amplifier	ZVA-213-S+	054201245	2016-02-19	2017-02-19
Agilent	Spectrum Analyzer	8564E	3943A01781	2016-05-08	2017-05-08
Ducommun Technologies	Horn Antenna	ARH-4223-02	1007726-01 1304	2014-06-16	2017-06-15
Ducommun Technologies	Horn Antenna	ARH-2823-02	1007726-01 1302	2014-06-16	2017-06-15
Quinstar	Amplifier	QLW-18405536-JO	15964001001	2015-09-06	2016-09-06

\* **Statement of Traceability:** Bay Area Compliance Laboratories Corp. (Dongguan) attests that all calibrations have been performed, traceable to National Primary Standards and International System of Units (SI).

## Test Data

### Environmental Conditions

<b>Temperature:</b>	25.3 °C
<b>Relative Humidity:</b>	65 %
<b>ATM Pressure:</b>	98.9kPa

*The testing was performed by Kira Liu on 2016-08-18.*

*Refer to the following data.*

1) Test mode: Downloading

**Below 1GHz:**

**Horizontal:**

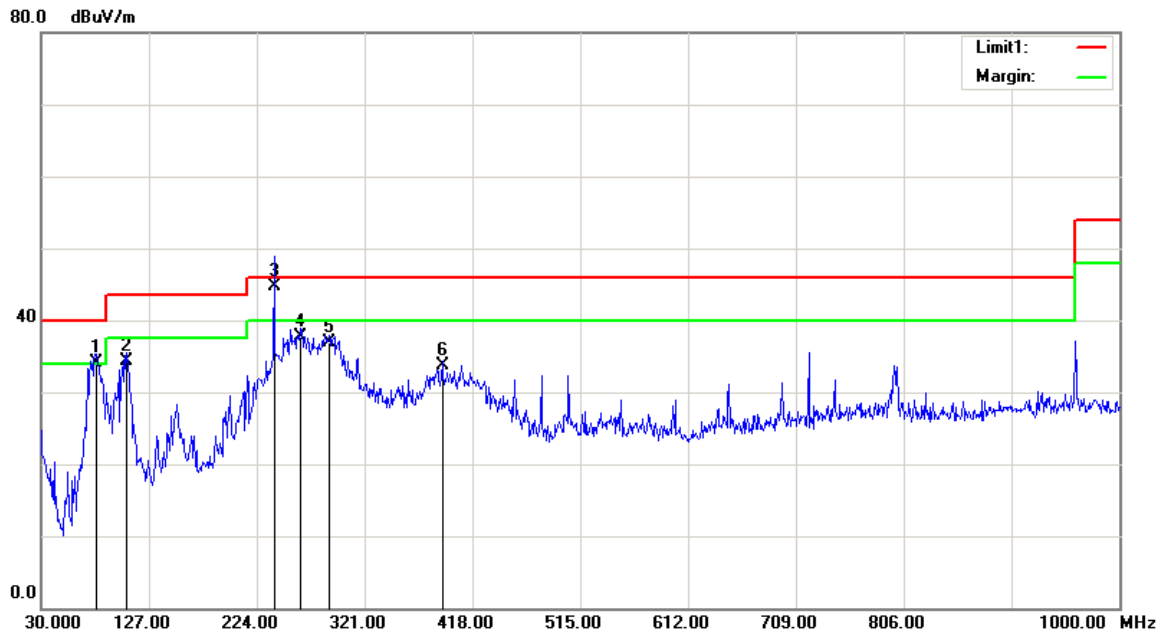

Frequency (MHz)	Receiver Reading (dBuV)	Detector (PK/QP/Ave)	Correction Factor (dB/m)	Cord. Amp. (dBuV/m)	Limit (dBuV/m)	Margin (dB)
79.4700	46.22	QP	-12.02	34.20	40.00	5.80
106.6300	42.20	QP	-7.90	34.30	43.50	9.20
239.5200	52.30	QP	-7.60	44.70	46.00	1.30
263.7700	44.28	QP	-6.48	37.80	46.00	8.20
288.9900	42.75	QP	-5.85	36.90	46.00	9.10
390.8400	37.63	QP	-3.93	33.70	46.00	12.30



**Vertical:**

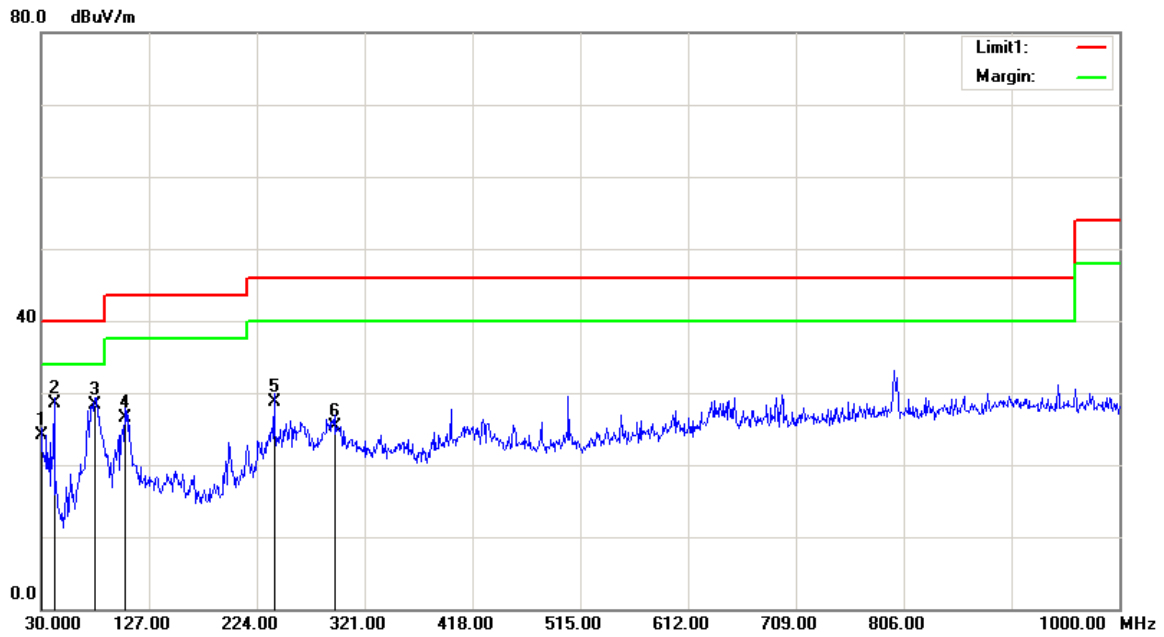

Frequency (MHz)	Receiver Reading (dBuV)	Detector (PK/QP/Ave)	Correction Factor (dB/m)	Cord. Amp. (dBuV/m)	Limit (dBuV/m)	Margin (dB)
30.0000	23.25	QP	0.95	24.20	40.00	15.80
41.6400	36.25	QP	-7.65	28.60	40.00	11.40
78.5000	40.40	QP	-12.00	28.40	40.00	11.60
105.6600	34.61	QP	-8.11	26.50	43.50	17.00
239.5200	36.30	QP	-7.60	28.70	46.00	17.30
293.8400	31.11	QP	-5.81	25.30	46.00	20.70

**Above 1GHz:**

**Horizontal:**

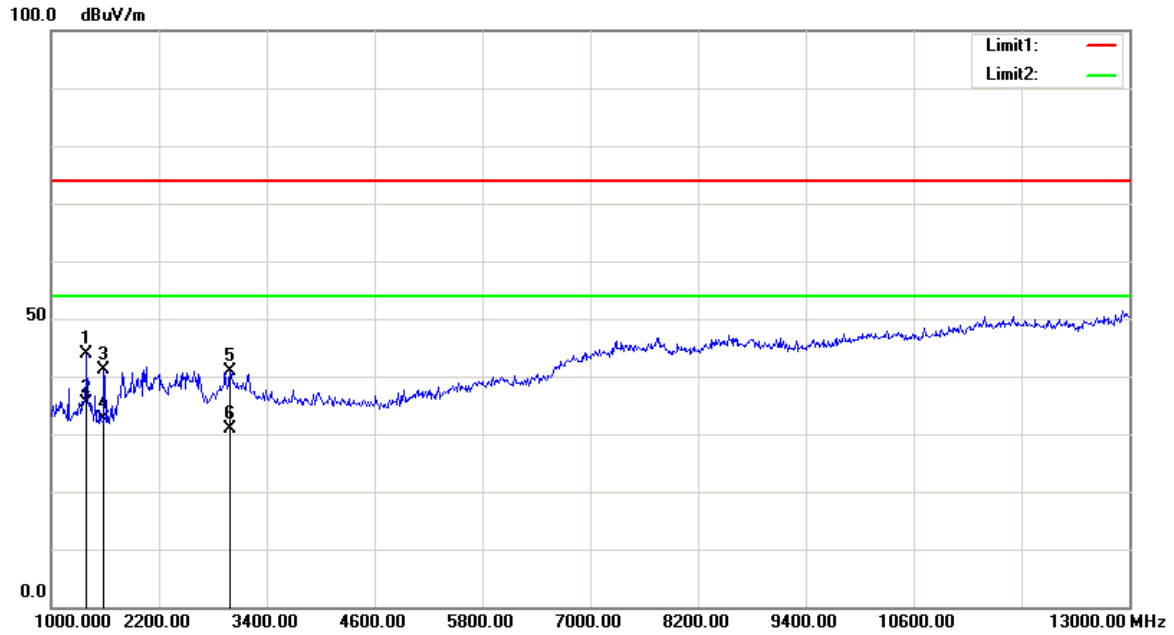

Frequency (MHz)	Receiver Reading (dBuV)	Detector (PK/QP/Ave)	Correction Factor (dB/m)	Cord. Amp. (dBuV/m)	Limit (dBuV/m)	Margin (dB)
1396.000	44.77	peak	-0.88	43.89	74.00	30.11
1396.000	36.16	AVG	-0.88	35.28	54.00	18.72
1594.000	41.94	peak	-0.79	41.15	74.00	32.85
1594.000	33.30	AVG	-0.79	32.51	54.00	21.49
2998.000	34.27	peak	6.64	40.91	74.00	33.09
2998.000	24.34	AVG	6.64	30.98	54.00	23.02

Note: no emission was detected in the range 13-30GHz

**Vertical:**

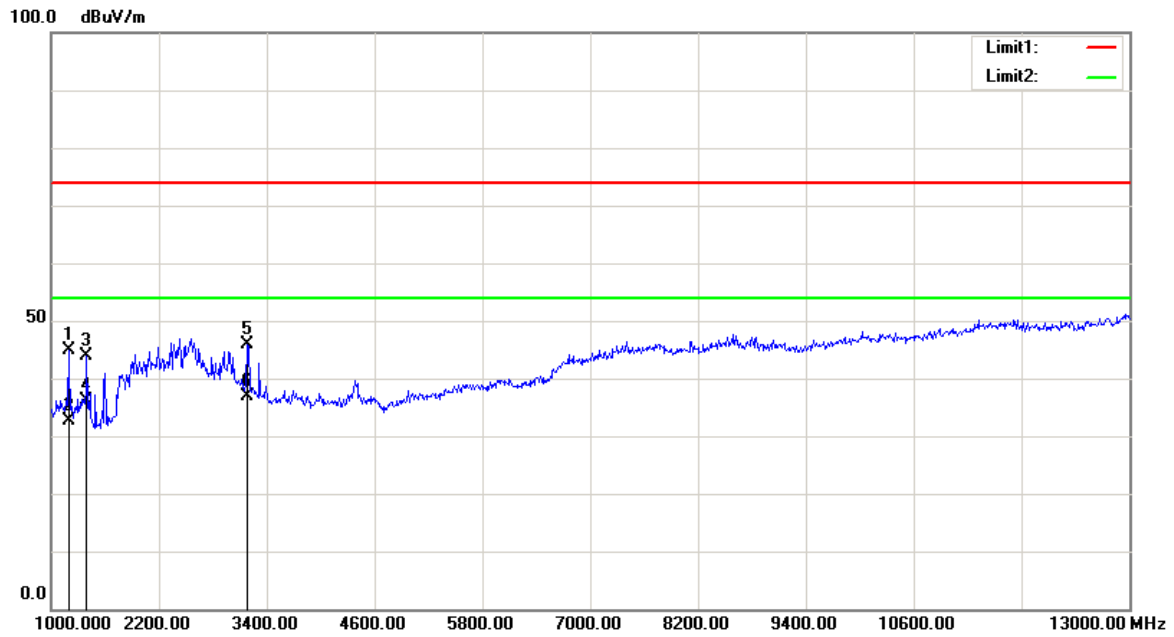

Frequency (MHz)	Receiver Reading (dBuV)	Detector (PK/QP/Ave)	Correction Factor (dB/m)	Cord. Amp. (dBuV/m)	Limit (dBuV/m)	Margin (dB)
1198.000	46.27	peak	-1.42	44.85	74.00	29.15
1198.000	34.01	AVG	-1.42	32.59	54.00	21.41
1396.000	44.82	peak	-0.88	43.94	74.00	30.06
1396.000	37.09	AVG	-0.88	36.21	54.00	17.79
3190.000	39.18	peak	6.66	45.84	74.00	28.16
3190.000	30.23	AVG	6.66	36.89	54.00	17.11

Note: no emission was detected in the range 13-30GHz.

2) Test mode: Charging (pretest each adapter and battery, the worst mode for each adapter as below)

Adapter 1 & Battery 1

**Below 1GHz:**

**Horizontal:**

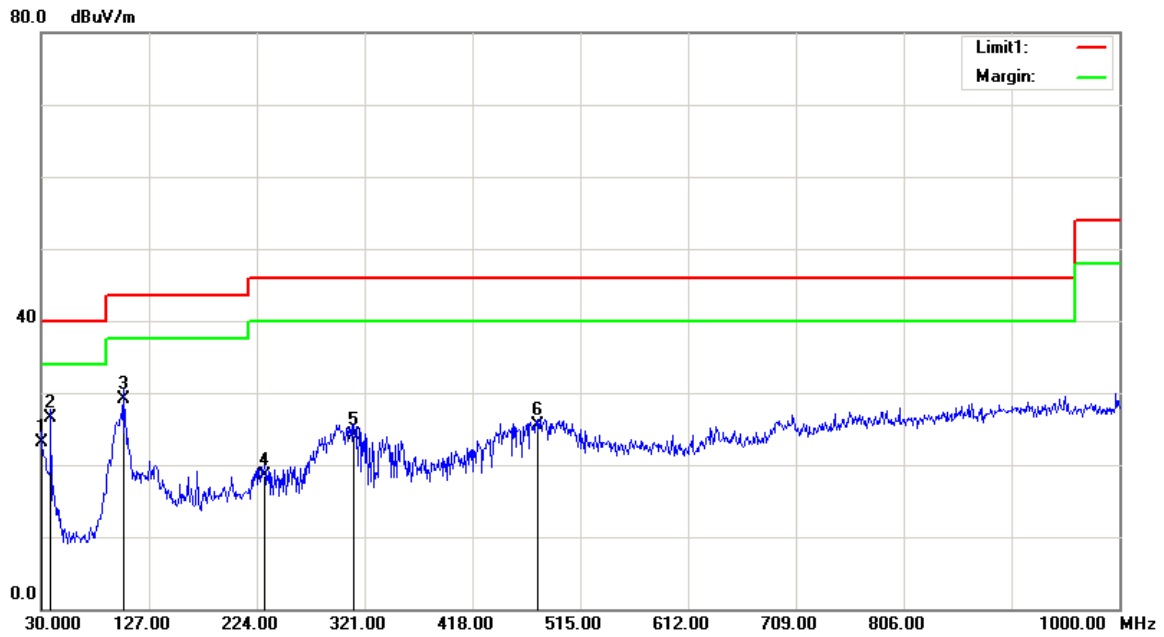

Frequency (MHz)	Receiver Reading (dBuV)	Detector (PK/QP/Ave)	Correction Factor (dB/m)	Cord. Amp. (dBuV/m)	Limit (dBuV/m)	Margin (dB)
30.0000	22.15	QP	0.95	23.10	40.00	16.90
38.7300	32.11	QP	-5.61	26.50	40.00	13.50
103.7200	37.70	QP	-8.60	29.10	43.50	14.40
230.7900	26.67	QP	-8.07	18.60	46.00	27.40
311.3000	29.78	QP	-5.58	24.20	46.00	21.80
476.2000	27.25	QP	-1.75	25.50	46.00	20.50

**Vertical:**

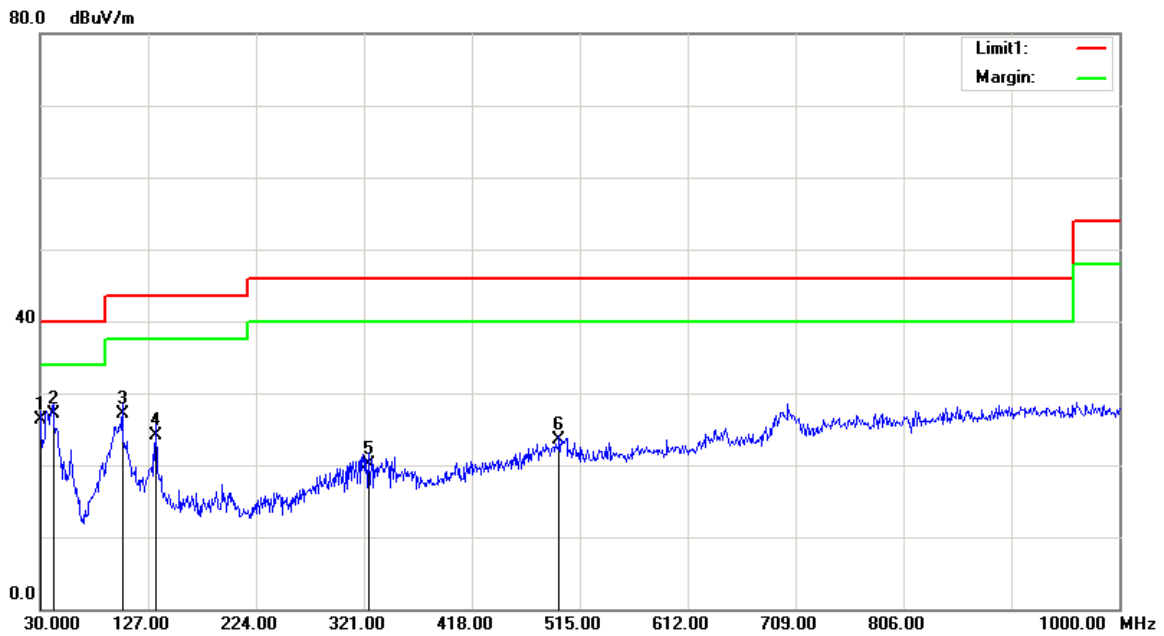

Frequency (MHz)	Receiver Reading (dBuV)	Detector (PK/QP/Ave)	Correction Factor (dB/m)	Cord. Amp. (dBuV/m)	Limit (dBuV/m)	Margin (dB)
30.0000	25.35	QP	0.95	26.30	40.00	13.70
41.6400	34.85	QP	-7.65	27.20	40.00	12.80
103.7200	35.70	QP	-8.60	27.10	43.50	16.40
133.7900	30.15	QP	-5.95	24.20	43.50	19.30
324.8800	25.49	QP	-5.39	20.10	46.00	25.90
496.5700	24.94	QP	-1.44	23.50	46.00	22.50

Adapter2& Battery 2

Horizontal:

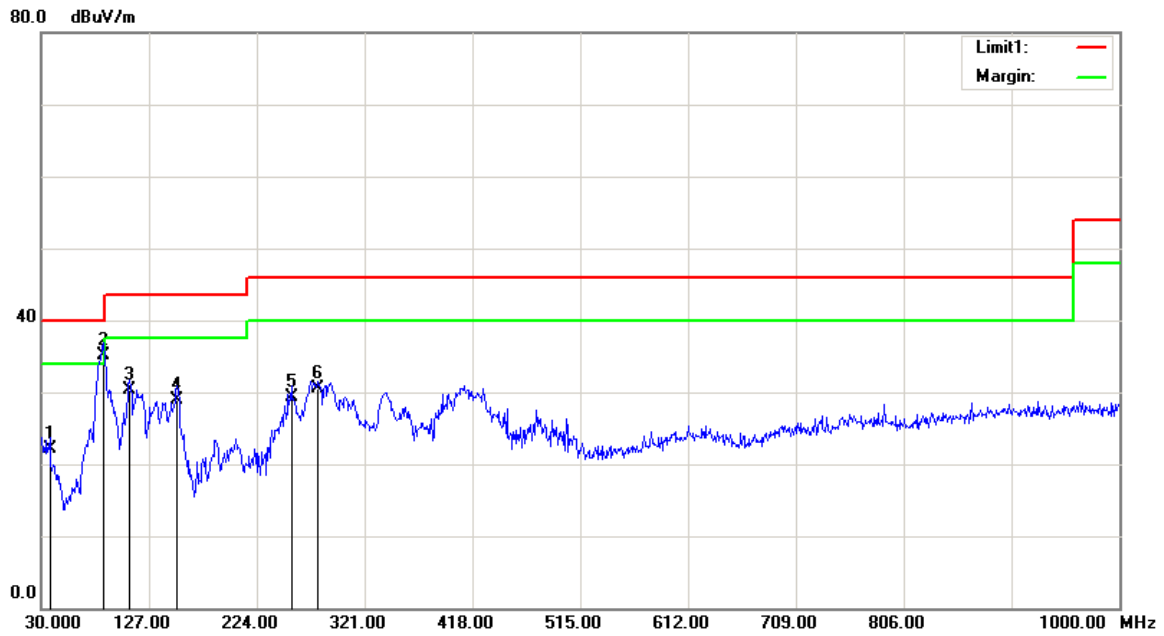

Frequency (MHz)	Receiver Reading (dBuV)	Detector (PK/QP/Ave)	Correction Factor (dB/m)	Cord. Amp. (dBuV/m)	Limit (dBuV/m)	Margin (dB)
37.7600	26.98	QP	-4.88	22.10	40.00	17.90
86.2600	47.40	QP	-12.20	35.20	40.00	4.80
109.5400	37.62	QP	-7.32	30.30	43.50	13.20
152.2200	36.02	QP	-7.12	28.90	43.50	14.60
255.0400	37.08	QP	-7.68	29.40	46.00	16.60
279.2900	36.46	QP	-5.96	30.50	46.00	15.50

**Vertical:**

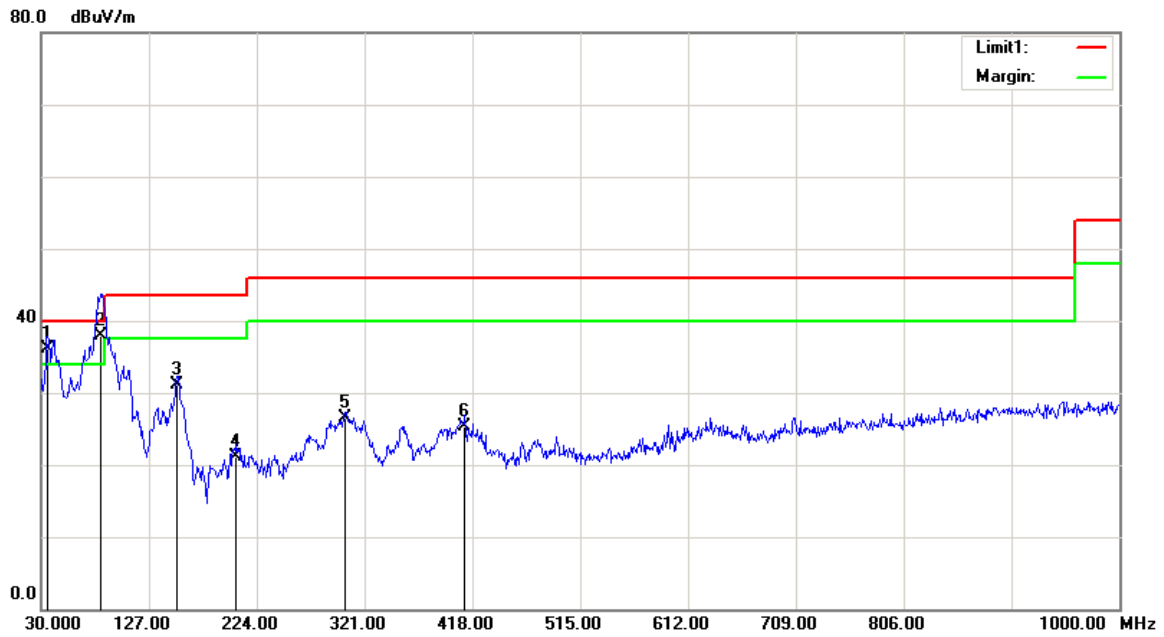

Frequency (MHz)	Receiver Reading (dBuV)	Detector (PK/QP/Ave)	Correction Factor (dB/m)	Cord. Amp. (dBuV/m)	Limit (dBuV/m)	Margin (dB)
35.8200	39.36	QP	-3.26	36.10	40.00	3.90
83.3500	50.05	QP	-12.15	37.90	40.00	2.10
152.2200	38.22	QP	-7.12	31.10	43.50	12.40
205.5700	29.59	QP	-8.39	21.20	43.50	22.30
303.5400	32.20	QP	-5.70	26.50	46.00	19.50
411.2100	28.78	QP	-3.38	25.40	46.00	20.60

**\*\*\*\*\*END OF REPORT\*\*\*\*\***